

Convotherm mini

compact creativity



Combi Oven
Convotherm mini

OES mini 6.06, 6.10, 10.10
Installation Manual UL, USA - Original, ENG

Advancing Your Ambitions

FOR THE INSTALLER, OPERATOR, RESPONSIBLE OWNER

FOR YOUR SAFETY
Do not store or use gasoline or other flammable vapors or liquids in the vicinity of this or any other unit.

	WARNING
	Improper installation, adjustment, alteration, service or maintenance can cause property damage, injury and death. Read the installation, operating and maintenance instructions thoroughly before installing or servicing this equipment.

	<p>WARNING</p> <p>To reduce the risk of electric shock, do not remove or open cover. No user serviceable parts inside. Refer servicing to qualified personnel. Disconnect power supply before servicing.</p> <p>AVERTISSEMENT</p> <p>Afin de réduire le risque d'électrocution, ne pas retirer ou ouvrir le capot. Aucune pièce réparable ne se trouve à l'intérieur. Confier le dépannage à du personnel qualifié. Débrancher l'alimentation électrique avant réparation.</p>
-------------------------------------------------------------------------------------	----------------------------------------------------------------------------------------------------------------------------------------------------------------------------------------------------------------------------------------------------------------------------------------------------------------------------------------------------------------------------------------------------------------------------------------------------------------------------------------------

	WARNING
	Disconnect power at the main external power switch before servicing or repairing a combi oven.

IMPORTANT

ALL SERVICE MUST BE PERFORMED BY A QUALIFIED CONVOTHERM AUTHORIZED TECHNICIAN.

KEEP AREA FREE AND CLEAR OF COMBUSTIBLES.

Installation

- Installation of this unit must be done by a licensed professional when installed in the Commonwealth of Massachusetts.
- The wiring diagram is located on the inner part of the side panel.

Customer documentation

- The customer documentation is part of the combi oven.
- Keep the customer documentation manuals handy at all times so that you can look up any required information.
- Keep the customer documentation manuals for the entire life of the unit.
- Carefully read the installation manual, the operating manual, and the operating instructions before using, handling, and working on this unit.
- If you transfer the combi oven to a new owner, make sure to give the new owner the customer documentation manuals as well.

Table of Contents

1	General	7
1.1	Environmental Protection	7
1.2	Identifying Your Combi Oven	8
1.3	Customer Documentation Structure	9
1.4	About This Installation Manual	9
1.5	Safety Information That Must Be Read without Exception	10
2	Configuration and Functions	11
2.1	The Combi Oven's Configuration and Functions	11
2.2	Control Panel Layout and Functions	13
3	For Your Safety	14
3.1	Basic Safety Instructions	14
3.2	Your Combi Oven's Intended Use	16
3.3	Warning Labels on the Combi Oven	18
3.4	Obligations of Owners and Personnel with the Authority to Issue Instructions in the Kitchen Area	20
3.5	Hazards posed by the unit	21
3.6	Safety Devices	23
3.7	Staff and Work Area Requirements	25
3.8	Personal protective equipment	27
4	Transportation	28
4.1	Transporting the unit to the installation location	28
4.2	Preparing for Unpacking	28
4.3	Included equipment and parts	29
5	Setup	30
5.1	Adjacent Systems	30
5.2	Installation location requirements	31
5.3	Removing the unit from the pallet (10.10 mini)	35
5.4	Setting up the unit on a work table	36
5.5	Setting Up the Unit on a Stand	37
5.6	Setting Up Units in a Stacking Kit	39
6	Installation	40
6.1	Electrical installation	40
6.1.1	Planning the Electrical Installation	40
6.1.2	Performing the Electrical Installation	42
6.2	Network Connection	43
6.2.1	Planning the Network Connection	43
6.3	Making the Network Connection	44
6.4	Water connection	45
6.4.1	Water supply	45
6.4.2	Checking the water quality	48
6.4.3	Drain connection	49
6.5	Installing the ConvoClean System (for Units with ConvoClean / ConvoClean+)	51
6.5.1	Components of Fully Automatic Oven Cleaning System	51
6.5.2	Connecting the Fully Automatic Cleaning System	52

7	Placing into operation	53
7.1	Working Safely When Putting the Unit Into Operation	53
7.2	Procedure for Placing the Unit into Operation	54
8	Removing from Service and Disposal	56
8.1	Removing from Service and Disposal	56
9	Technical data	57
9.1	Dimensions and weights	57
9.2	Maximum permissible loading weight	58
9.3	Electrical supply	59
9.4	Heat loss	62
9.5	Water connections	62
9.6	Water quality	63
9.7	Water consumption	63
10	Connection drawings	64
10.1	Dimensions and Connection Points (Standard)	64
10.2	Dimensions and Connection Points (easyTouch)	68

1 General

1.1 Environmental Protection

Policy statement

Our customers' expectations, the legal regulations and standards we have to follow, and our company's reputation are what drives the quality and service behind all our products.

Our environmental management policy is not only designed to ensure that we are always in full compliance with all environmental laws and regulations, but also reflects our commitment to the environment and to continuously improving our performance in this field.

In order to ensure that we meet all of our environmental goals while maintaining the high quality of our products, and that things stay this way, we have developed a quality and environmental management system.

This system meets the requirements set forth in ISO 9001:2015 and ISO 14001:2015.

Environmental protection measures

The following measures apply to this product:

- Uses fully compostable packing products
- Uses RoHS-compliant products
- Complies with the REACH regulation
- Shipping boxes are reused
- Recommends and uses biodegradable cleaning agents
- E-waste recycling
- Environmentally friendly disposal of old units

Join us in our commitment to protecting the environment!

1.2 Identifying Your Combi Oven

Nameplate location

The nameplate is found on the left side of the combi oven.

Nameplate layout and structure

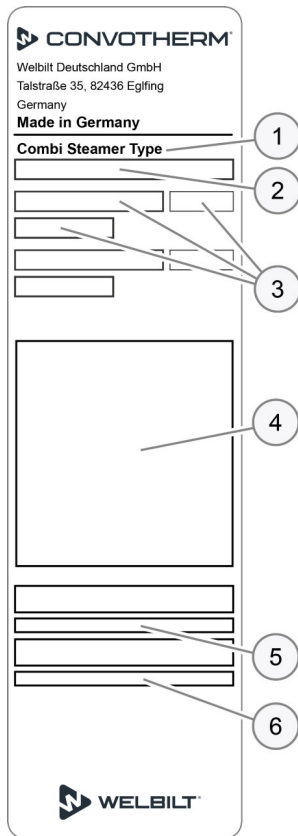

No.	Designation	
1	Unit name Combi Steamer	
2	Trade name Letters OES xx.yy numbers mini	Meaning Electrical units with water injection Unit size Series
3	Electrical specifications	
4	Unit tests	
5	Serial number	
6	Item number	

1.3 Customer Documentation Structure

Unit documentation parts

Document type	Contents
Installation manual	<ul style="list-style-type: none"> ▪ Describes how to transport, set up, install, and put the unit into operation ▪ Goes over all the hazards involved in the various installation activities and how to prevent and/or counter them ▪ Contains technical specifications
Operating manual	<ul style="list-style-type: none"> ▪ Describes the work sequences and operating steps when cooking and cleaning ▪ Includes the maintenance schedule and troubleshooting information ▪ Goes over all the hazards involved when operating the unit and how to prevent and/or counter them
Operating instructions	<ul style="list-style-type: none"> ▪ Describes the unit's user interface ▪ Includes the instructions for using the software

Documentation for accessories

For information on how to install accessories (e.g., recoil hand shower, hood, stand on casters, stacking kit), please refer to the corresponding instructions for accessories.

1.4 About This Installation Manual

Target groups for this installation manual

Name of target group	Tasks
Combi oven owner or the owner's employee who is responsible for the unit and for the staff operating it	<ul style="list-style-type: none"> ▪ Briefed on all of the combi oven's safety-relevant functions, mechanisms, and devices by the person placing the unit into operation ▪ Shown how the unit is operated by the person placing the unit into operation ▪ If necessary, helping out as directed with transportation within the facilities and with setting up the unit <p>For more detailed information, please refer to 'Obligations of Combi Oven Owner' on page 20</p>
Mover	Transporting the unit within the facilities
Service technician	<ul style="list-style-type: none"> ▪ Setting up the unit ▪ Installing the fully automatic oven cleaning system ▪ Placing the unit into operation and removing it from service
Electrician	<ul style="list-style-type: none"> ▪ Connecting the unit to the electrical connection at the facilities ▪ Uninstalling electrical connections
Water and wastewater installer	<ul style="list-style-type: none"> ▪ Connecting the unit to the water connection at the facilities ▪ Uninstalling water connections ▪ Connecting the unit to the drain connection at the facilities ▪ Uninstalling the drain connection
Person placing the unit into operation (service technician)	<ul style="list-style-type: none"> ▪ Responsible overall for placing the combi oven into operation ▪ Briefing the user

Decimal mark used

In order to ensure that all numbers can be properly understood internationally, a decimal point is always used.

1.5 Safety Information That Must Be Read without Exception

Safety information found in the documentation for the customer

Only the installation manual and operating manual provide safety information for the combi oven.

The installation manual provides safety information for the transportation, setup, installation, placing-into-operation, and removal-from-service tasks it describes.

The operating manual provides safety information for the cooking, cleaning, and maintenance tasks it describes.

When using the operating instructions, the operating manual or installation manual should always be consulted in order to obtain the relevant safety information. When performing activities that go beyond simply using the software, the safety information in the operating manual and installation manual must always be observed.

Parts of this document that must be read without exception

Failure to take the information in this document into account may result in death, injury, or property damage.

In order to ensure their safety and the safety of others, everyone working with/on the combi oven must read and understand the following parts of this document before starting any work:

- The 'For Your Safety on page 14' section
- The sections describing the work that will be carried out



Danger symbol

Danger symbol	Meaning
	Used to warn of potential injury. Observe all the precautionary statements following this symbol in order to avoid injury or death.



Precautionary statements

The precautionary statements in this manual are categorized using the following hazard levels:

Hazard level	Consequences	Likelihood
 DANGER	Death / severe injury (irreversible)	Imminent
 WARNING	Death / severe injury (irreversible)	Potential
 CAUTION	Minor injury (reversible)	Potential
NOTICE	Property damage	Potential

2 Configuration and Functions

2.1 The Combi Oven's Configuration and Functions

Parts and functions

The figure below shows a size 6.10 mini combi oven used as an example representing all models:

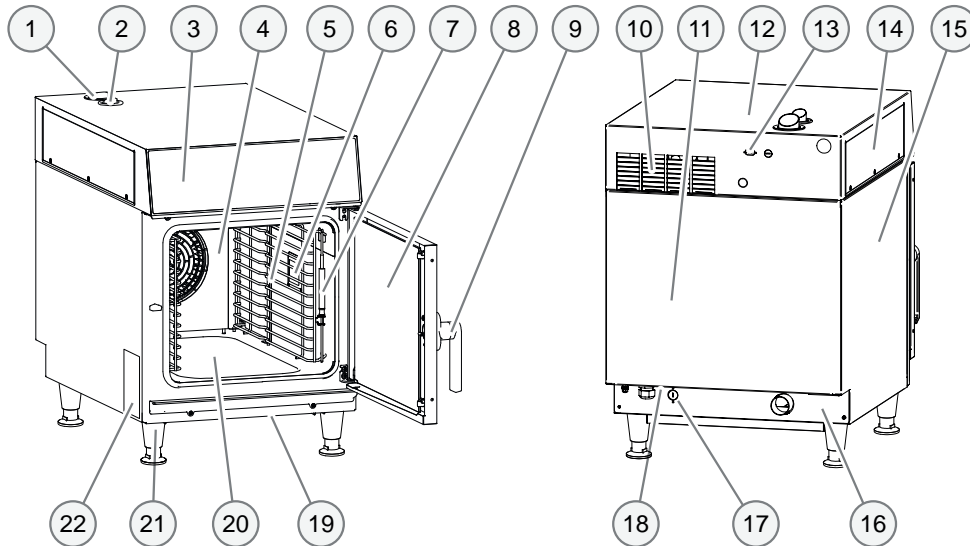

No.	Designation	Function
1	Ventilation port	Draws in ambient air in order to remove moisture from the oven cavity
2	Air vent	Lets hot steam escape
3	Control panel	Used to operate the unit
4	Suction panel	Used to distribute heat uniformly within the oven cavity
5	Rack	Used to hold standard-size bakeware
6	Oven light	Illuminates the oven cavity
7	Core temperature probe (optional)	Used to measure the food's core temperature
8	Unit door	Seals the oven cavity
9	Door handle	<ul style="list-style-type: none"> ▪ Used to open and close the unit door ▪ Cracked-open position for safely opening the unit ("safety lock")
10	Vents	Used for ventilation purposes
11	Rear panel	Covers the unit's wiring compartment
12	Top enclosure	Covers the unit's control electronics
13	Condensation hood connection (optional with easyTouch)	Used to connect a Halton condensation hood
14	Cover on top enclosure	Used to access the electronics in the top enclosure
15	Outer case	Used to cover the inside of the unit
16	Connection angle bracket	Used to cover the connection area
17	Condensation hood connection (optional)	Used to connect a mini Condensation Hood Pro
18	Network connection	Used to connect to a network
19	Openings in base	Used for ventilation purposes
20	Oven cavity	Is where food is placed while it is being cooked

2 Configuration and Functions

No.	Designation	Function
21	Unit feet	Used to set up and level the unit
22	Nameplate	Used to identify the unit

Material

The unit's inner and outer parts are made of stainless steel.

2.2 Control Panel Layout and Functions

Control panel layout and parts (standard)

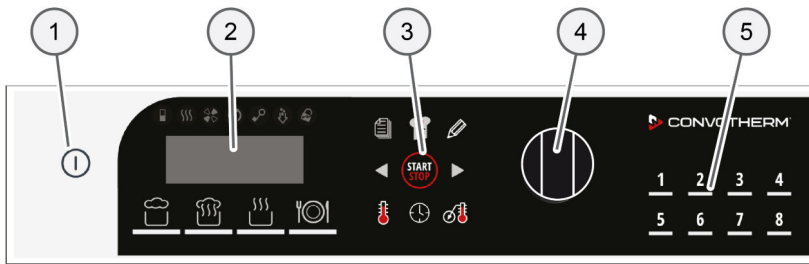

No.	Designation	Function
1	Unit ON/OFF switch	Used to turn the combi oven on and off
2	Display and program selection	<ul style="list-style-type: none"> Shows the active cooking program and the selected extra functions Used to select a basic cooking program or rethermalization program
3	Data input	<ul style="list-style-type: none"> Used to select a cooking parameter so that it can be configured Starts and stops the cooking program
4	Knob	Cooking parameters and extra functions can be selected or adjusted by turning this knob
5	Press&Go buttons	Programmable quick-select buttons

Control panel layout and parts (easyTouch)

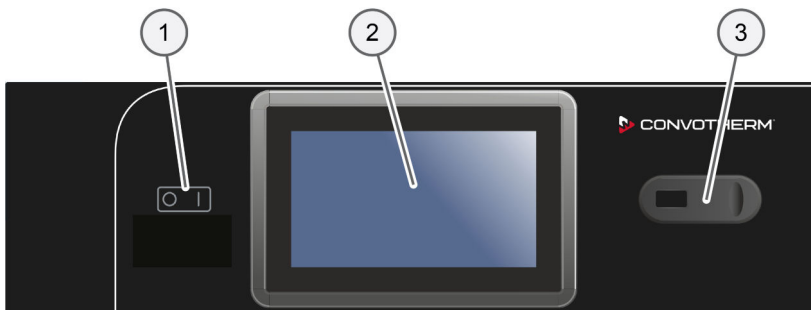

No.	Designation	Function
1	Unit ON/OFF switch	Used to turn the combi oven on and off
2	Full-touch display	The unit's central control interface <ul style="list-style-type: none"> Used by touching the icons on the full-touch display Status indicators
3	USB port	Used to plug in a USB stick

3 For Your Safety

Purpose of this section

The purpose of this section is to provide you with all the information you will need in order to safely work with/on the combi oven without putting yourself and others at risk.

Read this section very carefully!

3.1 Basic Safety Instructions

Purpose of these instructions

The purpose of these instructions is to ensure that everyone working with and on the combi oven will be fully aware of all the risks, hazards, and safety requirements involved and will observe the warnings in the operating manual and on the combi oven. Failure to follow these instructions may result in death, injury, or property damage.

Customer documentation manuals

Follow the instructions below:

- Fully read the 'For Your Safety' section, as well as the section that applies to the way you will be interacting with the combi oven.
- Keep the customer documentation manuals handy at all times so that you can look up any required information.
- If you transfer the combi oven to a new owner, make sure to give the new owner the customer documentation manuals as well.

Basic rules for installation

The unit must be installed in compliance with all national and state laws and regulations, with all applicable local requirements and regulations set forth by the relevant local utility companies and authorities, and with all other relevant regulations and standards.

These include, but are not limited to:

- The National Electrical Code, ANSI/NFPA 70 (current edition)
- The Canadian Electrical Code, CSA C22.2
- The Food Code and Food Service Sanitation Manual published by the Food and Drug Administration (FDA) (current editions)
- Latest edition of the International Plumbing Code published by the International Code Council (ICC) or the Uniform Plumbing Code published by the International Association of Plumbing and Mechanical Officials (IAPMO)
- The standards published by the National Sanitation Foundation (NSF)
- All local fire protection and occupational health and safety regulations

Working with/on the combi oven

Follow the instructions below:

- Only people who meet all the requirements specified in this operating manual should be allowed to use and otherwise work with/on the combi oven.
- Only use the combi oven for its intended use as described in this manual. Never, under any circumstance, use the combi oven for other purposes, even if they seem obvious.
- Observe all the safety measures specified in this operating manual and on the combi oven. This applies especially to wearing the required personal protective equipment.
- Make sure to always stay in the specified work areas when working with/on the combi oven.
- Do not make any alterations to the combi oven. This includes removing components and adding components that have not been expressly approved. Above all, however, make sure not to disable any safety devices or guards.

For more information...

Related subjects

▷ Your Combi Oven's Intended Use	16
▷ Warning Labels on the Combi Oven	18
▷ Hazards posed by the unit	21
▷ Safety Devices	23
▷ Staff and Work Area Requirements	25
▷ Personal protective equipment	27

3.2 Your Combi Oven's Intended Use

The combi oven's intended use

- The combi oven has been designed and built exclusively for cooking a variety of food in standard-size food containers (steam table pans, sheet pans, etc.). Steam, convection, and combi-steam (steam superheated without pressure) are used for this purpose.
- The food containers can be made of stainless steel, ceramic, plastic, aluminum, enameled steel, or glass. Glass food containers must not be damaged.
- The combi oven is intended exclusively for professional commercial use.

Limitations on use

The combi oven should not be used to heat up the following materials:

- Dry powders or granular products
- Readily flammable substances or objects with a flashpoint lower than 518 °F, such as readily flammable oils, fats, plastics, cleaning agents, and liquids containing alcohol.
- Food in sealed cans

Staff requirements

- The combi oven must be run and installed exclusively by staff meeting the specified requirements. For the corresponding training and qualifications requirements, please refer to 'Staff and Work Area Requirements on page 25.'
- All staff must be familiar with the risks, hazards, and rules involved in handling heavy loads.

Requirements concerning the combi oven's functional capability

- Do not operate the combi oven unless it has been properly transported, set up, installed, and placed into operation as indicated in the installation manual and the person responsible for placing it into operation has confirmed this.
- The combi oven should only be used if all safety devices and guards are present, working properly, and correctly locked in place.
- All manufacturer specifications concerning how to run and service the combi oven must be observed.
- The load placed inside the combi oven must never exceed the maximum permissible loading weight; please refer to 'Technical Data' on page 57.

Requirements concerning the combi oven's surroundings

Required combi oven surroundings

- Ambient temperature between 40°F and 95°F
- No toxic or potentially explosive atmospheres
- Do not use or store gasoline or other flammable vapors, gases, or liquids in the vicinity of a combi oven
- Dry kitchen floor in order to reduce the risk of accidents occurring

Required installation location characteristics

- NO fire alarms or sprinkler system directly above the unit
- NO flammable materials, gases, or liquids above, on, under, or close to the unit

Limitations on use

- When used outdoors, the unit must be protected from rain and wind
- Do NOT shift or move the unit during operation

Prerequisites for cleaning

- Only use the cleaning agents approved by the manufacturer.
- Only use the cleaning tools specified by the manufacturer; please refer to 'Cleaning schedule' in the operating manual.
- Do NOT use a pressure washer to clean the unit.
- Do NOT use a water jet to clean the outside of the unit. Do not use an external water jet for anything other than cleaning the oven cavity.
- Do NOT use bases or acids to clean the combi oven and make sure it is not exposed to acid fumes. The only exception is when the oven cavity is descaled by an authorized service company following the manufacturer's instructions.

3.3 Warning Labels on the Combi Oven

Warning label location

The figure below shows a size 6.10 mini combi oven used as an example representing all models:

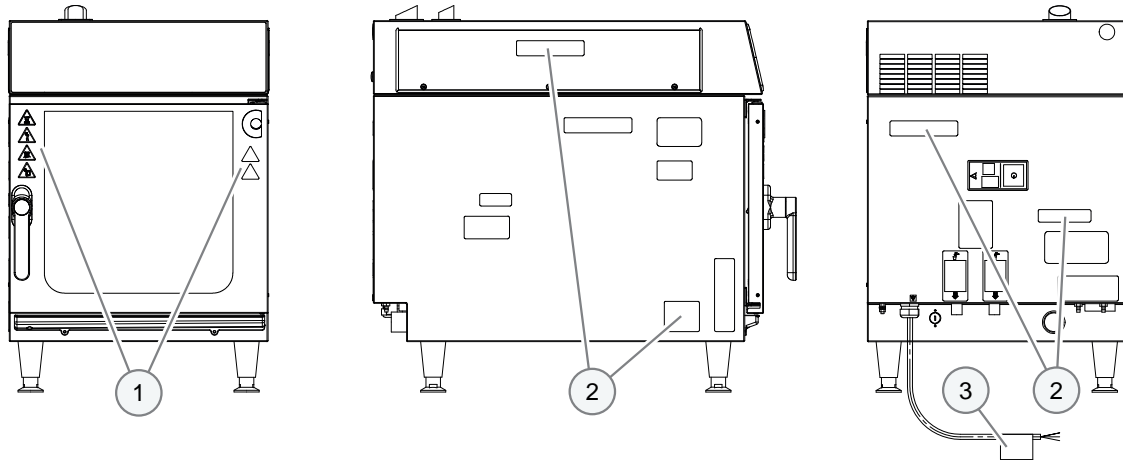





Warning labels on unit door

Warning labels (1) on the unit door:

Warning	Description
	<p>Hot surface warning A burn hazard is posed by hot surfaces on the unit door, inside the entire oven, and by all parts that are inside the oven during cooking.</p>
	<p>Hot food, hot bakeware, and hot liquid warning Hot food and hot bakeware will pose a burn hazard if the bakeware falls off the shelf levels or if food slides off bakeware that is being held in an inclined position. This hazard will be particularly acute in the case of shelf levels located above the operator's field of view. Risk of scalding when liquid food is spilled. This hazard exists when liquids, or food that becomes liquefied during cooking, are placed on the upper shelf levels. Do not use shelf levels located above your field of view for liquids or food that will become liquefied.</p>
	<p>With ConvoClean / ConvoClean+ option only Caustic cleaning agent warning Skin, eye, and respiratory tract irritation hazard posed as a result of contact with cleaning agents, as well as their vapors, if the unit door is opened during fully automatic cleaning (ConvoClean system).</p>
	<p>Hot steam warning There is a risk of scalding posed by the hot steam coming out when the unit door is opened.</p>
	<p>Combi oven tip-over hazard warning There is a risk of the combi oven toppling over when being moved. Exercise extreme caution when moving the combi oven.</p>
	<p>Unit hookup damage and disconnection warning There is a risk of the unit's hookups being damaged or disconnected when the combi oven is moved. Exercise extreme caution when moving the combi oven and take the connections' length into account.</p>

Warning labels on combi oven case

Warning labels (2) on combi oven case:

Warning	Description
	<p>WARNING</p> <p>To reduce the risk of electric shock, do not remove or open cover. No user serviceable parts inside. Refer servicing to qualified personnel. Disconnect power supply before servicing.</p>
	<p>AVERTISSEMENT</p> <p>Afin de réduire le risque d'électrocution, ne pas retirer ou ouvrir le capot. Aucune pièce réparable ne se trouve à l'intérieur. Confier le dépannage à du personnel qualifié. Débrancher l'alimentation électrique avant réparation.</p>
	<p>CAUTION</p> <p>Before commencing plumbing installation refer to installation instruction furnished with unit.</p> <p>DO NOT INSTALL a SHUTOFF ON DRAIN OUTLET</p>
	<p>WARNING</p> <p>Cancer and Reproductive Harm www.p65Warnings.ca.gov</p>
	<p>AVERTISSEMENT</p> <p>Cancer et Troubles de l'appareil reproducteur www.p65Warnings.ca.gov</p>

Warnings in the combi oven wiring compartment

Warnings in the combi oven wiring compartment:

Warning	Description
	<p>WARNING</p> <p>Field conversion from 3 PH to 1 PH is not permitted.</p>

Warning labels on power cord

Warning labels (3) on the power cord:

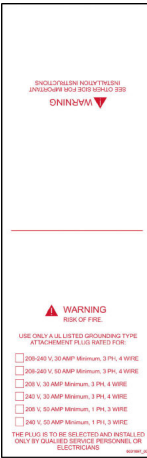
Warning	Description
	<p>WARNING</p> <p>Risk of Fire. Use only a UL listed grounding type attachment plug rated for:</p> <ul style="list-style-type: none"> 208-240 V, 30 AMP Minimum, 3 PH, 4 Wire 208-240 V, 50 AMP Minimum, 3 PH, 4 Wire 208 V, 30 AMP Minimum, 3 PH, 4 Wire 240 V, 30 AMP Minimum, 3 PH, 4 Wire 208 V, 50 AMP Minimum, 1 PH, 3 Wire 240 V, 50 AMP Minimum, 1 PH, 3 Wire <p>The plug is to be selected and installed only by qualified service personnel or electricians.</p>

3.4 Obligations of Owners and Personnel with the Authority to Issue Instructions in the Kitchen Area

Personnel working on the combi oven

The store manager or person with the authority to issue instructions must make sure that all transportation, setup, installation, and removal-from-service work is carried out exclusively by qualified personnel as described in 'Staff and Work Area Requirements.' on page 25

Personnel working on electrical systems

The store manager or person with the authority to issue instructions must make sure that all assembly, placement-into-operation, servicing, maintenance, and repair work is carried out exclusively by qualified electricians.

Electrical assembly, placement-into-operation, servicing, maintenance, repair, and testing work on the combi ovens must be carried out exclusively by authorized service companies in conformity with the placement-into-operation, servicing, maintenance, and repair documents specified by Convotherm.

The required activities must be carried out exclusively by qualified electricians who have the required training and current professional experience and who have the necessary familiarity with all applicable standards, regulations, and accident prevention regulations.

Every qualified electrician performing assembly, placement-into-operation, servicing, maintenance, or repair work must have read and understood the installation manual.

Rules for working on electrical systems

The combi oven must be electrically connected in conformity with all applicable regulations and generally accepted standards and practices, as well as with the procedure outlined in the installation manual.

It is necessary to ensure that all electrical precautions, guards, and devices (mechanical and electrical) are being adhered to and are effective every time before the unit is put into operation, as well as after any servicing, maintenance, or repair work. Moreover, this must be verified and documented by means of measurements if required by applicable regulations.

Before being worked on, the unit must always be de-energized and locked and tagged out. In addition, it is necessary to double-check that it has actually been de-energized properly.

After it has been established that the unit is properly de-energized, it is necessary to wait at least 15 minutes without exception in order to allow for the DC bus capacitors to be fully discharged.

In order to ensure operating and functional safety, all electrical connections must be checked, and all required and mandatory electrical tests for placement into operation and regular operation must be carried out.

Cybersecurity

The combi oven owner must make sure that the measures taken in order to ensure cybersecurity always reflect the current state of the art.

3.5 Hazards posed by the unit

General rules when using the unit

The combi oven has been designed in such a way as to ensure that users will be protected from all hazards that can be reasonably prevented using design-based measures.

However, the combi oven's intended use entails a series of residual risks that will require you to take precautions in order to avoid them. The safety devices and guards on the unit may protect you from some of these risks to a certain extent. However, in order for the safety devices and guards to protect you, you must always make sure that they are in place and working properly.

Following is a description of these residual risks and what kinds of hazards they pose.

Moving heavy loads

During transportation and setup, the following hazards can be posed when moving heavy loads:



Risk of injury due to excessive exertion

When?

- Whenever moving or lifting the unit

How can I avoid the hazard?

- ▷ Use a forklift or pallet jack to place the unit at its installation location or to change its position or location
- ▷ Make sure that a sufficient number of people help correct the unit's position; do not lift or carry too much weight during the process! (Rule of thumb: 30 lbs to a maximum of 120 lbs depending on age and gender.)
- ▷ Comply with all occupational health and safety regulations that apply at the installation location
- ▷ Wear the required personal protective equipment

Loss of unit stability

During transportation and setup, the following hazards can be posed when moving the unit:



Crush hazard for all body parts if the unit falls down

When?

- Whenever moving or lifting the unit

How can I avoid the hazard?

- ▷ Use appropriate transportation equipment
- ▷ Transport equipment slowly and carefully and secure it in such a way that it cannot tip over
- ▷ Keep the unit's center of gravity in mind
- ▷ Avoid bumping into objects

Missing equipotential bonding

The unit can pose the following hazards during all installation work:



Risk of electric shock posed by live parts

Where?

- On the unit and on neighboring metal parts
- On the unit and on neighboring metal accessories

How can I avoid the hazard?

- ▷ Before putting the unit into operation, make sure that it is bonded to an electrical ground system together with all metal accessories

Contact with cleaning agents

The unit can pose the following hazards during all installation work:



Skin, eye, and respiratory tract irritation hazard as a result of contact with cleaning agents and their vapors

When?

- When installing the cleaning system
- Whenever handling cleaning agent containers
- Whenever using aggressive cleaning agents

How can I avoid the hazard?

- ▷ Wear the required personal protective equipment
- ▷ Observe the instructions and warnings on the cleaning agent labels and in the relevant safety data sheets
- ▷ Use specified cleaning agents only

General hazards

In addition to the specified hazards, keep in mind all the general hazards that are found in kitchen environments. For more information, please refer to the 'For Your Safety' in the operating manual.

3.6 Safety Devices

Meaning

The combi oven features a series of safety devices and guards that protect the user from a variety of hazards. All safety devices and guards must be present, fully functional, and locked properly without exception when the combi oven is being used.

Location and functions

The figure below shows a size 6.10 mini combi oven used as an example representing all models:

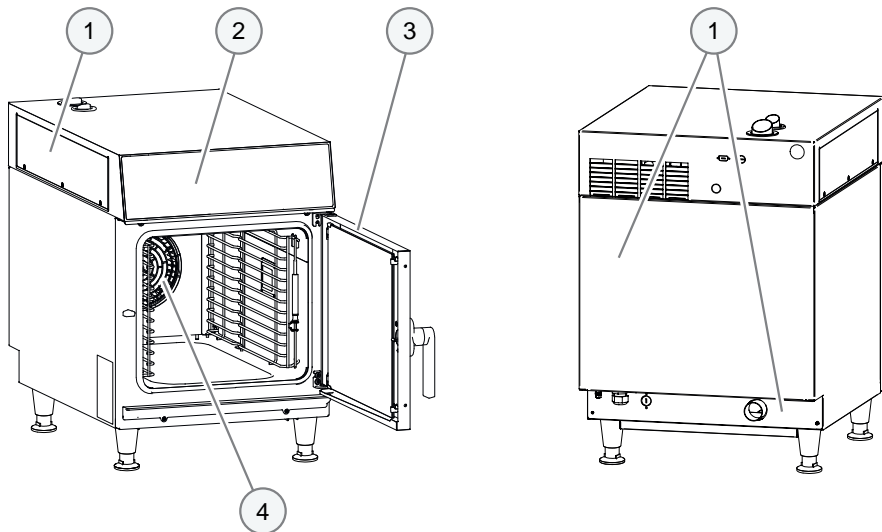

No.	Guard or safety device	Function	Check
1	Covers; can only be removed with tools	<ul style="list-style-type: none"> ▪ Prevents staff from accidentally touching live parts ▪ Prevents staff from reaching into the moving fan inside the wiring compartment 	Check to make sure that the covers are in their proper place
2	Operating panel; can only be removed with tools	Prevents staff from accidentally touching live parts	Check to make sure that the operating panel is in its proper place
3	Unit door	Protects the operator and the surroundings from hot steam	Check for scratches, cracks, and other damage on a regular basis and replace it if you detect any damage
4	Suction panel inside the oven cavity; can only be removed with tools	Prevents staff from reaching into the moving fan and ensures proper heat distribution	Please refer to 'Releasing the Suction Panel and Locking it Back in Place' in the operating manual

No.	Guard or safety device	Function	Check
5 (not shown)	Oven cavity safety thermostat	Turns off the unit if the temperature exceeds the allowable limit	An error code will be output in the event of a fault (Contact a service company that is authorized to reset the safety thermostat)
6 (installed by the customer)	Disconnecter	<ul style="list-style-type: none"> ▪ Installed close to the unit by the customer. Easily visible and accessible, all-pole, with a contact gap of at least 0.12" ▪ Used to de-energize the unit during cleaning, repairs, and maintenance work, as well as in hazardous situations 	Procedure: <ul style="list-style-type: none"> ▪ Trip the disconnecter ▪ Check at the supply terminals to make sure that the unit is properly de-energized

Safety measures

The following measures will contribute to greater safety:

Measure	Function	Check
Unit door solenoid switch (electrical door sensor)	<ul style="list-style-type: none"> ▪ Stops/turns off the following when the unit door is opened: <ul style="list-style-type: none"> ▪ Fan (will stop after a few seconds) ▪ Heating element ▪ Cleaning agent spraying in the fully automatic oven cleaning process ▪ Prompts the user to close the unit door 	Test the door solenoid switch with the combi oven at a low temperature Procedure: <ul style="list-style-type: none"> ▪ Fully open the unit door ▪ Press Start Result: The motor must not start running.
Unit door handle with cracked-open position	<ul style="list-style-type: none"> ▪ Prevents steam coming out from scalding the operator's face and hands 	With the combi oven at a low temperature, check the door positions as described in 'Safely Opening and Closing the Unit Door' in the operating manual
Resuming after a power outage if there was cleaning agent inside the unit when the power went out	<ul style="list-style-type: none"> ▪ Starts the fully automatic oven cleaning process again, from a defined state, after a power outage 	None

3.7 Staff and Work Area Requirements

Staff requirements

The table below specifies the qualifications needed for each role. Provided that they have the required qualifications, a single person can take over more than one role if necessary.

Role	Required qualifications	Tasks
Combi oven owner or the owner's employee who is responsible for the unit and for the staff operating it	Is familiar with the rules involved in handling heavy loads	<ul style="list-style-type: none"> ▪ Briefed on all of the combi oven's safety-relevant functions, mechanisms, and devices by the person placing the unit into operation so that the information can be relayed to all the staff operating the unit ▪ Shown how the unit is operated by the person placing the unit into operation so that the information can be relayed to all the staff operating the unit ▪ If necessary, helping out as directed with transportation within the facilities and with setting up the unit
Mover	<ul style="list-style-type: none"> ▪ Trained in the use of forklifts and/or pallet jacks ▪ Is familiar with the rules involved in handling heavy loads 	Transporting the unit within the facilities
Service technician	<ul style="list-style-type: none"> ▪ Qualified staff from an authorized service company ▪ Has relevant technical training ▪ Has unit-specific training ▪ Is familiar with the rules involved in handling heavy loads ▪ Is able to assess whether the unit's power, water, and drain connections have been correctly set up. 	<ul style="list-style-type: none"> ▪ Setting up the unit ▪ Installing the fully automatic oven cleaning system (optional) ▪ Placing the unit into operation ▪ Removing the unit from service
Electrician	<ul style="list-style-type: none"> ▪ Qualified staff from an authorized service company ▪ Has relevant training ▪ Is a qualified electrician and is familiar with the technical standards that must be applied 	<ul style="list-style-type: none"> ▪ Connecting the unit to the electrical connection at the facilities ▪ Uninstalling electrical connections
Water and wastewater installer	<ul style="list-style-type: none"> ▪ Qualified staff from an authorized service company ▪ Has relevant training 	<ul style="list-style-type: none"> ▪ Connecting the unit to the water connection at the facilities ▪ Uninstalling water connections ▪ Connecting the unit to the drain connection at the facilities ▪ Uninstalling the drain connection
Person placing the unit into operation (service technician)	<ul style="list-style-type: none"> ▪ Is an employee from an authorized service company who is responsible overall for placing the unit into operation ▪ Has relevant technical training ▪ Has unit-specific training ▪ Is familiar with the rules involved in handling heavy loads ▪ Is able to assess whether the unit's power, water, and drain connections have been correctly set up and is familiar with the technical standards that must be applied. 	<ul style="list-style-type: none"> ▪ Briefing the owner or the responsible employee ▪ Checking all steps and conditions as per the checklists

Work areas during installation and placement into operation

During installation and placement into operation, the work area for staff will be the entire area occupied by the unit and its surroundings.

3.8 Personal protective equipment

Transportation and setup

Task	Tools used	Personal Protective Equipment
<ul style="list-style-type: none"> ▪ Transporting the unit within the facilities ▪ Setting up the unit on a work table or stand or inside a stacking kit ▪ Setting up the unit at the installation location 	<ul style="list-style-type: none"> ▪ Appropriate lifting equipment ▪ Carrying straps (for size 10.10 mini) 	<ul style="list-style-type: none"> ▪ Protective gloves ▪ Safety footwear ▪ A hard hat (e. g., when there are suspended loads, doing overhead work)

Load capacity for transportation

Make sure that the transportation equipment you will be using is able to handle the loads it will be transporting.

To determine the minimum load capacity that the transportation equipment must have, check the unit's weight, including its packaging, in the 'Technical Data' on page 57 section.

Installation, placing the unit into operation, and removing it from service

Task	Tools used	Personal Protective Equipment
Installing and uninstalling (removing from service) the following: <ul style="list-style-type: none"> ▪ Electrical connection ▪ Water connection ▪ Drain connection 	Tools and equipment necessary for the specific task at hand	Work clothes and personal protective equipment based on the required task in accordance with country-specific regulations
Installing and uninstalling the fully automatic oven cleaning system (optional)	Tools and equipment necessary for the specific task at hand	The protective equipment required will depend on the cleaning agents being used, and may include: <ul style="list-style-type: none"> ▪ Respirator ▪ Safety eyewear ▪ Protective gloves ▪ Protective clothing/apron Always follow the instructions and observe all warnings found on the labels used for the cleaning agent(s).
<ul style="list-style-type: none"> ▪ Placing the unit into operation ▪ Briefing the user 	Tools and equipment necessary for the specific task at hand	Wear appropriate work clothes for kitchen work as required by your country-specific standards and regulations, especially: <ul style="list-style-type: none"> ▪ Protective clothing ▪ Heat-resistant gloves ▪ Safety footwear
Removing the unit (removing it from service)	<ul style="list-style-type: none"> ▪ Carrying straps ▪ Appropriate lifting equipment ▪ A forklift or pallet jack 	<ul style="list-style-type: none"> ▪ Protective gloves ▪ Safety footwear ▪ A hard hat (e. g., when there are suspended loads, doing overhead work)

4 Transportation

4.1 Transporting the unit to the installation location

Required space during transportation

Make sure that the transportation route you will be following has enough space to accommodate the unit's entire width and height at all times.

The following table lists the dimensions for the units together with their packaging. This list can be used to figure out the required minimum door width and height required in order to be able to get the unit to its intended installation location:

		6.06 mini	6.10 mini	10.10 mini
Width	[in]	22.8	22.8	22.8
Height	[in]	37.6	37.6	47.0
Depth	[in]	29.1	35.8	35.8

Transporting the unit to the installation location for the first time

Observe the following when transporting the unit:

- Always use a pallet to transport the unit.
- Always keep the unit upright when moving it.
- Transport the unit slowly and carefully and secure it in such a way that it cannot tip over.
Make sure not to bump into the unit.
Avoid uneven transportation routes and steep inclinations.

The following additionally applies to unit size 10.10 mini:

- Use a pallet jack or forklift to lift the unit.

4.2 Preparing for Unpacking

Preparing for unpacking

Observe the following before unpacking the unit:

- Check the outer packaging for damage.
- Take the supplemental sheet with unpacking instructions from the shipping documents.

4.3 Included equipment and parts

Unit and accessories

The unit scope consists of the following parts:

- One combi oven
- One left-hand side rack
- One right-hand side rack

Documents

The following documents are enclosed with the unit:

- One installation manual
- One operating manual (hardware)
- One operating instructions document (software)
- One supplemental sheet with unpacking instructions
- One installation and placement-into-operation checklist

5 Setup

5.1 Adjacent Systems

Handling exhaust air

During operation, the combi oven will produce heat and moisture, most of which will escape upwards into the ambient air in the form of hot steam coming through the air vent. Do not connect any lines or ducts directly to the combi oven's air vent!

The manufacturer recommends removing this exhaust air from the combi oven's working area with a range hood or ventilated ceiling.

In order to prevent fire hazards and other structural issues, such as corrosion, mold, and/or a decrease in stability, there must be sufficient clearance between the top of the unit and the ceiling. This clearance must be determined by taking the following into account:

- The reference point for the minimum vertical clearance (refer to 'Installation Location Requirements' on page 31)
- The type of exhaust system being used
- The characteristics of the ceiling at the installation location

The combi oven must always be set up, installed, and operated in compliance with all applicable country-specific and local standards and regulations.

5.2 Installation location requirements

Meaning

This section provides information on how to choose a suitable installation location for the unit. Carefully check the intended installation location to make sure it is adequate before bringing the unit there and starting with the installation!

Setup standards and regulations

All national, state, and local standards and regulations concerning commercial kitchen operations must be complied with. These include, but are not limited to, the Food Code published by the Food and Drug Administration (FDA) (current edition) and the standards published by the National Sanitation Foundation (NSF).

The local rules and regulations that apply to the installation location, as defined by the relevant local authorities and utility companies, must be complied with.

Rules for safely setting up the unit

In order to prevent hazards that may be posed by the installation location and by the unit's surroundings, follow the rules below:

- It must be possible to adhere to the operating conditions at all times. For these operating conditions, please refer to 'Requirements concerning the combi oven's surroundings' on page 16.
- The heat loss at hot surfaces poses a fire hazard. Accordingly, set up the unit in non-combustible environments only.
- There must not be any flammable materials, gases, or liquids at a distance of less than 18" from the sides of the unit (right, left, front, back) and 40" from the top of the unit. When choosing an installation location, make sure to observe this requirement together with the requirements in the 'Adjacent Systems' on page 30 section and the unit's minimum space requirements without exception!
- Substructures (tables, frames) and supporting surfaces (floors, bases, countertops) must be made of non-combustible materials and must not be coated or covered with any flammable materials (no fiberboard, no contact between flammable materials and the bottom of the unit). Likewise, there must not be any flammable materials on the undersides of these structures. The unit supporting surfaces on substructures of this type must project beyond the unit's base on all sides by 12" or more.
- The minimum distance from heat sources in the vicinity of the units is 20".
- The minimum distance that must be maintained between the unit and any deep fryers or open kettle fryers in the vicinity is 40". The unit must be set up in such a way that liquids from the unit and from cooking processes will not be able to get to deep fryers and open kettle fryers under any circumstance. Units mounted on a wall mount must not be placed over a deep fryer, an open kettle fryer, or an electric appliance.
- Do not set up the unit directly under a fire alarm or sprinkler system. The sensitivity of fire alarms and sprinkler systems must be adjusted in line with the amount of vapor and steam that the unit is expected to produce.
- The connection between the combi oven's drain pipe and the sewer system must be located outside the perimeter of the unit's base area. Due to potential wastewater vapors, there must not be a drain connection or open sewer line below the unit's base area.
- It must be possible to set up the unit's base (work table, equipment stand, or stacking kit) at the installation location in such a way that it will not topple over or shift. All supporting surface requirements must be met.
- The unit's base (equipment stand or stacking kit) must be secured in such a way that it cannot topple over if it is subjected to an uneven load (due to an open unit door, for example).
- With its current configuration, the unit is not designed to be used in environments where it could be subjected to strong vibrations or mechanical shock (e.g., on vehicles or ships).
- Vibrations must be avoided when using equipment stands or stacking kits.

Supporting surface requirements

The supporting surface must have the following characteristics:

- The supporting surface must be flat and level.
- The supporting surface must be capable of bearing the unit's weight.
- The countertop or stand must have a load capacity equal to or greater than the unit's empty weight plus the maximum permissible loading weight.

The unit's weight will be made up of the following depending on its specific model and equipment:

- The combi oven's empty weight
- Maximum permissible loading weight
- Maximum cleaning agent weight (with ConvoClean / Convoclean+ option only)
- The weight of the stand or work table

Add the following individual weights to calculate the total unit weight:

		6.06 mini	6.10 mini	10.10 mini
Individual weights				
The combi oven's empty weight	[lbs]	See the weight without packaging in 'Technical Data' on page 57		
Maximum permissible loading weight	[lbs]	29	44	66
Maximum weight of cleaning agents	[lbs]	44	44	44
Equipment stand weight	[lbs]	See the equipment stand weight in 'Technical Data' on page 57		

Space required

In order to ensure that the combi oven will be used safely – especially when it comes to safely handling hot food –, it is necessary to keep a lot more free space in front of the units than is specified in the space requirements!

In order to determine the actual space required between the top of the combi oven and the ceiling, please consult the 'Adjacent Systems' on page 30 section.

Generally speaking, it is recommended to maintain large clearances between the units and the walls in order to make it easier for service staff to access the unit as needed.

Do not cover, obstruct, or block the following parts at the installation location (please refer to 'The Combi Oven's Configuration and Functions on page 11' as well):

- The air vents at the top of the unit
- The dry air intake at the top of the unit
- Vents at the back of the unit
- Opening between the front feet

Required space – width and depth

The following diagrams, as well as the following table, show the space required by the unit for various installation and operating situations, as well as the minimum horizontal clearances required relative to adjacent walls and surfaces. The safety clearances on the left, right, and rear must be maintained without exception.

The figure below shows a size 6.10 mini combi oven used as an example representing all models:

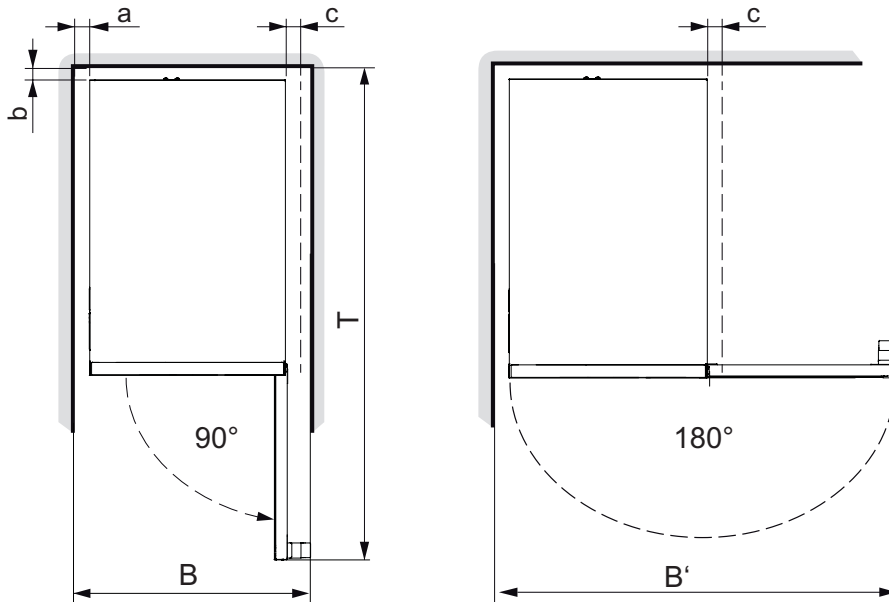

		6.06 mini	6.10 mini	10.10 mini
	Meaning			
B	Minimum required space for the unit width when the door is opened 90°	[in] 24.9	24.9	24.9
B'	Minimum required space for the unit width when the door is opened 180°	[in] 41.5	41.5	41.5
T	Minimum required space for the unit depth (including open door)	[in] 44.8	51.8	51.8
a	Minimum wall clearance on the left side of the unit	[in] 2.0	2.0	2.0
b	Minimum wall clearance at the back of the unit	[in] 2.0	2.0	2.0
c	Minimum wall clearance on the right side of the unit	[in] 2.0	2.0	2.0

Required space – height

The figure below shows a size 6.10 mini combi oven used as an example representing all models:

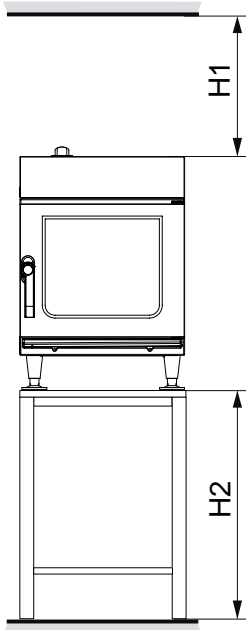

The service technician responsible for setting up the unit must take into account the ceiling's properties and any adjacent systems being used (air ventilation system, range hood) when determining the actual clearance required between the top of the unit and the ceiling. Vertical clearance H1 is only meant to serve as a reference point for the minimum vertical clearance!

Meaning

H1	Reference point for minimum vertical clearance	[in]	20.0
H2	Installation height	[in]	27.6 - 35.4

The topmost shelf must not be at a height exceeding 63".

This requirement will be met automatically if the unit is set up on one of the manufacturer's equipment stands. Please refer to 'Equipment stand dimensions and weights' for more information.

5.3 Removing the unit from the pallet (10.10 mini)

⚠ Rules for safely lifting the unit

- Observe the following rules in order to prevent the unit from toppling over:
- The unit must be carefully lifted and secured in such a way that it will not tip over.
 - Observe the center of gravity.

Removing the unit from the pallet using the carrying straps

To find out how much your unit weighs, consult the 'Technical Data' on page 57 section.

1. Attach the carrying straps (1) to the feet (2).
2. Carefully lift the unit off from the pallet.

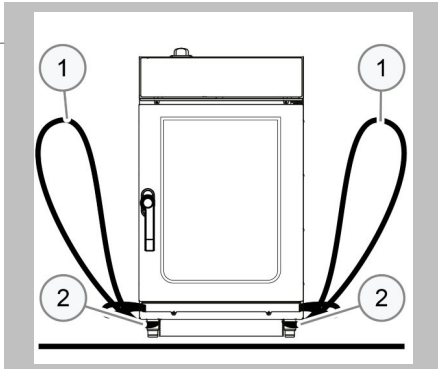

5.4 Setting up the unit on a work table

⚠ Rules for safely setting up the unit

Observe the following rules in order to ensure that the unit will have the required stability:

- It must be possible to set up the work table at the installation location in such a way that it will not topple over or shift. All supporting surface requirements must be met.
- When placed on top of a work table, the unit must be secured in such a way that it will not slide out of place.

Setting up the unit on a work table (6.06/6.10 mini)

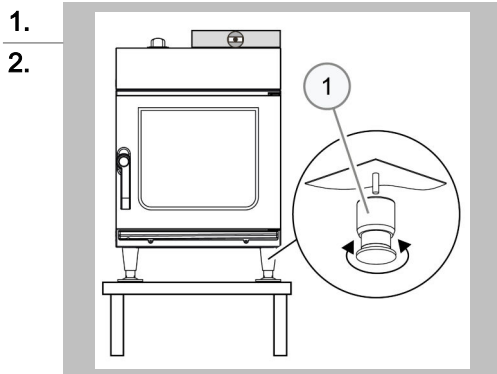

Place the unit on the work table.

Use the enclosed washers (1) to level the unit.
Use a spirit level to make sure that the unit is properly leveled.

Setting up the unit on a work table (10.10 mini)

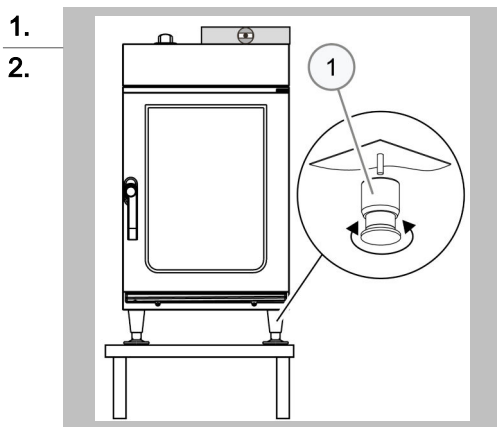

Place the unit on the work table.

Use the unit's height-adjustable feet (1) to level the unit.
Use a spirit level to make sure that the unit is properly leveled.

5.5 Setting Up the Unit on a Stand

⚠ Rules for safely setting up the unit

Observe the following rules in order to ensure that the unit will have the required stability:

- The unit's equipment stand must be secured in such a way that it cannot topple over if it is subjected to an uneven load (due to an open unit door, for example).
- It must be possible to set up the stand at the installation location in such a way that it will not topple over or shift. All supporting surface requirements must be met.

In order to comply with hygiene standards, the following rule must be observed:

- In the case of equipment stands with shelf levels for bakeware, the equipment stands' upper panel must be correctly in place in order to prevent food being temporarily stored in the equipment stand from being contaminated.

Setting Up the Unit on a Stand

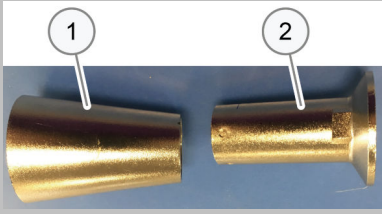
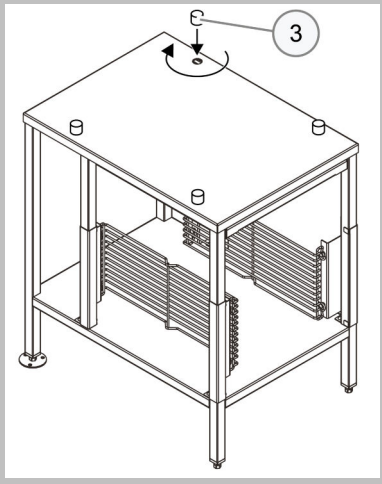
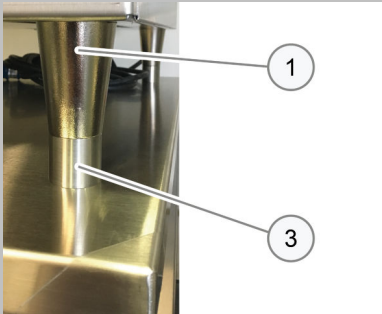
- | | | |
|----|-------------------------------------------------------------------------------------|------------------------------------------------------------------------------------------------------------------------------------------------------------------------------------|
| 1. | | Unscrew the four feet and remove them completely from the unit. |
| 2. |  | Unscrew and remove the lower part (2) of the foot and then screw the upper part (1) of the foot back onto the unit.
You will not be needing the lower part of the foot anymore. |
| 3. |  | Screw the four spacers (3) included with the stand onto the stand. |
| 4. |  | Set the unit on the stand and insert the feet (1) into the sleeve mounts (3) so that they will be securely in place. |

5 Setup

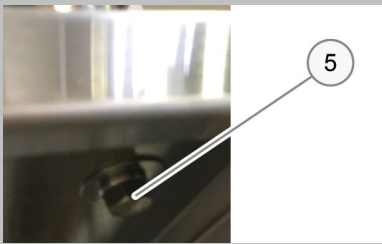
- | | | |
|----|-----------------------------------------------------------------------------------|-----------------------------------------------------------------------------------------------------------------------------------------------------------------|
| 5. |  | Use the enclosed screws (5) to screw the unit onto the equipment stand from below. |
| 6. | | Position the device with the stand and use the height-adjustable feet to level the stand.
Use a spirit level to make sure that the unit is properly leveled. |
| 7. | | Fasten the base on the flange feet. |

5.6 Setting Up Units in a Stacking Kit

⚠ Rules for safely setting up the units in a stacking kit

Observe the following rules in order to ensure that the stacking kit with the units will have the required stability:

- Make sure that the units placed on the top and bottom of the stacking kit are similar in terms of weight.
- Do not, under any circumstance, only place a unit on the top of the stacking kit.
- It must be possible to set up the stacking kit at the installation location in such a way that it will not topple over or shift. All supporting surface requirements must be met.

How to set up the units in the stacking kit

Follow the steps in the separate assembly and installation instructions to install and set up the units in the stacking kit.

6 Installation

6.1 Electrical installation

6.1.1 Planning the Electrical Installation

Meaning

It is crucial for the unit's electrical system to be carefully and correctly installed in order for the unit to run safely and without any problems. All the rules and specifications specified in this section, as well as the procedures described, must be followed to the letter.

⚠ Rules for safely installing the units electrically

In order to prevent hazards related to improperly installed electrical connections, make sure to observe the following rules:

- The unit's case must be properly grounded as per generally accepted standards and practices and connected to an equipotential bonding system.
- If there are two units mounted in a single stacking kit, both the units' cases and the stacking kit must be properly grounded as per generally accepted standards and practices and connected to an equipotential bonding system.
- The field installed conductors must be routed through a flexible conduit.
- While placing the unit into operation, check all electrical cables and connections to make sure they have been routed properly and installed correctly.

Electrical installation standards and regulations

In order to prevent hazards related to improperly installed electrical connections, make sure to observe the following standards and regulations:

- The connection to the power supply must be installed in accordance with the National Electrical Code, ANSI/NFPA 70 (current edition); the Canadian Electrical Code, CSA C22.2; all other applicable national and state laws and regulations; and the local requirements set forth by the relevant local utility companies, trade associations, and authorities.

Equipment provided by the customer and electrical installation rules

The following table shows the equipment that must be provided by the customer and the rules that have to be followed when making the relevant electrical connections.

Equipment	Rules
Fuse	The unit must be fused and connected in accordance with all applicable local regulations and country-specific installation regulations.
Bonding	The unit must be connected to an equipotential bonding system. If there are two units mounted in a single stacking kit, both the units' cases and the stacking kit must be properly connected to an equipotential bonding system. Electrical Bonding: An electrical connection that brings the frames of electrical equipment and other conductive parts to the same or approximately the same potential.
Disconnecter	An easily accessible all-pole power disconnection with a contact gap of at least 0.12" must be installed. The unit must be connected through this power disconnector. The power disconnection will then be used to de-energize the unit before performing cleaning, repair, and installation work. Installation must comply with all applicable local standards and regulations. In the case of permanent installations, a disconnecter is required.

Power supply

The power cord must have the following characteristics:

- Listed, type SO, SOO, STO, STOO, SEO, SJO, SJOO, SJTO, SJTOO, SJEO, HSO, HSOO, HSJO, or HSJOO with or without suffix W.
- Between two to six feet long for counter top mounted or three to ten feet long for floor mounted units.

A warning label must be affixed to the power cord; please refer to 'Warning labels on the combi oven' on page 18.

A specific phase rotation direction or phase sequence is not required when connecting the unit.

6.1.2 Performing the Electrical Installation

Prerequisites

Check whether the following prerequisite is met:

- The unit's connection point has been de-energized and locked and tagged out.

Performing the Electrical Installation

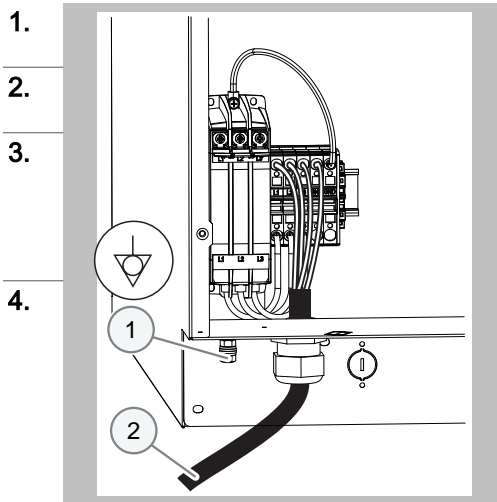

1. Connect the unit to the equipotential bonding system at the intended connection point (1).

2. If necessary, reset the safety thermostat for the oven cavity.

3. Connect the appropriate power plug to the power cord (2). For permissible power plugs, please refer to 'Electrical ratings' in 'Technical Data' (applies exclusively to units that are not already ready to be connected)

4. Carry out the relevant country-specific electrical tests.

6.2 Network Connection

6.2.1 Planning the Network Connection

Meaning

It is crucial for the unit's network connection to be carefully and correctly installed in order for the unit to run safely and without any problems and to have the connection to the Internet required for this purpose.

Contact your service partner for more information.

Equipment provided by the customer and network connection rules

The following table shows the equipment that must be provided by the customer and the rules that have to be followed when making the relevant electrical connections.

Equipment	Rules
RJ45 port	A network jack for the combi oven must be installed close to the unit. If connecting multiple combi ovens, a separate network jack must be installed for each unit. Alternatively, the units can be networked together by installing a router.

Network connection location

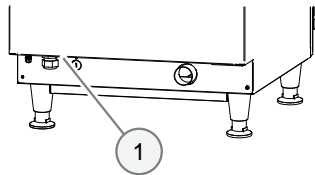



No.	Designation	Function
1	RJ45 port	Network connection on connecting bracket at the back of the combi oven

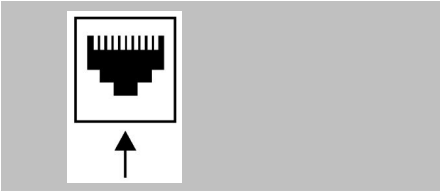

6.3 Making the Network Connection

Installation steps

To establish an Internet connection, follow the steps below:

1.  Use a network cable to connect the combi oven's network port to the network jack preinstalled and intended for this use by the customer.
2.  When placing the combi oven into operation, check whether the 'kitchenconnect®' Internet icon indicates an active connection on the user interface.

Checking the network connection

Display in easyTouch	Button	Meaning
	'kitchenconnect®' white	Internet is active, installation successful
	'kitchenconnect®' gray	Internet is not active, installation unsuccessful

6.4 Water connection

6.4.1 Water supply

Water connection standards and regulations

Make sure to comply with all national and state laws and regulations that apply to the water connection, as well as with all applicable local requirements and regulations set forth by the relevant local water utilities and authorities. These include, but are not limited to:

- Latest edition of the International Plumbing Code published by the International Code Council (ICC) or the Uniform Plumbing Code published by the International Association of Plumbing and Mechanical Officials (IAPMO)
- The Food Service Sanitation Manual published by the Food and Drug Administration (FDA)
- The standards published by the National Sanitation Foundation (NSF)

The unit must be installed with an appropriate backflow preventer in order to comply with all applicable federal, state, and local laws and regulations.

Water connection configuration

The unit is designed for a permanent connection to the water supply via a connecting hose with a minimum diameter of 1/2".

The following parts are required for a proper water connection.

- Two 3/4" water supply lines

Water quality and water hardness





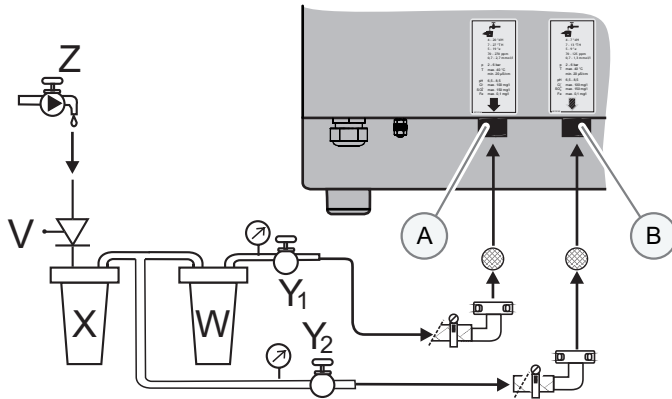



- Ask your local water company for information regarding the quality and hardness of the water you get or check the water quality as explained in 'Checking the Water Quality' on page 48.
- For information on the required properties for the drinking water used with the unit, please refer to 'Technical Data' on page 57 section.
- If required, use suitable water treatment solutions. These can include, for instance, installing a water filter and/or a full water treatment system.
- Follow the steps in the 'Checking the Water Quality' section in order to ensure that the required water quality values are met once the water goes through your water treatment system.

Connection diagram with water treatment system

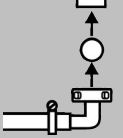

No.	Designation	Explanation
A	Soft water connection	For drinking water quality information, refer to the 'Technical Data' on page 57 section
B	Cold water connection	
Z	Water supply provided by the customer	Drinking water quality
X	0.003" sediment filter	A 0.003" sediment filter needs to be installed if the water has a lot of impurities.
W	Water treatment system	If the required values are exceeded, a water treatment system must be installed.
Y	Shut-off device with mesh strainer	Water valve
V	Appropriate backflow preventer	The unit must be installed with an appropriate backflow preventer in order to comply with all applicable federal, state, and local laws and regulations.

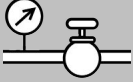
Installing the water supply connection

1.		Flush the water connection on the on-site water line (Z).
2.		Install the sediment filter (X) and, if necessary, a water treatment system (W).
3.		Install a separate shut-off device with a mesh strainer for each unit (Y or Y ₁ /Y ₂).
4.		Install an appropriate backflow preventer (V) in the water supply line if required by local regulations.
5.		Connect the unit as shown in the 'Connection drawing' on page 64.
6.		Flush the sediment filter under running water.
7.		Once you are done installing the water connection, close the shut-off device.
8.		Inform the user of the maintenance intervals for the filters and for the water treatment system (if any).

6.4.2 Checking the water quality

Required tools:

You will need the following tools:

- 1 sample jar for getting a sample
- 1 conductivity meter (part No. [3019007](#))
- A general hardness and carbonate hardness analysis kit, including two beakers (part No. [3019010](#))
- Protective gloves

Checking the water quality:

Measure the water's conductivity and total hardness. To do so, follow the instructions for the meter and the analysis kit.

Compare the measured values with the required values in the 'Technical Data' on page 57 section.

6.4.3 Drain connection

Drain connection standards and regulations

Make sure to comply with all national and state laws and regulations, as well as with all applicable local requirements and regulations set forth by the relevant local utilities and authorities, that apply to the drain connection and to the wastewater's properties. These include, but are not limited to:

- Latest edition of the International Plumbing Code published by the International Code Council (ICC) or the Uniform Plumbing Code published by the International Association of Plumbing and Mechanical Officials (IAPMO)
- The Food Service Sanitation Manual published by the Food and Drug Administration (FDA)
- The standards published by the National Sanitation Foundation (NSF)

Rules for safely installing the drain connection

In order to prevent hazards related to an improperly installed drain connection, make sure to observe the following rules:

- The drain pipes' material must be able to withstand a sustained temperature of 140 °F.
- The drain pipe must not taper or have any other diameter-reducing deformations at any point.
- The drain pipe's minimum diameter will depend on the pipe's total length and the number of elbows used. For a pipe length of up to 6 feet and a maximum of two elbows, the minimum inner diameter will be 1½". For a pipe length of 6 to 12 feet or a maximum of three elbows, the minimum inner diameter will be 2".
- The drain pipe must have a downward slope of min. 5% (3°)
- Do not directly connect the unit drain to the sewer system vertically.
- The connection between the drain pipe and the sewer system must be located outside the perimeter of the unit's base area. Due to potential wastewater vapors, there must not be a drain connection or open sewer line below the unit's base area.
- The drain connection must be implemented using a rigid, naturally ventilated pipe.
- A ventilation clearance of at least 1" must be maintained between the end of the drain pipe and the upper edge of the drain or pan.
- Do not connect any other units to the combi oven's drain pipe.
- Do not connect the combi oven to any other units' drain pipe.

Connection diagram

The figure below shows a size 6.10 mini combi oven used as an example representing all models:

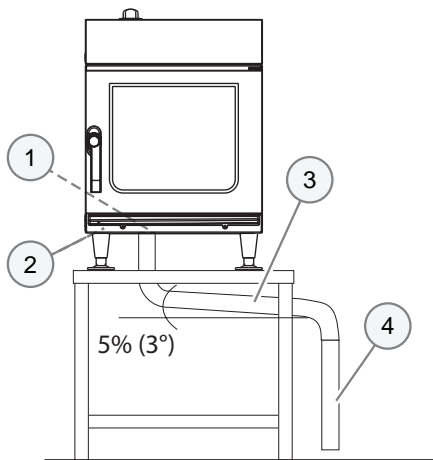

No.	Designation	Function
1	Drain Connection	At the back of the unit, connection point C – please refer to 'Connection drawing' on page 64
2	Safety overflow	<ul style="list-style-type: none"> ▪ At the bottom of the unit, connection point M – please refer to 'Connection drawing' on page 64 ▪ Used to drain water in the event of a failure (blockage)
3	1½" drain pipe	<ul style="list-style-type: none"> ▪ Minimum inner diameter = 1½" ▪ Downward slope: min. 5% (3°)
4	1½" (2") drain pipe	<ul style="list-style-type: none"> ▪ Minimum inner diameter = 1½" (2") ▪ Downward slope: min. 5% (3°)

Installing the drain connection

Connect the unit as shown in the connection diagram.

6.5 Installing the ConvoClean System (for Units with ConvoClean / ConvoClean+)

6.5.1 Components of Fully Automatic Oven Cleaning System

Cleaning agents and rinse aid

Only use the products specified here in order to clean the combi oven.

NOTICE! The warranty will be void if there is any damage that can be traced back to the use of incorrect cleaning agents.

The following table lists the cleaning agents and rinse aids that can be used:

Designation	Product	Label color
Cleaning agents	ConvoClean forte	Red
Rinse aid	ConvoCare	Green

Components and Configuration of Fully Automatic Oven Cleaning System with Connected Canisters

The figure below shows a size 6.10 mini combi oven used as an example representing all models:

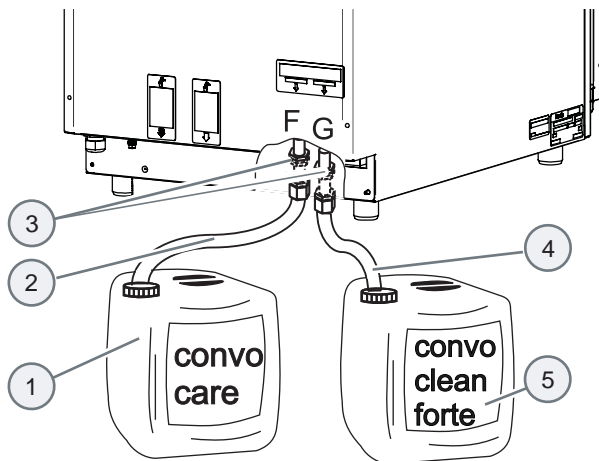

No.	Designation	Color coding
F	Unit connection for rinse aid	Green (inscription)
G	Unit connection for cleaning agent	Red (inscription)
1	Canister with ConvoCare rinse aid (ready-to-use solution with a defined mix ratio)	Green (label)
2	Suction tube with suction nozzle for rinse aid	Green (tube)
3	D10 wire hose clamp	-
4	Suction tube with suction nozzle for cleaning agent	Red (tube)
5	Canister with ConvoClean forte cleaning agent	Red (label)

Installation location for cleaning agent and rinse aid canisters

Set up the canisters as follows:

- The canisters should be easily accessible on a flat, level surface next to the device.
- The canister's supporting surface must not be higher than the edge where the feet and the unit case meet.
- The canister's supporting surface must not be more than 40" below this edge.

6.5.2 Connecting the Fully Automatic Cleaning System

⚠ Rules for safely connecting the fully automatic oven cleaning system

Getting the ConvoClean and ConvoCare connections mixed up may pose a risk of injury or illness when food cooked afterwards is eaten.

In order to prevent this risk, make sure to observe the following rules:

- When connecting ConvoClean forte and ConvoCare, make absolutely sure that the hoses are connected to the right fitting and the right canister cap.

Prerequisites

- Cold water connection as specified in the 'Water Supply' on page 45 section
- Drain connection as specified in the 'Drain connection' on page 49 section
- Technical prerequisites as specified in the 'Technical Data' on page 57 section

Connecting the fully automatic oven cleaning system with canisters

1.		Slip the green suction tube (2) for ConvoCare rinse aid onto the barbed nipple on the rear bulkhead fitting (F) and secure the tube using the wire hose clamp (3) (see 'Rinse-aid connection' adhesive label at the back of the unit).
2.		Insert the suction nozzle on the green suction tube (2) into the rinse aid canister (1). The tube must be routed without any kinks and the canister's vent opening must be open and clear.
3.		Slip the red suction tube (4) for ConvoClean forte cleaning agent onto the barbed nipple on the front bulkhead fitting (G) and secure the tube using the wire hose clamp (3) (see 'Cleaning-agent connection' adhesive label at the back of the unit).
4.		Insert the suction nozzle on the red suction tube (4) into the cleaning agent canister (5). The tube must be routed without any kinks and the canister's vent opening must be open and clear.
5.		Start a cleaning sequence with the 1st setting and check to make sure that cleaning agent is sprayed inside.

Optional customization

Optionally, an authorized service company, or the manufacturer, can customize the ConvoClean system as per the operator's wishes (service manual).

7 Placing into operation

7.1 Working Safely When Putting the Unit Into Operation

For your safety when working with/on the combi oven

Before placing the combi oven into operation, read and understand the rules, risks, and hazards specified in the 'For Your Safety' on page 14 section and follow all the corresponding instructions without exception. Follow the relevant instructions in the operating manual when testing cooking and cleaning sequences.

Basic rules for safe operation

If the combi oven is moved in an impermissible manner after installation (on purpose or by accident), do not continue to operate the unit unless all the following requirements are met:

- The unit and the accessories being used do not have any obvious damage.
- The supply lines installed for electrical power, water, wastewater, and cleaning agents do not have any obvious damage, have a secure fit, are not dripping anywhere, and appear to be safe and fully functional after a visual inspection.
- The 'Requirements concerning the combi oven's functional capability on page 16' are being met.
- The 'Requirements concerning the combi oven's surroundings on page 16' are being met.
- All warning labels are at their intended location.

Rules for safely running the unit

In order to avoid hazards, follow the rules below when running the unit:

- Make sure to only use your hands when using the unit's controls (buttons, switches, touchscreens).
- Do not cover, obstruct, or block the air vent or the dry air intake at the top of the unit, the vents at the back of the unit, or the openings on the bottom side in the front area between the feet.
- The racks need to be locked in place.
- Bakeware must be slid in properly; please refer to 'Placing Food Inside and Taking It Out' in the operating manual.
- The suction panel needs to be properly locked in place.

7.2 Procedure for Placing the Unit into Operation

Checks before placing the unit into operation

Before putting the combi oven into operation, check whether the prerequisites below are being met:

- The unit does not have any obvious damage.
- The unit has been set up in such a way that it will not shift or topple over; the requirements concerning the location and the unit's surroundings are met (please refer to the 'Setup' on page 30).
- Protective films, cardboard, securing devices for shipping, etc., have been removed completely.
- There is nothing being stored inside the oven cavity and there is nothing inside the oven cavity other than required cooking accessories (food containers, for example).
- The unit has been installed as per the specifications in the 'Installation' on page 40 section.
- The supply lines installed for electrical power, water, wastewater, and cleaning agents do not have any obvious damage, have a secure fit, are not dripping anywhere, and appear to be safe and fully functional after a visual inspection.
- The unit has been subjected to an individual electric inspection (see below).
- All safety guards and devices are in their intended place and are working properly.
- All warning labels are at their intended location.
- The unit and the accessories being used must have been cleaned properly.

Do not place the unit into operation unless all specified prerequisites are met.







Individual electric inspection

An individual electric inspection includes the following three steps:





- Inspection: Visual inspection for damage and improper use
- Measurement: Measurements performed as per generally accepted standards and practices (equipment grounding conductor resistance, insulation resistance, equipment grounding conductor current / leakage current)
- Testing: Functional test

The individual electric inspection must be repeated at regular intervals as required by law.

Preparing to place the unit into operation

1.		Bring the ambient temperature to the permissible operating temperature.
2.		Turn on the circuit breaker.
3.		Open the water supply.
4.		Check to make sure that the following are installed properly in the right position: <ul style="list-style-type: none"> ▪ Suction panel ▪ Racks
5.		Turn the combi oven on.
6.		Set the following: <ul style="list-style-type: none"> ▪ Date ▪ Time ▪ Language

Placing the unit into operation

1.		Start the cooking sequence using the following cooking data: <ul style="list-style-type: none">▪ 'Combi-steam' cooking mode▪ 300 °F▪ 10 minutes
2.		Check the following: <ul style="list-style-type: none">▪ Is the oven light on?▪ Is the fan wheel running?▪ Are there any leaks in the wastewater and supply water systems?▪ Is the temperature increasing inside the oven cavity?
3.		Start the cooking sequence using the following cooking data: <ul style="list-style-type: none">▪ 'Steam' cooking mode▪ 210 °F▪ 10 minutes
4.		Check whether steam is being produced inside the oven cavity (carefully open the unit door).
5.		With the ConvoClean / ConvoClean+ option: Check the ConvoClean fully automatic cleaning system: <ul style="list-style-type: none">▪ Start the fully automatic cleaning sequence.▪ Check that ConvoClean forte and ConvoCare are being properly supplied.

Briefing the user

Brief the user on all safety-relevant functions, mechanisms, and devices. Show the user how to operate the unit and fill out the checklist enclosed with the unit.

Warranty information

Warranty claims involving your combi oven will only be honored if the unit has been installed by a qualified service technician from an authorized service company as per the instructions in this installation manual. Please note that warranty claims will only be honored if the manufacturer has a copy of the fully completed checklist from the installation manual.

The warranty will be void if there is any damage that can be traced back to improper setup, installation, use, cleaning, use of cleaning agents, maintenance, repair, or descaling.

In order to get a two-year extended warranty for spare parts, the unit needs to be registered on the manufacturer's website (www.convotherm.de) after installation.

8 Removing from Service and Disposal

8.1 Removing from Service and Disposal

Rules for working safely and responsibly when removing the unit from service

Avoid endangering yourself and others by following the rules below:

- Before being worked on, the unit must always be de-energized and locked and tagged out. In addition, it is necessary to double-check that it has actually been de-energized properly.
- The unit must be carefully lifted and secured in such a way that it will not tip over.
- Observe the center of gravity.
- Cleaning agents must be disposed of as instructed in the canisters in order to avoid damaging the environment.

Prerequisites

Check the following before removing the unit from service:

- The unit has been de-energized.
- The water supply has been shut off.

Removing from service

To remove your unit from service, undo all setup and installation work step-by-step in opposite order (please refer to the 'Installation' on page 40, 'Transportation' on page 28, and 'Setup' on page 30 sections).

Do not move the unit before disconnecting all of its connections.

The following work must be done properly in order to remove the unit from service:

- Removing the unit's water connection
- Removing the unit's drain connection
- Removing or disconnecting the electrical connections
- Removing the door lock
- Properly disposing of all cleaning agents as indicated on the cleaning agent containers and in any applicable country-specific and local regulations.

For units with fully automatic oven cleaning:

- Removing the cleaning agent and rinse aid connections

Disposal

Contact the manufacturer in order to arrange for your unit to be disposed of in an environmentally responsible manner. The manufacturer has an ISO 14001:2004-certified environmental management system and will dispose of your old unit in compliance with all applicable environmental protection regulations.

9 Technical data

9.1 Dimensions and weights

Dimensions and weights

		6.06 mini	6.10 mini	10.10 mini
Width				
With packaging	[in]	22.8	22.8	22.8
Without packaging	[in]	20.3	20.3	20.3
Depth				
With packaging	[in]	29.1	35.8	35.8
Without packaging	[in]	23.6	30.6	30.6
Height				
With packaging	[in]	37.6	37.6	47.0
Without packaging (standard)	[in]	27.6	27.6	47.0
Without packaging (easyTouch)	[in]	29.1	29.1	37.0
Weight (without ConvoClean option)				
With packaging	[lbs]	128	148	181
Without packaging	[lbs]	101	119	152
Weight (with ConvoClean option)				
With packaging	[lbs]	126	150	183
Without packaging	[lbs]	99	121	154
Safety clearances				
Rear	[in]	2.0	2.0	2.0
Right-hand side	[in]	2.0	2.0	2.0
Left-hand side (larger gap recommended for servicing)	[in]	2.0	2.0	2.0
Above (for ventilation)	[in]	20.0	20.0	20.0

Equipment stand dimensions and weights

		6.06 mini	6.10 mini	10.10 mini
Equipment stand dimensions and weights				
Width	[in]	20.3	20.3	20.3
Depth	[in]	18.7	25.7	25.7
Height	[in]	35.4	35.4	27.6
Weight	[lbs]	21	26	23
Total height with equipment stand (standard)	[in]	64.3	64.3	64.3
Total height with equipment stand (easyTouch)	[in]	65.7	65.7	65.7

9.2 Maximum permissible loading weight

Maximum permissible loading weight

The total weight placed on the shelf levels must not exceed the combi oven's maximum permissible loading weight. For more information on loading details, please refer to the operating manual:

		6.06 mini	6.10 mini	10.10 mini
Maximum load weight				
Per combi oven	[lbs]	29	44	66
Per shelf	[lbs]	11	11	11

9.3 Electrical supply

Electrical supply

		6.06 mini	6.10 mini	10.10 mini
3~ 208/240 V 60 Hz (3/PE)		(for 208 V)		
Rated power consumption	[kW]	4.5	5.65	8.50
Hot air output (RHK rated output)	[kW]	5	6.8	10.2
Motor output	[kW]	0.25	0.25	0.25
Rated current	[A]	12.5	15.7	23.6
Recommended supply connection				
Supply cord 4 wire, two to six feet long	AWG	10	10	10
Recommended supply connection: ground wire	AWG	10	10	10
Conductor insulation rating		SO, SOO, STO, STOO, SEO, SJO, SJOO, SJTO, SJTOO, SJEO, HSO, HSOO, HSJO, or HSJOO with or without suffix W		
Permissible connectors	NEMA	15-30P or L15-30P 15-50P or L15-50P		
Ground fault circuit interrupter (GFCI)		according to UL 943 NEC NFPA70		
3~ 208/240 V 60 Hz (3/PE)		(for 240 V)		
Rated power consumption	[kW]	5.9	7.45	11.25
Hot air output (RHK rated output)	[kW]	5	6.8	10.2
Motor output	[kW]	0.25	0.25	0.25
Rated current	[A]	14.2	17.9	27.1
Recommended supply connection				
Supply cord 4 wire, two to six feet long	AWG	10	10	8
Recommended supply connection: ground wire	AWG	10	10	8
Conductor insulation rating		SO, SOO, STO, STOO, SEO, SJO, SJOO, SJTO, SJTOO, SJEO, HSO, HSOO, HSJO, or HSJOO with or without suffix W		
Permissible connectors	NEMA	15-30P or L15-30P 15-50P or L15-50P		
Ground fault circuit interrupter (GFCI)		according to UL 943 NEC NFPA70		

		6.06 mini	6.10 mini	10.10 mini
3~ 208 V 60 Hz (3/PE)				
Rated power consumption	[kW]	4.5	5.65	8.50
Hot air output (RHK rated output)	[kW]	5	6.8	10.2
Motor output	[kW]	0.25	0.25	0.25
Rated current	[A]	12.5	15.7	23.6
Recommended supply connection				
Supply cord 4 wire, two to six feet long	AWG	10	10	10
Recommended supply connection: ground wire	AWG	10	10	10
Conductor insulation rating		SO, SOO, STO, STOO, SEO, SJO, SJOO, SJTO, SJTOO, SJEO, HSO, HSOO, HSJO, or HSJOO with or without suffix W		
Permissible connectors	NEMA	15-30P or L15-30P 15-50P or L15-50P		
Ground fault circuit interrupter (GFCI)		according to UL 943 NEC NFPA70		
3~ 240 V 60 Hz (3/PE)				
Rated power consumption	[kW]	5.9	7.45	11.25
Hot air output (RHK rated output)	[kW]	5	6.8	10.2
Motor output	[kW]	0.25	0.25	0.25
Rated current	[A]	14.2	17.9	27.1
Recommended supply connection				
Supply cord 4 wire, two to six feet long	AWG	10	10	8
Recommended supply connection: ground wire	AWG	10	10	8
Conductor insulation rating		SO, SOO, STO, STOO, SEO, SJO, SJOO, SJTO, SJTOO, SJEO, HSO, HSOO, HSJO, or HSJOO with or without suffix W		
Permissible connectors	NEMA	15-30P or L15-30P 15-50P or L15-50P		
Ground fault circuit interrupter (GFCI)		according to UL 943 NEC NFPA70		
1N~ 208V 60Hz (1N/PE)				
Rated power consumption	[kW]	5.45	5.45	-
Hot air output (RHK rated output)	[kW]	5	5	-
Motor output	[kW]	0.25	0.25	-
Rated current	[A]	26.2	26.2	-
Recommended supply connection				
Supply cord 4 wire, two to six feet long	AWG	10	10	-
Recommended supply connection: ground wire	AWG	10	10	-
Conductor insulation rating		SO, SOO, STO, STOO, SEO, SJO, SJOO, SJTO, SJTOO, SJEO, HSO, HSOO, HSJO, or HSJOO with or without suffix W		
Permissible connectors	NEMA	6-50P or L6-50P		
Ground fault circuit interrupter (GFCI)		according to UL 943 NEC NFPA70		

1~ 240 V 60 Hz (1/PE)				
Rated power consumption	[kW]	5.9	-	-
Hot air output (RHK rated output)	[kW]	5	-	-
Motor output	[kW]	0.25	-	-
Rated current	[A]	24.5	-	-
Recommended supply connection				
Supply cord 4 wire, two to six feet long	AWG	10	-	-
Recommended supply connection: ground wire	AWG	10	-	-
Conductor insulation rating		SO, SOO, STO, STOO, SEO, SJO, SJOO, SJTO, SJTOO, SJEO, HSO, HSOO, HSJO, or HSJOO with or without suffix W		
Permissible connectors	NEMA	6-50P or L6-50P	-	-
Ground fault circuit interrupter (GFCI)		according to UL 943 NEC NFPA70	-	-

9.4 Heat loss

Heat loss

		6.06 mini	6.10 mini	10.10 mini
Heat loss				
Latent	[BTU/h]	955	1263	1740
Sensible	[BTU/h]	1058	1365	1911

9.5 Water connections

Water connections

Water supply (cold only)		
Shut-off device		The unit may need to be installed with an appropriate backflow preventer in order to comply with all applicable federal, state, and local laws and regulations.
Water supply		Two 3/4" inner diameter GHT-M (garden hose adapter). The unit is designed for a permanent hookup to the water supply that uses a connecting hose with a minimum diameter of 1/2"
Flow pressure	[psi]	29 – 87 (2 – 6 bar)
Flow pressure (with ConvoClean / Convoclean + option)	[psi]	43.5 - 87 (3 - 6 bar)
Water drain		
Version		Naturally ventilated pipe to open pan or drain/channel, min. 1" ventilation clearance
Type	[in]	Depending on the length of the line and the elements used in the line, the minimum inner diameter of the line is 1½" or 2"
Drain temperature	[°F]	140
Slope for drain pipe		min. 5% (3°)
Safety overflow	[inch]	2.36" x 0.79"

9.6 Water quality

Water quality

Water hardness for water injection		
Water quality		<ul style="list-style-type: none"> ▪ Drinking water ▪ Soft water
Hardness	[ppm]	70 - 125 (4 - 7 gpg)
TDS (total dissolved solids)	[ppm]	70 - 125
Total alkalinity	[ppm]	50 - 100
Water hardness for cleaning		
Water quality		<ul style="list-style-type: none"> ▪ Drinking water ▪ Hard water (or soft water; see above for specification)
Hardness	[ppm]	70 - 360 (4 - 21 gpg)
TDS (total dissolved solids)	[ppm]	70 - 360
Total alkalinity	[ppm]	50 - 100
Figures		
Temperature	[°F]	max. 104
pH value		6.5 - 8.5
Cl ⁻ (chloride)	[ppm]	max. 60
Cl ₂ (free chlorine)	[ppm]	max. 0.2
SO ₄ ²⁻ (sulfate)	[ppm]	max. 150
Fe (iron)	[ppm]	max. 0.1
SiO ₂ (silicate)	[ppm]	max. 13
NH ₂ Cl (monochloramine)	[mg/l]	max. 0.2

9.7 Water consumption

Water consumption

		6.06 mini	6.10 mini	10.10 mini
Cold water (without ConvoClean / ConvoClean+ option)				
Average water consumption	[gph]	0 - 4.0	0 - 4.0	0 - 4.0
Peak consumption	[gpm]	0.1	0.1	0.1
Cold water (with ConvoClean / ConvoClean+ option)				
Average water consumption	[gph]	0 - 5.3	0 - 5.3	0 - 5.3
Peak consumption	[gpm]	1.9	2.6	2.6
Soft water				
Average water consumption for sizing the water filter	[gph]	0 - 4.0	0 - 4.0	0 - 4.0

10 Connection drawings

10.1 Dimensions and Connection Points (Standard)

mini 6.06 dimensions and connection points (right-hinged unit door)

Front view

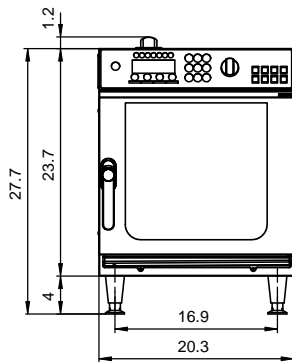

Side view

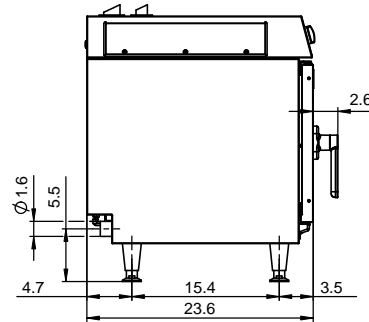

View from above with wall clearances

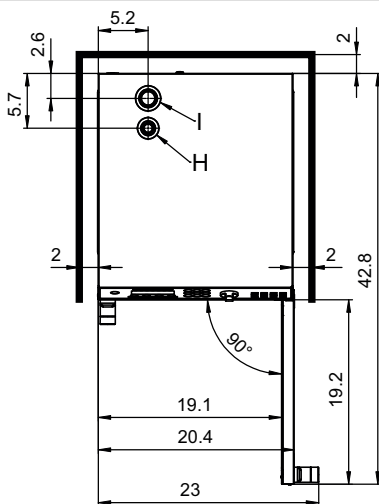

Connections at bottom of unit

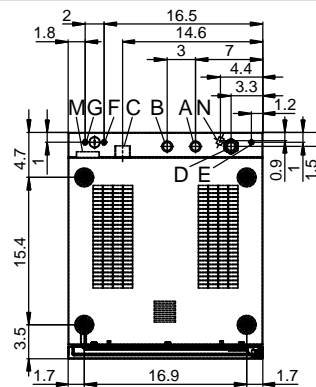

Rear view

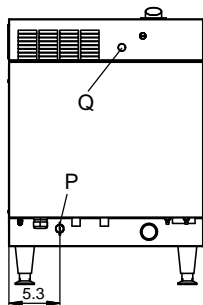

Key

- A Water connection (soft water (filtered), for water injection)
- B Water connection (cold water (unfiltered), for cleaning)
- C Drain connection 1.5"
- D Electrical connection
- E Bonding
- F Rinse-aid connection
- G Cleaning-agent connection
- H Air vent \varnothing 1.18"
- I Ventilation port \varnothing 1.69"
- M Safety overflow 2.36" x 0.79"
- N RJ45 Ethernet port
- P mini Condensation Hood Pro - optional
- Q Used to reset the thermal cutout

mini 6.10 dimensions and connection points (right-hinged unit door)

Front view

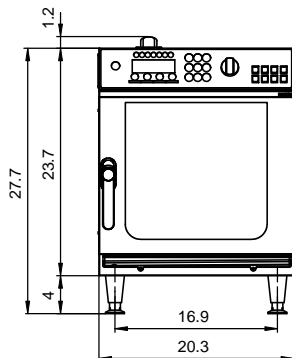

Side view

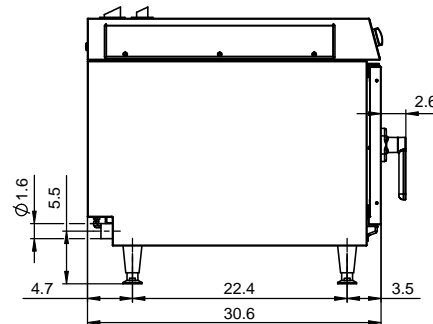

View from above with wall clearances

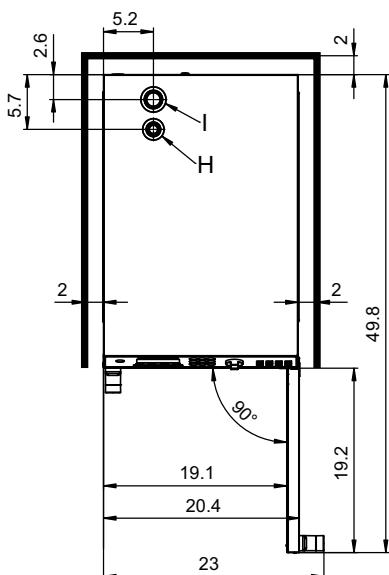

Connections at bottom of unit

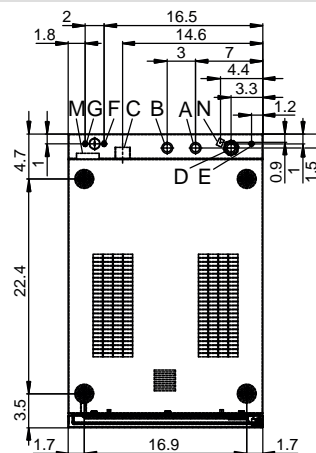

Rear view

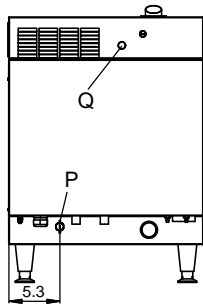

Key

- A Water connection (soft water (filtered), for water injection)
- B Water connection (cold water (unfiltered), for cleaning)
- C Drain connection 1.5"
- D Electrical connection
- E Bonding
- F Rinse-aid connection
- G Cleaning-agent connection
- H Air vent \varnothing 1.18"
- I Ventilation port \varnothing 1.69"
- M Safety overflow 2.36" x 0.79"
- N RJ45 Ethernet port
- P mini Condensation Hood Pro - optional
- Q Used to reset the thermal cutout

mini 10.10 dimensions and connection points (right-hinged unit door)

Front view

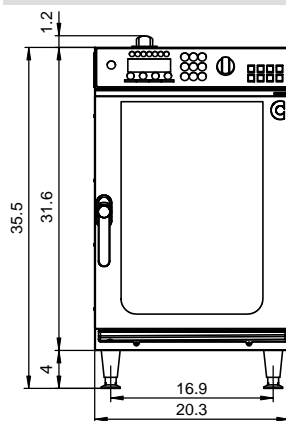

Side view

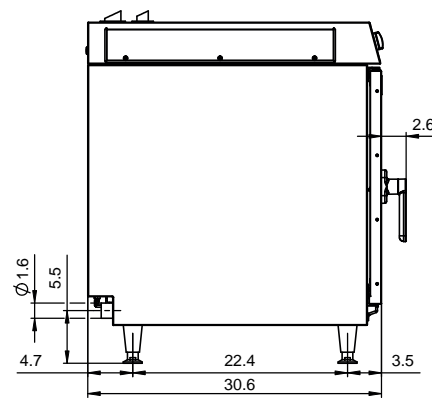

View from above with wall clearances

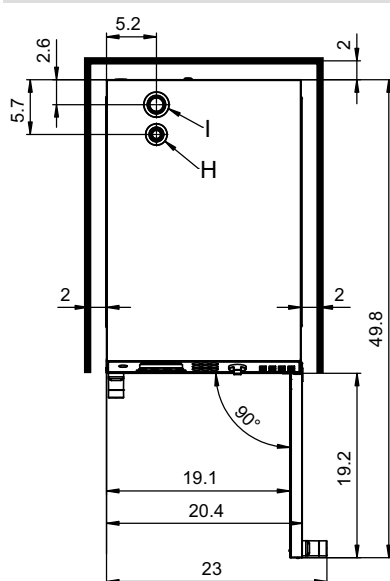

Connections at bottom of unit

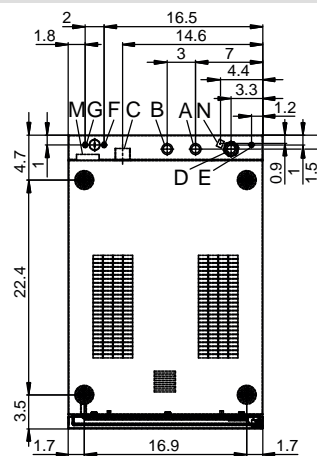

Rear view

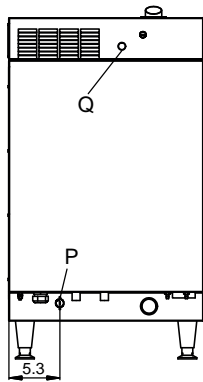

Key

- A Water connection (soft water (filtered), for water injection)
- B Water connection (cold water (unfiltered), for cleaning)
- C Drain connection 1.5"
- D Electrical connection
- E Bonding
- F Rinse-aid connection
- G Cleaning-agent connection
- H Air vent \varnothing 1.18"
- I Ventilation port \varnothing 1.69"
- M Safety overflow 2.36" x 0.79"
- N RJ45 Ethernet port
- P Accessory CH Pro condensation hood - optional
- Q Used to reset the thermal cutout

10.2 Dimensions and Connection Points (easyTouch)

mini 6.06 dimensions and connection points (right-hinged unit door)

Front view

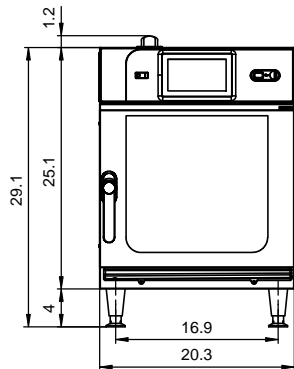

Side view

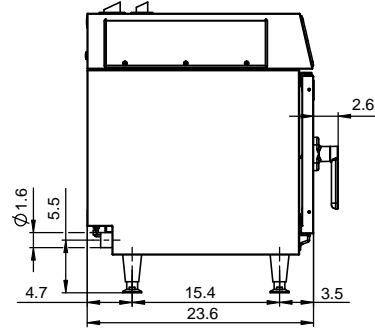

View from above with wall clearances

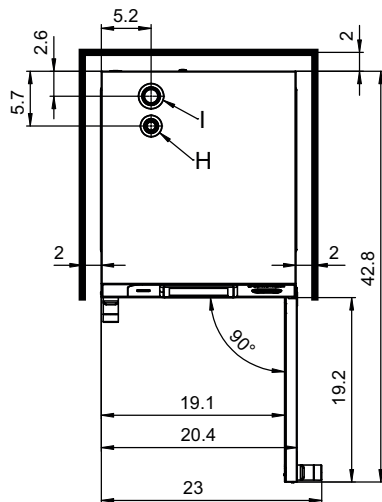

Connections at bottom of unit

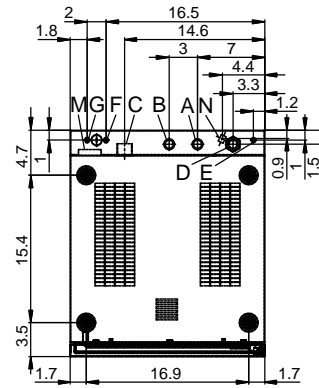

Rear view

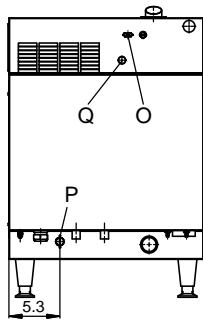

Key

- A Water connection (soft water (filtered), for water injection)
 - B Water connection (cold water (unfiltered), for cleaning)
 - C Drain connection 1.5"
 - D Electrical connection
 - E Bonding
 - F Rinse-aid connection
 - G Cleaning-agent connection
 - H Air vent \varnothing 1.18"
 - I Ventilation port \varnothing 1.69"
 - M Safety overflow 2.36" x 0.79"
 - N RJ45 Ethernet port
 - O ConvoVent mini condensation hood by Halton (RS232) - - optional
 - P Accessory CH Pro condensation hood - optional
 - Q Used to reset the thermal cutout
-

mini 6.10 dimensions and connection points (right-hinged unit door)

Front view

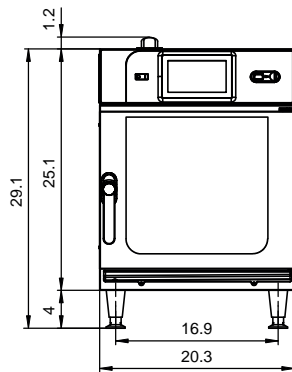

Side view

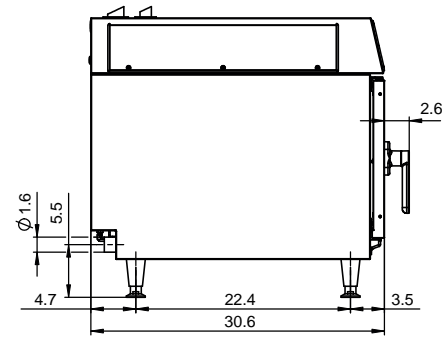

View from above with wall clearances

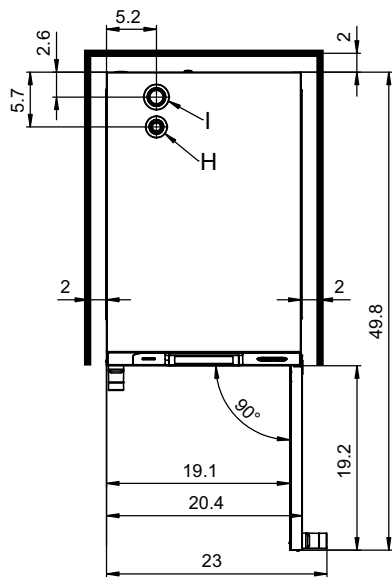

Connections at bottom of unit

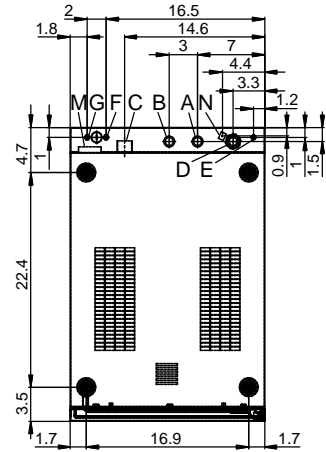

Rear view

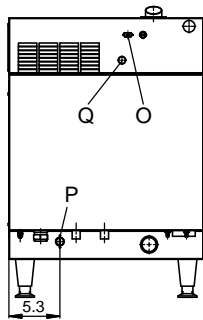

Key

- A Water connection (soft water (filtered), for water injection)
- B Water connection (cold water (unfiltered), for cleaning)
- C Drain connection 1.5"
- D Electrical connection
- E Bonding
- F Rinse-aid connection
- G Cleaning-agent connection
- H Air vent \varnothing 1.18"
- I Ventilation port \varnothing 1.69"
- M Safety overflow 2.36" x 0.79"
- N RJ45 Ethernet port
- O ConvoVent mini condensation hood by Halton (RS232) - optional
- P mini Condensation Hood Pro - optional
- Q Used to reset the thermal cutout

mini 6.10 dimensions and connection points (right-hinged unit door)

Front view

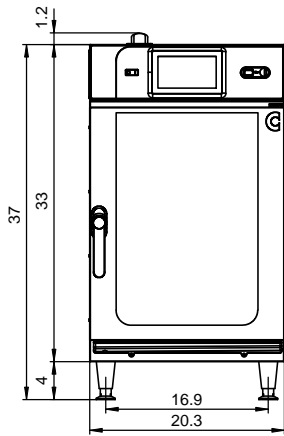

Side view

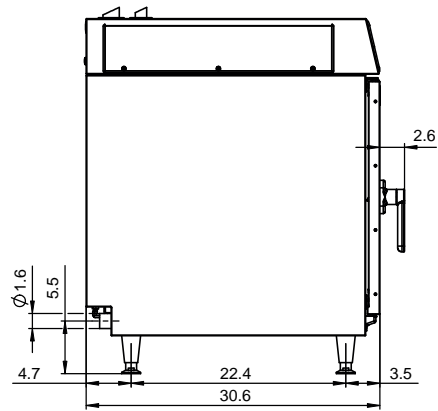

View from above with wall clearances

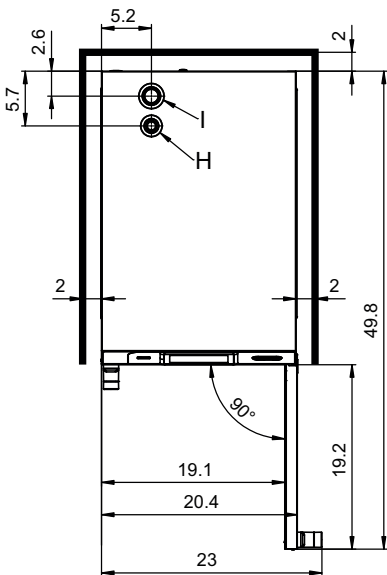

Connections at bottom of unit

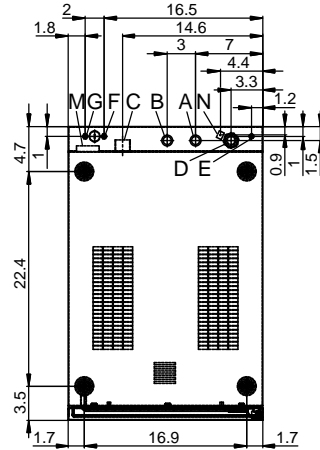

Rear view

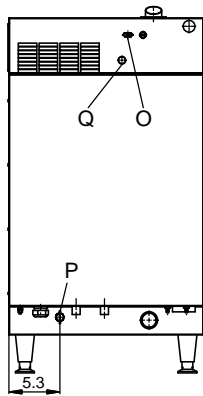

Key

- A Soft water connection, 3/4" GHT
 - B Cold water connection, 3/4" GHT
 - C Drain connection 1.5"
 - D Electrical connection
 - E Bonding
 - F Rinse-aid connection
 - G Cleaning-agent connection
 - H Air vent \varnothing 1.18"
 - I Ventilation port \varnothing 1.69"
 - M Safety overflow 2.36" x 0.79"
 - N RJ45 Ethernet port
 - O ConvoVent mini condensation hood by Halton (RS232) - optional
 - P Accessory CH Pro condensation hood - optional
 - Q Used to reset the thermal cutout
-

Combi Oven
Convotherm mini

OES mini 6.06, 6.10, 10.10

Serial No.

Item no.

Order No.

Additional technical documentation can be found in the download center at :
www.convotherm.com



Welbilt offers fully-integrated kitchen systems and our products are backed by KitchenCare® aftermarket parts and service. Welbilt's portfolio of award-winning brands includes **Cleveland™**, **Convotherm®**, **Crem®**, **Delfield®**, **fit-kitchenSM**, **Frymaster®**, **Garland®**, **Kolpak®**, **Lincoln™**, **Manitowoc®**, **Merco®**, **Merrychef®** and **Multiplex®**.

Bringing innovation to the table • welbilt.com