

MODEL EST66

INSTALLATION & OPERATION MANUAL

Rev.1.04A
08-22-19

CMA DISHMACHINES
12700 KNOTT STREET
GARDEN GROVE
CALIFORNIA 92841

800-854-6417
FAX 714-895-2141



Table of Contents

EST-66

1. SPECIFICATIONS.....	2
1.1. EST- 66.....	2
2. GETTING STARTED.....	3
2.1. Introduction to CMA Model EST -66.....	3
2.2. Receiving and Installation	4
2.2.1. <i>Box Item List</i>	4
2.2.2. <i>Electrical</i>	5
2.2.2.1. Control Box Components	6
2.2.3. <i>Plumbing</i>	7
2.2.4. <i>Scrap Tray Assembly Installation</i>	9
2.2.5. <i>Conveyor Drive/ Rack Speed</i>	10
2.2.6. <i>Wash Pump Assembly and Impeller</i>	11
2.2.7. <i>Table Limit Switch Installation</i>	12
2.2.8. <i>Optional Vent Hood Adapter's Installation</i>	13
2.2.9. <i>Chemical Dispenser Connection</i>	14
2.2.10. <i>Optional Exhaust Fan Control P/N 13578.00</i>	14
2.2.11. <i>(Optional) E-Temp Booster Heater</i>	15
2.3. EST-44 Safety Tips	16
3. OPERATION	17
3.1. Beginning Operation.....	17
3.2. Cleaning Instructions	19
3.3. Regular Service and Maintenance Checklist	20
3.4. Trouble Shooting	21
3.5. Drain Water Tempering Kit (Optional)	22
4. ELECTRICAL DIAGRAM FOR 240V, 3 PHASE EST-66	23
5. ELECTRICAL DIAGRAM FOR E-TEMP HEATER ONLY.....	24
6. ELECTRICAL DIAGRAM FOR 480V EST-66.....	25
7. ELECTRICAL DIAGRAM FOR 240V, 1 PHASE EST-66	26

1. Specifications

1.1. EST- 66		EST-66	EST-66	
		L.T.	H.T.	
WATER CONSUMPTION				
PER RACK (FINAL RINSE)		.46 GAL.	.46 GAL.	
PER HOUR (FINAL RINSE)		114 GAL.	114 GAL.	
CONVEYOR SPEED				
FEET PER MINUTE		6.75	6.75	
OPERATING CAPACITY				
RACKS PER HOUR (NSF rated)		249	249	
OPERATING TEMPERATURE				
WASH RECOMMENDED		140° - 150° F	150° - 160° F	
PUMPED RINSE RECOMMENDED		140° - 150° F	150° - 160° F	
FINAL RINSE RECOMMENDED		140° - 150° F	180° - 195° F	
WATER REQUIREMENTS				
INLET TEMPERATURE (MIN)		140° F	180° F	
WATER INLET SIZE			1/2"	
FINAL RINSE SIZE			1/2"	
DRAIN SIZE			2"	
FINAL RINSE PRESSURE			20 PSI	
HEATERS				
WASH HEATER		13.3 KW/240V(1 phase) 13KW/208V(3 phase)		
RINSE HEATER		3KW/240V, 2.25KW/208V		
MOTORS				
WASH PUMP (2)		1 HP		
RINSE PUMP		1/3 HP		
CONVEYOR		1/8 HP		
DIMENSIONS				
DEPTH		25-1/8"		
WIDTH		66"		
HEIGHT		55 -1/2"-56-1/2"		
STANDARD TABLE HEIGHT		32 1/2" adjusts to 34"		
MAX CLEARANCE FOR DISHES		19"		
STRANDARD RACKS		19 3/4" x 19 3/4"		
ELECTRICAL RATING				
	VOLTS	PHASE	AMPS	AMPS(Tall)
	208	1	78	N/A
	240	1	87	N/A
	208	3	58	64
	240	3	66	72
	480	3	26	29
SHIPPING WEIGHT		810#	(367kg)	



2. Getting Started

2.1. Introduction to CMA Model EST -66

The **EST** is designed to give maximum cleaning in 44 inches. It represents the cleaning power of machines twice its length. The curtains incorporated in the dishwasher minimize the transfer of water from tank to tank during the wash and sanitizing procedures.

The energy costs for running the **new EST-66** have been greatly reduced, by the introduction of our **new Stage Washing Process**. The EST-66 Conveyor dishwasher (*EST is abbreviation for ENERGY STAR*) lowers gallon/rack ratings and is directly related to CMA's **new Power-Rinse Stage** that has been introduced. The EST-66 **new Re-circulating Wash** and **new Power-Rinse Stage** greatly reduce the amount of chemicals being used, thus adding a significant cost reduction and energy efficiency to its' operation.

The EST-66 can be used as a high or low temperature dishwasher, with the new wash tank and power rinse tank designs, both having their own re-circulating pumps. The Power Rinse Stage provides a fresh cleansing rinse, before the dish rack advances into the *Power Rinse and Fresh Water* and Sanitizing Rinse Stages.

The initial-fill water and the final rinse water that is supplied to the EST-66 must be a minimum of 140°F, in low-temperature applications, while high-temperature machines will require two water lines; one at a minimum water temperature of 140°F to fill the dishwasher, and the second with a minimum of 180°F for the final rinse. With the introduction of the **new optional E-Temp Booster Heater**, it will be offered fully integrated to the dishwasher.

The EST-66 also features a stainless steel scrap accumulator tank and tray, which must be emptied on a periodic basis, as necessary. The EST machine is designed to deliver 0.49 gallons of fresh rinse water for each rack. This water flows from the rinse and power-rinse tanks into the wash tank, and then overflows into the scrap tray, carrying any debris that may have fallen into the wash tank, thereby providing a much cleaner environment for the washed and rinsed dishes. If preferred, there are also options such as a Corner Feed System, optional Vent Hood Adapters, Exhaust Fan Control Circuits and a Drain Tempering Kit. CMA also offers a full line of other machine accessories, including stainless steel dishtables. (See equipment catalog)

DISCLAIMERS

CMA expressly disclaims any and all warranties, express or implied, relating to the installation of any and all CMA equipment that is installed by chemical dealers, contracted servicers or third party servicers to CMA equipment. If the installation instructions are not followed exactly (to the letter), or, if any person or company conducting the installation of the CMA equipment, revise the installation procedures or alter the instructions in any manner, the CMA warranty becomes void. If, due to the improper installation of CMA equipment, this equipment ceases to operate properly or affects other parts of the CMA dishwashing equipment, in that the other parts become defective, the CMA warranty becomes void. CMA will not be liable or responsible or warrant CMA equipment, due to improper installation of any CMA model dishwasher.

CMA does **NOT** endorse "Tankless On-Demand" water heaters for use on CMA Dishmachine products. On most applications, the volume of hot water required for commercial dishmachines exceeds the capacity of these types of heating sources. You will find that most, if not all, commercial dishmachines have been programmed with auto-filling features that require quick filling, with a designated limited time.

CMA **DOES** endorse, and highly recommends, the standard "tank" style water heaters, sized properly to handle each particular facility with their water heating requirements. A "tank" style water heater stores and supplies a large capacity of preheated water before providing hot water to the dishmachine. To meet required health codes, there must be a reliable and consistent flow of adequate hot water supplied to the dishmachine. If the facilities' "tank" style water heater is marginal in size, CMA recommends installing a proper size Hatco Booster Heater, a CMA's E-Temp 40 or 70-degree-rise Booster Heater (that can be installed on CMA Conveyors), or a CMA Temp-Sure Booster Heater (for door and undercounter dishmachines). All are designed to adequately achieve results.

Important: Make sure incoming power supply corresponds to the voltage listed on the data plate. If the voltage is too low (206V or less), the heating elements will not reach desired temperature specified by manufacturer, and performance will be compromised. The heating element needs to be sized according to the facilities available voltage, which must be noted on your purchase order to CMA for a special dishmachine. Special lower voltage higher kilowatt heaters are available upon request.

Make sure a fused disconnect switch or circuit breaker (not supplied) is installed in the electrical service lines supplying this dishwasher and should meet the requirements of your local electrical code.

Warning: cancer and reproductive harm – www.P65Warnings.ca.gov

2.2. Receiving and Installation

2.2.1. Box Item List

When you receive your new EST-66, prior to installation of the dishwasher, remove the box containing the all items needed for the installation. (See item list below)

- Literature & Manuals
- Instructional Operation Video
- Scrap Tank Assembly, w/Mounting Bracket
- Curtains Interior and Exterior, w/Rods
- Exterior Wrapper Shields
- Installation Hardware
- Operation Wall Chart
- Optional Vent Hood Adapters when ordered.

Start by first installing the Scrap Tray Assembly (see **Scrap Tray Assembly, Section 2.2.4**), along with the Overflow Chute, then the two wrapper shields and the exterior and interior curtains and rods, which are shipped inside the machine. All of the wash-arms are fully installed over the wash and power-rinse tanks. There are a total of three curtains used in the EST-66: two long-exterior curtains and one short-interior curtain, all with their own curtain rods. (See Figure 2.2-1, below)

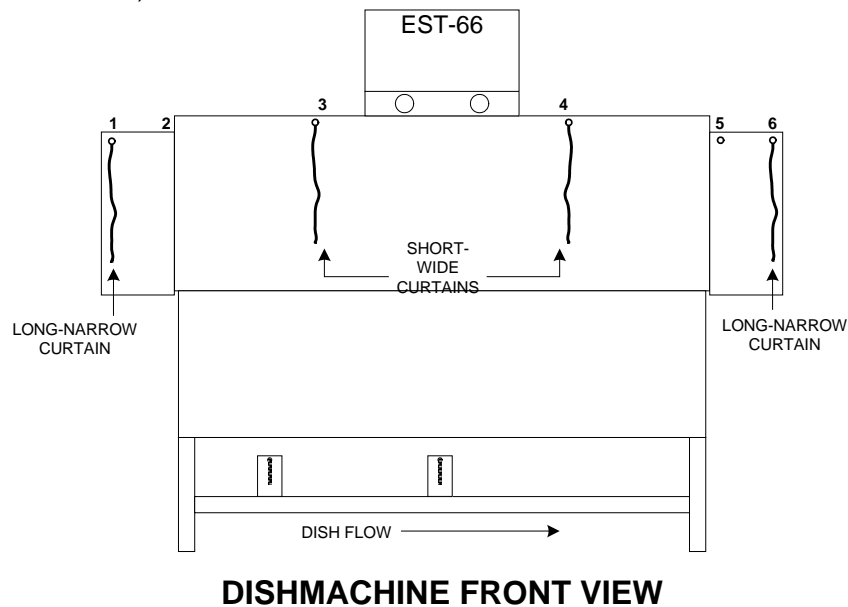

Figure 2.2.1

2.2.2. Electrical*

The CMA Model EST-66 Conveyor can be ordered as Single-Phase or Three-Phase, using 208v to 240v. The machine **must** be connected to a dedicated circuit. (See Figure 2.2.2 below for amp draw). When installing a Three-Phase machine, check the voltage on all three incoming lines, and place the highest leg on the **L2** terminal. (This is called a high-leg, stinger-leg, or Wild-leg.)

Prior to installation make sure the electrical supply is compatible with the specifications on the machines data plate.

WARNING: Electrical and grounding connections must comply with the applicable portions of the National Electrical Code and/or other local electrical codes.

Note: For supply connections, use copper wire only rated at 90 degree C minimum.

Warning: To prevent excessive overloads and component damages, it is essential for the Dispenser Power Supply to be wired to the supplied Power Block on all conveyors. The CMA-supplied power block has been pre-wired to the wash heater contactor L1 and L3 terminals, to assure a correctly balanced power, as well as accurate surrounding components.

Only for dispensers requiring constant power, connect to **L1** and **L3** of main contactor; otherwise, use the Dispenser Power Block that has been provided.

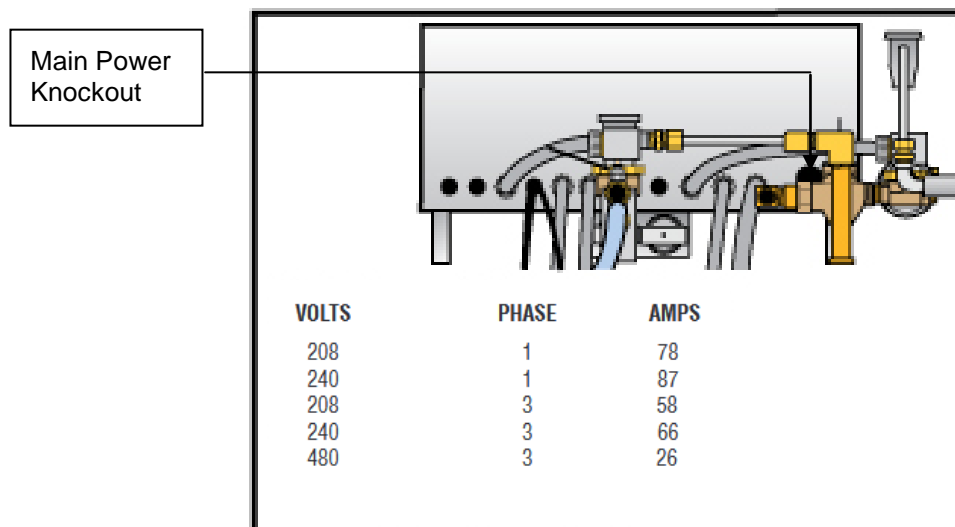

Figure 2.2.2

On a 3-phase machine the water pump motors are also 3-phase and, depending on the terminal that each phase is connected to, the motor can rotate in either direction. Check the direction of rotation by removing the dust cap on the back of the motor. The motors must turn clockwise, when looking at the shaft from the back of each motor. To change the direction of rotation, switch any two power lead wires at the motor.

DANGER: ALWAYS TURN OFF THE DISHWASHER'S MAIN POWER SUPPLY BEFORE SERVICING THE DISHWASHER. ALTHOUGH THE MACHINE'S MAIN POWER SWITCH IS "OFF", THE MAIN CONTACTOR LEADS WILL STILL HOLD VOLTAGE.

* Electrical and plumbing connections must be made by a qualified person who will comply with all available Federal, State, and Local Health, Electrical, Plumbing and Safety codes

2.2.2.1. Control Box Components

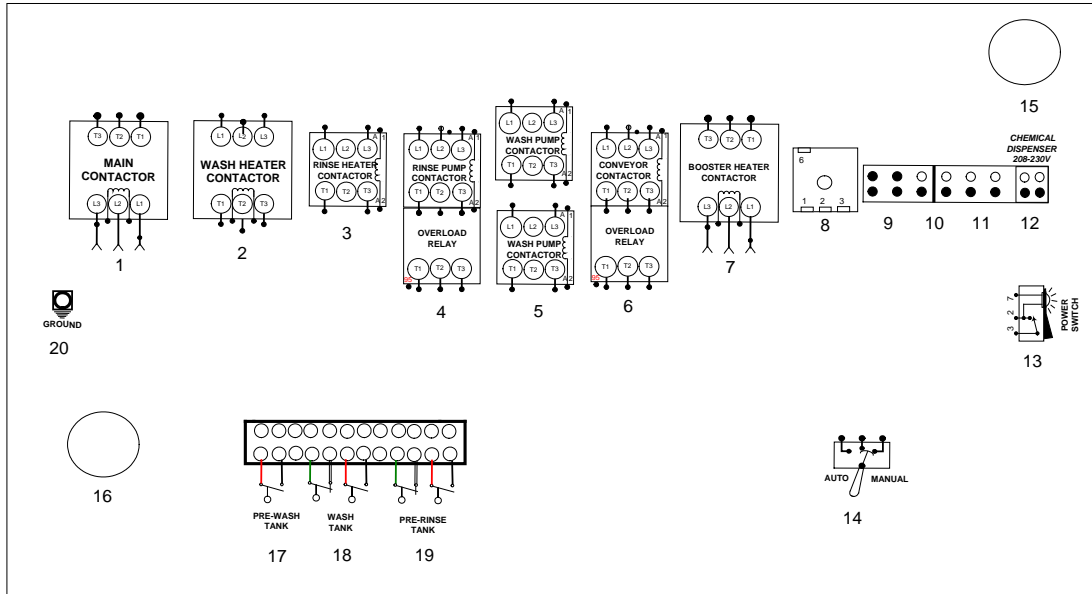

- | | |
|---|--------------------------------------|
| 1. Main Contactor | 11. Detergent Terminals |
| 2. Wash Tank Heater Contactor | 12. Dispenser Power Supply Terminals |
| 3. Power Rinse Heater Contactor | 13. On-Off Power Switch |
| 4. Power Rinse Motor Contactor w/overload | 14. Auto/Manual Switch |
| 5. Wash Pump Contactors | 15. E-Temp Power Cable Knockout |
| 6. Conveyor Contactor w/overload | 16. Main Power Knockout |
| 7. E-Temp Heater Contactor (Optional) | 17. Pre-Wash Tank Float Terminals |
| 8. Conveyor Timer | 18. Wash Tank Float Terminals |
| 9. Table Limit Switch Terminals | 19. Power Rise Float Terminals |
| 10. Sanitizer/Rinse Terminal Terminals | 20. Ground Terminal |

2.2.3. Plumbing*

Note: The required flowing water pressure to the dishwasher is 15-65 PSIG. If pressures higher than 65 PSIG are present, a pressure regulating valve must be installed in the water line to the dishwasher (by others). If flowing pressure is lower than 15 psi, improper machine operation may result.

Notice to Plumber: The plumber connecting this machine is responsible for making certain that the water lines are THOROUGHLY FLUSHED OUT BEFORE connecting to the dishwasher.

CMA recommends utilizing a water softening system to maintain water hardness measurements of 3.5 gpg (grains per gallon) or less. This will assure maximum results and optimum operation of the dishmachine.

Note: high iron levels in the water supply can cause staining and may require an iron filter. High chlorine levels in the water supply can cause pitting and may require a chloride removal system. If an inspection of the dishwasher or booster heater reveals lime buildup after the equipment has been in service, water treatment is recommended. If water softener is already in place, ensure there is a sufficient level of salt.

The water supply connection is made with two ½" hot water lines; the valves are located at the top of the machine, behind the main control box. The water supplied to the machine must be a minimum of 140° F to the main fill valve and a minimum of 180° F to 195° F for a high temperature final rinse, with no more than 140° F for a lower temperature final rinse. (See Figure 2.2.3a below)

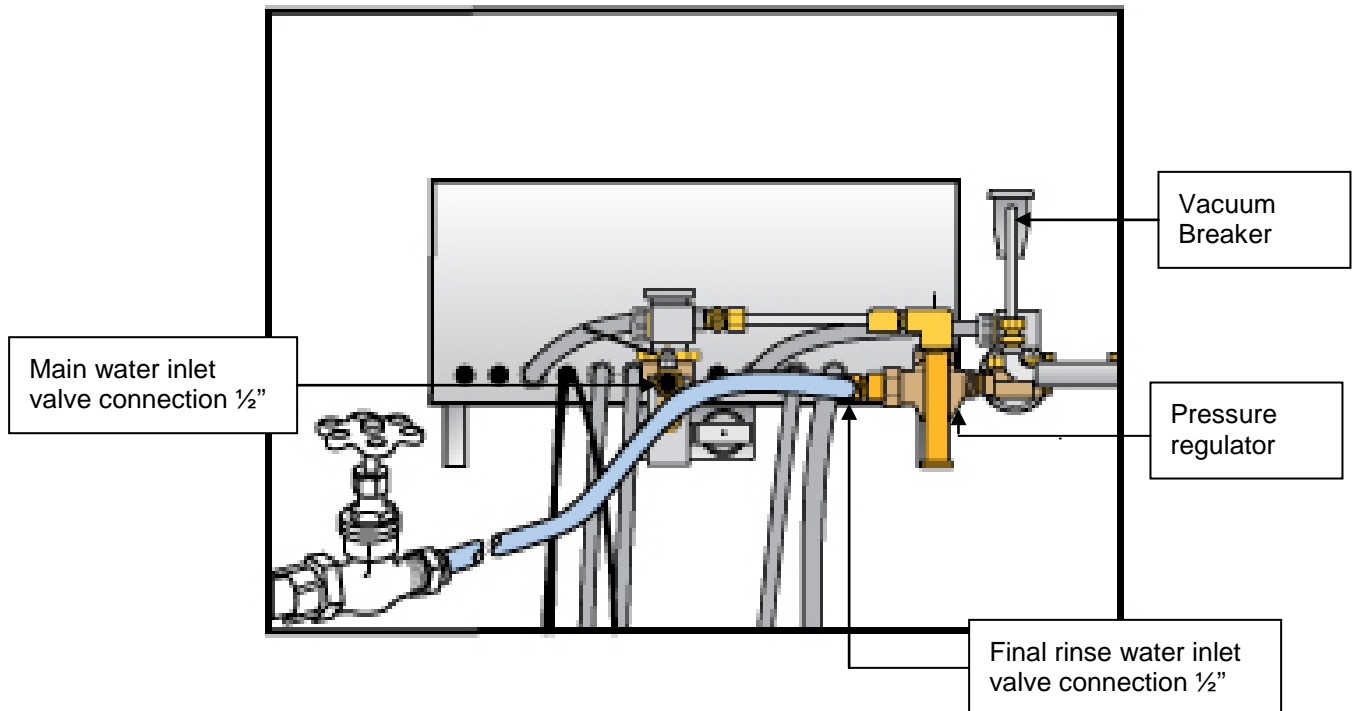

Figure 2.2.3a

To set the final rinse pressure, the final rinse must be running. Turn the adjustment screw clockwise to increase final rinse pressure; and counter-clockwise to decrease the pressure set the final rinse pressure to 20-psi ±5 psi. (Set to 22 - 23 psi for optimum running pressure)

* Electrical and plumbing connections must be made by a qualified person who will comply with all available Federal, State, and Local Health, Electrical, Plumbing and Safety codes

There are two 2" drain openings off both ends of the dishwasher, however only one connection is on the horizontal drainpipe. Place the 2" drain plug, supplied in the end of the pipe not being connected to the drain line (See Figure 2.2.3.b below).

Note: One of the ends of the horizontal drainpipe has a stopper cap on it – simply move the cap to the other end, if it's currently on the end needed for the drain connection.

*The Scrap Tray Assembly is placed inside the machine for shipping. Follow the instructions provided in **2.2.4 Scrap Tray Assembly** to properly install to the dishmachine.*

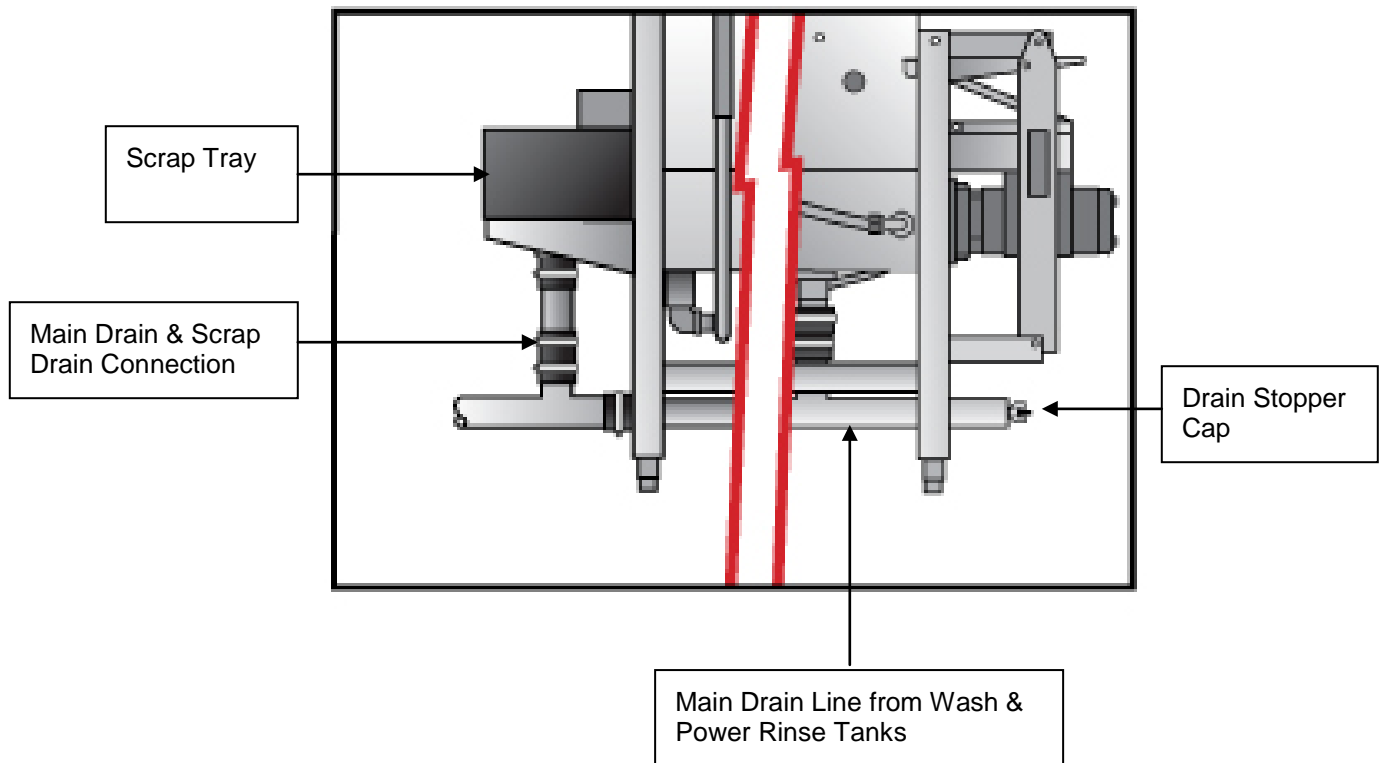

Figure 2.2.3b

2.2.4. Scrap Tray Assembly Installation

The Scrap Tray Assembly and Overflow Chute, which were shipped inside the machine, can easily be installed by executing the following steps: **Figure 2.2.4** below illustrates the assembly, as it would appear for a Left-to-Right machine – (a Right-to-Left machine would simply be the mirror image).

Caution:

1. For proper spacing, the SS flat washer must *not* be located between the head of the truss head bolt and the inside of the machine.
2. The illustration below shows the correct placements of the scrap trap holder. Do not install upside down, otherwise water deflection takes place.

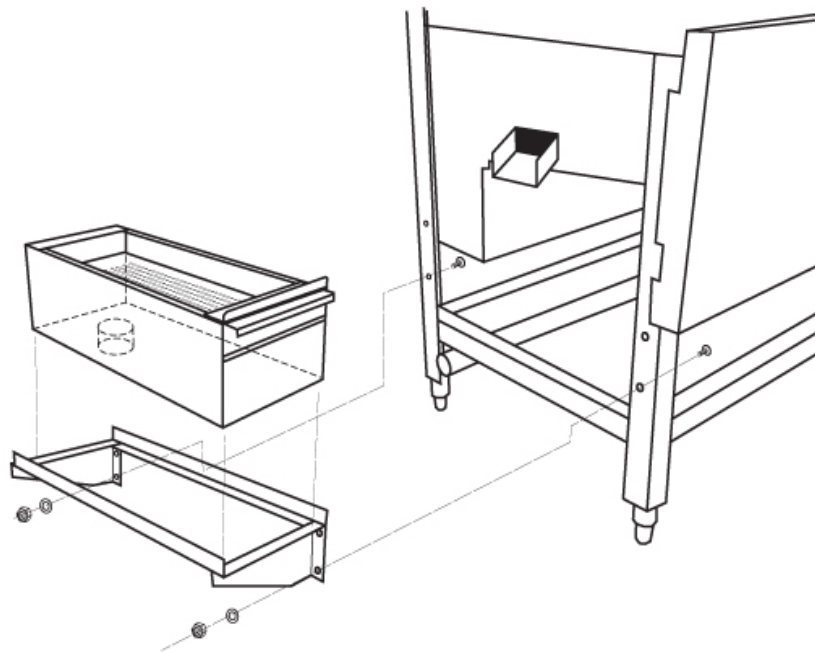

Figure 2.2.4

1. Remove items from their packaging and verify that all “installation hardware” was included.
2. Secure the scrap trap holder to the dishmachine by using the four ¼-20 X ½” Hex Head Bolts, the ¼” SS Flat Washers, and the ¼”-20 Nylon Lock Nuts that were provided.
3. Set the scrap trap body—with the scrap trap drawer inserted—into position on the scrap trap holder. (Attach the drain as specified in Section 2.2.3)

2.2.5. Conveyor Drive/ Rack Speed

The Conveyor Drive Cam below shows the two different conveyor drive cam speed settings; for standard 243 Racks/Hour and a slower 205 Racks/Hour (See Figure 2.2.5). By changing the Drive Cam Bearing location, the racks will travel through the machine slower.

Note: If the dishwasher is being used in a very heavy soil environment, changing the rack speed to 205 racks/hour will slow down the racks as they pass-through the dishwasher, allowing them to receive more chemical and water “contact time”.

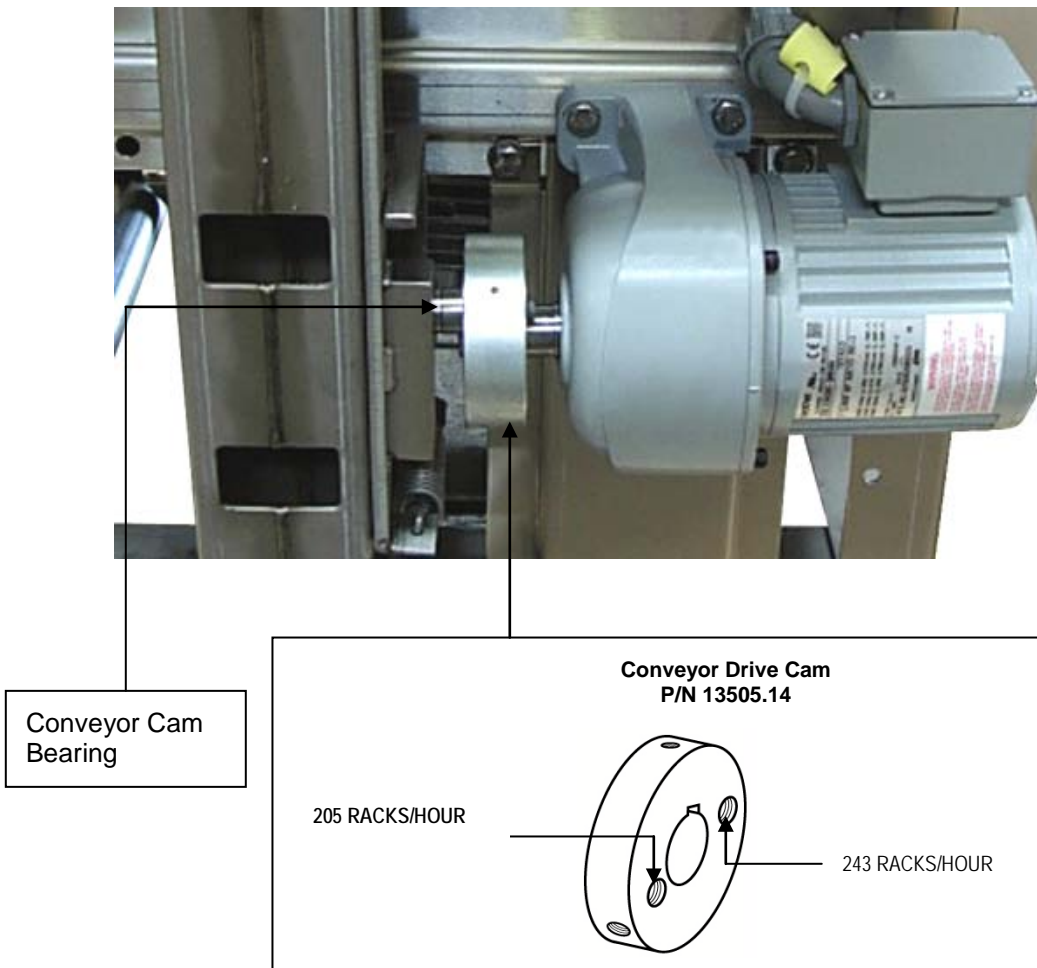

Figure 2.2.5

Caution: DO NOT GET IN THE PATH OF THE CONVEYER DRIVE ASSEMBLY, ROCKER ARM, OR CONVEYOR BAR, WHILE MACHINE IS IN OPERATION. DO NOT REACH INTO THE ROCKER ARM ASSEMBLY WITHOUT FIRST MAKING SURE THE DISHWASHER IS TURNED “OFF” AT THE MAIN PANEL. EVEN WITH THE MACHINE’S POWER SWITCH “OFF”, THE MAIN CONTACTOR LEADS WILL STILL CARRY VOLTAGE.

2.2.6. Wash Pump Assembly and Impeller

The standard wash pump motor is three-phase and can operate clockwise, as well as counter-clockwise; the **Nylon Lock Nut** used to hold the impeller in place (See Figure 2.2.6), is very important. When servicing the Wash Pump Assembly and replacing the seals, make sure it is secured properly; otherwise, if the motor turns the wrong direction, the impeller may spin-off the motor shaft causing damage to the impeller.

Note: ALWAYS CHECK THAT THE DIRECTION OF THE MOTOR ROTATION IS CLOCKWISE, WHEN REINSTALLING THE WASH PUMP. IF THE MOTOR IS TURNING COUNTER-CLOCKWISE, EXCHANGE L1 AND L3 WIRES ON MAIN CONTACTOR

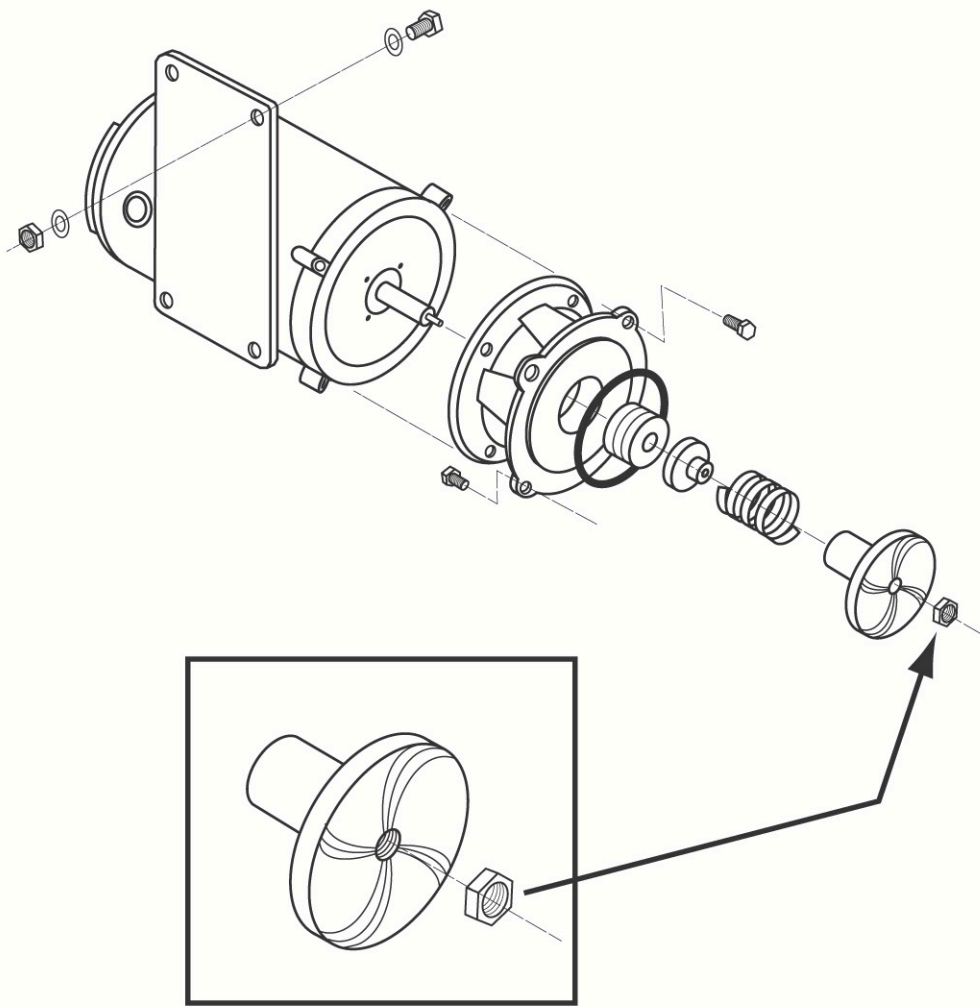

Figure 2.2.6

Note: The **Nylon Lock Nut** indicated by the arrow in **Figure 2.2.6** must be removed before attempting to remove the water pump impeller.

2.2.7. Table Limit Switch Installation

The Model EST-66 is shipped with a Table Limit Switch fully wired and connected in the main control box, ready to be installed on the clean side of the dishtable. The Table Limit Switch **MUST** be installed to prevent dishrack and Conveyor Drive damage.

1. Remove the template that was shipped to hold the table-limit switch assembly together.
2. Remove the activator bar (Figure 2.2.7a).
3. Position the template in the middle of the clean side of the dishtable.
4. Mark the end of the table, where the holes need to be drilled (Figure 2.2.7b).
5. Drill the holes.
6. Attach the Table Limit Switch, using the hardware supplied.
7. Reattach the activator bar removed earlier.
8. Test that it functions properly (Figure 2.2.7c).

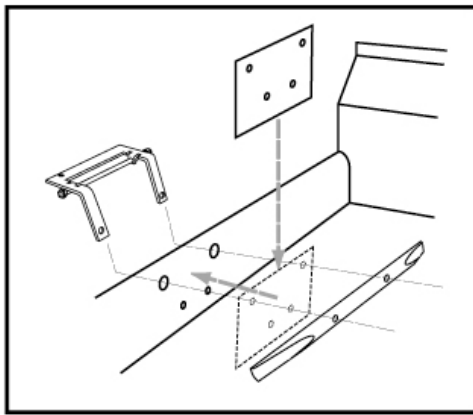

Figure 2.2.7a

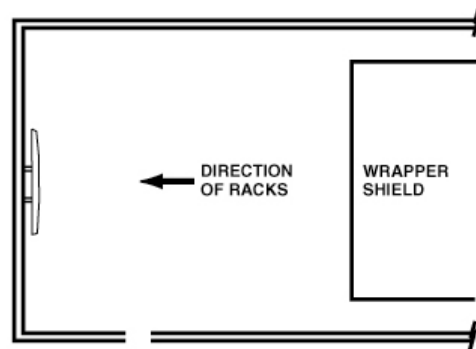

Figure 2.2.7b

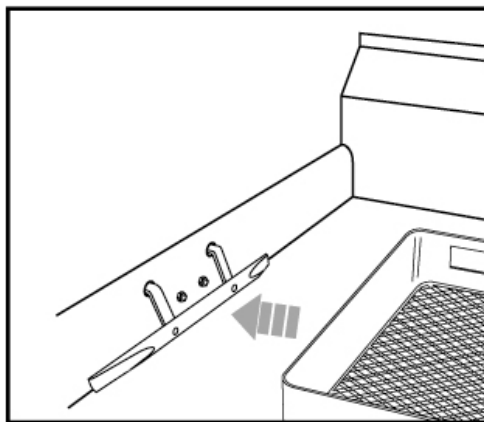
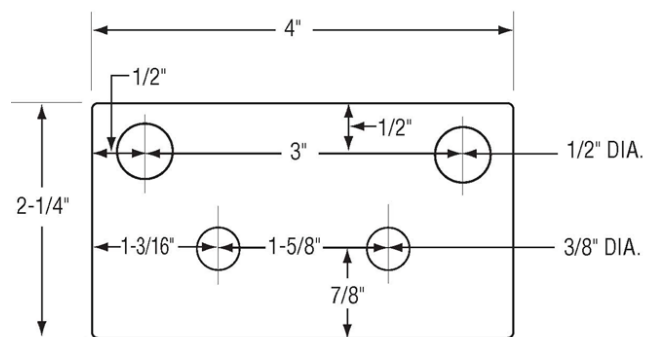

Figure 2.2.7c



Note: This terminal is not actual size, not to be used for installation!

2.2.8. Optional Vent Hood Adapter's Installation

CMA Vent Hood Adapters have been designed and engineered to draw *only* the steam that is released from underneath the curtains at the entrance and exit of the EST-66 conveyor dishwasher. This will allow the dishwasher to retain the heat within the machine, reducing the energy consumption of the dishwasher. To maintain proper CFM's (600), and not evacuate the heat from the dishwasher tanks, CMA Vent Hood Adapters (PN # 13901.82) **MUST be used**.

Note: ON ALL PANT-LEG-STYLE VENT SYSTEMS, BY MODIFYING OR INSTALLING AN UNAUTHORIZED BRAND OF VENT HOOD ADAPTER, IT WILL VOID THE CMA MANUFACTURERS' WARRANTY.

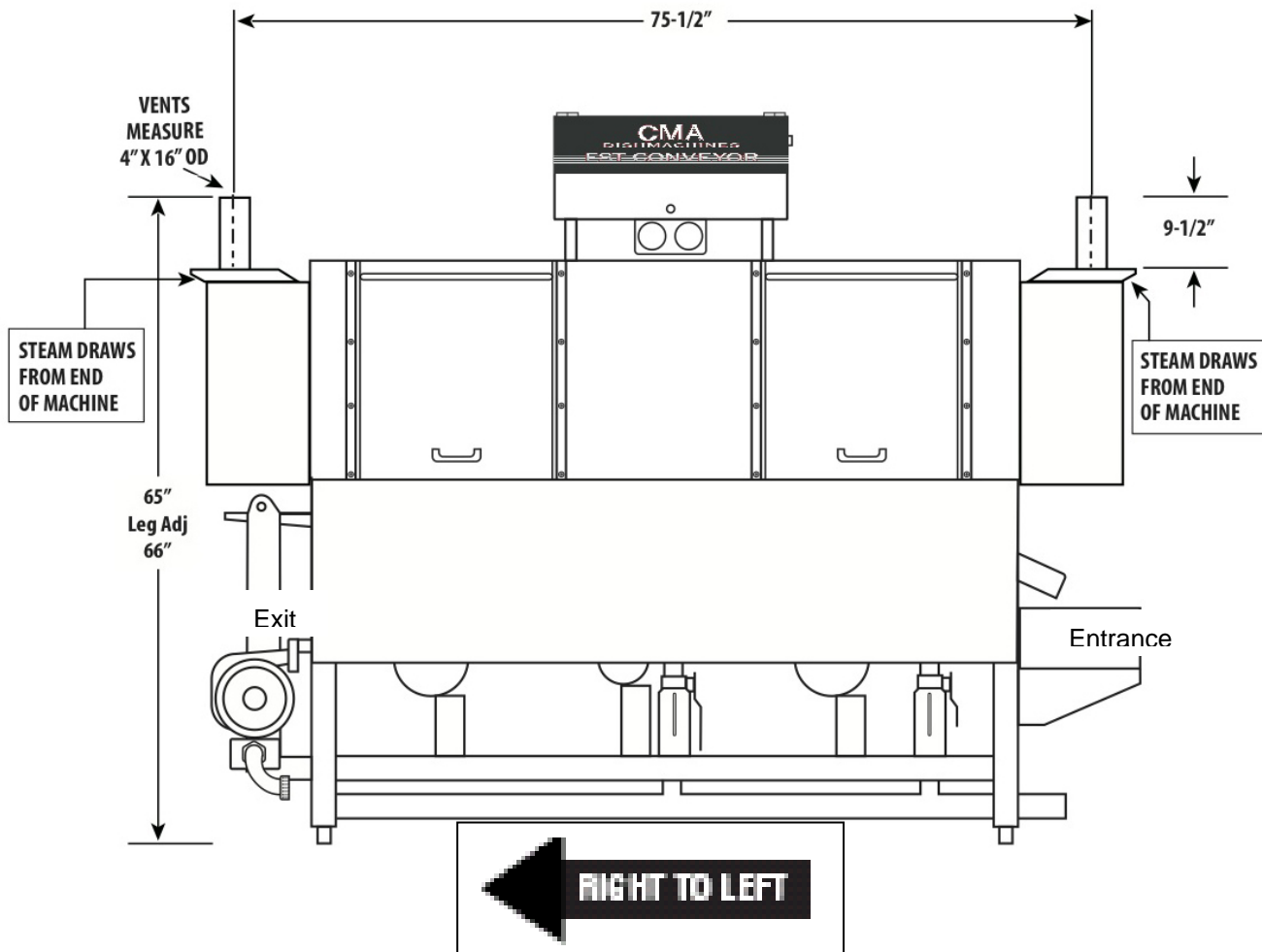

Adjusting the internal baffles of the Vent Hood Adapters:

Once the vent hood adapters have been installed, completely close the internal baffle using two 7/16" wrenches. Run the dishwasher to create heavy steam buildup; start at the exit end of the dishwasher, open the baffle enough to draw the steam into the vent system. Then repeat the same process on the entrance side of the dishwasher.

Note: ONLY ONE OF THE TWO NUTS ON EACH BAFFLE IS USED TO TIGHTEN AND KEEP THE INTERNAL BAFFLE FROM BEING REPOSITIONED.

2.2.9. Chemical Dispenser Connection*

The Model EST-66 will supply both the main power and the signals for the Detergent and Sanitizer/Rinse Aid. Connect the chemical dispenser main power leads, to the supplied power terminals. (See Figure 2.2.9)

Connect the Detergent and Rinse Aid signal wires to the supplied signal terminals (See Figure 2.2.9)

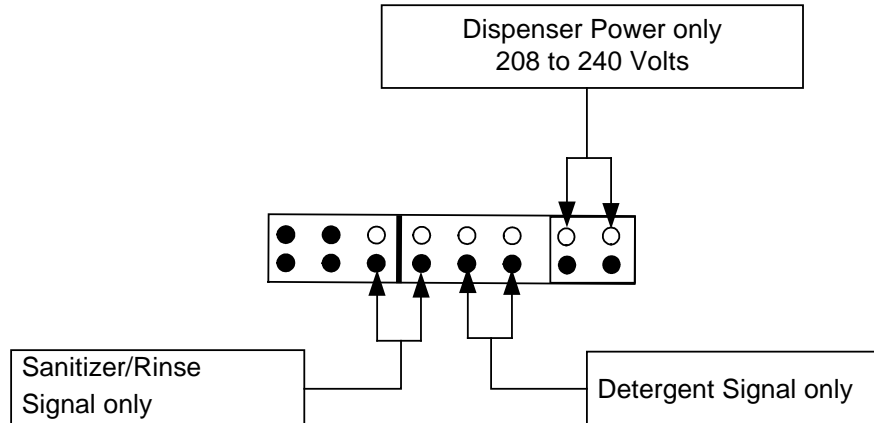

Figure 2.2.9

Note: Sanitizer/Rinse and Detergent signals can draw more than 0.5 Amps.

Note: Use only commercial-grade detergents and rinse aids recommended by your chemical professional. Do not use detergents and rinse aids formulated for residential dishwashers.

Low Temperatures chemical-sanitizing dishmachines must not exceed 6% sodium hypochlorite solution (bleach) as the sanitizing agent. Higher levels may damage stainless or components. Follow the directions precisely that are on the litmus paper vial and test the water on the surface of the bottom of the glasses.

2.2.10. Optional Exhaust Fan Control P/N 13578.00

First, when field-installing the Optional Exhaust Fan Control, locate the detergent signal terminals on the dispenser terminal block; mount the contactor, that was supplied with the kit, securely to the control box; connect the Blue and Yellow wires, also supplied in the kit, to the rinse signal terminals; attach the power for the exhaust fans to the L1 and L2 incoming terminals of the contactor, and the T1 and T2 terminals, to the exhaust fan.

Note: Wires for exhaust fan to be supplied by electrician. (See Figure 2.2.10)

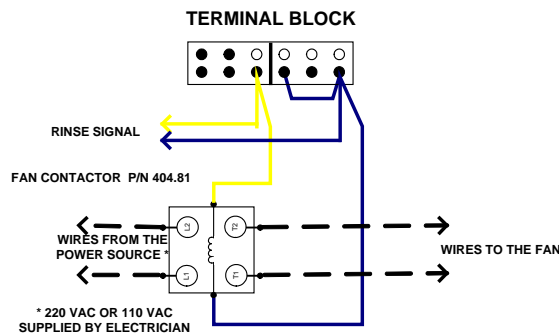

Figure 2.2.10

* Electrical and plumbing connections must be made by a qualified person who will comply with all available Federal, State, and Local Health, Electrical, Plumbing and Safety codes

2.2.11. (Optional) E-Temp Booster Heater*

The Optional E-Temp Booster Heater can only be ordered with a dishwasher, already installed at the factory; it **cannot** be installed in the field. The E-Temp Booster heater will be fully integrated into the EST-66 conveyors' plumbing system. It will require its' own power supply of 208 volts to 240 volts, in single-phase or three-phase. The unit can be specially ordered as a 480-volt unit, in three-phase only; temperature is available in a 40° rise or 70° rise. The E-Temp Booster heater contactor is located in the EST-44 Main Control Box (See item 7, page 6).

Note: E-Temp heater is shipped on the machine empty to prevent freezing. When machine is powered up for the first time, the booster heater must be filled by pressing and holding rinse switch to prevent heater damage.

Note: 70° degree rise E-temp Booster Heater is only available in Three-Phase.



AVAILABLE HOT WATER HEATER TANK CAPACITY	119 GPH 3.9 GAL	(450 LPH) 40
9kW @ 208V, 12kW @ 40°F RISE BOOSTER HEATER (ONE HEATING ELEMENT) OR 12kW @ 480V 40° RISE		
MIN. INCOMING WATER TEMP. RISE	140°F(60°C) 40°F	(22°C)
ELECTRICAL RATING	VOLTS	PHASE AMPS
	208	1 43
	240	1 50
	208	3 25
	240	3 29
	480	3 15

15kW @ 208V, 20kW @ 240V, 70°F RISE BOOSTER HEATER (TWO HEATING ELEMENTS) OR 18kW @ 480V 70° RISE			
MIN. INCOMING WATER TEMP.	110°F	(43° C)	
TEMP RISE	70° F	(39° C)	
ELECTRICAL RATING*	VOLTS	PHASE	AMPS
	208	3	42
	240	3	48
	480	3	22
*THE TWO ELEMENTS, 70°F RISE WILL BE AVAILABLE IN 3 PHASE ONLY.			

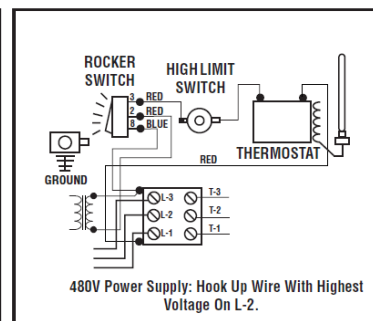
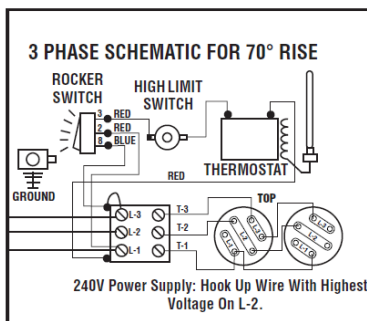
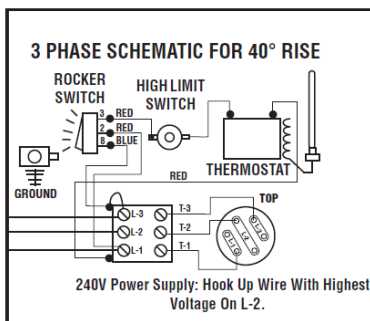

* Electrical and plumbing connections must be made by a qualified person who will comply with all available Federal, State, and Local Health, Electrical, Plumbing and Safety codes

2.3. EST-44 Safety Tips

- DANGER:** Always turn off the **main** circuit breaker at the wall when installing or servicing this dishmachine and/or an E-Temp Booster Heater. Even with the machine's power switch "off", there is a live connection being carried to the switch from the dishmachine contactor.
- CAUTION:** **Do not** get in the path of the Conveyor Rocker Arm or the conveyor's moving bar. **Do not** reach into the rocker arm area without first making sure the dishmachine is turned "off" at the circuit breaker.
- CAUTION:** **Do not** open the front door when the machine is in operation.
- CAUTION:** Avoid spraying water on or around the electrical control box located on the top of the machine. When cleaning, **do not** spray water directly on the motors.
- CAUTION:** When removing the Final Rinse Arms for cleaning, **exercise caution**. The Final Rinse Arms may be filled with chemicals or have additional pressure applied.

3. Operation

3.1. Beginning Operation

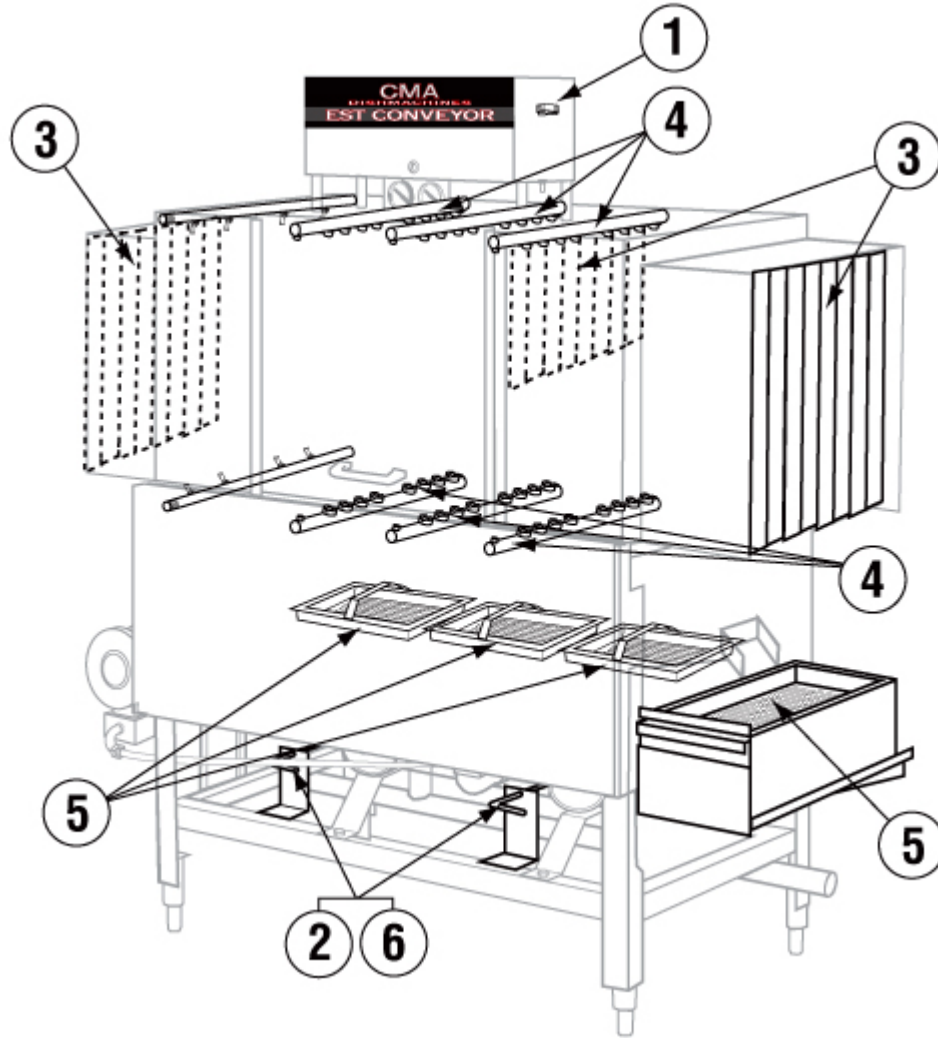
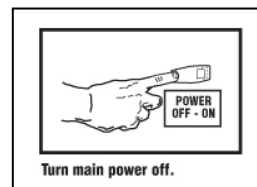
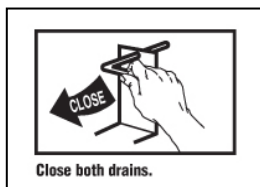

Figure 3.1

Step 1. Close both drains at the bottom of machine (see Fig.3.1 items 2,6 above)

Step 2. Turn on main power and machine will fill with water (see Fig.3.1 item 1 above)



Operation

Step 3. Allow machine to come to temperature

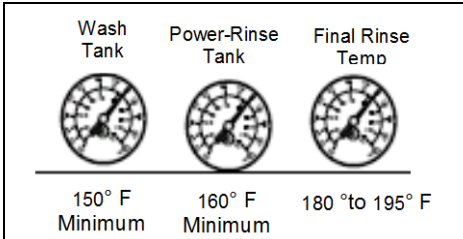

Step 4. Rinse rack thoroughly

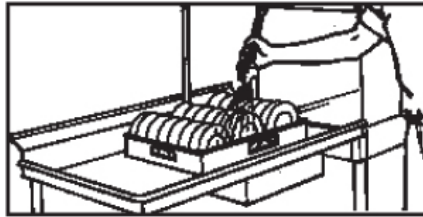

Step 5. Place rack in entrance

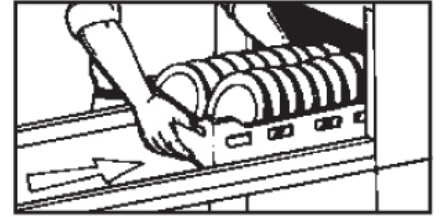

Step 6. Remove dishes from rack

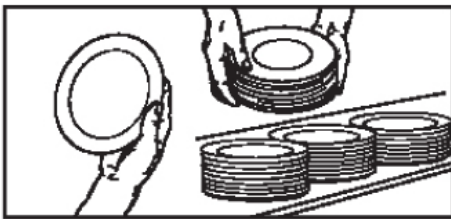

Step 7. Place properly in rack

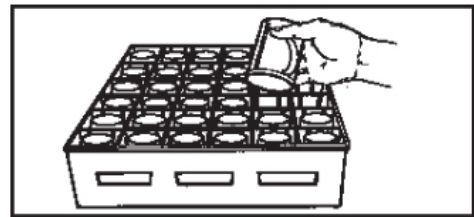

Step 8. Pre-soak flatware



Step 9. Wash flatware

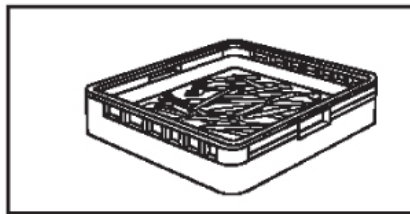

Step 10. Place flatware in containers with handles down; wash a second time

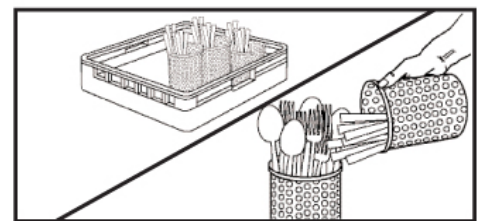

3.2. *Cleaning Instructions*



Drain dishmachine tanks.

See Fig.3.1, Items 2,6

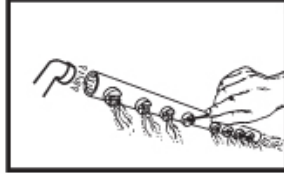

Inspect and clean wash arms.

See Fig.3.1, Items 4

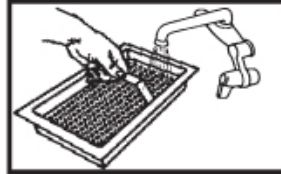

Remove and clean scrap trays and scrap drawer.

See Fig.3.1, Items 5

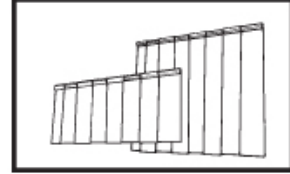

Remove, clean and re-install the curtains paying attention to location.

See Fig.3.1, Items 3

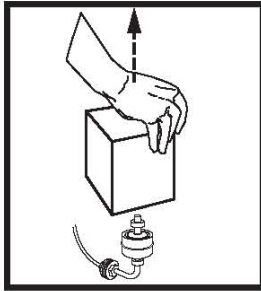

Remove cover, rinse and clean float switch.

3.3. Regular Service and Maintenance Checklist

- Check all electrical connections, assuring they are tight and secure.
- Check all Water, Drain, and Plumbing connections for leaks; tighten if needed.
- Check Final Rinse Arms: the Rinse Jet Spray should be straight up & down.
- Check Wash Pump motor rotation, making sure it is turning clockwise.
- Check Dish rack Movement, Conveyor Arm & Bar, and Conveyor Dog Alignment.
- Check Tray Track Guide and Rail & Table Alignment throughout dishwasher.
- Check Timer Dipswitch Setting; only switch 6 should be in "on" position (32 seconds)
- Check Wash-Tank Temperature 150° F Minimum.
- Check Power-Rinse Tank Temperature 160° F Minimum.
- Check Final-Rinse Temperature 180° to 195° F (High-Temp)
(140° F for Low Temp)
- Check Final Rinse Pressure 20 psi, ±5 psi
- Check Table-Limit Switch operation (If not installed, Warranty will be voided)
- Check Vent Hood adapter baffle position to draw steam. (Optional)
(Keep baffles open to a minimum)
- Check and make sure the dishwasher is level.
- Check to make sure all curtains are in place.
- Read all labeling and follow procedures.

Review installation section before beginning the installation of the Model EST-66 Conveyor Dishwasher. All installation procedures and guidelines **MUST BE** followed precisely.

3.4. Trouble Shooting

PROBLEM	LIKELY CAUSE	SOLUTION
Wash or power rinse motor not running	<i>Bad motor or capacitor</i> <i>Faulty contactor</i>	<i>Replace defective motor or</i> <i>Replace contactor</i>
Machine inoperative	<i>Fuse is burned out</i>	<i>Replace fuse</i>
	<i>Table limit switch</i>	<i>Remove dish rack at switch</i>
	<i>Defective door reed switch</i>	<i>Replace reed switch</i>
	<i>Defective start reed switch</i>	<i>Replace reed switch</i>
	<i>Defective auto/manual switch</i>	<i>Replace switch</i>
	<i>Defective Conveyor Timer</i>	<i>Replace timer</i>
Machine runs continuously	<i>Timer or settings@ 60 Sec</i>	<i>Replace timer or change settings</i>
	<i>Contactor stuck</i>	<i>Replace contactor</i>
Heater (no heat)	<i>Float switch</i>	<i>Check movement-replace it</i>
	<i>Defective thermostat or setting</i>	<i>Replace thermostat or adjust</i>
	<i>Defective heater contactor</i>	<i>Replace heater contactor</i>
	<i>Defective heater</i>	<i>Replace heater</i>
	<i>Wire connections</i>	<i>Check and correct</i>
Racks stuck	<i>Old or broken rack</i>	<i>Replace rack</i>
	<i>Tray track alignment</i>	<i>Adjust track to table properly</i>
Wash & Power rinse tank temperature low	<i>Incoming water supply</i> <i>(Low temp 120°F-Recommend 140°F;</i> <i>High temp 180°F minimum)</i>	<i>Check hot water supply</i>
	<i>Thermostat setting</i>	<i>Adjust thermostat to mach NSF label</i>
	<i>Vent hoods baffle setting</i>	<i>Set CMA Vent hood adapter baffles as instructed on page 13</i>
Low final rinse pressure or no rinse pressure	<i>Plugged rinse jets</i>	<i>Remove and clean</i>
	<i>Pressure regulator out of adjustment</i>	<i>Adjust pressure regulator 20psi to 23psi</i>
	<i>Water sol. valve coil or diaphragm</i>	<i>Replace or clean</i>
	<i>Dirty rinse jets</i>	<i>Remove and clean jets</i>
	<i>Defective rinse reed switch</i>	<i>Replace reed switch</i>
Machine using too much chemical	<i>Quick drain on wash end</i>	<i>Plumb quick drain back into wash tank</i>
	<i>Dispenser or settings</i>	<i>Check dispenser troubleshooting guide</i>
	<i>Rinse pressure</i>	<i>Set 20 psi.</i>
	<i>Soil</i>	<i>Check scrap basket sand float function</i>
Machine loosing water	<i>Quick drain on dirty side table</i>	<i>Check quick drain connections</i>
	<i>Sheet pans</i>	<i>Use CMA sheet pan rack</i>
	<i>Drain valves open</i>	<i>Close completely</i>
Low wash arm pressure	<i>Debris In wash & power rinse arm manifolds</i>	<i>Remove arm, check & clean debris from manifolds</i>
	<i>Clogged jets</i>	<i>Clean jets</i>
	<i>Motors connected wrong</i>	<i>Connect motors to reverse impeller direction</i>

3.5. Drain Water Tempering Kit (Optional)

**CMA-180, EST-44, EST-66
WATER TEMPERING VALVE KIT
P/N 13470.10**

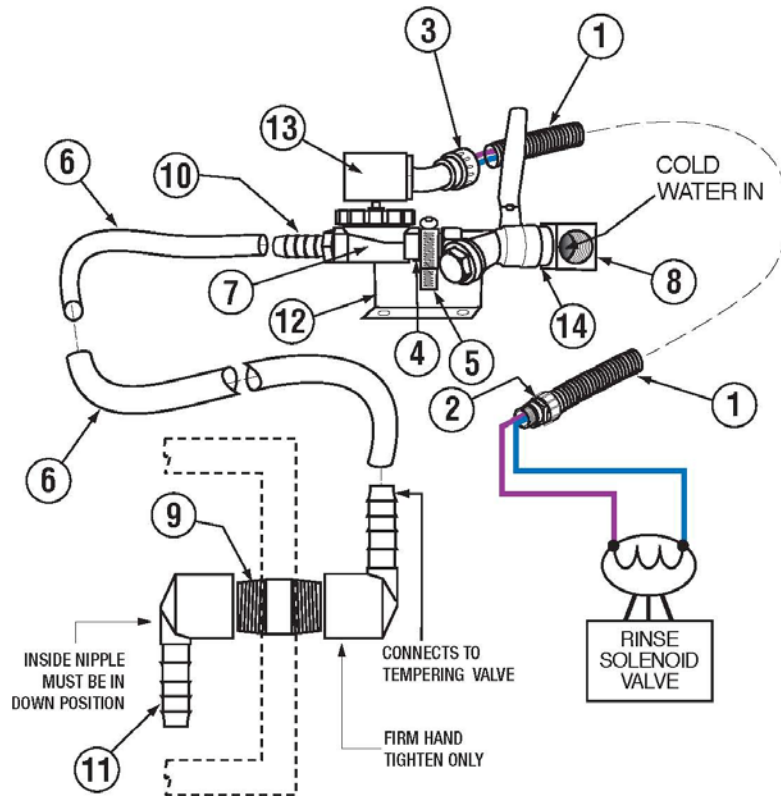

ITEM NO.	P/N	NO REQ'D	DESCRIPTION
1.	00400.00	2	CONDUIT 3/8" SEALTITE
2.	00401.00	1	ST-3/8" STRAIGHT CONNECTOR
3.	00402.00	1	ST-90 DEG 3/8" COONNECTOR
4.	00742.00	1	NIPPLE BRASS 1/2X1-1/2"
5.	03101.00	1	HOSE CLAMP #16 1"
6.	03106.45	5	BRAIDED HOSE 1/2"
7.	03603.15	1	WATER SOLENOID VALVE 1/2"
8.	41030.10	1	1/2" 90 DEG. ELL X F BRASS
9.	13472.00	1	NIPPLE PVC 1/2"X CLOSE
10.	13472.40	1	ADAPTER PVC 1/2" MALE X 1/2" BARB
11.	13472.50	2	ELBOW PVC 90 DEG F X BARB
12.	14508.50	1	PLUMBING BRACKET (180-UC)
13.	00738.15	1	SOLENOID VALVE COIL 220V
14.	41062.00	1	1/2" STRAINER BALL VALVE

2-2013

4. Electrical Diagram For 240V, 3 Phase EST-66

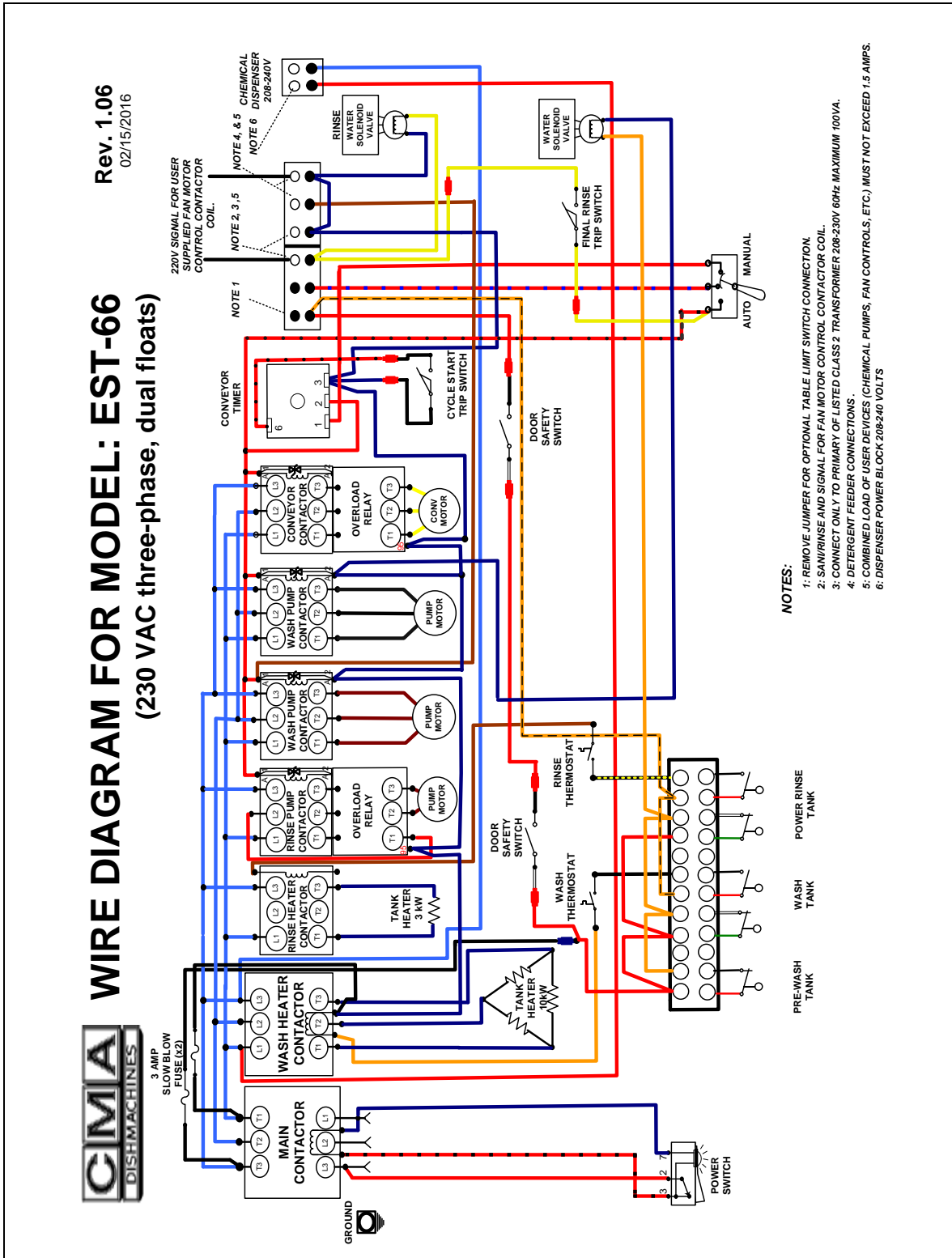

5. Electrical Diagram For E-Temp Heater Only

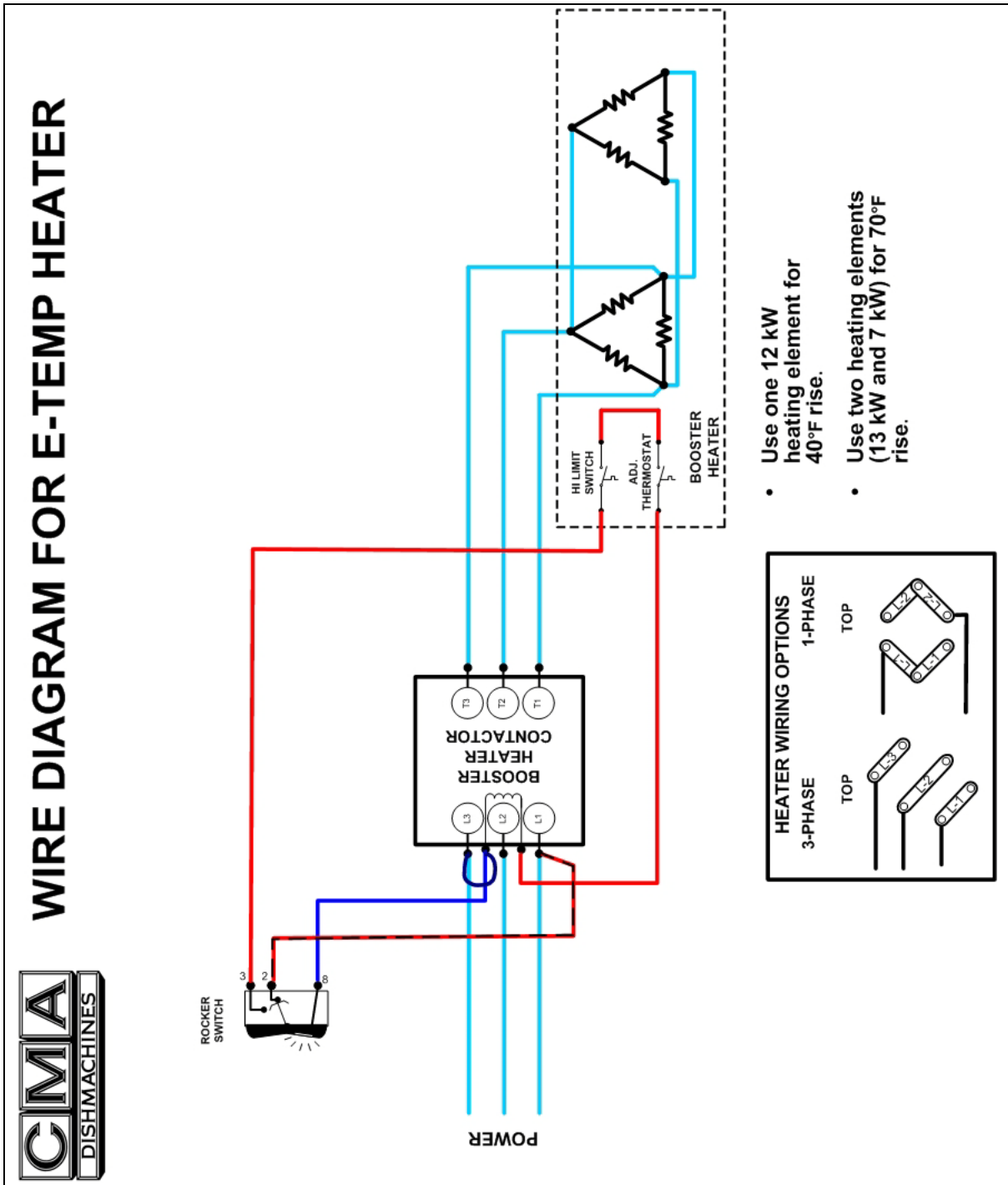

6. Electrical Diagram For 480V EST-66

WIRE DIAGRAM FOR MODEL: EST-66 w/TRANSFORMER: 480/575/600, DUAL FLOATS.



Rev. 1.02
02/15/2016

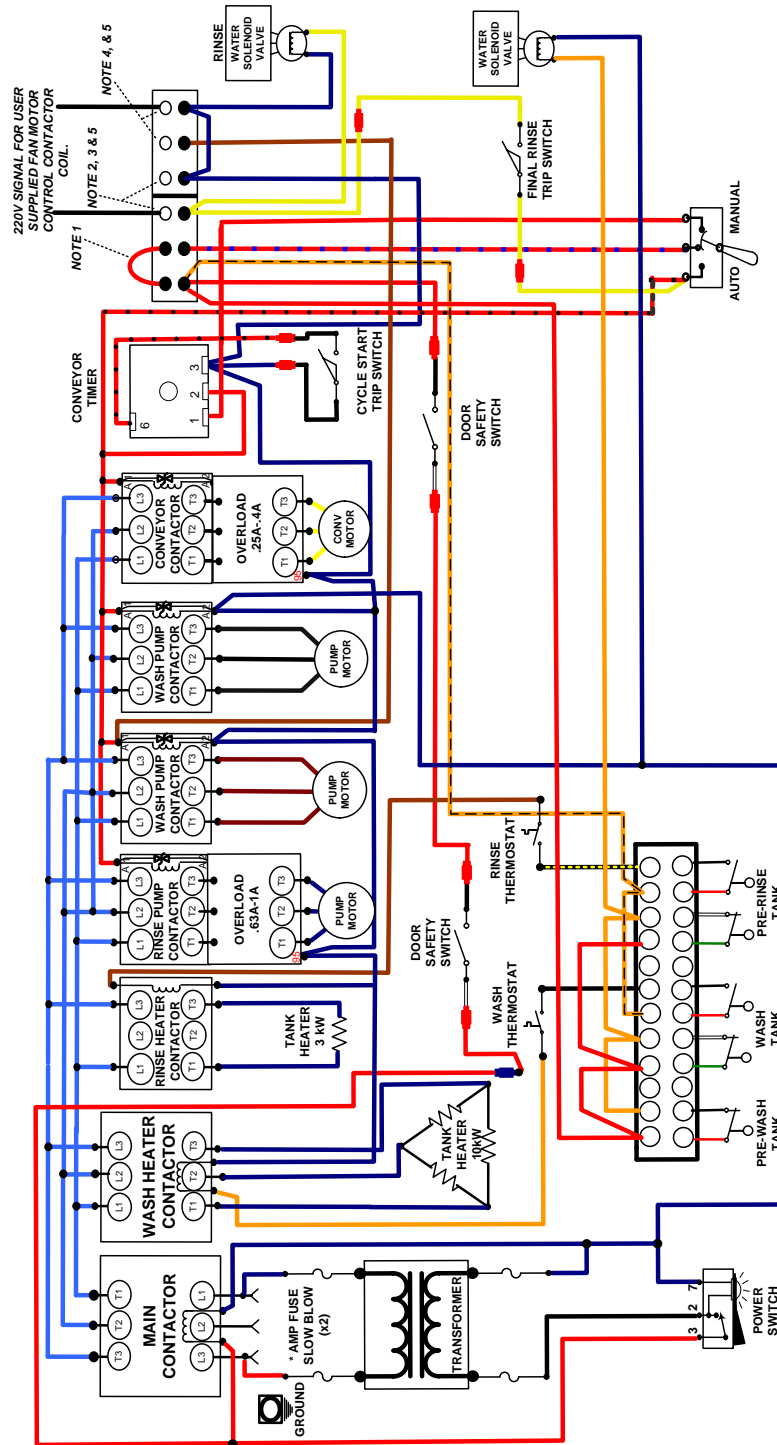

- NOTES:**
- 1: REMOVE JUMPER FOR OPTIONAL TABLE LIMIT SWITCH CONNECTION.
 - 2: SAN/RINSE AND SIGNAL FOR FAN MOTOR CONTROL CONTACTOR COIL.
 - 3: CONNECT ONLY TO PRIMARY OF LISTED CLASS 2 TRANSFORMER 208-230V 60Hz MAXIMUM 100VA.
 - 4: DETERGENT FEEDER CONNECTIONS.
 - 5: COMBINED LOAD OF USER DEVICES (CHEMICAL PUMPS, FAN CONTROLS, ETC.) MUST NOT EXCEED 1.5 AMPS.

- * 250 VA Transformer: 440 Volt application - 1.8 Amp
- * 480 Volt application - 1.5 Amp
- * 350 VA Transformer - 1.8 Amp

7. Electrical Diagram For 240V, 1 Phase EST-66

