



Owner's Manual

MODEL CMA-181GW

INSTALLATION & OPERATION

Rev 1.00C 12-08-2020



CMA GLASSWASHERS
12700 KNOTT AVENUE
GARDEN GROVE, CALIFORNIA 92841
800-854-6417

FAX 714-895-2141

www.cmadishmachines.com

TABLE OF CONTENTS

MODEL CMA-181GW

1. SPECIFICATIONS	2
1.1. CMA-181GW	2
1.2. CMA-181GW OPERATIONAL CYCLE.....	3
2. GETTING STARTED.....	5
2.1. INTRODUCTION TO CMA-181GW	5
2.2. RECEIVING AND INSTALLATION.....	6
2.2.1. <i>Electrical</i>	6
2.2.2. <i>Plumbing</i>	6
2.2.2.1. <i>Detergent And Rinse Chemical Dispenser (Optional)</i>	7
2.2.2.2. <i>Safe Ttemp Feature</i>	7
2.2.3. <i>Booster Heater Setup</i>	9
2.2.4. <i>Installer Checklist</i>	9
3. OPERATION	10
3.1. INITIAL SETUP	10
3.1.1. <i>Dema Flow Disc</i>	10
3.1.2. <i>Rinse and Wash Temperatures</i>	10
3.1.3. <i>Post Instructions</i>	10
3.2. STARTUP PROCEDURES.....	10
3.3. OPERATING AND CLEANING INSTRUCTIONS	11
3.4. PREVENTIVE MAINTENANCE CHART	12
3.5. QUICK SERVICE GUIDE.....	13
3.6. TROUBLESHOOTING.....	14
4. PARTS KIT	17
4.1. INITIAL PARTS KIT (P/N 1100.66).....	17
4.2. OPTIONAL DRAIN PUMP KIT INSTALLATION INSTRUCTIONS	18
5. CUSTOMER NOTICE	20
6. ELECTRICAL DIAGRAM.....	21

1. Specifications

1.1. CMA-181GW	METRIC EQUIVALENT	
WATER CONSUMPTION		
PER RACK	.75 GAL.	(2.83 L)
PER HOUR	17.9 GAL.	(67.6 L)
OPERATING CYCLE		
WASH TIME-SEC	94	94
RINSE TIME-SEC	16	16
DWELL TIME-SEC	10	10
TOTAL CYCLE	2 MIN.	2 MIN.
OPERATING CAPACITY		
RACKS PER HOUR	30	30
WASH TANK CAPACITY	2.5 GAL.	(9.46 L)
PUMP CAPACITY	38 GPM	(144 LPM)
WATER REQUIREMENTS		
REQUIRED MINIMUM TEMP. *	110°F	(43°C)
RECOMMENDED TEMP. **	140°F	(60°C)
WATER INLET	½"	1.27cm
DRAIN CONNECTION	1"	2.54cm
RINSE PRESSURE SET	20 PSI±5 PSI	1.41 kg/cm ²
CYCLE TEMPERATURES		
WASH-°F	150°F -160°F	(65.5°C/71°C)
RINSE -°F	180°F -195°F	(82°C/90°C)
FRAME DIMENSIONS		
DEPTH	25"	(63.5 cm)
WIDTH	24"	(60.96 cm)
HEIGHT	33 ¼"	(84.45 cm)
MAX CLEARANCE FOR GLASSWARE	11-1/4"	(28.6 cm)
ELECTRICAL RATING*	208 VOLTS 1 PH—60 Hz	230 VOLTS 1 PH—60 Hz
	33 AMPS	35 AMPS
BOOSTER HEATER	5.3 kW	6.5 kW
WASH PUMP MOTOR	1 HP	1 HP
THIS SYSTEM REQUIRES THREE POWER WIRES, WHICH INCLUDES A CURRENT CARRYING NEUTRAL. AN ADDITIONAL FOURTH WIRE MUST BE PROVIDED FOR MACHINE GROUND.NO GFI BREAKER.		
SHIPPING WEIGHT	234#	(106 kg)

* For machines having "SAFETY TEMP" feature. ** For faster heat recovery.

Note: The required flowing water pressure to the dishwasher is 15-65 PSIG. If pressures higher than 65 PSIG are present, a pressure regulating valve must be installed in the water line to the dishwasher (by others). If flowing pressure is lower than 15 psi, improper machine operation may result.

1.2. CMA-181GW Operational Cycle

The CMA-181GW Operational Cycle has a total cycle time of 2 minutes (120 seconds). The Timing Diagram and the steps listed below detail the individual functions that are executed during each Operational Cycle.

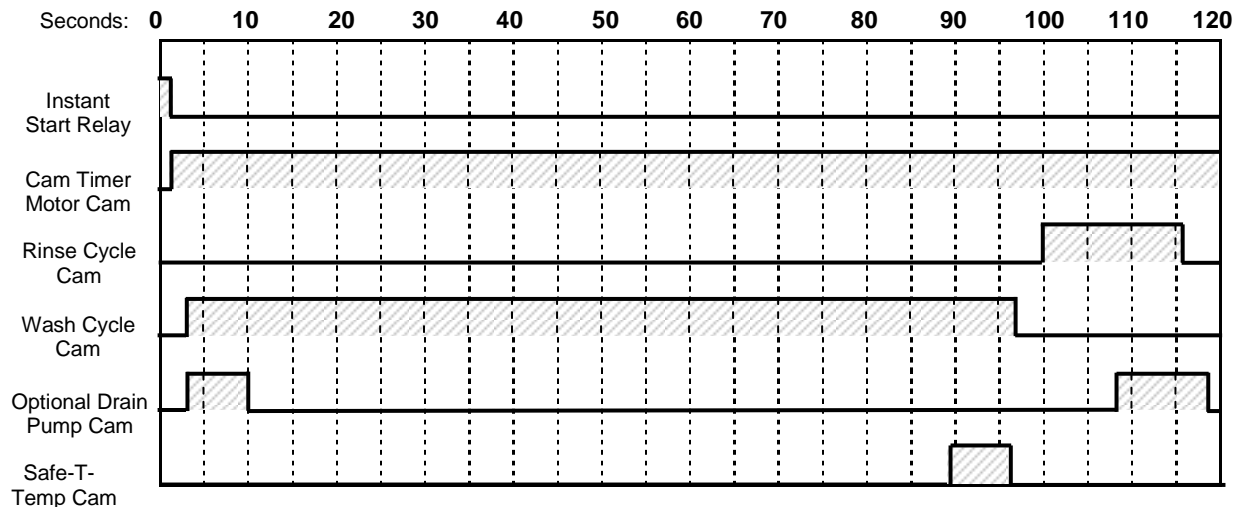

1. With the machine powered up toggling the START switch begins a cycle.
 - a) Toggling the START switch energizes both the Cam Timer motor and the Instant Start Relay. The Instant Start Relay latches ON the power to the Cam Timer motor so that the START switch can be released a moment after it has been toggled without the Cam Timer motor losing power.
 - b) After about 1.5 seconds the Cam Timer's first cam—the Cam Timer Motor Cam—latches ON the power to the Cam Timer motor and drops out the Instant Start Relay. The Cam Timer motor continues to run for a total of 2 minutes, at which time it switches OFF—resetting the Cam Timer—and waits for the next START command.
2. The Cam Timer's third cam controls the Wash Pump. The Wash Pump comes ON about 3 seconds into the Operational Cycle and continues to run for 94 seconds. This 94-second period is the Wash Cycle.
3. At the same time that the Wash Pump comes ON the Cam Timer's fourth cam powers ON the Optional Drain Pump—if one is present—and keeps it running for about 7 seconds before powering OFF. This cam turns ON again midway through the Rinse Cycle and stays ON for 10 seconds, turning OFF 2 seconds after the Rinse Cycle has completed.
4. About 3 seconds after the Wash Cycle has completed the Cam Timer's second cam, which controls the Rinse Cycle, turns ON—energizing the Water Solenoid—and stays ON for 16 seconds. This 16-second period is the Rinse Cycle.

5. When the Cam Timer assembly approaches the final rinse portion of the cycle, the “Safe-T-Temp” fifth micro switch will pause cam timer assembly if the booster heater has not reached 180 degrees. Machine will remain in wash cycle mode until 180-degree rinse temperature is reached, and at this time the Cam Timer will advance automatically into the rinse cycle and dispense 180 degrees rinse water over the dishes.



2. Getting Started

2.1. Introduction to CMA-181GW

The CMA-181GW is a hot water sanitizing, single rack, under-counter glasswasher. It is a standalone machine featuring a self-contained booster heater. The only external connections necessary are power supply, water supply, drainpipe, and optional chemical dispensers. The machine uses re-circulated wash water and fresh water final-rinse.

Operation of the CMA-181GW is extremely user friendly. To initially fill the machine each day, push the Power switch to the "ON" position. The machine will be automatically filled to the correct level.

The booster tank heater will maintain the wash water temperature at 155°F. The booster heater will produce a minimum of 180°F final rinse water each cycle.

The supply water to the CMA-181GW must be a minimum of 140°F at 24 PSI (Pounds per Square Inch) with a 6 GPM (Gallons per Minute) flow rate and 60 GPH (Gallons Per Hour) recovery rate. The pipe supplying the water must be ½" minimum. The plumbing connection is located at the back of the machine. (See specification sheet on page 2).

The drain is a 1" barbed fitting on the back of the machine for easy attachment of your drain hose.

This manual is structured to provide a complete reference guide to the CMA-181GW. It is presented in a manner that all users will be able to comprehend and use as an effective tool in supporting the operation and maintenance of the glasswasher. The first section explains how the machine is packaged and what to look for when receiving the machine.

After unpacking the machine, this manual explains how to install and set up the machine for use. Requirements are given for plumbing, wiring, and space considerations. *These attributes of the machine are always taken into consideration by our well-trained sales representatives prior to the order being placed.* In the manual, guidance is also given for installation to ensure that the machine will be able to run at optimum conditions.

The Operation Section of the manual may be used for instruction and procedures when required. We make this portion of the manual easy to understand so that all levels of operators may be able to read and comprehend the operation of the machine. The function of the machine itself is mostly automatic and takes little training to put into full operation. The Operation Section also includes diagnostic considerations for the machine when problems occur.

DISCLAIMERS

CMA expressly disclaims any and all warranties, express or implied, relating to the installation of any and all CMA equipment that is installed by chemical dealers, contracted servicers or third party servicers to CMA equipment. If the installation instructions are not followed exactly (to the letter), or, if any person or company conducting the installation of the CMA equipment, revise the installation procedures or alter the instructions in any manner, the CMA warranty becomes void. If, due to the improper installation of CMA equipment, this equipment ceases to operate properly or affects other parts of the CMA dishwashing equipment, in that the other parts become defective, the CMA warranty becomes void. CMA will not be liable or responsible or warrant CMA equipment, due to improper installation of any CMA model dishwasher.

CMA does NOT endorse "Tankless On-Demand" water heaters for use on CMA Dishmachine products. On most applications, the volume of hot water required for commercial dishmachines exceeds the capacity of these types of heating sources. You will find that most, if not all, commercial dishmachines have been programmed with auto-filling features that require quick filling, with a designated limited time.

CMA DOES endorse, and highly recommends, the standard "tank" style water heaters, sized properly to handle each particular facility with their water heating requirements. A "tank" style water heater stores and supplies a large capacity of preheated water before providing hot water to the dishmachine. To meet required health codes, there must be a reliable and consistent flow of adequate hot water supplied to the dishmachine. If the facilities' "tank" style water heater is marginal in size, CMA recommends installing a proper size Hatco Booster Heater, a CMA's E-Temp 40 or 70-degree-rise Booster Heater (that can be installed on CMA Conveyors), or a CMA Temp-Sure Booster Heater (for door and undercounter dishmachines). All are designed to adequately achieve results.



WARNING! This product can expose you to chemicals which are known to the State of California to cause cancer, birth defects, or other reproductive harm. For more information visit www.P65Warnings.ca.gov

2.2. Receiving and Installation

The glasswasher is shipped from the factory in a corrugated box on a wooden pallet. The installation guidelines give a systematic procedure for setting up the machine.

Start by removing the packaging material. Unwrap the machine and check for the following component parts:

The Wash Tank Scrap Screen is shipped inside the wash cavity of the machine. This screen must be in place during operation. It has been designed to perform two basic functions:

1. Strain water that is circulating through the spray arms and pump assembly.
2. A basket to catch broken glass, or heavy solids that may plug the impeller.

Set the machine in place, and level from side-to-side and front-to-back to prevent door leaks.

Steam generated from normal operation may escape from door. Wood, laminates, veneers, etc. are unsuitable materials for use in areas exposed to dishwasher steam and detergents. Stainless steel or other moisture-resistant shields are recommended for surfaces adjacent to sides and tops of under counter dishwashers.

2.2.1. Electrical¹

Prior to installation make sure the electrical supply is compatible with the specifications on the machines data plate.

Single-phase 230 volt, 60 Hz dedicated circuit should be used to supply electrical energy to the CMA-180UC dishwasher (see specification sheet page 2). This system requires three power wires, which include a current carrying neutral. An additional fourth wire must be provided for ground. Approximately 4-feet of ¾" flexible conduit with power leads (L-1, L-2, Neutral and Ground) extending out of the conduit are provided for easily connecting the power at installation. The power connection must be located such that there is sufficient length of the flexible conduit remaining to permit the machine to be moved for cleaning.

WARNING: Electrical and grounding connections must comply with the applicable portions of the National Electrical Code and/or other local electrical codes.

Note: For supply connections, use copper wire only rated at 90 degree C minimum

2.2.2. Plumbing²

Notice to Plumber: The plumber connecting this machine is responsible for making certain that the water lines are THOROUGHLY FLUSHED OUT BEFORE connecting to the dishwasher.

The machine is equipped with a ½" NPT connection located at the lower left-hand corner (facing the back) of the machine. A 140°F water line should be plumbed to this point (see specification sheet page 2). The water line used must be of sufficient length and flexibility to permit the machine to be moved for cleaning.

The supply water to the CMA-180UC must be a minimum of 140°F at 24 PSI (Pounds per Square Inch) with a 6 GPM (Gallons Per Minute) flow rate and 60 GPH (Gallons Per Hour) recovery rate. The pipe supplying the water must be ½" minimum. The plumbing connection is located at the back of the machine. (See specification sheet on page 2). **Note:** high iron levels in the water supply can cause staining and may require an iron filter. High chlorine levels in the water supply can cause pitting and may require a chloride removal system. If an inspection of the dishwasher or booster heater reveals lime buildup after the equipment has been in service, water treatment is recommended. If water softener is already in place, ensure there is a sufficient level of salt.

^{1,2}**All electrical and plumbing connections must be made by a qualified person who will comply with all available Federal, State, and Local Health, Electrical, Plumbing and Safety codes**

Warning: If water pressure exceeds 50 PSI, pressure reducing valve (PRV) is recommended.

The supply water to the CMA-181GW must be a minimum of 140°F at 24 PSI (Pounds per Square Inch) with a 6 GPM (Gallons Per Minute) flow rate and 60 GPH (Gallons Per Hour) recovery rate. The pipe supplying the water must be ½" minimum. The plumbing connection is located at the back of the machine. (See specification sheet on page 2).

CMA recommends utilizing a water softening system to maintain water hardness measurements of 3.5 gpg (grains per gallon) or less. This will assure maximum results and optimum operation of the dishmachine.

2.2.3. Detergent And Rinse Chemical Dispenser (Optional).¹

Optional built-in chemical dispenser Assembly (CMA P/N 14585.00) has easy access for chemical settings behind the front kick panel. Both initial charge and recharge is factory pre-set. Basic settings for both detergent and rinse speed are 50%. Push the prime switch in and hold until chemicals feed line is full. Operating fine-adjustment screws on the dispenser can control the amount of chemicals drawn into chemical lines.

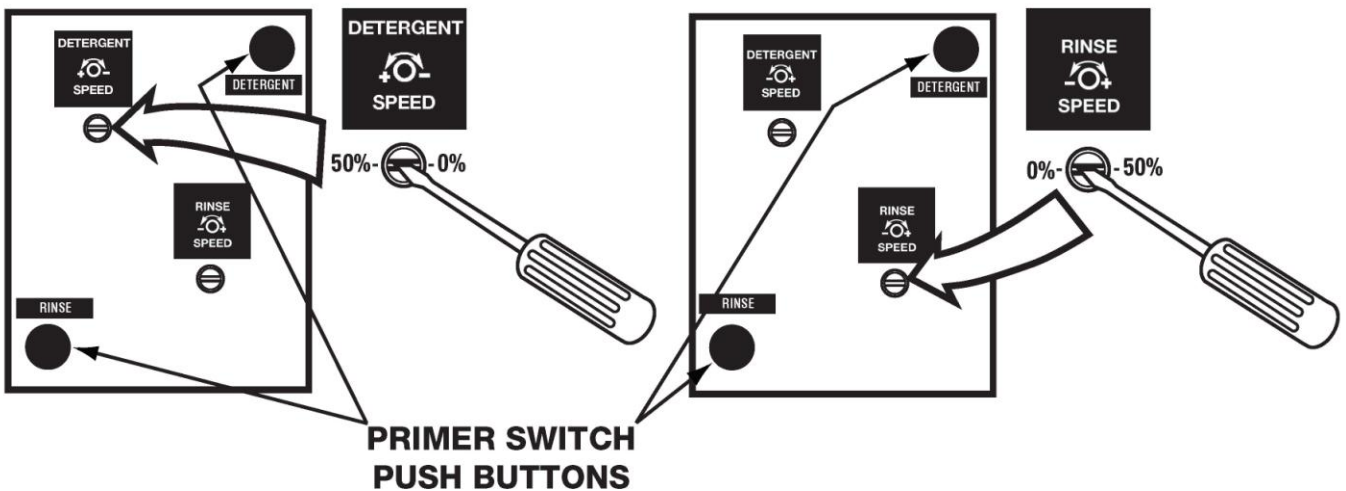

Undercounter machine with the optional dispenser must be ordered separately, as option at time of order. Optional dispenser has to be pre-wired prior to shipment (see electrical diagram for wiring options).

Note: Use only commercial-grade detergents and rinse aids recommended by your chemical professional. Do not use detergents and rinse aids formulated for residential dishwasher

2.2.4. Safe Ttemp Feature

The CMA "SafeTtemp" feature assures the final rinse cycle is always at a consistent minimum of 180 degrees.

¹ All electrical and plumbing connections must be made by a qualified person who will comply with all available Federal, State, and Local Health, Electrical, Plumbing and Safety codes

How it works: the “SafeTemp” function operates off the 5th cam (labeled “SafeTemp”) on the timer assembly. When the cam timer assembly completes the wash cycle, and approaches the final rinse portion of the cycle, the “SafeTemp” micro switch will drop into the cam slot and pause cam timer assembly if the booster heater has not reached 180 degrees. Machine will remain in wash cycle mode until 180 degree rinse temperature is met, and at this time the cam timer will advance automatically into the rinse cycle and dispense 180 degrees rinse water over the dishes.

Note: if Safe Ttemp cam is not to be used, it becomes a spare cam.

CMA -180“SafeTemp” Installation Instructions:

- 1) Remove the 4cam timer assembly (note wire colors and wire placement for all 4cam timer micro switches) and install 5cam timer in its place.
- 2) Place all wires removed from 4cam timer assembly in exact position on 5cam timer assembly.
- 3) The cam timer motor receives (1) yellow wire and (1) white wire (re-connect the yellow wire only from glasswasher harness to the motor).
- 4) The “SafeTemp” 5 cam timer assembly kit includes a two white harness – connect white wire with female bullet connector to the timer motor, stripped end to #22/NC on contactor, and spade end to center terminal 5th micro switch.
- 5) Connect white wire with male bullet connector from the kit to the white wire with female bullet connector coming from glasswasher harness, stripped end to #21/NC on contactor, and spade end to top terminal on 5th micro switch.

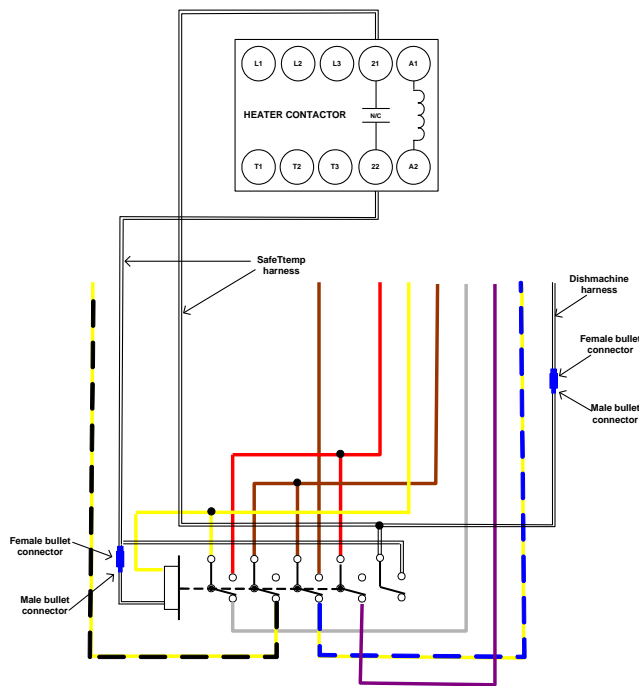

2.2.5. Booster Heater Setup

The booster tank must be filled with water before the heating element is energized. For this reason the "High Limit Switch" has intentionally been disconnected at the factory and will require re-connection before the heating element will turn on.

Follow the procedure below to complete the initial installation:

1. Close the door on the machine.
2. Turn the Power switch to the "ON" position.
The machine will be automatically filled to the correct level.
3. Turn the Power switch to the "OFF" position.
4. Connect blue wire with disconnect, identified by red tag, to the High Limit Switch which is located behind the thermostat behind the front kick panel.

2.2.6. Installer Checklist

- Glasswasher checked for concealed damage**
- Hot water supply is 140° F (60 C) — minimum**
- Incoming water supply line is ½" — minimum**
- Incoming water supply is 6 GPM minimum at 24 PSI**
- Supply circuit breaker for machine is properly sized (50 amp)**
- Service voltage and phase type are correct to machine data plate**
- If drain pump is used, drain hose rises 12 to 16" before dropping to drain**
- Drain hose is installed with air gap (discharge 1" above drain)**
- Glasswasher is properly grounded**
- Glasswasher is properly leveled**
- Machine circuit breaker is labeled "GLASSWASHER"**
- Machine has been "hard-wired" with correctly sized wire**
- Booster tank has been filled with water (before High Limit Switch is reset)**
- High Limit Switch for heater has been reset (after Booster Tank has been filled)**

3. Operation

3.1. *Initial Setup*

3.1.1. Dema Flow Disc

Flow Disc has been placed on the exit side of the water valve. The Flow Disc reduces pressure to the standard recommended 20 PSI.

3.1.2. Rinse and Wash Temperatures

1. Turn the Power switch to the "ON" position.
2. After the machine has warmed up for about ten-minutes, note the wash and rinse temperatures. The wash temperature must be 155°F minimum. The rinse temperature must be 180°F minimum³. If necessary, adjust the temperatures by removing the front kick panel and turning the thermostat adjustment clockwise to increase, counterclockwise to decrease. This one adjustment controls both temperatures.

3.1.3. Post Instructions

1. Install wall chart and instruct machine operator on proper cleaning and operation of the CMA-181GW.

3.2. *Startup Procedures*

1. Open the door of the machine and check that the scrap screen is in place, and that the spray arms and end plugs are secure.
2. Close the door of the machine and turn the Power switch to the "ON" position. The machine will be automatically filled to the correct level..
3. Once the water is filled to the proper level, press the rocker switch marked "START" – the machine will automatically begin its cycle.
4. Check machine's operating temperatures — Adjust if necessary. See section 3.1.2 Rinse and Wash Temperatures.
5. At the end of the wash period, drain the machine by pushing the rocker switch marked "DRAIN". Clean the wash tank screen and scrap tray screen. Remove and clean the spray arms. (See wall chart instructions).

³ Rinse cycle temperature must be observed during a rinse cycle while the machine is in operation..

3.3. Operating and Cleaning Instructions

**OPERATING INSTRUCTIONS FOR MODEL CMA-180UC AND 181GW
INSTRUCCIONES DE OPERACION DE MODELO CMA-180UC Y 181GW**



1 Turn on power and machine will be automatically filled to correct level.
Prenda la maquina y automaticamente va a llenar al nivel correcto.

2 Start machine by pushing start button.
Para empezar la maquina, cierre la puerta y oprima el boton de encendido.

CAUTION: DO NOT START until wash temperature reads 150°.
No empiece el lavado hasta que la temperatura sea 150°.

150° °F
WASH TEMP 150°-160°



**CLEANING INSTRUCTIONS FOR MODEL CMA-180UC AND 181GW
INSTRUCCIONES DE LIMPIEZA DE MODELO CMA-180UC Y 181GW**

3 Drain machine by pressing and holding drain button.
Para vaciar la maquina: Oprima y mantenga oprimido el boton de vaciado.

4 Turn off power.
Apague La Maquina

5 If spray arms are clogged remove by turning bearings counter clockwise.
Si los brazos de rociado se tapan, es necesario sacarlos desenroscandolos para el lado izquierdo.

6 Inspect top and bottom spray arm jets daily. Use toothpick and push trash into spray arm. Remove end plugs and flush with water.
Use un picadientes (palillo) para abrir los orificios. Destapar por las puntas, removiendo el tapon y enjuagelos con agua.

7 Hand remove and thoroughly clean filter, scrap screen and scrap basket under faucet or Pre-Rinse Hose every shift. Only for 180UC.
Remueva el filtro de el interior de el tanque de desperdicios. Lave el filtro y los dos cedazos con el rociador de agua cada turno. Solamente en el modelo 180UC.

8 Replace all (3) screens back into position. Only for 18UC.
Reinstale el filtro y los dos cedazos apropiadamente. Solamente en el modelo 180UC.

5-2017

CMA PN: 06265.10

3.4. Preventive Maintenance Chart



PREVENTIVE MAINTENANCE



1 If rinse arm jets are clogged, remove rinse arm (by turning bearing counter clockwise) and clean out rinse jets with paper clip or small pointed object.

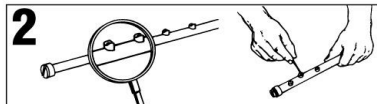

2 Inspect top and bottom spray arms daily. Use toothpick to push debris into spray arm. Remove end plugs and flush with water.

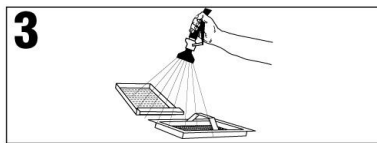

3 Remove and thoroughly clean scrap tray, and scrap drawer daily.

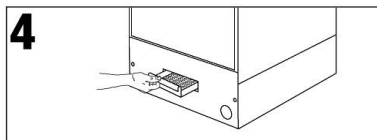

4 Replace screens after cleaning.

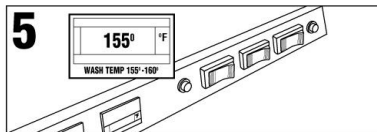

5 Confirm wash temperature is 155°F.

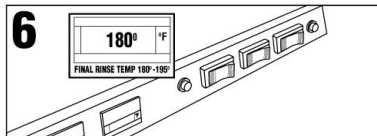

6 Check rinse temperature minimum 180°F. Notify supervisor if rinse temperature is below 180°F.

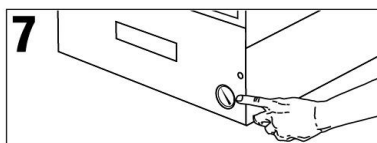

7 Check rinse pressure 15-22 psi.

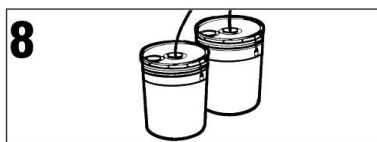

8 Check chemical containers for product. Confirm correct product line is in the bucket.
RED - Detergent
BLUE - Rinse Aid



9 Check machine for leaks.

3.5. Quick service guide

MODEL: CMA 181GW HIGH TEMP UNDER COUNTER

TECHNICAL ISSUE	CAUSE	SOLUTION
Door leaks	Machine not level	Adjust machine legs to level
	Machine is leaning forward	Adjust machine legs to level
	Wash arm end cap missing	Replace end cap
	Door gasket	Replace gasket
Thermometer failure	Loose wire at display, board or transformer	Secure connectors
	Faulty temperature sensing wire	Correct, replace
	Faulty temperature sensing unit	Replace unit
Rinse water temperature low /high	Faulty transformer	Replace transformer
	Scaled heating element	Clean scale from heater
	Booster heater's thermostat not properly set	Adjust thermostat
Pump motor not running	Incoming water temperature to booster heater below 140 F	Adjust external water heater in the facility
	Loose lead connections	Check and crimp connectors
	Faulty # 3 micro switch	Replace micro switch
	Faulty contactor	Replace contactor
Pump motor runs continuously	Faulty wash pump motor	Replace wash pump motor
	Faulty # 3 micro switch	Replace micro switch
Low water pressure at the final rinse	Faulty contactor	Replace contactor
	Water regulator not adjusted properly	Adjust regulator to 18-20 PSI
	Clogged final rinse spray jets	Clean jets
	Missing final rinse spray end cap	Replace end cap
Scrap trap overflows overnight	Low incoming water pressure from facility	Increase pressure to 18-20 psi
Poor cleaning results	Faulty water solenoid diaphragm	Clean or replace diaphragm
	Low wash or rinse water temp.	Check temperature settings
	Wash arm bearing or jets	Clean bearing and arm jets
Wash tank will not drain	Rinse arm bearing or jets	Clean bearing and arm jets
	Tank discharge screen dirty	Clean screen
	Drain valve not operating	Check power to drain valve
	Drain valve faulty	Replace drain valve

3.6. Troubleshooting

PROBLEM	LIKELY CAUSE	SOLUTION
Machine inoperative	Power off at circuit breaker	Reset circuit breaker
	Defective power switch	Replace power switch
Motor inoperative	Door is open	Close door
	Control panel is pulled out	Secure control panel
	Defective reed switch	Replace reed switch
	Defective timer assembly	Replace timer assembly*
	Defective pump motor contactor	Replace contactor
	Defective motor	Replace motor
Motor runs with door open	Defective reed switch	Replace reed switch
	Defective pump motor contactor	Replace contactor
Heater (no heat)	High limit switch opened or defective	Reset or replace switch
	Defective thermostat	Replace thermostat
	Defective heater contactor	Replace heater contactor
	Defective heater	Replace heater
Heater (never turns off)	Defective thermostat	Replace thermostat
	Defective heater contactor	Replace heater contactor

*The timer assembly motor or micro switches can be replaced independently if that's the only component that's failed.

Operation

PROBLEM	LIKELY CAUSE	SOLUTION
Low heat during operation	Low incoming water temperature (below 140° F)	Turn up supply water heater Insulate supply water pipe
	Thermostat out of adjustment	Adjust thermostat
	Cold water mixing with supply	Isolate hot water from cold water
	Defective heater	Replace heater
Low rinse water pressure	Pressure regulator out of adjustment	Adjust pressure regulator
	Defective pressure gauge (actual pressure is okay)	Replace pressure gauge
Regulator at maximum but rinse pressure still low	Insufficient water supply flow	Supply larger supply line
	Defective water solenoid valve	Replace water solenoid valve
Low rinse water flow	Low rinse water pressure	See "Low rinse water pressure" in PROBLEM column
	Limed up rinse arm spray nozzles	De-lime rinse arm nozzles
No rinse water flow	Defective water solenoid valve	Replace water solenoid valve
	Defective (Rinse Relay) ice cube relay	Replace ice cube relay
Rinse water runs with door open	Defective reed switch	Replace reed switch
With power on, activating start switch does not begin cycle	Defective start switch (cycle light will not light either)	Replace start switch
	Defective timer assembly	Replace timer assembly*

*The timer assembly motor or micro switches can be replaced independently if that's the only component that's failed.

Operation

PROBLEM	LIKELY CAUSE	SOLUTION
Start switch requires > 1 second activation to run cycle	Defective (Instant Start) ice cube relay	Replace ice cube relay
Activating fill switch does not fill machine	Defective drain/fill switch	Replace drain/fill switch
	Defective water solenoid valve	Replace water solenoid valve
Fill (rinse water) won't shut off	Defective water solenoid valve	Replace water solenoid valve
	Defective drain/fill switch	Replace drain/fill switch
	Defective timer assembly	Replace timer assembly*
	Defective (Rinse Relay) ice cube relay	Replace ice cube relay
Activating drain switch does not drain machine	Drain hose is kinked	Un-kink drain hose
	Defective drain/fill switch	Replace drain/fill switch
	Defective drain valve	Replace drain valve
Cycle light does not light while cycle runs	Defective cycle light	Replace cycle light (green)
Power light does not light but machine runs	Defective power light	Replace power light (red)
Wash tank or final rinse temperature does not display	Defective digital thermometer	Replace digital thermometer
Both the wash tank temperature and the final rinse temperature do not display	Defective thermometer transformer	Replace thermometer transformer
Wash tank or final rinse displays wrong temperature	Defective digital thermometer	Replace digital thermometer
	Defective thermister	Replace thermister

*The timer assembly motor or micro switches can be replaced independently if that's the only component that's failed.



4. Parts Kit

4.1. Initial Parts Kit (P/N 1100.66)

P/N	DESCRIPTION	Qty
15504.00	Motor Contactor, 2-Pole 20 Amp	1
15504.50	Heater Contactor, 2-Pole 35 Amp	1
00501.00	2-Minute Timer Motor	1
00631.00	Ice Cube Relay 120 V	1
00707.00	½ Water Solenoid Repair Kit JE	1
00738.15	Solenoid Coil JE 220V	1
15523.00	Rocker Switch Start Momentary	1
15523.50	Rocker Switch Drain/Fill	1
15524.00	Rocker Switch Power Maintained	1
00556.10	Reed Switch	1
03623.00	1/2" Vacuum Breaker Repair Kit – Watts	1
00707.00	1/2" Water Solenoid Repair Kit – J/E	1
04113.00	L1X/L1-C Drain Valve 120V	1
00206.70	Pump Seal Kit	1
13417.89	Heater Thermostat	1
17523.60	High Limit Switch 200°F	1
00411.00	Microswitch	1
03203.01	Dual Temperature Display Kit	1
00738.15	Solenoid Coil JE 115V/60Hz	1

4.2. Optional Drain Pump Kit Installation Instructions

Kit P/N 15502.50 Includes:

ITEM NO.	NO. REQ'D	P/N	DESCRIPTION
1	1	15605.00	Drain Hose w/Goose Neck
2	1	15503.00	Drain Motor Ultra Jet (CMA 180 UC)
3	2	00441.00	Wire Nuts
4	1	15601.60	Hose 1" ID 14" Pump to Manifold
5	1	15603.00	Drain Line Gooseneck Stainless
6	6	03101.00	Hose Clam # 16 1"

Instructions:

1. Attach drain line gooseneck # 5 from the kit to the manifold with hose clamps # 6 (see Fig 1).



Figure 1

2. Start by removing the existing drain hose (grey) #1 from the Drain Valve's black hose #2 (See Figure 2)

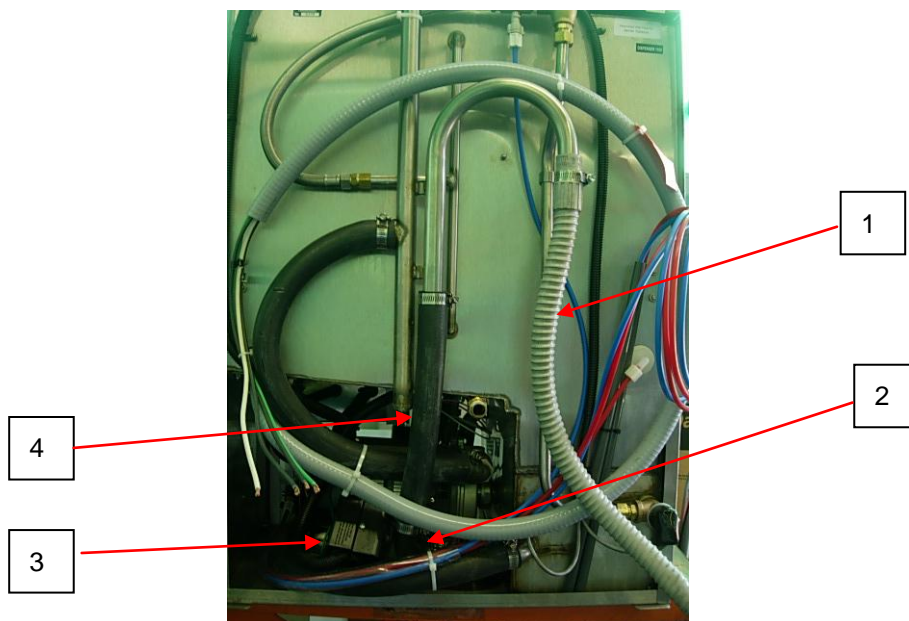

Figure 2

3. Connect the pump inlet to the Drain Valve's black hose and secure drain pump with the hose clamps #6.
4. Locate white and purple wires exposed and safe-ended in the back of the machine.
5. Remove terminal cover and connect these wires to the two white wires from the pump using wire nuts #3 from the kit. Replace the cover.
6. Connect black hose #4 and drain hose #1 to the drain line as you see in illustration above.
7. Secure them with hose clamps #6 from the kit. Drain hose must elevate before dropping into the drain pipe.
8. Rout the drain hose to the drain and provide a 1-inch air gap at the drain.



5. Customer Notice

CMA-181GW Installation Guidelines

Improper installation of this product may void the warranty on this machine. Please follow these guidelines for recommended installation and to ensure the warranty of this model is authorized by CMA Glasswashers.

Glasswasher Installation Requirements

1. Machine **must** be level. Adjust leveling feet to accommodate uneven floor surfaces.
2. Drain height should not exceed maximum height of 16". If there is a floor drain, it is highly recommended the pump drain be removed. Connect supplied drain line to 3-way valve on back of machine and gravity feed to the floor drain.
3. Approximately 4-feet of $\frac{3}{4}$ " flexible conduit with power leads (L-1, L-2, Neutral and Ground) extending out of the conduit are provided for easily connecting the power at installation. CMA recommends a minimum 50-amp dedicated circuit, but you should consult your local building code requirements for proper breaker size.

Activating/Adjusting the Booster Heater

1. Booster heater **must** be filled with water prior to connecting the blue wire from high limit switch. The high limit switch can be found by removing the front panel and locating the red button on the front of the heater tank.
2. Once the booster has been connected, the thermostat should be adjusted to maintain 180°F during the final rinse cycle. The thermostat is located on the front of the booster tank and is accessible by removing the front panel on the machine.

Automatic Dispensing Equipment

Applications utilizing automated dispensers for administering warewash chemicals must use 110v dispenser equipment. There is a 110v power block for installing this equipment inside the control panel.

Electrical Diagram

6. Electrical Diagram

CMA-181GW ELECTRICAL DIAGRAM CONTROL PANEL

Rev.12-2016

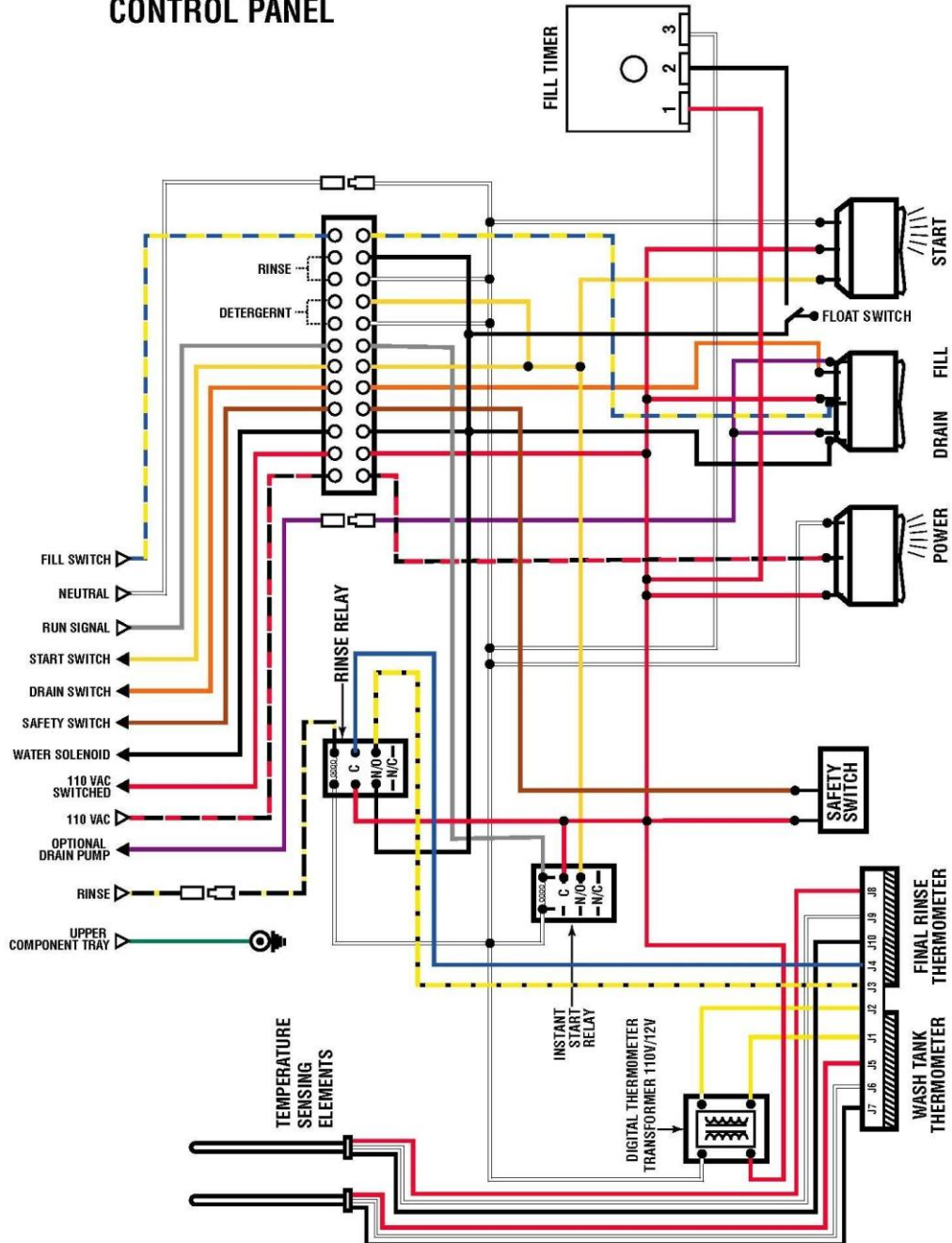

Electrical Diagram

CMA-181GW ELECTRICAL DIAGRAM POWER BOX

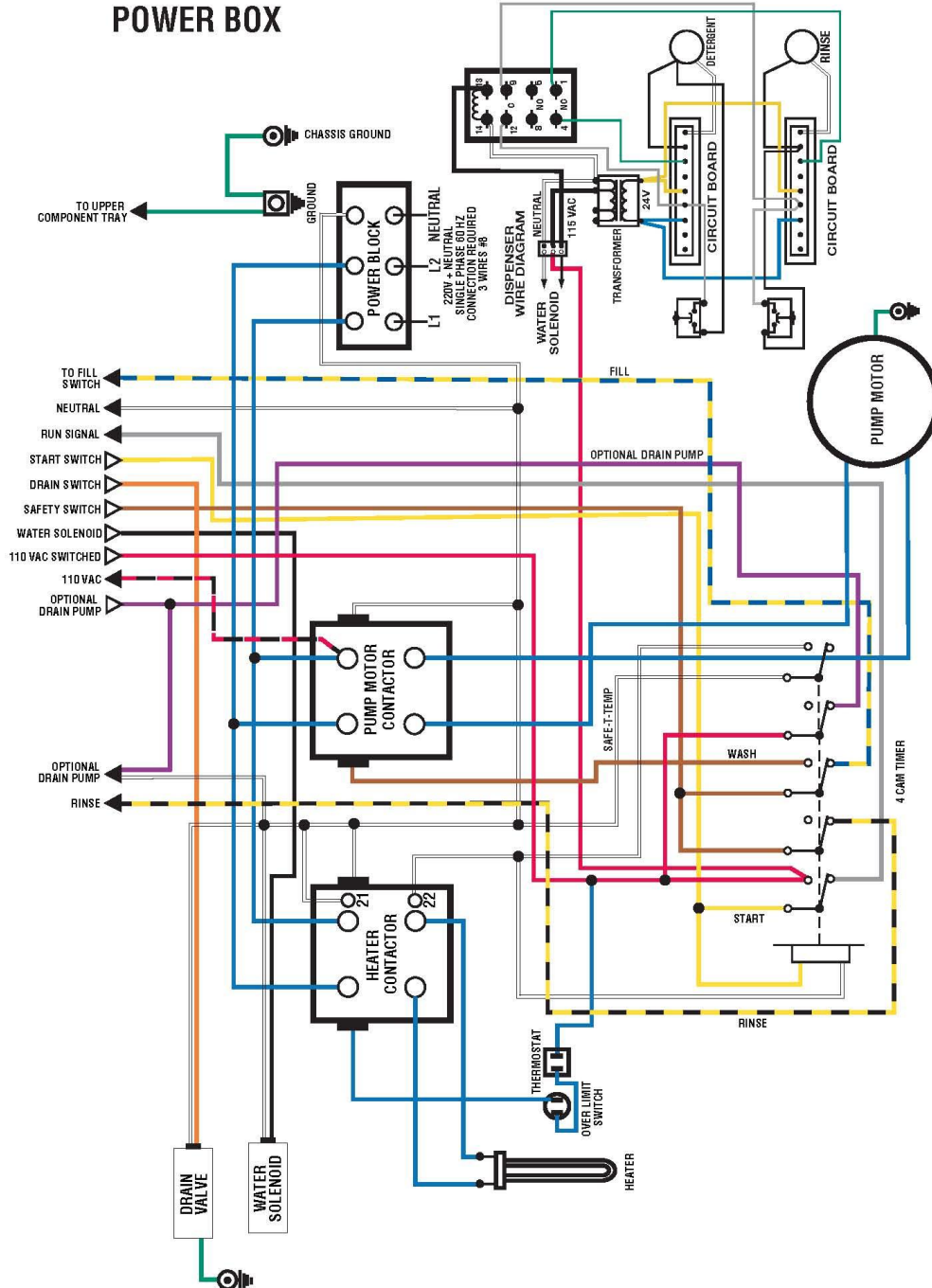

CMA-181GW ELECTRICAL DIAGRAM CONTROL PANEL

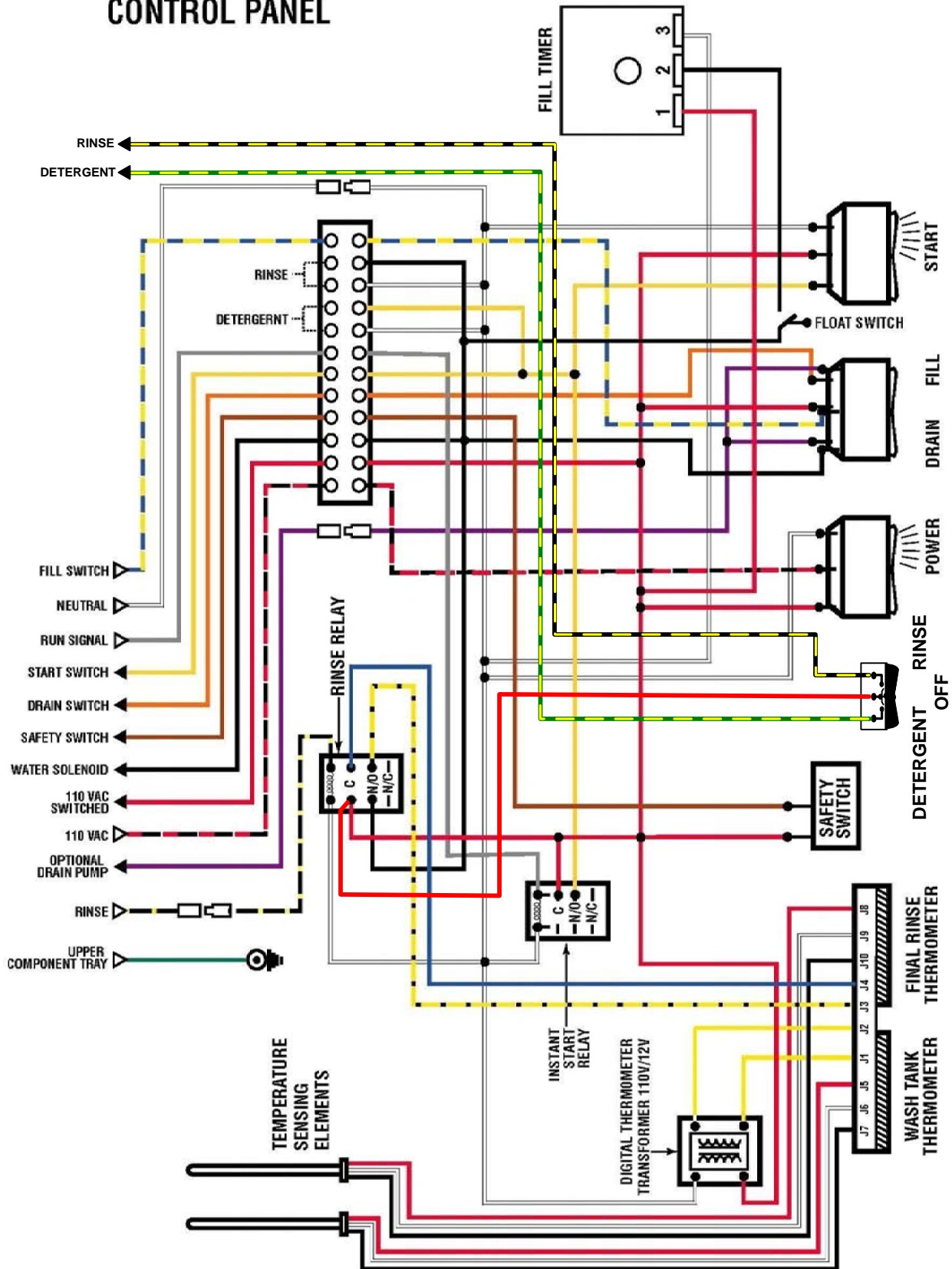

CMA-181GW ELECTRICAL DIAGRAM POWER BOX

Rev. 2.00A
10/28/19

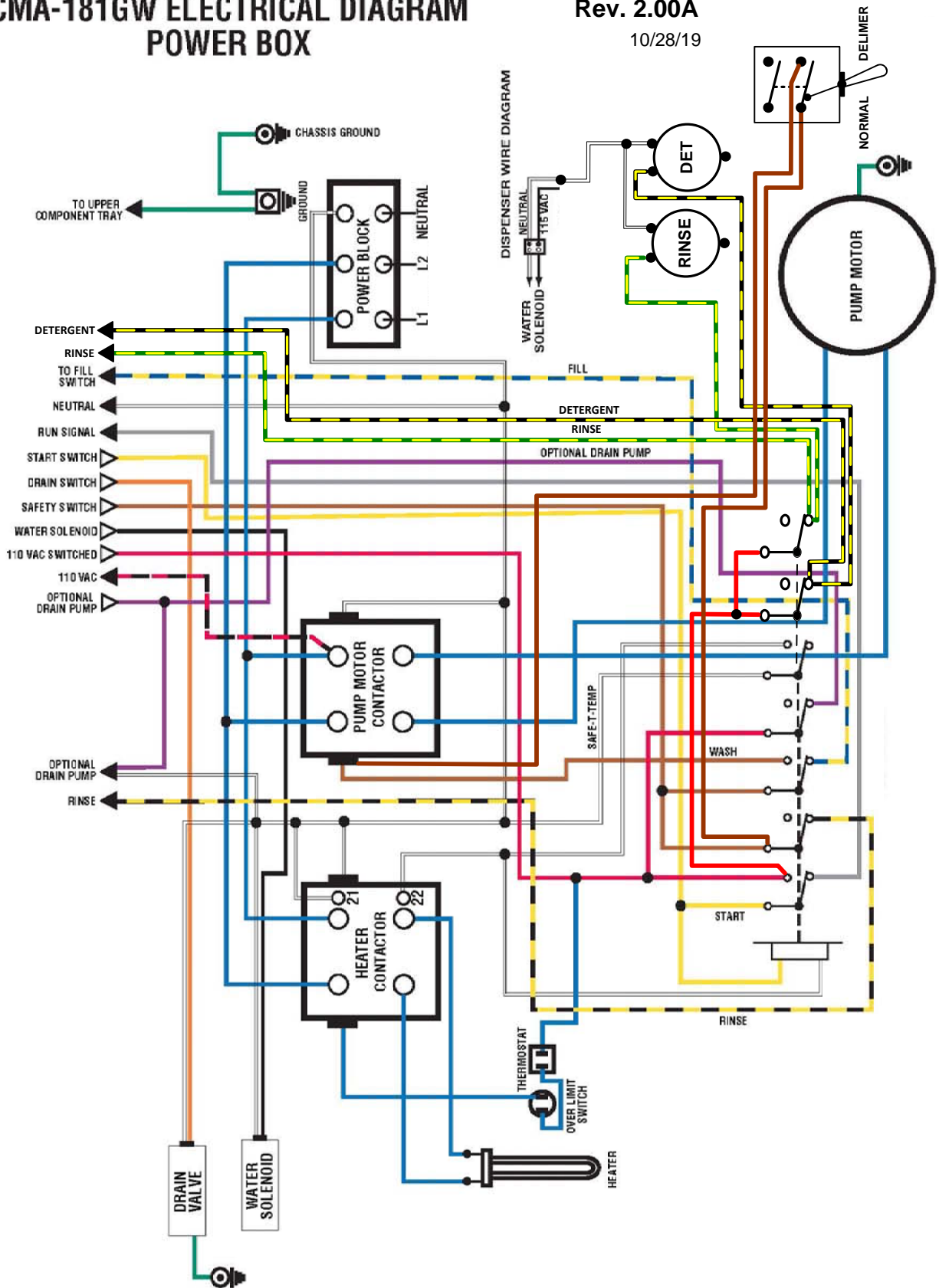

CMA-181GW ELECTRICAL DIAGRAM CONTROL PANEL

September 2022

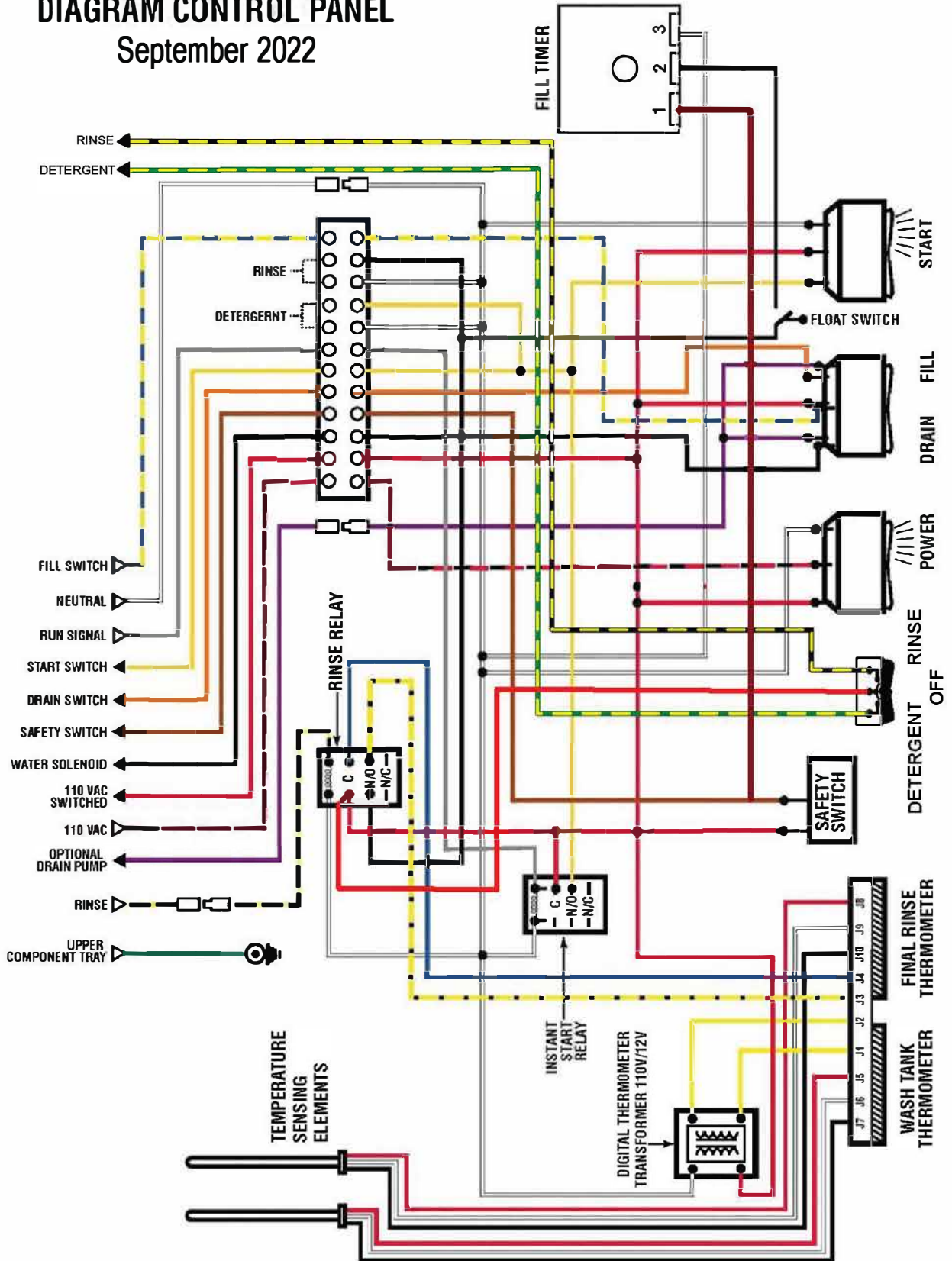

CMA-181GW ELECTRICAL DIAGRAM POWER BOX

Rev. 2.00A
10/28/19

