



# MODEL CMA-130VL

## PARTS MANUAL

Rev 1.00



ENERGY STAR



ENERGY STAR  
PARTNER

DISTRIBUTED EXCLUSIVELY BY  
CMA DISHMACHINES  
12700 KNOTT AVENUE  
GARDEN GROVE, CALIFORNIA 92841

800-854-6417

FAX 714-895-2141

[www.cmadishmachines.com](http://www.cmadishmachines.com)



# TABLE OF CONTENTS

## MODEL CMA-130VL

<b>1. PARTS MANUAL</b> .....	<b>3</b>
1.1. MECHANICAL DRAWINGS.....	3
1.1.1. General Body Parts .....	3
1.1.2. Closing Paneling .....	4
1.1.3. Control Panel and Switches.....	5
1.1.4. Electric Control Components .....	6
1.1.5. Solenoid Valve Group.....	7
1.1.6. Double Solenoid Valve Group.....	7
1.1.7. 3 Ways Connection .....	8
1.1.8. Pressure Switch Group.....	8
1.1.9. Rinse With Steady Temperature.....	9
1.1.10. Booster Pump .....	10
1.1.11. Rinse Aid Dispenser Group .....	11
1.1.12. Detergent Dispenser Group.....	12
1.1.13. Heat Recovery.....	13
1.1.14. Wash Pump.....	14
1.1.15. Drain pump Group .....	15
1.1.16. Turret Group.....	16

# 1. Parts Manual

## 1.1. Mechanical Drawings

### 1.1.1. General Body Parts

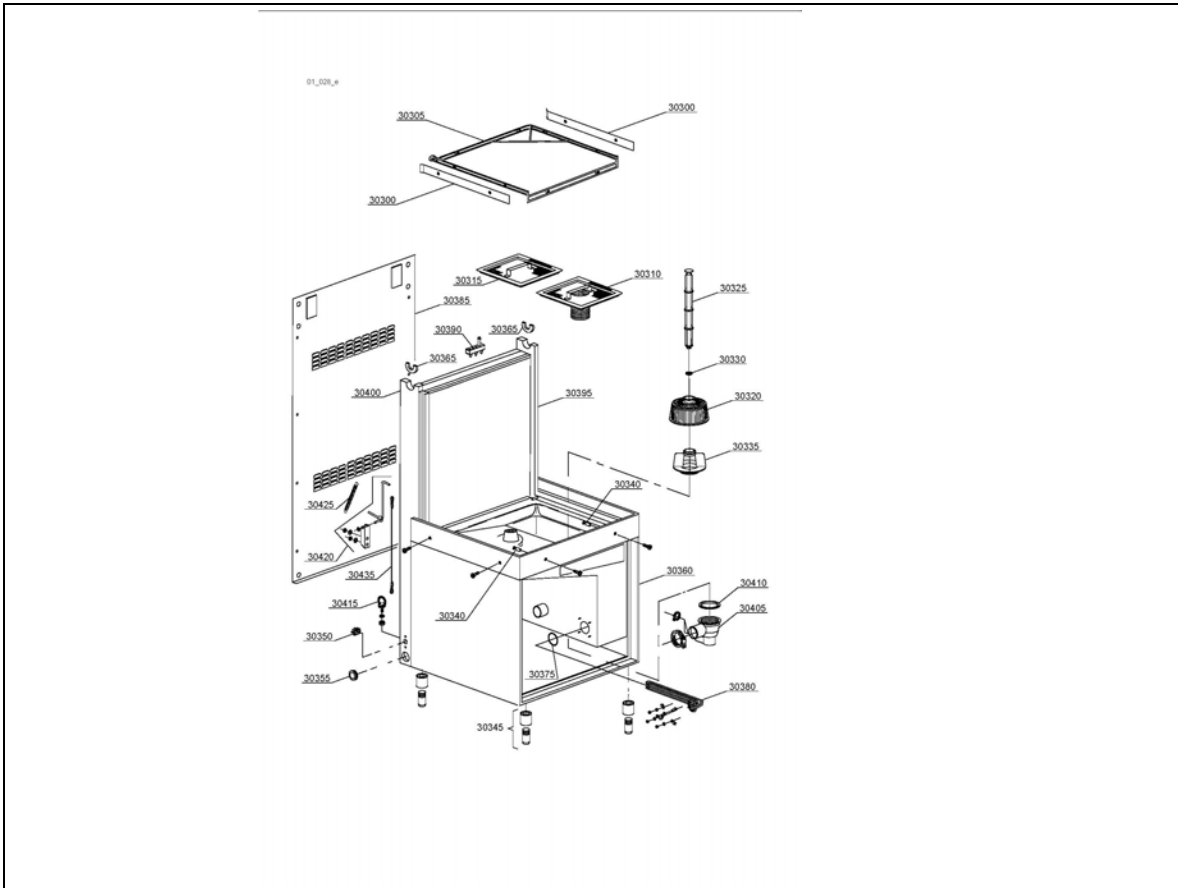

ID	P- Code	DESCRIPTION
30300	2400.01	Guide rail
30305	2400.03	Rack Frame
30310	2400.05	Strainer Plate with a Strainer
30315	2400.07	Strainer Plate
30320	2100.07	Suction Filter
30325	2400.09	Overflow Pipe
30330	2100.57	DEM 40 O-ring
30335	2400.11	Ferrule with Filter
30340	2400.13	Basket Support Holder Pin M6
30345	2400.15	Foot
30350	2400.17	Cable-Fastener with Screw
30355	2400.19	Cable screw cap
30360	2400.21	Frame Assembly

ID	P- Code	DESCRIPTION
30365	2400.23	Right/left Slide Bearing
30375	2101.11	O-ring 151 NBR
30380	2400.25	2,7/2,94KW 230/240V 3 Heating Elem.
30385	2400.27	Back Panel
30390	2400.29	Hood Switch
30395	2400.31	Right Guide Rail Support
30400	2400.33	Left Guide Rail Support
30405	2400.35	Outlet Connection
30410	2101.07	95x75x3 O-ring
30415	2400.37	Security Cord Passage Ring
30420	2400.39	Security System Support
30425	2400.41	Spring
30435	2400.43	Security System Cord

1.1.2. Closing Paneling

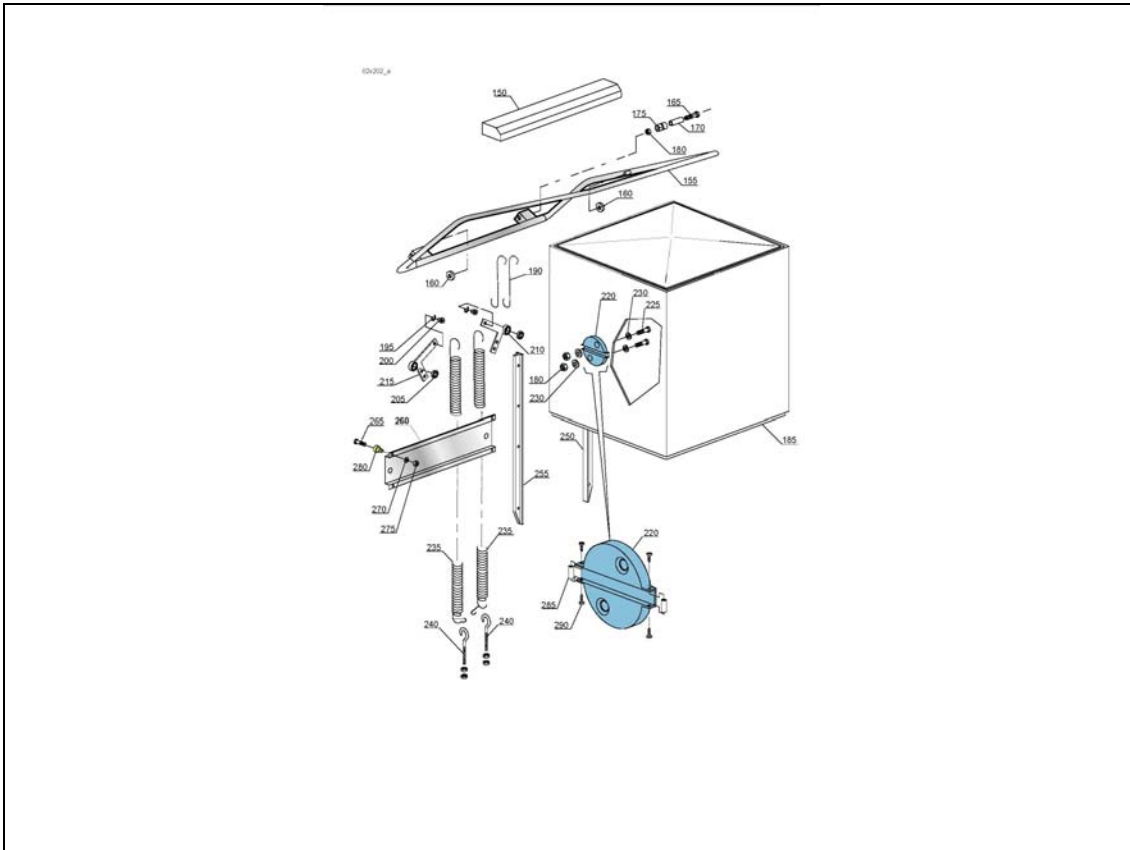

ID	P- Code	DESCRIPTION
150	2400.45	Guide
155	2400.47	Handle
160	2400.46	Bearing
165	2400.51	Screw
170	2400.53	Filter
175	2400.55	Roller
175	2400.55	Roller
180	2400.57	M8 Stainless Steel Self-Lock Nut
185	2400.59	Hood, complete
190	2400.61	Hook
195	2400.63	Ø10 Stainless Steel Snap Ring
200	2400.65	Spring Bush
205	2400.67	Bearing 6002 2RS
210	2400.69	Elbow, Right
215	2400.71	Elbow, Left

ID	P- Code	DESCRIPTION
220	2400.73	Bearing Holder
225	2400.75	Screw
230	2400.77	Gasket Ø 14x8x1,5
235	2400.79	Hood Spring
240	2400.81	Hook Screw
250	2400.83	Guide, Right
255	2400.85	Guide, Left
260	2400.87	Hood Leavers Bearing
265	2400.89	M10x35 TE SS screw
270	2400.91	M10 SS ring washer
275	2400.93	M10 inox nut
280	2400.95	Lifting Rod Pin
285	2400.97	Spacer
290	2101.31	M4x8 Screw

1.1.3. Control Panel and Switches

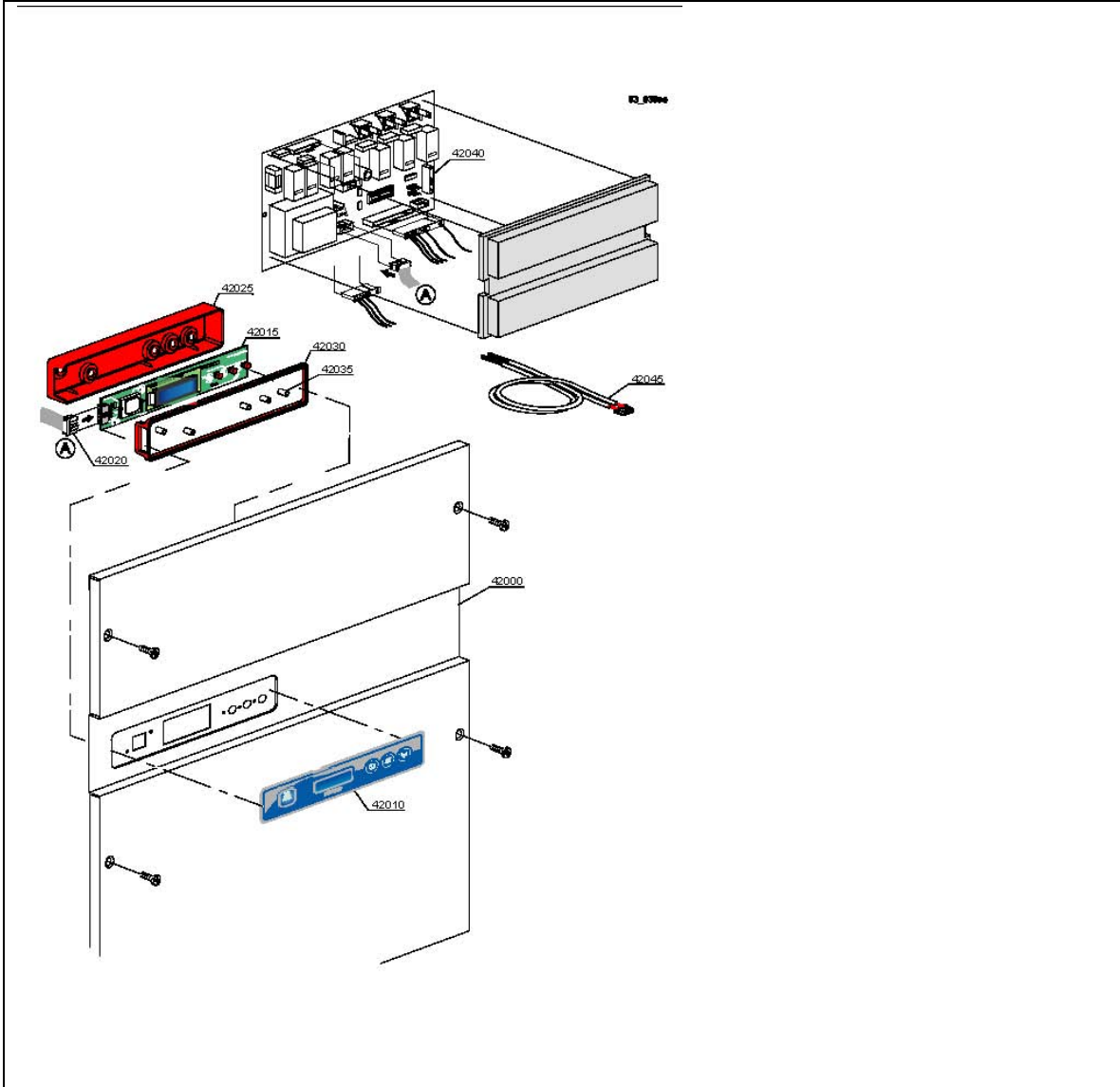

ID	P- Code	DESCRIPTION
42000	2401.29	Control Panel
42010	2401.31	Process Grill Membrane
42015	2401.33	Top Push Button Membrane
42020	2401.35	Plug
42025	2401.37	Cover for Top Board

ID	P- Code	DESCRIPTION
42030	2401.39	Cover Gaskets
42035	2401.41	Board Spacer
42040	2401.43	Top Electronic Timer
42045	2401.45	Sensor

1.1.4. Electric Control Components

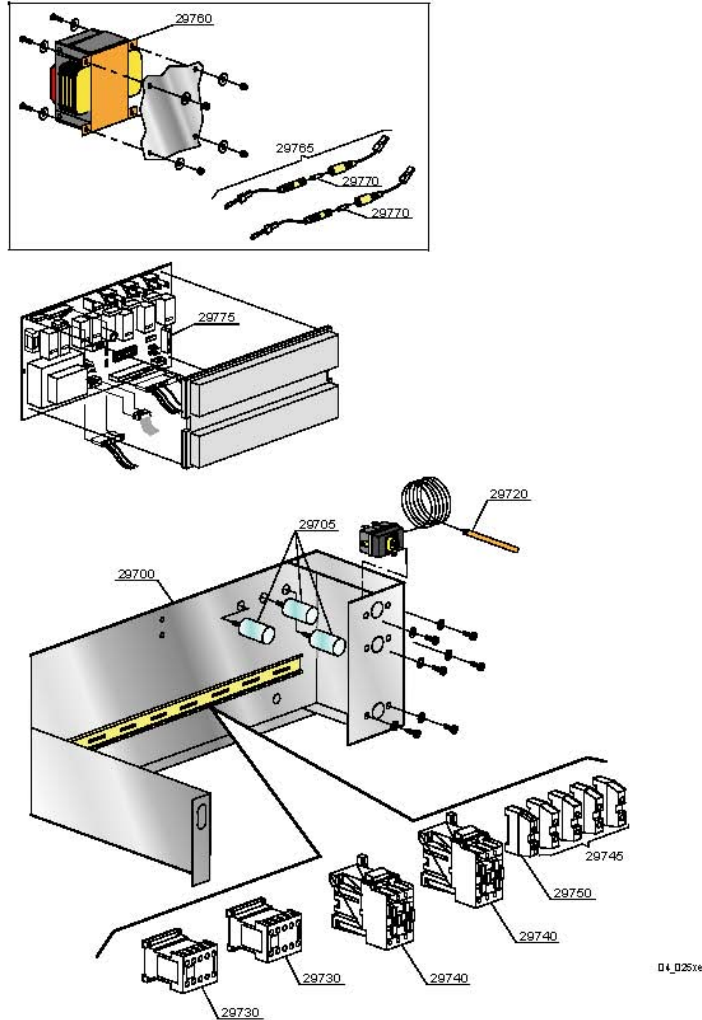

ID	P- Code	DESCRIPTION
29700	2401.47	Electric Component Panel
29705	2401.49	Low Noise Filter
29720	2100.37	Safety Thermostat (or 2105.12)
29730	2100.69	Contacteur TLV, TLB
29730	2401.51	Contacteur 240v 50Hz
29740	2401.53	Contacteur TLP
29740	2100.49	Heater Contacteur

ID	P- Code	DESCRIPTION
29740	2401.55	Contacteur25a/16a 230 50/60
29745	2401.57	Connecting Piece
29750	2401.59	Connecting Piece
29760	2401.61	Transformer 0-230
29765	2401.63	Fuse Holder
29770	2401.65	Fuse
29775	2401.43	Top Electronic Timer

**1.1.5. Solenoid Valve Group**

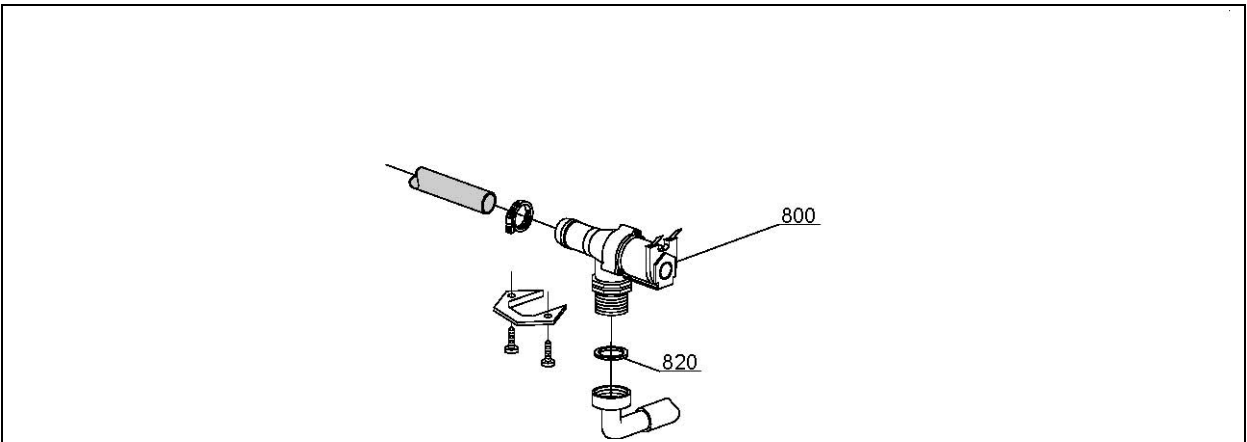

ID	P- Code	DESCRIPTION
800	2401.73	Solenoid Valve

ID	P- Code	DESCRIPTION
820	N.C.	Pressure Reducing Ring

**1.1.6. Double Solenoid Valve Group**

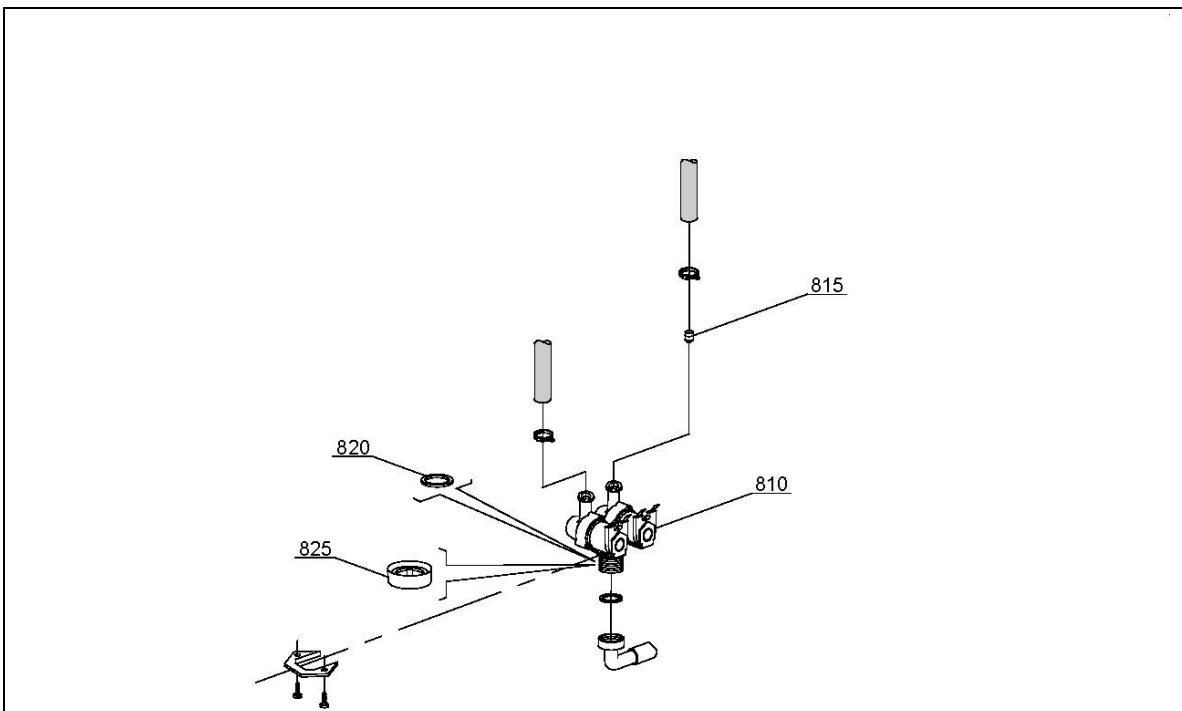

ID	P- Code	DESCRIPTION
800	2401.67	Solenoid Valve
815	2401.69	Pressure Solenoid Valve

ID	P- Code	DESCRIPTION
820	N.C.	Pressure Reducing Ring
825	2401.71	Pressure Reducer

**1.1.7. 3 Ways Connection**

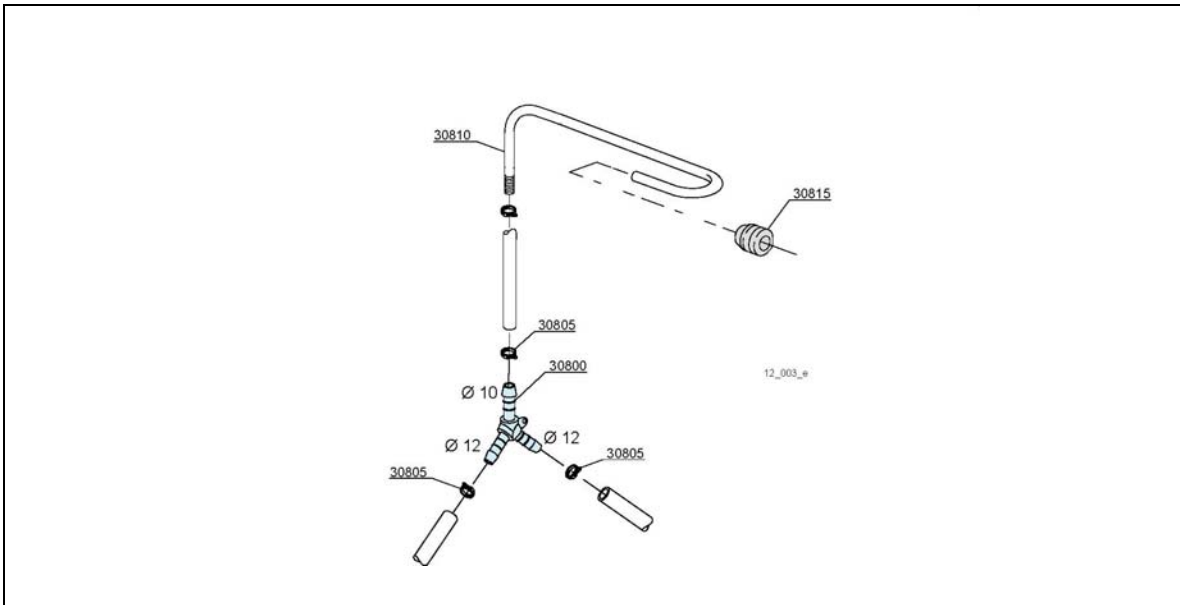

ID	P- Code	DESCRIPTION
30800	2402.59	Y Connection 10/12/12
30805	2101.42	Clamp 12/22

ID	P- Code	DESCRIPTION
30810	2402.61	Rinse Pipe
30815	2401.25	Pipe Gasket

**1.1.8. Pressure Switch Group**

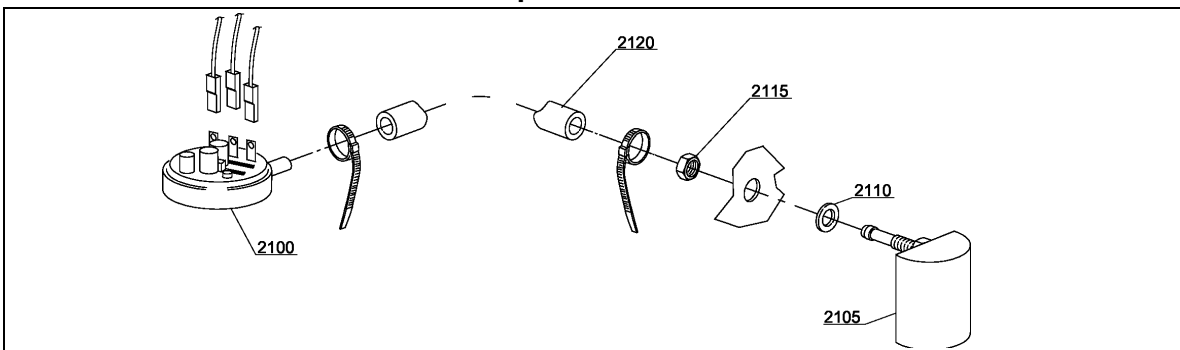

ID	P- Code	DESCRIPTION
2100	2402.93	Pressure Switch PR
2105	2402.95	Air Trap Assembly
2110	2400.77	Gasket 14x8x1.5

ID	P- Code	DESCRIPTION
2115	2402.97	Nut
2120	2402.99	Rubber Hose 4,5x9 EPDM

1.1.9. Rinse With Steady Temperature

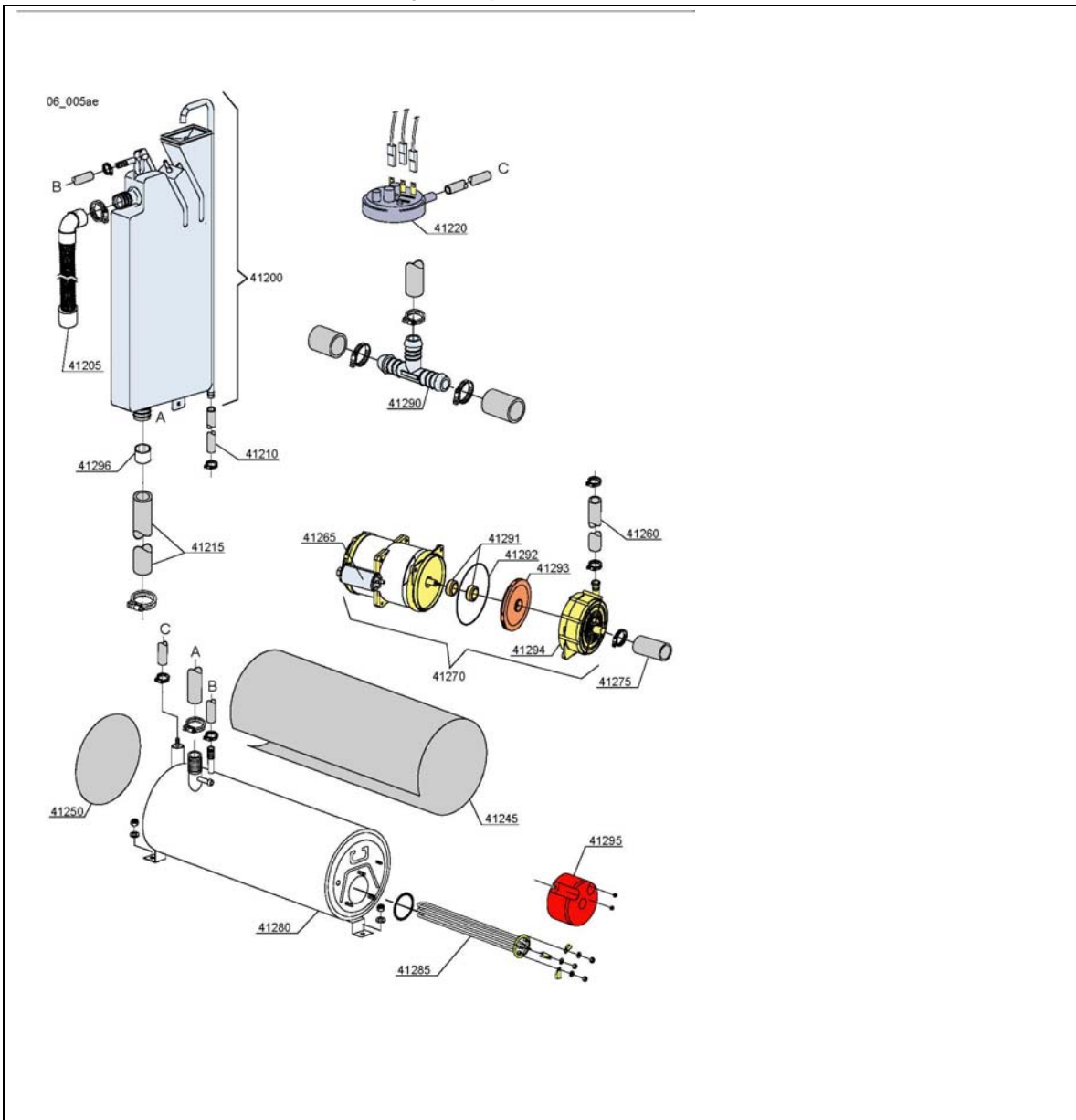

ID	P- Code	DESCRIPTION
41200	2401.75	Break Tank Assy.
41205	2401.77	Long Pipe L=1070
41210	2401.79	Rubber Hose - PVC
41215	-	Pipe Coupling
41220	2100.41	Pressure Switch
41245	2401.81	Boiler Insulation
41250	2401.83	End Piece 160
41260	2401.85	Pump Pipe Coupling
41265	2401.87	Condenser
41270	2401.89	Booster Pump 220/240v
41275	2401.85	Pump Pipe Coupling

ID	P- Code	DESCRIPTION
41280	2401.91	Boiler
41285	2401.93	Heating Element 9kW
41285	2401.95	Heating Element 12kW
41285	2401.97	Heating Element 6kW
41290	2401.99	3 Way Plastic Fitting
41291	2402.01	Rotating Seals
41292	2402.03	O-Ring Gasket EPDM
41293	2402.05	Pump Rotor
41294	2402.07	Scroll
41295	2402.09	Heating Element Cover

1.1.10. Booster Pump

07\_003xe

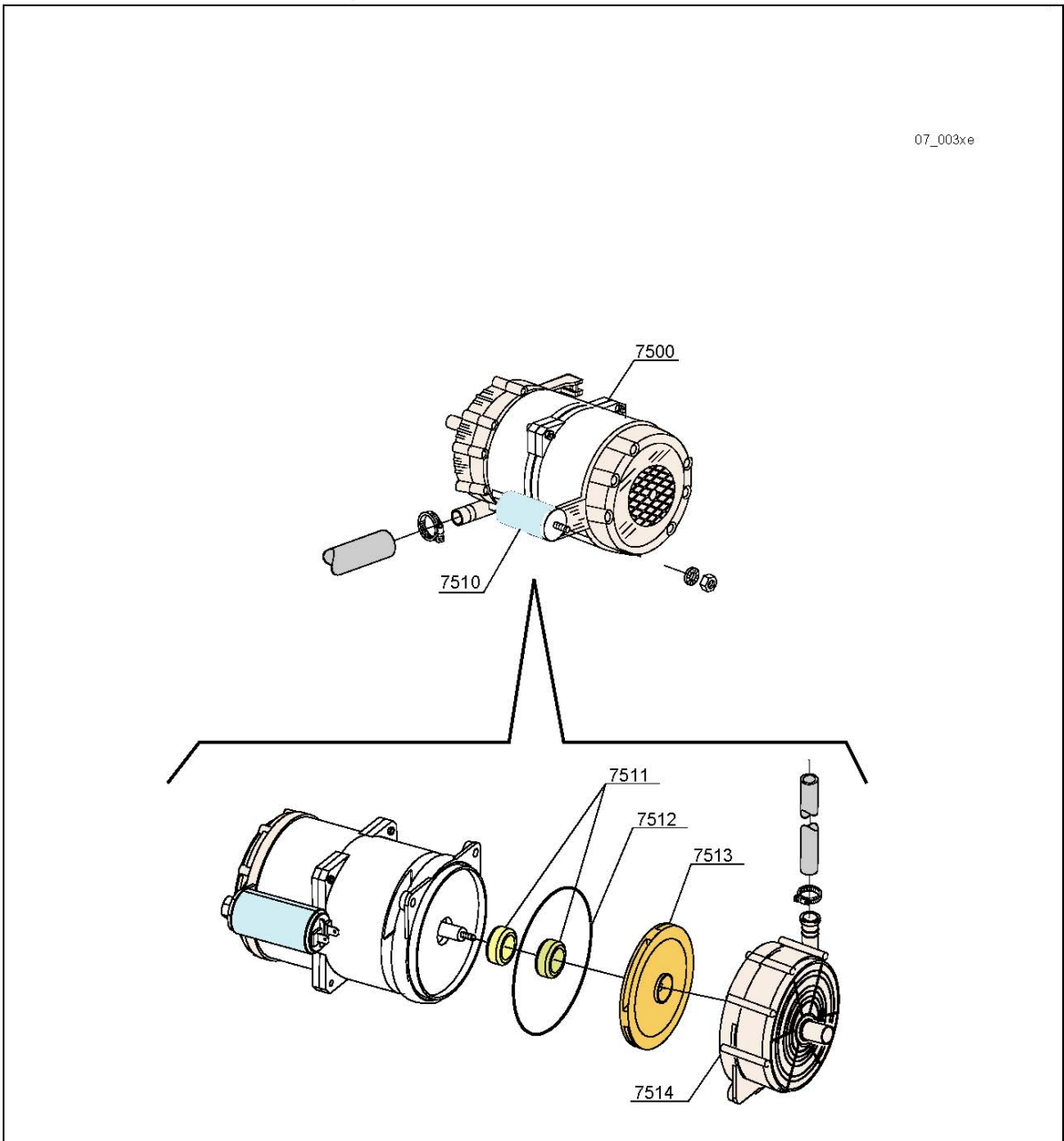

ID	P- Code	DESCRIPTION
7500	2401.89	220/240V 60 Hz Plus Rinsing pump
7510	2401.87	5 uF condenser - 450V
7511	2402.01	Rotating Seals

ID	P- Code	DESCRIPTION
7512	2402.03	O-ring EPDM
7513	2402.05	Pump Rotor
7514	2402.07	Scroll

1.1.11. Rinse Aid Dispenser Group

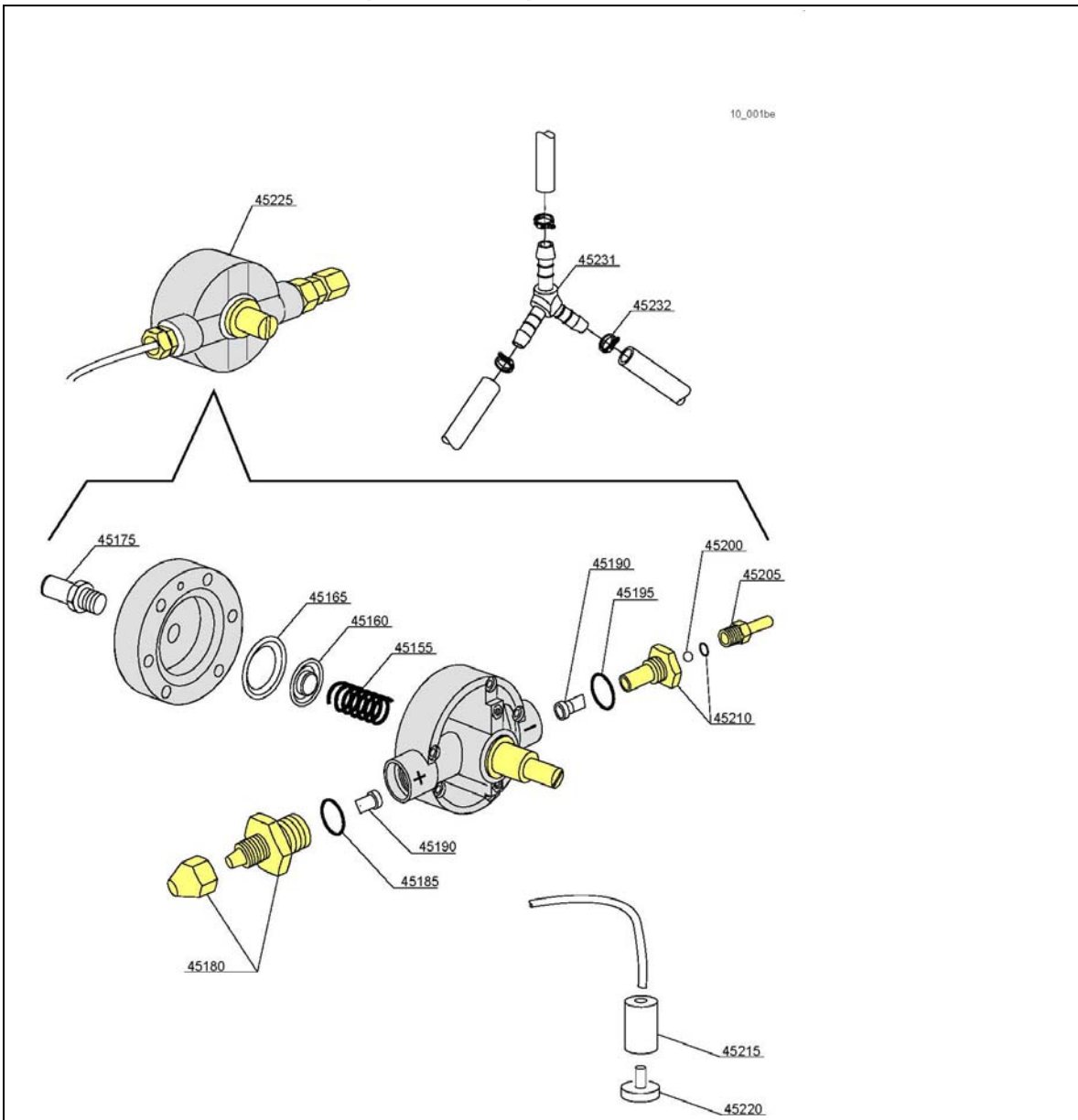

ID	P- Code	DESCRIPTION
45155	2402.41	Spring
45160	2402.43	Membrane Disk
45165	2402.45	Membrane
45175	2402.47	Rubber Holder O 10mm
45180	2402.49	Pipe fitting
45185	2402.51	O-Ring
45190	2402.53	Silicone Valve
45195	2402.51	O-Ring

ID	P- Code	DESCRIPTION
45200	2402.52	Sphere - Teflon
45205	2402.55	Brass Pipe Fitting
45210	2402.57	Guide Valve O-Ring
45215	2101.47	Ballast
45220	2101.48	Small Filter (minimum 3 pieces)
45225	2105.15	GERMAC Rinse Aid Dispenser
45232	2101.42	Clamp 12-22 (minimum 3Pcs)
45233	2402.59	Y Connection 10/12/12

1.1.12. Detergent Dispenser Group

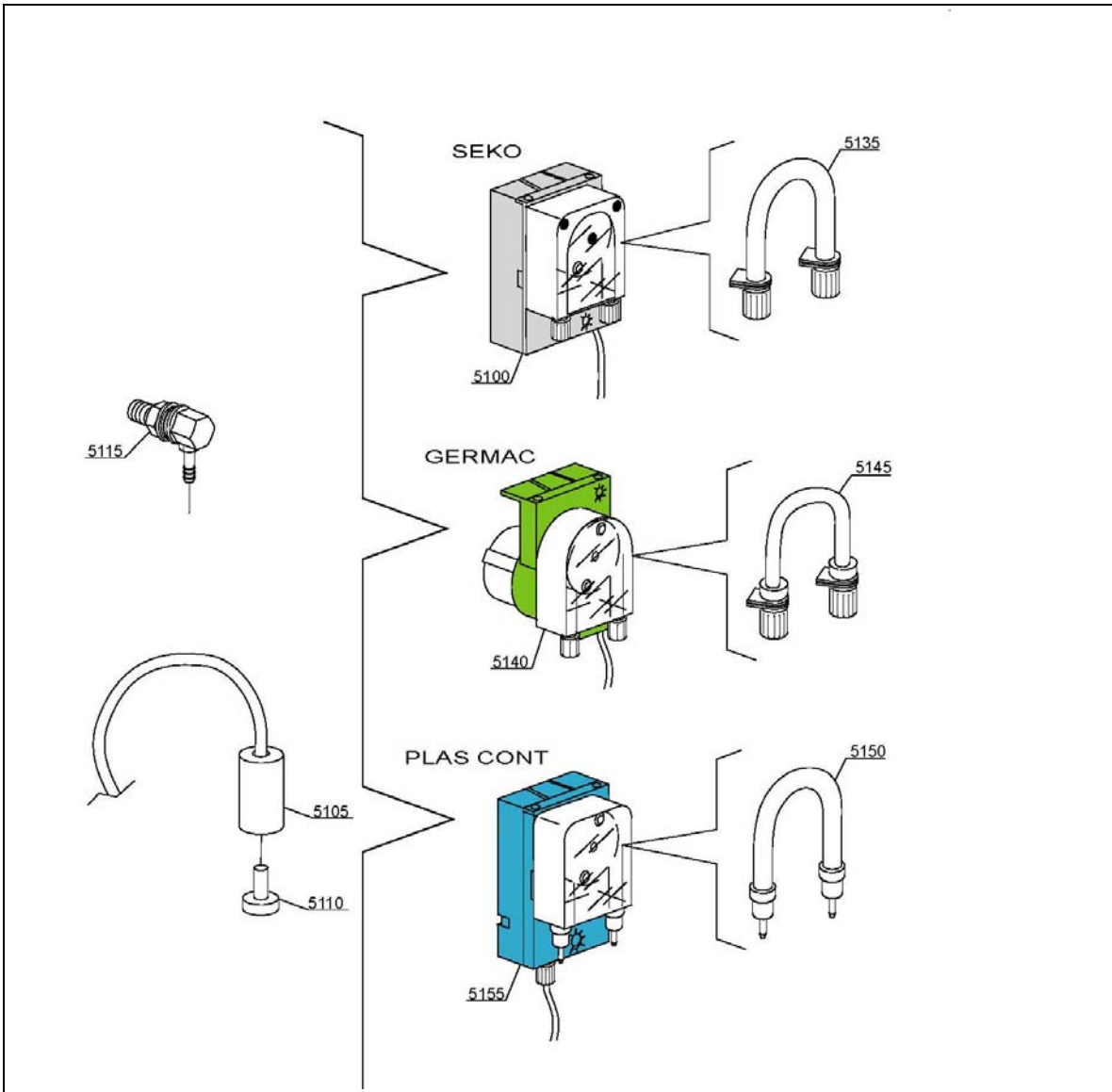

ID	P- Code	DESCRIPTION
5100	2100.19	Detergent pump Seco
5105	2101.47	Ballast
5110	2101.48	Small Filter
5120	2101.02	Complete S/S Injector
5125	2402.81	O-Ring
5130	2402.83	SS Nut M12x1

ID	P- Code	DESCRIPTION
5135	2100.95	Squeeze Tube
5140	2100.19	Detergent Pump
5145	2100.96	Squeeze Tube
5150	2100.97	Squeeze Tube
5155	2100.19	Detergent Pump
5160	2402.85	Detergent Pump - Lang

1.1.13. Heat Recovery

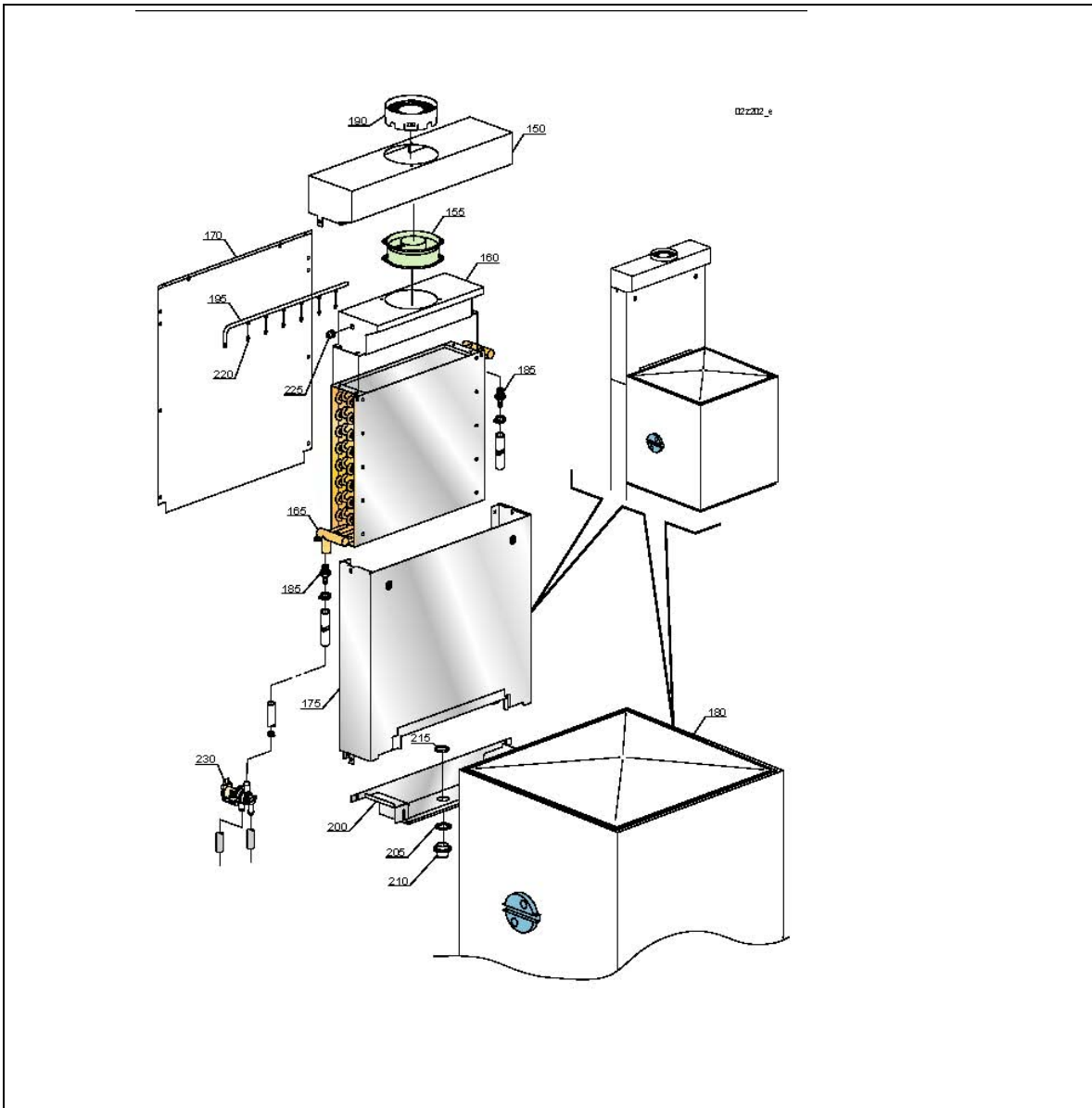

ID	P- Code	DESCRIPTION
150	2400.99	Spoiler
155	2401.01	Motor Fan 230v 50/60hZ
160	2401.03	Fan Support
165	2401.05	Heat Recovery Battery
170	2401.07	Upper Back
175	2401.09	Upper Back Carter
180	2401.11	Hood
185	2401.13	Rubber-Holder 1/2"
190	2401.15	Upper Chimney

ID	P- Code	DESCRIPTION
195	2401.17	Battery Self Cleaning Pipe
200	2401.19	Isolated Hood Trap
205	2401.20	O-Ring 44x32x3
210	2401.21	Drain Fitting
215	2401.23	Drain Nut
220	2101.01	Stainless Steel Rinse Nozzle
225	2401.25	Pipe Gasket
230	2401.27	Valve 230/240v 50/60Hz

1.1.14. Wash Pump

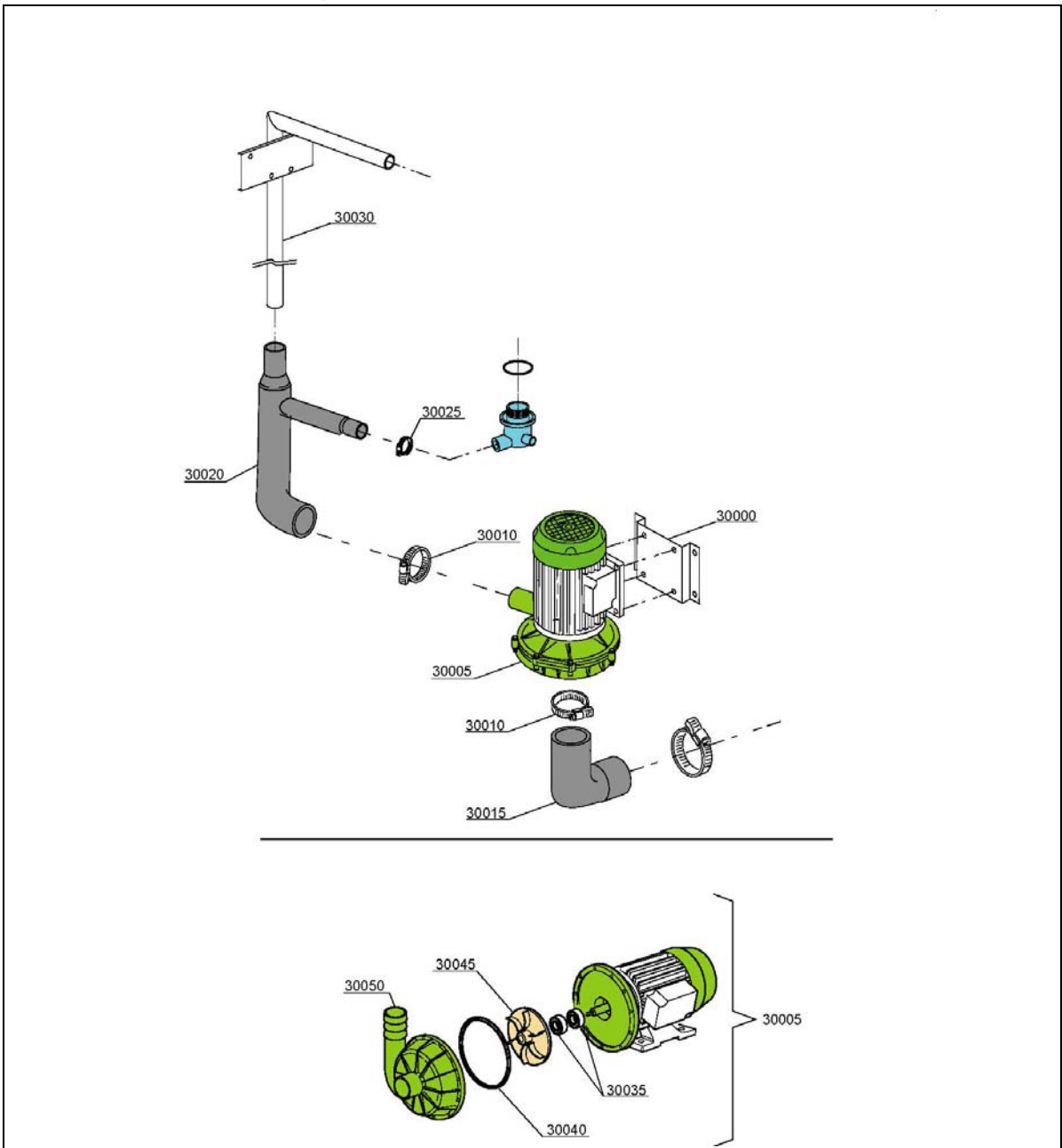

ID	P- Code	DESCRIPTION
3000	2402.63	Pump Base
3000	2402.65	2hp Pump 230/380/415/3p
3000	2402.67	Clamp 30/45
3000	2402.69	Suction Pipe Coupling
3000	2402.71	Pressure Hose - Rubber
3000	2101.55	Clamp 30/45 (minimum 2 pcs)

ID	P- Code	DESCRIPTION
3000	2402.73	Wash Manifold
3000	2101.56	Rotating Seals
3000	2402.75	O-Ring 1225
3000	2402.77	Pump Rotor (2hp Pump)
3000	2402.79	Scroll

1.1.15. Drain pump Group

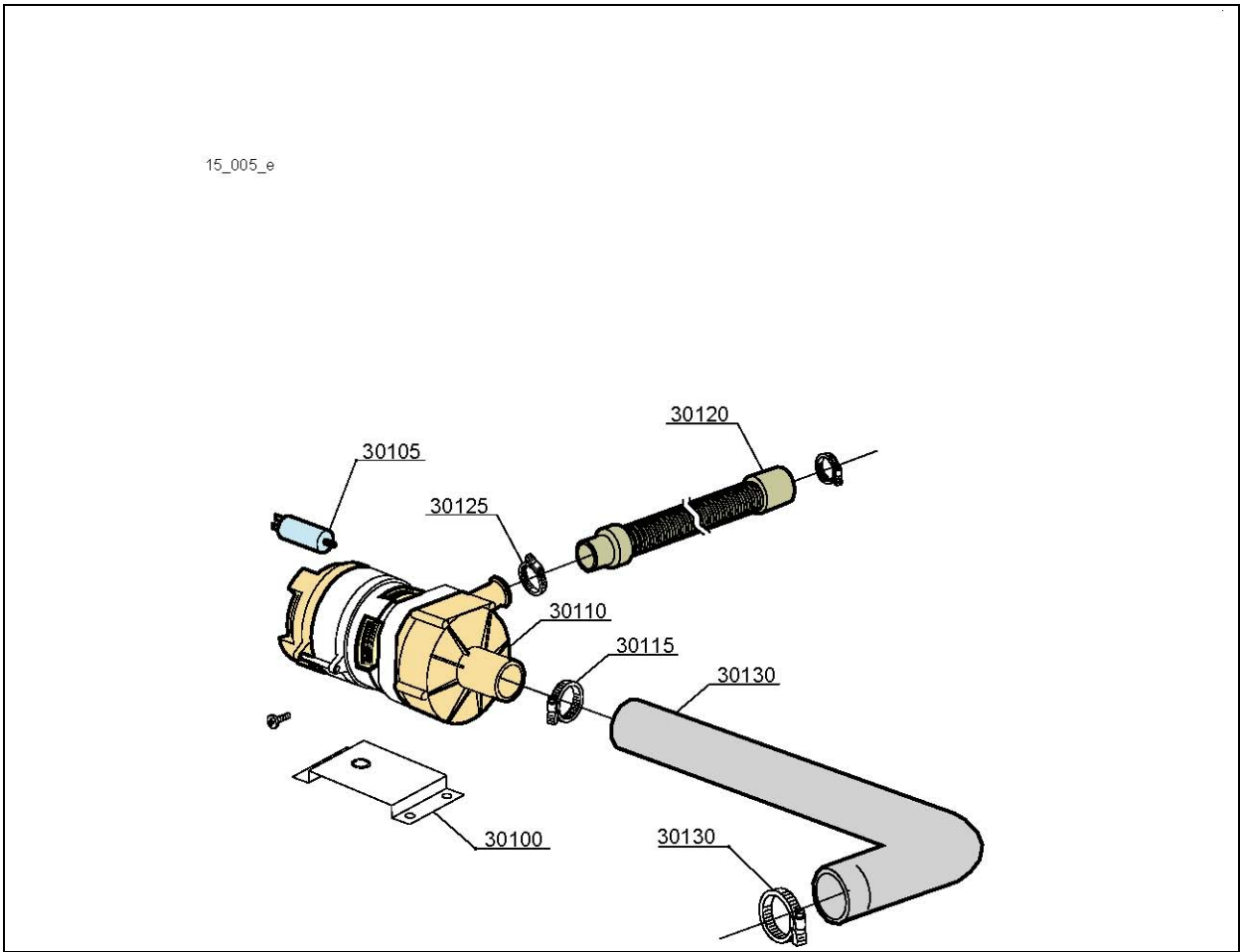

ID	P- Code	DESCRIPTION
30100	2402.87	Pump Support
30100	2401.87	Condenser
30100	2402.89	Booster Pump 220/240v
30100	2101.54	Clamp 25/40 (Minimum 2 pcs)

ID	P- Code	DESCRIPTION
30100	2100.60	Drain Hose
30100	2101.55	Clamp 30/45 (minimum 2 pcs)
30100	2402.91	Drain Elbow - Rubber

1.1.16. Turret Group

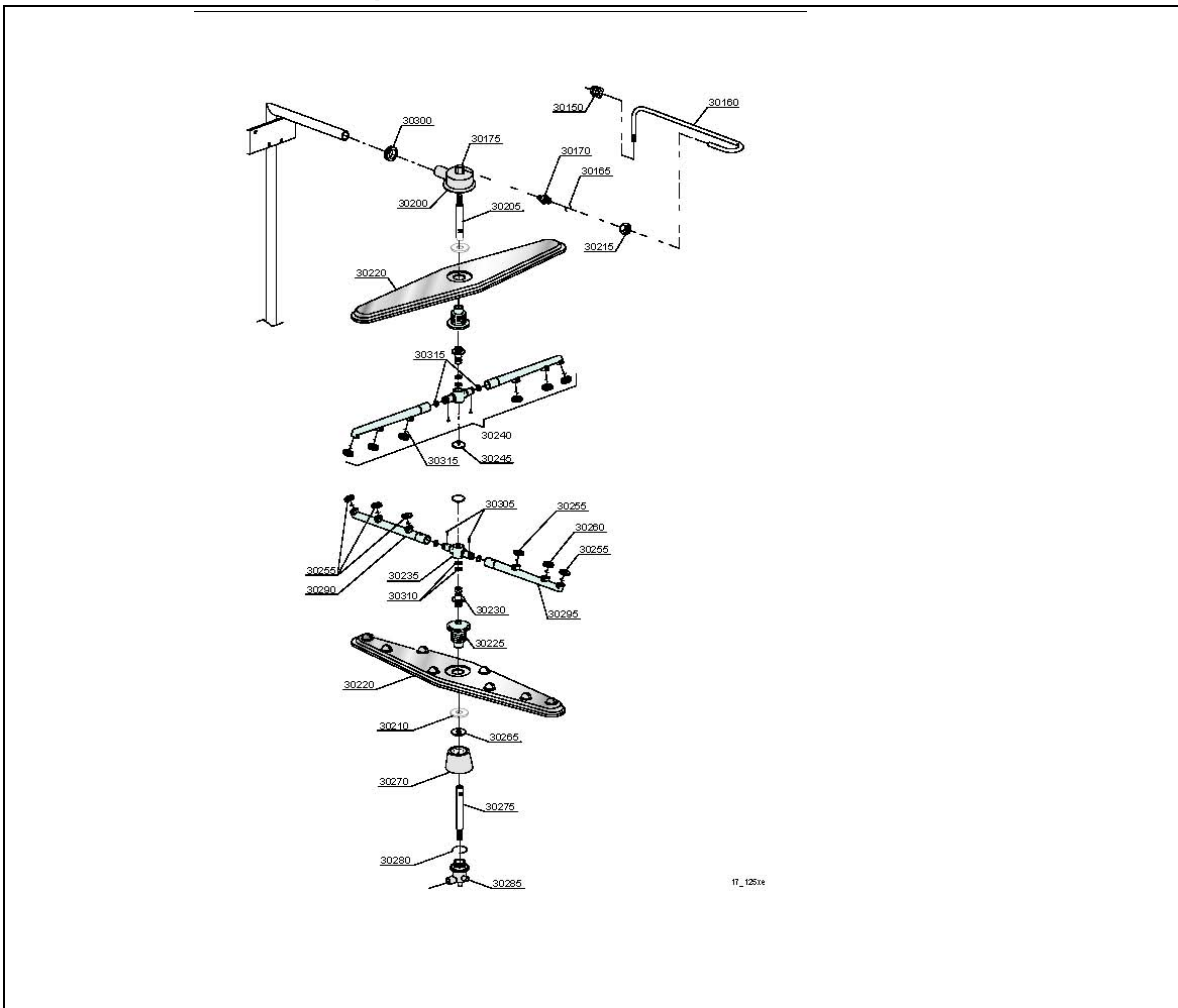

ID	P- Code	DESCRIPTION
30150	2401.25	Pipe Gasket
30160	2402.61	Rinse Pipe
30165	2403.01	O-Ring 112 NBR
30170	2403.03	Coupling
30175	2403.05	Elbow Coupling
30200	2403.07	Distributor - Upper
30205	2403.09	Shaft - Upper
30210	2403.11	Nut
30215	2403.13	Pipe Fitting 3/8x3,5
30220	2403.15	Wash Arm
30225	2403.17	Holder
30230	2101.65	Rinse Axle
30235	2102.12	Hub For Rinse Arm
30240	2403.19	Rinse Arm Complete

ID	P- Code	DESCRIPTION
30245	2101.67	Rinse Arm Screw
30255	<a href="#">2102.15</a>	Open Plastic Rinse Nozzle
30260	2102.16	Closed Plastic Rinse Nozzle
30265	2403.21	Ring
30270	2403.23	Lower Wash Arm Support
30275	2403.25	Shaft - Lower
30280	2403.27	O-Ring
30285	2403.29	Distributor - Lower
30290	<a href="#">2102.13</a>	Right Plastic Rinse Arm
30295	2102.14	Left Plastic Rinse Arm
30300	2403.31	Open Plastic Rinse Nozzle
30305	2102.19	4x10 TCB 8 Spax Toothed Screw
30310	2102.17	O-ring For Hub (Rinse Arm)
30315	2102.18	O-ring R6 NBR