

Cleveland

Service Manual

FREE STANDING GAS SKILLET

MODEL: SGM



Cleveland Range Inc.
1333 East 179th Street
Cleveland, OH 44110

SKI-05

GAS SKILLET OPERATING CONTROLS AND INDICATORS

For your better understanding and confidence, the following explanation of the control system used on these skillets is offered.

Item No.	Description	Function
3	Gas Control Valve (Skillet Bottom Dwg.)	Controls main gas supply to the skillet.
9	Micro (Cut-off) Switch (Skillet Bottom Dwg.)	Protective switch to prevent burners from igniting while skillet is in a tilted position.
5	Thermostat Control Knob (Control Panel Dwg.)	This control knob allows the operator to select various heat increments for operating the skillet.
7	On/Off Toggle Switch (Control Panel Dwg.)	Controls electric power to the skillet.
11	Tilt Switch (Control Panel Dwg.)	When activated, the skillet will tilt forward or back.
12	Operating Pilot Light (Orange) (Control Panel Dwg.)	When illuminated, indicates that the burners are lit.

GAS SKILLET BOTTOM

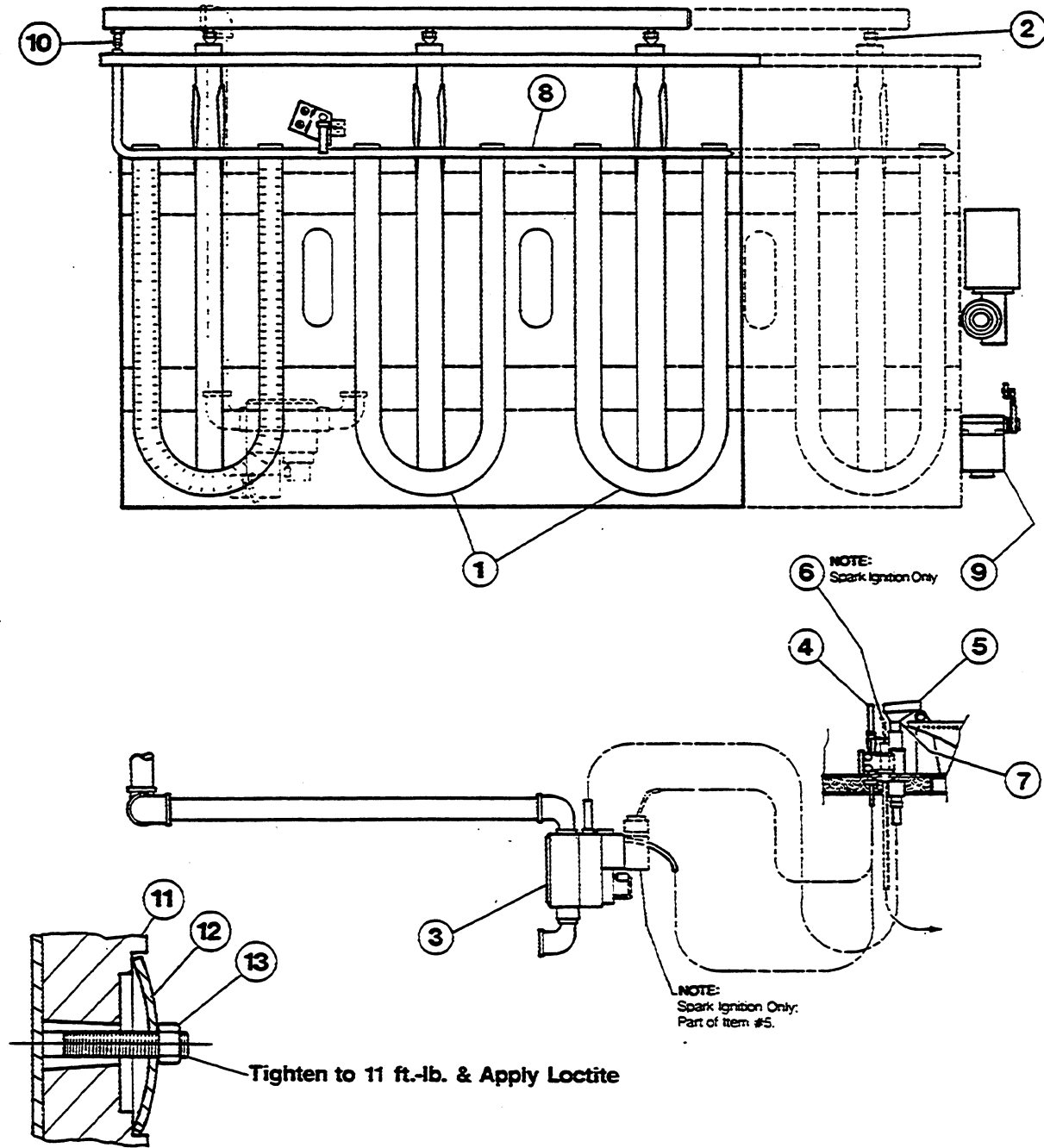

Use only replacement parts which are factory supplied as to preserve the certification of Underwriters Laboratories, American Gas Association, Canadian Standards Association or Canadian Gas Association (as applicable). The use of other than factory supplied replacement parts will void the warranty.

GAS SKILLET BOTTOM

Item No.	Part No.	Description	Qty.
1	SK50337	Burner	3,4
2	SK50341	Orifice, Burner, Nat. Gas (0-2000 ft. elev. #46 drill)	3,4
	SK50343	Orifice, Burner, Nat. Gas (2000-4000 ft. elev. #47 drill)	3,4
	SK50344	Orifice, Burner, Nat. Gas (4000-6000 ft. elev. #48 drill)	3,4
	SK50345	Orifice, Burner, Nat. Gas (6000-8000 ft. elev. #49 drill)	3,4
	SK50342	Orifice, Burner, L.P. (0-2000 ft. elev. #54 drill)	3,4
	SK50346	Orifice, Burner, L.P. (2000-4000 ft. elev. #55 drill)	3,4
	SK50347	Orifice, Burner, L.P. (4000-6000 ft. elev. #56 drill)	3,4
	SK50348	Orifice, Burner, L.P. (6000-8000 ft. elev. #57 drill)	3,4
3	KE51155	Combination Gas Control Valve, Nat. Gas, 24 VAC (Spark Ignition)	1
	KE51163	Combination Gas Control Valve, L.P., 24 VAC (Spark Ignition)	1
	KE51110	Combination Gas Control Valve, Nat. Gas, 120 VAC (Manual Ignition)	1
	KE51161	Combination Gas Control Valve, L.P., 120 VAC (Manual Ignition)	1
4	KE51111	Pilot Flame Sensor (Thermopile Type) (Manual Ignition)	1
	KE51159	Pilot Flame Sensor (Mercury Vapor Type) (Spark Ignition)	1
5	KE51114	Pilot Burner	1
6	KE01018	Ignition Electrode (Spark Ignition)	1
7	KE51116	Orifice, Pilot, Nat. Gas (.020")	1
	KE51162	Orifice, Pilot, L.P. (.0145")	1
8	SK50334	Zip Tube (SGM-30)	1
	SK50335	Zip Tube (SGM-40)	1
9	SK50373	Micro (cut-off) Switch	1
10	SK50363	Orifice, Zip Tube, Nat. Gas, #61 drill	1
	SK50364	Orifice, Zip Tube, L.P., #72 drill	1
11	SK50252	Heat Spreader (R.H. End Piece)	1
	SK50249	Heat Spreader (L.H. End Piece)	1
	SK50253	Heat Spreader (With Thermostat Cut-out)	1
	SK50213	Heat Spreader (Plain)	3,5
12	SK50416	Washer, Spherical	28,36
13	FA21024	Nut, 5/16-18	28,36

GAS SKILLET CONTROL PANEL

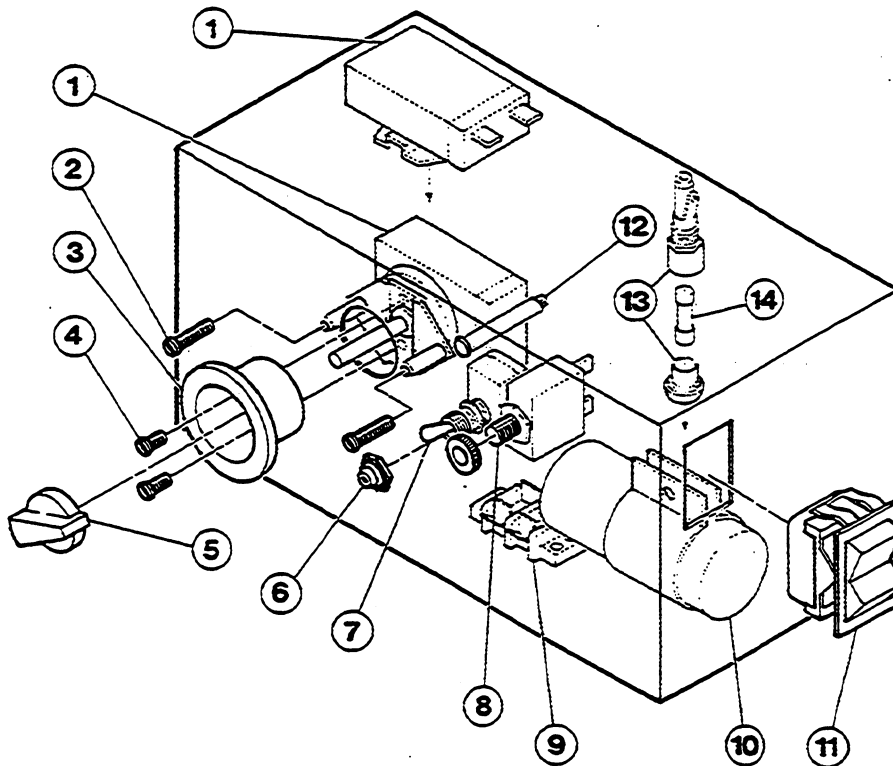

Item No.	Part No.	Description	Qty.
1	KE55069-2	Thermostat, Control / Safety	2
2	FA10140	Screw, Thermostat, 6-32 x 1 1/4"	2
3	SK00031	Bezel	1
4	FA10135	Screw, Bezel, 6-32 x 5/8"	2
5	SK50059	Knob, Thermostat	1
6	SK50062	Rubber Boot	1
7	KE50504	Switch, Toggle, On/Off, SPST (115V Units)	1
	SK50056	Switch, Toggle, On/Off, DPST (208-240V Units)	1
8	SK50208	Circuit Breaker, 3 Amp	1
9	SK50370	Terminal Block, 2 Pole	1
10	KE51386	Capacitor, 27-32 MFD	1
11	SK50175	Switch, Rocker, Momentary	1
12	SK50315	Pilot Light	1
13	SK50371	Fuse Holder (manual ignition only)	1
14	KE51140	Fuse, 4/10 Amp (manual ignition only)	1

Use only replacement parts which are factory supplied as to preserve the certification of Underwriters Laboratories, American Gas Association, Canadian Standards Association or Canadian Gas Association (as applicable). The use of other than factory supplied replacement parts will void the warranty.

GAS SKILLET SPARK IGNITION

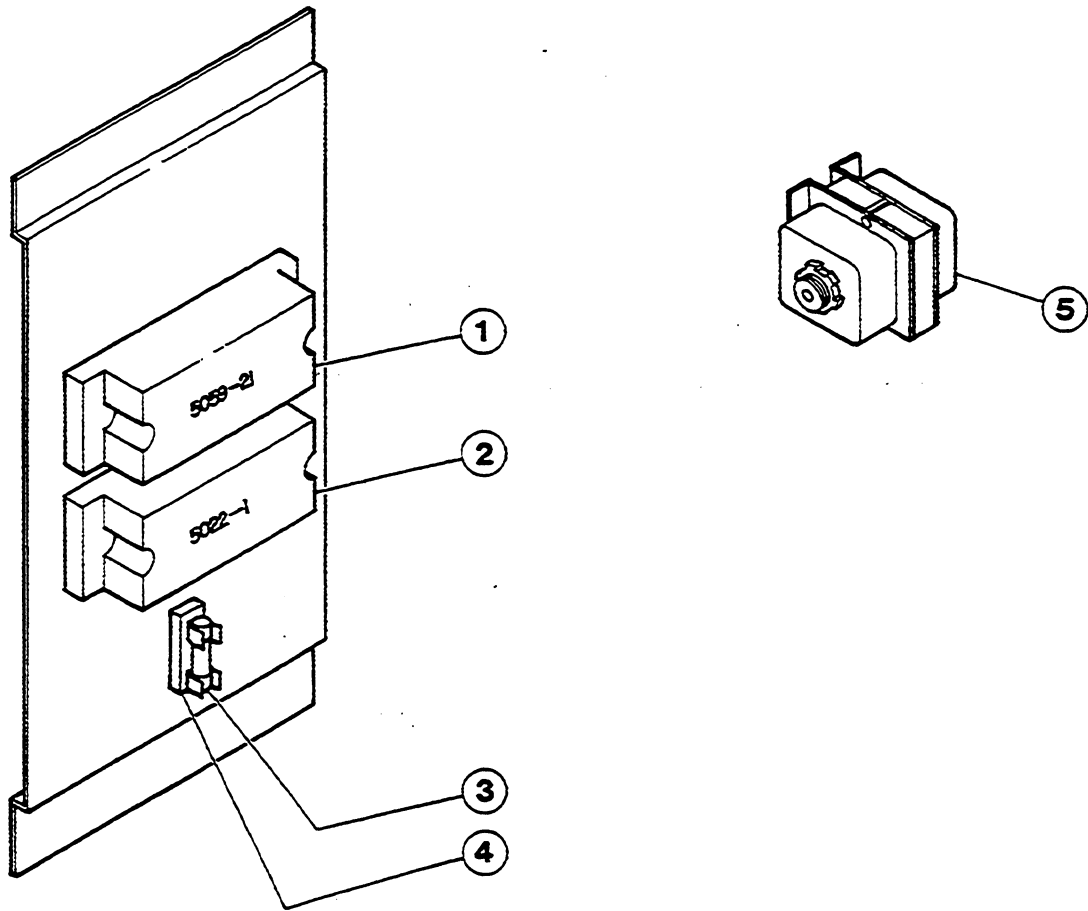

Item No.	Part No.	Description	Qty.
1	KE51167	Pilot Re-Lite (see note*)	1
2	KE51168	Cycling Pilot Safety Timer (L.P. only) (see note*)	1
3	KE51169	Fuse, 1½ Amp	1
4	KE51139	Fuse Holder	1
5	KE51164	Transformer - 120/24V	1

*Note: Pilot Re-Lite and Cycling Pilot Safety Timer may be combined as one control.
Cat. No. 50A22-1, Cleveland Part No. KE51405.

Use only replacement parts which are factory supplied as to preserve the certification of Underwriters Laboratories, American Gas Association, Canadian Standards Association or Canadian Gas Association (as applicable). The use of other than factory supplied replacement parts will void the warranty.

GAS SKILLET POWER JACK ASSEMBLY

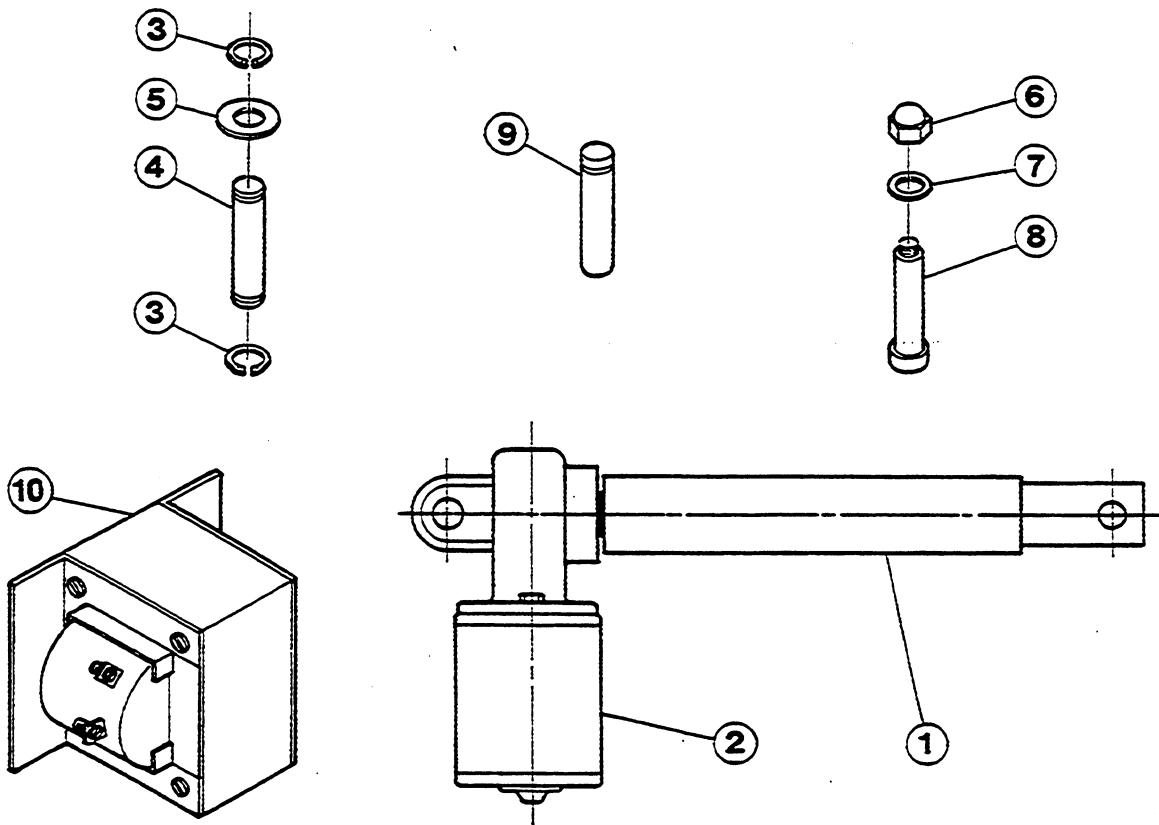

Item No.	Part No.	Description	Qty.
1-2	SK50314	Complete Power Jack	1
2	SE50025	Motor, Power Jack	1
3	SK50377	Retaining Ring	2
4	SK50376	Pin, Bottom Jack Mounting	1
5	SK50425	Washer, 17/32" ID, 1-1/16" OD	1
6	SK50368	Acorn Nut, 5/16 - 18	1
7	SK50367	Washer, 25/64" ID, 5/8" OD	1
8	SK50256	Pin, Upper Jack Mounting	1
9	SK50376-B	Pin, Bottom Jack Mounting	1
10	SK50221	Transformer - 208/120V (208V units)	1
	SK50264	Transformer - 240/120V (220-240V units)	1

Use only replacement parts which are factory supplied as to preserve the certification of Underwriters Laboratories, American Gas Association, Canadian Standards Association or Canadian Gas Association (as applicable). The use of other than factory supplied replacement parts will void the warranty.

SKILLET HINGE ASSEMBLY

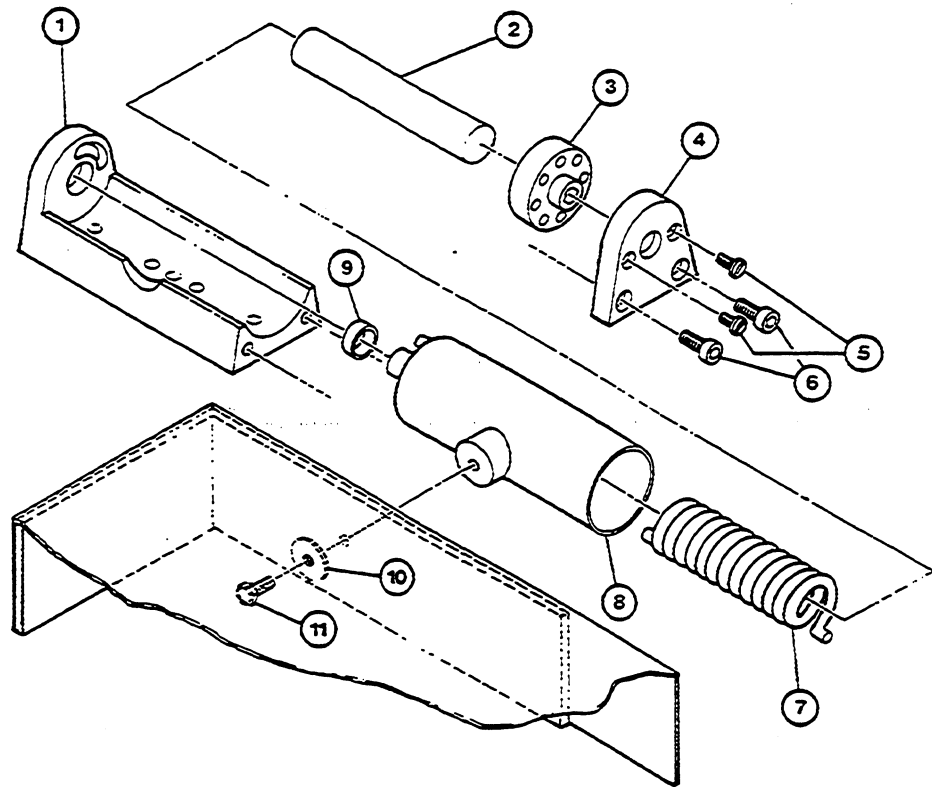

Item No.	Part No.	Description	Qty.
1-9	KE00598	Hinge Assy. (30 Gal.)	2
	SK00168	Hinge Assy. (40 Gal.)	2
1	KE51218	Body, Hinge	1
2	KE50823	Pin, Hinge	1
3	KE50820	Insert, Hinge	1
4	KE50819	End Piece, Hinge	1
5	FA11507	Screw, Tension Adjust, 10-24 x 3/4"	2
6	FA11284	Screw, End Piece, 1/4-20 x 1/2"	2
7	KE50122	Spring, Hinge (30 Gal.)	1
	KE50121	Spring, Hinge (40 Gal.)	1
8	KE51217	Cylinder, Hinge	1
9	KE50824	Bearing, Hinge	1
10	SK50209	Washer	1
11	SK00101	Bolt, 3/8-16 x 1"	1

Use only replacement parts which are factory supplied as to preserve the certification of Underwriters Laboratories, American Gas Association, Canadian Standards Association or Canadian Gas Association (as applicable). The use of other than factory supplied replacement parts will void the warranty.

KETTLE AND SKILLET FAUCET

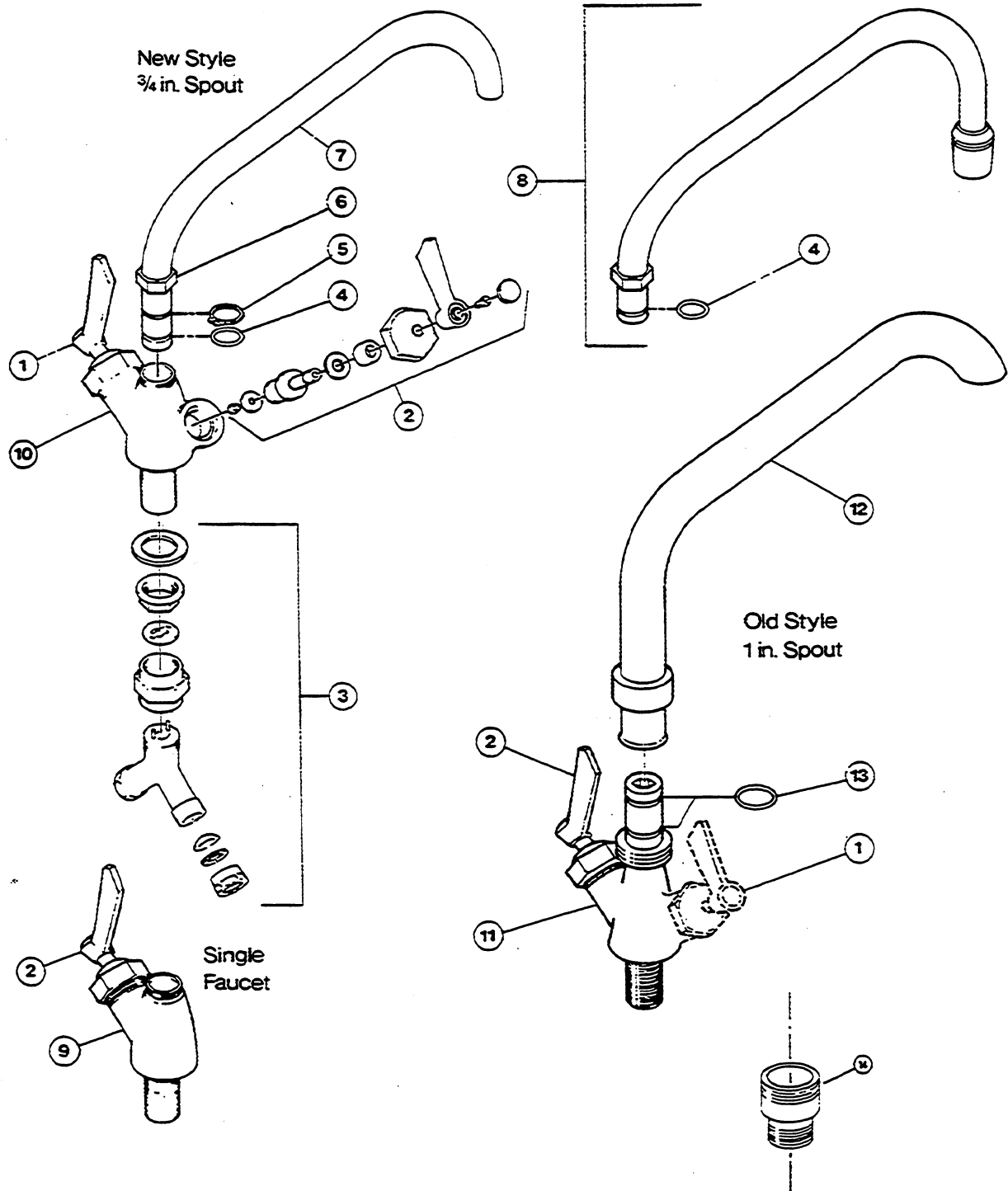

KETTLE AND SKILLET FAUCET

Item No.	Part No.	Description	Qty.
1	SE50020	Hot Water Stem Assy.	1
2	SE50021	Cold Water Stem Assy.	1
3	SE50022	Yoke Connection Kit	1
4	FA00016	"O" Ring	1
5	FA95022	Retaining Ring	1
6	KE51404	Spout Nut	1
7	see chart	¾" spout (please see ¾" spout chart below)	1
8	N/A	¾" spout with Aerator (please order Item No. 4.5.6.7)	1
9	KE51401	Single Pantry Control Valve (incl. Item No. 2)	1
10	KE51403	Double Pantry Control Valve (incl. Item No. 1,2,3)	1
11	N/A	Old Style Single Pantry Control Valve (please order Item No. 4.5.6,7,9)	1
	N/A	Old Style Double Pantry Control Valve (please order Item No. 4.5.6,7,10)	1
12	N/A	1" Spout (please order Item No. 4.5.6,7,14)	1
13	FA00115	"O" Ring	2
14	SE50061	Adapter (to adapt new style spout to old style control valve)	1

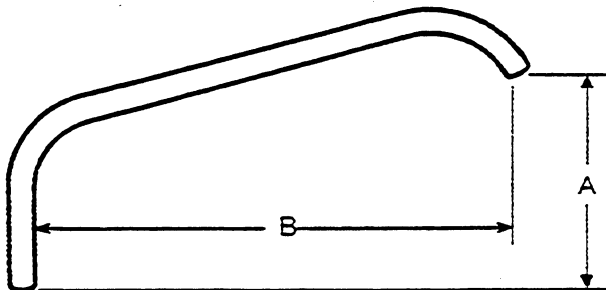

A	B	Part No.
4"	8"	KE50833
10"	9"	KE50832
6"	22"	KE50831
12½"	14"	KE50830
10¾"	14"	KE50829
5"	14"	KE50828
24"	9"	KE50827
20"	9"	KE50826
12½"	9"	KE50825

Use only replacement parts which are factory supplied as to preserve the certification of Underwriters Laboratories, American Gas Association, Canadian Standards Association or Canadian Gas Association (as applicable). The use of other than factory supplied replacement parts will void the warranty.

FLOOR MODEL SKILLET COVER VENT CAP AND DEFLECTOR

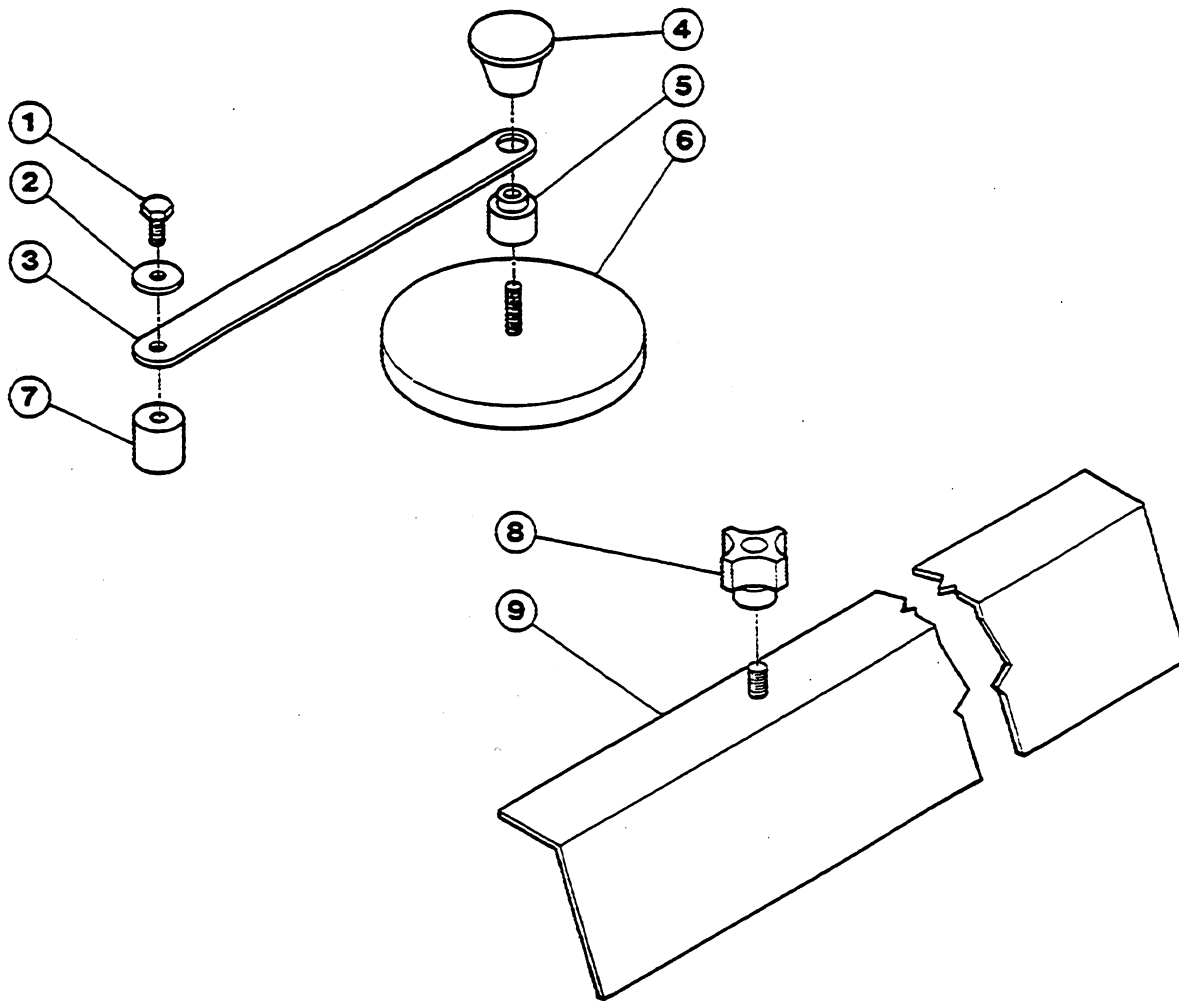

Item No.	Part No.	Description	Qty.
1	SK00105	Screw, ¼-20 x ¾"	1
2	SK50179	Washer	1
3-6	SK00054	Vent Cap Assy.	1
3	SK51032	Support Arm	1
4	SK50218	Knob	1
5	SK50131	Spacer	1
6	SK00059	Cover	1
7	SK50133	Spacer	1
8	SK50444	Knob	*3, 4
9	SK00175	Deflector Assy. (30 Gal.)	1
	SK00176	Deflector Assy. (40 Gal.)	1

*The first figure represents the 30 gallon model and the second figure represents the 40 gallon model.

Use only replacement parts which are factory supplied as to preserve the certification of Underwriters Laboratories, American Gas Association, Canadian Standards Association or Canadian Gas Association (as applicable). The use of other than factory supplied replacement parts will void the warranty.

SERVICING GUIDE

This section contains servicing information intended for use by Authorized Service Personnel.

A/ Problem: Skillet is not heating at all. (Skillet must be on, thermostat control set, and in a down position)

Possible Causes

- | | |
|---|--|
| 1. No power – either gas or electric. | 8. Defective pilot flame sensor. |
| 2. Micro (cut-off) switch faulty or not activated (skillet in a tilted position). | 9. Defective pilot re-light. (Spark ignition) |
| 3. Defective on/off switch. | 10. Defective cycling pilot safety timer. (Spark ignition) |
| 4. Defective control thermostat. | 11. Defective or incorrectly adjusted gas control valve. |
| 5. Defective safety thermostat. | 12. Blown 4/10 or 1½ amp fuse. |
| 6. Defective 208-240/120 VAC transformer. (208-240V units) | 13. Incorrect spark gap. (Spark ignition) |
| 7. Defective 120/25 VAC transformer. (Spark ignition) | 14. Poor ground. |
| | 15. Faulty wiring. |

Fault Isolation Procedure

Step	Test	Result	Remedy
1.	Are both electrical and gas supplies available to unit?	Yes	Go to step #2.
		No	Correct external power supply problem.
2.	Is the operating pilot light illuminated?	Yes	Go to step #8.
		No	Go to step #3.
3.	Will the skillet tilt?	Yes	Go to step #5.
		No	Go to step #4.
4.	On 208-240V units, is there 208-240 VAC present at input of 208-240/120 VAC transformer? On 120V units, Follow Accessing Control Panel Procedure and replace defective on/off switch.	Yes	Replace defective 208-240/120 VAC transformer.
		No	Follow Accessing Control Panel Procedure and replace defective on/off switch.
5.	On manual ignition skillets, is the 4/10 amp fuse open circuited? On spark ignition, go to step #6.	Yes	Replace blown 4/10 amp fuse
		No.	Go to step #6.
6.	Follow Accessing Control Panel Procedure. Measure continuity across control thermostat. Is it an open circuit?	Yes	Replace defective control thermostat.
		No	Go to step #7.
7.	Measure continuity across safety thermostat. Is it an open circuit?	Yes	Replace defective safety thermostat
		No	Replace defective micro (cut-off) switch.
8.	It is assumed that there is proper operating incoming gas pressure of minimum 7" W.C. for natural gas and 12" W.C. for LP gas. For manual ignition, go to step #9. For spark ignition natural gas, go to step #11. For spark ignition LP gas, go to step #18.		

9.	Can a pilot flame be achieved?	Yes	Refer to Pilot Flame Adjustment Procedure and adjust flame if necessary. If adjustment is not required or unsuccessful, go to step #10.
		No	Replace defective gas control valve.
10.	Does the pilot flame sensor (thermopile) generate 450-750 mV?	Yes	Replace defective gas control valve.
		No	Replace defective pilot flame sensor.
11.	Look through peep hole. Can a pilot flame be achieved?	Yes	Go to step #16.
		No	Go to step #12.
12.	Is a spark being generated?	Yes	Go to step #17.
		No	Go to step #13.
13.	Is the 1½ amp fuse open circuited?	Yes	Replace blown 1½ amp fuse.
		No	Go to step #14.
14.	Is there 25 VAC present at output of 120/25 VAC transformer?	Yes	Go to step #15.
		No	Replace defective 120/25 VAC transformer.
15.	Is the spark gap 1/8" ± 1/32"?	Yes	Replace defective pilot re-light.
		No	Adjust spark gap.
16.	After pilot has been lit for 5 minutes, pull pilot flame sensor's connection off and quickly measure continuity between pins #2 and #4. Is it a closed circuit at first and after pilot flame sensor cools down the circuit opens?	Yes	Replace defective gas control valve.
		No	Refer to Pilot Flame Adjustment Procedure and adjust flame if necessary. If adjustment is not required or unsuccessful, replace defective pilot flame sensor.
17.	Measure continuity across pilot flame sensor's pins #3 and #4. Is it a closed circuit?	Yes	Replace defective gas control valve.
		No	Replace defective pilot flame sensor.
18.	Look through peep hole. Is a spark being generated?	Yes	Go to step #22.
		No	Go to step #19.
19.	Is the 1½ amp fuse open circuited?	Yes	Replace blown 1½ amp fuse.
		No	Go to step #20.
20.	Is there 25 VAC present at output of 120/25 VAC transformer?	Yes	Go to step #21.
		No	Replace defective 120/25 VAC transformer.
21.	Is the spark gap 1/8" ± 1/32"?	Yes	Replace defective pilot re-light.
		No	Adjust spark gap.
22.	Turn power on/off switch to "off" for 5 minutes. This will zero the cycling pilot safety timer. Then turn unit back on. Is a pilot flame available?	Yes	If burners now fail to ignite, go to step #24.
		No	Go to step #23.
23.	Measure continuity across pilot flame sensor's pins #3 and #4. Is it a closed circuit?	Yes	Replace either defective cycling pilot safety timer or gas control valve. (Note: Gas control valve would be the more reliable component.)
		No	Replace defective pilot flame sensor.

- | | | | |
|-----|---|-----|---|
| 24. | After pilot has been lit and just as pilot goes out due to cycling pilot safety timer, pull pilot flame sensor's connection off and quickly measure continuity between pins #2 and #4. Is it a closed circuit at first and after pilot flame sensor cools down the circuit opens? | Yes | Replace defective gas control valve. |
| | | No | Refer to Pilot Flame Adjustment Procedure and adjust flame if necessary. If adjustment is not required or unsuccessful, replace defective pilot flame sensor. |

B/ Problem: Skillet heats too slowly or not hot enough.
 (Note: Maximum surface temp. is 425°F)

Possible Causes

1. Low incoming gas pressure.
2. Defective or incorrectly adjusted gas control valve.
3. Defective or incorrectly adjusted control thermostat.
4. Defective or incorrectly adjusted safety thermostat.

Fault Isolation Procedure

<u>Step</u>	<u>Test</u>	<u>Result</u>	<u>Remedy</u>
1.	Tilt skillet fully forward and manually activate the tilt safety switch. Inspect the burner flame for a period of 4 or 5 minutes. Is the burner flame strong and constant?	Yes	Go to step #3.
		No	Go to step #2.
2.	There is a <u>operating</u> gas supply problem, either incoming or outgoing. Refer to Pilot Flame Adjustment and Gas Pressure Adjustment Procedure. If this does not correct the problem, check incoming <u>operating</u> gas supply. It should be minimum 7" W.C. natural gas or 12" W.C. LP gas. If gas pressure is correct, replace defective gas control valve. *		
3.	In an operating situation and with control thermostat set at #10, do the burners shut off too early?	Yes	Go to step #4.
		No	Go to step #2.
4.	Immediately after burners have shut off, turn control thermostat back to #1. Can you hear or feel the thermostat "clicking" off?	Yes	Adjust or replace safety thermostat. (adjust to approx. 470°F)
		No	Adjust or replace control thermostat. (adjust to approx. 425°F)

C/ Problem: Skillet is overheating.

Replace or adjust control thermostat. (adjust to approx. 425°F) Verify that safety thermostat shuts off at approx. 470°F. To replace either thermostat, follow Accessing Control Panel Procedure.

D/ Problem: Skillet fails to tilt. (Note: A thermal overload in jack motor does not allow constant consecutive tilting.)

Possible Causes

- | | |
|--|--|
| 1. No electrical power to the skillet. | 5. Defective ON/OFF switch. |
| 2. Circuit breaker tripped or defective. | 6. Defective 208-240/120 VAC transformer (208-240V units). |
| 3. Defective rocker (up - down) switch. | 7. Defective power jack. |
| 4. Defective start capacitor. | |

Fault Isolation Procedure

<u>Step</u>	<u>Test</u>	<u>Result</u>	<u>Remedy</u>
1.	Verify that the 3 amp circuit breaker has not tripped by pressing in on the reset button. Is there proper incoming voltage to the skillet?	Yes	Go to step #2.
		No	Correct external power supply problem.
2.	On 120V units go to step #4. On 208-240V units, is there 208-240 VAC present at input of 208-240/120 VAC transformer?	Yes	Go to step #3.
		No	Replace defective on/off switch.
3.	Is there 120 VAC present at output of 208-240/120 VAC transformer?	Yes	Go to step #4.
		No	Replace defective 208-240 VAC transformer.
4.	Remove motor from power jack. Activate tilt switch. Does the motor rotate?	Yes	Replace defective power jack. Follow Power Jack Removal Procedure.
		No	Go to step #5.
5.	Follow Accessing Control Panel Procedure, and if necessary, Power Jack Removal Procedure. Go to step #6.		
6.	Test rocker switch for continuity. Is it operating properly?	Yes	Go to step #7.
		No	Replace defective rocker switch.
7.	Test ON/OFF switch for continuity. Is it operating properly?	Yes	Go to step #8.
		No	Replace defective ON/OFF switch.
8.	Is the 3 amp circuit breaker open circuited?	Yes	Replace defective circuit breaker.
		No	Go to step #9.
9.	Remove power jack wiring from connections. Measure resistance across each of the three wires. Do they read (approx.): 14 ohms between black and white, 29 ohms between black and red, and 14 ohms between red and white?	Yes	Replace defective start capacitor.
		No	Replace defective motor or power jack.

GAS PRESSURE ADJUSTMENT PROCEDURE

CAUTION: The following procedure, as well as other work on gas controls should be performed only by a qualified service technician.

NOTE: Gas pressure adjustment is pre-set and rarely needs any adjustment.

1. Remove gas pressure adjustment cover screw.
2. Operating gas pressure output should be regulated to 6" W.C. natural gas and 11" W.C. LP gas.
3. Turn gas pressure adjustment screw (under cover screw) clockwise to increase or counterclockwise to decrease gas pressure.
4. Replace cover screw.

PILOT FLAME ADJUSTMENT PROCEDURE

CAUTION: The following procedure, as well as all other work on gas controls should be performed only by a qualified service technician.

1. Remove pilot adjustment cover screw.
2. Turn pilot flow adjustment screw (under cover screw) clockwise to increase flame (see below drawing for correct flame adjustment).
3. Replace cover screw.

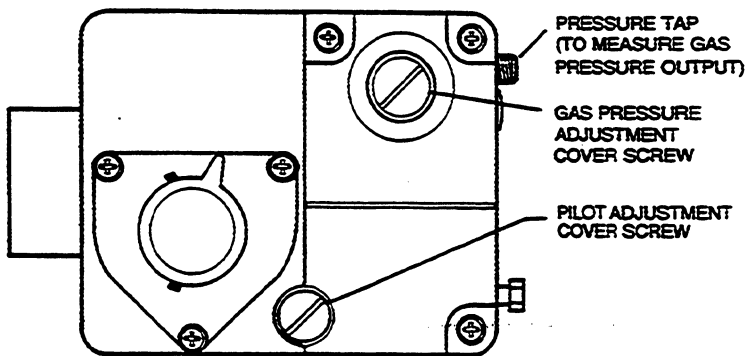

COMBINATION CONTROL VALVE

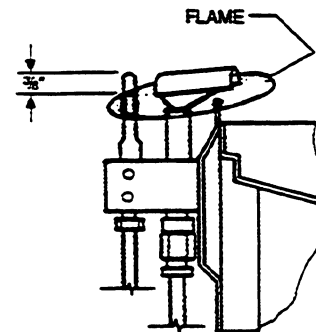

PILOT GENERATOR

ACCESSING CONTROL PANEL PROCEDURE

1. Tilt skillet fully forward.
(note: if skillet cannot be tilted forward, go to problem D)
2. Turn off power switch.
3. Remove burners and zip tube.
(they are simply clipped in)
4. If spark ignition, remove 2 screws holding ignition electrode to pilot burner.
5. Remove 2 screws holding pilot burner to bracket.
6. Drop ignition electrode and pilot burner through hole in burner box insulation cover.
7. Remove 5 screws/bolts holding burner box insulation cover.
8. Remove insulation cover from unit.
9. Remove 2 screws on control panel box cover.
10. Remove control panel box cover.
11. Reverse steps to re-assemble.

POWER JACK REMOVAL PROCEDURE

WARNING: Skillet pan is heavy and support should always be given to pan if jack is being removed.

Refer to correct diagram and follow procedure required.

PROCEDURE #1

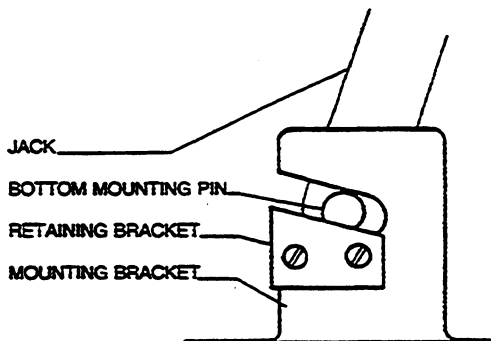

1. Remove two screws holding pin retaining bracket.
2. Remove bottom mounting pin.
3. Remove acorn nut from top mounting pin.
4. Lift and support skillet pan to allow jack to clear bottom mounting bracket.
5. Remove jack from top mounting pin.
6. Reverse steps to re-assemble.

PROCEDURE #2

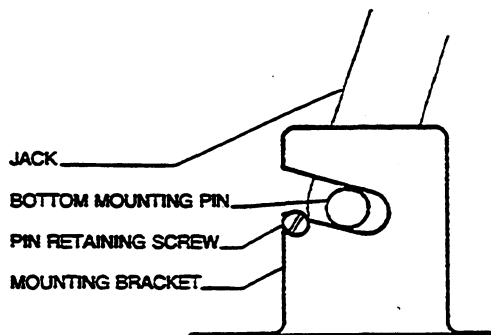

1. Tilt skillet fully forward. If skillet cannot be tilted fully forward go to step #2, otherwise go to step #4.
2. Remove motor from jack.
3. Using a reverse drill, "unscrew" the jack gear shaft. This will tilt the skillet forward.
4. Remove pin retaining screw from bottom mounting bracket.
5. Remove acorn nut from top mounting pin.
6. Unscrew protective collar enclosing jack arm and lift collar above skillet frame.
7. Remove jack from top mounting pin.
8. Remove jack from bottom mounting bracket.
9. Screw jack arm back down for easier removal.
10. Reverse steps to re-assemble.

PROCEDURE #3

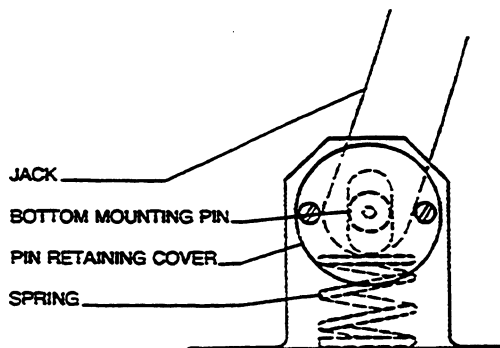

1. Remove two screws holding pin retaining cover and remove cover.
2. Thread one of the cover screws (#10-24) into the end of the bottom mounting pin. (note: screw will probably be damaged pulling out pin)
3. Locate the mounting pin in approximately the middle of the brackets mounting hole. Downward pressure on the skillet pan may have to be applied.
4. Remove pin by pulling out on screw.
5. Remove acorn nut from top mounting pin.
6. Remove jack from top mounting pin.
7. Reverse steps to re-assemble.

HINGE ADJUSTMENT INSTRUCTIONS

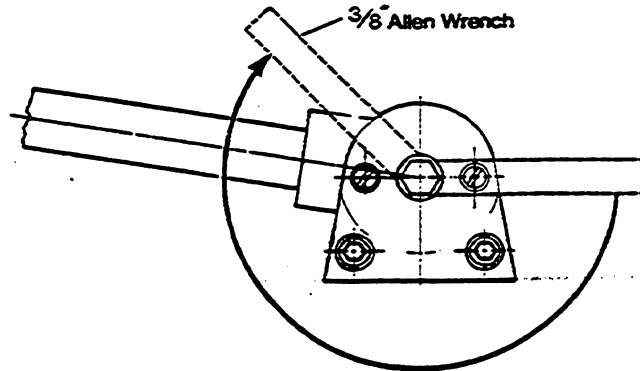

1. Insert $\frac{3}{8}$ " Allen wrench.
2. Turn clockwise to relieve tension on spring.
3. While tension is released remove one of the two slotted screws.
4. To prevent Allen wrench from springing back abruptly while the second slotted screw is removed, insert a pin (approximately $\frac{1}{8}$ ") in the hole where the first slotted screw was removed from.
5. Remove second slotted screw.
6. While holding Allen wrench remove pin.
7. Turn Allen wrench clockwise to tighten or counter-clockwise to loosen tension to produce desired effect.
8. Re-insert pin in one of the two holes.
9. Tighten one slotted screw in the other hole (it may be necessary to turn Allen wrench slightly to align holes.)
10. Remove pin and repeat step number 9 for other slotted screw.

WIRING DIAGRAM FOR GAS SKILLETS

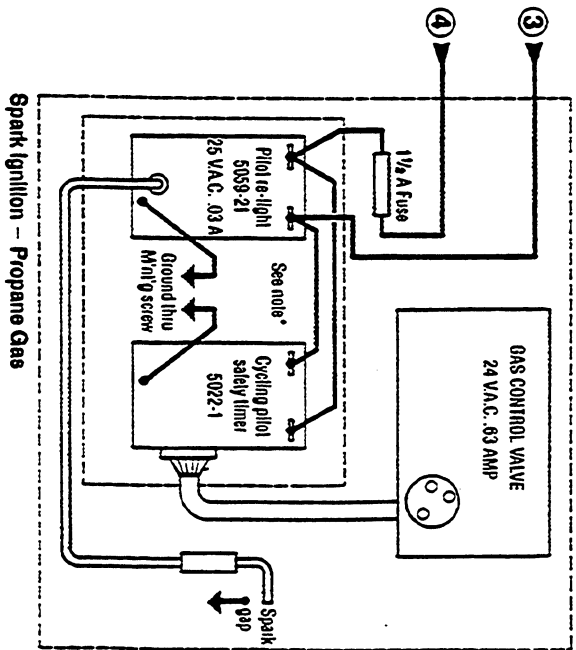
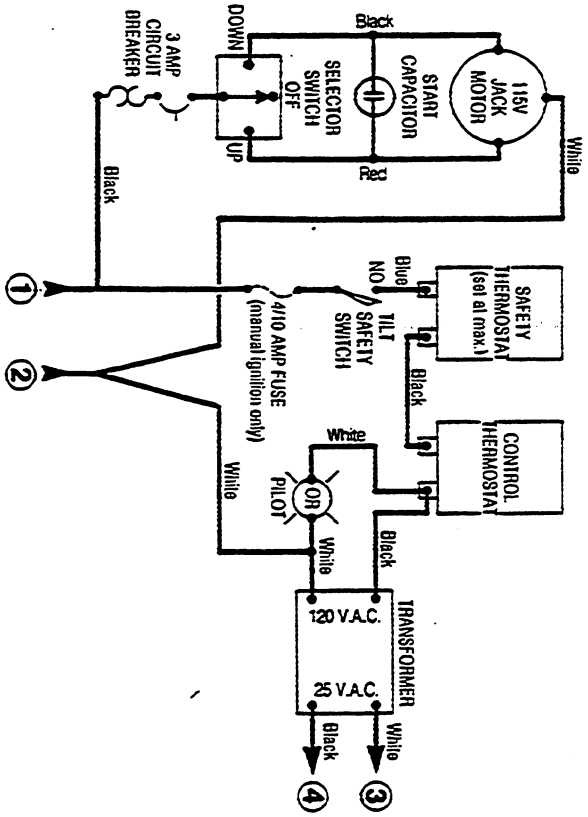

Spark Ignition - Propane Gas

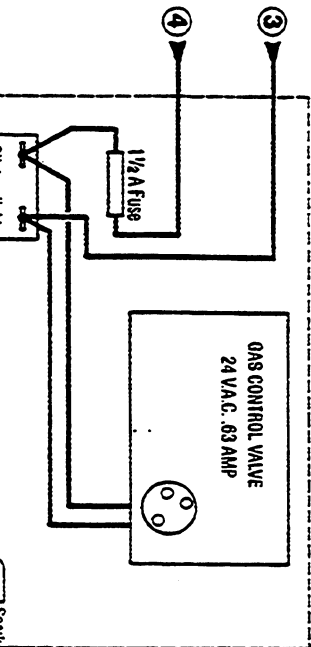
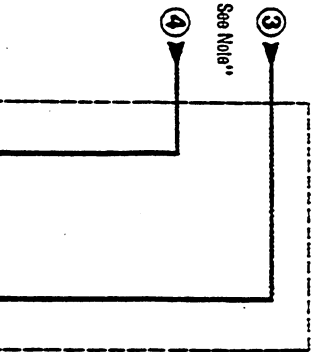
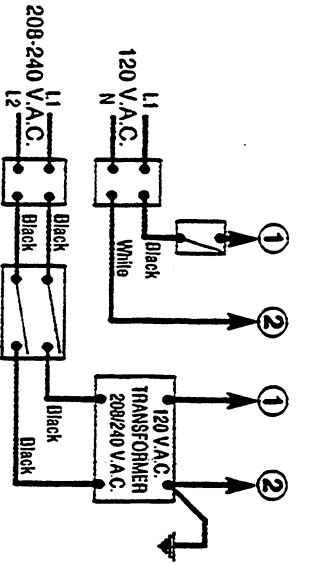

Spark Ignition - Natural Gas

NOTE -- Thermocouple is part of the gas control valve, therefore not shown on this electrical diagram.

NOTE* -- Pilot re-light and cycling pilot safety limiter may be combined as one control. Cal. No. 50A22-1

NOTE** -- 25 V.A.C. transformer not used with 120 V.A.C. gas control valve

