

# Cleveland

## Service Manual

### FLOOR MODEL ELECTRIC SKILLET

MODEL: SEL  
SEM



# MODEL SEL & SEM OPERATING CONTROLS AND INDICATORS

For your better understanding and confidence, the following explanation of the control system used on these skillets is offered.

<b>Item No.</b>	<b>Description</b>	<b>Function</b>
9	On/Off Toggle Switch (Control Housing Dwg.)	Controls electric power to the skillet.
4	Pilot Light (Control Housing Dwg.)	When illuminated, one light indicates power is on to the skillet while the other indicates power to the elements, cycling on and off with the thermostat.
11	Thermostat Control Knob (Control Housing Dwg.)	This control knob allows the operator to select various heat increments for operating the skillet.
10	Fuse (Power Jack Housing Dwg.)	This fuse protects the power jack from excessive current.

# MODELS SEL AND SEM SKILLET BOTTOM

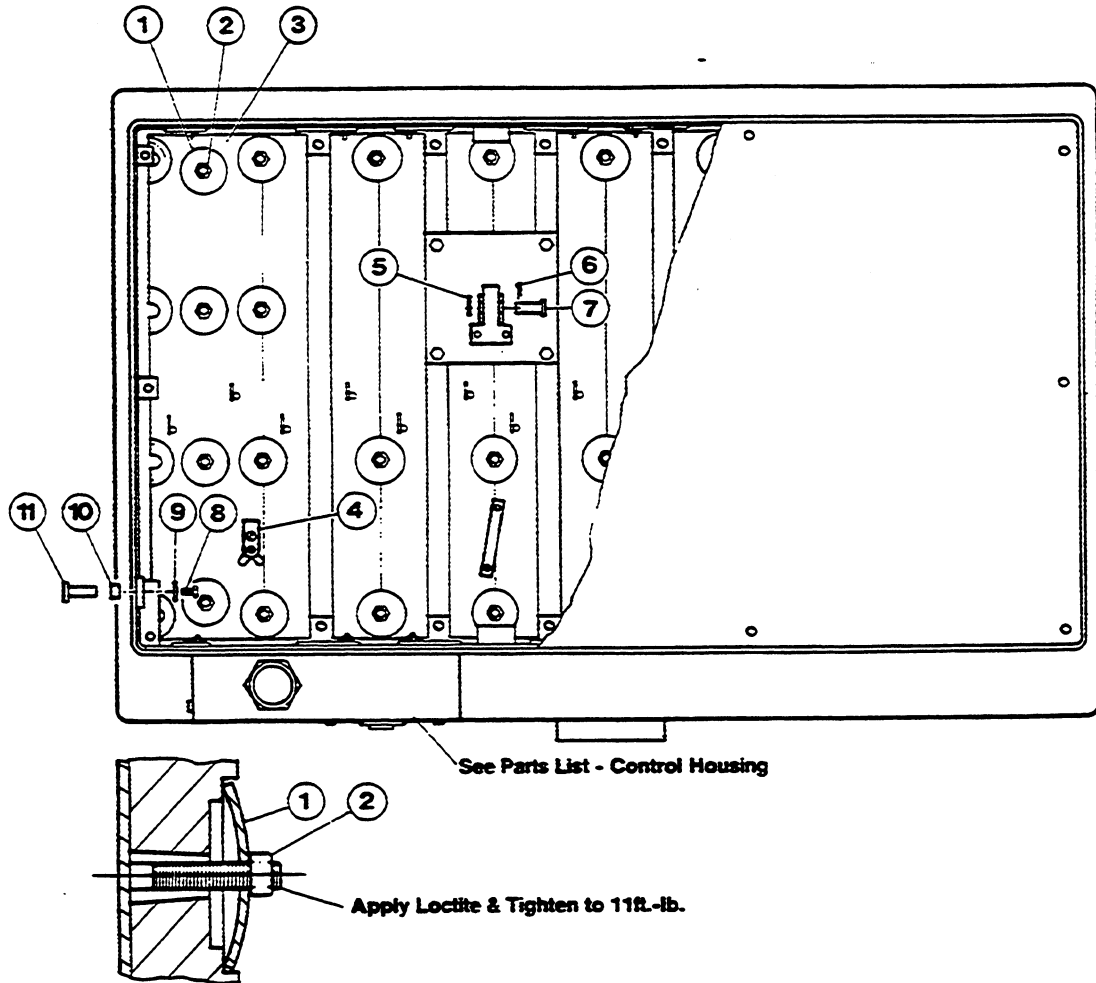

Item No.	Part No.	Description	Qty.
1	SK50019	Washer, Spherical	*28,36
2	FA21024	Nut, 5/16-18	*28,36
3	<del>SK00018</del> 2231498	Element Block Assembly	*6,8
4	<del>SK50028</del> KE55340	Thermostat, High Limit 575°F (302°C)	1
5	SK50155	Washer	1
6	SK50156	Cotter Pin	1
7	SK50153	Pin	1
8	KE00349	Bolt, 5/16-18 x 1/2"	2
9	SK50434	Washer	2
10	SK50183	Bushing	2
11	SK50150	Pin	2

\*The first figure represents the 30 gallon model and the second figure represents the 40 gallon model.

Use only replacement parts which are factory supplied as to preserve the certification of Underwriters Laboratories, American Gas Association, Canadian Standards Association or Canadian Gas Association (as applicable). The use of other than factory supplied replacement parts will void the warranty.

# MODELS SEL AND SEM SKILLET CONTROL HOUSING

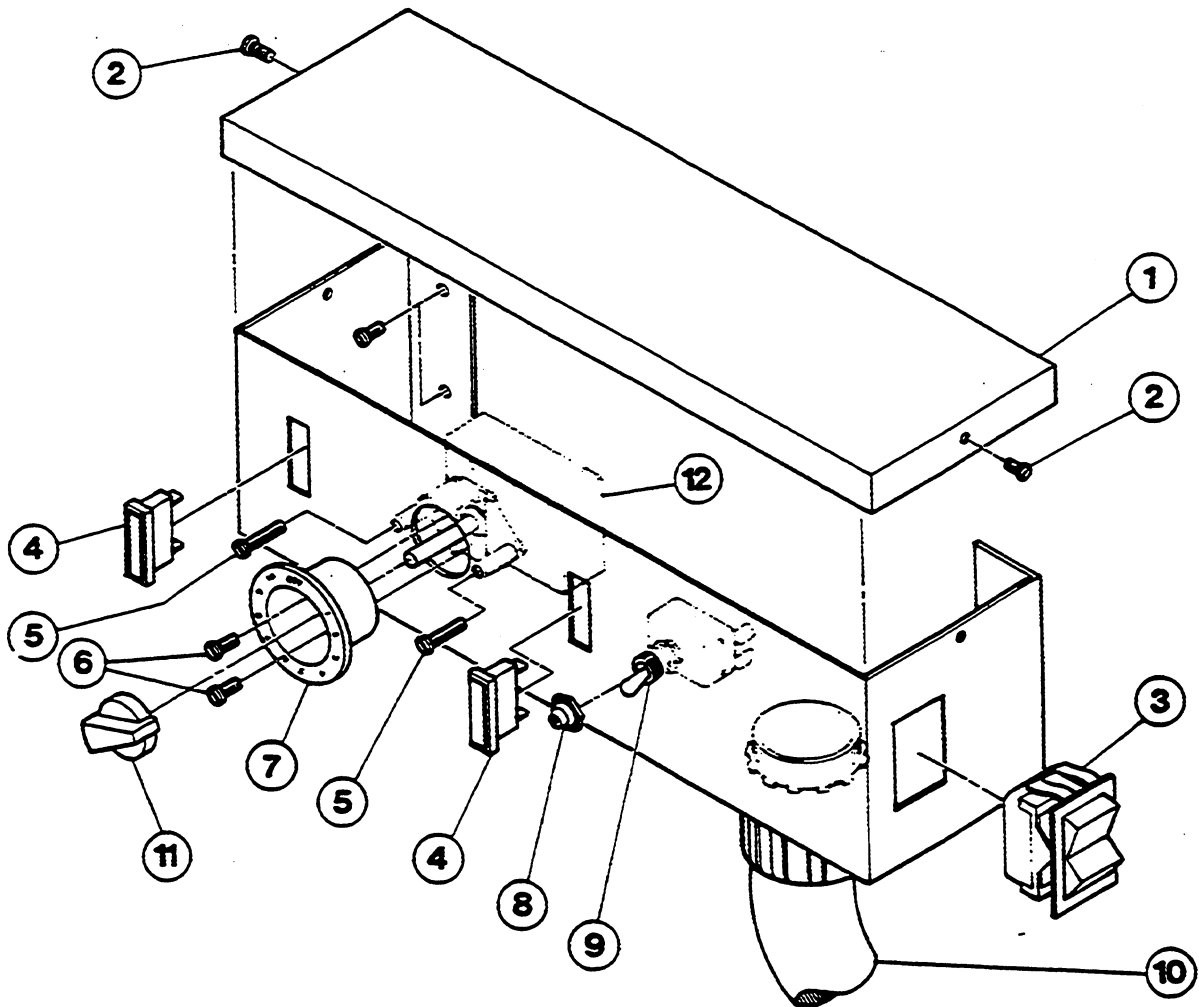

Item No.	Part No.	Description	Qty.
1	SK50107	Console Cover	1
2	FA11502	Screw, Top Cover, 10-24 x 1/2"	2
3	SK50175	Switch, Rocker	1
4	SK50057	Pilot Light	2
5	FA10140	Screw, Thermostat, 6-32 x 1 1/4"	2
6	FA10135	Screw, Bezel, 6-32 x 5/8"	2
7	SK00031	Bezel	1
8	SK50062	Rubber Boot	1
9	SK50056	Switch, Toggle, ON/OFF	1
10	SK50217	Flexible Conduit	1
11	SK50059	Knob, Thermostat	1
12	SK00028	Thermostat	1

Use only replacement parts which are factory supplied as to preserve the certification of Underwriters Laboratories, American Gas Association, Canadian Standards Association or Canadian Gas Association (as applicable). The use of other than factory supplied replacement parts will void the warranty.

# MODELS SEL AND SEM SKILLET POWER JACK HOUSING

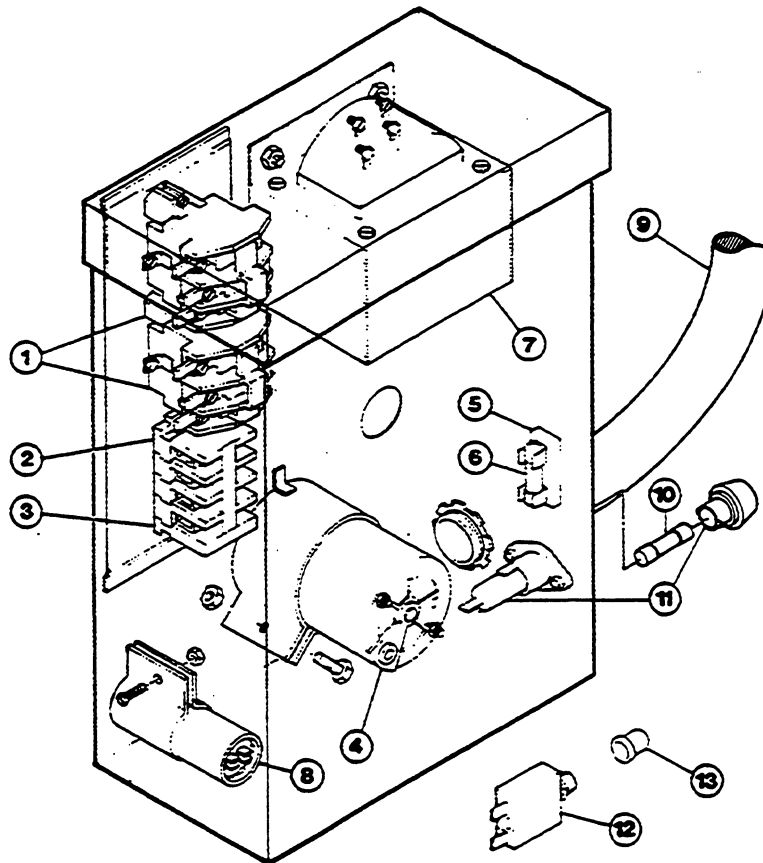

Item No.	Part No.	Description	Qty.
1	KE50749	Contactor, 208-240V (SEL-30, SEM-30: 208-240V)	2
	KE51322	Contactor, 208-240V (SEL-40, SEM-40: 208-240V)	2
	SK50224	Contactor, 120V (All 480V units)	2
2	KE50377	Terminal Block Section	4
3	KE50376	Terminal Block End Section	1
4	SE50004	Motor (See Power Jack Assy. Dwg.)	1
5	KE51139	Fuse Holder (480V units)	1
6	SK50445	Fuse, 3 Amp (480V units)	1
7	SK50221	Transformer 208/120V	1
	SK50264	Transformer 220-240/120V	1
	SK50222	Transformer 480, 240/240, 120V	1
8	SK50207	Capacitor, 43-52 micro Farads	1
9	SK50217	Flexible Conduit	1
10	SK50442	Fuse, 10 Amp (after Mar. 1/85)	1
11	SK50441	Fuse Holder (after Mar. 1/85)	1
12	SK50208	Circuit Breaker, 3 Amp (before Mar. 1/85)	1
13	KE50580	Rubber Boot (before Mar. 1/85)	1

Use only replacement parts which are factory supplied as to preserve the certification of Underwriters Laboratories, American Gas Association, Canadian Standards Association or Canadian Gas Association (as applicable). The use of other than factory supplied replacement parts will void the warranty.

# MODELS SEL AND SEM SKILLET POWER JACK ASSEMBLY

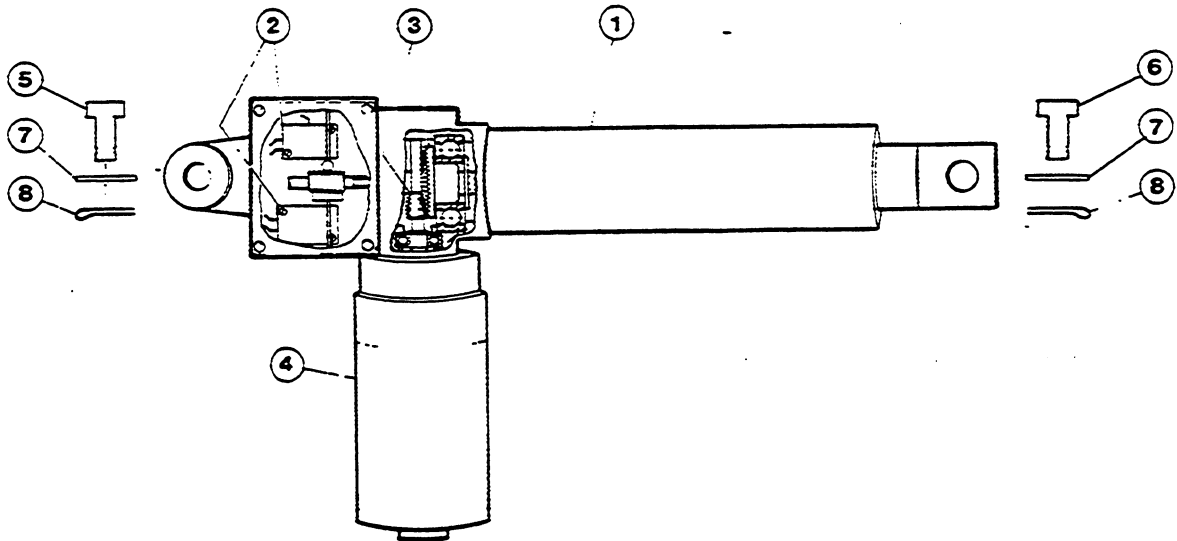

Item No.	Part No.	Description	Qty.
1	SK50145	Complete Jack	1
2	SE50002	Limit Switch	2
3	SE50003	Gear Set	1
4	SE50004	Motor	1
5	SK50154	Mounting Pin, Bottom Jack	1
6	SK50153	Mounting Pin, Top Jack	1
7	SK50155	Washer	2
8	SK50156	Cotter Pin	2

Use only replacement parts which are factory supplied as to preserve the certification of Underwriters Laboratories, American Gas Association, Canadian Standards Association or Canadian Gas Association (as applicable). The use of other than factory supplied replacement parts will void the warranty.

# MODELS SEL AND SEM COVER VENT CAP AND DEFLECTOR

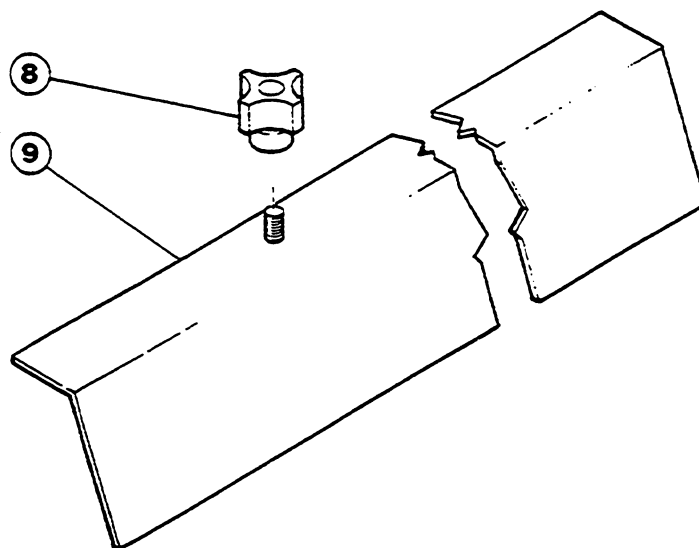
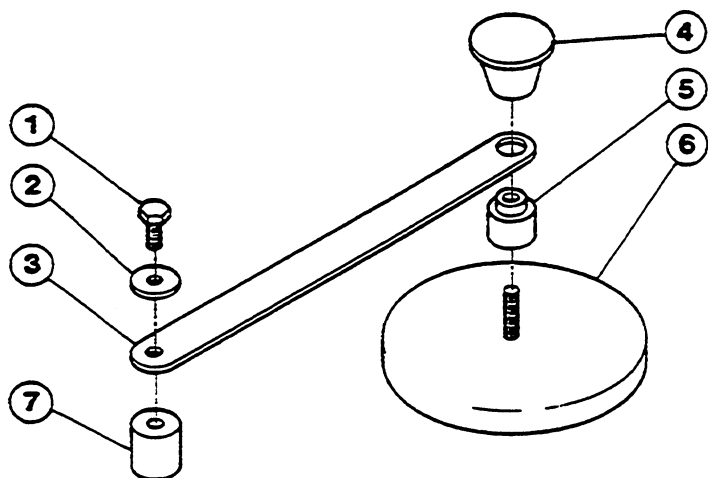

Item No.	Part No.	Description	Qty.
1	SK00105	Screw, 1/4-20 x 3/8"	1
2	SK50179	Washer	1
3-6	SK00054	Vent Cap Assy.	1
3	SK51032	Support Arm	1
4	SK50218	Knob	1
5	SK50131	Spacer	1
6	SK00059	Cover	1
7	SK50133	Spacer	1
8	SK50444	Knob	*3, 4
9	SK00175	Deflector Assy. (30 Gal.)	1
	SK00176	Deflector Assy. (40 Gal.)	1

\*The first figure represents the 30 gallon model and the second figure represents the 40 gallon model.

Use only replacement parts which are factory supplied as to preserve the certification of Underwriters Laboratories, American Gas Association, Canadian Standards Association or Canadian Gas Association (as applicable). The use of other than factory supplied replacement parts will void the warranty.

# SKILLET HINGE ASSEMBLY

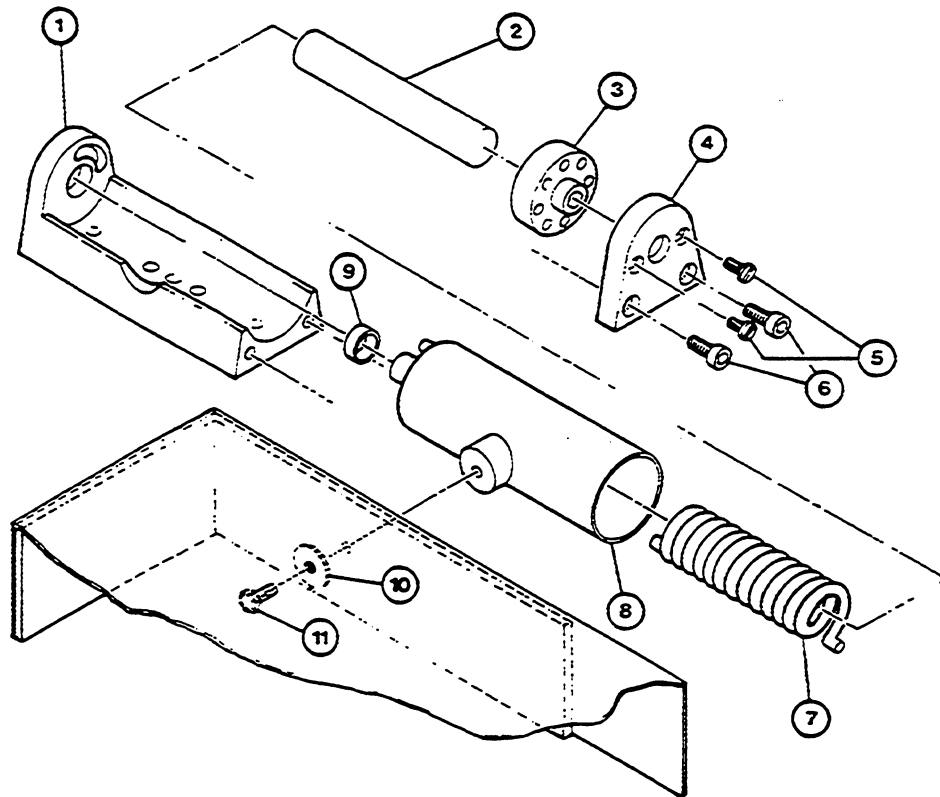

Item No.	Part No.	Description	Qty.
1-9	KE00598	Hinge Assy. (30 Gal.)	2
	SK00168	Hinge Assy. (40 Gal.)	2
1	KE51218	Body, Hinge	1
2	KE50823	Pin, Hinge	1
3	KE50820	Insert, Hinge	1
4	KE50819	End Piece, Hinge	1
5	FA11507	Screw, Tension Adjust, 10-24 x 3/4"	2
6	FA11284	Screw, End Piece, 1/4-20 x 1/2"	2
7	KE50122	Spring, Hinge (30 Gal.)	1
	KE50121	Spring, Hinge (40 Gal.)	1
8	KE51217	Cylinder, Hinge	1
9	KE50824	Bearing, Hinge	1
10	SK50209	Washer	1
11	SK00101	Bolt, 3/8-16 x 1"	1

Use only replacement parts which are factory supplied as to preserve the certification of Underwriters Laboratories, American Gas Association, Canadian Standards Association or Canadian Gas Association (as applicable). The use of other than factory supplied replacement parts will void the warranty.

# FLOOR MODEL ELECTRIC SKILLET SERVICING GUIDE

This section contains servicing information intended for use by Authorized Service Personnel.

**A/ PROBLEM:** Skillet fails to heat with both pilot lights on.

	<b>Probable Cause</b>	<b>Test and Remedy</b>
1.	Faulty contactor/s	Check coils and contacts of contactors. Replace if necessary.
2.	Faulty wiring	Check wiring to contactors. Repair if necessary.

**B/ PROBLEM:** Skillet fails to heat with both pilot lights off. (power switch must be on and thermostat set).

	<b>Probable Cause</b>	<b>Test and Remedy</b>
1.	Main power to skillet is off	Check incoming power at terminal block.
2.	Defective power switch	With power source off, remove wiring from switch and test for continuity. Or with wiring connected and unit on, check for voltage across terminals of switch. Voltage indicates an open circuit. Replace switch if necessary.

**C/ PROBLEM:** Skillet fails to heat with power "ON" pilot illuminated and temperature pilot off. (thermostat must be set).

	<b>Probable Cause</b>	<b>Test and Remedy</b>
1.	Defective thermostat	Shut the unit off and disconnect wiring from thermostat. Check for continuity of thermostat. An open circuit while in the "ON" position, indicates a faulty thermostat. Or with thermostat connected and unit on, check for voltage across thermostat. Voltage indicates an open circuit, indicating a faulty thermostat.
2.	Defective high limit thermostat	Repeat above procedure used for defective thermostat.

**D/ PROBLEM:** Skillet fails to reach maximum 425°F at #10 setting.

**Probable Cause**

**Test and Remedy**

- |    |   |   |
|----|---|---|
| 1. | Defective or improperly adjusted thermostat | As unit shuts off early, check for voltage across thermostat terminals. If there is voltage across terminals, re-calibrate or replace thermostat. |
| 2. | Defective safety thermostat                 | Repeat above procedure used for defective thermostat.   |

**E/ PROBLEM:** Skillet has uneven heat over pan surface.

**Probable Cause**

**Test and Remedy**

- |    |  |  |
|----|--|--|
| 1. | Defective contactor                        | Check contactors for burned out contacts and replace if required.  |
| 2. | Defective heating element block            | Check for continuity between element terminals and from terminals to ground. Either an open circuit between terminals or a short to ground indicates a faulty element. Replace if necessary. |
| 3. | Faulty wiring                              | Inspect condition of wires and connections to elements and contactors. Repair if necessary.  |
| 4. | Uneven torquing of aluminum heating blocks | Follow element block torquing procedure.   |

**F/ PROBLEM:** Skillet fails to tilt with power on and tilt switch activated.

**Probable Cause**

**Test and Remedy**

- |    |                       |   |
|----|-----------------------|---|
| 1. | Blown 10 amp fuse     | Check and replace if necessary.   |
| 2. | Defective tilt switch | Shut off power to unit and remove wiring from switch. Test switch for continuity. Replace if necessary. |
| 3. | Defective transformer | Measure transformer output for approx. 120 volts. Replace if necessary.                                 |

4. Defective jack or capacitor

First, listen to the jack while trying to tilt. If the jack makes a humming noise, there is a mechanical problem. It may be worn gears. (Item #3, Power jack assy. dwg.) Replace if necessary.

If no noise or sound of motion is emitted from jack, there is an electrical problem. Turn power off and open the jack housing (four cover screws) and check the two limit switches for continuity. Switches need not be disconnected to test for continuity. Replace if necessary. If switches are good, remove the three wires going to the jack motor. Test for continuity across each of the three wires. They should read: between white and red approx. 10 ohms, white and black 15 ohms and between red and black 25 ohms. If any of these readings are incorrect, replace the motor or jack. If they are all correct, replace the capacitor.  
NOTE: Normal current draw for jack is approx. 3 or 4 amps.

**G/ PROBLEM:** Skillet fails to lift at normal speed.

**Probable Cause**

**Test and Remedy**

1. Defective jack or capacitor

Follow procedure in section F/4.

**H/ PROBLEM:** Skillet stops tilting at wrong position.

**Probable Cause**

**Test and Remedy**

Micro switches not adjusted properly

Adjust micro switches (item #2, Power jack assy. dwg.).

## HEATING ELEMENT REMOVAL

1. Tilt the skillet fully forward to access bottom cover plate.
2. Make sure power switch and external circuit breaker (at fuse box or breaker panel) are off.
3. Remove screws from bottom cover plate. Remove plate.
4. Remove four (4) 7/16 inch nuts and washers from stainless retaining plate located at rear of skillet pan.
5. Remove screws and tooth lock washer from retaining bars and slide thru open end where retaining plate was previously removed.

**NOTE:** To remove aluminum blocks situated below Power Jack brace assembly, remove screws and lock washers from retaining bars, but push back and then lift out at opposite end of retaining plate. The retaining bars with the Power Jack brace assembly will come out as one piece. Remove the thermostat bulb (Bracket) and or safety thermostat as required.

6. Disconnect electrical lead wires from elements.
7. Remove ½ inch nuts and spherical washers from heating element blocks. Care should be taken when removing nuts and washers to prevent breaking the studs.
8. Remove heating element blocks. Replace as needed.

**NOTE:** With new element block in place re-tighten nuts on washers with a torque wrench to 11 ft.-lbs. torque.

9. Replace retaining bars, retaining back plate and bottom cover.
  10. Switch external power back on and return skillet to operating position.
- WARNING:** Heating element blocks are very heavy. Use care when handling.

## HEATING ELEMENT BLOCK TORQUING

Uneven torquing of heating element block retaining plate nuts may cause uneven heating of the cooking surface. To retorque, proceed as follows:

1. Tilt the skillet forward.
2. Ensure that the power switch and the external circuit breaker (at fuse box or breaker panel) are off.
3. Remove the bottom cover plate.
4. Loosen the ½ inch nuts on the spherical washers.
5. Using a torque wrench, retighten the nuts to 11 ft.-lbs. torque.
6. Replace the bottom cover plate.

# HINGE ADJUSTMENT INSTRUCTIONS

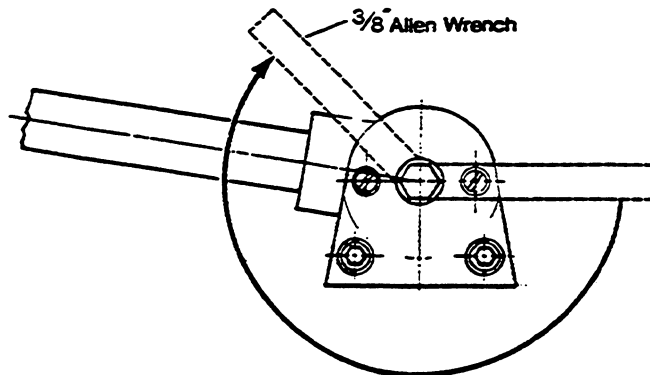

1. Insert  $\frac{3}{8}$ " Allen wrench.
2. Turn clockwise to relieve tension on spring.
3. While tension is released remove one of the two slotted screws.
4. To prevent Allen wrench from springing back abruptly while the second slotted screw is removed, insert a pin (approximately  $\frac{1}{8}$ "") in the hole where the first slotted screw was removed from.
5. Remove second slotted screw.
6. While holding Allen wrench remove pin.
7. Turn Allen wrench clockwise to tighten or counter-clockwise to loosen tension to produce desired effect.
8. Re-insert pin in one of the two holes.
9. Tighten one slotted screw in the other hole (it may be necessary to turn Allen wrench slightly to align holes.)
10. Remove pin and repeat step number 9 for other slotted screw.

# WIRING DIAGRAM-FREE STANDING ELECTRIC, 208-240V SKILLETTS

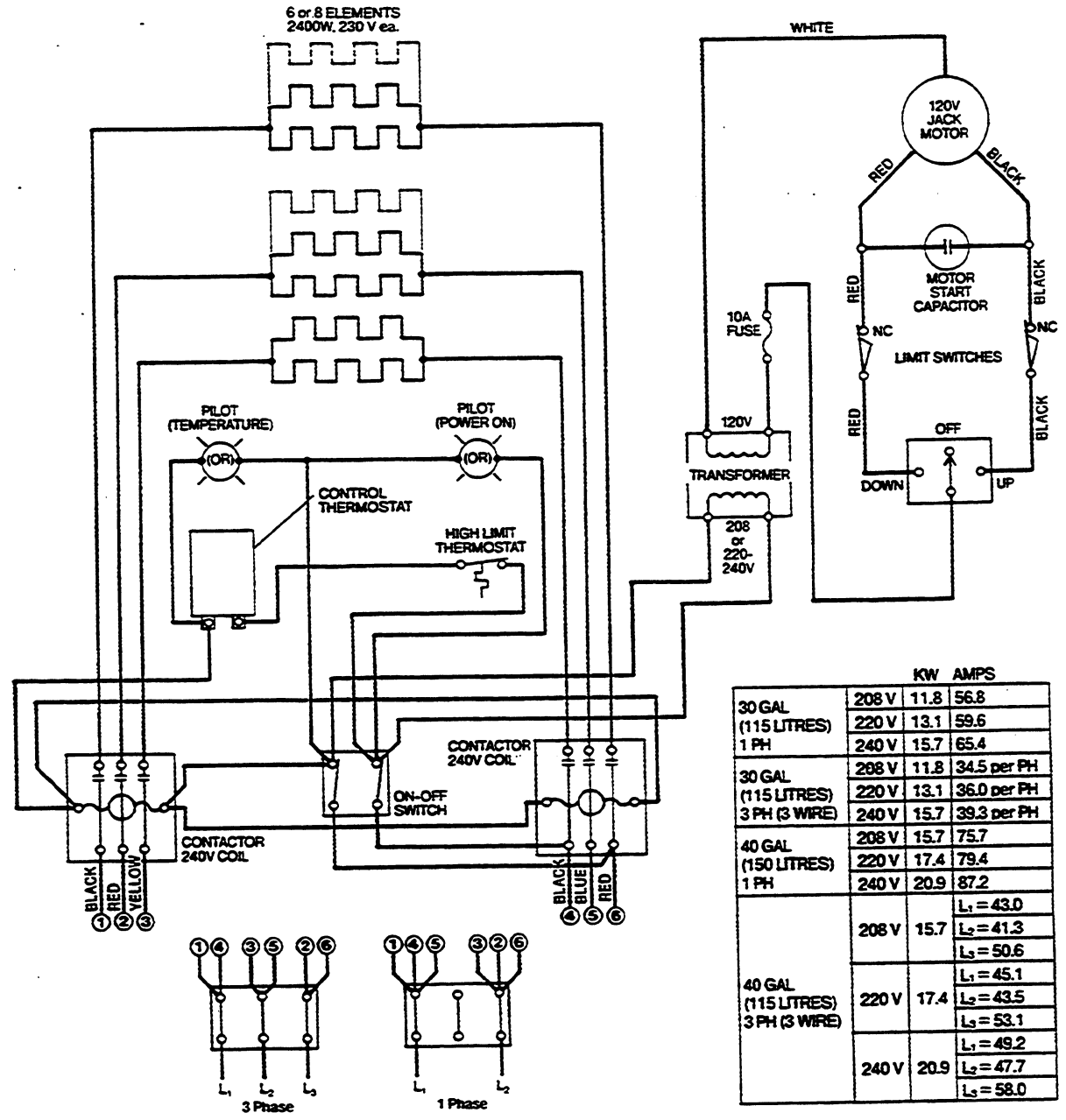

		KW AMPS	
30 GAL (115 LITRES) 1 PH	208 V	11.8	56.8
	220 V	13.1	59.6
	240 V	15.7	65.4
30 GAL (115 LITRES) 3 PH (3 WIRE)	208 V	11.8	34.5 per PH
	220 V	13.1	36.0 per PH
	240 V	15.7	39.3 per PH
40 GAL (150 LITRES) 1 PH	208 V	15.7	75.7
	220 V	17.4	79.4
	240 V	20.9	87.2
40 GAL (115 LITRES) 3 PH (3 WIRE)	208 V	15.7	L <sub>1</sub> = 43.0
			L <sub>2</sub> = 41.3
			L <sub>3</sub> = 50.6
	220 V	17.4	L <sub>1</sub> = 45.1
			L <sub>2</sub> = 43.5
			L <sub>3</sub> = 53.1
	240 V	20.9	L <sub>1</sub> = 49.2
			L <sub>2</sub> = 47.7
			L <sub>3</sub> = 58.0

# WIRING DIAGRAM-FREE STANDING ELECTRIC, 480V SKILLETS

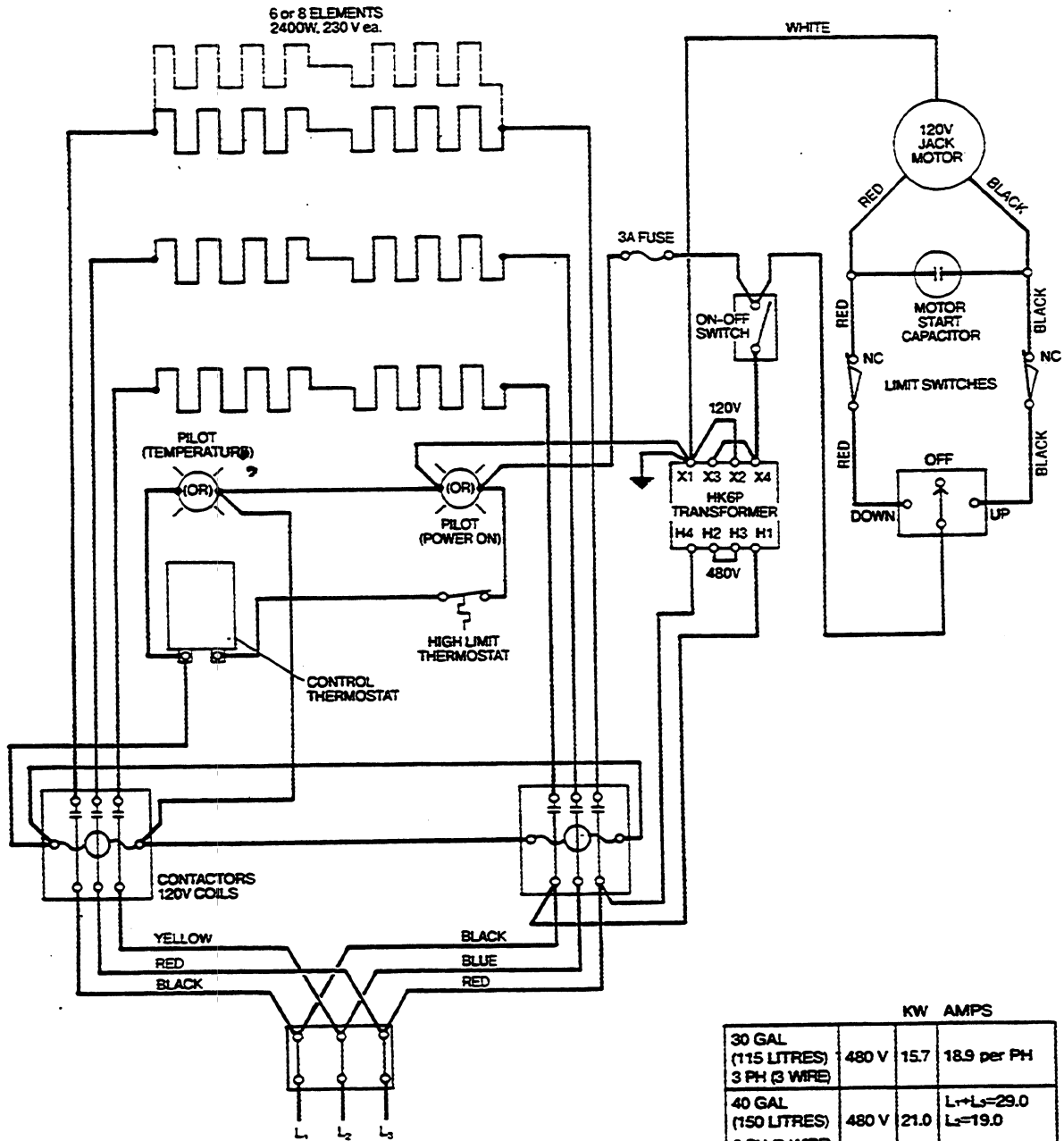

	KW	AMPS
30 GAL (115 LITRES) 3 PH (3 WIRE)	480 V 15.7	18.9 per PH
40 GAL (150 LITRES) 3 PH (3 WIRE)	480 V 21.0	L <sub>1</sub> +L <sub>2</sub> =29.0 L <sub>3</sub> =19.0

