



Visit [www.clevelandrange.com](http://www.clevelandrange.com) to locate a service or sales representative in your area.



# Electric Vertical Mixer Kettles

## Installation, Operation, Maintenance, Parts & Service

This manual is updated as new information and models are released. Visit our website for the latest manual.

### MODELS:

- MKEL-40-T
- MKEL-60-T
- MKEL-80-T
- MKEL-100-T
- TMKEL-40-T
- TMKEL-60-T
- TMKEL-80-T
- TMKEL-100-T



*For your future reference.*

Model # \_\_\_\_\_

Serial # \_\_\_\_\_

← Model # & Serial #.



**Read the manual thoroughly.**  
**Improper installation, operation or maintenance can cause property damage, injury or death.**

### TABLE OF CONTENTS

Statement of Responsibilities .....	1
For your safety .....	2
Installation .....	4
Operating Instructions .....	7
Cleaning Instructions .....	10
Preventative Maintenance .....	11
Trouble Shooting & Maintenance .....	12
Service Parts .....	25



# **STATEMENT OF RESPONSIBILITIES / DÉCLARATION DES RESPONSABILITÉS / DECLARACIÓN DE RESPONSABILIDADES**

This document is for use by experienced and trained Qualified Cleveland Range, LLC Authorized Service Representatives who are familiar with both the safety procedures, and equipment they service. Cleveland Range, LLC assumes no liability for any death, injury, equipment damage, or property damage resulting from use of, improper use of, or failure to use the information contained in this document. Cleveland Range, LLC has made every effort to provide accurate information in this document, but cannot guarantee that this document does not contain unintentional errors and omissions.

The information in this document may be subject to technical and technological changes, revisions, or updates. Cleveland Range, LLC assumes no liability or responsibility regarding errata, changes, revisions, or updates.

Qualified Cleveland Range, LLC Authorized Service Representatives are obligated to follow industry standard safety procedures, including, but not limited to, OSHA regulations, and disconnect / lock out / tag out procedures for all utilities including steam, and disconnect / lock out / tag out procedures for gas, electric, and steam powered equipment and / or appliances.

All utilities (gas, electric, water and steam) should be turned OFF to the equipment and locked out of operation according to OSHA approved practices during any servicing of Cleveland Range equipment

Qualified Cleveland Range, LLC Authorized Service Representatives are obligated to maintain up-to-date knowledge, skills, materials and equipment.

Ce document est destiné à l'usage des Représentants de Service qualifiés et autorisés de Cleveland Range, LLC qui possèdent l'expérience et la formation ainsi que la bonne connaissance des mesures de sécurité et du matériel qu'ils entretiennent.

Cleveland Range, LLC décline toute responsabilité pour tout cas de décès, blessure, dommage matériel ou dommage aux biens résultant de l'utilisation, de la mauvaise utilisation ou du manquement d'utilisation des renseignements contenus dans ce document.

Cleveland Range, LLC s'est efforcé à fournir des renseignements précis dans ce document mais ne peut garantir que ce document soit exempt d'erreurs et d'omissions non intentionnelles.

Les renseignements contenus dans ce document peuvent être assujettis à des changements techniques et technologiques, des révisions ou des mises à jour.

Cleveland Range, LLC décline toute obligation ou responsabilité concernant les errata, modifications, révisions ou mises à jour.

Les Représentants de Service qualifiés et autorisés de Cleveland Range, LLC sont tenus de se conformer aux mesures de sécurité normalisées de l'industrie, y compris, mais sans s'y limiter, les réglementations de l'OSHA, les procédures de débranchement / verrouillage / étiquetage relatives à tous les services publics, dont l'approvisionnement en vapeur, et les procédures de débranchement / verrouillage / étiquetage relatives aux équipements et/ou appareils fonctionnant au gaz, à l'électricité et à la vapeur.

Au cours de tout entretien d'un appareil Cleveland Range, tous les services publics (gaz, électricité, eau et vapeur) doivent être FERMÉS au niveau de l'appareil et le dispositif de fonctionnement doit être verrouillé suivant les pratiques approuvées de l'OSHA.

Les Représentants de Service qualifiés et autorisés de Cleveland Range, LLC sont tenus d'actualiser en permanence leurs connaissances, compétences, matériel et équipement.

Este documento está destinado para el uso de los Representantes de Servicio calificados y autorizados de Cleveland Range, LLC quienes cuentan con la experiencia y la capacitación así como el buen conocimiento de las medidas de seguridad y de los equipos que mantienen.

Cleveland Range, LLC, declina toda responsabilidad en caso de cualquier fallecimiento, lesiones, daños al equipo o daños a la propiedad resultantes de la utilización, del uso indebido o de la falta de utilización de la información provista en este documento.

Cleveland Range, LLC se ha esforzado en suministrar información precisa en este documento, pero no puede garantizar que este documento esté exento de errores y de omisiones no intencionales.

La información contenida en este documento podría estar sujeta a cambios técnicos o tecnológicos, revisiones o actualizaciones. Cleveland Range, LLC declina toda obligación o responsabilidad con respecto a erratas, modificaciones, revisiones o actualizaciones.

Los Representantes de Servicio calificados y autorizados de Cleveland Range, LLC tienen la obligación de seguir los procedimientos estándar de seguridad de la industria; los cuales incluyen pero no se limitan a los reglamentos de la OSHA (La Administración de la Seguridad y Salud Ocupacionales), los procedimientos de desconexión, cierre y etiquetado relativos a todos los servicios públicos incluyendo el suministro de vapor y los procedimientos de desconexión, cierre y etiquetado para los equipos y/o aparatos que funcionan a base de gas, electricidad o vapor.

Cuando se esté dando servicio o mantenimiento a un aparato de Cleveland Range, todos los servicios públicos (gas, electricidad, agua y vapor) deben estar APAGADOS para el equipo en cuestión y se debe seguir el procedimiento de cierre de operaciones de acuerdo con las prácticas aprobadas por la OSHA.

Los Representantes de Servicio calificados y autorizados de Cleveland Range, LLC tienen la obligación de actualizar constantemente sus conocimientos, destrezas, materiales y equipamiento.

## **FOR YOUR SAFETY / POUR VOTRE SÉCURITÉ / PARA SU SEGURIDAD**

### **FOR YOUR SAFETY**

**Do not store or use gasoline or any other flammable liquids and vapours in the vicinity of this or any other appliance.**

### **POUR VOTRE SÉCURITÉ**

**Ne pas entreposer ou utiliser d'essence ou d'autres liquides ou vapeurs inflammables à proximité de cet appareil ou de tout autre appareil.**

### **PARA SU SEGURIDAD**

**No guarde ni use gasolina o cualesquiera otros líquidos o vapores inflamables en las cercanías de éste o cualquier otro aparato.**

**WARNING: Improper installation, operation, adjustment, alteration, service or maintenance can cause property damage, injury or death. Read the installation and operating instructions thoroughly before installing, operating or servicing this equipment.**

**AVERTISSEMENT : Toute mauvaise pratique en matière d'installation, de fonctionnement, de réglage, de modification, d'entretien ou de maintenance peut causer des dommages matériels, des blessures ou la mort. Lisez la totalité des instructions d'installation et d'utilisation avant d'installer, d'utiliser ou d'entretenir cet équipement.**

**ADVERTENCIA: La indebida instalación, operación, ajuste, modificación, servicio o mantenimiento puede ocasionar daños a la propiedad, lesiones o muerte. Lea detenidamente las instrucciones de instalación y de operación antes de instalar, poner a funcionar o dar servicio a este equipo.**

Do not spray aerosols in the vicinity of this appliance while it is in operation.

This appliance is not to be used by persons with reduced physical, sensory or mental capabilities, or lack of experience and knowledge, unless they have been given supervision or instruction concerning use of the appliance by a person responsible for their safety.

This appliance is not for use by children and they must be supervised not to play with it.

Retain this manual for your reference.

Ne pas pulvériser des aérosols dans le voisinage de cet appareil alors qu'il est en fonctionnement.

Cet appareil ne doit pas être utilisé par des personnes dont les capacités physiques, sensorielles ou mentales sont réduites, ou des personnes dénuées d'expérience ou de connaissance, sauf si elles ont pu bénéficier, par l'intermédiaire d'une personne responsable de leur sécurité, d'une surveillance ou d'instructions préalables concernant l'utilisation de l'appareil.

Conservez ce manuel pour votre référence.

No pulverice aerosoles en las proximidades de este aparato mientras está en funcionamiento.

Este aparato no debe ser utilizado por personas con capacidades físicas, sensoriales o mentales reducidas, o que no tengan la experiencia y los conocimientos adecuados, a menos que estas personas hayan recibido supervisión e instrucciones en cuanto al uso del aparato por la persona responsable de la seguridad de ellas.

Guarde este manual para su referencia.



## WARNING / AVERTISSEMENT / ADVERTENCIA



Improper installation, operation, adjustment, alteration, service or maintenance can cause property damage, injury or death. Read the installation and operating instructions thoroughly before installing, operating or servicing this equipment. / Toute mauvaise pratique en matière d'installation, de fonctionnement, de réglage, de

modification, d'entretien ou de maintenance peut causer des dommages matériels, des blessures ou la mort. Lisez la totalité des instructions d'installation et d'utilisation avant d'installer, d'utiliser ou d'entretenir cet équipement. / La indebida instalación, operación, ajuste, modificación, servicio o mantenimiento puede ocasionar daños a la propiedad, lesiones o muerte. Lea detenidamente las instrucciones de instalación y de operación antes de instalar, poner a funcionar o dar servicio a este equipo.



Do not lean on or place objects on lip. / Ne vous penchez pas sur ou ne placez pas des objets sur la lèvres. / No se apoye ni coloque objetos en el labio.



Hot product and surfaces. / Produit et surfaces chaudes. / Producto y superficies calientes.

Do not touch. / Ne pas toucher. / No la toque



Stand clear of product discharge path when discharging hot product. / Écartez-vous du chemin de décharge d'un produit chaud. / Permanezca alejado de la ruta de descarga del producto al vaciar producto caliente.



Keep hands away from moving parts and pinch points. / Gardez les mains loin des pièces mobiles et des points de pincement. / Mantenga las manos lejos de piezas móviles y puntos de presión muy localizada.



Do not fill kettle above recommended level marked on outside of kettle. / Ne remplissez pas la chaudière en excès du niveau recommandé marqué sur la chaudière. / No llene la marmita arriba del nivel recomendado marcado fuera de la marmita.



Unit must be anchored as per manual. / Unité doit être ancrée selon les directives du manuel. / Unidad debe estar fijado según el manual.



Keep appliance and area free and clear of combustibles. / Gardez l'appareil et son entourage libre de tous combustibles. / Mantenga el aparato y el área libres de combustibles.



Do not attempt to operate this appliance during a power failure. / N'essayez pas de faire fonctionner cet appareil lors d'une panne de courant. / No intente poner en marcha este aparato durante un fallo de suministro eléctrico.



Inspect unit daily for proper operation. / Inspectez l'unité tous les jours pour son bon fonctionnement. / Inspeccione diariamente el funcionamiento correcto de la unidad.



Heavy / Lourd / Pesado

Team or mechanical lift. / Équipe ou remontée mécanique. / Equipo o elevador mecánico.



Surfaces and product may be hot! Wear protective equipment. / Les surfaces et le produit peuvent être chauds! Portez un équipement de protection. / ¡Las superficies y el producto pueden estar calientes! Utilice equipo protector.



Floor may become slippery from product spillage. / Déversement de produit peut causer de plancher à être glissant. / Derrame de producto puede causar piso a ser resbaladizo.



Pressurized device. / Appareil sous pression. / Dispositivo de presión.

Keep clear of pressure relief discharge. / Restez à l'écart de la soupape de sûreté. / Permanezca alejado de la descarga de presión.



Do not climb, sit or stand on equipment. / Il ne faut pas monter, s'asseoir ni se tenir debout sur l'équipement. / No subirse, ni sentarse ni pararse sobre el equipo.



Do not remove guards or operate without them. / Ne pas supprimer les gardes ou fonctionner sans eux. / No retire los guardias ni funcionar sin ellos.

## SERVICING / ENTRETIEN / SERVICIO



Remove electrical power prior to servicing. / Coupez l'alimentation électrique avant l'entretien. / Desconecte la energía eléctrica antes de darle servicio.



Risk of electric shock. / Risque de choc électrique. / Riesgo de choque eléctrico.



Ensure kettle is at room temperature and pressure gauge is showing zero or less prior to removing any fittings. / Assurez-vous que la chaudière est à température ambiante et que le manomètre est à zéro ou moins avant de retirer des accessoires. / Asegúrese de que la marmita esté a temperatura ambiente y el manómetro esté mostrando cero o menos antes de retirar cualquier accesorio.

Have a qualified service technician maintain your equipment. / Demandez à un technicien en entretien et en réparation qualifié d'effectuer l'entretien de votre équipement. / Haga que un técnico de servicio calificado mantenga su equipo

# INSTALLATION

## GENERAL

Environment:

Operating Criteria	Acceptable Range
Ambient Air Temperature	15-40 degrees Celsius
Relative Humidity	0-80%
Altitude	0-3000 meters
Voltage	208-480, 3ph
Location	Inside building, under ventilation hood

Insure gas and electrical supplies match rating plate.

Installation of the kettle must be accomplished by qualified installation personnel working to all applicable local and national codes.

This equipment is built to comply with applicable standards for manufacturers. Included among those approval agencies are: UL, NSF, ASME/N.Bd., CSA, ETL, and others. Many local codes exist, and it is the responsibility of the owner/installer to comply with these codes.

Observe all clearance requirements. Do not obstruct the flow of combustion and ventilation air.

## RECEIVING INSPECTION

Before unpacking visually inspect the unit for evidence of damage during shipping.

If damage is noticed, do not unpack the unit, follow shipping damage instructions.

## SHIPPING DAMAGE INSTRUCTIONS

If shipping damage to the unit is discovered or suspected, observe the following guidelines in preparing a shipping damage claim.

1. Write down a description of the damage or the reason for suspecting damage as soon as it is discovered. This will help in filling out the claim forms later.
2. As soon as damage is discovered or suspected, notify the carrier that delivered the shipment.
3. Arrange for the carrier's representative to examine the damage.
4. Fill out all carrier claims forms and have the examining carrier sign and date each form.

## APPROXIMATE WEIGHTS

Model #	Unit	Unit with shipping box
MKEL40T	820 lbs.	890 lbs.
MKEL60T	870 lbs.	940 lbs.
MKEL80T	1,130 lbs.	1,200 lbs.
MKEL100T	1,285 lbs.	1,355 lbs.

Model #	Unit	Unit with shipping box
TMKEL40T	1,600 lbs.	1,670 lbs.
TMKEL60T	1,670 lbs.	1,740 lbs.
TMKEL80T	1,840 lbs.	1,910 lbs.
TMKEL100T	2,150 lbs.	2,220 lbs.

## UNCRATING

### Caution:

Straps under tension and will snap when cut.

Carton may contain staples and skid contains nails.

Use proper safety equipment and precautions.

Unit is heavy use adequate help or lifting equipment as needed.

1. Carefully cut any straps from container.
2. Lift off carton.
3. Inspect for hidden damage. If found refer to "SHIPPING DAMAGE INSTRUCTIONS".
4. Cut strap holding unit.
5. Remove lag bolts from feet.
6. Remove manual from kettle pot. Write down the model# and serial# of the unit onto the front of this manual.
7. Lift kettle off skid and move kettle to its installation location.
8. Discard packaging material according to local and or state requirements.



Model/  
Serial#



## VENTILATION

Operation of these units can produce significant levels of steam and condensate, it is recommended they be installed under a ventilation hood in a room which has provisions for adequate make up air. Further information can be obtained by referring to the U.S.A. National Fire Protection Associations NFPA96 regulations. These standards have also been adopted by the National Building Code in Canada.

## Positioning

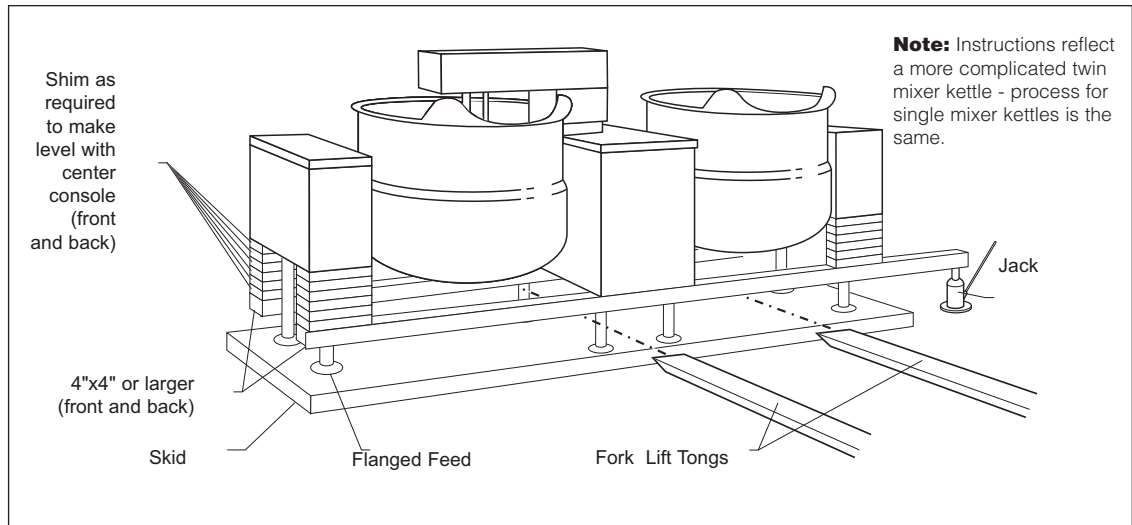

## MOVING UNIT

1. While still on skid, move unit as close to final installation position as possible.
2. Prepare unit for lifting as shown in diagram.
3. Lift gently with a forklift or jacks and remove skid.
4. Lower gently to ground and remove forklift and blocking.
5. If unit has to be re-positioned, slide gently. Do not twist or push one side of unit excessively and cause binding on trunnions.

## LEVELING

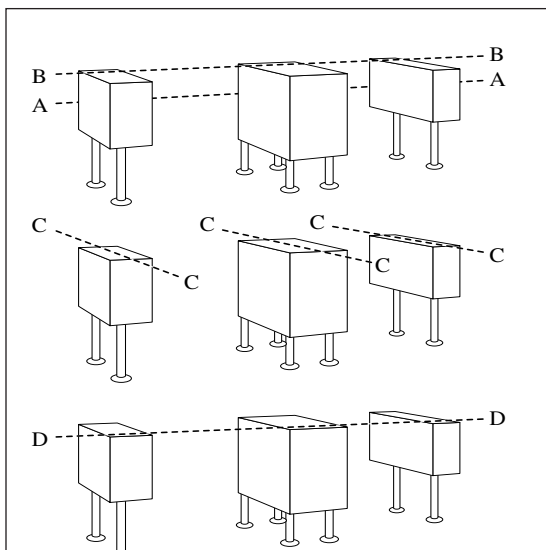

1. With straight-edge, line the backs of the consoles up with each other (dotted line **A**).
2. Level and straight-edge backs of consoles (dotted line **B**). Adjustments are made by turning flanges on back feet only.
3. Level consoles individually from front to back (dotted lines **C**). Adjustments are made by turning flanges on front feet only.
4. Re-check that the back is level (dotted line **B**) and then the front (dotted line **D**). Adjust if necessary.

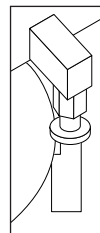

5. Check that mixer bridge is level and guide pins (see illustration) lock smoothly without binding. If not repeat steps **1** through **4**.

**NOTE:** See Operating Instructions before operating unit.

6. Make electrical connections (see electrical service connections) and test mixer bridge as follows:
  - ⇒ **A/** Raise mixer bridge.
  - ⇒ **B/** Swing bridge out over centre console.
  - ⇒ **C/** Swing bridge to the left as far as possible.
  - ⇒ **D/** Lower bridge.
  - ⇒ **E/** Bridge pins should enter pin hole on kettle perfectly, If not return to step 1 and repeat leveling steps.
  - ⇒ **F/** Raise bridge and swing to far right (for twin mixers only).
  - ⇒ **G/** Repeat steps **D** and **E** (for twin mixers only).
7. Once positioned and leveled, permanently secure the kettle's flanged feet to the floor using 5/16 inch stainless steel lag bolts and floor anchors (supplied by the installer). Secure each of the flanged feet with one bolt in each hole. Seal joints of flanged feet with a silicone sealant.

## ELECTRICAL

### **ENSURE THE ELECTRICAL SUPPLY MATCHES THE KETTLE'S REQUIREMENTS AS STATED ON THE RATING LABEL.**

Install in accordance with local codes and/or the National Electric Code ANSI/NFPA No 70-1981 (USA) or the Canadian Electric Code CSA Standard C22.1 (Canada). A separate fused disconnect switch must be supplied and installed. The kettle must be electrically grounded by the installer.

The electric supply must match the power requirements specified on the kettle's rating plate. The copper wiring must be adequate to carry the required current at the rated voltage. Refer to the specification sheet for electrical specifications.

1. Ensure main power is turned off before connecting wires.
2. Remove the screws at the rear of the center console cover, and remove the cover. A wiring diagram is affixed to the underside of the console cover.
3. Feed permanent copper wiring 18" through the cut-out in the bottom of the console. Connect wiring in junction box in the bottom of the console.
4. Turn main power back on.
5. Check for correct rotation of electric motor (access by removing top front cover on center console). If rotation is incorrect, disconnect main power and reverse any two of the three live lines.
6. Replace the console cover and secure it with screws.

## CLEANING

After installation the kettle must be thoroughly cleaned and sanitized prior to cooking.

## INSTALLATION CHECKS

Although the kettle has been thoroughly tested before leaving the factory, the installer is responsible for ensuring the proper operation of kettle once installed.

1. Before turning the kettle on, read the vacuum/pressure gauge. The gauge's needle should be in the green zone. If the needle is in the "VENT AIR" zone, follow air venting procedure.
2. Supply power to the kettle by placing the fused disconnect switch to the "ON" position.
3. Turn the temperature control knob to "1" (Min.). The green LED light should remain lit, indicating the burner is lit, until the set temperature is reached. Then the green light will cycle on and off, indicating the burner is cycling on and off to maintain temperature.
4. Tilt the kettle forward. After a few seconds the red "LOW WATER" light should be lit when the kettle is in a tilted position. This light indicates that the burner has automatically been shut off by the kettle's safety circuit. This is a normal condition when the kettle is in a tilted position.
5. Raise the kettle to the upright position. The red "LOW WATER" light should go out when the kettle is upright.
6. Turn the temperature control knob to "10" (Max.) and allow the kettle to preheat. The green light should remain on until the set temperature is reached. Then the green light will cycle ON and OFF, indicating the burner is cycling ON and OFF to maintain temperature.

## MIXER

1. Raise Bridge - If bridge does not raise then check motor rotation. Bridge should not raise until speed control is turned to minimum and then adjusted back up.
2. Swing Bridge - Bridge when fully raised should swing without hitting any object, i.e. control housing, kettle lip. Check that hydraulic hoses are not being pinched by stops on swivel assembly.
3. Tilt Kettle - Kettle tilts smoothly both down and back up. If power tilt, check that micro switches are adjusted properly (kettle is level in upright position and drains fully when tilted) and are not being crushed by gear.
4. Lower Bridge - Raise bridge. Switch to mix. Turn speed control to zero to reset micro switch then set speed control to number four. Check that unit does not begin to mix until bridge has lowered part way into the kettle. Check that mixer bridge pin lowers into pin hole correctly
5. Speed Control - Main - Main agitator arm not rotating when set at "0" but will start to move slowly on "1". Speed control makes positive contact with micro switch.
6. Speed Control - Secondary - Set main speed control to five. Adjust secondary control from minimum to maximum. Look for considerable speed variance.
7. Water Faucets - Turn on hot water faucet. Turn off and check for leaks in piping and drips from faucet spout. Repeat above with cold water faucet.
8. Product Discharge - Add water to kettle. Check for leaks from valve. Open and close valve a few times Valve and check for leaks again.

**WARNING**

If for any reason this unit is not functioning correctly DO NOT OPERATE. Contact your authorized service agent.

# OPERATING INSTRUCTIONS



## OPERATING CONTROLS AND INDICATORS

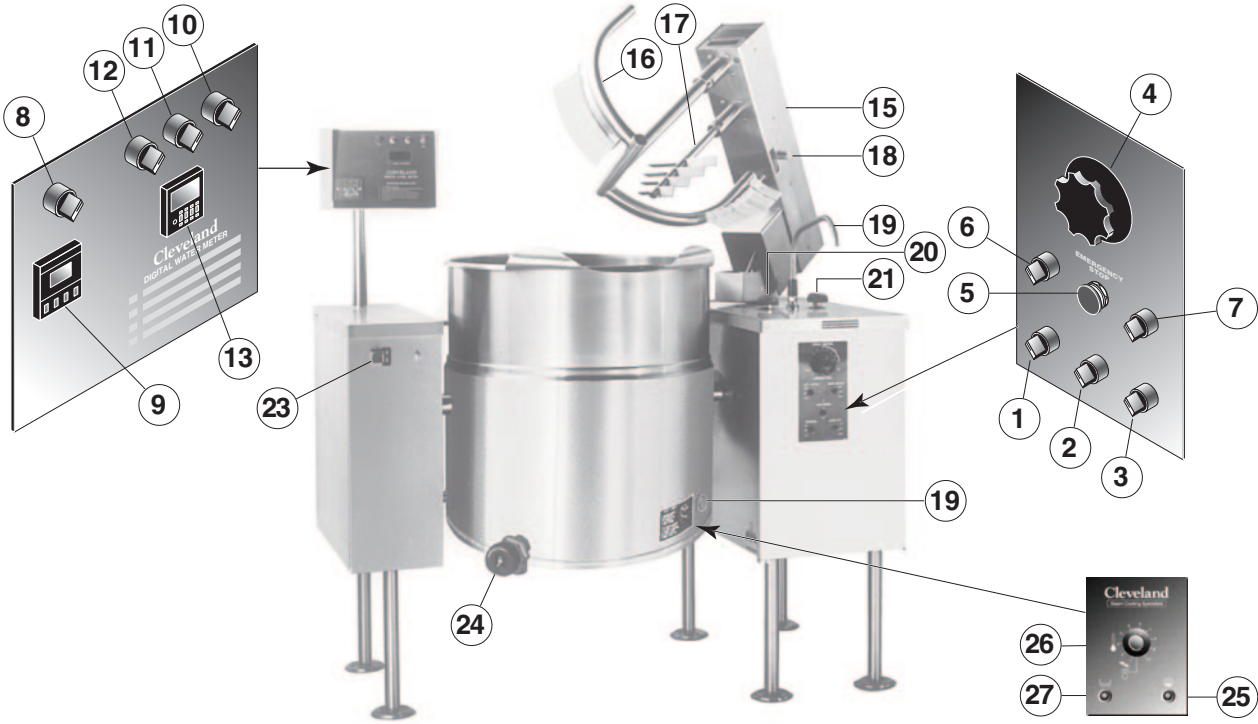

ITEM #	DESCRIPTION	FUNCTION
1.	MAIN POWER SWITCH	Power switch for unit.
2.	MIX/LIFT SWITCH	Sets hydraulics to mix or lift mode.
3.	UP/DOWN SWITCH	When unit is in lift mode, mixer bridge can be raised or lowered with this switch.
4.	MIXER SPEED CONTROL	Controls speed of agitators and mixer bridge lift.
5.	EMERGENCY STOP BUTTON	Stops hydraulic system (agitators and mixer bridge lift).
6.	HEAT/COOL SWITCH	Switches left hand kettle from heating to cooling.
7.	HEAT/COOL SWITCH	Switches right hand kettle from heating to cooling.
8.	ACTIVE/BYPASS SWITCH	Switch to activate or bypass (manual operation) the controller.
9.	TEMPERATURE CONTROLLER	Digital temperature control and indicator.
10.	WATER METER POWER SWITCH	Power switch for water meter.
11.	WATER METER START SWITCH	Starts water flow to kettle.
12.	WATER METER INTERRUPT SWITCH	Interrupts flow without resetting water meter.
13.	WATER METER CONTROL	Display and settings for water meter.
15.	MIXER BRIDGE	Encloses agitator motors.
16.	MAIN AGITATOR ARM	Provides most of the product movement.
17.	SECONDARY AGITATOR ARM	Provides reverse agitation and product lift in kettle.
18.	SECONDARY SPEED CONTROL KNOB	Controls speed of secondary agitator arm.
19.	FAUCET SPOUT	Delivers water to the kettle.
20.	HOT WATER VALVE	Turns on hot water.
21.	COLD WATER VALVE	Turns on cold water.
22.	VACUUM/PRESSURE GAUGE	Indicates steam pressure in PSI inside steam jacket as well as vacuum in inches of mercury.
23.	POWER TILT CONTROL SWITCH	Used for tilting the kettle up or down. Replaced by hand tilt wheel on manual tilt units.
24.	DRAW OFF VALVE	Discharge valve for product in the kettle.
25.	HEAT INDICATOR LIGHT (GREEN)	When lit, indicates that the kettle burner is on. Cycles ON-OFF with elements.
26.	SOLID STATE TEMPERATURE CONTROL KNOB	This control allows the operator to adjust the kettle temperature in increments from 1 (Min.) to 10 (Max.). (see Temperature Range Chart).
27.	LOW WATER INDICATOR LIGHT	When lit, indicates that the kettle is low on water and will not operate in this (Red) condition. This will also light when the kettle is tilted.

# OPERATING THE KETTLE



## Intended Use:

Processing of food and pharmaceuticals in non-residential locations. Not for the making of dough or other heavy dough like products.

## Intended Users:

- Supervised and trained staff during production periods.
- Trained maintenance and service personnel.

## Removable component weights

Lbs (kg)	40 gal	60 gal	80 gal	100 gal	125 gal	150 gal
Main arm with blades	21 (9.5)	23 (10.4)	25 (11.3)	28 (12.7)	32 (14.5)	32 (14.5)
Baffle arm	7 (3.2)	7 (3.2)	8 (3.6)	10 (4.5)	12 (5.4)	12 (5.4)
Secondary arm	8 (3.6)	8 (3.6)	10 (4.5)	12 (5.4)	13 (5.9)	13 (5.9)
Screen	7 (3.2)	8 (3.6)	9 (4.1)	10 (4.5)	14 (6.4)	14 (6.4)
Air valve complete			12 (5.4)			
Air cylinder only			8 (3.6)			
Air valve body only			4 (1.8)			

## Noise level

Noise level maximum 80 Decibels.

## Mixing Arm Rotation speeds

Arm	Speed (RPM)
Primary	0-40
Secondary	0-210

## Rim (loading) heights

Rim heights are given below. It is up to owners of the equipment to ensure the operators are performing the loading in a safe and acceptable manner.

Size	Height - BV3 valve	Height - PVA3 valve
40	40.5	40.75
60	43.75	44.25
80	44.75	46.26
100	44.5	48.75
125	44.5	48.75
150	48.5	53.5

## Emergency

In the event of a fire or other emergency.

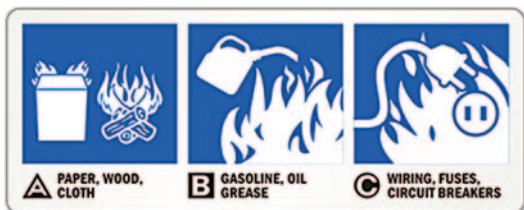

Turn off unit

Shut off power supplies including Electrical, Gas or Steam as applicable. (If safe to do so.)

Using fire extinguishers is only recommended if you are trained and feel safe to do so. Use only Fire extinguishers rated ABC.

This is a pressure vessel and with a properly operating safety valve will not exceed rated pressures. Jacket contains water and trace amounts of rust inhibitor and/or antifreeze.

## WARNING:



This unit has been fitted with a warning buzzer for bridge movement and a cover and screen to prevent contact with moving mixer arms. Do not remove or bypass these safeties.

1. Perform daily startup inspection.
2. Preheat the kettle by turning the ON/OFF Temperature Control to the desired temperature setting. The Heat Indicator Light (Green) will remain lit, indicating the burner is on, until the temperature setting is reached. When the green light goes off, the burners are off, and preheating is complete.

**NOTE:** When cooking egg and milk products, the kettle should not be preheated, as products of this nature adhere to hot cooking surfaces.

3. Place food product into the kettle. The green Heat Indicator Light will cycle on and off indicating the burners are cycling on and off to maintain the set temperature.



4. When cooking is completed turn Temperature Control to the "OFF" position.
5. Pour the contents of the kettle into an appropriate container by tilting the kettle forward or using discharge valve.

**NOTE:** Cleaning should be completed immediately after cooked foods are removed.

**NOTE:** A five minute complete shut-of period is required before relighting.

## Operating Suggestions

Cleveland Range Mixer Kettles are simple and safe to operate. The following tips will allow you to maximize the use of your new mixer.

If a mixer bridge is equipped with a temperature probe for a controller or thermometer, the probe must be submerged a minimum of three inches in the product for accurate readings.

## Safety

As a safety precaution the MIXER SPEED CONTROL must first be turned to zero before unit will start to mix.

Always remember, like a cooking pot the kettles become very hot when cooking. Avoid contact with bare skin.

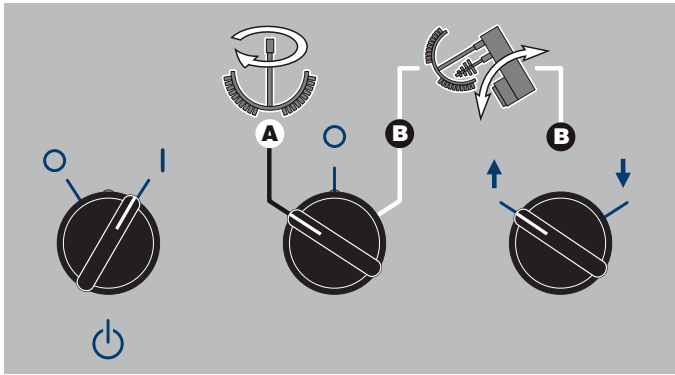

MAIN POWER SWITCH

MIX/LIFT SWITCH

UP/DOWN SWITCH

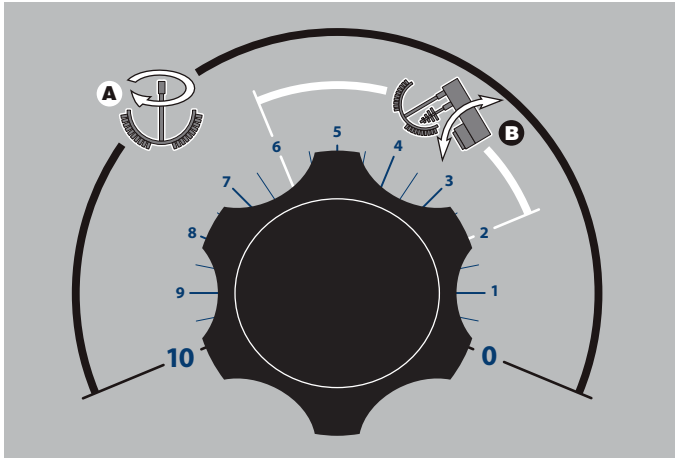

MIXER SPEED CONTROL SWITCH

## General Operation

1. Turn MAIN POWER SWITCH on.
2. Turn Steam Control Valve to control heat kettle.

## Lifting & Lowering Bridge

WARNING: Insure FAUCET SPOUT is out of way before raising or lowering bridge.

1. Turn MIX/LIFT SWITCH to lift icon "A".
2. Turn MIXER SPEED CONTROL to "0" and back up to "5".
3. Turn and hold UP/DOWN SWITCH to up arrow to raise or down arrow to lower.

## Mixing

1. Turn MIX/LIFT SWITCH to mix icon "B".
2. Turn MIXER SPEED CONTROL SWITCH to "0" and slowly adjust to desired speed.
3. Adjust SECONDARY SPEED CONTROL KNOB to desired speed.

## Tilting Kettle

1. Raise MIXER BRIDGE and swing to side.
2. For manual tilt: Turn HANDWHEEL.
3. For power tilt: Turn POWER TILT CONTROL SWITCH.

WARNING: Do not tilt kettle when mixer agitators are in kettle bowl.

## Product Discharge Valve

1. For butterfly valve: Push handle in and pull upwards to open.
2. For air valve: Turn Air Regulator Switch to open or close.

# CLEANING INSTRUCTIONS



## CARE AND CLEANING

Cooking equipment must be cleaned regularly to maintain its fast, efficient cooking performance and to ensure its continued safe, reliable operation. The best time to clean is shortly after each use (allow unit to cool to a safe temperature).

## WARNINGS



Chloride Cleaners

Do not use detergents or cleansers that are chloride based or contain quaternary salt.



Wire Brush & Scrapers

Do not use a metal bristle brush or scraper.



Steel Pads

Steel wool should never be used for cleaning the stainless steel.



High Pressure Spray Hose

Unit should never be cleaned with a high pressure spray hose.



Stagnant Water

Do not leave water sitting in unit when not in use.

## CLEANING INSTRUCTIONS

1. Turn unit off.
2. Remove drain screen (if applicable). Thoroughly wash and rinse the screen either in a sink or a dishwasher.
3. Prepare a warm water and mild detergent solution in the unit.
4. Remove food soil using a nylon brush.
5. Loosen food which is stuck by allowing it to soak at a low temperature setting.
6. Drain unit.
7. Rinse interior thoroughly.
8. If the unit is equipped with a **Tangent Draw-Off Valve**, clean as follows:
  - a) Disassemble the draw-off valve first by turning the valve knob counter-clockwise, then turning the large hex nut counter-clockwise until the valve stem is free of the valve body.
  - b) In a sink, wash and rinse the inside of the valve body using a nylon brush.
  - c) Use a nylon brush to clean tangent draw-off tube.
  - d) Rinse with fresh water.
  - e) Reassemble the draw-off valve by reversing the procedure for disassembly. The valve's hex nut should be hand tight only.
9. If the unit is equipped with a **Butterfly Valve**, clean as follows:
  - a) Place valve in open position.
  - b) Wash using a warm water and mild detergent solution.
  - c) Remove food deposits using a nylon brush.
  - d) Rinse with fresh water.
  - e) Leave valve open when unit is not in use.
10. If the unit is equipped with an **Air Valve**, clean as follows:
  - a) Open product valve.
  - b) Disconnect air hoses.
  - c) Remove air cylinder.
  - d) Remove valve tee.
  - e) Remove all O-rings.
  - f) Clean air cylinder, do not submerge in water. Wipe clean and sanitize.
  - g) Clean and sanitize tee and O-rings.
  - h) Grease and reinstall O-rings.
  - i) Reinstall valve tee to kettle outlet.
  - j) Reinstall air cylinder to bottom of tee.
  - k) Reconnect air hoses.
  - l) Close valve and check for alignment.
11. Clean the scraper blades as follows:
  - a) Remove retaining ring and slide scraper blades off agitator arm.
  - b) Place parts in a pan of warm water to soak.
  - c) Clean in a sink, using a warm water and mild detergent solution.
  - d) Rinse with fresh water.
  - e) Allow to dry thoroughly on a flat, clean surface.
12. Using mild soapy water and a damp sponge, wash the exterior, rinse, and dry.

## NOTES

- ⇒ For more difficult cleaning applications one of the following can be used: alcohol, baking soda, vinegar, or a solution of ammonia in water.
- ⇒ Leave the cover off when the kettle is not in use.
- ⇒ For more detailed instructions refer to Stainless Steel Equipment Care and Cleaning ([www.nafem.org/resources/stainlesssteelfinal.doc](http://www.nafem.org/resources/stainlesssteelfinal.doc)) on Nafem's website ([www.nafem.org](http://www.nafem.org)).

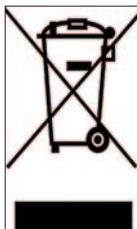

## DISPOSAL INSTRUCTIONS

This unit is recyclable. Do not dispose in landfill.

The unit may contain rust inhibitor and or antifreeze within the jacket. Drain unit and dispose following Federal, State and local regulations.

The majority of the unit is composed of stainless steel. Other alloys and electrical components make up a small percentage of the total. Follow Federal, state and local regulations for disposal.



# PREVENTATIVE MAINTENANCE

**FOR MAINTENANCE AND REPAIRS CONTACT YOUR AUTHORIZED MANITOWOC SERVICE AGENCY AND HAVE A QUALIFIED SERVICE TECHNICIAN MAINTAIN YOUR EQUIPMENT.**



## **WARNING:**

If for any reason this unit is not functioning correctly **DO NOT OPERATE**. Contact your authorized service agent.



## **DAILY PRE-STARTUP INSPECTION**

1. Kettle tilts smoothly, handle is tight and kettle holds in any position (tilting models only).
2. Pressure gauge is in the green when unit is cold.
3. Green light comes on when unit is energized.
4. Red light comes on when unit is tilted (tilting models only).

## **SIX MONTH SERVICE INSPECTION**

1. Perform daily startup inspection.
2. Gaskets are in good condition.
3. Tilt hand wheel is tight.
4. Grease bearings on both trunnions.
5. Check for play in gears (adjust if required).
6. Fasteners securing panels are in place and tight.
7. Perform pressure relief valve periodic test (see Pressure Relief Valve Testing).
8. Adequate exhaust and makeup air is supplied to working area.
9. Check for hydraulic leaks.
10. Check safety systems have not been bypassed.

## **YEARLY SERVICE INSPECTION**

1. Perform six month service inspection.
2. Replace hydraulic oil and filter.
3. Check kettle maximum temperature setting (see CALIBRATING PROCEDURE).
4. Perform safety inspection using SAFETY INSPECTION CHECKLIST found in the MAINTENANCE PROCEDURES.



# TROUBLESHOOTING AND MAINTENANCE PROCEDURES

*The following trouble shooting guide and maintenance procedures are meant to be used by Qualified Service Technician*



**ANY REPAIRS TO THE PRESSURE VESSEL MUST BE DONE BY A CERTIFIED PRESSURE VESSEL REPAIR SHOP AND ALL REPAIR METHODS AND MATERIALS MUST BE APPROVED BY THE MANUFACTURER.**

**For periodic maintenance recommendations see “Operators Manual”.**

**Extreme caution must be taken if unit is electrically energized for testing.**

**Remove power from the unit while servicing.**

## DIAGNOSTIC GUIDE

This section contains servicing information intended for use by Authorized Service Personnel.

**NOTE 1:** If Fault Isolation Procedure is required, be sure to start at step #1.

**NOTE 2:** On table type kettles the entire control mounting panel may be removed from kettle control housing for easier troubleshooting and parts replacement.

**A/ Problem:** Kettle is not heating at all. (Kettle must be on and temperature control set.)

### Possible Causes

- |                                    |  |  |
|------------------------------------|--|--|
| <b>1.</b> No incoming power.       | <b>5.</b> Defective 12 VDC relay.          | <b>10.</b> Defective thermistor.             |
| <b>2.</b> Kettle is tilted.        | <b>6.</b> Defective safety thermostat.     | <b>11.</b> Defective 240/16 VAC transformer. |
| <b>3.</b> Low water condition.     | <b>7.</b> Defective contactor/s.           | <b>12.</b> Defective control box.            |
| <b>4.</b> Defective ON/OFF switch. | <b>8.</b> Defective potentiometer.         | <b>13.</b> Defective elements.               |
|                                    | <b>9.</b> Defective low water level probe. |  |

### Fault Isolation Procedure

#### Step Test

<b>1.</b>	Is there proper incoming voltage at terminal block? Yes Go to step #2. No Correct external power supply problem.
<b>2.</b>	Is the red LED illuminated? Yes Follow Reservoir Fill Procedure. If this does not correct the problem, go to Problem <b>D</b> . No Go to step #3
<b>3.</b>	Is the green LED illuminated? Yes Go to step #4. No Go to step #7.
<b>4.</b>	Do both contactors energize? Yes Check contactor contacts for pitting. Voltage across contactor terminals while in a closed position indicates a poor contact. Replace contactor/s as necessary. Check elements for short at ground or an open circuit. If element/s are defective contact the factory. Elements are not field replaceable. No Go to step #5.
<b>5.</b>	Measure continuity across safety thermostat. Is it an open circuit? Yes Replace defective safety thermostat. No Go to step #6.
<b>6.</b>	Is there 120 VAC present across the coils of the contactors? Yes Replace defective contactor/s. No Go to step #7.
<b>7.</b>	Remove wire from low water level probe and ground it to the body of the kettle. Do the contactors now energize? Yes Clean or replace defective low water level probe. Replace defective red LED. No Go to step #8.
<b>8.</b>	Is there 16VAC present at output of 16 VAC transformer? Yes Go to step #9. No Replace defective 240/16 VAC transformer.

<b>9.</b>	Measure continuity of ON/OFF switch. Is it operating properly?
Yes	Go to step #10.
No	Replace defective ON/OFF switch.
<b>10.</b>	Unplug control box and measure the resistance across potentiometer. Is it approximately 0 ohms at maximum setting and 50,000 ohms at minimum?
Yes	Go to step #11.
No	Replace defective potentiometer.
<b>11.</b>	Remove edge connector from control box. While kettle is cold or thermistor is removed and allowed to cool, measure the resistance between edge connector's pins #2 and #7. Is it approximately 100,00 ohms?
Yes	Spray contact cleaner on control box terminals and edge connector. Try box again, if the problem still exists, replace defective control box.
No	Replace defective thermistor.

**B/ Problem:** Kettle heats too slowly or not hot enough. (**Note:** normal max. operating pressure with an empty kettle is 30-35 psi.)

**Possible Causes**

- |   |                                    |                                  |
|---|------------------------------------|----------------------------------|
| <b>1.</b> Air in jacket requires venting. | <b>3.</b> Defective potentiometer. | <b>6.</b> Defective control box. |
| <b>2.</b> Defective safety thermostat.    | <b>4.</b> Defective thermistor.    | <b>7.</b> Defective elements/s.  |
|   | <b>5.</b> Defective contactor/s.   |                                  |

**Fault Isolation Procedure**

Step	Test
<b>1.</b>	In a cold state, does the pressure gauge read in the green zone?
Yes	Go to step #2.
No	There is air present in the jacket of the kettle. Follow Kettle Venting Procedure. If constant venting is required, there is a leak that should be corrected.
<b>2.</b>	Do the contactors shut off too early? (before reaching normal maximum operating pressure.)
Yes	Go to step #3.
No	Check contactor contacts for pitting. Voltage across terminal of contactor while energized signifies a poor contact. Replace contactor/s as necessary. Check elements for short to ground or open circuit. If elements are defective, contact the factory. Elements are not field replaceable.
<b>3.</b>	Does the green LED remain illuminated after the contactors shut off?
Yes	Replace defective safety thermostat.
No	Go to step #4.
<b>4.</b>	Unplug control box and measure the resistance across potentiometer. Is it approximately 0 ohms at maximum and 50,000 ohms at minimum setting?
Yes	Go to step #5.
No	Replace defective thermistor.
<b>5.</b>	Remove kettle thermistor and allow to cool. Remove edge connector from control box. Test resistance across edge connector's pins #2 and #7. Is it approximately 100,000 ohms?
Yes	Go to step #6.
No	Replace defective thermistor.
<b>6.</b>	Turn the potentiometer on the control box clockwise to increase the maximum operating temperature. Does the kettle now achieve maximum operating pressure of 30-35 psi in an empty kettle?
Yes	Kettle is operating correctly.
No	Spray contact cleaner on control terminals and edge connector. Try box again. If problem still exists, replace defective control box.

**C/ Problem:** Kettle is overheating.

**Possible Causes**

- |                                    |                                   |
|------------------------------------|-----------------------------------|
| <b>1.</b> Defective thermistor     | <b>3.</b> Defective 12 VDC relay. |
| <b>2.</b> Defective potentiometer. | <b>4.</b> Defective control box.  |

**Fault Isolation Procedure**

Step	Test
<b>1.</b>	Does the green LED turn off even though the contactors remain energized?
Yes	Replace defective 12 VDC relay.
No	Go to step #2.

<b>2.</b>	Unplug the control box and measure the resistance across the potentiometer, Is the resistance approximately 0 ohms at maximum and 50,000 ohms at minimum setting?
Yes	Go to step <b>#3</b> .
No	Replace defective thermistor.
<b>3.</b>	Remove kettle thermistor and allow to cool Remove edge connector from control box. Test resistance across edge connector's pins #2 and #7. Is it approximately 100,000 ohms?
Yes	Go to step <b>#4</b> .
No	Replace defective thermistor.
<b>4.</b>	Turn the potentiometer on the control box counter-clockwise to decrease the maximum operating temperature. does the kettle continue to overheat?
Yes	Spray contact cleaner on control box terminal and edge connector. Try box again. If problem still exists, replace defective control box.
No	Kettle is operating correctly.

**D/ Problem:** Red LED remains illuminated even though water has been added.

**Possible Causes**

- 1.** Defective low water level probe
- 2.** Defective control box.

**Fault Isolation Procedure**

Step	Test
<b>1.</b>	Remove wire from low water level probe and ground the wire to the body of the kettle. Does the red LED turn off?
Yes	Replace or clean defective low water level probe.
No	Spray contact cleaner on control box terminals and edge connector. Try box again. If problem still exist, replace defective control box.

## SAFETY INSPECTION CHECKLIST

**NOTE:** The following instructions are intended for use by qualified service personnel. The following steps should be completed IN SEQUENCE.



### A/ KETTLE PREPARATION

- 1. Disconnect main power at fused disconnect switch.**
- 2.** Kettle should be cold. If necessary add water to kettle pot to cool unit.
- 3.** The pressure gauge should now show a vacuum and have no indication of leakage. If gauge looks damaged replace gauge.
- 4.** Gauge must be showing a vacuum prior to proceeding. If not check for leaks, and repair kettle prior to proceeding. Refer to REFERENCE SECTION (KETTLE VENTING INSTRUCTIONS).



Pressure Gauge in Vacuum.

### B/ MECHANICAL CHECKS

- 1.** Inspect controls, replace damaged seals, switches, LED's etc..
- 2.** Remove the console cover and check that the seal is not cracked or split. Replace seal, screws, missing or worn nylon anchor nuts. **Leave cover off.**
- 3.** Remove the kettle bottom cover and check that the seal is not cracked or split. **Leave cover off.**

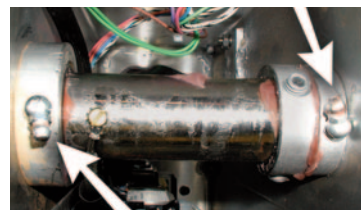

Grease Nipples.

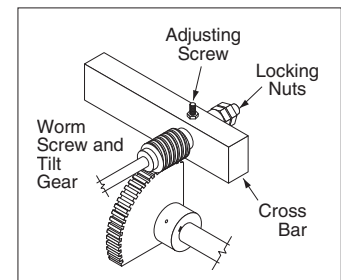
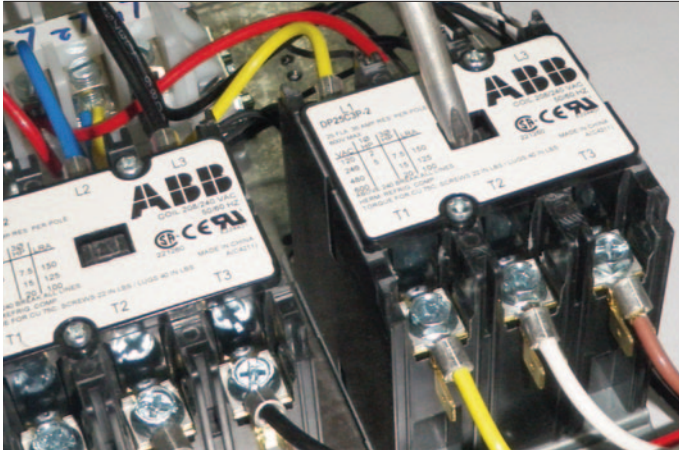

Illustration inverted for clarity.

**4. For units with tilt crank-**

- A. Check that the kettle tilts smoothly. If there is excess play adjust the worm to gear clearance with Locking Nuts or Adjusting Screw as required.
- B. Check that there is no excessive wear in the trunnion bearings.
- C. Apply grease to gear teeth and bearings.



## C/ CONTACTOR TEST

1. Remove power to unit.
2. Remove nut holding component mounting plate to console.
3. Pull plate out and place on top of console. (Depending on how the installer wired the kettle you may have to remove the supply wire and reconnect).
4. Physically push in on contacts of each contactor to check for free movement. Replace contactor(s) if required.

## D/ LOW WATER LEVEL PROBE:

### Installation Check:



✓ Probe properly attached

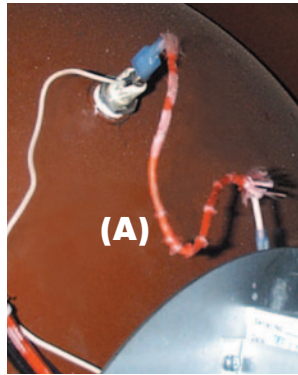

✗ Probe bypassed by running (A) an additional wire

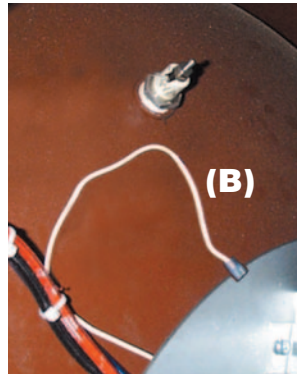

✗ Probe bypassed by (B) grounding the connecting wire

### Functional Test:

1. Turn main power on at fused disconnect switch.
2. Turn kettle on and set temperature to maximum.
3. Green light will come on and contactors close.
4. Tilt kettle over. After approximately a five-second delay the red light will come on, green light go off and the contactors will disengage.
5. Turn kettle upright. Green light will come back on and contactors reengage.
6. Turn kettle off
7. If unit does not function as above, make required repairs.
8. Disconnect main power at fused disconnect switch.

## E/ SAFETY THERMOSTAT

### Installation Check:

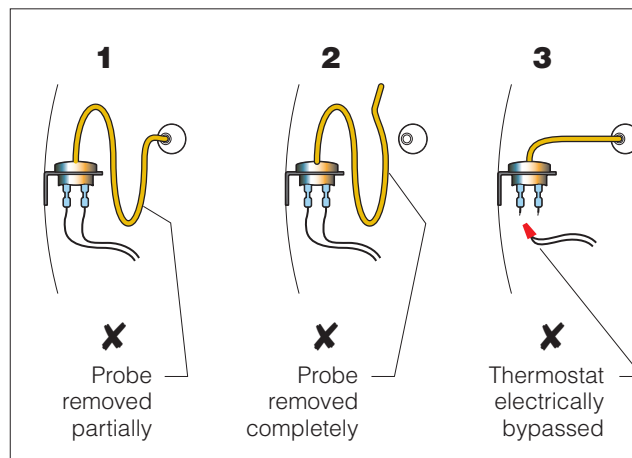
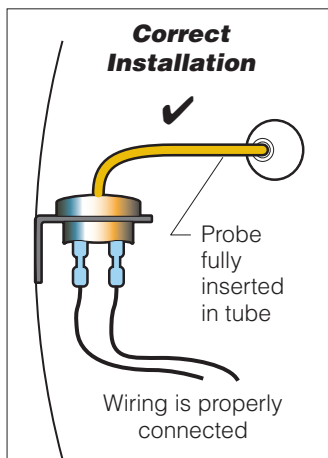

### Incorrect Installations

1. Safety thermostat probe is not completely inserted into tubing (except KET-3-T that has a small loop).
2. Safety thermostat probe is removed from tubing.
3. Safety thermostat electrical connection is bypassed.

## F/ SAFETY VALVE



### Installation Check:

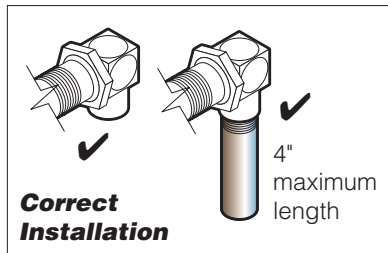

The above illustrations show the variations of factory installed Safety Valves. **Any modifications are unacceptable.**

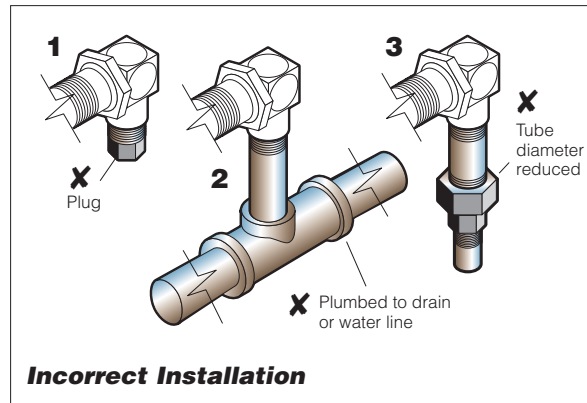

### Physical Checks

1. Check that the PSI rating on the valve matches MAWP (maximum allowable working pressure) on the plate welded to the kettle.
  2. Check that the Safety Valve has a "UV" stamp.
  3. Check that the valve is not damaged in any way.
- If any of the above criteria is not met, replace valve.

### Pressure Relief Valve Periodic Testing Procedure

1. With the kettle empty, set On-Off Switch/Temperature Control to "10" (Max.). Allow the kettle to heat until the unit cycles off.
2. Switch On-Off Switch/Temperature Control to "0" (Off) and disconnect main power at fused disconnect switch.
3. Stand to the side of the pressure relief valve discharge tube and pull valve open for a maximum of one second. Repeat test three to four times. Each time the mechanism should move freely and be accompanied by a rapid escape of steam.

If valve appears to be sticking replace pressure relief valve.

If foreign material is discharged then drain kettle and replace pressure relief valve.

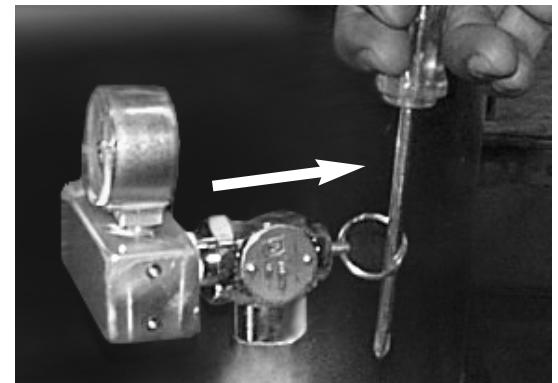

## G/ CALIBRATING PROCEDURE

1. Kettle must be empty when this procedure is executed.
2. Insure the unit has a vacuum before you begin calibrating procedures. If unit requires venting see REFERENCE SECTION (KETTLE VENTING INSTRUCTIONS).
3. Turn kettle ON and set temperature dial to 10 (Max.).
4. Allow the unit to cycle twice (the green light must go on and off).
5. Check temperature of the inner kettle surface with a digital surface thermometer. For accurate readings move probe around bottom of kettle to locate the hottest location.
6. Temperature should be between 260° F and 265° F. Pressure gauge should read between 20 - 28 PSI.
7. Using a screw driver adjust temperature by turning the potentiometer on the black box. Turn very little. Turn clockwise to INCREASES and counter-clockwise to DECREASE temperature.
8. Allow the unit to cycle twice.
9. Re-check temperature.
10. Repeat steps 7 - 9 until unit is calibrated.

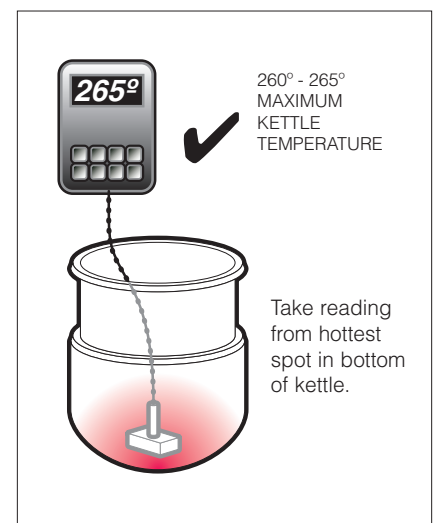

## REPAIRING LEAKS IN STEAM JACKETED KETTLE FITTINGS

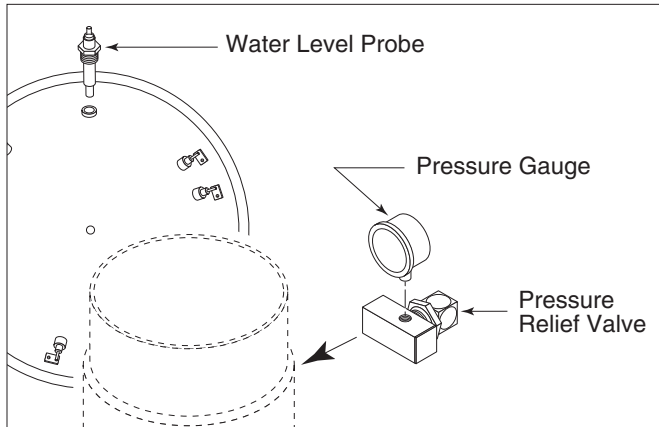

If unit will not hold a vacuum the most likely cause is a leak at one of the fittings. Often, the easiest way to eliminate a leak is reseal the suspect areas.

1. Water Level Probe      Remove, clean threads, apply teflon thread sealant and reinstall.
2. Pressure Relief Valve      **A/** Inspect for signs of leaks. Replace if required.  
    **B/** Remove, clean threads, apply teflon thread sealant and reinstall.
3. Pressure Gauge      **A/** Inspect face of gauge. If it contains moisture on the inside of face replace.  
    **B/** Remove, clean threads, apply teflon thread sealant and reinstall.

## THERMISTOR REPLACEMENT

1. Disconnect main power at fused disconnect switch.
2. Remove bottom cover.

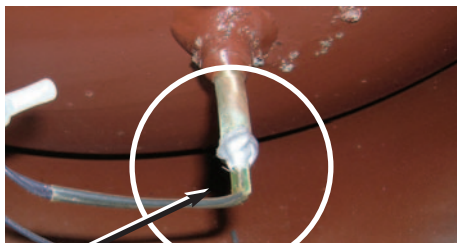

3. Locate thermistor.



4. Cut pigtail connection off.



5. Remove wire from ground lug.
6. Remove thermistor from tube.



7. Add new "eye" connector to one of the thermistor leads and fasten to ground lug.

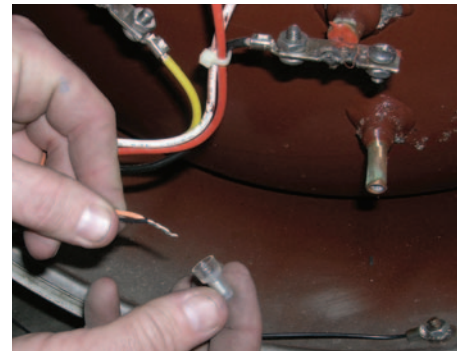

8. Connect orange wire to the other thermistor lead and fasten with pigtail connector.



9. Insert thermistor as far as possible into tube and hold in place. While holding add silicon to secure thermistor into tube. Insure silicon completely surrounds tube and thermistor.
10. Replace covers, reconnect power and test operation.

# KETTLE JACKET CLEANOUT AND PASSIVATION PROCEDURES

The following procedure should be performed at least once every three years to prevent possible corrosion and ensure the optimum life of the kettle.



**DANGER:**



Rust inhibitor can be dangerous. read label and follow safety instructions.

**WARNING:**



Improper refilling of kettle jacket will result in irreversible damage to unit.

## RUST INHIBITOR

Use a "radiator rust inhibitor" that can be purchased at your local automotive centre. It should not contain any anti-freeze and preferably no lubricant.

To ensure satisfactory mixing follow the manufacturer's instructions.

DISPOSAL - Follow all Federal, State and local codes when disposing of product.

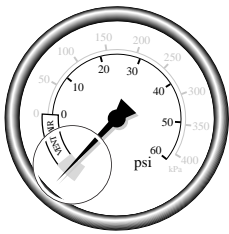

1. Ensure kettle is at room temperature and pressure gauge showing zero or less pressure.
2. Shut off power to the kettle at the fused disconnect switch.

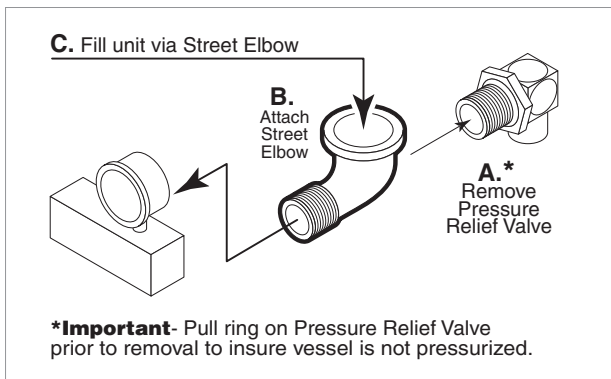

3. Pull Pressure Relief Valve (A) open to insure vessel is not pressurized.
4. Remove Pressure Relief Valve (A).
5. Replace Pressure Relief Valve (A) with Street Elbow (B).
6. Add Spring Water (C) through the Street Elbow (B), using a funnel if necessary. Refer to SPRING WATER REQUIREMENTS chart for the proper amount required.
7. Apply a thread sealant (i.e. Teflon tape) to the Pressure Relief Valve's (A) thread and replace.
8. Restore power to unit at the fused disconnect switch.
9. The kettle must now be vented. (Refer to the KETTLE VENTING INSTRUCTIONS).

## KETTLE VENTING INSTRUCTIONS

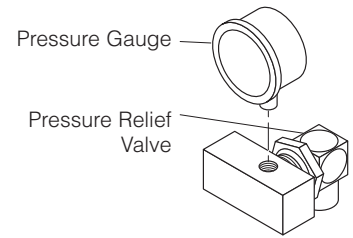
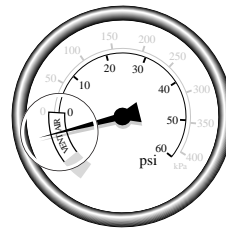

The following venting procedure should be followed when the Vacuum/Pressure Gauge needle is in the "VENT AIR" zone:

NOTE: Check for and eliminate leaks prior to venting (See REPAIRING LEAKS IN STEAM JACKETED KETTLE FITTINGS).

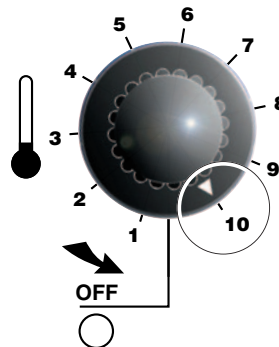

1. Set On-Off Switch/Temperature Control to "10" (Max.). Heat the empty kettle until unit cycles off.



2. Vent kettle by pulling safety valve ring 8-10 times in short 2-3 second blasts with a 5 second interval between pulls.

NOTE: If unit cycles ON, stop venting and wait for kettle to cycle OFF before continuing.

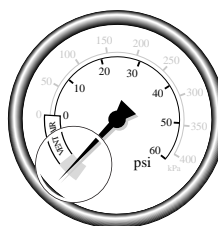

3. Turn kettle OFF. Add cold water to kettle until its surface temperature is below 100°F. The pressure gauge needle should be in the green zone, indicating a vacuum in the kettle's jacket.

## LUBRICATION PROCEDURE

Lubricate the following parts every three months to insure smooth operation and reduce wear.

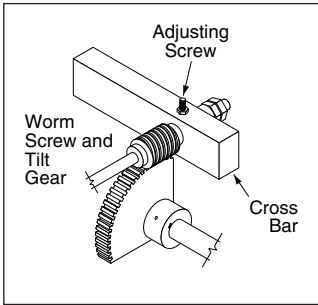

### TRUNNION HOUSING, WORM SCREW AND TILT GEAR

These parts are accessed through the top cover of the console.

Apply grease to gear teeth. Check for excessive play and adjust with adjusting screw located on top of cross bar.

### KETTLE TRUNNIONS

On the left hand side of the kettle there are two grease nipples on the top back portion of the trunnion housing. On the right hand side of the kettle you must remove the console cover to access the two grease nipples.

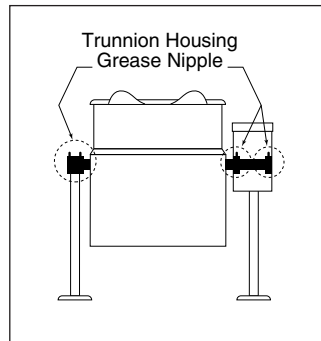

## HINGE ADJUSTMENT INSTRUCTIONS

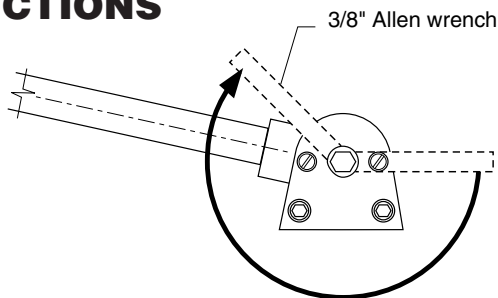

1. Insert 3/8" Allen wrench.
2. Turn clockwise to relieve tension on spring.
3. While tension is released remove one of the two slotted screws.
4. To prevent Allen wrench from springing back abruptly while the second slotted screw is removed, insert a pin (approximately 1/8") in the hole where the first slotted screw was removed from.
5. Remove second slotted screw.
6. While holding Allen wrench remove pin.
7. Turn Allen wrench clockwise to tighten or counter-clockwise to loosen tension to produce desired effect.
8. Re-insert pin in one of the two holes.
9. Tighten one slotted screw in the other hole (it may be necessary to turn Allen wrench slightly to align holes).
10. Remove pin and repeat step number 9 for other slotted screw.

## SSK SOLID STATE CONTROL TEST INSTRUCTIONS

**SSK Solid State Control** (part number [KE00458-1](#))

<b>SWITCH</b>	○	<b>SWITCH</b> - Push for 5 seconds to enter TEST #1 Press again for TEST #2 and again for TEST #3
<b>CPU</b>	○	<b>CPU</b> - Rapid flashing during normal operation TEST #1 = 1 flash/sec Water level test TEST #2 = 2 flash/sec Thermistor test TEST #3 = 3 flash/sec Heater Output test
<b>DIAGNOSTIC LED</b>	○	<b>TEST #1</b> GREEN Probe senses water RED No water sensed
		<b>TEST #2</b> GREEN Thermistor is sensed ORANGE Thermistor is shorted RED Thermistor is open circuit
<b>POTENTIOMETER</b>	○	
<b>LOW WATER</b>	○	
<b>HEATER OUTPUT</b>	○	<b>TEST #3</b> GREEN voltage output to relay for 20 seconds. Normal operation LED matches Front heater (green) LED

**THIS CONTROL BOX MUST BE CALIBRATED WHEN REPLACED**  
(see back for test and calibration instructions)

1. If required remove board from holding bracket for better access.
  2. Turn unit on and set to 10 (maximum).
  3. Push and hold the SWITCH button for approximately 5 seconds until the CPU starts to flash 1 flash/second. You are now in TEST #1. Output to 12v relay is disabled. With kettle upright the DIAGNOSTIC LED should be green, with kettle tilted it should be red.
  4. Push SWITCH button. The CPU starts to flash 2 flash/second. You are now in TEST #2. Check the DIAGNOSTIC LED for indication of the temperature probe status.
  5. Push SWITCH button. The CPU starts to flash 3 flash/second. You are now in TEST #3. The HEATER OUTPUT LED should light for 20 seconds and power to the relay should energize the 12v relay for the heat source.
- After 20 seconds test mode is exited and unit reverts to normal operation.

## RESERVOIR FILL PROCEDURES

The kettle's water level must be maintained at the proper level to submerge the heater elements. Under normal operating conditions, the sealed water reservoir should never require the addition of water.

If the red "low water" light comes on during use (while the kettle is in an upright position), the water level has reached a critically low level. The low water protection control has automatically shut off the heater elements. The following procedure must be completed before further use:

**NOTE:** Have a qualified service technician repair the leakage problem and add water to the unit. Ensure that the red "low water" light is on when the kettle is upright. On tilting kettles, it is normal for the red light to come on when the kettle is in a tilted position, as the elements are not submerged in water at this point.

**CAUTION:** Only a mixture of distilled water and rust inhibitor should be used when adding water to a partially filled water reservoir. Local tap water conditions may cause kettle damage which is not covered under warranty. Rust inhibitor is purchased locally. Read directions and do not exceed manufacturer's recommendation (excessive rust inhibitor can also cause solidification).

## SPRING WATER REQUIREMENTS

Kettle Capacity	When Red "Low Water Light" comes on, add Distilled Water	When the Reservoir is Completely Empty, Add Distilled Water
<b>3 gallon</b>	50 ounces	120 ounces
<b>6 gallon</b>	70 ounces	160 ounces
<b>12 gallon</b>	120 ounces	2 gallon
<b>20 gallon</b>	1 gallon	3 gallon
<b>25 gallon</b>	1.0 gallon	3.8 gallon
<b>30 gallon</b>	1.5 gallon	4.3 gallon
<b>40 gallon</b>	2.0 gallon	4.8 gallon
<b>60 gallon</b>	2.1 gallon	5.8 gallon
<b>80 gallon</b>	2.6 gallon	6.5 gallon
<b>100 gallon</b>	2.8 gallon	7.3 gallon

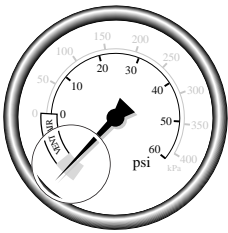

1. Ensure kettle is at room temperature and pressure gauge showing zero or less pressure.
2. Shut off power to the kettle at the fused disconnect switch.

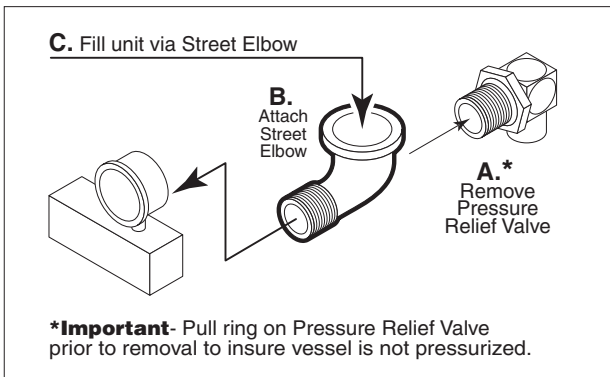

3. Pull Pressure Relief Valve (A) open to insure vessel is not pressurized.
4. Remove Pressure Relief Valve (A).
5. Replace Pressure Relief Valve (A) with Street Elbow (B).
6. Add Spring Water (C) through the Street Elbow (B), using a funnel if necessary. Refer to SPRING WATER REQUIREMENTS chart for the proper amount required.
7. Apply a thread sealant (i.e. Teflon tape) to the Pressure Relief Valve's (A) thread and replace.
8. Restore power to unit at the fused disconnect switch.
9. The kettle must now be vented. (Refer to the KETTLE VENTING INSTRUCTIONS).

## DRAINING PROCEDURE



**WARNING:** THE FUSED DISCONNECT SWITCH MUST BE OFF BEFORE REMOVING THE KETTLES BOTTOM COVER.

### Draining procedure

1. Pull pressure relief valve to insure there is no pressure within the kettle jacket.
2. Remove bottom covers.
3. Remove low water level probe and allow water to drain.
4. To rinse kettle jacket:
  - a) On tilting kettles fill jacket from low water probe fitting.
  - b) On stationary kettles:
    1. Replace low water probe.
    2. Remove pressure relief valve and replace with street elbow.
    3. Using a small funnel (one made of paper works great) slowly pour water into the kettle.
5. Allow kettle to drain again.
6. Repeat until water drains clear.

## REFILLING UNIT

1. Apply a thread sealant (i.e. Teflon tape) to the water level probe threads and replace.

## LUBRICATION

Lubricate the following parts every three months to insure smooth operation and reduce wear.

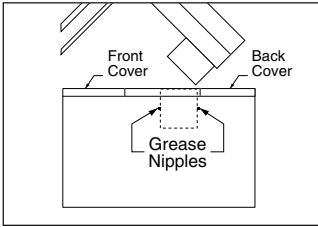

### MIXER BRIDGE HOUSING

There are two grease nipples on the mixer bridge swivel housing which are accessed by removing the front and back covers on the 18" console.

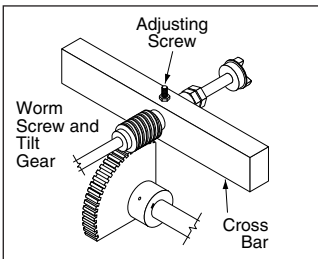

### TRUNNION HOUSING, WORM SCREW AND TILT GEAR

These parts are accessed through the front cover on the 18" console.

Apply grease to gear teeth. Check for excessive play and adjust with adjusting screw located on top of cross bar.

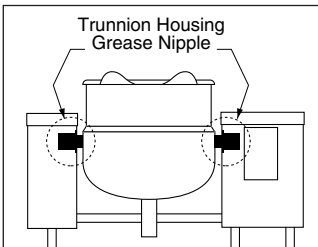

### KETTLE TRUNNIONS

Accessed via the top covers on the 10" and 18" consoles. Each has two grease nipples.

## HYDRAULIC OIL REPLACEMENT PROCEDURE

One of the most important maintenance tasks is to change the hydraulic oil yearly. Under heavy usage the oil should be changed every nine months. It is important to change the oil regularly to prevent its breakdown which leads to the damaging of components.

The oil filter should be changed at the same time as the hydraulic oil. A clean filter prevents particles from damaging the other components in the system.

*Replace the hydraulic fluid as follows:*

- ⇒ Disconnect power to unit.
- ⇒ Remove the front top panel on the main console.
- ⇒ Remove chrome vent cap from breather pipe located beside electric motor.
- ⇒ Remove plug bolt from bottom left front corner of main console to drain oil into your catch pail.
- ⇒ Remove oil filter.
- ⇒ Replace plug bolt.
- ⇒ Refill unit through breather pipe using approximately 12 U.S. gallons of Tellus 32 hydraulic oil (oil should be 6 1/2" deep in tank).
- ⇒ Install new oil filter (Part# SE50094).
- ⇒ Replace chrome vent cap and front top panel.
- ⇒ Reconnect power to unit.
- ⇒ Run unit to remove any air in the lines.

**NOTE:** Mixer may run rough and noisy for one or two hours if air has become trapped in the line.

## RE-INSTALLING SPEED CONTROL CABLE

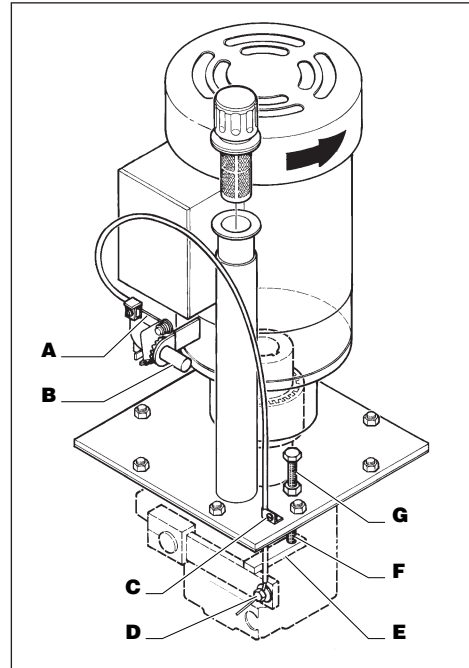

1. Turn sprocket of speed control so that wire "A" is fully extended towards shaft "B".
2. Insert end of cable through bracket "C".
3. Insert wire so it protrudes approximately 1/2" to 5/8" through hole in bolt "D". Tighten bolt and bend end of wire.
4. Bring pump arm "E" up until it hits stop bolt "F" and tighten screw "C".
5. Reassemble unit. Speed control knob will go on pointing toward minimum setting.
6. Turn mixer on with speed control set at minimum setting.
7. If scraper arm is turning, loosen nut "G" and back stop bolt "F" off a few turns. Next loosen screw "C" and slowly pull up cable until scraper arm stops turning. Retighten screw "C". Gently turn stop bolt "F" down until it hits arm. Lock in place by tightening nut "G".
8. Scraper arm should now go from no rotation to fast rotation by turning speed control knob.

**NOTE:** Mixer may run rough and noisy for one or two hours if air has become trapped in the line.

## AIR LINE LUBRICATOR OIL FILLING PROCEDURE

1. Disconnect air supply and bleed system.
2. Remove cover on console
3. Check for oiler location.
4. Inspect oil level in bowl.
5. Remove filler cap.
6. Add mineral oil as required.
7. Replace filler cap and console cover.

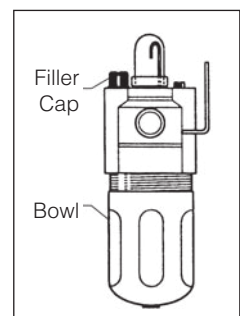

# WIRING DIAGRAM SINGLE KETTLES

(consult factory for other wiring configurations)

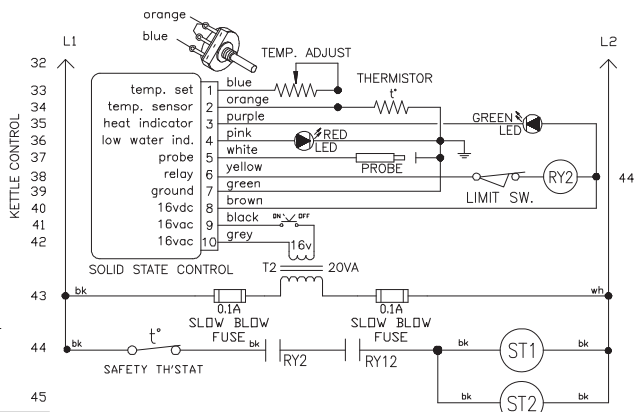
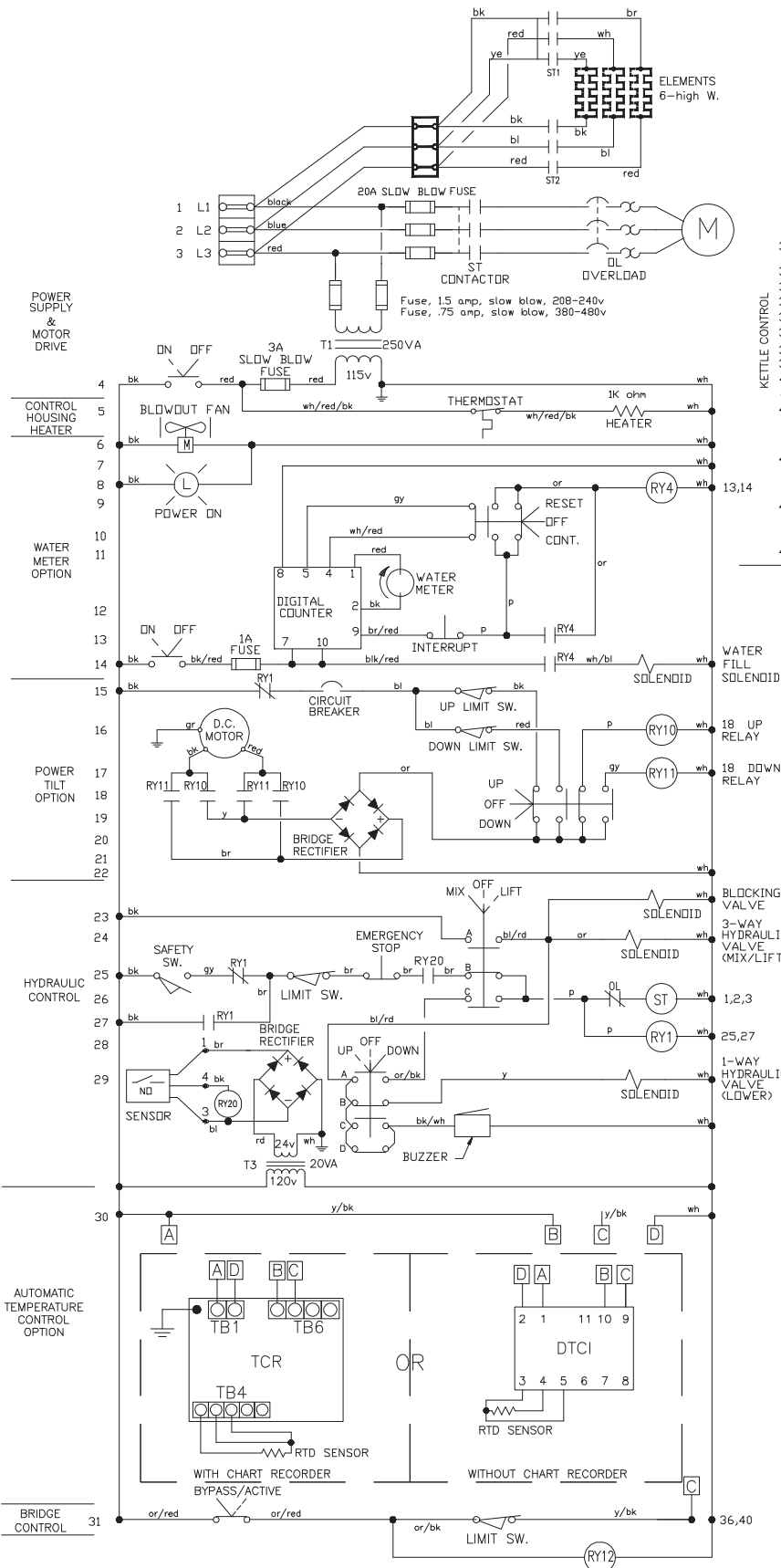

KE90417-5 0  
ELECTRIC MIXER KETTLE  
(ALL OPTIONS) 208-240 volts



# FLOW PATH FOR HYDRAULIC SYSTEM

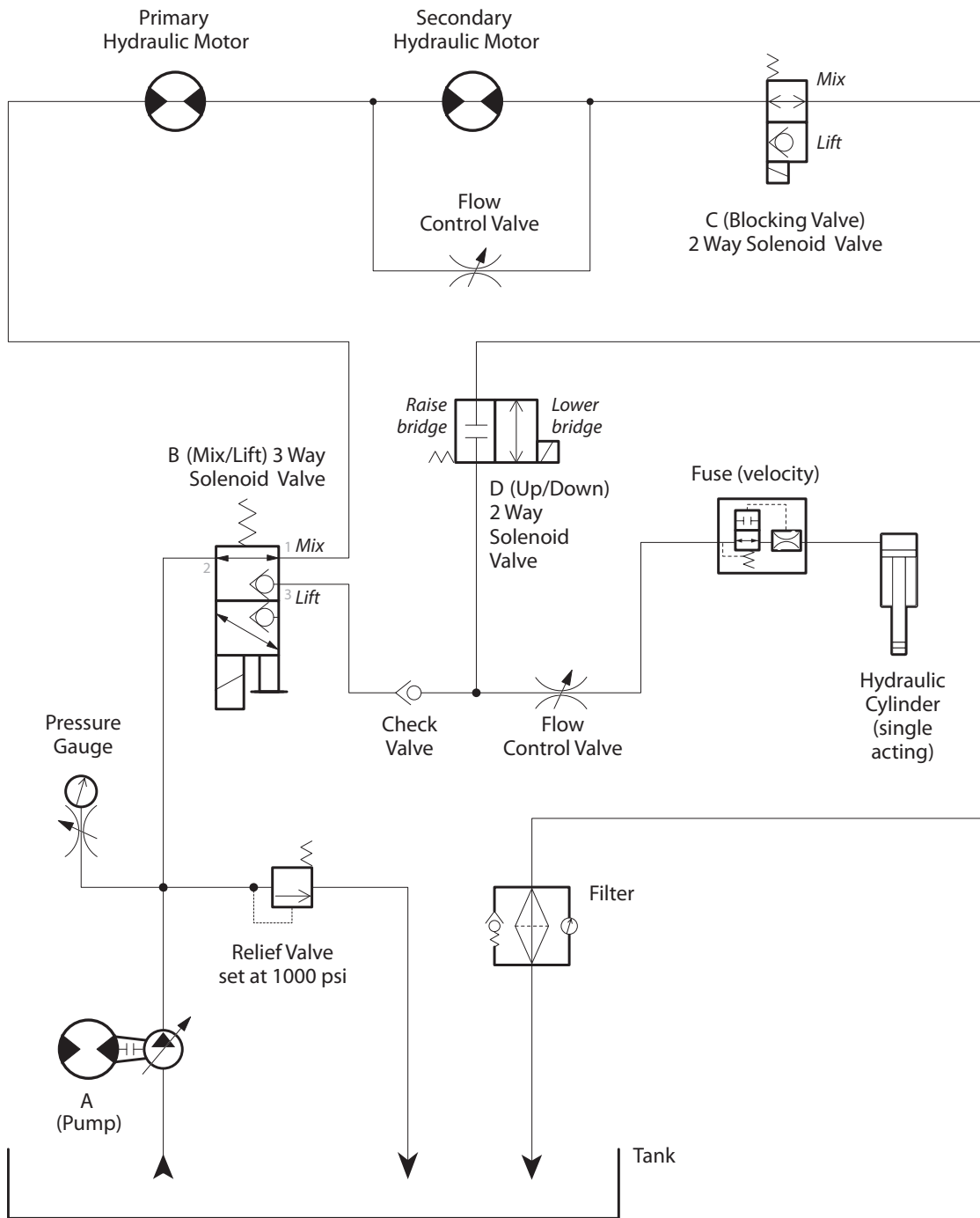

Switch	Position	Valve Energized			
		A (Pump)	B (Mix/Lift)	C (Blocking Valve)	D (Up/Down)
Lift/Mix	Mix	X			
	Off				
	Lift		X	X	
Up/Down	Up	X			
	Off				
	Down				X

# SERVICE PARTS

## WARRANTY

Our Company supports a worldwide network of Maintenance and Repair Centers. Contact your nearest Maintenance and Repair Centre for replacement parts, service, or information regarding the proper maintenance and repair of your cooking equipment

In order to preserve the various agency safety certification (UL, NSF, ASME/Ntl. Bd., etc.), only factory-supplied replacement parts should be used. The use of other than factory supplied replacement parts will void warranty.

## HYDRAULIC COMPONENTS

(page 1 of 2)

### Supply Fuses:

KE003844

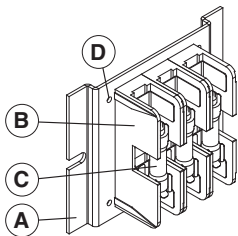

ITEM NO.	PART NO.	DESCRIPTION	QTY.
A.	KE50343-12	Fuse Mounting Plate	1
B.	KE51139-1	Fuse Holder	3
C.	KE52936-21	Fuse, 20A/600V/ KLDR20; Slow Blow	3
D.	FA15018-3	8-32x1/4" Phil Pan Head Screw	4

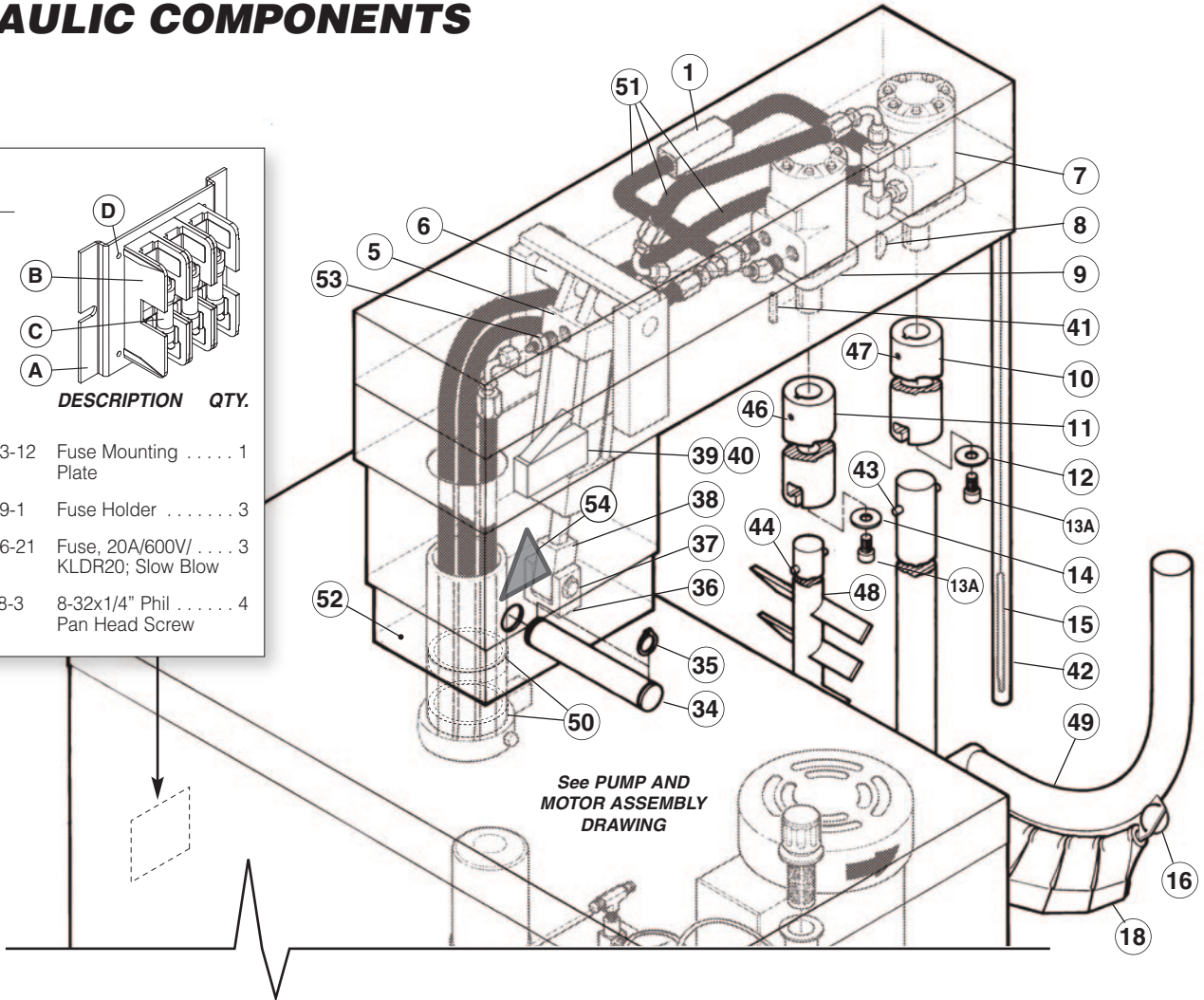

### Scraper Blades:

KE651834



KETTLE SIZE - GAL.	QUANTITY
40	22
60	26
80	30
100	34
125	38
150	38

### Baffle Arms:

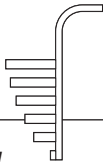

KETTLE SIZE - GAL.	PART NO.
40	KE01682-1
60	KE01682-2
80	KE01682-3
100	KE01682-4
125	KE01682-5
150	KE01682-6

### Cooling Fan:



Fan	KE54860
Fan Cover	KE601236
Fan Guard	KE54861

### Buzzer:

KE603849



NOTE: For Hydraulic Hoses order Part No. RT00505 and specify length required

# HYDRAULIC COMPONENTS (page 2 of 2)

ITEM NO.	PART NO.	DESCRIPTION	QTY.
1.	KE51607	Flow Control Valve . . . . .	2
5.	KE51848	Jack . . . . .	1
6.	KE52124-1	Jack Upper Pin . . . . .	1
7.	KE51846	Hydraulic Motor, Scraper Arm, 40 gal. . . . .	1
	KE51938	Hydraulic Motor, Scraper Arm, 60-150 gal. . . . .	
8.	FA95006	Woodruff Key . . . . .	1
9.	KE603736	Hydraulic Motor, Secondary Agitator, 40-150 gal. . . . .	
10.	KE51715	Main Coupling, Scraper Arm . . . . .	1
11.	KE51716	Secondary Coupling, Agitator Arm . . . . .	1
12.	KE603853-1	Coupling Washer, Primary S.S. . . . .	1
13A.	FA11286	Socket Head Screw, 1/4 X 20 . . . . .	2
14.	KE603853-2	Coupling Washer, Secondary S. S. . . . .	1
15.	CT50097	R.T.D. Probe Single (optional) . . . . .	1
16.	KE53962	Blade Stop Ring . . . . .	2
18.	KE51834	Scraper Blades . . . . . as required	
34.	KE51622	Bridge Tilt Pin . . . . .	1
35.	FA95007-10	Retaining Ring . . . . .	1
36.	KE51623	Clevis Bracket . . . . .	1
37.	SE50353	Clevis Pin c/w Clips . . . . .	1
38.	KE51624	Knuckle Joint . . . . .	1
39.	KE602764	Mounting Clip, Limit Switch . . . . .	
40.	SK2474500	Limit Switch . . . . .	1-2
41.	FA95055-3	Square Key . . . . .	1
42.	T40527	Housing, probe, 40 gal. . . . .	1
	T40528	Housing, probe, 60 gal. . . . .	1
	T40529	Housing, probe, 80 gal. . . . .	1
	T40530	Housing, probe, 100 gal. . . . .	1
	T40531	Housing, probe, 125 gal. . . . .	1
	T40532	Housing, probe, 150 gal. . . . .	1
43.	KE51921	Pin, Scraper Arm . . . . .	1
44.	KE51925	Pin, Secondary Agitator . . . . .	1
46.	FA19506	Set Screw, Secondary Agitator . . . . .	1
47.	FA19507	Set Screw, Scraper Arm . . . . .	1
48.	KE00935	Secondary Agitator, 40 gal. (includes #44) . . . . .	1
	KE00936	Secondary Agitator, 60 gal. (includes #44) . . . . .	1
	KE00937	Secondary Agitator, 80 gal. (includes #44) . . . . .	1
	KE00938	Secondary Agitator, 100 gal. (includes #44) . . . . .	1
	KE00939	Secondary Agitator, 125 gal. (includes #44) . . . . .	1
	KE00940	Secondary Agitator, 150 gal. (includes #44) . . . . .	1
49.	KE00947	Primary Agitator, 40 gal., with Gallon Markings (includes #16, 18 & 43) . . . . .	1
	KE00948	Primary Agitator, 60 gal., with Gallon Markings (includes #16, 18 & 43) . . . . .	1
	KE00949	Primary Agitator, 80 gal., with Gallon Markings (includes #16, 18 & 43) . . . . .	1
	KE00950	Primary Agitator, 100 gal., with Gallon Markings (includes #16, 18 & 43) . . . . .	1
	KE00951	Primary Agitator, 125 gal., with Gallon Markings (includes #16, 18 & 43) . . . . .	1
	KE00952	Primary Agitator, 150 gal., with Gallon Markings (includes #16, 18 & 43) . . . . .	1
	KE00947-1	Primary Agitator, 40 gal., with Liter Markings (includes #16, 18 & 43) . . . . .	1
	KE00948-1	Primary Agitator, 60 gal., with Liter Markings (includes #16, 18 & 43) . . . . .	1
	KE00949-1	Primary Agitator, 80 gal., with Liter Markings (includes #16, 18 & 43) . . . . .	1
	KE00950-1	Primary Agitator, 100 gal., with Liter Markings (includes #16, 18 & 43) . . . . .	1
	KE00951-1	Primary Agitator, 125 gal., with Liter Markings (includes #16, 18 & 43) . . . . .	1
	KE00952-1	Primary Agitator, 150 gal., with Liter Markings (includes #16, 18 & 43) . . . . .	1
50.	KE52687	Roller Bearing . . . . .	2
	KE52704	Thrust Washer, Brass . . . . .	2
51.	RT00505	Hydraulic Hose . . . . . specify length	
52.	KE00715	Bridge Swivel Housing Assembly . . . . .	1
53.	KE603842	Velocity Fuse . . . . .	1
54.	KE603825	Label, Hand Crush Warning . . . . .	1

# PUMP AND MOTOR ASSEMBLY

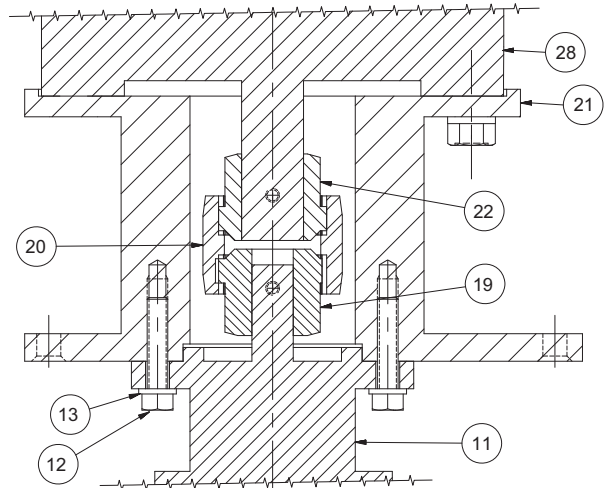
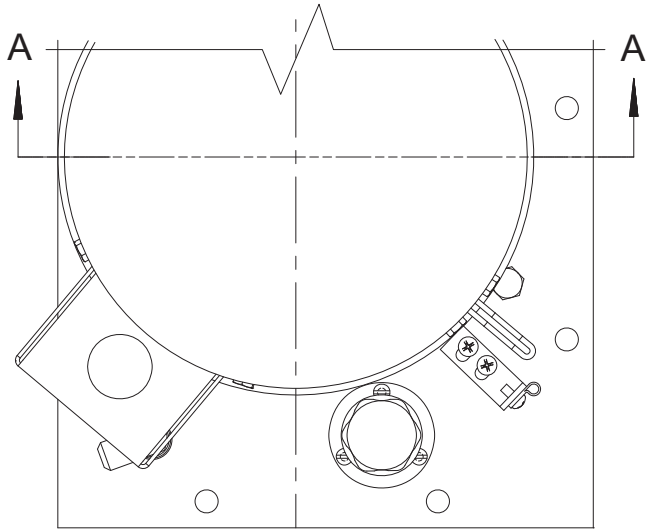

SECTION A-A

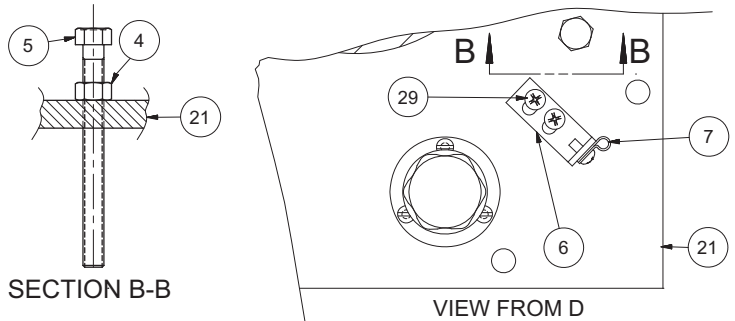

SECTION B-B

VIEW FROM D

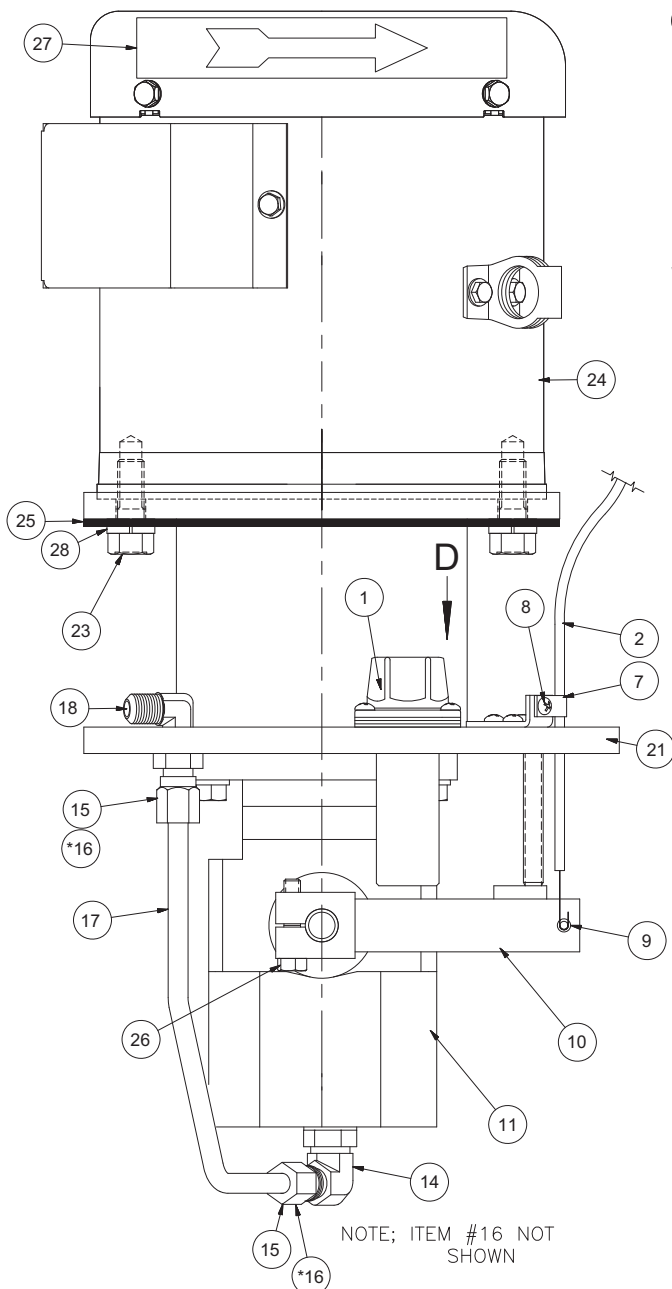

NOTE: ITEM #16 NOT SHOWN

ITEM	QTY	PART NUMBER	DESCRIPTION
1	1	KE51889	FILTER & TANK BRETHER
2	1	KE00860	SPEED CONTROL CABLE & BRACKET ASS"Y
4	1	FA20030	HEX NUT 3/8-16
5	1	FA10747	HEX. HEAD BOLT 3/8-16 X 4" LG.
6	1	KE603833	BRACKET
7	1	KE52050	CABLE CLAMP ARENS #MT304-3
8	1	FA11091	#8-32 X 3/8 S.S. Machine Screw
9	1	KE52049	CONNECTOR FITTING, ARENS #FT 319-1
10	1	KE00737	PUMP HANDLE ASSEMBLY
11	1	KE51844	HYDRAULIC PUMP.
12	2	FA11386	HEX BOLT 3/8-16 x 1 1/2 LG.
13	2	FA31010	SPLIT LOCK WASHER 3/8
14	1	FI05059	ELBOW 90°, AEROQUIP #2062-8-6
15	2	FI05079	NUT, AEROQUIP #FC2875-6
16	2	FI05080	FERRULE, AEROQUIP #FF9605-6
17	1	KE52048	HYDRAULIC TUBING
18	1	FI05072	BULKHEAD 90° UNION ELBOW
19	1	KE52222-1	METAL GEAR, 3/4 BORE
20	1	KE52224	PLASTIC GEAR COUPLING
21	1	KE00698	PUMP MTG. PEDESTAL
22	1	KE52222-2	METAL GEAR, 1 1/8 BORE
23	4	FA11509-2	HEX HEAD BOLT, S.S. 1/2-13 X 1 1/4 LG.
24			SEE MOTOR OPTIONS
26	1	FA10606	HEX HEAD BOLT, 15/16-18 X 1 1/4 LG
27	1	KE95265	LABEL, DIRECTION OF MOTOR ROTATION
28	4	FA31033	SPLIT LOCK WASHER, S.S. 1/2
29	2	FA11146	PAN PHIL M/S, S.S. 10-32 X 1/2 LG.
24			MOTOR OPTION.
	1	KE51875-3	MOTOR. VOLTAGE: 208-230/460/3/60
	1	KE51875-4	MOTOR. VOLTAGE: 220-380/440/3/50
25	1	KE52171	GASKET, OIL TANK

# HYDRAULIC FLOW CONTROL HARNESS

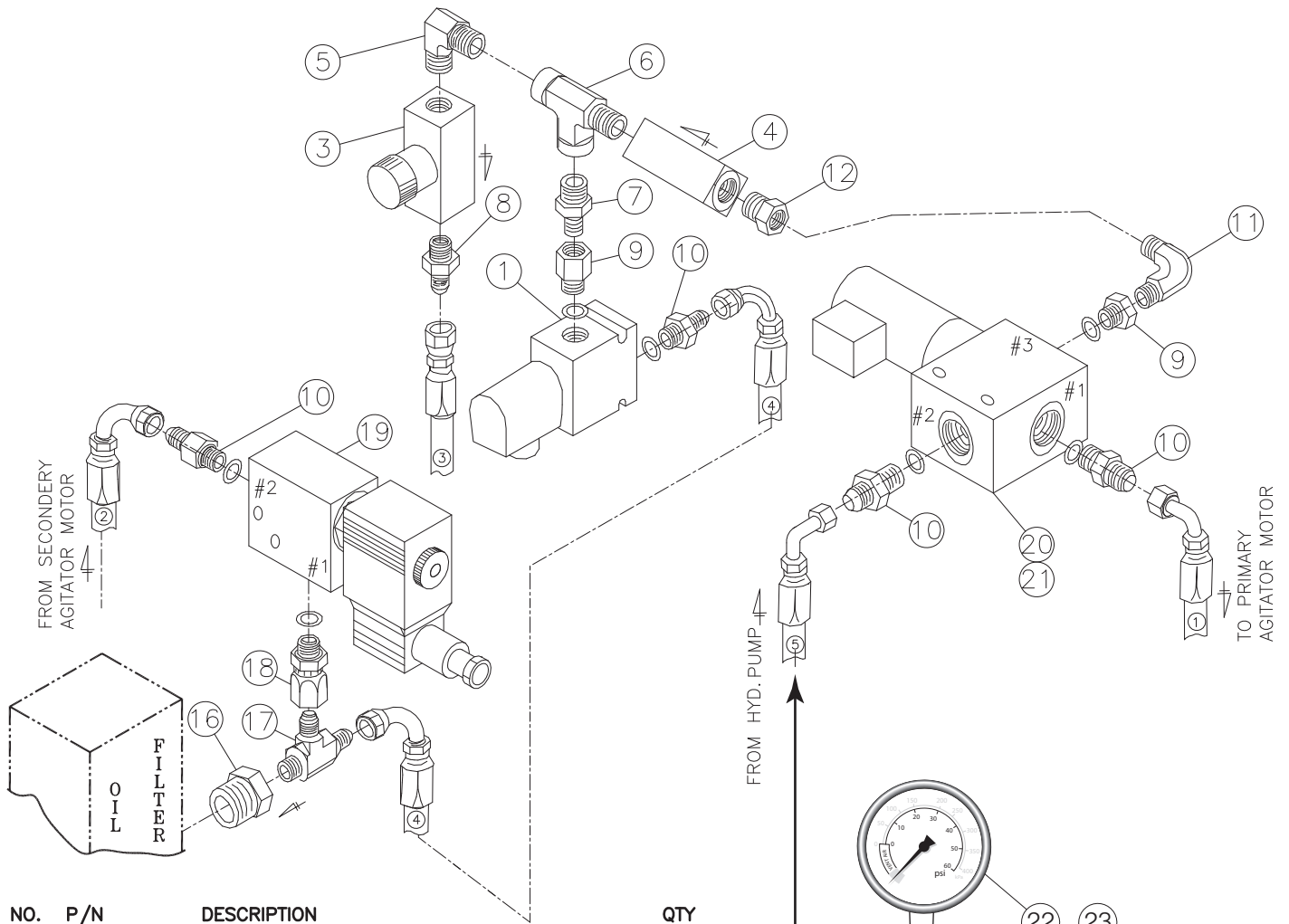

NO.	P/N	DESCRIPTION	QTY
1	KE54834-10	SOLENOID VALVE 3/8 BRASS	1
3	KE51607	NEEDLE VALVE	1
4	KE51608	CHECK VALVE	1
5	FI05030	ELBOW, 90°, 3/8	1
6	FI05031	TEE, STREET	1
7	FI05032	NIPPLE, MALE PIPE	1
8	FI05033	MALE ADAPTOR	1
9	FI05034	STRAIGHT THREAD ADAPTOR	2
10	FI05035	STRAIGHT THREAD ADAPTOR	4
11	FI05036	ELBOW, 90°, 1/4	1
12	FI05037	3/8 TO 1/4 REDUCER	1
16	FI05068	REDUCER, 3/4 TO 9/16 NPT	1
17	FI05056	TEE, 9/16 NPT TO JIC	1
18	KE603738	FITTING #6 PIPE SWIVEL/ #6 O-RING	1
19	KE603803	SOL. VALVE, I.H.# S201NH 110-65 N.O.	1
20	KE54834-16	3-WAY SOLENOID VALVE	1
21	KE603873	SOLENOID VALVE CONNECTOR (HIRSCHMAN)	1
	KE01700	PRESS RELIEF VALVE ASSEMBLY	1 (per kettle)
22.	<a href="#">KE52382</a>	PRESSURE GAUGE; LIQUID FILL	1
23.	<a href="#">KE51874</a>	PRESSURE RELIEF VALVE	1
24.	FI05054	MALE BRANCH TEE FITTING	1
25.	FI05069	STREET TEE	1
26.	FI05034	STRAIGHT THREAD ADAPTER	2
27.	FI05030-1	ELBOW; 3/8-1 1/4 - 90 DEG.	1

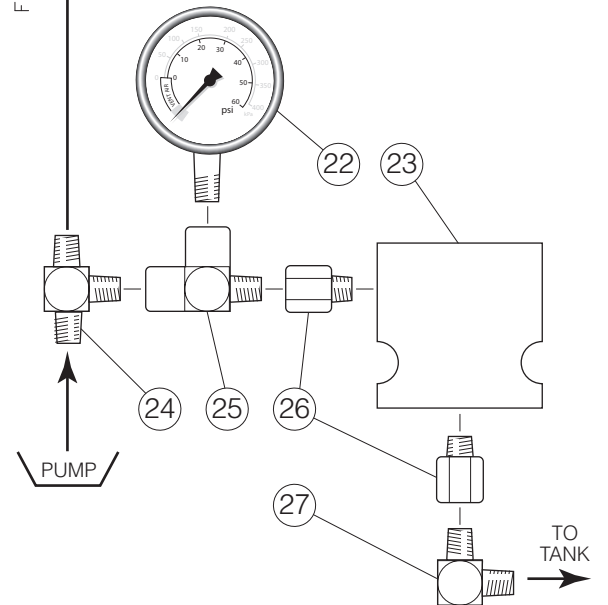

# TEMPERATURE CHART RECORDER BOX ASSEMBLY

MKDL-T / TMKDL-T / MKGL-T / HA-MKGL

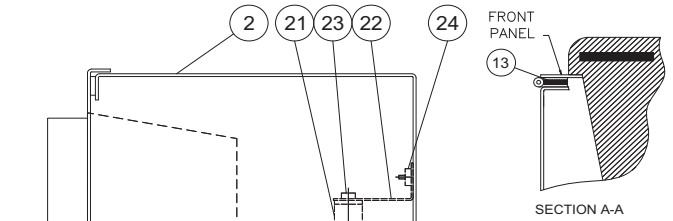
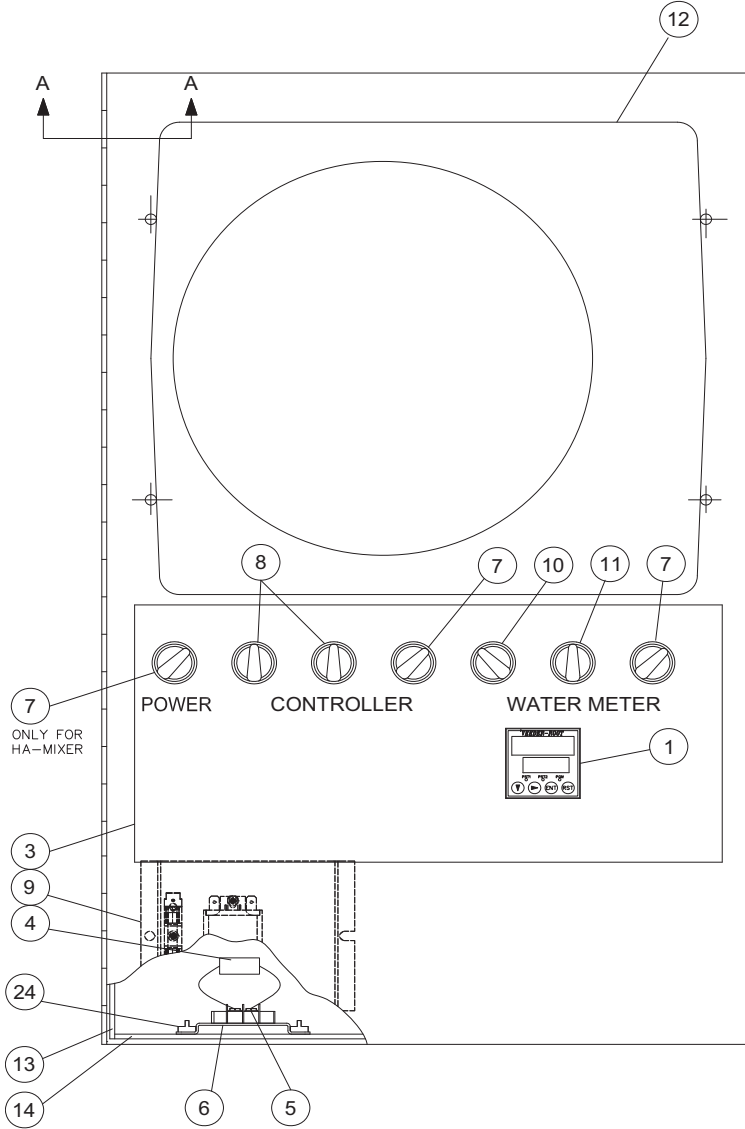

ITEM	PART #	DESCRIPTION	COMMON PARTS			
			HA-MIXER	VERTICAL MIXER	SINGLE HEAT-COOL	TWIN HEAT-COOL
1	KE53257	DIGITAL COUNTER				1
2	KE01354	TCR BOX WELDMENT	1	1		
3	KE95438	LABEL	1	1		
4	KE01820	AMBIENT HEATER ASSEMBLY	1	1		
5	SK50370-1	TERMINAL BLOCK; 2 SECTIONS	1	1		
6	KE54402	MOUNTING BRACKET	1	1		
7	KE003209-1	SWITCH ON/OFF-MAINTAINED	1	1	1	1
8	KE003209-3	SWITCH ON/OFF/ON-MAINT. (HEAT/COOL CONTROL)			1	2
9	REF.KE003736	COMPONENT PLATE ASSEMBLY	1	1		
10	KE003209-6	SWITCH ON/OFF-SPR. RETURN MOMENT.				1
11	KE003209-7	SWITCH ON/OFF-SPR. RETURN MOMENT. L/R				1
12	KE53136-1	CHART RECORDER (TCR-DTC)/TEMPERATURE CONTROLLER	1	1		
13	KE53131	GASKET STRIP 1/2 X 1/8 X 24 1/4	2	2		
14	KE53132	GASKET STRIP 1/2 X 1/8 X 15 3/4	2	2		
18*	NPN00020	CA TIE HOLDER; ADHESIVE BACK	25	25		
19*	SK50370-2	45 DEG TABS CURTIS; TERMINAL BLOCK	4	4		
20*	SK50370-3	90 DEG TABS CURTIS; TERMINAL BLOCK	4	4		
21	KE52710	THERMOSTAT	1	1		
22	KE603924	BRACKET FOR THERMOSTAT	1	1		
23	FA20504-1	"K" LOCKNUT ZINC	1	1		
24	FA21006	10-24 HEXAGON NUTS	3	3		

\* NOTE: PARTS NOT SHOWN ON DWG.

KE003730A

PART NUMBER	SWITCH KE603208-1	SWITCH KE603208-2	SWITCH KE603208-3	SWITCH KE603208-4	SWITCH KE603208-5	PUSH BUTTON KE603208-6	LATCH KE603208-7	CONTACT KE603208-8	CONTACT KE603208-9
# OF POSITIONS	2 maintained	3 maintained	2 spring return from right	3 spring return from both sides	3 spring return from right	flush		normally closed	normally open
ASSEMBLY #									
KE003209-1	1						1		1
KE003209-2	1						1	1	1
KE003209-3		1					1		2
KE003209-4		1					1		1
KE003209-5		1					1		3
KE003209-6			1				1	1	
KE003209-7				1			1		3
KE003209-8				1			1		2
KE003209-9					1		1		2
KE003209-10						1	1	1	1
KE003209-11				1			1		4

# ELECTRICAL COMPONENT ASSEMBLY

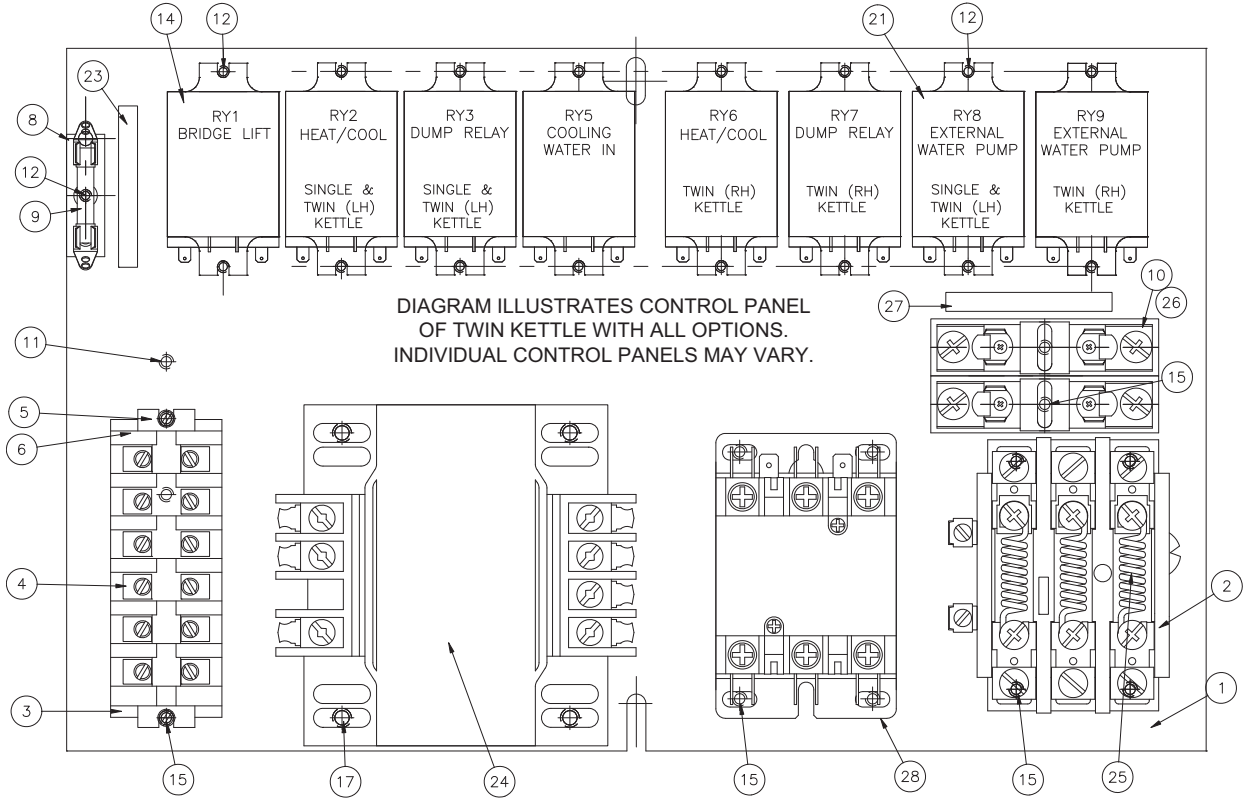

NOTE: ITEMS #40 TO #43 AND #45 ARE NOT SHOWN

KE00888R			
ITEM	PART NUMBER	DESCRIPTION	QTY
1	KE50343-7	COMPONENT MOUNTING PLATE	1
2	KE51982	THERMAL OVERLOAD RELAY	1
3	KE54761-3	TERMINAL BLOCK MOUNTING RAIL	1
4	SK50055-1	TERMINAL BLOCKS	6
5	SK50054-1	TERMINAL BLOCK END BARRIER	1
6	SK50054-2	TERMINAL BLOCK END ANCHOR	1
8	KE51139	FUSE HOLDER	1
10	KE51139-1	FUSE HOLDER	2
11	FA12500	SCREW #8-32 x 3/8 lg. BRASS WITH UNDERCUT FOR GROUND	1
12	FA15018-7	SCREW #6-32 x 1/4 lg.	3
14	KE50753-10	RELAY (RY1)	1
15	FA15018-3	SCREWS #8-32 x 1/4 lg.	12
28	KE603902-1	CONTACTOR	1

HEAT/COOL WITH CONTROL			
<u>MKDL-T</u>			
21	KE50753-10	RELAY	4
12	FA15018-7	SCREW #6-32 x 1/4 LG.	8
<u>TMKDL-T</u>			
21	KE50753-10	RELAY	7
12	FA15018-7	SCREW #6-32 x 1/4 LG.	14
HEAT WITH SSV/DTC/TCR			
<u>MKDL-T</u>			
21	KE50753-10	RELAY	1
12	FA15018-7	SCREW #6-32 x 1/4 LG.	2
<u>TMKDL-T</u>			
21	KE50753-10	RELAY	2
12	FA15018-7	SCREW #6-32 x 1/4 LG.	4
HEAT/COOL WITHOUT CONTROL			
<u>MKDL-T</u>			
21	KE50753-10	RELAY	2
12	FA15018-7	SCREW #6-32 x 1/4 LG.	4
<u>TMKDL-T</u>			
21	KE50753-10	RELAY	4
12	FA15018-7	SCREW #6-32 x 1/4 LG.	8

KE00888-1 MKDL & MKEL COMMON PARTS			
ITEM	PART NUMBER	DESCRIPTION	QTY
9	KE52936-6	FUSE- 3 AMP	1
23	KE95242-2	LABEL	1
30	KE00888R	COMPONENT PLATE ASSEMBLY	1
<u>VOLTAGE OPTIONS</u>			
200-240 V A.C.			
24	KE53838-5	TRANSFORMER (250VA)	1
17	FA15018-4	SCREWS #8-32 x 3/8 lg.	4
25	KE52055	THERMAL OVERLOAD HEATER	3
26	KE52936-16	FUSE, 1.5AMP, SLOW BLOW, TIME DELAY	2
27	KE95242-3	LABEL	1
380-415 V A.C.			
24	KE53838-6	TRANSFORMER	1
17	FA15018-4	SCREWS #8-32 x 3/8 lg.	4
25	KE52055	THERMAL OVERLOAD HEATER	2
26	KE52936-17	FUSE, 3/4AMP, SLOW BLOW, TIME DELAY	2
27	KE95242-4	LABEL	1
440-480 V A.C.; 575-600 V A.C.			
24	KE53838-5	TRANSFORMER	1
17	FA15018-4	SCREWS #8-32 x 3/8 lg.	4
25	KE52055	THERMAL OVERLOAD HEATER	3
26	KE52936-17	FUSE, 3/4AMP, SLOW BLOW, TIME DELAY	2
27	KE95242-4	LABEL	1

KE00888-2 MKGL COMMON PARTS			
ITEM	PART NUMBER	DESCRIPTION	QTY
9	KE52936-5	FUSE- 5 AMP/250V/MDA-5, SLOW BLOW	1
23	KE95242-5	LABEL	1
26	KE52936-14	FUSE- 3 AMP/600V/KLDR 3, SLOW BLOW	2
27	KE95242-6	LABEL	1
30	KE00888R	COMPONENT PLATE ASSEMBLY	1
<u>VOLTAGE OPTIONS</u>			
200-240 V A.C.			
24	KE53838-2	TRANSFORMER (250VA)	1
17	FA15018-4	SCREWS #8-32 x 3/8 lg.	4
25	KE52055	THERMAL OVERLOAD HEATER	3
380-415 V A.C.			
24	KE53838-3	TRANSFORMER	1
17	FA15018-4	SCREWS #8-32 x 3/8 lg.	4
25	KE52055	THERMAL OVERLOAD HEATER	2
440-480 V A.C.; 575-600 V A.C.			
24	KE53838-2	TRANSFORMER	1
17	FA15018-4	SCREWS #8-32 x 3/8 lg.	4
25	KE52055	THERMAL OVERLOAD HEATER	3

# REMOTE CONTROL ASSEMBLY

For units with Water Meter  
and/or DTCl option

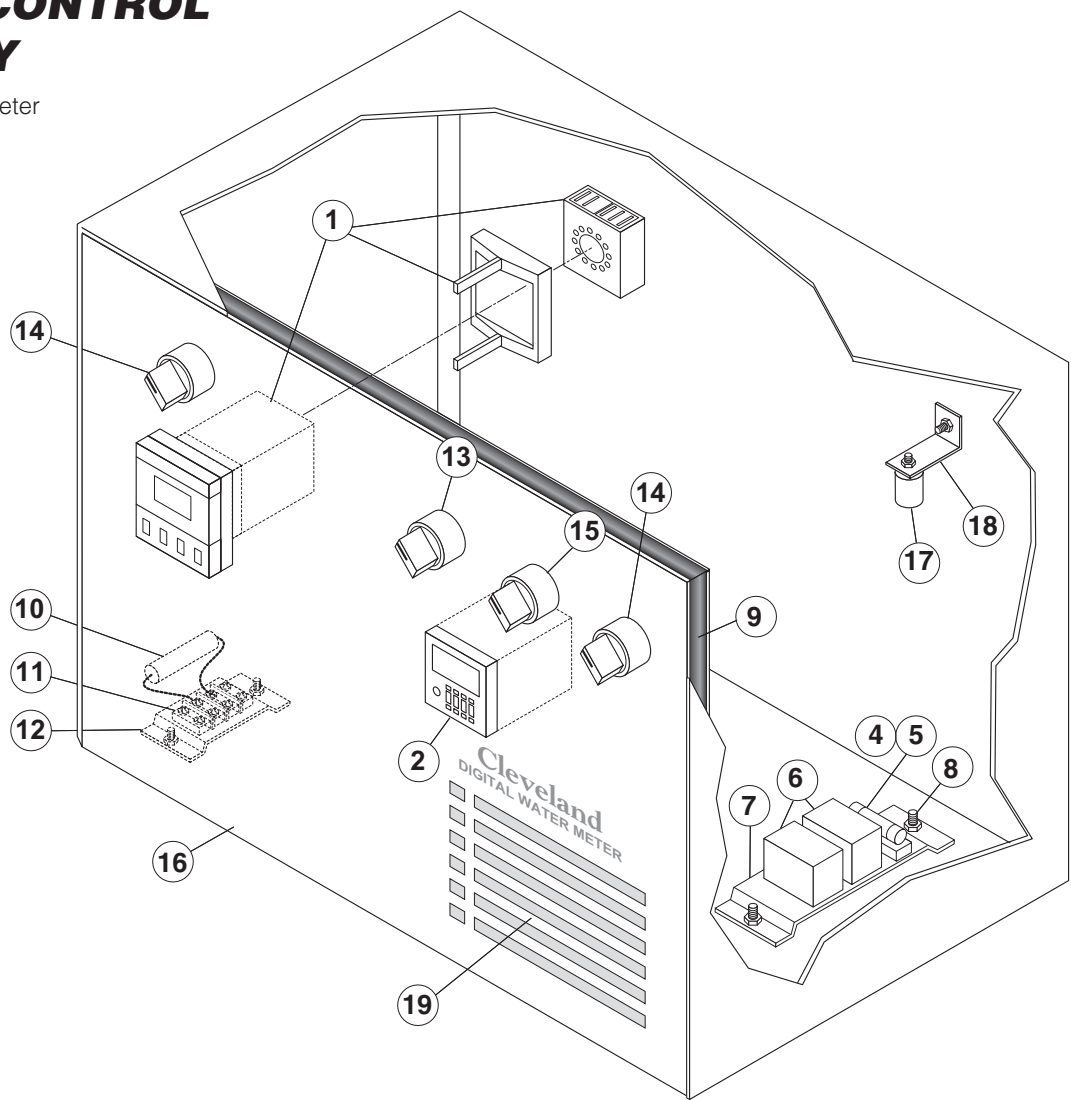

ITEM NO.	PART NO.	DESCRIPTION	QTY.
1.	KE53479-1	Digital Temperature Controller and Indicator	1
2.	KE53257	Digital Counter	1
4.	KE52936-3	Fuse	1
5.	KE51139	Holder, Fuse	1
6.	KE50753-10	Relay	1 (per option)
7.	KE50343-6	Mounting Plate	1
8.	FA10131	Nut	3
9.	KE52280	Weather Strip, 76" long	1
10.	KE01820	Ambient Heater Assembly	1
11.	SK50370-1	Terminal Block, 2 Section	1
	SK50370-2	Terminal Block, 45°	2
	SK50370-3	Terminal Block, 90°	2
12.	KE54402	Mounting Bracket, Terminal Block	1
13.	KE003209-6	Momentary Spring Return Switch Assembly	1
14.	KE003209-1	Switch Assembly, On/Off - Maintained	2
15.	KE003209-7	Momentary Spring Return Switch Assembly	1
16.	KE52272	Console Door	1
17.	KE52710	Thermostat	1
18.	KE603924	Bracket for Thermostat	1
19.	KE95229	Label	1

# ELECTRIC KETTLE COMPONENT PLATE

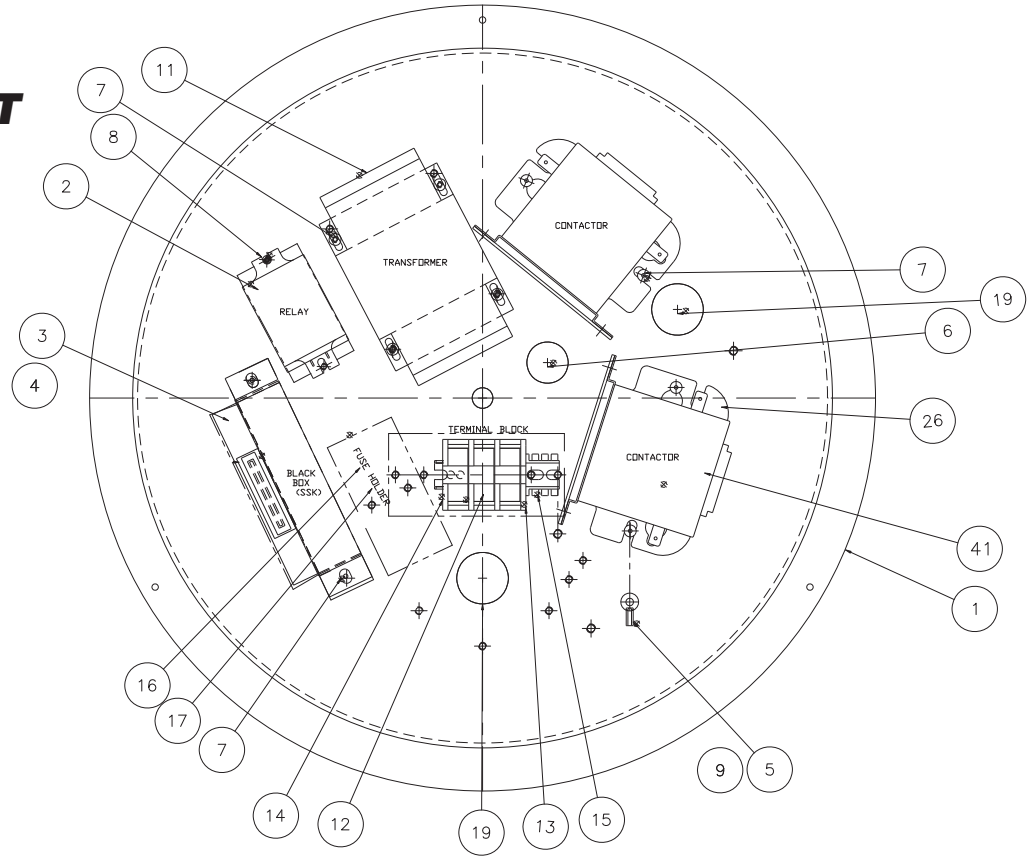

ITEM NO.	PART NO.	DESCRIPTION	QTY.
1.	KE50343-29	COMPONENT PLATE, 25 gallon	1
	KE50343-9	COMPONENT PLATE, 30 gallon and up	1
2.	KE50753-7	RELAY	1
3.	KE00458-1	KETTLE CONTROL BOX	1
4.	KE50303-2	ELECTRONIC BOX HOLDER	1
5.	KE50473	GROUND LUG	2
6.	KE54833-3	SNAP-IN BUSHING, 0.875" DIA.	1
7.	FA15018-4	8-32 X 3/8	16
8.	FA15018-7	8-32 X 1/4	2
9.	FA11525-1	10-32 X 3/8	1
11.		<b>TRANSFORMERS</b>	
	KE53838-11	40-100 gallon, 380-415V	6
	KE53838-12	40-100 gallon, 440-480V	6
12.		<b>TERMINAL BLOCKS</b>	
	KE50377	40-100 gallon, 200-240V, high wattage (6 elements)	6
	SK50055-1	ALL OTHERS	6
13.		<b>TERMINAL BLOCK ENDS</b>	
	KE50376	40-100 gallon, 200-240V, high wattage (6 elements)	2
	SK50054-1	ALL OTHERS	2
14.	SK50054-2	ANCHOR, TERMINAL BLOCK	1
15.	KE54761	RAIL, TERMINAL BLOCK	1
16.	KE51139-1	FUSE HODLER, 380-480V	1
17.	KE52936-1	FUSE, 380-480V	1
19.	KE54833-4	SNAP-IN BUSHING, 1.0" DIA.	2
26.	KE603987	CONTACTORS MOUNTING BRACKET	2
41.		<b>CONTACTORS</b>	
	KE603902-4	40 gallon, 200-240V, high wattage (6 elements)	1
	KE603902-5	60-100 gallon, 200-240V, high wattage (6 elements)	1
	KE603902-3	ALL OTHERS	1

# MAIN CONSOLE CONTROLS

For standard Mixer Kettles

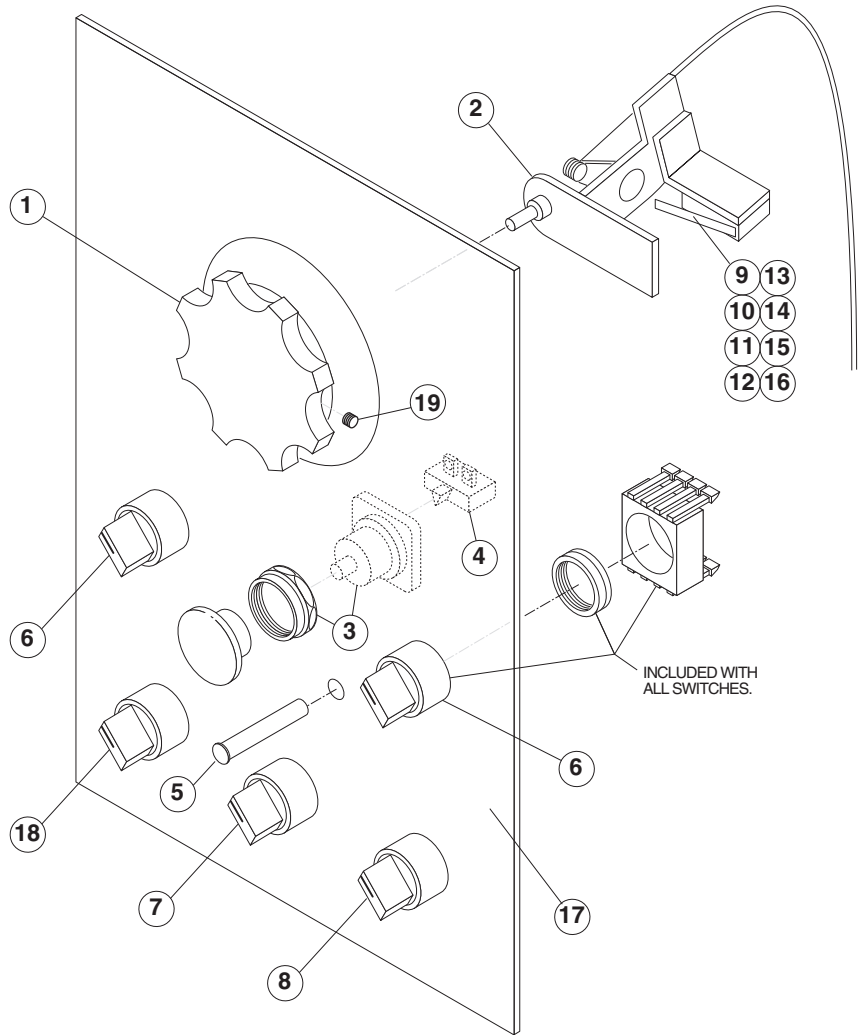

ITEM NO.	PART NO.	DESCRIPTION	QTY.
1.	KE52190	Knob, Speed Control	1
2.	KE00860	Cable and Bracket, Speed Control (includes Micro Switch, item 9)	1
3.	KE53193	Emergency Switch	1
4.	KE53377	Push Button Contact Block	1
5.	SK50315-1	Pilot Light	1
6.	KE003209-3	Switch Assembly, On/Off/On - Maintained	
6.	KE003209-4	Switch Assembly, On/Off - Maintained (single kettle)	1
		(twin kettle)	2
7.	KE003209-5	Switch Assembly, On/Off/ON - Maintained	1
8.	KE003209-11	Switch Assembly, On/Off/On - Momentary	1
9.	KE52180	Micro Switch	1
10.	FA10032	Machine Screw, #4-40 x 5/8" LG	2
12.	FA32002	Tooth Lock Washer #4	2
13.	FA20000	Hex Nut, #4-40	2
14.	KE52050	Cable Clamp	2
15.	FA11054	Screw, 8-32	2
16.	FA21004	Washer	2
17.	KE95230	Label:	1
18.	KE003209-1	Switch Assembly, On/Off	1
19.	KE52364	Plunger, Set Screw	1

# WATER METER ASSEMBLY - 18" CONSOLE

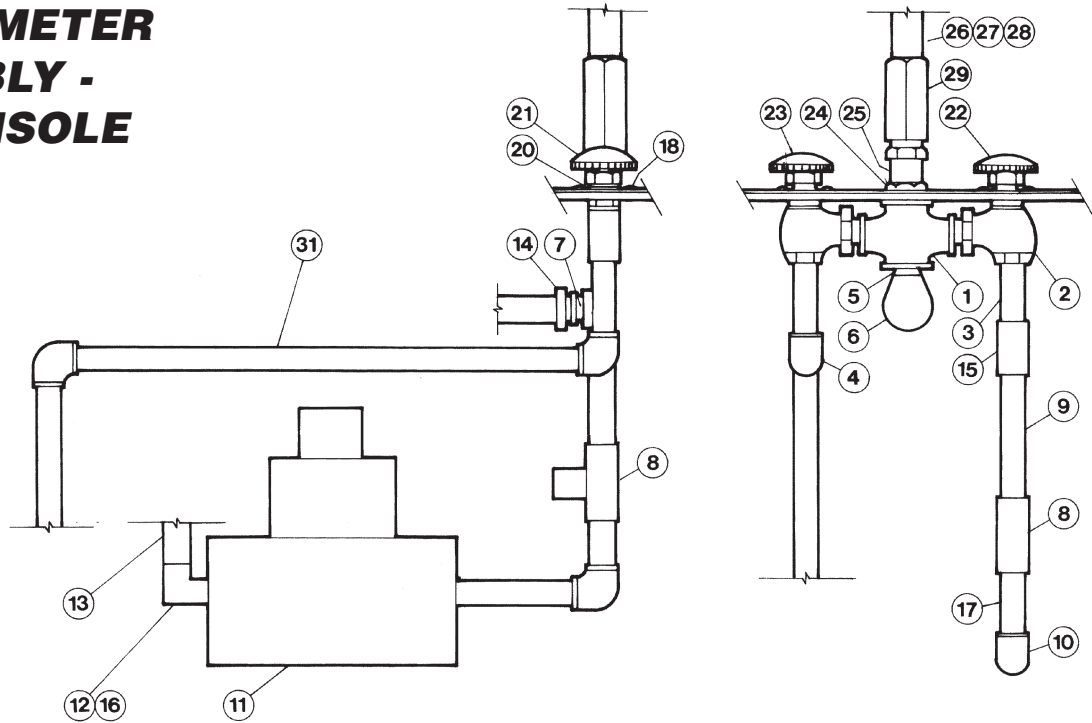

ITEM NO.	PART NO.	DESCRIPTION	QTY.
1.	FI05058	3/4" Cross	.1
2.	KE02055-2	Steam Valve Modification	.2
3.	N0640B4-5	Nipple	.2
4.	FI00063	Elbow 90 degree	.4
5.	FI00356	Reducing Bushing	.1
6.	KE600812-1	Street Elbow	.1
7.	FI05029	Hose Barb	.2
8.	KE54834-5 SE50407 SE50401	* Solenoid Valve, 3/4" Rebuild Kit Replacement Coil	.1
9.	N0640B3 N0640B3-5	Nipple, Gallon Meter Nipple, Litre Meter	.1
10.	FI00363-3	Reducing Elbow 90 Degree	.1
11.	KE51861 KE51860	Gallon Meter Litre Meter	.1
12.	FI00062	Elbow 90 Degree	.1
13.	KE52173	1/2"1.D. Hot Water Wash-up Hose	.1
14.	FI05220-3	Hose Clamp	.2
15.	FI00179	Tee	.1
16.	FI05074 KE600362	Nipple Nipple for Water Cooling Only	.2
17.	N0640B1-5	Nipple	.1
18.	FA11091	Machine Screw	.8
20.	KE51369	Steam Valve Flange	.2
21.	SE00028	Knob Assembly	.2
22.	KE603823	Label "Hot"	.1
23.	KE603824	Label "Cold"	.1
24.	SD50097	Flanged Nut	.1
25.	KE51585	Faucet Spout Fitting	.1
26.	KE50825-7	Faucet Spout	.1
27.	FA05002-19	"O" Ring	.1
28.	FA950707-10	Retaining Ring Carter	.1
29.	KE51736	Long Faucet Nut	.1

**\*NOTE:** See SOLENOID VALVE MAINTENANCE section for further information.

# MANUAL & POWER TILT, ELECTRIC AND DIRECT STEAM - 10" CONSOLE

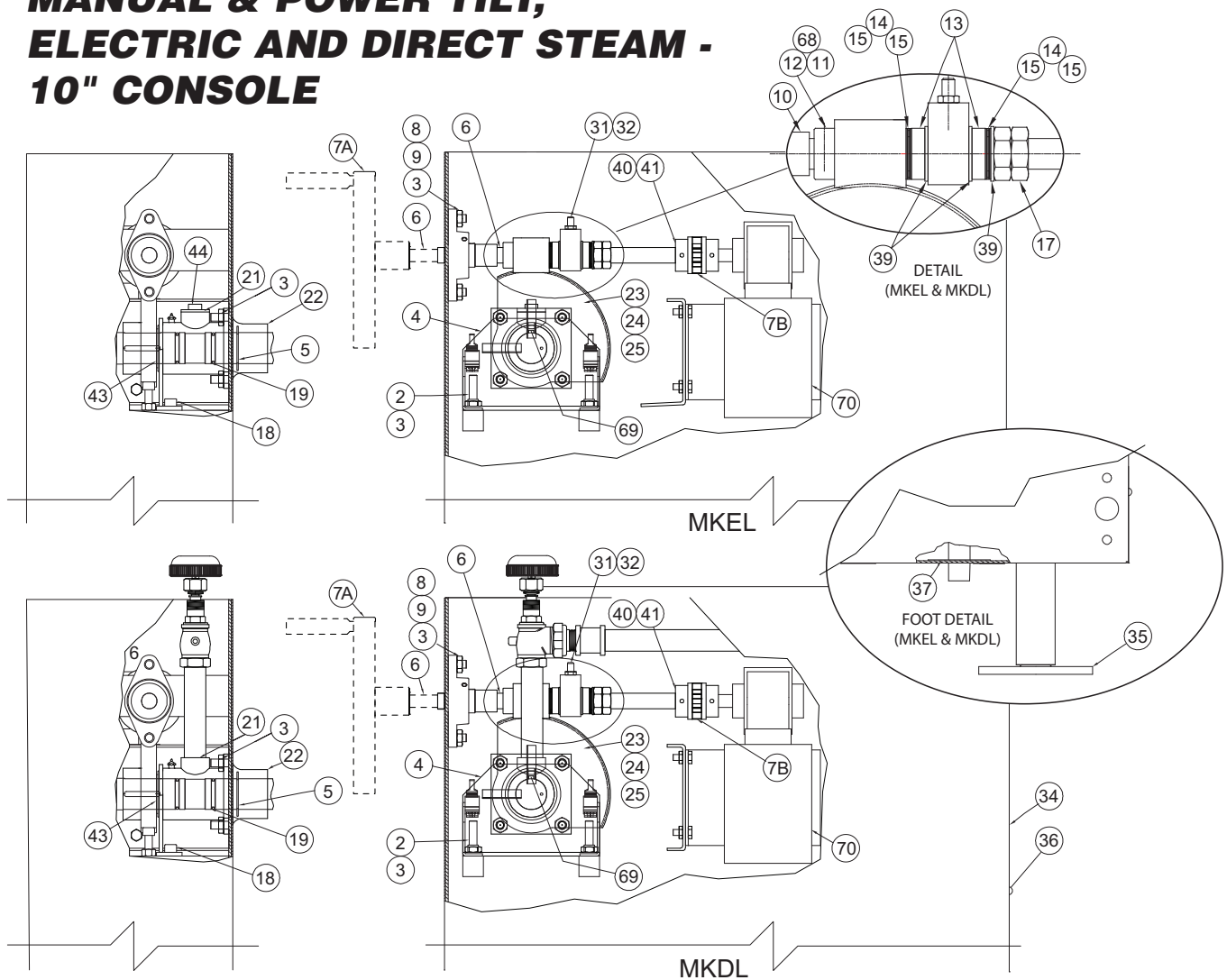

ITEM	PART #	DESCRIPTION	QTY
COMMON PARTS			
2	FA10772	HEX SOCKET CAP SCREW 3/8-16 X 1 1/2"	2
3	FA20030	HEX NUT; # 3/8-16 ZINC PLAT	8
8	KE51730	BEARING; TILT SHAFT	1
9	FA31010	SPLIT LOCKWASHER; 3/8" BOLT	6
12	FA95005	TENSION PIN; 3/16"D. X1-1/4 LONG	1
13	KE52193-1	SPACER; THRUST BEARING(MKDL)	2
14	KE52191	BEARING; NTA1220 INA #TC1220	2
15	KE52192	WASHER; BEARING INA #TWA1220	4
17	FA95008	JAM NUT; 3/4-16 MS.	2
18	FA10768	HEX SOCKET CAP SCREW 3/8-16 X 3/4"	2
25	FA19201	SET SCREW; 3/8-24 X 1/2"	1
31	FA19177	SET SCREW; 5/16-24 X 1"	1
32	FA20047	JAM NUT; 5/16-24 PLATED	1
34	FA11145	SCREW; 10-32 X 3/8" 18-8SS	8
39	FA30088	WASHER; 3/4 SAE	3
70	FA30088	MOTOR	1

\* - ITEMS USED IN MKDL/TMKDL ONLY.

ITEM	PART #	DESCRIPTION	QTY
4	KE00691	TRUNNION HOUSING SUPPORT	1
	KE01209	TRUNNION HOUSING SUPPORT	1
5	FA95007-1	RET.RING; SP-NR #R3100-150, 40-80 GAL	2
	FA95007-4	RET.RING; SP-NR #R3100-200, 100-150 GAL	2
6	KE50375	MAN.TILT SHAFT; SMALL GEAR	1
	KE503751	MAN.TILT SHAFT; BIG GEAR	1
	KE50441-1	POWER TILT SHAFT; MKDL/TMKDL-40/60/80-T; MKEL/TMKEL-40/60-T	1
	KE52836-1	POWER TILT SHAFT; MKDL/TMKDL-150-T	1
	KE52836-3	POWER TILT SHAFT; MKDL/TMKDL-100/125-T; MKEL/TMKEL-80/100-T	1

ITEM	PART #	DESCRIPTION	QTY
7A	KE00508	HANDWHEEL ASS'Y.; KETTLES	1
7B	TKIT099	POWER TILT KIT; MKDL/TMKDL-40/60/80-T; MKEL/TMKEL-40/60-T	1
	TKIT099-1	POWER TILT KIT; MKDL/TMKDL-100/125/150-T; MKEL/TMKEL-80/100-T	1
10	KE50426-6	SPACER; SHAFT TILT KETTLES 25-80 GAL	1
	KE50426-7	SPACER; SHAFT TILT KETTLES 100-150 GAL	1
11	KE50315	WORM GEAR; KETTLES, 40-125 GAL	1
	KE503151	WORM GEAR; MKDL 150 & UP	1
19	FA05002-6	O'RING; VITON (A-218), 40-80 GAL	2
	FA05002-27	O'RING; VITON (A-224), 100-150 GAL	2
21	KE00699-1	TRUNNION HSG.WLD'T/MACH	1
	KE01182-1	TRUNNION HSG.ASS'Y.; 2"	1
22	KE51629-1	TRUNNION SLEEVE; 2" PIPE	1
	KE51629-3	TRUNNION SLEEVE; 3" TUBE	1
23	KE00151	SEGMENT GEAR; SMALL(1.5")	1
	KE52833	SEGMENT GEAR; LARGE(2")	1
24	FA95055-4	KEY; SQUARE, 1/4 X 1 1/2	1
	FA95055-11	KEY; SQUARE 3/8 X 2	1
35	KE00099	FOOT ASS'Y.	2/3
36	KE51628-1	CONSOLE REAR COVER; 10" CONSOLE	1
	KE51628-2	REAR COVER; 12" CONSOLE	1
37	KE51998	WASHER; STEAM-IN	2
38	KE519981	WASHER; STEAM-IN (100 UP)	2
43	KE527041	WASHER; BRASS (2 1/64 ID)	2
	FI05193	PLASTIC PLUG 3/4 NPT	1
44	FI05194	BLACK PLUG 1 1/4 NPT	1
68	KE53293	WORM COLLAR; 150 GAL & UP	1
69	FA95003	KEY; WOODRUFF #606	1
70	KE528321	MOTOR	1

# COMPONENT PLATE ASSEMBLY - POWER TILT KETTLES

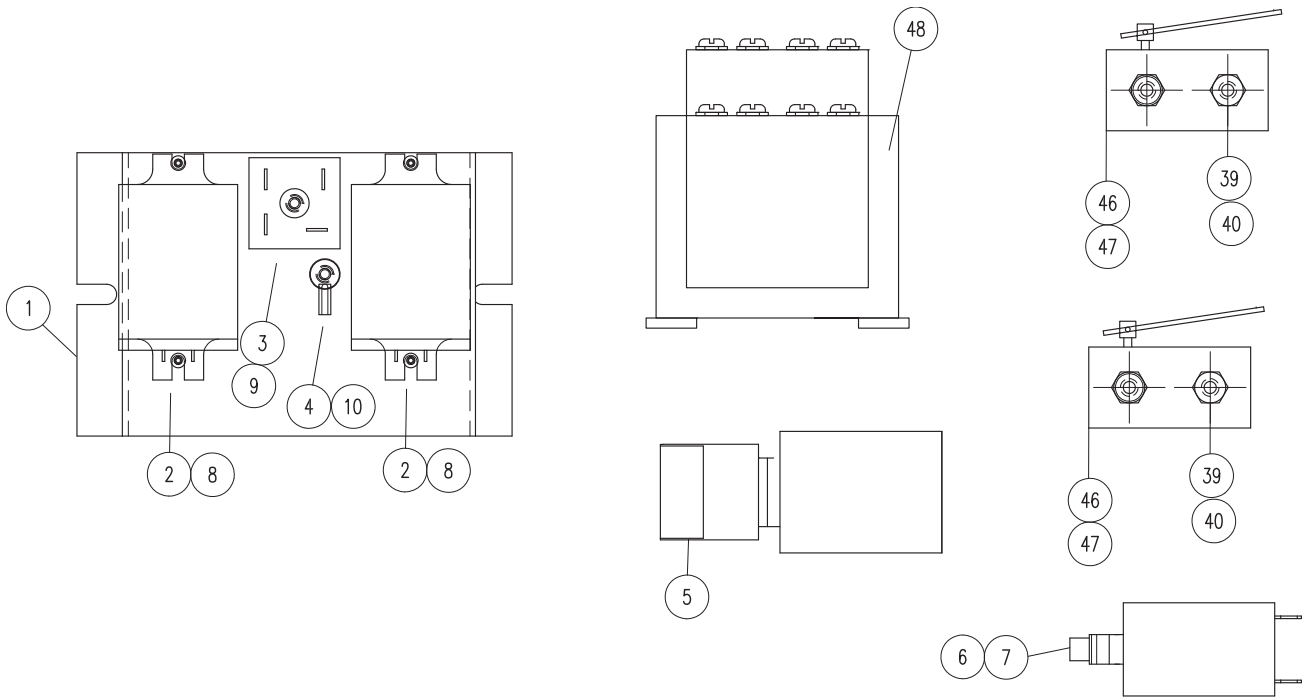

VOLTS OPTION	PART NUMBER	COMMON PARTS COMPONENT PLATE ASS'Y		TRANSFORMER ITEM # 48	
		PART #	QTY.	PART #	QTY.
208V	KE02185-11	KE02185-5	1	KE53838-10	1
220V-480V	KE02185-12	KE02185-5	1	KE53838-12	1
380V	KE02185-13	KE02185-5	1	KE53838-11	1

COMMON PARTS KE02185-5			
1	KE50343-16	COMPONENT PLATE	1
2	KE50753-10	RELAY, 10 A/120V	2
3	KE50581	BRIDGE RECTIFIER	1
4	KE50473	GROUND LUG	1
5	KE003209-11	SWITCH, POWER TILT	1
6	KE50579-1	CIRCUIT BREAKER, 1.5A	1
7	KE50580	WATER RESISTANT BOOT	1
8	FA11051	6-32 X 3/16 PAN PHIL S.S.	4
9	FA11091	8-32 X 3/8 PAN PHIL S.S.	1
10	FA11089	8-32 X 1/4 PAN PHIL S.S.	1
39	FA20002	HEX NUT 6-32	2
40	FA11060	SCREW 6-32 X 1	2
46	KE51007	MICRO SWITCH, HONEYWELL	2
47	KE50498	MICRO SWITCH INSULATION	2
48	REF.KE53838	SEE ABOVE	1

# TANGENT DRAW-OFF VALVES

## 1.5" & 3" TANGENT DRAW-OFF VALVE

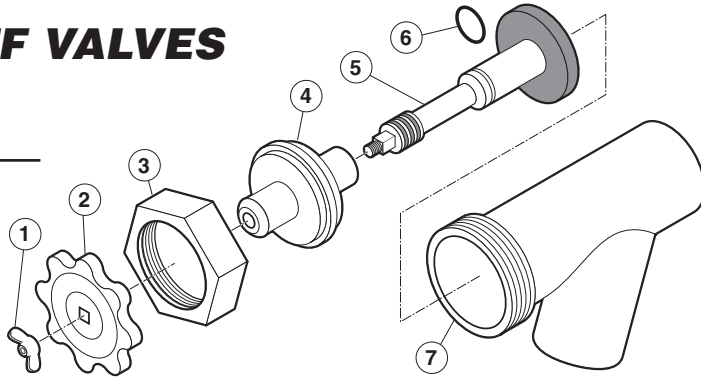

ITEM NO.	PART NO.	DESCRIPTION	QTY.
1. - 7.	KE50219	1.5" DRAW-OFF ASSEMBLY	1
	KE50973	3" DRAW-OFF ASSEMBLY	1
1.	SE50019	WING NUT, TD-1.5	1
	FA21501-1	ACCORN NUT, TD-3	1
	FA11511-1	SCREW (CORRECTIONAL PACKAGE)	1
	FA30505-1	WASHER (CORRECTIONAL PACKAGE)	1
2.	SE50017	KNOB, TD-1.5	1
	SE50018	KNOB, TD-3	1
3.	FI05180-3	HEX NUT, TD-1.5	1
	FI05180-2	HEX NUT, TD-3	1
4.	SE50011	RETAINER, TD-1.5	1
	SE50013	RETAINER, TD-3	1
5.	SE50008	PISTON, TD-1.5	1
	SE50010-1	PISTON, TD-3	1
	KE53290-4	PISTON, TD-3, MODIFIED (CORRECTIONAL PACKAGE)	1
6.	FA05002-24	"O" RING, TD-1.5	1
	FA05002-38	"O" RING, TD-3	1
7.	SE50005	VALVE BODY, TD-1.5	1
	KE50973	VALVE BODY, TD-3	1

## 2" TANGENT DRAW-OFF VALVE

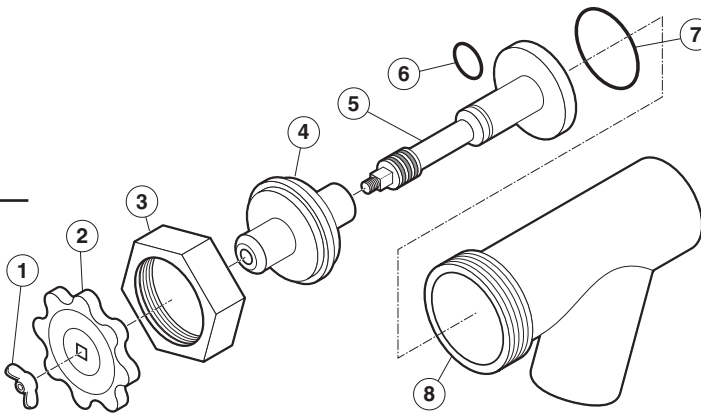

ITEM NO.	PART NO.	DESCRIPTION	QTY.
1. - 7.	KE50972-B	2" DRAW-OFF ASSEMBLY	1
1.	FA95049	WING NUT, TD-2	1
	FA511511-5	SCREW, TD-2 (CORRECTIONAL PACKAGE)	1
2.	KE52755	KNOB, TD-2	1
3.	FI05180-1	HEX NUT, TD-2	1
4.	KE52753	RETAINER, TD-2	1
5.	KE52752-1	PISTON, TD-2	1
	KE53290-3	PISTON, TD-2 (CORRECTIONAL PACKAGE)	1
6.	FA05002-24	"O" RING, BUNA-N (A-111), TD-2	1
7.	FA05002-55	"O" RING, VITON (AS568A-322), TD-2	1
8.	KE52751	VALVE BODY, TD-2	1

# BUTTERFLY VALVE, 3"

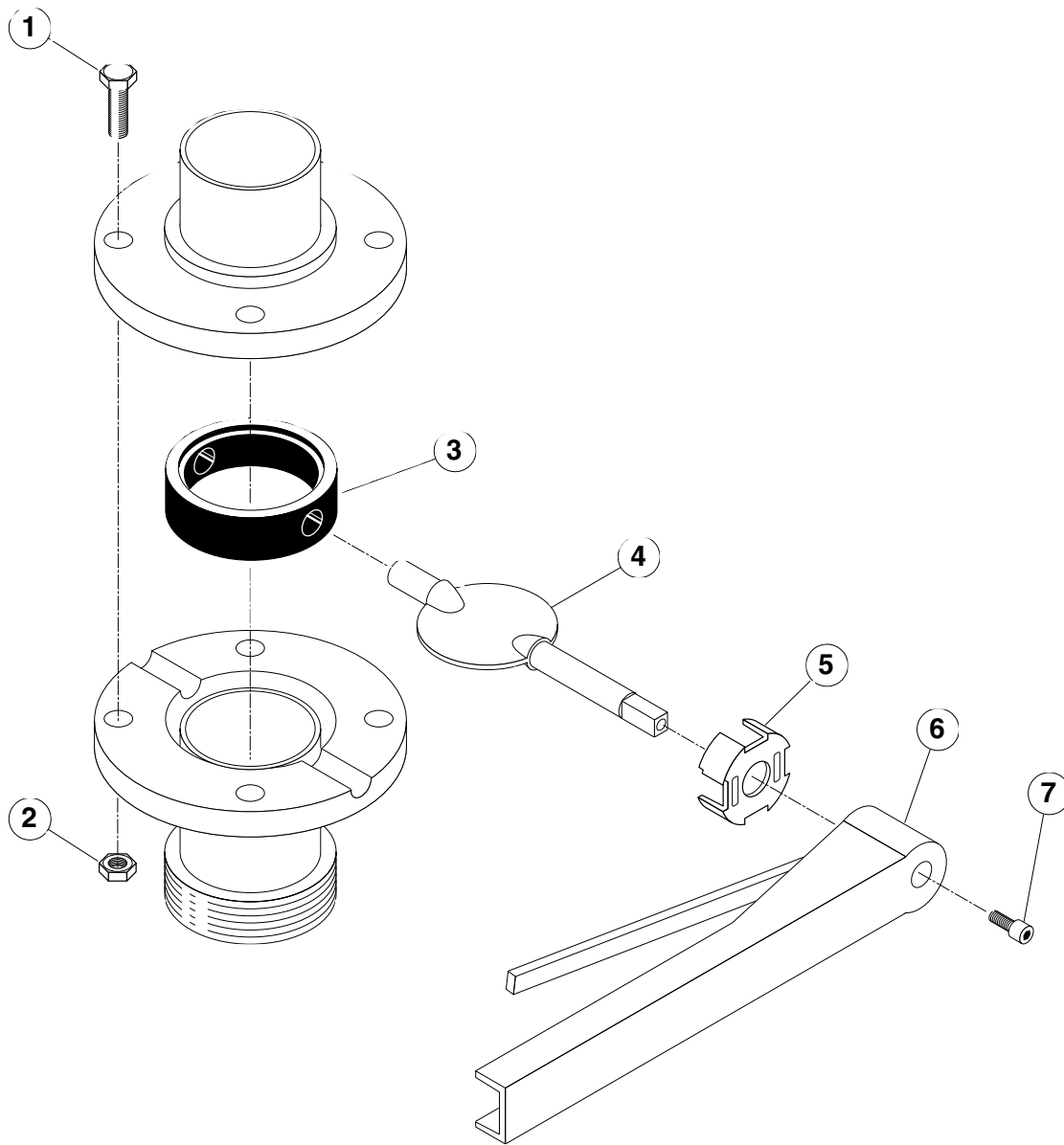

ITEM NO.	PART NO.	DESCRIPTION	QTY.
1. - 7.	KE52286	Butterfly Valve (includes housing)	1
1.	FA11224	Bolt, 5/16-18x1" S.S.	6
2.	FA21024	Nut, 5/16-18	6
3.	SE50433-1	Seat	1
4.	SE50434-1	Stem	1
5.	SE50435-1	Locking Spider	1
6.	SE50436	Handle Assembly	1
7.	SE50437	Allen Bolt	1

# AIR VALVE ASSEMBLY FOR FPVA-3

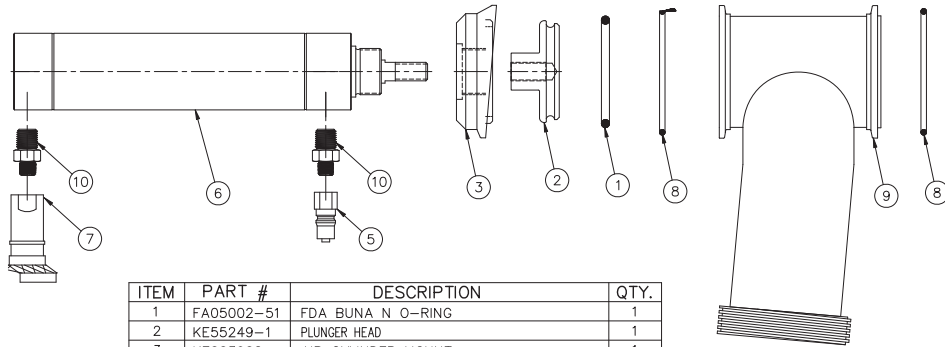

ITEM	PART #	DESCRIPTION	QTY.
1	FA05002-51	FDA BUNA N O-RING	1
2	KE55249-1	PLUNGER HEAD	1
3	KE603962	AIR CYLINDER MOUNT	1
5	KE55257	1/8 NPT BRASS QUICK DISCONNECT COUPLING (MALE HALF)	1
6	KE55253-1	AIR OPERATED CYLINDER	1
7	KE55262	1/8 NPT BRASS QUICK DISCONNECT COUPLING (FEMALE HALF)	1
8	FA05002-53	FDA BUNA N O-RING	2
9	KE003700	DISCHARGE TEE ASSEMBLY	1
10	KE55251-1	HEX NIPPLE(1/4 NPT TO 1/8 NPT)	2

KE02291-1

# AIR SOLENOID ASSEMBLY FOR FPVA-3

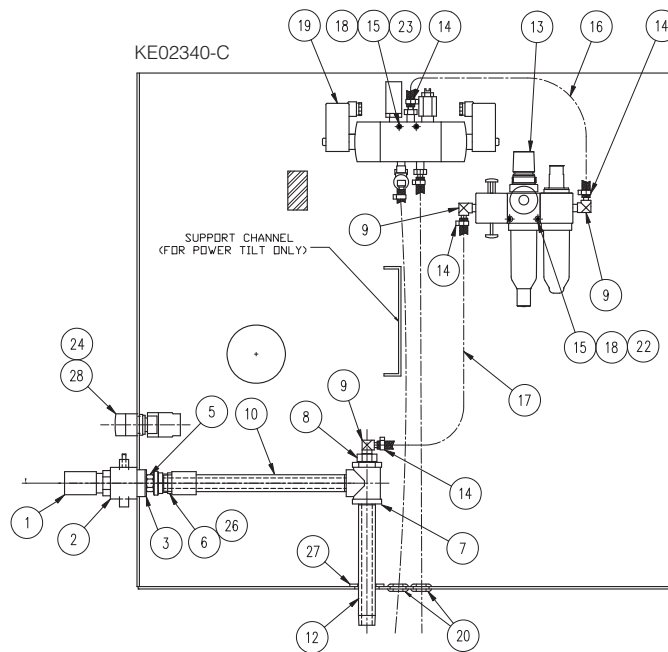

BILL OF MATERIALS (COMMON PARTS)			
ITEM	PART #	DESCRIPTION	QTY
1	KE601603	QUICK CONNECT	1
2	KE601601	SLIDE VALVE	1
3	FA30512	SPACER WASHER	1
4	FA32500	TOOTH LOCK WASHER 7/8 DIA.	1
5	KE52697	NUT 1/2 NPS BRASS	1
6	KE601602	AIR FITTING	1
7	KE600814-1	TEE 1/2 NPT (FIP x FIP x FIP)	1
8	FI00351	BUSHING 1/2 MIP x 1/4 FIP	1
9	FI05318	HOSE BARB 90° ELBOW	3
10	CONSULT FACTORY		
12	CONSULT FACTORY		
13	KE02369	FILTER-REGULATOR ASSEMBLY	1
14	FI05220-1	GEAR CLAMP	4
15	FA21002	#6-32 HEX NUT SS	4
16	KE532176	PNEUMATIC HOSE (1/4 I.D.x12 1/2 LG.)	1
17	KE532177	PNEUMATIC HOSE, (1/4 I.D.x31 LG.)	1
18	FA32004	TOOTH LOCK WASHER, #6 ZINC PLATED	4
19	KE02292	AIR SOLENOID ASSY	1
20	KE50555-3	GROMMET	2
22	KE55307-2	MODIFIED SCREW, #6-32 x 1-3/4 LG.	2
23	KE55307-1	MODIFIED SCREW, #6-32 x 1-1/4 LG.	2
24	KE95481-5	LABEL, PRODUCT DISCHARGE VALVE	1
25	KE55232	WIRING DIAGRAM FOR AIR VALVE	1
26	FI00266	COUPLING, 1/2 BRASS	1
27	KE54353	WASHER FOR DRAIN HOLE	1
28	KE003209-9	SWITCH; ON/OFF/ON	1

## SPARE PARTS LIST

PART NO.	DESCRIPTION	QTY.
KE51834	SCRAPER BLADES	5
KE00860	SPEED CONTROL CABLE ASSEMBLY	1
KE52936-6	FUSE, 3 AMP	2
KE50753-10	RELAY	2-5
KE52936-16	FUSE	2
KE603208-9	CONTACT BLOCK, NORMALLY OPEN	2
KE603208-8	CONTACT BLOCK, NORMALLY CLOSED	2



Every new piece of Welbilt Foodservice equipment comes with KitchenCare® and you choose the level of service that meets your operational needs from one restaurant to multiple locations

**StarCare** – Warranty & lifetime service, certified OEM parts, global parts inventory, performance audited

**ExtraCare** — CareCode, 24/7 Support, online/mobile product information

**LifeCare** – Install & equipment orientation, planned maintenance, KitchenConnect™, MenuConnect®

**Talk with KitchenCare®** • 1-844-724-CARE • [www.mtwkitchencare.com](http://www.mtwkitchencare.com)



To learn how Welbilt Foodservice and its leading brands can equip you, visit our global web site at [www.welbilt.com](http://www.welbilt.com), then discover the regional or local resources available to you.