



Visit www.clevelandrange.com to locate a service or sales representative in your area.



Direct Steam Table Top Mixer Kettles

Installation, Operation, Maintenance, Parts & Service

This manual is updated as new information and models are released. Visit our website for the latest manual.

MODELS:

MKDT-12-T
MKDT-20-T

For your future reference.

Model # _____

Serial # _____

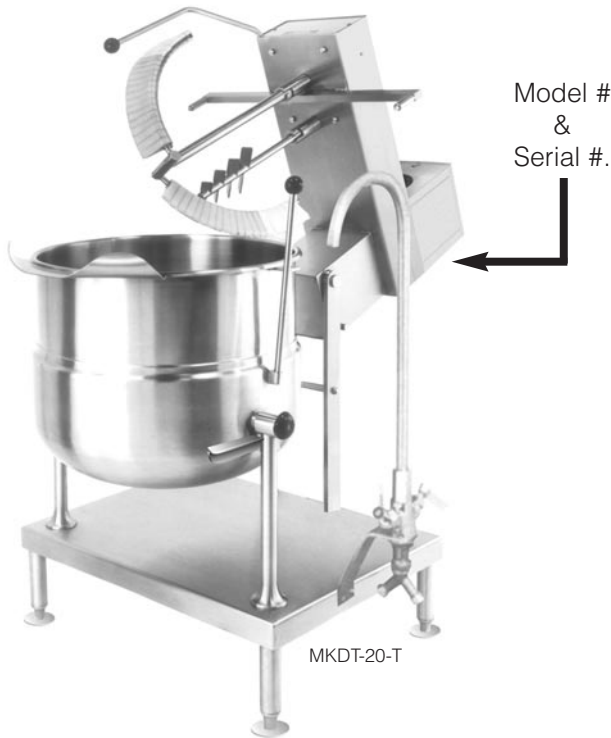

Read the manual thoroughly.
Improper installation, operation or maintenance can cause property damage, injury or death.

TABLE OF CONTENTS

Statement of Responsibilities	1
For your safety	2
Installation	4
Operating Instructions	6
Cleaning Instructions	7
Preventative Maintenance	9
Trouble Shooting & Maintenance	10
Service Parts	13



STATEMENT OF RESPONSIBILITIES / DÉCLARATION DES RESPONSABILITÉS / DECLARACIÓN DE RESPONSABILIDADES

This document is for use by experienced and trained Qualified Cleveland Range, LLC Authorized Service Representatives who are familiar with both the safety procedures, and equipment they service. Cleveland Range, LLC assumes no liability for any death, injury, equipment damage, or property damage resulting from use of, improper use of, or failure to use the information contained in this document. Cleveland Range, LLC has made every effort to provide accurate information in this document, but cannot guarantee that this document does not contain unintentional errors and omissions.

The information in this document may be subject to technical and technological changes, revisions, or updates. Cleveland Range, LLC assumes no liability or responsibility regarding errata, changes, revisions, or updates.

Qualified Cleveland Range, LLC Authorized Service Representatives are obligated to follow industry standard safety procedures, including, but not limited to, OSHA regulations, and disconnect / lock out / tag out procedures for all utilities including steam, and disconnect / lock out / tag out procedures for gas, electric, and steam powered equipment and / or appliances.

All utilities (gas, electric, water and steam) should be turned OFF to the equipment and locked out of operation according to OSHA approved practices during any servicing of Cleveland Range equipment

Qualified Cleveland Range, LLC Authorized Service Representatives are obligated to maintain up-to-date knowledge, skills, materials and equipment.

Ce document est destiné à l'usage des Représentants de Service qualifiés et autorisés de Cleveland Range, LLC qui possèdent l'expérience et la formation ainsi que la bonne connaissance des mesures de sécurité et du matériel qu'ils entretiennent.

Cleveland Range, LLC décline toute responsabilité pour tout cas de décès, blessure, dommage matériel ou dommage aux biens résultant de l'utilisation, de la mauvaise utilisation ou du manquement d'utilisation des renseignements contenus dans ce document.

Cleveland Range, LLC s'est efforcé à fournir des renseignements précis dans ce document mais ne peut garantir que ce document soit exempt d'erreurs et d'omissions non intentionnelles.

Les renseignements contenus dans ce document peuvent être assujettis à des changements techniques et technologiques, des révisions ou des mises à jour.

Cleveland Range, LLC décline toute obligation ou responsabilité concernant les errata, modifications, révisions ou mises à jour.

Les Représentants de Service qualifiés et autorisés de Cleveland Range, LLC sont tenus de se conformer aux mesures de sécurité normalisées de l'industrie, y compris, mais sans s'y limiter, les réglementations de l'OSHA, les procédures de débranchement / verrouillage / étiquetage relatives à tous les services publics, dont l'approvisionnement en vapeur, et les procédures de débranchement / verrouillage / étiquetage relatives aux équipements et/ou appareils fonctionnant au gaz, à l'électricité et à la vapeur.

Au cours de tout entretien d'un appareil Cleveland Range, tous les services publics (gaz, électricité, eau et vapeur) doivent être FERMÉS au niveau de l'appareil et le dispositif de fonctionnement doit être verrouillé suivant les pratiques approuvées de l'OSHA.

Les Représentants de Service qualifiés et autorisés de Cleveland Range, LLC sont tenus d'actualiser en permanence leurs connaissances, compétences, matériel et équipement.

Este documento está destinado para el uso de los Representantes de Servicio calificados y autorizados de Cleveland Range, LLC quienes cuentan con la experiencia y la capacitación así como el buen conocimiento de las medidas de seguridad y de los equipos que mantienen.

Cleveland Range, LLC, declina toda responsabilidad en caso de cualquier fallecimiento, lesiones, daños al equipo o daños a la propiedad resultantes de la utilización, del uso indebido o de la falta de utilización de la información provista en este documento.

Cleveland Range, LLC se ha esforzado en suministrar información precisa en este documento, pero no puede garantizar que este documento esté exento de errores y de omisiones no intencionales.

La información contenida en este documento podría estar sujeta a cambios técnicos o tecnológicos, revisiones o actualizaciones. Cleveland Range, LLC declina toda obligación o responsabilidad con respecto a erratas, modificaciones, revisiones o actualizaciones.

Los Representantes de Servicio calificados y autorizados de Cleveland Range, LLC tienen la obligación de seguir los procedimientos estándar de seguridad de la industria; los cuales incluyen pero no se limitan a los reglamentos de la OSHA (La Administración de la Seguridad y Salud Ocupacionales), los procedimientos de desconexión, cierre y etiquetado relativos a todos los servicios públicos incluyendo el suministro de vapor y los procedimientos de desconexión, cierre y etiquetado para los equipos y/o aparatos que funcionan a base de gas, electricidad o vapor.

Cuando se esté dando servicio o mantenimiento a un aparato de Cleveland Range, todos los servicios públicos (gas, electricidad, agua y vapor) deben estar APAGADOS para el equipo en cuestión y se debe seguir el procedimiento de cierre de operaciones de acuerdo con las prácticas aprobadas por la OSHA.

Los Representantes de Servicio calificados y autorizados de Cleveland Range, LLC tienen la obligación de actualizar constantemente sus conocimientos, destrezas, materiales y equipamiento.

FOR YOUR SAFETY / POUR VOTRE SÉCURITÉ / PARA SU SEGURIDAD

FOR YOUR SAFETY

Do not store or use gasoline or any other flammable liquids and vapours in the vicinity of this or any other appliance.

POUR VOTRE SÉCURITÉ

Ne pas entreposer ou utiliser d'essence ou d'autres liquides ou vapeurs inflammables à proximité de cet appareil ou de tout autre appareil.

PARA SU SEGURIDAD

No guarde ni use gasolina o cualesquiera otros líquidos o vapores inflamables en las cercanías de éste o cualquier otro aparato.

WARNING: Improper installation, operation, adjustment, alteration, service or maintenance can cause property damage, injury or death. Read the installation and operating instructions thoroughly before installing, operating or servicing this equipment.

AVERTISSEMENT : Toute mauvaise pratique en matière d'installation, de fonctionnement, de réglage, de modification, d'entretien ou de maintenance peut causer des dommages matériels, des blessures ou la mort. Lisez la totalité des instructions d'installation et d'utilisation avant d'installer, d'utiliser ou d'entretenir cet équipement.

ADVERTENCIA: La indebida instalación, operación, ajuste, modificación, servicio o mantenimiento puede ocasionar daños a la propiedad, lesiones o muerte. Lea detenidamente las instrucciones de instalación y de operación antes de instalar, poner a funcionar o dar servicio a este equipo.

Do not spray aerosols in the vicinity of this appliance while it is in operation.

This appliance is not to be used by persons with reduced physical, sensory or mental capabilities, or lack of experience and knowledge, unless they have been given supervision or instruction concerning use of the appliance by a person responsible for their safety.

This appliance is not for use by children and they must be supervised not to play with it.

Retain this manual for your reference.

Ne pas pulvériser des aérosols dans le voisinage de cet appareil alors qu'il est en fonctionnement.

Cet appareil ne doit pas être utilisé par des personnes dont les capacités physiques, sensorielles ou mentales sont réduites, ou des personnes dénuées d'expérience ou de connaissance, sauf si elles ont pu bénéficier, par l'intermédiaire d'une personne responsable de leur sécurité, d'une surveillance ou d'instructions préalables concernant l'utilisation de l'appareil.

Cet appareil n'est pas destiné à être utilisé par des enfants et ils doivent être surveillés pour s'assurer qu'ils ne jouent pas avec l'appareil.

Conservez ce manuel pour votre référence.

No pulverice aerosoles en las proximidades de este aparato mientras está en funcionamiento.

Este aparato no debe ser utilizado por personas con capacidades físicas, sensoriales o mentales reducidas, o que no tengan la experiencia y los conocimientos adecuados, a menos que estas personas hayan recibido supervisión e instrucciones en cuanto al uso del aparato por la persona responsable de la seguridad de ellas.

Guarde este manual para su referencia.



WARNING / AVERTISSEMENT / ADVERTENCIA



Improper installation, operation, adjustment, alteration, service or maintenance can cause property damage, injury or death. Read the installation and operating instructions thoroughly before installing, operating or servicing this equipment. / Toute mauvaise pratique en matière d'installation, de fonctionnement, de réglage, de

modification, d'entretien ou de maintenance peut causer des dommages matériels, des blessures ou la mort. Lisez la totalité des instructions d'installation et d'utilisation avant d'installer, d'utiliser ou d'entretenir cet équipement. / La indebida instalación, operación, ajuste, modificación, servicio o mantenimiento puede ocasionar daños a la propiedad, lesiones o muerte. Lea detenidamente las instrucciones de instalación y de operación antes de instalar, poner a funcionar o dar servicio a este equipo.



Do not lean on or place objects on lip. / Ne vous penchez pas sur ou ne placez pas des objets sur la lèvres. / No se apoye ni coloque objetos en el labio.



Hot product and surfaces. / Produit et surfaces chaudes. / Producto y superficies calientes.

Do not touch. / Ne pas toucher. / No la toque



Stand clear of product discharge path when discharging hot product. / Écartez-vous du chemin de décharge d'un produit chaud. / Permanezca alejado de la ruta de descarga del producto al vaciar producto caliente.



Keep hands away from moving parts and pinch points. / Gardez les mains loin des pièces mobiles et des points de pincement. / Mantenga las manos lejos de piezas móviles y puntos de presión muy localizada.



Inspect unit daily for proper operation. / Inspectez l'unité tous les jours pour son bon fonctionnement. / Inspeccione diariamente el funcionamiento correcto de la unidad.



Pressurized device. / Appareil sous pression. / Dispositivo de presión.

Keep clear of pressure relief discharge. / Restez à l'écart de la soupape de sureté. / Permanezca alejado de la descarga de presión.



Do not climb, sit or stand on equipment. / Il ne faut pas monter, s'asseoir ni se tenir debout sur l'équipement. / No subirse, ni sentarse ni pararse sobre el equipo.



Surfaces and product may be hot! Wear protective equipment. / Les surfaces et le produit peuvent être chauds! Portez un équipement de protection. / ¡Las superficies y el producto pueden estar calientes! Utilice equipo protector.



Heavy / Lourd / Pesado

Team or mechanical lift. / Équipe ou remontée mécanique. / Equipo o elevador mecánico.



Floor may become slippery from product spillage. / Déversement de produit peut causer de plancher à être glissante. / Derrame de producto puede causar piso a ser resbaladizo.



Unit must be anchored as per manual. / Unité doit être ancrée selon les directives du manuel. / Unidad debe estar fijado según el manual.



Do not fill kettle above recommended level marked on outside of kettle. / Ne remplissez pas la chaudière en excès du niveau recommandé marqué sur la chaudière. / No llene la marmita arriba del nivel recomendado marcado fuera de la marmita.



Heavy / Lourd / Pesado

Team or mechanical lift. / Équipe ou remontée mécanique. / Equipo o elevador mecánico.



Do not remove guards or operate without them. / Ne pas supprimer les gardes ou fonctionner sans eux. / No retire los guardias ni funcionar sin ellos.

SERVICING / ENTRETIEN / SERVICIO



Have a qualified service technician maintain your equipment. / Demandez à un technicien en entretien et en réparation qualifié d'effectuer l'entretien de votre équipement. / Haga que un técnico de servicio calificado mantenga su equipo



Ensure kettle is at room temperature and pressure gauge is showing zero or less prior to removing any fittings. / Assurez-vous que la chaudière est à température ambiante et que le manomètre est à zéro ou moins avant de retirer des accessoires. / Asegúrese de que la marmita esté a temperatura ambiente y el manómetro esté mostrando cero o menos antes de retirar cualquier accesorio.



Remove electrical power prior to servicing. / Coupez l'alimentation électrique avant l'entretien. / Desconecte la energía eléctrica antes de darle servicio.

Risk of electric shock. / Risque de choc électrique. / Riesgo de choque eléctrico.

INSTALLATION

GENERAL

Installation of the unit must be accomplished by qualified installation personnel working to all applicable local and national codes. Improper installation of product could cause injury or damage.

This unit is built to comply with applicable standards for manufacturers. Included among those approval agencies are: UL, NSF, ASME/Ntl.Bd., CSA, ETL, CE, and others. Many local codes exist, and it is the responsibility of the owner/installer to comply with these codes.

RECEIVING INSPECTION

Before uncrating, visually inspect the unit for evidence of damage during shipping.

If damage is noticed, do not unpack the unit, follow shipping damage instructions.

SHIPPING DAMAGE INSTRUCTIONS

If shipping damage to the unit is discovered or suspected, observe the following guidelines in preparing a shipping damage claim.

1. Write down a description of the damage or the reason for suspecting damage as soon as it is discovered. This will help in filling out the claim forms later. If possible, take a polaroid picture.
2. As soon as damage is discovered or suspected, notify the carrier that delivered the shipment.
3. Arrange for the carrier's representative to examine the damage.
4. Fill out all carrier claims forms and have the examining carrier sign and date each form.

APPROXIMATE WEIGHTS

Model #	Unit	Unit with shipping box
MKDT12T	168 lbs.	186 lbs.
MKDT20T	186 lbs.	206 lbs.



UNCRATING

Caution:

Straps under tension and will snap when cut.

Carton may contain staples and Skid contains Nails.

Use proper safety equipment and precautions.

Unit is heavy use adequate help or lifting equipment as needed.

1. Carefully cut any straps from container.
2. Lift off carton.
3. Inspect for hidden damage. If found refer to "SHIPPING DAMAGE INSTRUCTIONS".

4. Cut strap holding unit.
5. Remove manual from kettle pot. Write down the model# and serial# of the unit onto the front of this manual.
6. Lift kettle off skid and move kettle to its installation location.
7. Discard packaging material according to local and or state requirements.

VENTILATION

Operation of these units can produce significant levels of steam and condensate, it is recommended they be installed under a ventilation hood in a room which has provisions for adequate make up air. Further information can be obtained by referring to the U.S.A. National Fire Protection Associations NFPA96 regulations. These standards have also been adopted by the National Building Code in Canada.

POSITIONING

The first installation step is to refer to the Specification Sheets or Specification Drawings for detailed clearance requirements and mounting hole locations of the kettle.

1. Position on a firm, level surface, and bolt the four flange feet in place.
2. Install service requirements as required (see below).
3. Once the kettle is secure and service utilities installed, screw tilt handle into the threaded hole provided at the right side of kettle.

RECOMMENDED PIPING SCHEMATICS

(all service connections shown supplied by others)

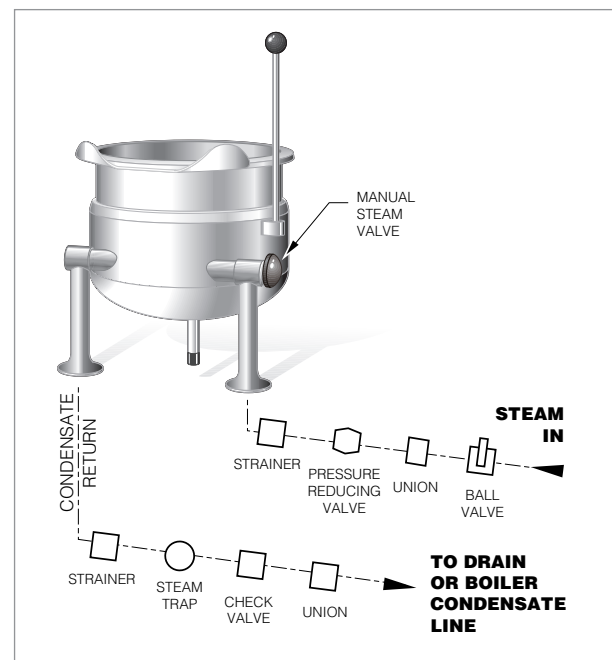

STEAM

All steam plumbing to and from the kettle and steam boiler should be thoroughly cleaned and inspected for dirt and debris before final connection to the kettle is made.

Generally, kettles require 1/2" i.p.s. pipe, 10-45 psi steam pressure. If the steam supply pressure exceeds 45 psi, a pressure reducing valve is required. The steam inlet is at the right side of the kettle, as seen from the front.

A pressure reducing valve is required on the incoming line as shown on RECOMMENDED PIPING SCHEMATICS. The relief valve should have a capacity of 300 lb/hr (136 kg/hr).

ELECTRICAL

ENSURE THE ELECTRICAL SUPPLY MATCHES THE KETTLE'S REQUIREMENTS AS STATED ON THE RATING LABEL.

This kettle is built to comply with applicable standards of manufacturers. Included among these approval agencies are UL, NSF, ASME/Ntl. Bd., CSA, ETL, and others. Many local codes exist, and it is the responsibility of the owner and installer to comply with these codes.

The electrical supply must match the power requirements specified on the kettle's rating plate. The copper wiring must be adequate to carry the required current at the rated voltage. Refer to the Specification Sheet for all electrical specifications.

Note: Maximum voltage for LVD (low volt directive for Europe) to be 440 volts for CE marked appliances

CONDENSATE

Maximum pressure rating on table-top kettles is 50psi. It is highly recommended that a pressure relief valve equal to or less than this pressure be installed on the incoming steam line close to the kettle.

A steam condensate trap must be plumbed to a drain, using minimum 1/2" NPT plumbing. The condensate line is limited to a maximum rise of 10 feet in order for the steam pressure to adequately force the condensate through the plumbing. Any higher rise requires a pump.

If the steam boiler to which this kettle is installed has a condensate return (closed loop system), a 1/2" steam strainer, a 1/2" steam trap, and a 1/2" check valve must be installed on the output (condensate) side of the kettle.

POTABLE WATER

The water faucet (optional on kettles purchased without SD stands) with swing spout, requires 1/2 inch O.D. copper tube plumbing for hot or cold water supplies to the faucet (SPK - cold water connection only, DPK - hot and cold water connection).

FINAL INSTALLATION CHECKS

Visual Checks

1. Check unit is bolted in place.
1. Check Marine Lock. See Marine Lock Testing Procedure.
2. Check Tilting:
 - A/ Handle is in place and firmly tightened.
 - B/ Kettle tilts smoothly and freely.
3. Insure there are:
 - A/ Four screws securely holding the console cover.
 - B/ The bottom cover is in place and held with a nut.

Performance Checks

1. Partially fill the kettle with water.
2. Slowly turn the steam supply valve's knob to the open position.
3. Release the safety valve, ensuring that the steam escapes freely. Stay clear of steam exhaust when releasing the safety valve.
4. Observe that the water in the kettle comes to a boil.
5. Close the steam supply valve.
6. Drain off the water by tilting the kettle

CLEANING

After installation the kettle must be thoroughly cleaned and sanitized prior to cooking. See Cleaning Instructions.

OPERATING INSTRUCTIONS



WARNING

If for any reason this unit is not functioning correctly **DO NOT OPERATE**.
Contact your authorized service agent.

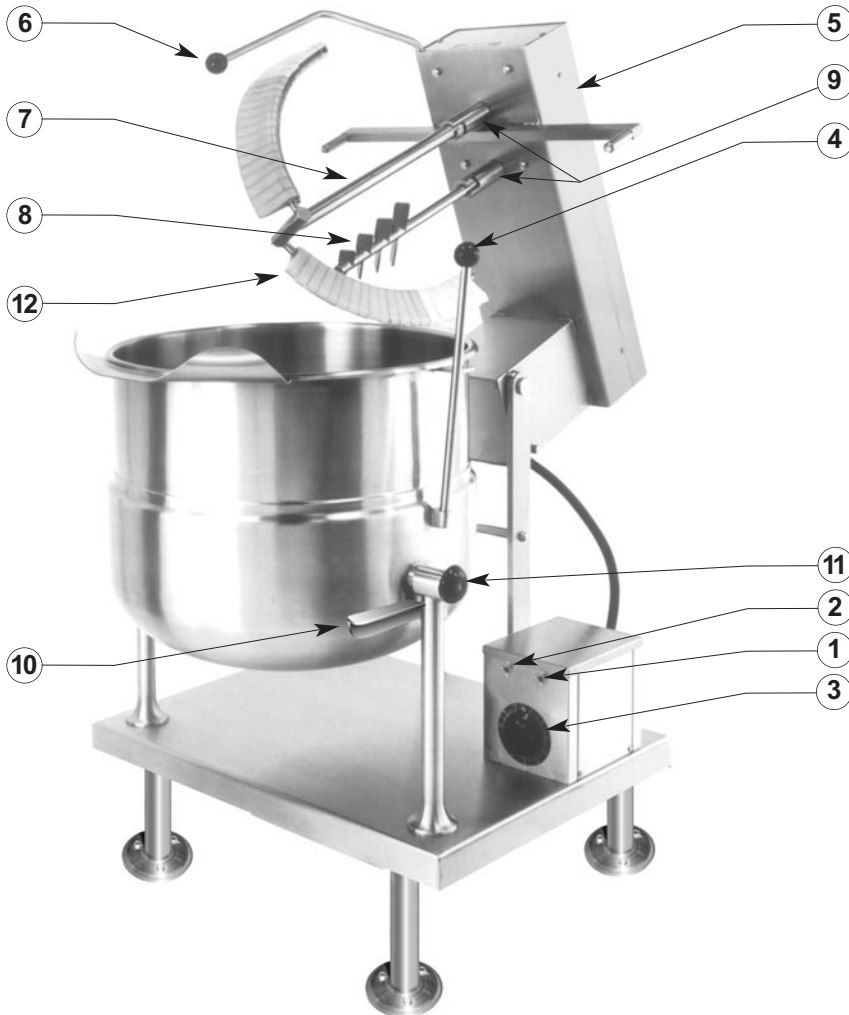

ITEM #	DESCRIPTION	FUNCTION
1.	On-Off Toggle Switch	Controls electrical power to unit.
2.	Mixer Start Switch	Starts mixing action.
3.	Agitator Speed Control Knob	This control allows the operator to select agitator speed increments from Min. to Max.
4.	Kettle Tilt Handle	Used for tilting the kettle.
5.	Mixer Bridge	Encloses agitator motors.
6.	Mixer Bridge Tilt Handle	Used for tilting mixer bridge.
7.	Main Agitator Arm	Provides most of the product movement.
8.	Secondary Agitator Arm	Provides reverse agitation and product lift in kettle.
9.	Bayonet Mounts for Agitator Arms	Allows removal of main and secondary agitator arms without tools.
10.	Marine Lock	Prevents unit from accidental tilting.
11.	Steam Control Valve	Manually controls the amount of steam entering the steam jacket.
12.	Scraper Blades	

OPERATING THE KETTLE



Intended Use:

Processing of food and pharmaceuticals in non-residential locations. Not for the making of dough or other heavy dough like products.

Intended Users:

- Supervised and trained staff during production periods.
- Trained maintenance and service personnel.

Removable component weights

Lbs (kg)	12 gal	20 gal
Main arm with blades	12 (5.4)	20 (9.1)
Secondary arm	12 (5.4)	15 (6.8)

Noise level

Noise level maximum 80 Decibels.

Mixing Arm Rotation speeds

Arm	Speed (RPM)
Primary	0-40
Secondary	0-210

Rim (loading) heights

Rim heights are given below. It is up to owners of the equipment to ensure the operators are performing the loading in a safe and acceptable manner.

MKDT12T		MKDT20T	
33"	38"	37"	42"

Emergency

In the event of a fire or other emergency.

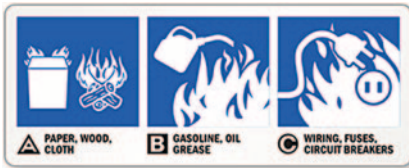

Turn off unit

Shut off power supplies including Electrical, Gas or Steam as applicable. (If safe to do so.)

Using fire extinguishers is only recommended if you are trained and feel safe to do so. Use only Fire extinguishers rated ABC.

This is a pressure vessel and with a properly operating safety valve will not exceed rated pressures. Jacket contains water and trace amounts of rust inhibitor and/or antifreeze.

MARINE LOCK -

(Tilt handle units)

Your unit is equipped with a marine lock to prevent accidental tilting. The following procedure should be used to tilt the kettle.

1. Grasp the tilt handle.
2. Hold the latch down to unlock tilting mechanism.
3. Pull the handle to tilt kettle.
4. To lock, return the kettle to its upright position and push handle back.



NOTE: Inspect lock daily to ensure it is free moving and does not bind or stick. Clean lock if necessary (see Cleaning Instructions for details)

OPERATION

1. Ensure that there is an adequate steam supply to the kettle.

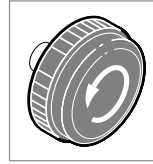

2. Turn the steam control valve to the open position by turning the knob counter-clockwise, then allow the kettle to preheat.

NOTE: When cooking egg and milk products, the kettle should NOT be preheated, as products of this nature adhere to hot cooking surfaces. These types of foods should be placed in the kettle before heating is begun.



3. Fill kettle with product to desired level.

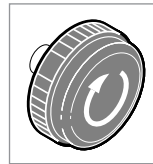

4. When the product has reached the desired temperature, regulate the heat, as required, by turning the steam control valve clockwise for less steam, and therefore, a lower temperature.

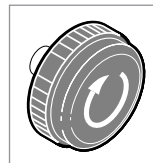

5. When cooking is complete, close the steam control valve by turning the knob clockwise.

6. Pour the contents of the kettle into an appropriate container by tilting the kettle forward.

MIXER OPERATION

1. Turn Mixer Start Switch to "ON".

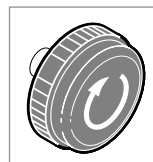

2. Adjust Steam Control Valve to desired setting.

CLEANING INSTRUCTIONS



CARE AND CLEANING

Cooking equipment must be cleaned regularly to maintain its fast, efficient cooking performance and to ensure its continued safe, reliable operation. The best time to clean is shortly after each use (allow unit to cool to a safe temperature).

WARNINGS



Do not use detergents or cleansers that are chloride based or contain quaternary salt.

Chloride Cleaners



Do not use a metal bristle brush or scraper.

Wire Brush & Scrapers



Steel wool should never be used for cleaning the stainless steel.

Steel Pads



Unit should never be cleaned with a high pressure spray hose.

High Pressure Spray Hose



Do not leave water sitting in unit when not in use.

Stagnant Water

CLEANING INSTRUCTIONS

1. Turn unit off.
2. Remove drain screen (if applicable). Thoroughly wash and rinse the screen either in a sink or a dishwasher.
3. Prepare a warm water and mild detergent solution in the unit.
4. Remove food soil using a nylon brush.
5. Loosen food which is stuck by allowing it to soak at a low temperature setting.
6. Drain unit.
7. Rinse interior thoroughly.
8. Using mild soapy water and a damp sponge, wash the exterior, rinse, and dry.

NOTES

- ⇒ For more difficult cleaning applications one of the following can be used: alcohol, baking soda, vinegar, or a solution of ammonia in water.
- ⇒ Leave the cover off when the kettle is not in use.
- ⇒ For more detailed instructions refer to Stainless Steel Equipment Care and Cleaning (www.nafem.org/resources/stainlesssteelfinal.doc) on Nafem's website (www.nafem.org).



DISPOSAL INSTRUCTIONS

This unit is recyclable. Do not dispose in landfill.

The majority of the unit is composed of stainless steel. Other alloys and electrical components make up a small percentage of the total. Follow Federal, state and local regulations for disposal.

PREVENTATIVE MAINTENANCE

**FOR MAINTENANCE AND REPAIRS CONTACT YOUR AUTHORIZED
MANITOWOC SERVICE AGENCY AND HAVE A QUALIFIED SERVICE
TECHNICIAN MAINTAIN YOUR EQUIPMENT.**



WARNING

If for any reason this unit is not functioning correctly **DO NOT OPERATE.**
Contact your authorized service agent.

Refer to maintenance procedures and parts list manual
for detailed maintenance and testing instructions.



DAILY PRE-STARTUP INSPECTION

1. Kettle tilts smoothly.
2. Kettle tilt lock is functioning correctly and is not binding, sticking or loose.
3. Kettle is securely mounted in place.
4. Handle is tight and knob is in place.

SIX MONTH SERVICE INSPECTION

1. Perform daily startup inspection.
2. If unit is on a stand inspect stand for proper installation and stand is securely mounted to floor.
3. Test pressure relief valve.
4. Clean strainers.
5. Inspect for steam leaks.

MAINTENANCE

ALL SERVICE MUST BE PERFORMED BY A QUALIFIED SERVICE TECHNICIAN.

This kettle requires very little preventative maintenance other than daily cleaning. The pressure relief valve must be tested twice a year.

PRESSURE RELIEF VALVE TESTING PROCEDURE

WARNING
Kettle will be hot. Use gloves for protection.

The pressure relief valve (optional on kettles) must be checked at least twice a year as part of the normal maintenance performed.

1. Open steam valve and preheat kettle.
2. Stand to the side of the pressure relief valve discharge tube and pull ring three or four times to insure free movement. Hold valve open for two seconds each time, insuring there is rapid steam escape each time.
3. If valve appears to be sticking replace pressure relief valve. If foreign material is discharged, replace pressure relief valve and eliminate the source of contamination.

STEAM TRAP

To remove line condensate that forms inside the steam jacket, each kettle should be equipped with a steam trap in the line of the kettle outlet to the drain. A good steam trap at startup releases air and wet steam into the drain line for a few minutes, then holds the steam jacket. During cooking, the trap periodically releases accumulated condensate. If the kettle's cooking performance becomes inadequate after long use, replacement of the steam trap with a new one may restore kettle operation to peak efficiency.

MARINE LOCK

Inspect lock at least twice yearly.

1. Check for excessive play or wear on pivot. Adjust or replace as required.
2. Insure lock is catching over the centre of the stop pin and not bent to one side or the other. Adjust or replace as required.

WARRANTY

Our Company supports a worldwide network of Maintenance and Repair Centers. Contact your nearest Maintenance and Repair Centre for replacement parts, service, or information regarding the proper maintenance and repair of your cooking equipment

In order to preserve the various agency safety certification (UL, NSF, ASME/Ntl. Bd., etc.), only factory-supplied replacement parts should be used. The use of other than factory supplied replacement parts will void warranty.

TROUBLESHOOTING GUIDE

This section contains information intended for use by Authorized Service Personnel only.

PROBLEM

A/ Kettle heats too slowly or does not come to a boil.

Probable Cause

1. Inadequate steam flow.
2. Steam trap not operating properly.
3. Food batches are not always the same.

Remedy

Check for correct steam using chart below.
 If kettle is connected to a steamer and powered by a generator the units should be operated sequentially (kettle boiling first, then start steamer).
 The trap should open periodically to dump condensate, then close.
 If it does not open or close it should be cleaned or replaced.
 When checking make certain that the original state (ie. fresh or frozen) and quantity of food product is the same.

PROBLEM

B/ The trunnion housing leaks steam.

Probable Cause

1. Trunnion "O" rings are worn.

Remedy

Replace "O" rings (see Steam Control Assembly drawing).

STEAM FLOW RATING OF STEAM GENERATORS

Gas Input BTU/Hour	Steam Output Lbs./Hour	Boiler H.P.
100,000	60	1.7
160,000	95	2.8
200,000	125	3.6
250,000	150	4.4
300,000	180	5.2
Electric		
KW Input		
18	60	1.7
24	70	2.0
27	90	2.6
36	120	3.5
48	150	4.4

STEAM FLOW RATING REQUIREMENTS FOR KETTLES

Capacity Gal./Lit.	Fast Cooking	Medium Cooking	Stock Kettle
6/17	11	9	6
12/42	22	18	11

Above shows lbs. per hour with 10-15 psig steam at the kettle. The use of higher steam pressures (20-25 psig) will reduce heat-up time 5-20%.

WIRING DIAGRAM

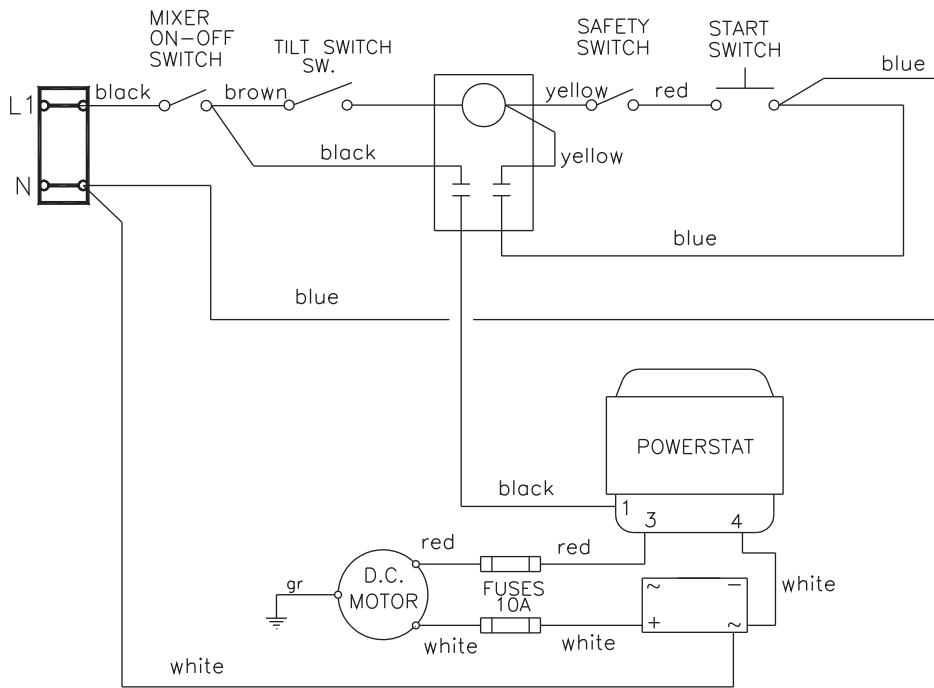

MKDT DIRECT STEAM
TABLETOP KETTLE KE90334-1 C
120 VOLT

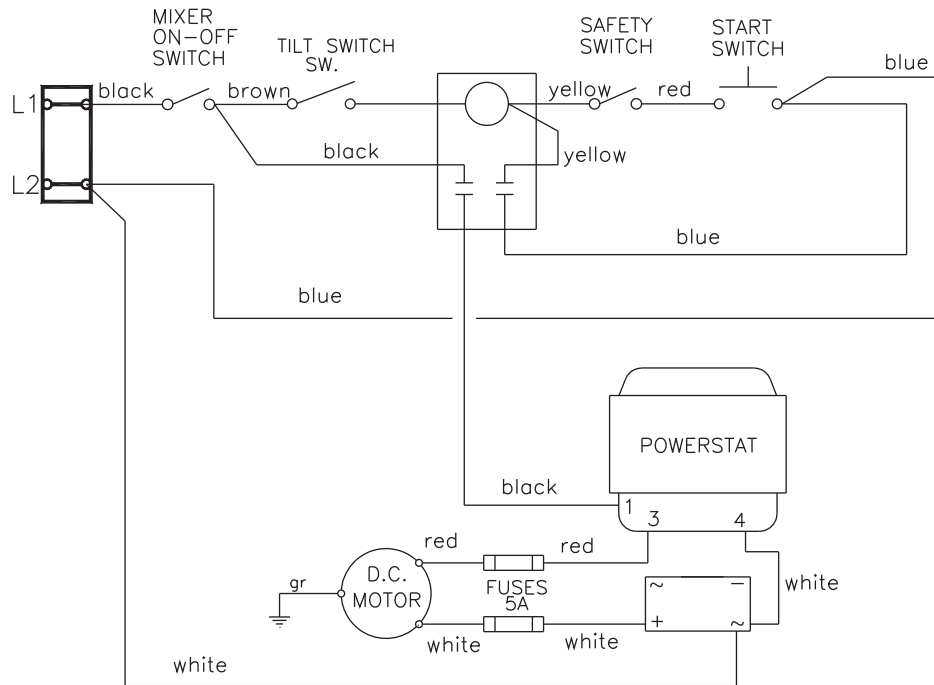

MKDT DIRECT STEAM
TABLETOP KETTLE KE90334-2 C
220 VOLT

SERVICE PARTS

WARRANTY

Our Company supports a worldwide network of Maintenance and Repair Centers. Contact your nearest Maintenance and Repair Centre for replacement parts, service, or information regarding the proper maintenance and repair of your cooking equipment

In order to preserve the various agency safety certification (UL, NSF, ASME/Ntl. Bd., etc.), only factory-supplied replacement parts should be used. The use of other than factory supplied replacement parts will void warranty.

FAUCET ASSEMBLY

ITEM NO.	PART NO.	DESCRIPTION	QTY.
1.	KE50825-2	3/4" Spout (KET-3/6/12/20-T)	1
	KE50825-9	3/4" Spout (TKET-3/6/12-T)	1
2.	FA95022	Retaining Ring	1
3.	FA05002-19	"O" Ring	1
4.	KE51736	Long Faucet Nut	1
5.	SE50020	Hot Water Stem Assembly	1
		(Double Pantry only)	
6.	SE50021	Cold Water Stem Assembly	1
7.	KE51401	Single Pantry Body	1
		(c/w Item No. 6)	
8.	KE50335	Adapter Washer	1
		(Single Pantry only)	
9.	KE51403	Double Pantry Body	1
		(c/w Item No. 5&6)	
10.	KE54159	Faucet Mounting Bracket	1
11.	FA11258	Hex Cap Screw	2
12.	FA30505	Washer	2
13.	FA21008	Hex Nut	2
14.	SE50447	Washer Horseshoe	1

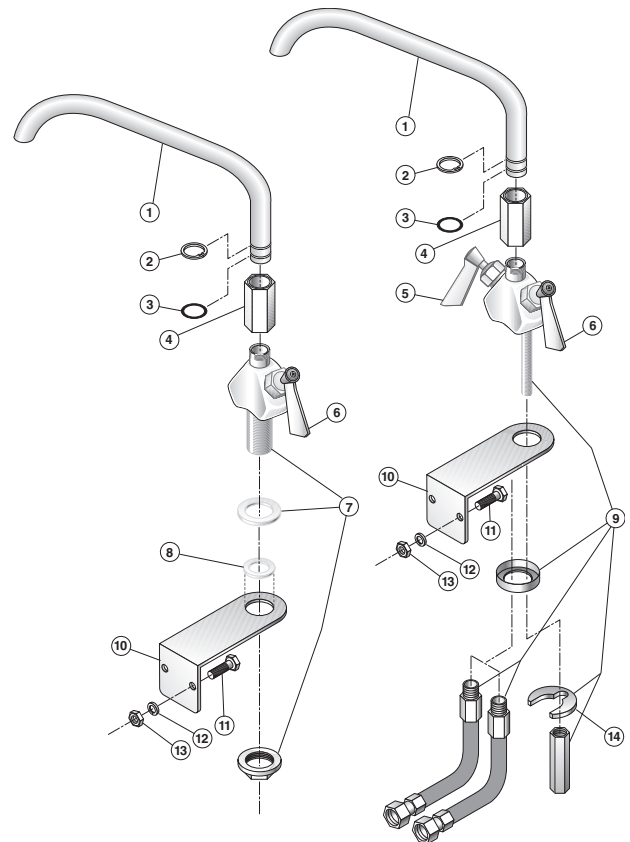

CONTROL HOUSING

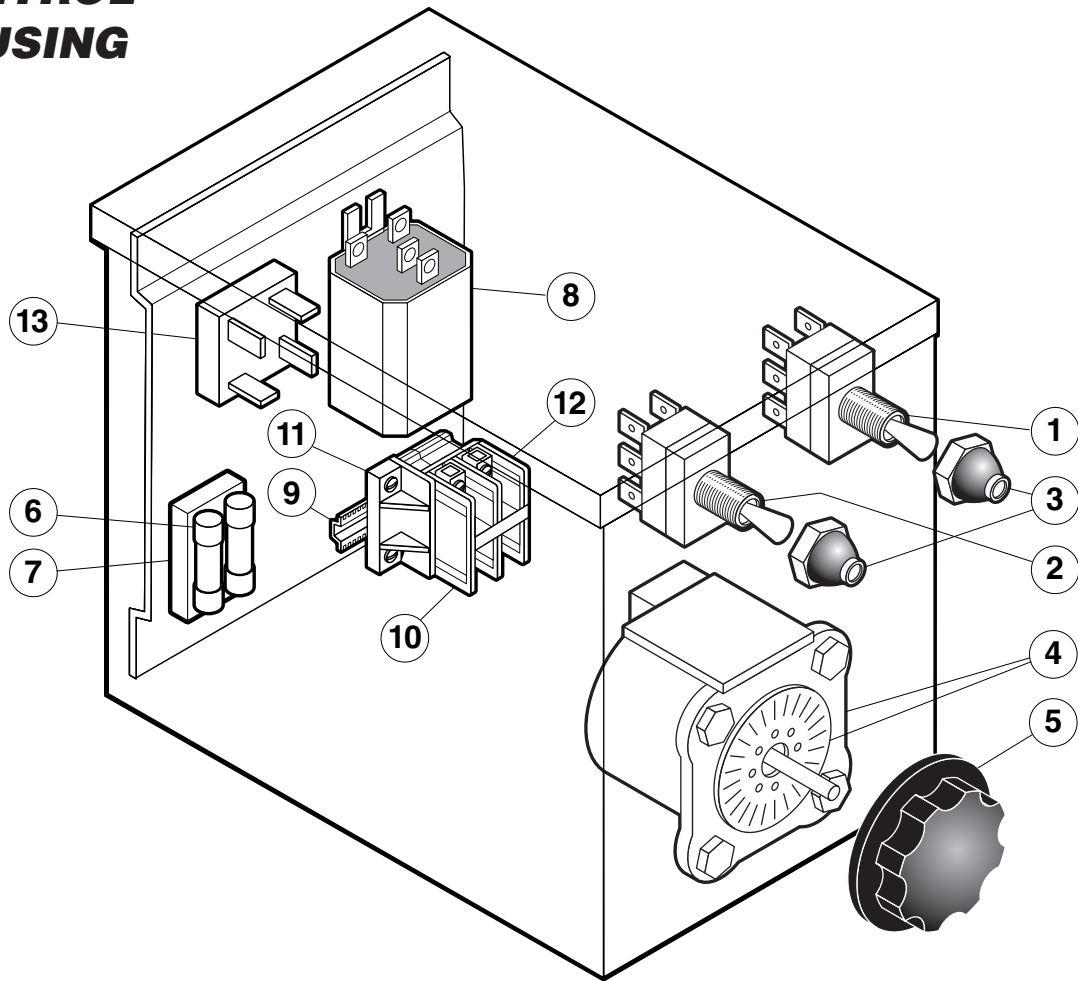

ITEM NO.	PART NO.	DESCRIPTION	QTY.
1.	KE51955	Switch, Toggle, Momentary	1
2.	KE50504	Switch, Toggle, SPST	1
3.	SK50062	Rubber Boot	2
4.	KE01130	Powerstat, 120 V	1
5.	KE52190	Knob, Speed Control	1
6.	KE51919	Fuse, 10 Amp. (115v motor)	2
	KE51920	Fuse, 5 Amp. (230v motor)	2
7.	KE51139	Fuse Holder (single)	2
	KE51228	Fuse Holder (double)	2
8.	KE0753-1	Relay, 12 VAC	1
9.	KE54761	Terminal Block Mounting Strip	1
10.	SK50055-1	Terminal Block	3
11.	SK50054-2	Terminal Block End Anchor	1
12.	SK50054-1	Terminal Block End Barrier	1
13.	KE50581	Bridge Rectifier	1

STEAM CONTROL ASSEMBLY

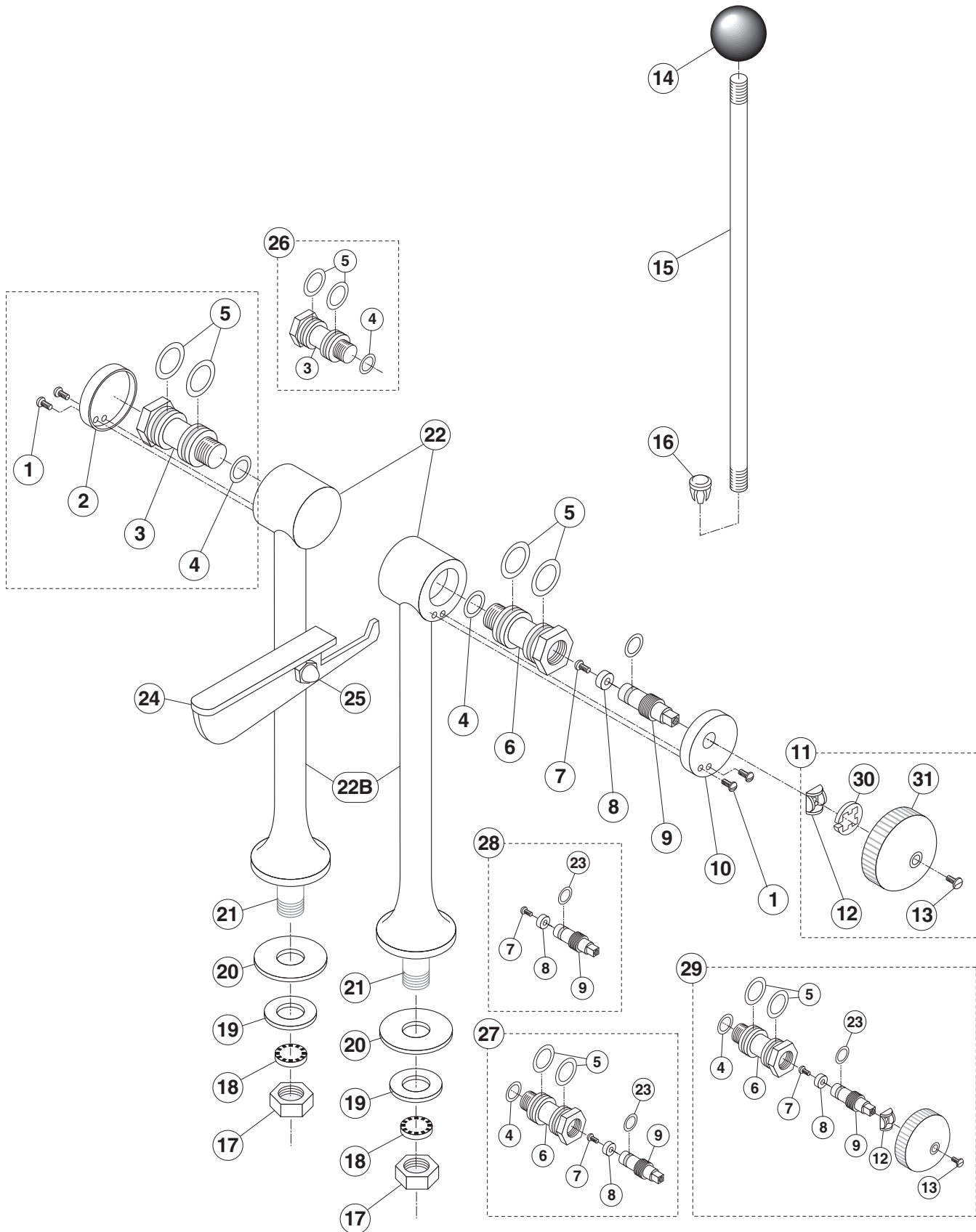

STEAM CONTROL ASSEMBLY

ITEM NO.	PART NO.	DESCRIPTION	QTY.
1.	FA11056	Binding Head Screw, 6-32 x 1/2" Ig.	4
2.	KE50458	End Cap, condensate return	1
3.	KE50455-1	Trunnion, condensate return	1
4.	FA05002-35	"O" Ring	2
5.	FA05002-37	"O" Ring	4
6.	KE50460-1	Trunnion, steam inlet	1
7.	FA11089	Binding Head Screw, 8-32 x 1/4" Ig.	1
8.	KE51713	Washer, steam valve	1
9.	KE50459	Operating Stem	1
10.	KE50457	End Cap, steam inlet	1
11.	SE00028	Steam Control Knob Assembly (c/w Item No. 12, 13 & Knob)	1
12.	KE51888	Retaining Washer	1
13.	FA11092	Binding Head Screw, 8-32 x 1/2" Ig.	1
14.	KE50151-E	Knob, threaded (after 07/94)	1
	KE50151	Knob, non threaded (prior to 06/94)	1
15.	KE50886-3	Handle, KDT-6-T & KDT-12-T	1
	KE50886-4	Handle, KDT-20-T	1
16.	KE50475	Plug Button	1
17.	KE52697	Lock Nut, 1/2" NPS	2
18.	FA32500	Lockwasher	2
19.	FA30502	Washer, satin coat	2
20.	KE50467	Washer, Foot	2
21.	KE50463	Service Pipe, KDT-12-T	2
	KE50464	Service Pipe, KDT-20-T	2
22.	KE00203	Leg Assembly	2
23.	FA05002-12	"O" Ring	1
24.	KE01115	Marine Lock Latch	1
25.	KE52632	Crown Nut	1
26.	SE00096	Steam Outlet Assembly	1
27.	SE00011	Trunnion Assembly, steam inlet	1
28.	SE00029	Operating Stem Assembly, steam inlet	1
29.	SE00030	Steam Inlet Control Assembly	1

Requires Knob -
Item No. KE50151-E

BRIDGE ASSEMBLY

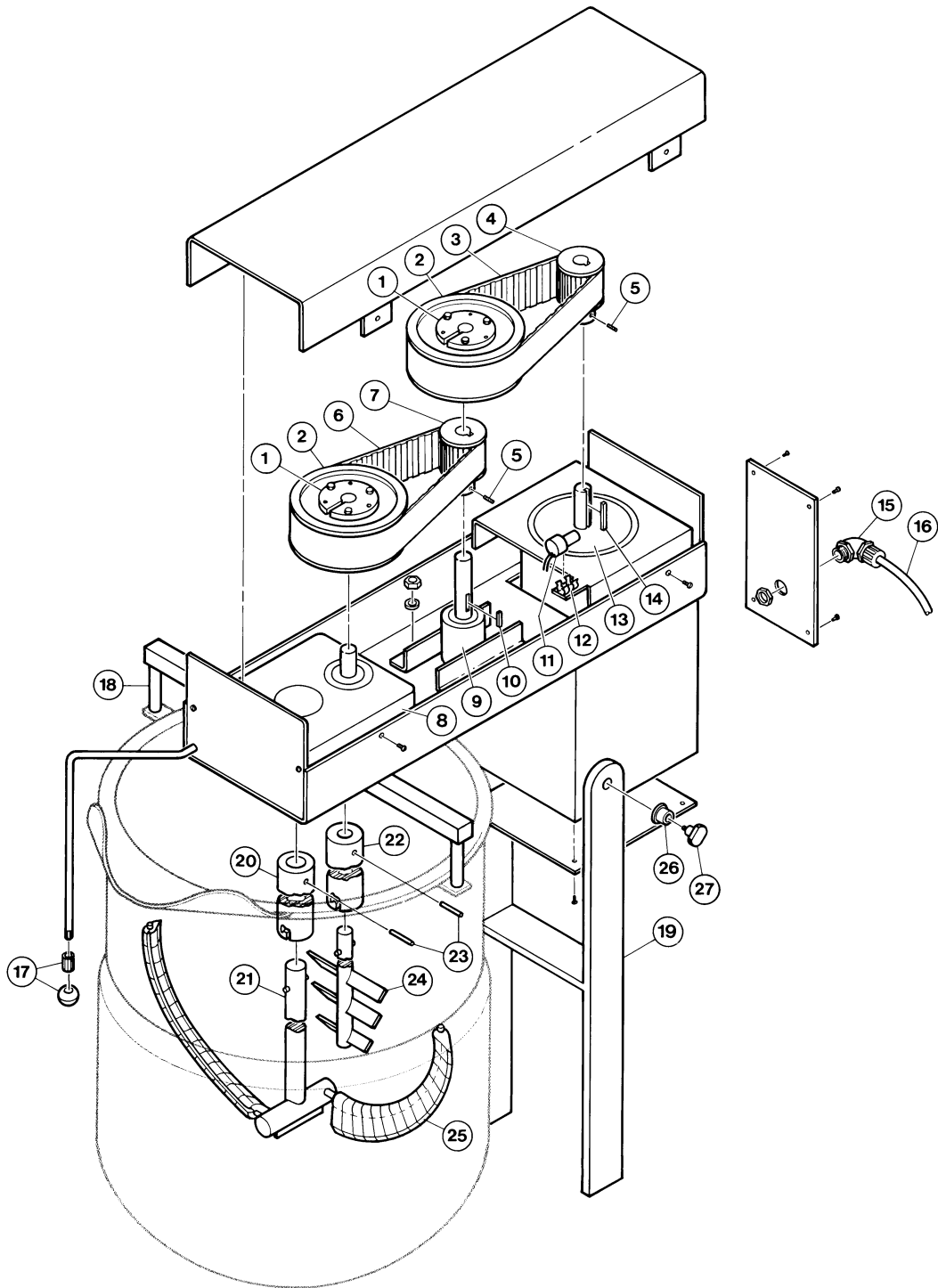

BRIDGE ASSEMBLY

ITEM NO.	PART NO.	DESCRIPTION	QTY.
1	KE50342	Bushing, Taper Lock	2
2	KE50284	Pulley, Large	2
3	KE51763	Belt (MKDT-12-T)	1
	KE51808	Belt (MKDT-20-T)	1
4	KE50285	Pulley, Small	1
5	FA19094	Set Screw, 12 - 24 x 3/8"	2
6	KE51763	Belt (MKDT-12-T)	1
	KE51807	Belt (MKDT-20-T)	1
7	KE51764	Pulley, Small	1
8		See Gear Box Detail	1
9	KE00773	Speed Reducer	1
10	FA95037	Key, 3/16' x 3/16' x 3/4'	1
11	KE50294	Switch, Mercury	1
12	KE50295	Bracket, Mercury Switch	1
13	KE51962	Motor, D.C. 3/4 H.P., 120 V	1
	KE51963	Motor, D.C., 3/4 H.P., 240 V	1
14	FA95014	Key, 3/16' x 3/16" x 1	1
15	KE51900	Connector, Conduit	1
16	KE51916	Conduit (MKDT-12-T)	1
	KE51917	Conduit (MKDT-20-T)	1
17	KE50151	Knob, Handle	1
18	KE51801	Pin, Bridge Support (MKDT-12-T)	1
	KE51802	Pin, Bridge Support (MKDT-20-T)	1
19	KE00847	Bridge Support Post (MKDT-12-T)	1
	KE00848	Bridge Support Post (MKDT-20-T)	1
20	KE51809	Coupling, Primary Shaft	1
21	KE00831	Agitator, Primary (MKDT-12-T)	1
	KE00832	Agitator, Primary (MKDT-20-T)	1
22	KE51810	Coupling, Secondary Shaft	1
23	FA95038	Pin, Agitator Coupling Taper	2
24	KE00829	Agitator, Secondary (MKDT-12-T)	1
	KE00830	Agitator, Secondary (MKDT-20-T)	1
25	KE51833	Scraper Blade	24,34
26	KE51965	Bushing, Bridge Pivot	2
27	KE52025	Pin, Bridge Pivot	2

GEAR BOX

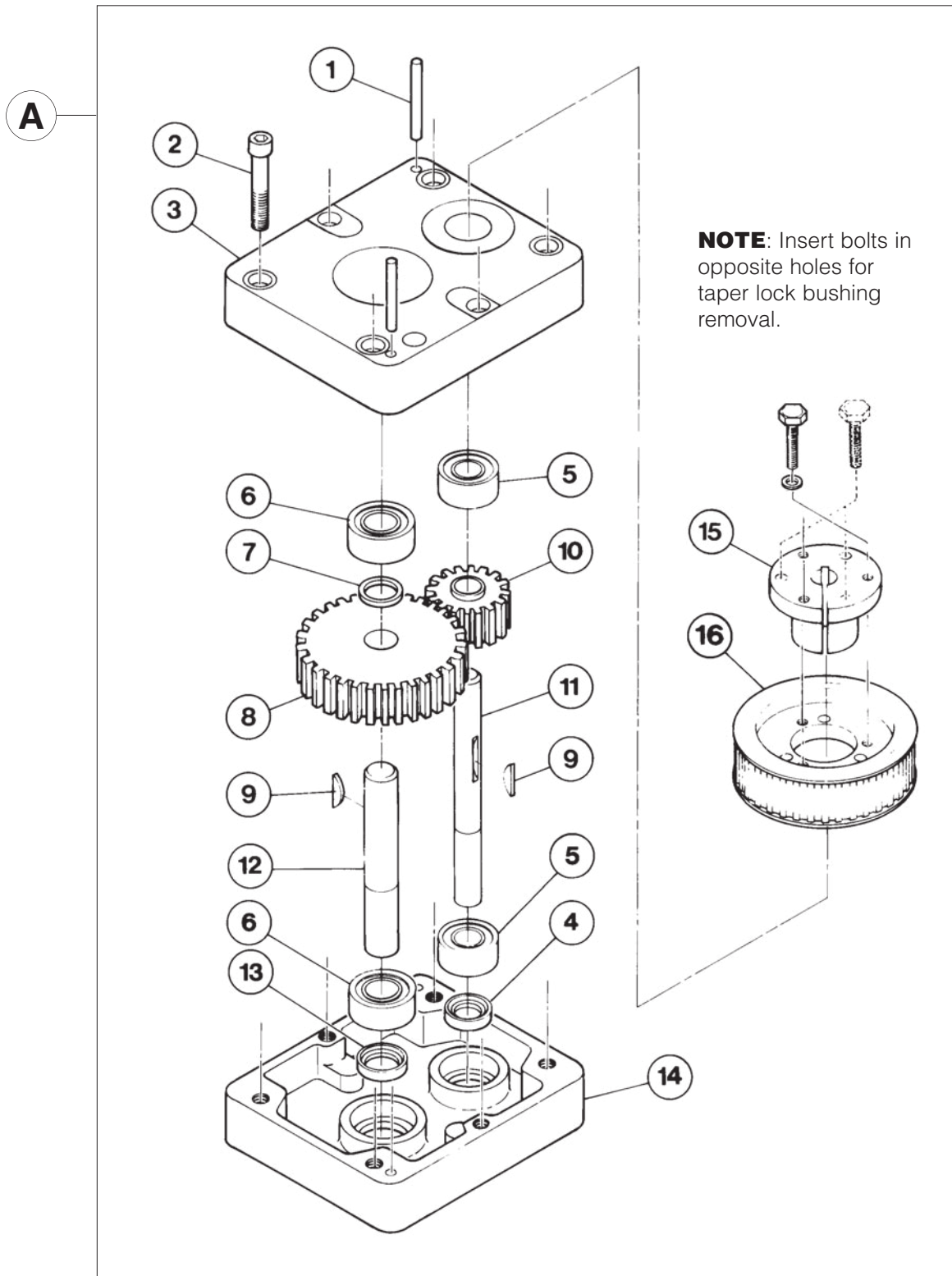

GEAR BOX

<i>ITEM NO.</i>	<i>PART NO.</i>	<i>DESCRIPTION</i>	<i>QTY.</i>
A	KE00107	Complete Assembly, MKDT-12-T	.1
	KE00104	Complete Assembly, MKDT-20-T	.1
1	FA95039	Dowel Pin, 1/4" x 28 (MKDT-12-T)	.2
	FA95004	Dowel Pin, 3/8" x 3" (MKDT-20-T)	.2
2	FA11510	Screw, Socket Head Cap, 5/16-18 UNCx 1-3/4"	.4
	FA10776	Screw, Socket Head Cap, 3/8 - 16 UNC x 2-1/2"	.4
3	KE51966	Upper Body Casing (MKDT-12-T)	.1
	KE50265	Upper Body Casing (MKET-20-T)	.1
4	KE50268	Bushing, Small Gear	.1
5	KE50266	Bearing, Small Gear	.2
6	KE50259	Bearing, Large Gear	.2
7	KE51245	Spacer (MKDT-12-T)	.1
8	KE50299	Gear, Large Spur (MKDT-12-T)	.1
	KE00105	Gear, Large Spur (MKDT-20-T)	.1
9	FA95003	Key, Woodruff	.2
10	KE00106	Gear, Small Spur	.1
11	KE50264	Shaft, Driving	.1
12	KE50261	Shaft, Driven (MKDT-12-T)	.1
	KE50260	Shaft, Driven (MKDT-20-T)	.1
13	KE50269	Bushing, Large Gear	.1
14	KE51967	Lower Body Casing (MKDT-12-T)	.1
	KE50267	Lower Body Casing (MKDT-20-T)	.1
15	KE50342	Bushing, Taper Lock	.1
16	KE50284	Pulley, Large	.1

Every new piece of Welbilt Foodservice equipment comes with KitchenCare® and you choose the level of service that meets your operational needs from one restaurant to multiple locations

StarCare – Warranty & lifetime service, certified OEM parts, global parts inventory, performance audited

ExtraCare — CareCode, 24/7 Support, online/mobile product information

LifeCare – Install & equipment orientation, planned maintenance, KitchenConnect™, MenuConnect®

Talk with KitchenCare® • 1-844-724-CARE • www.mtwkitchencare.com



To learn how Welbilt Foodservice and its leading brands can equip you, visit our global web site at www.welbilt.com, then discover the regional or local resources available to you.