



## **COOK/CHILL HORIZONTAL AGITATOR STATIONARY MIXER KETTLES**

- MODELS:**  HA-MKDL-60-CC  HA-MKDL-200-CC  
 HA-MKDL-100-CC  HA-MKDL-300-CC  
 HA-MKDL-150-CC



### **Cleveland Standard Features**

- Full 60, 100, 150, 200 or 300 gallon working capacity
- Electrically driven, Horizontal Agitator Mixer Arm
- Variable mixer speed control
- Spring loaded blades scrape entire heated surface area
- Internal mixing fins for most efficient, uniform mixing, heating and cooling
- Flush mounted, easily removable temperature probe
- Simmer control for cooking delicate products
- 3" diameter air operated, flush mounted piston draw-off valve (requires air compressor)
- Spiral flights for even water cooling
- Easily removable agitator without the use of tools
- Spring assist, one piece cover (bifold cover with counterweight for 300 gallon model)
- Heavy duty rim bar
- 100 psi steam jacket rating and safety valve
- Type 316 stainless steel for all food contact surfaces
- Water fill faucet with swing spout
- Kettle mounted valve box for single point utility connections
- NSF approved
- Accepted for use in USDA inspected facilities

**Note: This COOK/CHILL mixer kettle requires a control panel for operation. (Please specify remote mounted control center or kettle mounted control center.)**

### **Standard Features for Kettle Control Center:**

- Solid State temperature control with digital read-out
- Time/Temperature Chart Recorder to provide permanent record of Batch Processing
- Automatic and manual steam control
- Automatic and manual jacket water cooling
- Simmer control for delicate products
- Automatic water meter with accumulative "add on" button and digital readout
- U.L. approved

### **Options & Accessories**

- Single or dual remote control center
- Kettle mounted control center (100 gal. and larger)
- Dolly for horizontal agitator
- Stainless steel bifold hinged cover

ITEM NUMBER \_\_\_\_\_

JOB NAME / NUMBER \_\_\_\_\_



### **Short Form Specifications**

Shall be CLEVELAND Model HA-MKDL-\_\_-CC; COOK/CHILL STATIONARY HORIZONTAL MIXER KETTLE, \_\_ gallons; leg mounted; 2/3 jacketed, direct steam; 100 psi Steam Jacket Pressure Rating; 316 Stainless Steel Liner; electrically driven Horizontal Agitator; Variable Mixer Speed Control; 3" diameter air operated, flush mounted Piston Draw-Off Valve; spring loaded Scraper Blades; flush mounted Temperature Probe; Automatic Water Meter with Digital Readout; Water Fill Faucet with swing spout; Time/Temperature Chart Recorder (located in Control Center); Spring Assist, one piece Cover (bifold cover with counterweight for 300 gallon model).

- Tilting models
- 3" flush mounted ball valve
- Loading bucket and dolly
- Jacket pressure ratings other than standard
- Electric chain hoist for lifting the product load

MINIMUM CLEARANCE FOR KETTLES	
FRONT	36"
SIDE	12"
REAR	12"

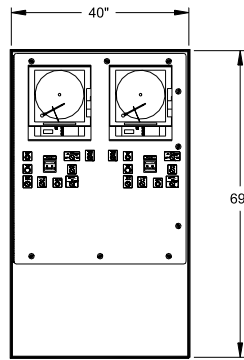
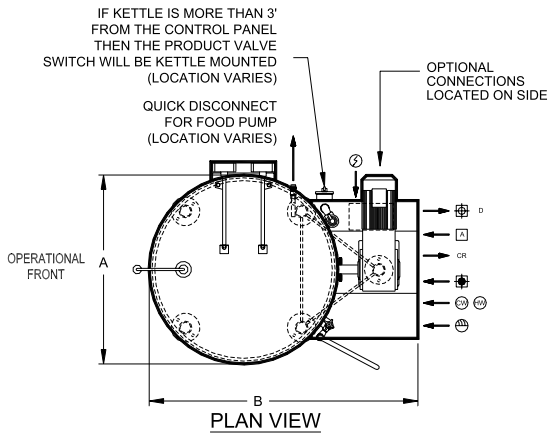

HA-DE-CC2  
DUAL CONTROL PANEL

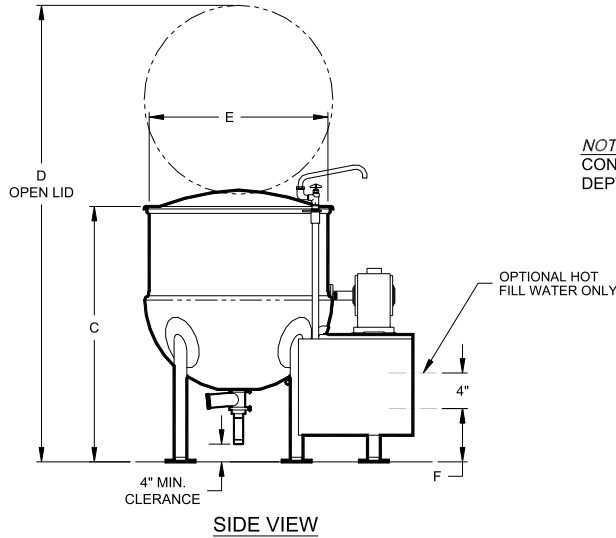

NOTE:  
CONTROL PANEL  
DEPTH 18 3/4"

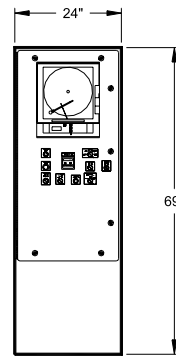

HA-SE-CC2  
SINGLE CONTROL PANEL

- ELECTRICAL POWER TO AND FROM CONTROL PANEL**
- CONTRACTOR MUST CUT ENTRY HOLE
  - TOP OR BOTTOM POWER ENTRY RECOMMENDED
  - MUST USE PROPER CONNECTIONS TO MAINTAIN U.L. LISTING

**DIMENSIONS**

MODEL	A	B	C	D	E	F	<b>ELECTRICAL PER KETTLE - 208V/3PH/60Hz</b>	R.P.M.
HA-MKDL-60-CC	32 1/2"	50 3/4"	47"	83"	29 1/2"	8"	12 AMPS	4-25
HA-MKDL-100-CC	38 5/16"	57"	52"	93"	35"	9"	15 AMPS	3-22
HA-MKDL-150-CC	43"	62"	57 1/2"	101"	40"	9"	25 AMPS	3-20
HA-MKDL-200-CC	48"	65 3/4"	62"	111"	45"	9"	25 AMPS	3-20
HA-MKDL-300-CC	53"	76 3/8"	67 1/2"	100"	50"	11"	30 AMPS	3-17

**UTILITY CONNECTIONS**

MODEL	CHILLED WATER INLET	CHILLED WATER RETURN	COLD POTABLE WATER	** HOT WATER	CONDENSATE RETURN	DRAIN	AIR INLET	STEAM
					CR	D		
HA-MKDL-60-CC	3/4" 15 GPM	3/4"	1/2" 15 GPM	1/2" 15 GPM	1/2"	3/4"	1/2" 1 CFM	3/4" 320 lbs/hr
HA-MKDL-100-CC	1" 20 GPM	1"	3/4" 20 GPM	3/4" 20 GPM	3/4"	1"	1/2" 1 CFM	1" 525 lbs/hr
HA-MKDL-150-CC	1 1/4" 20 GPM	1 1/4"	3/4" 20 GPM	3/4" 20 GPM	1"	1 1/4"	1/2" 1 CFM	1 1/4" 780 lbs/hr
HA-MKDL-200-CC	1 1/4" 25 GPM	1 1/4"	3/4" 20 GPM	3/4" 20 GPM	1"	1 1/4"	1/2" 1 CFM	1 1/4" 1050 lbs/hr
HA-MKDL-300-CC	1 1/2" 30 GPM	1 1/2"	3/4" 20 GPM	3/4" 20 GPM	1"	1 1/2"	1/2" 1 CFM	1 1/2" 1575 lbs/hr

**\*\* HOT FILL WATER IS OPTIONAL  
65 PSI STEAM OPERATING PRESSURE IS RECOMMENDED**

# J. C. PARDO & SONS, Inc.

*Stainless Steel and Nickel Fabricators*

*Manufacturers of Steam Jacketed Kettles and Tanks*



1250 REAMES ROAD, OFF PULASKI HWY.

TELEPHONE: 391-3600 - 391-3603  
(AREA CODE 410)

BALTIMORE, MARYLAND 21220

## INSTALLATION INSTRUCTIONS

1. WHEN REMOVING THE KETTLE FROM THE PLATFORM, HANDLE WITH CARE TO PREVENT SCRATCHING OR ANY OTHER DAMAGE. IT IS IMPERATIVE THAT THE KETTLE BE LEVEL BEFORE BOLTING TO THE FLOOR. THIS WILL PREVENT ANY TWIST OR OUT OF ROUNDNESS TO THE KETTLE AND WILL STOP DEFLECTION OF THE AGITATOR. MAKE SURE THE KETTLE IS SECURELY BOLTED TO THE FLOOR AND FOLLOW THE PRECEDURE LISTED BELOW:
  - A. RAISE THE FLANGE ON THE LEG OR LEGS UNDER THE MOTOR SO THAT IT SETS FREELY.
  - B. BECAUSE MOST FLOORS HAVE A PITCH TO ALLOW FOR DRAINING THE FLANGES CAN ONLY BE LOWERED APPROXIMATELY 1" DOWNWARD. IF THERE IS ANY VOD BETWEEN THE FLANGE AND THE FLOOR YOU MUST USE SHIMS TO FILL UP THE SPACE.
  - C. LOWER THE FLANGE OR FLANGES UNDER THE MOTOR CHANNEL. OVER ADJUSTMENT, WHETHER UP OR DOWN, COULD CAUSE MISALIGNMENT AND CUASE DAMAGE TO THE AGITATOR DRIVE SHAFT AND HUB. WHEN THIS IS COMPLETED YOU ARE THEN READY TO BOLT THE FLANGE OR FLANGES TO THE FLOOR.
2. NEXT YOU MUST CHECK THE ALIGNMENT OF THE DRIVE SHAFT FOR A UNIFORM CLEARANCE BETWEEN THE HUB AND THE SHAFT. IN ORDER

TO CHECK FOR CLEARANCE YOU MUST REMOVE THE SEAL COVER  
PLATE AND PULL THE SEAL BACK. YOU CAN CHECK THE DISTANCE  
FOR CLEARANCE BY USING A WIRE FEELER GUAGE.

3. IF ADJUSTMENT IS REQUIRED FOR SIDE DIRECTION, LOOSEN THE  
MOTOR BOLTS, CENTER THE SHAFT AND RETIGHTEN.

IF VERTICAL ALIGNMENT IS NEEDED, LOOSEN THE MOTOR BOLTS AND  
ADD A SHIM TO RAISE OR REMOVE A SHIM TO LOWER. RETIGHTEN  
BOLTS. WHEN THIS IS COMPLETE, CHECK TO SEE IF THE AGITATOR  
SHAFT COUPLING SLIDES FREELY FOR EASY REMOVAL OF THE AGI-  
TATOR.

NOTES:

AFTER UNIT IS LEVEL, ANCHOR ALL FLOOR FLANGES TO THE FLOOR BY USING AN ANCHOR BOLT IN EACH HOLE OF THE FLANGES.

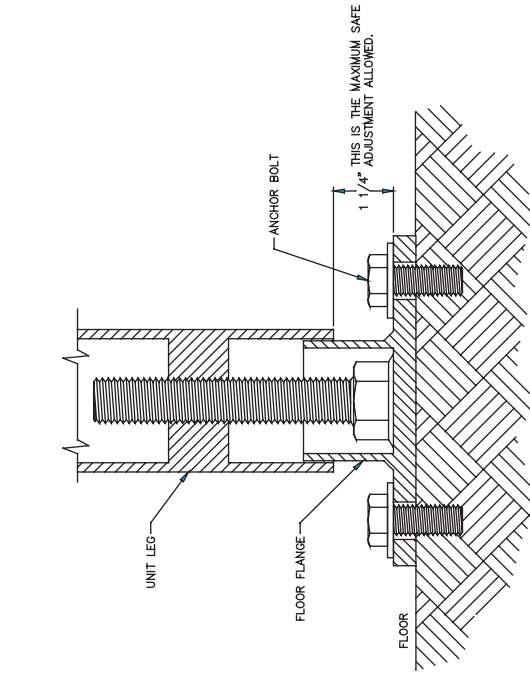

CORRECT ADJUSTMENT  
OF FLOOR FLANGE

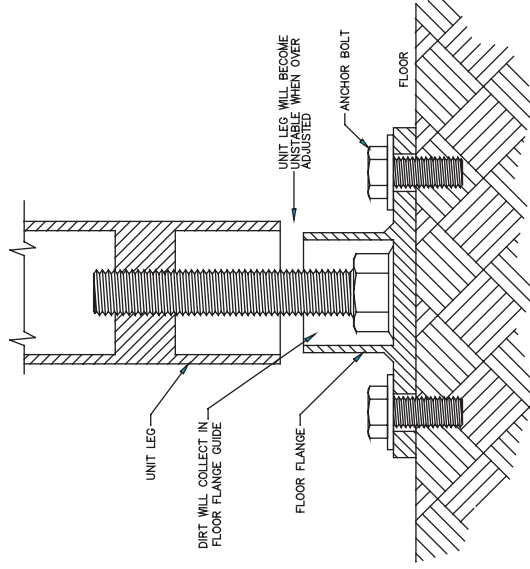

INCORRECT ADJUSTMENT  
OF FLOOR FLANGE

**J.C.PARDO & SONS INC.**



1250 REAMES RD. BALTO MD. 21220  
PHONE (410) 391-3600 FAX (410) 391-9042

DRAWN BY: JAY S.

DATE: 4-27-96

SCALE: NONE

CHECKED BY:

APPROVED BY:

2" TO 2 1/2" FLOOR FLANGE  
ADJUSTMENT INSTRUCTIONS

This drawing and all information contained therein is the property of J.C. Pardo & Sons, Inc., Balto, MD. The drawing and all information is confidential and must not be made public or copied, reproduced, or otherwise used without the express approval of J.C. Pardo & Sons. Any use, directly or indirectly in any way detrimental to J.C. Pardo & Sons.

SIZE: B

REV.

DRAWING NUMBER:  
8576

SHEET  
1 of 1

MAIN JUNCTION BOX (N)

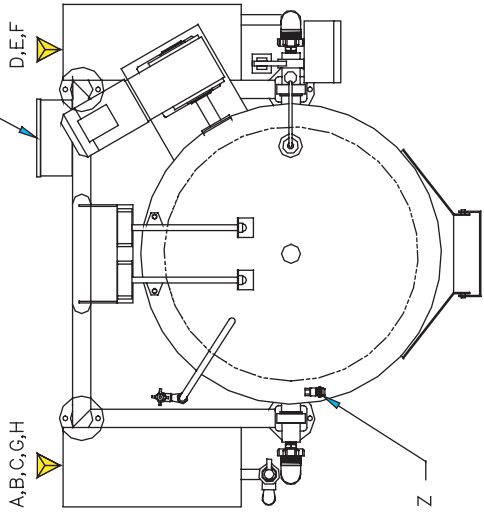

**WATER CONSERVATION OPTION:**  
 THE JACKET DRAIN LINE CAN DUMP INTO  
 THE COOLING WATER OUT LINE AS SHOWN  
 ABOVE.

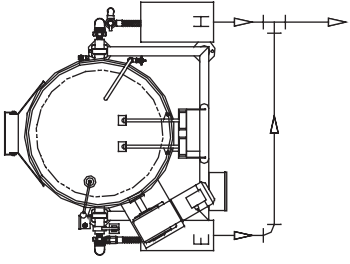

UTILITY CONNECTIONS

- A) 1 1/4" NPT STEAM IN
- B) 3/4" NPT COLD POTABLE WATER
- C) 3/4" NPT HOT POTABLE WATER (OPTIONAL)
- D) 1 1/4" NPT COOLING WATER IN
- E) 1 1/4" NPT JACKET DRAIN
- F) 1" NPT CONDENSATE RETURN
- G) 1/2" NPT AIR IN
- H) 1 1/4" NPT COOLING WATER OUT
- N) MOTOR & CONTROL POWER IN FROM MAIN CONTROL PANEL.
- Z) AIR CONNECTION FOR FOOD PUMP

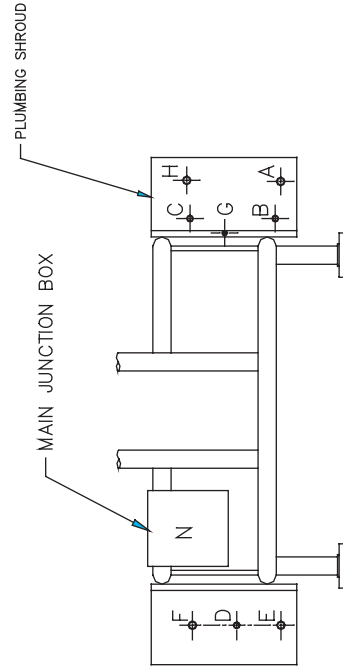
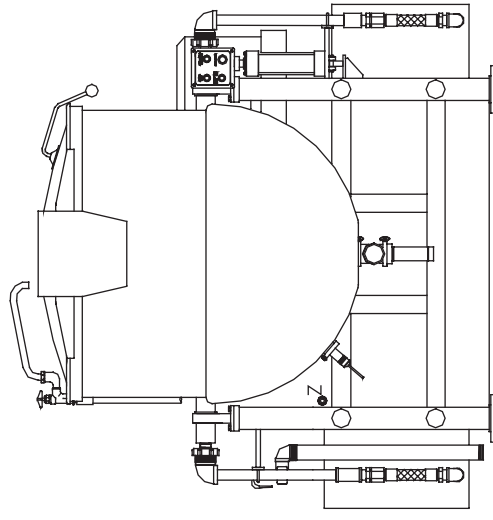

REAR DETAIL WITH UTILITY CONNECTIONS

**J.C.PARDO & SONS INC.**  
 1250 REAMES RD. BALTO MD. 21220  
 PHONE (410) 391-9000 FAX (410) 391-9042

REV.	DESCRIPTION	BY	DATE
REVISIONS			

CHECKED BY:	DATE: 2/27/03
APPROVED BY:	SCALE: NONE

HA-MKDL-150-CC-T (R.H.)  
UTILITY CONNECTIONS

DRAWING NUMBER:	SIZE:	REV.
9196-R	C	1 of 1

This drawing and all information contained therein is the property of J.C. Pardo & Sons, Inc. It is to be used for the specific project and is not to be used for any other project without the written consent of J.C. Pardo & Sons, Inc. It is loaned subject to return upon demand and is not to be used directly or indirectly in any way, determined by J.C. Pardo & Sons.

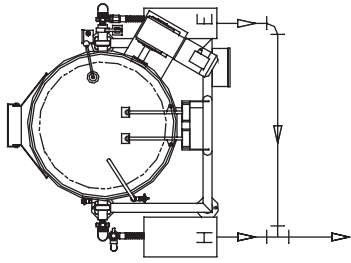

WATER CONSERVATION OPTION:  
THE JACKET DRAIN LINE CAN DUMP INTO  
THE COOLING WATER OUT LINE AS SHOWN  
ABOVE.

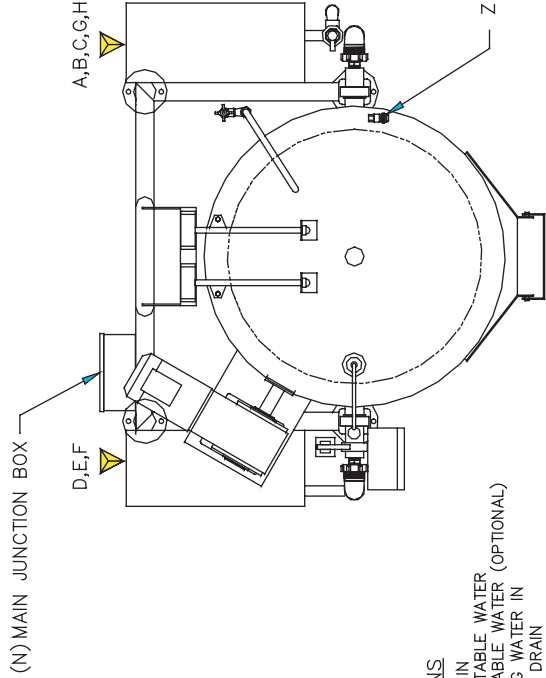

UTILITY CONNECTIONS

- A) 1 1/4" NPT STEAM IN
- B) 3/4" NPT COLD POTABLE WATER
- C) 3/4" NPT HOT POTABLE WATER (OPTIONAL)
- D) 1 1/4" NPT COOLING WATER IN
- E) 1 1/4" NPT JACKET DRAIN
- F) 1" NPT CONDENSATE RETURN
- G) 1/2" NPT AIR IN
- H) 1 1/4" NPT COOLING WATER OUT
- N) MOTOR & CONTROL POWER IN FROM MAIN CONTROL PANEL.
- Z) AIR CONNECTION FOR FOOD PUMP

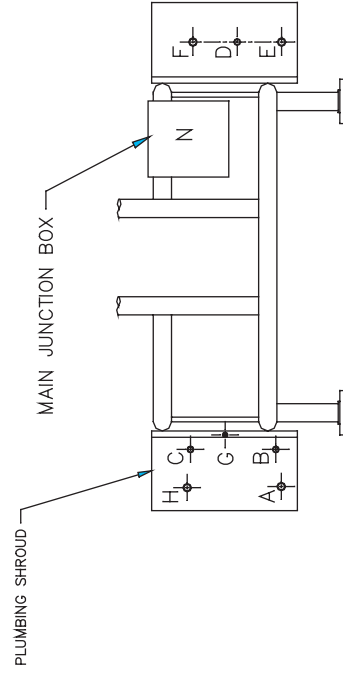

REAR DETAIL WITH UTILITY CONNECTIONS

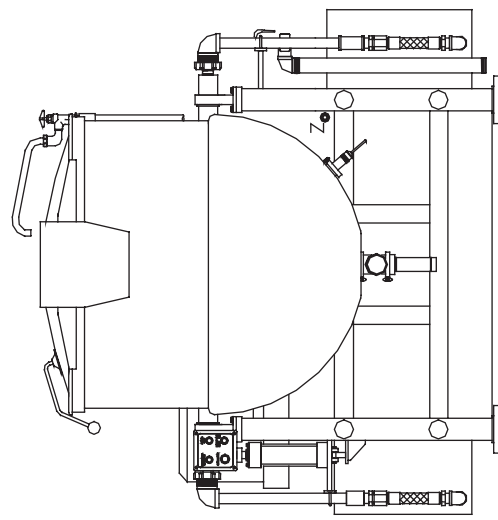

REV.	DESCRIPTION	BY	DATE	REVISIONS
<p><b>J.C.PARDO &amp; SONS INC.</b> 1250 REAMES RD. BALTO MD. 21220 PHONE (410) 391-3600 FAX (410) 391-9042</p>				<p>HA-MKDL-150-CC-T (L.H.) <b>UTILITY CONNECTIONS</b></p> <p><small>This drawing and all information contained therein is the property of J.C.Pardo &amp; Sons Inc. Balto, Md. The drawing and all information contained herein is not to be used or copied, in any way, without the written consent of J.C.Pardo &amp; Sons.</small></p>
<p>CHECKED BY: DRAWN BY: JAY S. DATE: 2/27/03 SCALE: NONE</p>				<p>SIZE: C REV: 1 of 1</p>
<p>DRINKING NUMBER: 9196-L</p>				

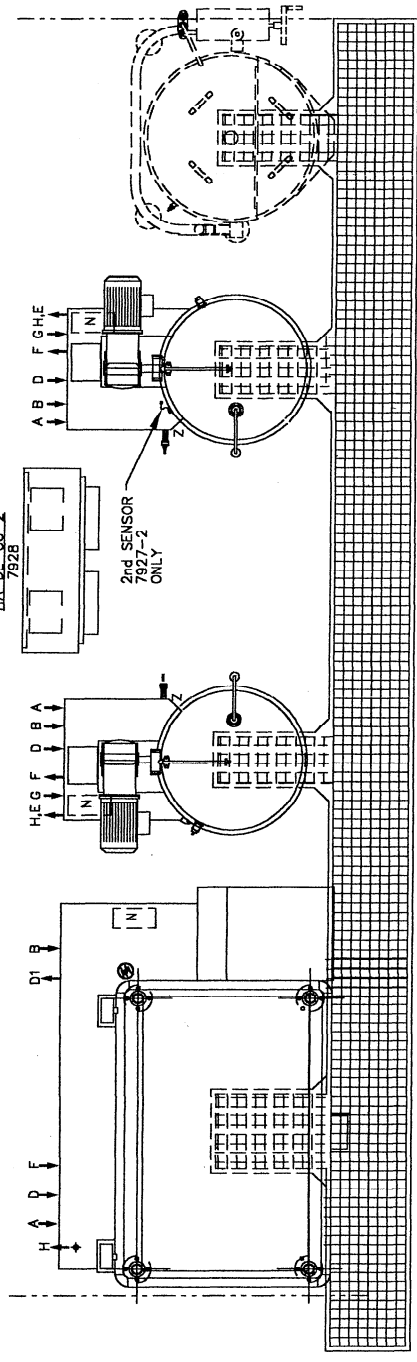

HA-DE-CC-2  
7926

2nd SENSOR  
7927-2  
ONLY

IC/CT-60-CC  
7926

HA-MKDL-60-CC  
7927-1

HA-MKDL-60-CC  
7927-2

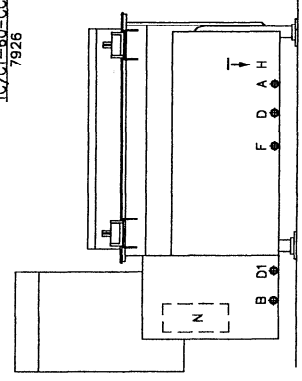

IC-CT-60-CC CONNECTIONS

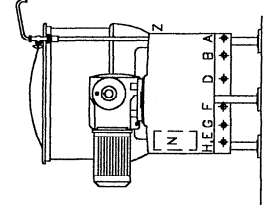

HA-MKDL-60-CC  
7927-2

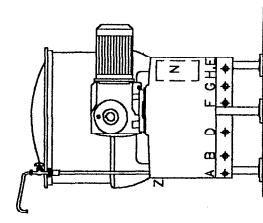

HA-MKDL-60-CC  
7927-1

**LEVELING INSTRUCTIONS**

DRIVE END OF TANK TO BE 3/4" LOWER THAN DISER END OF TANK. DO NOT UNSCREW FEET MORE THAN THE MAXIMUM SAFE ADJUSTMENT ALLOWED (REF. DWG. #9276) IF THIS IS NOT ENOUGH THEN USE SHIMS UNDER THE FEET.  
TANK MUST BE LEVEL FRONT TO BACK. USE THE LEVELING CENTER POINTS TO LEVEL FRONT TO BACK. IF LEVEL IS NOT POSSIBLE THEN BOTH SIDES SHOULD BE OUT OF LEVEL BY THE SAME AMOUNT AND IN THE SAME DIRECTION.

**UTILITY CONNECTIONS IC/CT-60-CC**

- A) 3/4" NPT STEAM IN
- B) 1/2" NPT COLD POTABLE FILL WATER
- D) 1/2" NPT COOLING WATER IN
- F) 3/4" NPT CONDENSATE RETURN
- H) 1/4" NPT COOLING WATER OUT
- N) 208V-3PH-60HZ MAIN POWER SUPPLY

**CUSTOMER CONNECTIONS**

- A) 3/4" NPT STEAM IN
- B) 1/2" NPT COLD POTABLE FILL WATER
- D) 3/4" NPT COOLING WATER IN
- F) 1/2" NPT CONDENSATE RETURN
- G) 1/2" NPT AIR IN
- H.E) 3/4" NPT COOLING WATER OUT & 3/4" NPT JACKET DRAIN
- N) CONTROL & POWER WIRES FROM MAIN CONTROL PANEL TO KETTLE.
- Z) AIR QUICK DISCONNECT FOR FOOD PUMP.

JOB#: \_\_\_\_\_ QTY: \_\_\_\_\_

**J.C.PARDO & SONS INC.**

**ISR-KENT  
UTILITY CONNECTIONS**

SIZE: **B**  
DRAWING NUMBER: **8983**

CHECKED BY:

APPROVED BY:

DATE: 7/25/00

SCALE: NONE

UNLESS NOTED OTHERWISE TOLERANCES ARE:  
XX = ±  
XXX = ±  
FRACT. = ±  
ANGLE = ±  
FINISH =

RMS

This drawing and all information contained therein is the property of J.C. Pardo & Sons Inc. No part of this drawing or information is confidential and must not be made public or copied. It is loaned subject to return upon demand and is not to be used directly or indirectly in any way detrimental to J.C. Pardo & Sons.

REV.

1 of 1  
SHEET

## MIXER KETTLES

### Kettle Placement

- Level
- Centered on hoist rail
- All legs bolted to floor
- Gear box properly supported
- Proper clearance
- Pasta basket and batch bucket clearances
- Floor drains and poor paths

### Electrical Requirements

- Voltage
- Phase
- Amp draw
- Wire Size
- Check motor rotation

### Water requirements

1. **Hot and cold water supply (Potable)**
  - Line size
  - Maximum water pressure
  - Line strainers
  - Pressure regulator
  - Water quality
2. **Chilled Water**
  - Line sizes (in and out)
  - Locate and inspect line strainer
  - Check for leaks

### Steam Requirements

- Locate steam source
- Line sizes (in and out)
- Steam pressure
- Steam gauge
- Check safety valve operation
- Check for leaks

### Air Requirements

- Line size
- Pressures
- Check lubricator
- Check for leaks

Model no. \_\_\_\_\_  
Serial no. \_\_\_\_\_

Comments:

## DAILY CLEANING INSTRUCTIONS OF AGITATOR ASSEMBLY

FOLLOW THE INSTRUCTIONS LISTED BELOW TO REMOVE THE AGITATOR:

- A. ROTATE THE AGITATOR UNTIL THE PULL PIN IS ON THE TOP SIDE.
- B. TURN POWER OFF TO AVOID ACCIDENTS.
- C. PULL PIN OUT. SLIDE COUPLING TOWARD SEAL AND CAREFULLY LIFT AGITATOR AND PULL BACK TO LIFT OUT. BY EXCEEDING TOO MUCH FORCE WHEN LIFTING THE AGITATOR UP, AND WITHOUT PULLING BACK, YOU WILL BEND THE IDLER BEARING SLEEVE WELDED IN THE INTERIOR OF THE KETTLE.

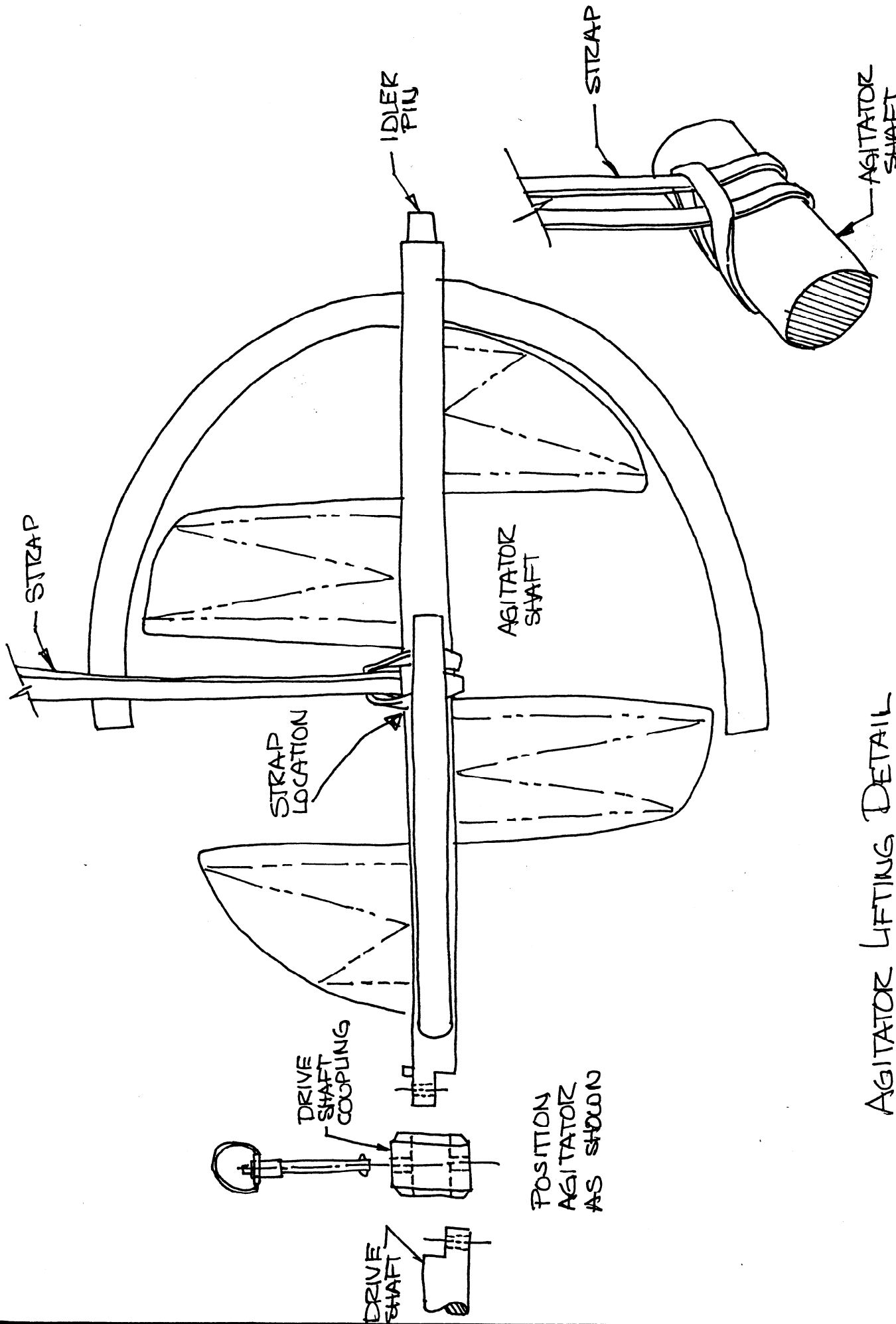

AGITATOR LIFTING DETAIL  
 LIFT GENTLY UNTIL IDLER PIN  
 COMES FREE FROM SOCKET.

DRAWING NO:

A-SK-0258

DATE:

12/28/94

BY:

JAY SCOTT

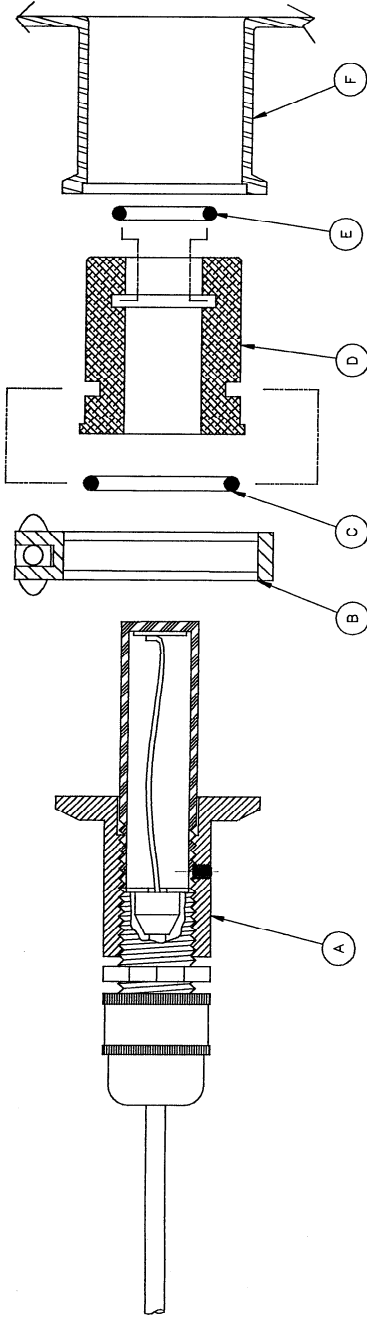

**CLEANING INSTRUCTIONS**

1. BE SURE KETTLE IS EMPTY AND MAIN POWER IS DISCONNECTED.
2. REMOVE CLAMP "B" AND SLIDE TEMP. PROBE ASSEMBLY "A" OUT OF THE SEAL HOLDER "D". PLACE PROBE ASSEMBLY IN HOLDER ON KETTLE LEG.
3. SLIDE SEAL HOLDER "D" OUT OF THE FERRULE "C" AND REMOVE INNER AND OUTER O-RINGS "C" AND "E".
4. CLEAN ALL PARTS THOROUGHLY.

**REASSEMBLY INSTRUCTIONS**

1. LUBRICATE O-RINGS WITH CHESTERTON 622, USDA APPROVED OR EQUIVALENT BEFORE REASSEMBLY.
2. INSTALL LUBRICATED O-RINGS "C" & "E" INTO SEAL HOLDER "D".
3. INSTALL SEAL HOLDER "D" WITH O-RINGS "C" & "E" INTO FERRULE "F".
4. SLIDE TEMP. PROBE ASSEMBLY "A" INTO SEAL HOLDER "D".
5. REPLACE CLAMP "B".

**WARNINGS**

1. FAILURE TO PLACE PROBE ASSEMBLY IN HOLDER COULD RESULT IN DAMAGE.
2. DO NOT USE CAUSTIC SODA ON PARTS "C", "D", OR "E" AS THIS WILL RESULT IN DAMAGE.

KETTLE LEG

TEMP SENSOR HOLDER

B	ADDED LINE NOTE 2	TJK	6/10/96
A	REDRAWN FROM HAND AND ADDED NOTES.	LY	4/27/95
REV	DESCRIPTION	BY	DATE
	REVISIONS		

**J.C.PARDO & SONS INC.**  
 1250 BEAMES RD.  
 BALTO MD. 21220  
 PHONE (410) 381-9800  
 FAX (410) 381-9042

DATE 4/27/95  
 DRAWN BY L.Y.  
 NONE

TEMPERATURE SENSOR  
 CLEANING INSTRUCTIONS  
 THIS DRAWING IS THE PROPERTY OF J.C.PARDO & SONS INC. IT IS TO BE USED ONLY FOR THE PURPOSES SPECIFIED HEREIN. IT IS NOT TO BE REPRODUCED OR TRANSMITTED IN ANY FORM OR BY ANY MEANS, ELECTRONIC OR MECHANICAL, INCLUDING PHOTOCOPYING, RECORDING, OR BY ANY INFORMATION STORAGE AND RETRIEVAL SYSTEM.

SIZE C  
 SHEET 8322  
 REV B  
 1 of 1

TO REMOVE TEFLON SCRAPER BLADE

INSERT TOOL THAT IS PROVIDED IN AREA INDICATED IN FIG. # 2. PULL UP ON SPRING ARM UNTIL SPRING ARM CLEARS GROOVE IN "PIN B". GENTLY RELEASE SPRING. SPRING IS NOW DISENGAGED, REMOVE SCRAPER.

TO INSTALL TEFLON SCRAPER BLADE

SLIDE SCRAPER BLADE AND SPRING ONTO "PIN A" AS SHOWN IN FIG. # 1 & FIG. # 2 USING TOOL THAT IS PROVIDED. HOOK SPRING ARM & PULL UP. SLIDE ASSEMBLY ON AND HOOK SPRING ARM IN GROOVE ON "PIN B" AND RELEASE.

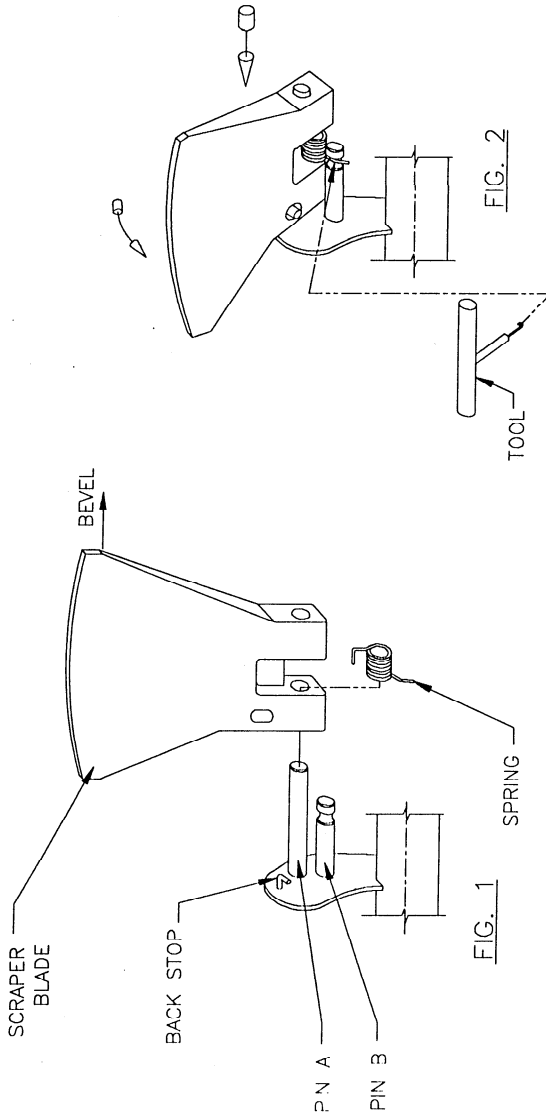

JOB #

**J. C. PARDO & SONS INC.**



1250 REAMES RD. BALTO. MD. 21220

SCALE: NONE

APPROVED BY:

DATE: 4/25/95

DRAWN BY: LAURIE YORI

REV. A

INSTALLATION & REMOVAL OF SCRAPER BLADE & SPRING

SHEET 1 of 1

DRAWING NUMBER: B 8059

THIS DRAWING AND ALL INFORMATION CONTAINED THEREIN IS THE PROPERTY OF J. C. PARDO & SONS INC. BALTO. MD.. THE DRAWING AND INFORMATION IS CONFIDENTIAL AND MUST NOT BE MADE PUBLIC OR COPIED. IT IS LOANED SUBJECT TO RETURN UPON DEMAND AND IS NOT TO BE USED DIRECTLY OR INDIRECTLY IN ANY WAY DETRIMENTAL TO THE INTERESTS OF J. C. PARDO & SONS INC.

INSTALLATION OF NEW SCRAPER BLADE

WHEN INSTALLING A NEW SCRAPER BLADE THERE MAY BE SOME ADJUSTMENTS REQUIRED TO MAKE IT LAY FLAT TO FOLLOW THE CONTOUR OF THE KETTLE. IF THE BLADE DOES NOT FIT, YOU MAY HAVE TO GRIND EITHER THE TWO EDGES OF THE BLADE, OR THE CENTER OF THE BLADE (PER. DETAIL A).

NOTE # 1

WHEN THERE IS TOO MUCH OR TOO LITTLE PRESSURE ON THE SCRAPER BLADE, BEND THE BACK STOP DOWN TO DECREASE THE PRESSURE OR BEND IT UP TO INCREASE THE PRESSURE ON THE BLADE WHEN SCRAPING THE KETTLE SURFACE (PER. FIG. 1).

NOTE # 2

IF ONLY ONE CORNER OF THE SCRAPER BLADE IS TOUCHING THE KETTLE SURFACE, USE A CRESCENT WRENCH AND SLIGHTLY TWIST THE SCRAPER HOLDER SO THE ENTIRE BLADE SCRAPES THE KETTLE WALL WITH EVEN PRESSURE.

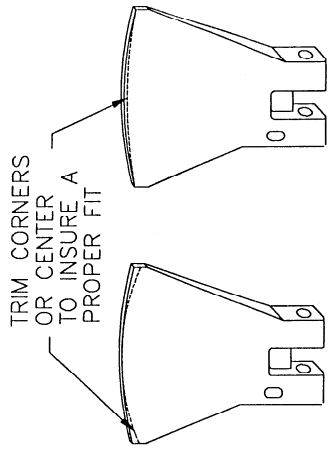
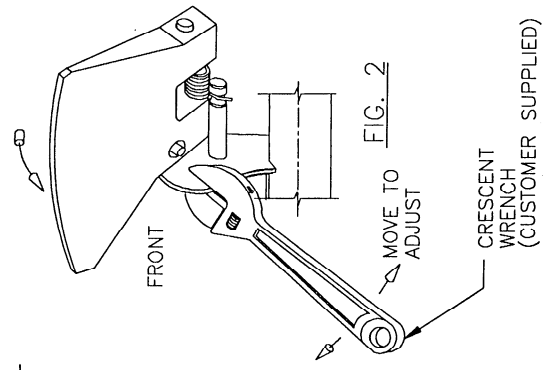
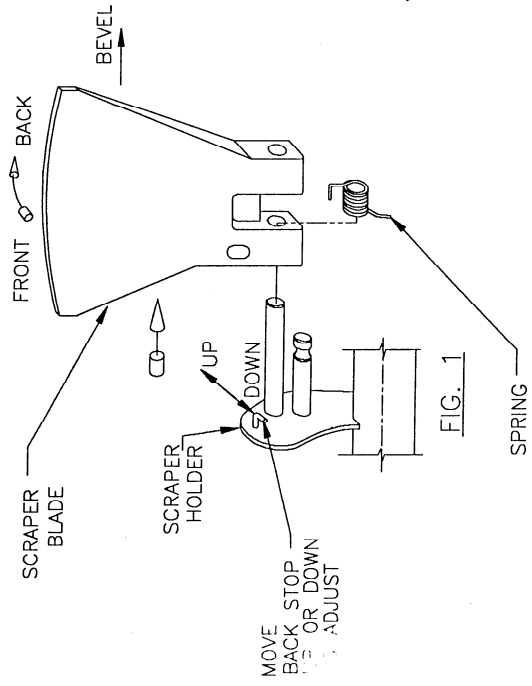

DETAIL A

JOB #

<b>J.C.PARDO &amp; SONS INC.</b>		BALTO. MD. 21220
1250 REAMES RD.		
SCALE: NONE	APPROVED BY: <i>Jul G</i>	DATE: 4/25/95
DRAWN BY: LAURIE YORI		
REPLACEMENT AND FITTING SCRAPER BLADE & SPRING		
SHEET 1 of 1	SIZE: B	DRAWING NUMBER: 8230
		REV. C

THIS DRAWING AND ALL INFORMATION CONTAINED THEREIN IS THE PROPERTY OF J. C. PARDO & SONS INC. BALTO. MD. THE DRAWING AND INFORMATION IS CONFIDENTIAL AND MUST NOT BE MADE PUBLIC OR COPIED. IT IS LOANED SUBJECT TO RETURN UPON DEMAND AND IS NOT TO BE USED DIRECTLY OR INDIRECTLY IN ANY WAY DETRIMENTAL TO THE INTERESTS OF J. C. PARDO & SONS INC.

**INSTRUCTIONS:**

1. DISCONNECT THE AIR LINE FROM THE VALVE ACTUATOR AS SHOWN IN FIGURE 1.
2. WHILE SUPPORTING THE VALVE ACTUATOR REMOVE THE BOTTOM CLAMP FROM THE TEE, THEN LOWER THE VALVE ACTUATOR AND SWING IT TO THE SIDE UNTIL THE STEM IS CLEAR OF THE TEE AS SHOWN IN FIGURE 1. GENTLY LOWER VALVE ACTUATOR TO THE FLOOR AS SHOWN IN FIGURE 2.
3. REMOVE THE STEM FROM THE VALVE ACTUATOR BY PULLING UP WHILE HOLDING THE VALVE ACTUATOR IN PLACE AS SHOWN IN FIGURE 2. NEXT REMOVE THE O-RING FROM THE ACTUATOR & STEM AS SHOWN IN FIGURE 2.
4. REMOVE THE TOP CLAMP FROM THE TEE AND THEN REMOVE THE TEE AS SHOWN IN FIGURE 3.
5. REMOVE THE O-RINGS FROM THE TEE AS SHOWN IN FIGURE 4.

SEE DRAWING C-86300 FOR ASSEMBLY INSTRUCTIONS.

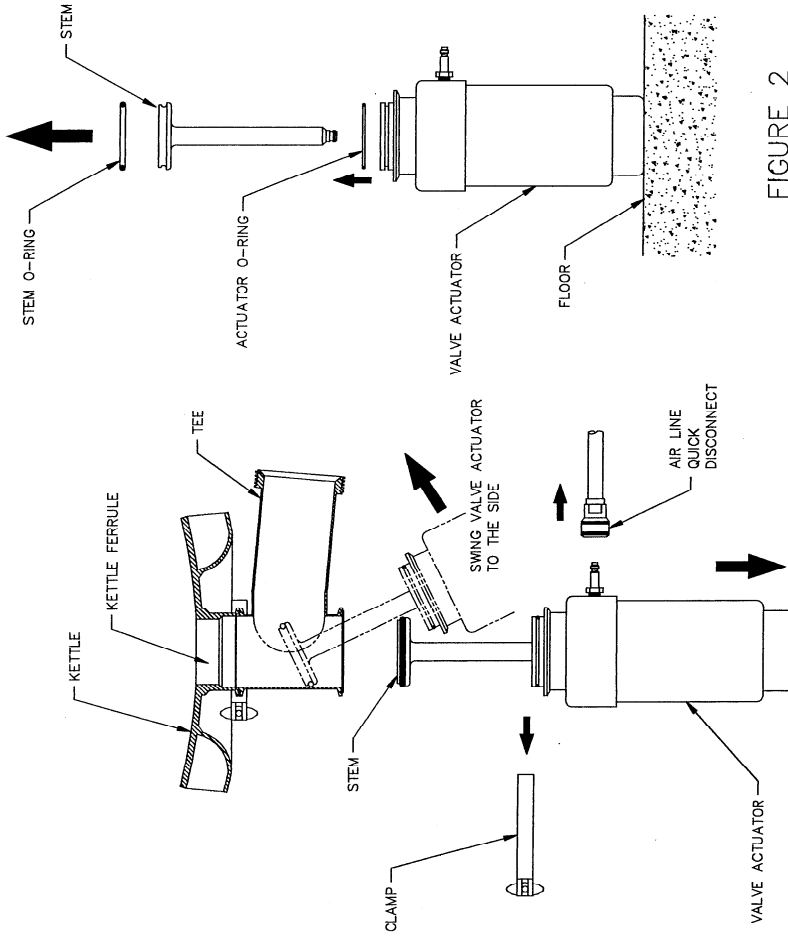

FIGURE 1

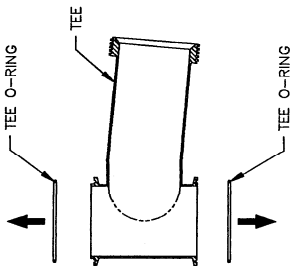

FIGURE 2

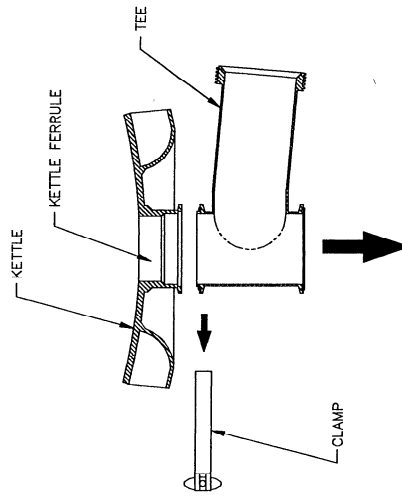

FIGURE 3

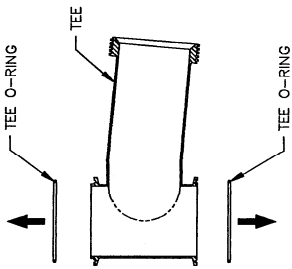

FIGURE 4

REV. A	7" CONN WAS 45"	JES	4-27-96
	DESCRIPTION	BY	DATE
REVISIONS			

**J.C. PARDO & SONS INC.**  
 1250 REAMES RD.  
 BALTO MD. 21220  
 PHONE (410) 391-8800  
 FAX (410) 391-9042

ORDERED BY: JAY S.  
 DATE: 4-19-96  
 APPROVED BY: [Signature]

**INSTRUCTIONS TO DISASSEMBLE  
 3" PRODUCT VALVE W/NEW STEM**

REV. C  
 DRAWING NUMBER: 8629  
 SHEET: 1 of 1

The drawing and all information contained therein is the property of J.C. Pardo & Sons, Inc. and must not be reproduced, copied, sold, or otherwise disseminated in any way determined by J.C. Pardo & Sons.

**INSTRUCTIONS:**

1. MAKE SURE CONTROL POWER IS ON.
2. CLEAN AND GREASE STEM AND O-RINGS. USE CHESTERION 622 OR EQUAL FOOD GRADE GREASE.
3. TO ASSEMBLE VALVE ACTUATOR AND STEM:
  - A) PLACE VALVE ACTUATOR ON THE FLOOR AND RECONNECT THE AIR LINE.
  - B) PLACE STEM IN THE VALVE ACTUATOR AS SHOWN IN FIGURE 1.
  - C) APPLY PRESSURE TO THE TOP OF THE STEM AS SHOWN IN FIGURE 1.

**CAUTION:** USE THE FLAT OF THE HAND AS SHOWN IN FIGURE 1. FAILURE TO FOLLOW THIS MAY RESULT IN PERSONAL INJURY.

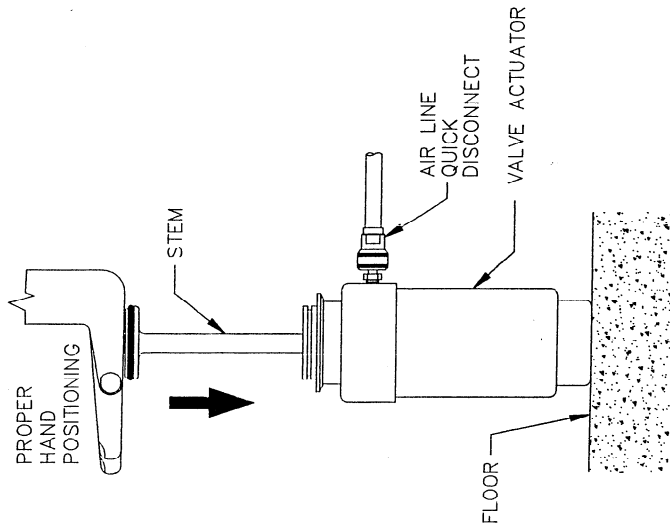

FIGURE 1

**INSTRUCTIONS (CONT):**

- D) WHILE APPLYING PRESSURE TO THE STEM TURN THE PRODUCT VALVE SWITCH TO THE OPEN POSITION. THE STEM SHOULD LOWER.
 

**NOTE:** IF THE STEM FAILS TO LOWER MAKE SURE THE STEM IS INSERTED CORRECTLY INTO THE VALVE ACTUATOR THEN REPEAT STEPS 3B THRU 3D.
4. ATTACH THE TEE TO THE KETTLE FERRULE WITH CLAMP AS SHOWN IN FIGURE 2.
5. ATTACH THE VALVE ACTUATOR TO THE TEE WITH CLAMP AS SHOWN IN FIGURE 3.
6. TURN THE PRODUCT VALVE SWITCH TO THE CLOSED POSITION AND THE KETTLE VALVE WILL CLOSE.

**NOTE:**

A. FOR INSTRUCTIONS TO DISASSEMBLE VALVE SEE DRAWING C-8629.

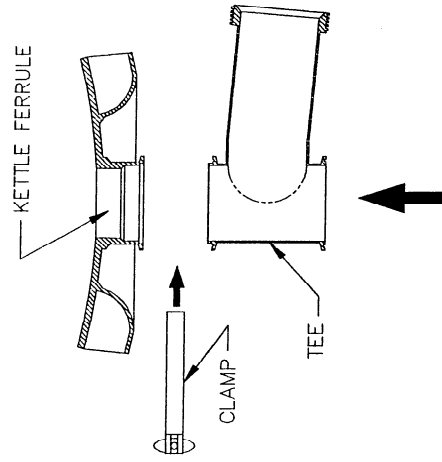

FIGURE 2

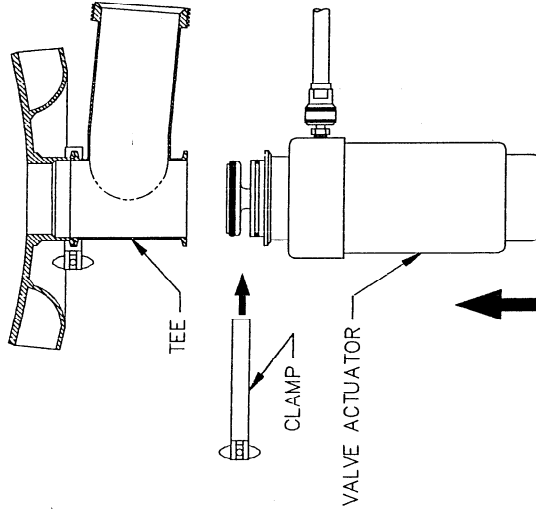

FIGURE 3

REV.	DESCRIPTION	BY	DATE
A	7" TEE CONN WAS 45°	JES	4-27-96

**REVISIONS**

**J.C.PARDO & SONS INC.**  
 1250 REAMES RD.  
 BALTO MD. 21220  
 PHONE (410) 891-9600  
 FAX (410) 891-6042

DESIGNED BY: **WLG**  
 APPROVED BY: **WLG**  
 DATE: 4/19/96  
 SCALE: NONE

**INSTRUCTIONS TO REASSEMBLE  
 3" PRODUCT VALVE W/NEW STEM**

DATE: 8/6/96  
 SIZE: C  
 DRAWING NUMBER: 8630  
 REV: A  
 SHEET: 1 of 1

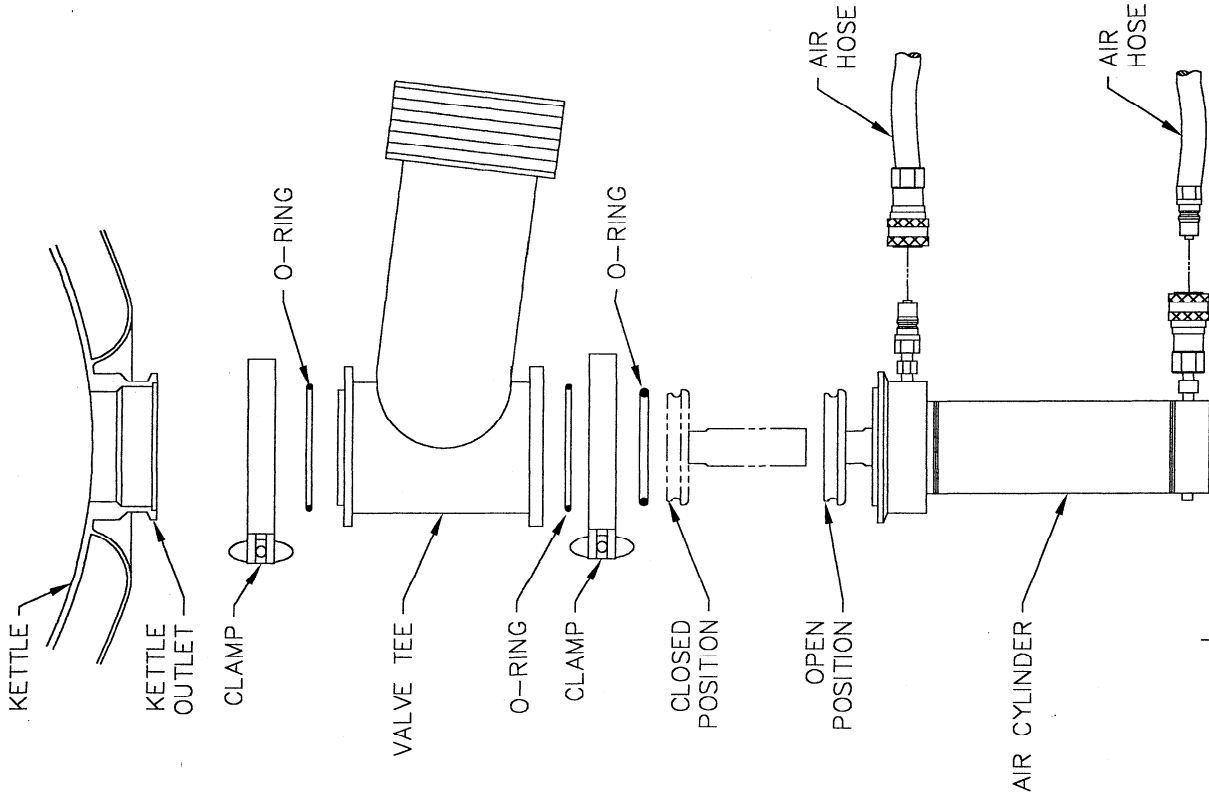

**J.C.PARDO INSTALLATION & CLEANING  
INSTRUCTION FOR PRODUCT VALVE**

- 1.) OPEN PRODUCT VALVE.
- 2.) DISCONNECT AIR HOSES.
- 3.) REMOVE AIR CYLINDER.
- 4.) REMOVE VALVE TEE.
- 5.) REMOVE ALL O-RINGS.
- 6.) CLEAN AIR CYLINDER, **DO NOT** SUBMERGE IN WATER. WIPE CLEAN AND SANITIZE.
- 7.) CLEAN AND SANITIZE TEE AND O-RINGS.
- 8.) GREASE AND REINSTALL O-RINGS.
- 9.) REINSTALL TEE TO KETTLE OUTLET.
- 10.) REINSTALL AIR CYLINDER TO BOTTOM OF TEE.
- 11.) RECONNECT AIR HOSES.
- 12.) O.K. TO CLOSE VALVE AND CHECK FOR ALIGNMENT.

**J.C.PARDO & SONS INC.**  
 1250 BEAVERS RD.  
 PEARLE (410) 261-3000

3" J.C.PARDO PRODUCT VALVE  
 CLEANING INSTRUCTION

DATE BY  
 01/09/01  
 APPROVED BY  
 JMC-NDE

9027  
 1 of 1

REVI	DESCRIPTION	BY	DATE
	REVISIONS		

DAILY CLEANING :

1. REMOVE RETAINING KNOBS.
2. SLIDE SHAFT SEAL RETAINER PLATE AWAY FROM SHAFT HOUSING.
3. SLIDE QUAD RING AWAY FROM SHAFT HOUSING.
4. CLEAN QUAD RING AND APPLY A LIGHT COAT OF 622 CHESTERTON WHITE FOOD GRADE GREASE OR EQUIVALENT.
5. SLIDE QUAD RING TOWARDS SHAFT HOUSING MAKING SURE THE QUAD RING DOES NOT TWIST.
6. SLIDE PLATE TOWARDS SHAFT HOUSING.
7. REPLACE RETAINING KNOBS.  
HAND TIGHTEN ONLY.

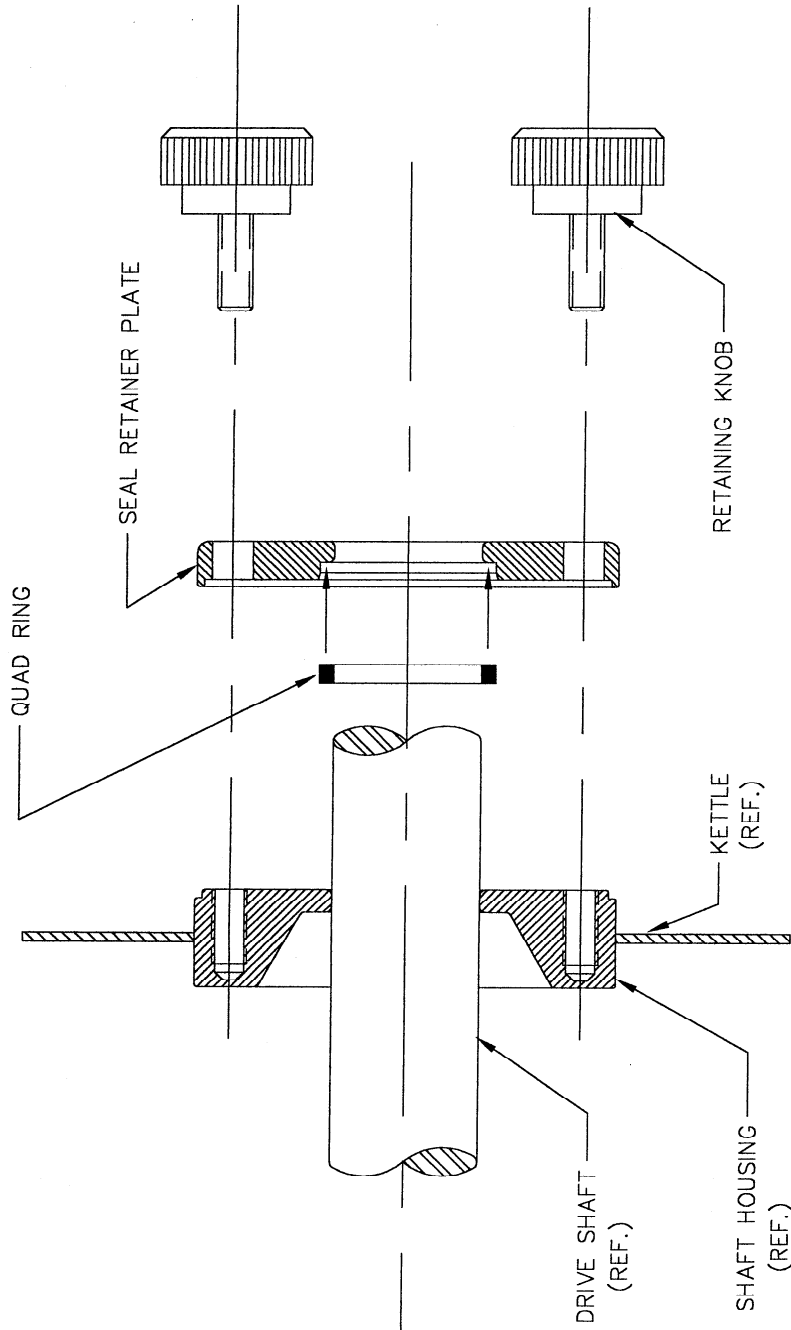

**J.C.PARDO & SONS INC.**  
 1250 REAMES RD.  BALTO. MD. 21220

SCALE: NONE	APPROVED BY:	DRAWN BY:
DATE: 3-23-94		TIM KAHL
SHAFT SEAL AND RETAINER PLATE		
DAILY CLEANING PROCEDURE		
SIZE: B	DRAWING NUMBER:	REV.
	8516	

THIS DRAWING AND ALL INFORMATION CONTAINED THEREIN IS THE PROPERTY OF J.C. PARDO & SONS INC. BALTO. MD. IT IS LOANED TO YOU FOR YOUR USE ONLY AND MUST NOT BE MADE PUBLIC OR COPIED. IT IS LOANED SUBJECT TO RETURN UPON DEMAND AND IS NOT TO BE USED DIRECTLY OR INDIRECTLY IN ANY WAY DETRIMENTAL TO THE INTERESTS OF J. C. PARDO & SONS INC.

## **ASSEMBLY AND REMOVAL OF 300 GALLON HORIZONTAL AGITATOR KETTLE**

### **CLEANING OR MAINTENANCE**

1. ROTATE AGITATOR UNTIL PULL PIN IS ON THE TOP SIDE.
2. TURN POWER **OFF** TO AVOID ACCIDENTS.
3. REMOVE KETTLE COVER.
4. SECURE LIFTING STRAP TO THE CENTER OF AGITATOR SHAFT AS SHOWN ON DWG. #8680 HOLD SO IT DOES NOT DROP.
5. REMOVE PULL PIN #8, SLIDE COUPLING ALL THE WAY TOWARD SEAL TO CLEAR AGITATOR SHAFT.
6. REMOVE BOLTS #12. GENTLY PULL BACK ON BEARING BLOCK #3 BY HOLDING THE HANDLE ON TOP SIDE OF BEARING BLOCK. **DO NOT DROP**
7. WITH ONE HAND OPERATE HOIST SWITCH, USING OTHER HAND TO GUIDE AGITATOR OUT OF THE KETTLE AND SET IT ON THE AGITATOR DOLLY.

### **REINSTALL THE AGITATOR**

1. LOWER THE AGITATOR WITH A HOIST, GENTLY SET BUSHING SIDE ON THE AGITATOR REST AND THE OTHER END ON THE DRIVE SHAFT, SIDE WITH COUPLING.
2. SLIDE COUPLING IN PLACE THEN INSERT PULL PIN.
3. GENTLY SLIDE IDLER BEARING BLOCK INTO KETTLE HUB. SECURE WITH THE (4) BOLTS, GREASE BUSHING, REMOVE STRAP, AND REPLACE KETTLE COVER.  
**(ASSEMBLY IS COMPLETE)**

## CLEANING OF A 300 GALLON HORIZONTAL AGITATOR IDLER END BEARING

HERE ARE TWO WAYS OF CLEANING A 300 GAL. HORIZ. AGI. IDLER END BEARING:

1. THE FIRST WAY IS TO FLUSH IT OUT WITH HOT WATER OR STEAM.
2. THE SECOND WAY IS TO REMOVE THE IDLER BEARING SECTIONS COMPLETELY.

### TO CLEAN WITH HOT WATER OR STEAM

1. SET AGITATOR SPEED TO LOWEST SETTING THEN TURN ON AGITATOR.  
(MAKE SURE KETTLE COVER IS CLOSED)
2. TURN ON VALVE TO STEAM OR HOT WATER THAT GOES TO THE CONNECTION OF AGITATOR IDLER BEARING MARKED **FLUSH CONNECTION** ON DWG. #8680. LEAVE ON FOR 5 TO 10 MINUTES THEN TURN OFF HOT WATER OR STEAM VALVE.
3. STOP AGITATOR, OPEN KETTLE COVER, AND RINSE INSIDE OF KETTLE WITH HOT WATER HOSE.
4. USING A GREASE GUN, GREASE IDLER BEARING WITH A CHESTERTON FOOD GREASE 622 OR EQUAL.
5. CLEAN DRIVE SIDE SHAFT SEAL. FOLLOW INSTRUCTIONS ON DWG. #8516.

### TO CLEAN BY REMOVING THE BEARING SECTIONS

1. TURN POWER OFF TO THE KETTLE.
2. REMOVE BOLTS #13.
3. REMOVE BEARING END CAP, PART #1.
4. REMOVE BOLTS #12.
5. REMOVE BEARING BLOCK, PART #3 (**DO NOT DROP**). THE AGITATOR SHAFT WILL REST ON THE AGITATOR REST INSIDE THE KETTLE, AS ALL OF THIS IS SHOWN ON DWG. #8680.
6. REMOVE O-RING #2 AND #4 FROM PART #1 AND 3.
7. CLEAN THE END OF THE AGITATOR SHAFT AND ALL OTHER PARTS OF SEAL HOUSING WITH ANY ACCEPTABLE CLEANING SOLUTION, USING A CLOTH OR BRUSH.
8. APPLY A THIN COAT OF CHESTERTON 622 FOOD GREASE OR EQUAL TO THE OUTSIDE OF THE AGITATOR SLEEVE AND INSIDE THE BEARING HOUSING.
9. APPLY A THIN COAT OF GREASE ON O-RING #4 AND SLIDE BACK ONTO PART #3.

10. GENTLY SLIDE BEARING BLOCK BACK INTO KETTLE HUB TO START BOLTS. START BOLTS AND TIGHTEN SUFFICIENTLY TO HOLD THE AGITATOR BEARING BLOCK FROM MOVING AND LEAKING.
11. GREASE O-RING #1 THEN INSERT ONTO END CAP, PART #1.
12. INSERT CAP #1 INTO BEARING BLOCK AND BOLT IN PLACE SO IT DOESN'T LEAK.
13. FOLLOW DWG. #8516, AND CLEAN DRIVE SIDE SHAFT SEAL.

DRAWINGS FOR REPLACEMENT PARTS

ITEM	DRAWING NO.	DESCRIPTION
1	SE39R000005	QUAD RING
2	FAS04-5000001	SEAL RETAINER PLATE
3	HWS00-3800003	RETAINING KNOBS

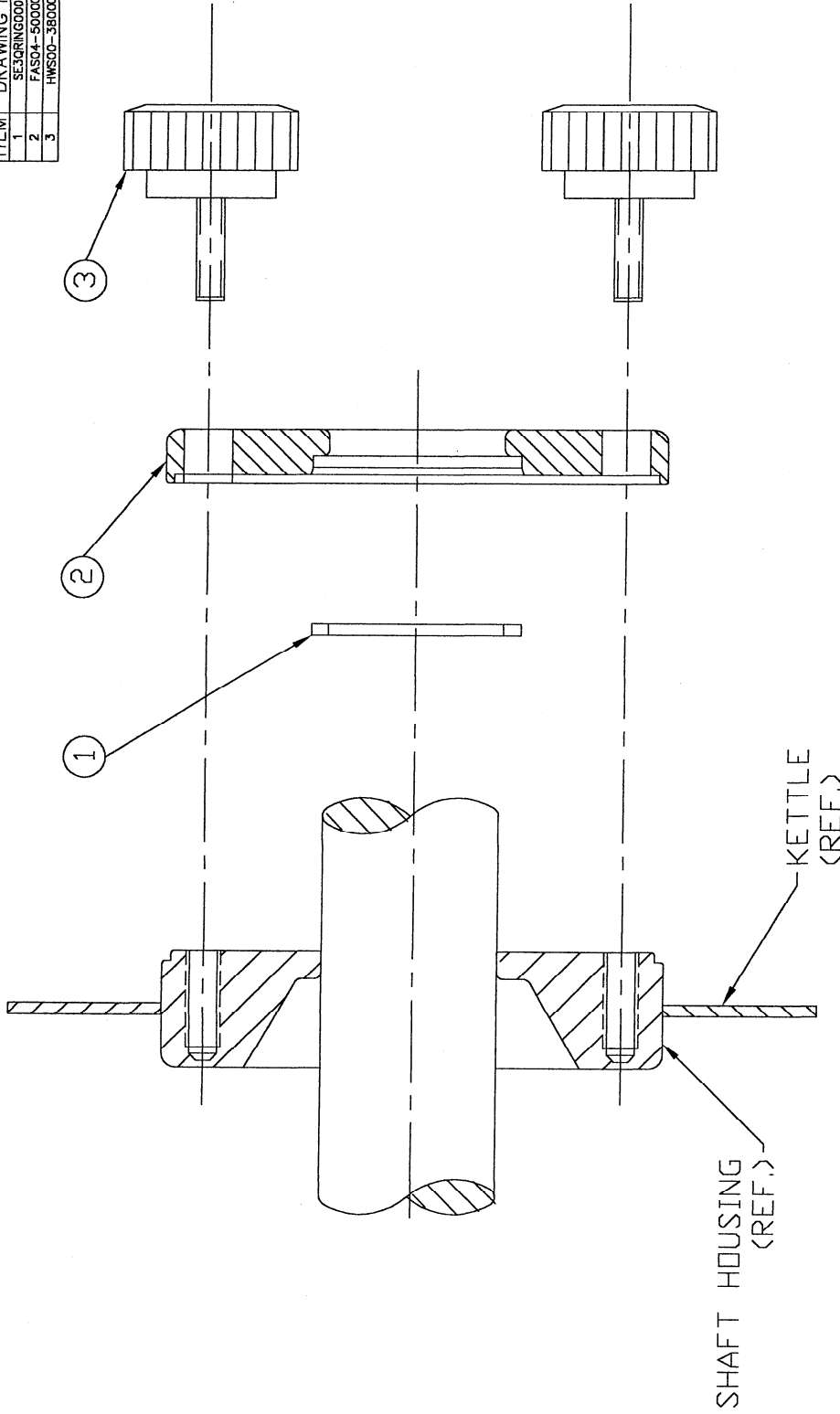

A	REDRAWN IN ACAD	SME	8-27-99
REV	DESCRIPTION	BY	DATE

**J.C.PARDO & SONS INC.**

CHECKED BY: \_\_\_\_\_ APPROVED BY: \_\_\_\_\_

JOB#: \_\_\_\_\_ QTY: \_\_\_\_\_

UNLESS NOTED OTHERWISE TOLERANCES ARE: XX = ±XXX XXX = ±XXXX FRACT. = ±XXXX ANGLE = ±XXXX FINISH=64 RMS	DRAWN BY: SME DATE: 8-27-99 SCALE: NONE	SHAFT SEAL AND RETAINER PLATE PARTS FOR 60 GAL	SIZE: B	DRAWING NUMBER: 11023
This drawing and all information contained therein is the property of J.C.Pardo & Sons, Inc. and must not be made public or copied. It is loaned subject to return upon demand and is not to be used directly or indirectly in any way detrimental to J.C.Pardo & Sons.		REV. A	SHEET	1 of 1



# REPLACEMENT PARTS LIST

ITEM	PART NO.	DESCRIPTION
1	SE3QRING00001	QUAD RING
2	1FS05-0000002	COVER PLATE
3	1HS00-3800001	RETAINING KNOB

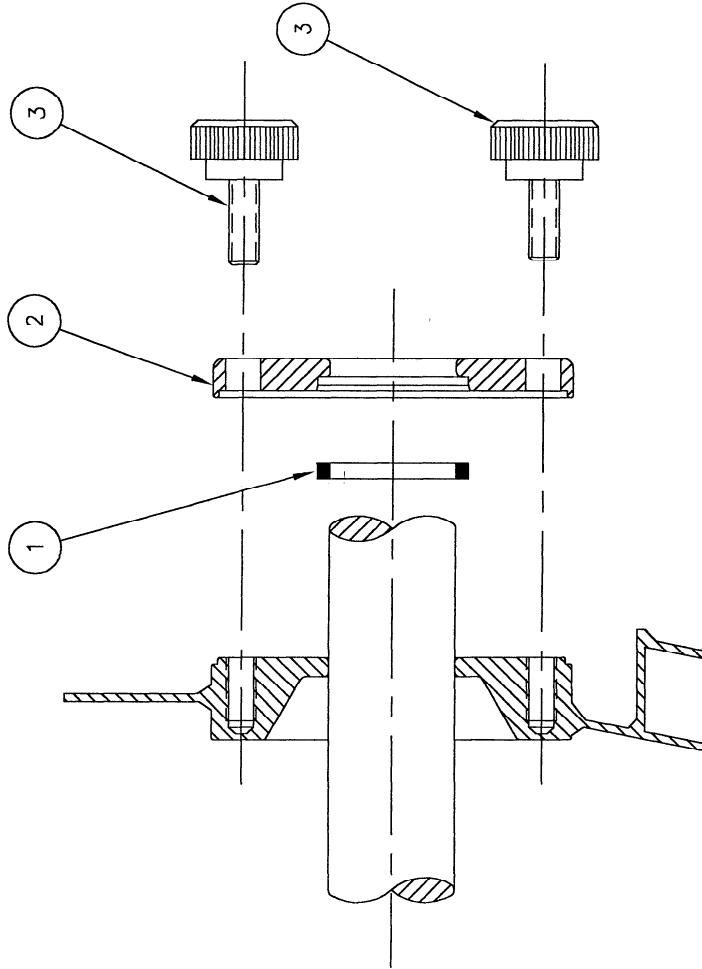

**J.C. PARDO & SONS INC.**  
 1250 REAMES RD.  
 BALTO MD. 21220  
 PHONE (410) 391-3600  
 FAX (410) 391-9042

CHECKED BY:  
**JES**

APPROVED BY:

DRAWN BY: **JAY S.**

DATE: **2-23-94**

SCALE: **NONE**

**SHAFT SEAL AND RETAINER PLATE  
 100,150 & 200 GAL REPL. PARTS**

SIZE: **B**

REV: **A**

DRAWING NUMBER:  
**8518**

SHEET  
**1 of 1**

This drawing and all information contained therein is the property of J.C. Pardo & Sons Inc. Balto MD. The drawing and all information is confidential and must not be made public or copied. It is loaned subject to return upon demand and not to be used directly or indirectly in any way detrimental to J.C. Pardo & Sons.

# REPLACEMENT PARTS LIST

ITEM	PART NO.	DESCRIPTION
1	1FS02-7500005	DRIVE SHAFT
2	SE3QRING00002	QUAD RING
3	1FS05-7500001	COVER PLATE
4	HWS00-3800003	RETAINING KNOB

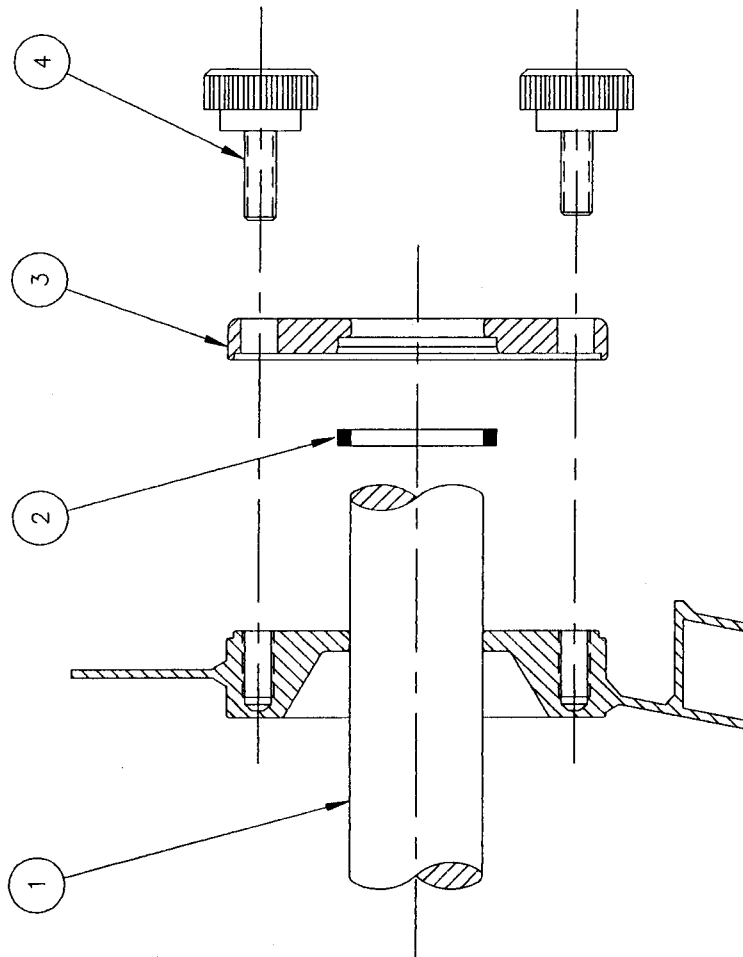

**J.C. PARDO & SONS INC.**  
 1250 REAMES RD. BALTO MD. 21220  
 PHONE (410) 391-3600 FAX (410) 391-9042

CHECKED BY: \_\_\_\_\_  
 APPROVED BY: *V6 4/8/96*

DRAWN BY: JAY S.  
 DATE: 4-3-96  
 SCALE: NONE

SHAFT SEAL AND RETAINER PLATE  
 300 GAL REPLACEMENT PARTS

This drawing and all information contained therein is the property of J.C. Pardo & Sons Inc. Balto MD. The drawing and all information contained herein must not be made public or copied, reproduced, or transmitted in any form or by any means, directly or indirectly in any way detrimental to J.C. Pardo & Sons.

SIZE: B  
 REV: \_\_\_\_\_  
 DRAWING NUMBER: 11185  
 SHEET: 1 of 1

# REPLACEMENT PARTS LIST

ITEM	PART NO.	DESCRIPTION
1	MSW00-7500001	SCRAPER BLADE
2	MSSPRING00002	SCRAPER BLADE SPRING
3	TOSPRING00001	SPRING REMOVAL TOOL

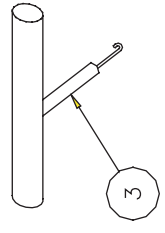
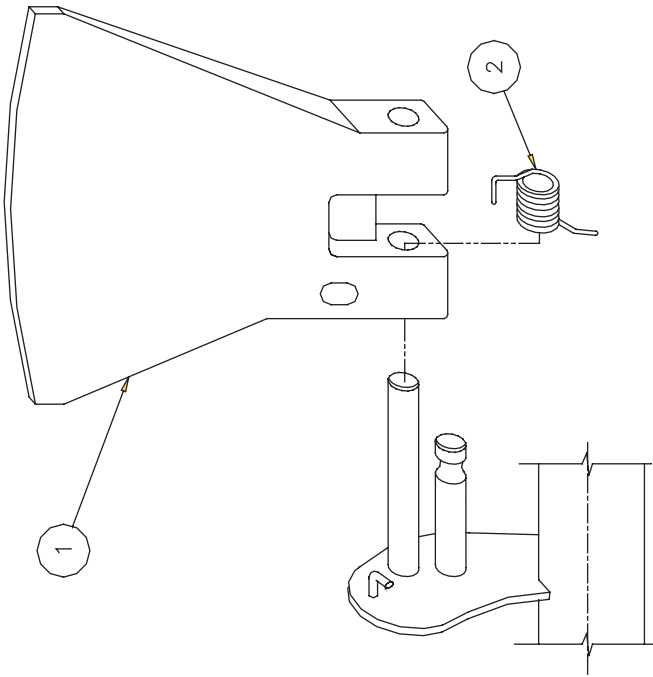

D	#1 WAS MSW00-8800001	JES	4-24-98
C	#1 WAS 1PW00-7500001	JES	1-6-98
B	REDRAWN FROM PAPER	LY	4/25/95
A	ITEM #1 WAS PART NO. MSFBLADE00001 WAS TEFLON NOW UHMP.	LY	3/22/95
REV.	DESCRIPTION	BY	DATE

## REVISIONS

DRAWN BY <b>L. YORI</b>	SIZE	DRAWING NUMBER
DATE 4/25/95	B	8412
SCALE NONE	REV. D	SHEET 1 of 1

**SCRAPER BLADE ASSEMBLY**  
**REPLACEMENT PARTS**

This drawing and all information contained therein is the property of J.C.Pardo & Sons, Inc., Balto, MD. The drawing and all information is confidential and must not be made public or copied. It is loaned subject to return upon demand and is not to be used directly or indirectly in any way detrimental to J.C.Pardo & Sons.

**J.C.PARDO & SONS INC.**

1250 REAMES RD.  
BALTO MD. 21220  
PHONE (410) 391-3600  
FAX (410) 391-9042



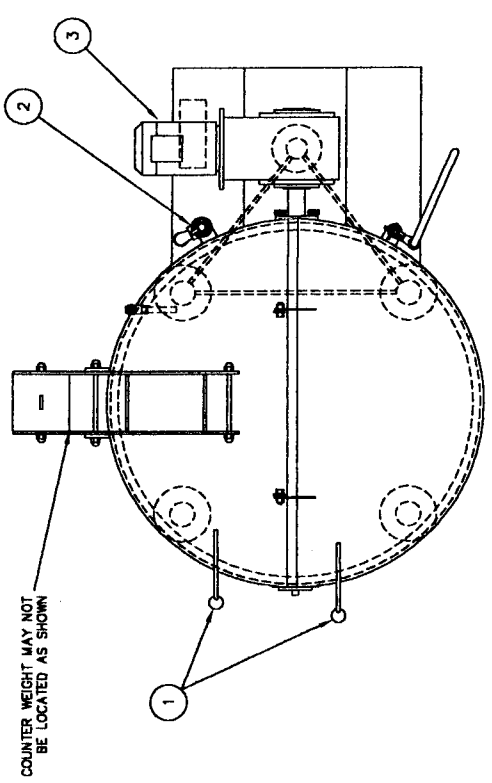

COUNTER WEIGHT MAY NOT BE LOCATED AS SHOWN

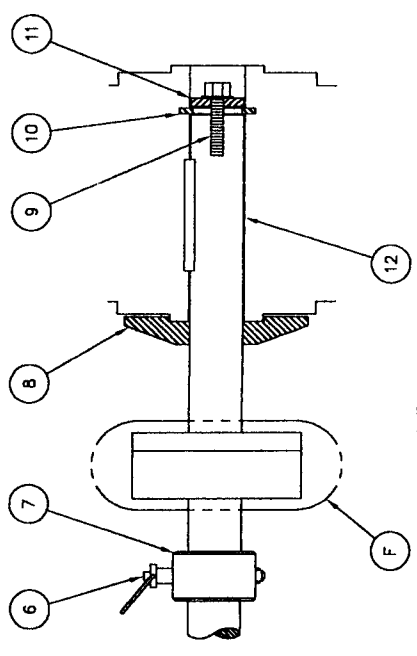

DETAIL Y

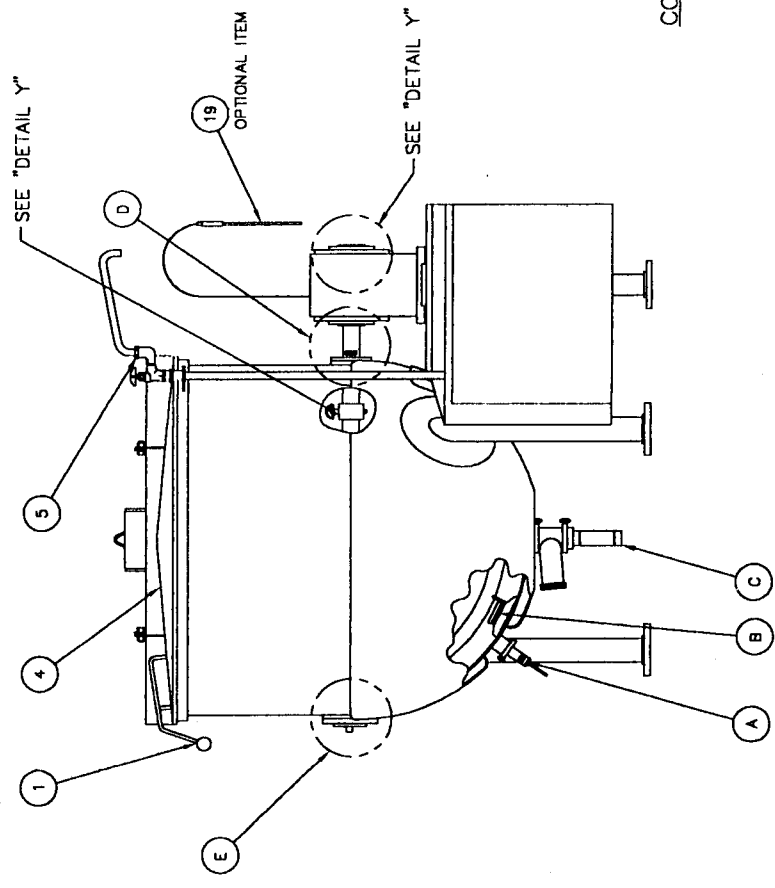

SEE "DETAIL Y"

SEE "DETAIL Y"

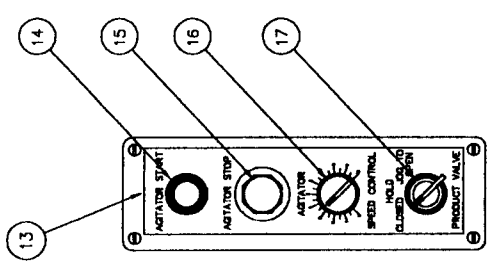

CONTROL STATION DETAIL

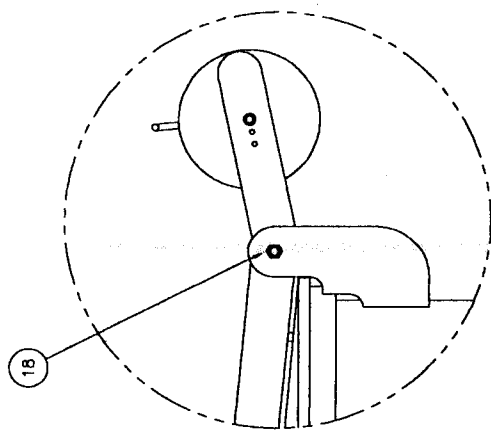

COUNTER WEIGHT DETAIL

REV. DESCRIPTION		BY DATE	<b>J.C. PARDO &amp; SONS INC.</b> 1250 REAMES RD. BALTO MD. 21220 PHONE (410) 391-3600		ORDER BY APPROVED BY	DRAWN BY JES DATE 4/1/02 SEAL NONE	HA-MKDL-300-CC <b>REPLACEMENT PARTS</b>	ORDER NUMBER 11657
REVISIONS								SHEET C
			1250 REAMES RD. BALTO MD. 21220 PHONE (410) 391-3600					SHEET 1 of 2

This drawing and all information contained herein is the property of J.C. Pardo & Sons, Inc. and is not to be distributed or used in any way without the written consent of J.C. Pardo & Sons, Inc. It is intended subject to patent when applicable and not to be used directly or indirectly in any way detrimental to J.C. Pardo & Sons.

ITEM	PART NO.	DESCRIPTION
1	MSP02-0000001	RED BALL
2	VAB01-2500001	100 PSI SAFETY VALVE
3	DUH05-0000009	5 HP DRIVE UNIT 208 VOLTS
-	DU905-0000005	ELECTRIC MOTOR 208 VOLTS
-	DU902-7500003	GEAR BOX
4	1V300GAL00004	SPLIT COVER W/COUNTER WEIGHT MNTS
5	PBB00-7500018	FILL FAUCET
6	MSS00-5000002	QUICK RELEASE PIN
7	1FS03-5000001	SHAFT COUPLING
8	1FW05-5000003	WATER SEAL DEFLECTOR
9	HWS02-7500001	RETAINING BOLT
10	HWS02-7500002	RETAINING WASHER
11	HWS02-7500003	RETAINING SNAP RING
12	1FS02-7500005	DRIVE SHAFT
13	NPYELLOW00258	NAMEPLATE

ITEM	PART NO.	DESCRIPTION
14	2EP01-25A0012	GREEN LIGHTED PUSH BUTTON
-	ELV00-1200001	REPLACEMENT BULB FOR ITEM #15
15	2EP01-25A0016	RED MUSHROOM PUSH BUTTON
16	ELP01-2500002	SPEED CONTROL DIAL
17	2EP01-25A0022	3 POSITION TURN SWITCH
18	BGZ00-7500002	COVER BUSHING
19	TSSENSOR00012	TOP TEMPERATURE SENSOR

ITEM	DRAWING NO.	DESCRIPTION
A	C-11039	TEMPERATURE SENSOR ASSEMBLY
B	B-8412	SCRAPER BLADE ASSEMBLY
C	C-11549	PRODUCT OUTLET VALVE
D	B-11185	SHAFT SEAL ASSEMBLY
E	C-11221	IDLER BEARING & SEAL ASSEMBLY

REPLACEMENT PARTS LIST

DRAWINGS LIST

REV.	DESCRIPTION	BY	DATE	DATE BY JES	DATE	SIZE	DRAWING NUMBER
	REVISIONS			DATE 4/1/02		C	11657
				REASON NONE			SHEET 2 of 2

<b>J.C.PARDO &amp; SONS INC.</b> 1250 REAKES RD. BALTO MD. 21220 PHONE (410) 391-9600 FAX (410) 391-9042		HA-MKDL-300-CC REPLACEMENT PARTS
<small>This drawing is the property of J.C.Pardo &amp; Sons, Inc. It is to be used only for the purpose intended and is not to be reproduced or transmitted in any way without the written consent of J.C.Pardo &amp; Sons, Inc.</small>		

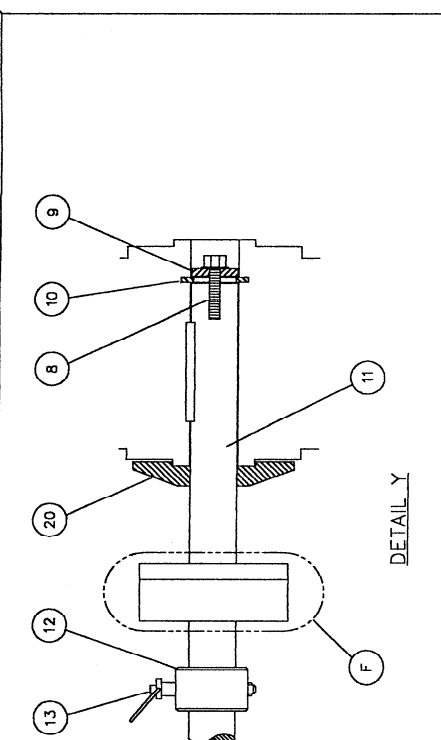

DETAIL Y

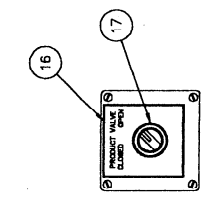

OPTIONAL PRODUCT VALVE DETAIL

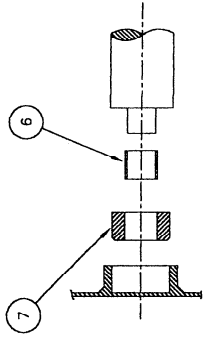

OPTIONAL SPLIT COVER DETAIL

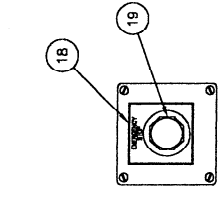

OPTIONAL EMERGENCY STOP DETAIL

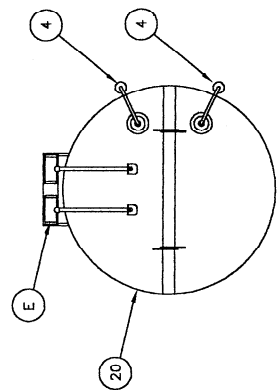

OPTIONAL SPLIT COVER DETAIL

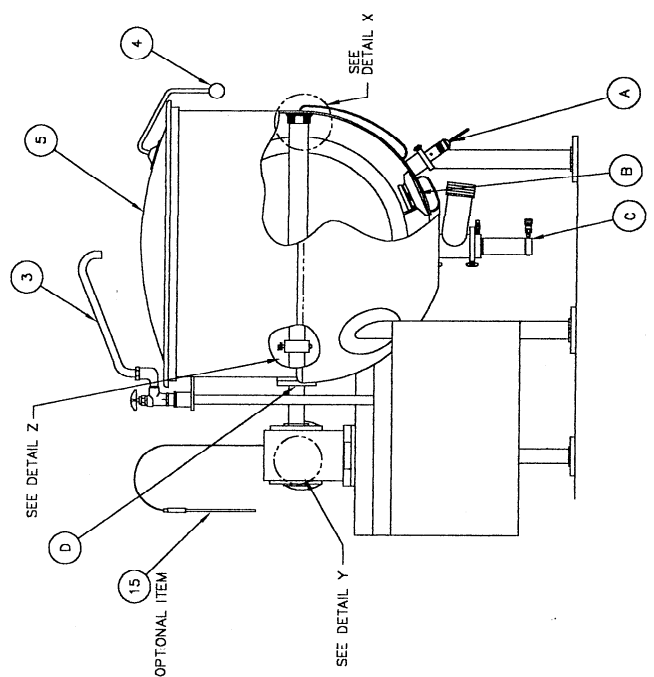
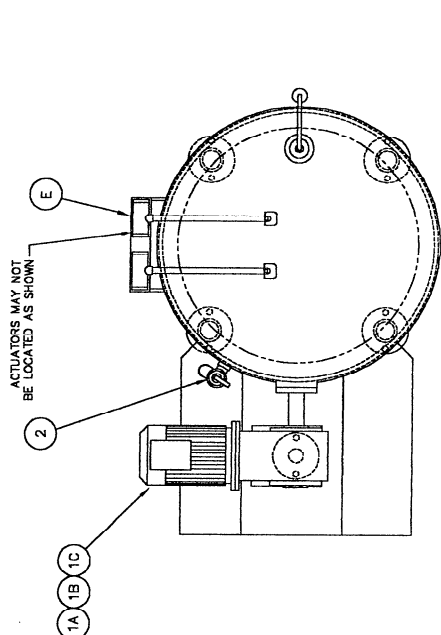

REV.	DESCRIPTION	BY	DATE	REVISIONS
<b>J.C. PARDO &amp; SONS INC.</b> 1250 REAMERS RD. BALTO MD. 21220 PHONE (410) 381-3800 FAX (410) 381-0048				ORDERED BY: DATE: 3/28/01 PART: NONE
HA-MKDL-100-CC ALL VOLTAGES REPLACEMENT PARTS				DRAWING NUMBER: 11609 SHEET: 1 of 2
<small>The drawing and all information contained therein is the property of J.C. Pardo &amp; Sons, Inc. and is not to be reproduced, stored in a retrieval system, or transmitted in any form or by any means, electronic, mechanical, photocopying, recording, or by any information storage and retrieval system, without the prior written permission of J.C. Pardo &amp; Sons, Inc.</small>				

REPLACEMENT PARTS LIST

ITEM	PART NO.	DESCRIPTION
1A	DUH03-0000007	3 HP DRIVE UNIT 208 VOLTS
-	DU903-0000010	ELECTRIC MOTOR 208 VOLTS
-	DU902-0000027	GEAR BOX
1B	DUH03-0000015	3 HP DRIVE UNIT 380 VOLTS
-	DU903-0000009	ELECTRIC MOTOR 380 VOLTS
-	DU902-0000029	GEAR BOX
1C	DUH03-0000011	3 HP DRIVE UNIT 230/460 VOLTS
-	DU903-0000011	ELECTRIC MOTOR 230/460 VOLTS
-	DU902-0000028	GEAR BOX
2	VAB01-0000007	100 PSI SAFETY VALVE
3	PBB00-7500018	FILL FAUCET
4	MSP02-0000001	RED BALL
5	1FS1B-GA00002	COVER
6	1FS01-5000004	IDLER END SLEEVE
7	1FK02-2500002	IDLER BUSHING
8	HWS02-0000002	RETAINING BOLT
9	HWS02-0000003	RETAINING WASHER
10	HWS02-0000004	RETAINING SNAP RING

REPLACEMENT PARTS LIST

ITEM	PART NO.	DESCRIPTION
11	FAS02-0000003	DRIVE SHAFT
12	FAS02-7500004	SHAFT COUPLING
13	MSS00-5000001	QUICK RELEASE PIN
14	1FW05-5000001	WATER SEAL DEFLECTOR
15	TSSENSOR00012	TOP TEMPERATURE PROBE (OPTIONAL)
16	NPYELLOW00241	NAMEPLATE (OPTIONAL)
17	2EP01-25A0044	3 POSITION TURN SWITCH (OPTIONAL)
18	NPRED0000025	NAMEPLATE (OPTIONAL)
19	2EP01-25A0016	RED MUSHROOM P.B. (OPTIONAL)
20	1V100GAL00003	SPLIT COVER (OPTIONAL)

DRAWINGS LIST

ITEM	DRAWING NO.	DESCRIPTION
A	C-11039	TEMPERATURE SENSOR ASSEMBLY
B	B-8412	SCRAPER BLADE ASSEMBLY
C	C-11549	PRODUCT OUTLET VALVE
D	B-8518	SHAFT SEAL ASSEMBLY
E	B-8539	HINGE ACTUATOR ASSEMBLY

**J.C.PARDO & SONS INC.**  
 1250 REAMES RD. BALTO MD. 21220  
 PHONE (410) 381-9800 FAX (410) 381-9042

REV. DESCRIPTION BY DATE  
 REVISIONS

DATE IN JEES  
 DATE 3/29/01  
 SCALE NONE

CREATED BY  
 APPROVED BY

HA-MKDL-100-CC ALL VOLTAGES  
 REPLACEMENT PARTS

HA-MKDL-100-CC ALL VOLTAGES  
 REPLACEMENT PARTS  
 THIS DRAWING IS THE PROPERTY OF J.C.PARDO & SONS INC. IT IS TO BE USED FOR THE MANUFACTURE OF THE PRODUCT ONLY. IT IS NOT TO BE REPRODUCED OR TRANSMITTED IN ANY FORM OR BY ANY MEANS, ELECTRONIC OR MECHANICAL, INCLUDING PHOTOCOPYING, RECORDING, OR BY ANY INFORMATION STORAGE AND RETRIEVAL SYSTEM, WITHOUT THE WRITTEN PERMISSION OF J.C.PARDO & SONS.

REV. C  
 SHEET 11609  
 2 of 2

ACTUATOR LOCATION  
MAY NOT BE AS SHOWN

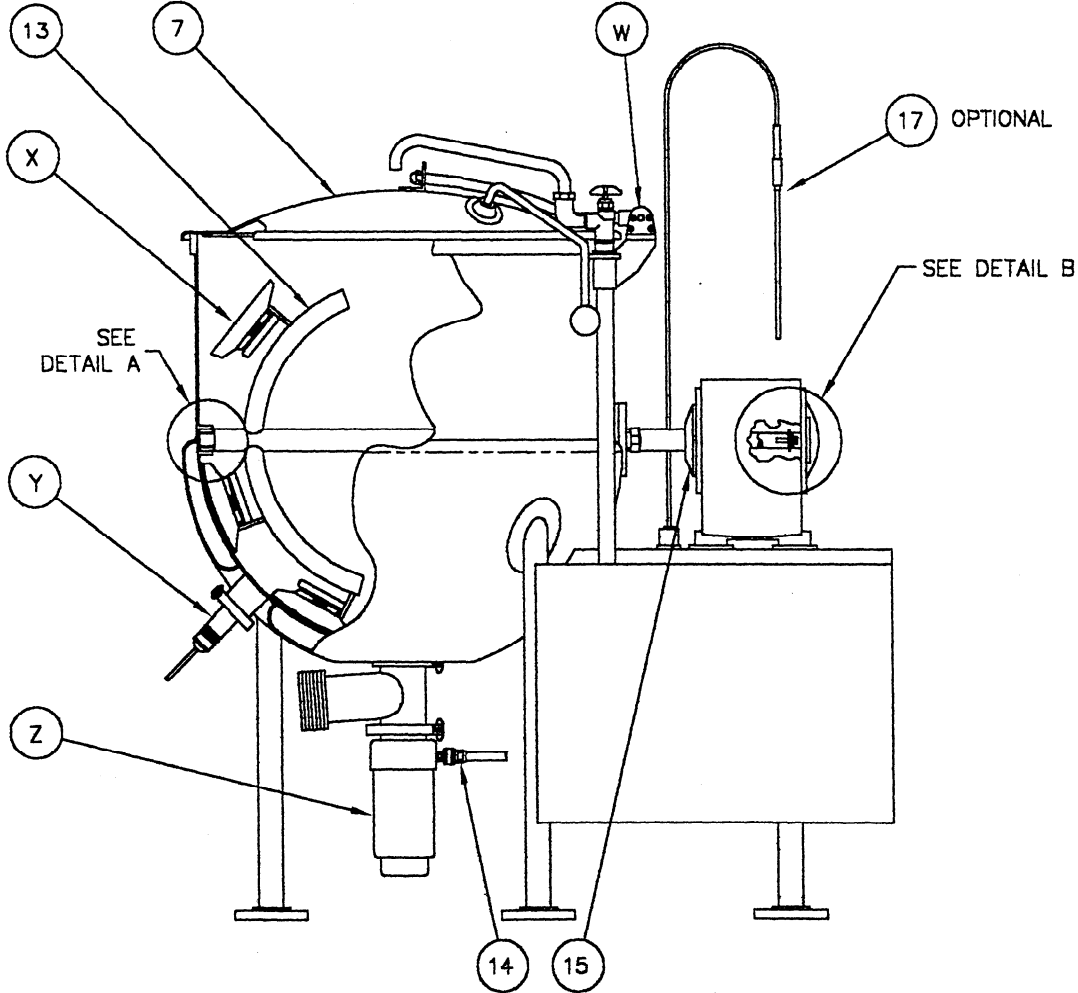
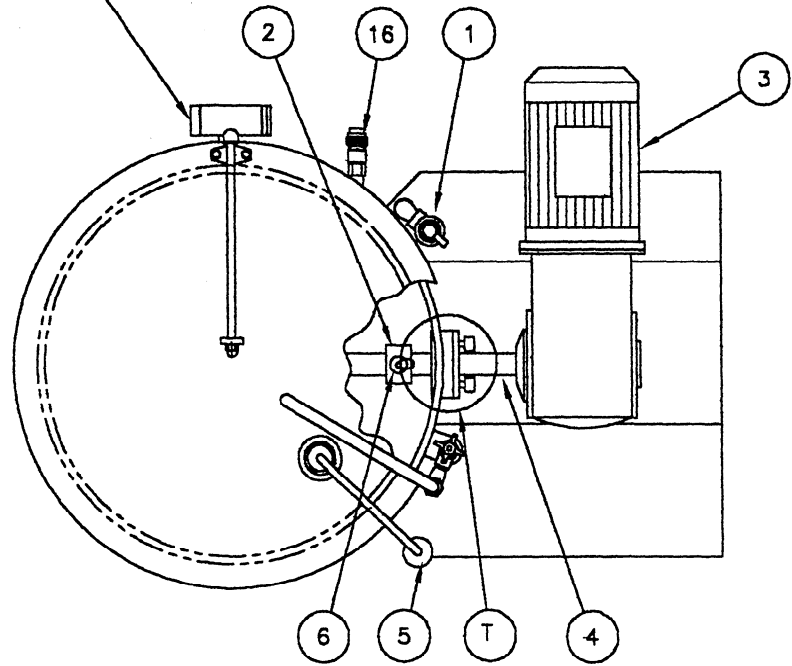

**J.C. PARDO & SONS INC.**  
 1250 REAMES RD. BALTO MD. 21220  
 PHONE (410) 381-3600 FAX (410) 381-9042

REV.	DESCRIPTION	BY	DATE
	REVISIONS		

GRE  
APP

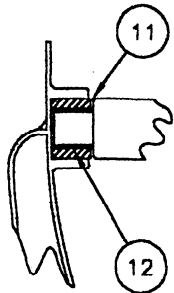

DETAIL A

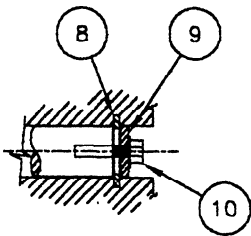

DETAIL B

## REPLACEMENT PARTS LIST

ITEM	PART NO.	DESCRIPTION
1	VAB00-7500005	SAFETY VALVE
2	FAS02-5000003	SHAFT COUPLING
3	DUH02-0000005	208 VOLT DRIVE UNIT
-	DU902-0000003	208 VOLT ELECTRIC MOTOR
-	DU901-5000004	GEARBOX
4	FAS01-5000004	DRIVE SHAFT
5	MSP02-0000001	RED BALL
6	MSS00-3700003	QUICK RELEASE PIN
7	1FS18-GA00003	KETTLE COVER
8	HWS01-5000003	RETAINING RING
9	HWS01-5000001	RETAINING WASHER
10	HWS01-5000002	RETAINING BOLT
11	1FK02-0000004	IDLER BUSHING
12	1FS01-2500003	IDLER END SLEEVE
13	1G050GAL00005	AGITATOR
14	ARB00-2500017	AIR QUICK DISCONNECT
15	1FW03-5000001	MOTOR SEAL WATER DEFLECTOR
16	ABR00-5000001	AIR QUICK DISCONNECT
17	TSENSOR00012	TOP SENSOR (OPTIONAL)

## DRAWINGS FOR REPLACEMENT PARTS

ITEM	DRAWING NO.	DESCRIPTION
T	B-11023	SHAFT SEAL & RETAINER PLATE
W	B-8539	HINGE ACTUATOR ASSEMBLY
X	B-8412 REV. B	SCRAPER BLADE ASSEMBLY
Y	C-11039 REV. A	TEMPERATURE SENSOR
Z	C-11200	PRODUCT OUTLET VALVE

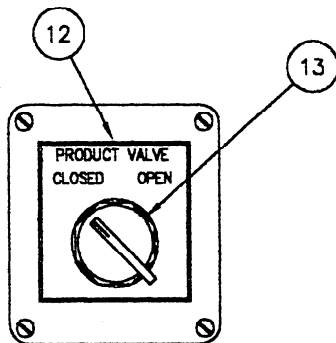

OPTIONAL  
PRODUCT VALVE  
SWITCH DETAIL

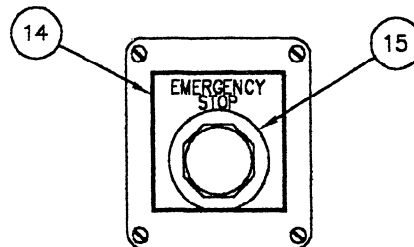

OPTIONAL  
E-STOP DETAIL

CHECKED BY:	DRAWN BY: JAY S.	HA-MKDL-60-CC 208V REPLACEMENT PARTS	SIZE:	DRAWING NUMBER:
	DATE: 2-4-00		C	11522
PROVED BY:	SCALE: NONE	This drawing and all information contained therein is the property of J.C.Pardo & Sons Inc. Balto MD. The drawing and all information is confidential and must not be made public or copied. It is loaned subject to return upon demand and is not to be used directly or indirectly in any way detrimental to J.C.Pardo & Sons.	REV.	SHEET
				1 of 1

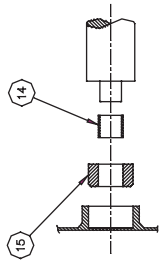
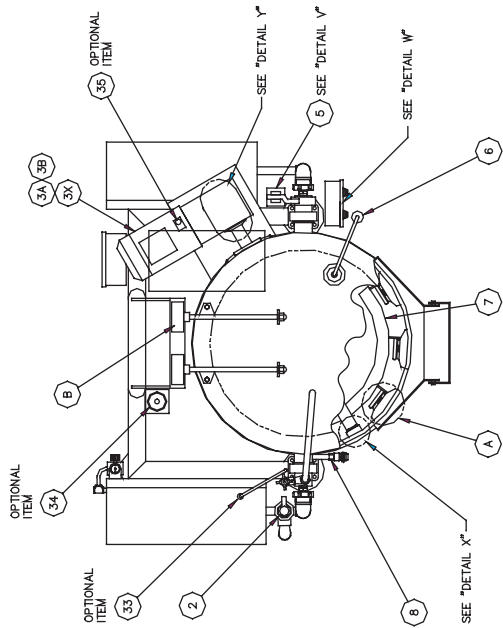

DETAIL X

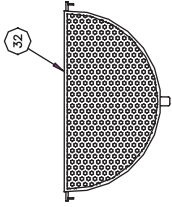

OPTIONAL HALF STRAINER

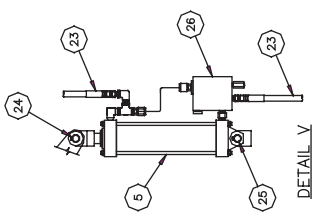

DETAIL Y

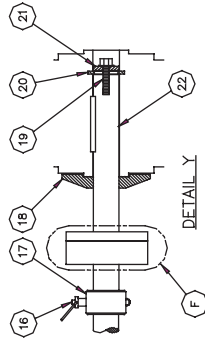

DETAIL Y

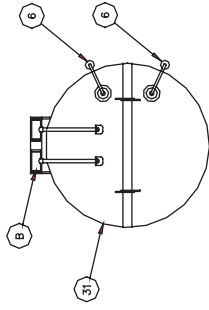

OPTIMAL SPLIT COVER DETAIL

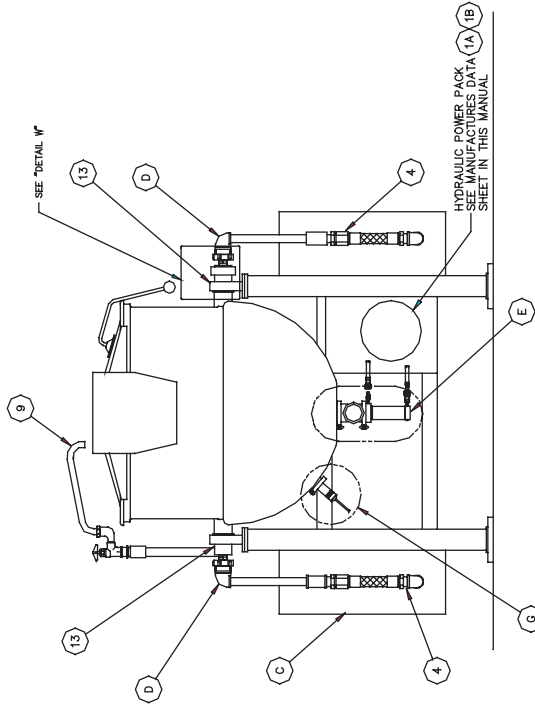

DETAIL W

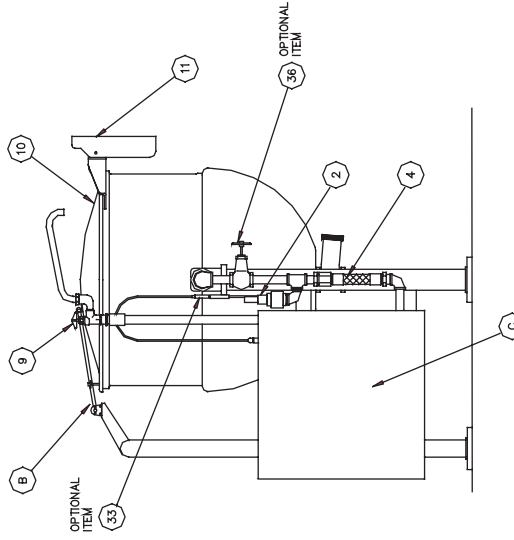

ALL COMPONENTS AND FEATURES SHOWN DO NOT APPEAR ON ALL KETTLES  
 IGNORE ALL COMPONENTS AND FEATURES NOT APPEARING ON YOUR KETTLE

REV	DESCRIPTION	DATE
A	ADD 1B, 3B & SWING SPOUT	7/05
B	REVISION	
	DATE	

**J.C. PARDO & SONS INC.**  
 1260 REARMS RD. BALTO MD. 21220  
 PHONE (410) 381-3600 FAX (410) 381-3600

HA-MKDL-150-200-T  
 REPLACEMENT PARTS  
 THIS DRAWING IS THE PROPERTY OF J.C. PARDO & SONS INC. IT IS TO BE USED ONLY FOR THE PARTS IDENTIFIED HEREIN. IT IS NOT TO BE REPRODUCED OR TRANSMITTED IN ANY FORM OR BY ANY MEANS, ELECTRONIC OR MECHANICAL, INCLUDING PHOTOCOPYING, RECORDING, OR BY ANY INFORMATION STORAGE AND RETRIEVAL SYSTEM.

REV D  
 DATE 11/87  
 REV A  
 DATE 1 of 2

ALL COMPONENTS AND FEATURES SHOWN DO NOT APPEAR ON ALL KETTLES  
 IGNORE ALL COMPONENTS AND FEATURES NOT APPEARING ON YOUR KETTLE

ITEM	PART NO.	DESCRIPTION
1A	HY800-0000014	HYDRAULIC POWER PACK 208/230/460 V
-	HY8VA-0000032	REPLACEMENT SOLENOID FOR ITEM #1A
-	SP988-8800034	REPLACEMENT COIL FOR ITEM #1A
1B	HY800-0000016	HYDRAULIC POWER PACK 380 V
-	HY8VA-0000032	REPLACEMENT SOLENOID FOR ITEM #1B
-	SP988-8800034	REPLACEMENT COIL FOR ITEM #1B
2	VAB01-2500001	SAFETY VALVE, 100 PSI
3	-----	SEE DRIVE UNIT LIST
4	PBS01-2500031	STAINLESS STEEL FLEX HOSE
5	HYS02-5000002	HYDRAULIC TILT CYLINDER
6	MSP02-0000001	RED BALL
7	1G200GAL00005	AGITATOR
8	ARB00-5000001	AIR QUICK DISCONNECT
9	PBB00-7500018	FILL FAUCET
-	PBB00-7500021	REPLACEMENT SWING SPOUT FOR ITEM #9
10	-----	KETTLE COVER
-	1FS18-GA00005	150-GAL KETTLE COVER
-	1FS18-GA00001	200-GAL KETTLE COVER
11	1FS00-0000002	FLOW DIVERTER
12	2EP01-25A0022	3 POSITION SWITCH
13	BGZ03-5000001	PILLOW BLOCK
14	1FS01-7500030	IDLER BEARING
15	1FK02-5000002	QUICK RELEASE PIN
16	MSS00-5000001	SHAFT COUPLING
17	1FS02-7500012	MOTOR SEAL WATER DEFLECTOR
18	1FW05-5000002	RETAINING BOLT
19	HWS02-3800002	RETAINING SNAP RING
20	HWS02-3800003	RETAINING WASHER
21	HWS02-3800001	DRIVE SHAFT
22	1FS02-3800006	3/8" HYDRAULIC HOSE ASSY.*
23	1YD00-3700001	TOP PIN
24	HWS01-0000003	BOTTOM PIN
25	HWS00-7500013	OVER CENTER VALVE
26	HY8VA-0000007	FUNCTION TAG
27	NPYELLOW00216	RED MUSHROOM PUSH BUTTON
28	2EP01-25A0014	YELLOW PUSH BUTTON
29	2EP01-25A0001	YELLOW PUSH BUTTON

ITEM	PART NO.	DESCRIPTION
30	2EP01-25A0002	BLUE PUSH BUTTON
31	-----	2 PIECE SPLIT COVER (OPTIONAL)
-	1Y150GAL00001	150 GAL SPLIT COVER
-	1Y200GAL00003	200 GAL SPLIT COVER
32	-----	HALF SCREEN (OPTIONAL)
-	2BSCREEN00017	150 GAL HALF SCREEN
-	2BSCREEN00016	200 GAL HALF SCREEN
33	TSSENSOR00012	TOP TEMP. PROBE (OPTIONAL)
34	ELV01-1500018	STROBE LIGHT (OPTIONAL)
35	ELV00-0000014	MOTOR KILL SWITCH (OPTIONAL)
36	PBB01-2500023	MANUAL GLOVE VALVE (OPTIONAL)

DRAWING LIST

ITEM	DRAWING NO.	DESCRIPTION
A	B-8412	SCRAPER BLADE
B	B-8415	LID ACTUATOR
C	C-11576	PLUMBING
D	C-11079	BARGO JOINT
E	D-11642	PRODUCT VALVE
F	B-11676	SHAFT SEAL
G	C-11077	TEMPERATURE SENSOR

DRIVE UNIT LIST

ITEM	PART NO.	DESCRIPTION
3A	DUH03-0000019	150 GAL. DRIVE UNIT BY VOLTAGE
-	DU903-0000013	DRIVE UNIT, 3 HP, 208V
-	DU902-3800017	3 HP ELECTRIC MOTOR, 208V
3B	DUH03-0000021	GEAR BOX
-	DU903-0000034	DRIVE UNIT, 3 HP, 380V
-	DU902-3800018	3 HP ELECTRIC MOTOR, 380V
-	DU902-3800018	GEAR BOX
3X	DUH05-0000015	200 GAL. DRIVE UNIT BY VOLTAGE
-	DU905-0000005	DRIVE UNIT, 5 HP, 208V
-	DU905-0000005	5 HP ELECTRIC MOTOR, 208V
-	DU902-3800013	GEAR BOX

MOTOR HP FOR THIS JOB IS : 3 HP.



VOLTAGE FOR THIS JOB IS : 380 V-3 PH-50 HZ.

\* CUSTOMER TO SPECIFY HOSE ASSEMBLY LENGTH.

REV	DESCRIPTION	DATE
A	ADD 1B, 3B & SWING SPOUT	7/05

REVISIONS

**J.C. PARDO & SONS INC.**  
 1260 REAMERS RD. BALTO MD. 21280  
 PHONE (410) 341-3800 FAX (410) 341-3800

DATE	BY	DESCRIPTION
8/28/02	JCS	REPLACEMENT PARTS
8/28/02	None	None

HA-MKDL-150-200-T  
 REPLACEMENT PARTS  
 11675  
 2 of 2



UNIVERSAL REPLACEMENT PARTS	
ITEM	PART NO. DESCRIPTION
1	ELBCO-0000046 PROGRAMMABLE CONTROLLER
2	ELPSW-0000002 RELAY
-	ELPSW-0000003 REPLACEMENT BASE FOR ITEM #2
3	ELV02-5000001 5 AMP FUSE
4	----- TRANSFORMER BY VOLTAGE
-	ELV05-0000003 TRANSFORMER 208/230V
-	ELV05-0000004 TRANSFORMER 380/460V
5	ELPSW-0000007 LOW VOLTAGE DISCONNECT
6	ELPSW-0000001 HIGH VOLTAGE DISCONNECT
7	ELV06-0000008 4 AMP FUSE
8	ELPSW-0000004 MOTOR CONTACTOR
9	2EP00-0000001 FAN WITH SHROUDS
10	ELV02-5000002 FNM 1 AMP FUSE

OPTIONAL TILTING KETTLE PARTS	
ITEM	PART NO. DESCRIPTION
11	ELPSW-0000005 HYDRAULIC MOTOR STARTER
-	ELV00-0000013 HEATER PACK FOR ITEM #9 208/230V
-	ELV00-0000023 HEATER PACK FOR ITEM #9 380/460V
12	ELV06-0000015 3 AMP FUSE

60 GAL. REPLACEMENT PARTS	
ITEM	PART NO. DESCRIPTION
13	----- FUSES BY VOLTAGE
-	ELV06-0000007 20 AMP FUSE 208/230V
-	ELV06-0000010 10 AMP FUSE 380/460V
14	----- INVERTER BY VOLTAGE
-	ELH02-0000008 2 HP INVERTER, 208/230V
-	ELH02-0000009 2 HP INVERTER, 380/460V

100 GAL. REPLACEMENT PARTS	
ITEM	PART NO. DESCRIPTION
13	----- FUSES BY VOLTAGE
-	ELV06-0000007 20 AMP FUSE 208/230V
-	ELV06-0000010 10 AMP FUSE 380/460V
14	----- INVERTER BY VOLTAGE
-	ELH03-0000010 3 HP INVERTER, 208/230V
-	ELH03-0000011 3 HP INVERTER, 380/460V

150/200 GAL. REPLACEMENT PARTS	
ITEM	PART NO. DESCRIPTION
13	----- FUSES BY VOLTAGE
-	ELV06-0000018 30 AMP FUSE 208/230V
-	ELV06-0000004 15 AMP FUSE 380/460V
14	----- INVERTER BY VOLTAGE
-	ELH05-0000013 5 HP INVERTER, 208/230V
-	ELH05-0000014 5 HP INVERTER, 380/460V

REV.	DESCRIPTION	BY	DATE	REVISIONS
<b>J.C.PARDO &amp; SONS INC.</b> 1250 REAMERS RD. BALTO MD. 21220 PHONE (410) 981-9800 FAX (410) 981-9042				CHECKED BY: APPROVED BY:
DATE: 3/29/01 DRAWING NUMBER: C 11608 SHEET: 2 of 2				SINGLE CONTROL PANEL ALL VOLTAGES INTERNAL REPLACEMENT PARTS <small>THIS DRAWING IS THE PROPERTY OF J.C.PARDO &amp; SONS INC. IT IS TO BE USED ONLY FOR THE PROJECT AND NOT TO BE REPRODUCED OR COPIED IN ANY MANNER WITHOUT THE WRITTEN PERMISSION OF J.C.PARDO &amp; SONS.</small>

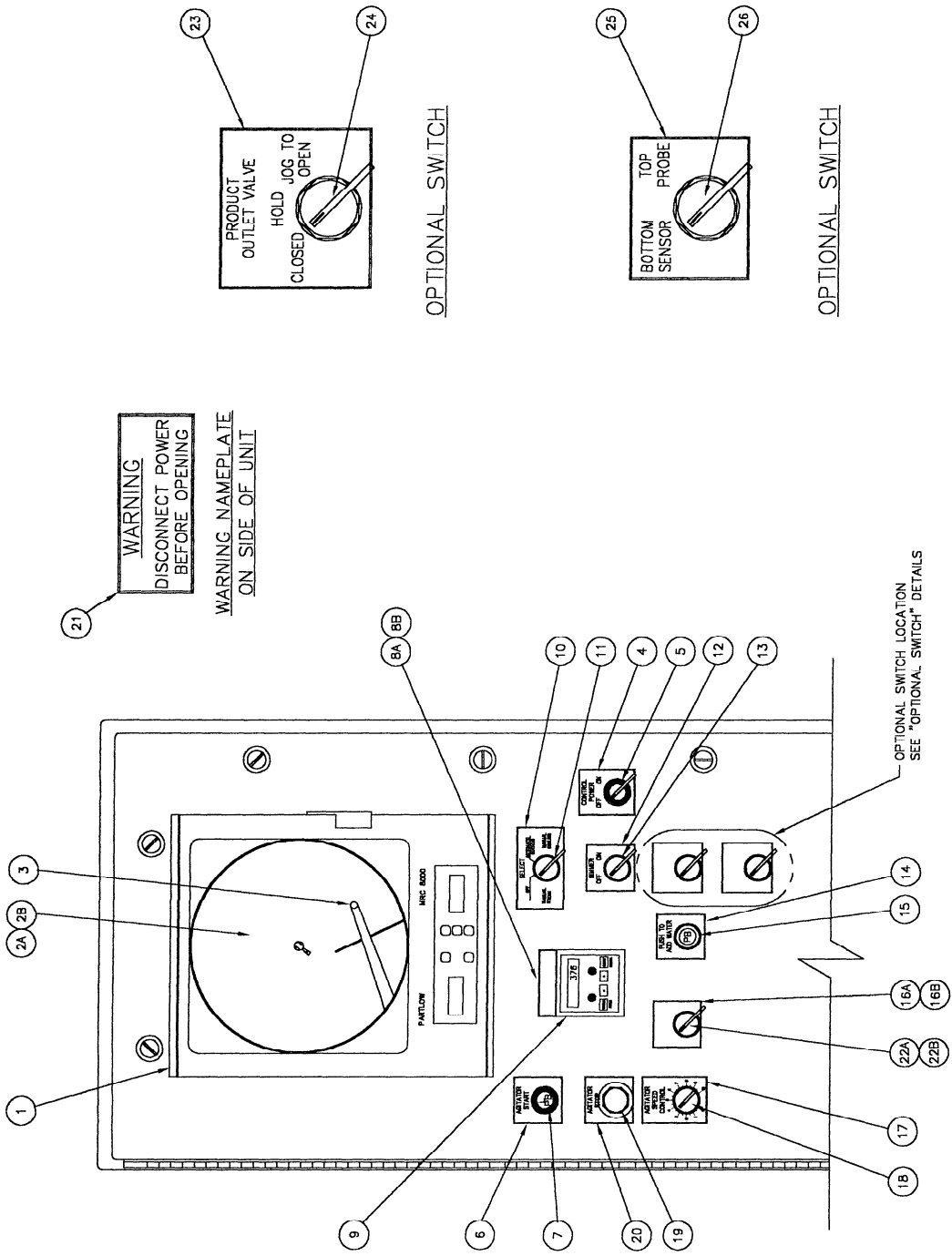

**WARNING**  
DISCONNECT POWER  
BEFORE OPENING  
ON SIDE OF UNIT

PRODUCT  
OUTLET VALVE  
HOLD JOG TO  
CLOSED  
OPEN

OPTIONAL SWITCH

TOP  
PROBE  
BOTTOM  
SENSOR

OPTIONAL SWITCH

OPTIONAL SWITCH LOCATION  
SEE "OPTIONAL SWITCH" DETAILS

REV.	DESCRIPTION	BY	DATE	ORDERED BY	APPROVED BY	DATE	REV.	REVISIONS
				JAY S.		1-13-99	C	11601
								1 of 2

**J.C.PARDO & SONS INC.**  
BALITO MD. 21220  
PHONE (410) 361-9600  
FAX (410) 361-9042

**SINGLE KETTLE FLOOR MOUNTED CONTROL  
PANEL REPLACEMENT PARTS**

DATE: 1-13-99  
SCALE: NONE

ALL INFORMATION CONTAINED HEREIN IS THE PROPERTY OF J.C.PARDO & SONS INC. IT IS TO BE USED ONLY FOR THE REPLACEMENT OF PARTS DIRECTLY OR INDIRECTLY MANUFACTURED BY J.C.PARDO & SONS.

ITEM	PART NO.	DESCRIPTION
1	EL8C0-0000042	PARTLOW 8000
-	EL977-7700019	REPLACEMENT PEN MOTOR ITEM #1
-	EL977-7700018	REPLACEMENT CHART MOTOR ITEM #1
-	EL977-7700020	REPLACEMENT TOUCH PAD COVER
2A	MSJ00-0000005	24 HOUR CHART PAPER 'F'
2B	MSJ00-0000006	24 HOUR CHART PAPER 'C'
3	MSP00-0000002	RED REPLACEMENT PEN
4	NPYELLOW00110	NAMEPLATE
5	2EP00-8800038	RED LIGHTED TURN SWITCH
-	ELV00-6000001	REPLACEMENT BULB FOR ITEM #5
6	NPYELLOW00103	NAMEPLATE
7	2EP00-8800047	GREEN LIGHTED PUSH BUTTON
-	ELV00-1200001	REPLACEMENT BULB FOR ITEM #7
8A	NPYELLOW00116	NAMEPLATE IN GALLONS
8B	NPYELLOW00155	NAMEPLATE IN LITERS
9	EL8C0-0000045	DIGITAL ATC WATER METER
10	NPYELLOW00111	NAMEPLATE
11	ELP00-8800001	FOUR POSITION SWITCH
12	NPYELLOW00107	NAMEPLATE
13	2EP00-8800006	TWO POSITION SWITCH
14	NPYELLOW00106	NAMEPLATE
15	2EP00-8800007	BLACK PUSH BUTTON
16A	NPYELLOW00119	NAMEPLATE COLD POTABLE WATER
16B	NPYELLOW00109	NAMEPLATE HOT/COLD POTABLE WATER
17	NPYELLOW00115	NAMEPLATE
18	ELP00-8800003	SPEED POT
19	2EP00-8800019	RED MUSHROOM PUSH BUTTON
20	NPYELLOW00104	NAMEPLATE
21	NPRED0000019	NAMEPLATE WARNING
22A	2EP00-8800009	TWO POSITION SWITCH
22B	2EP00-8800022	THREE POSITION SWITCH
23	NPYELLOW00241	NAMEPLATE (OPTIONAL)
24	2EP00-8800044	THREE POSITION SWITCH (OPTIONAL)
25	NPYELLOW00194	NAMEPLATE (OPTIONAL)
26	2EP00-8800043	TWO POSITION SWITCH (OPTIONAL)

# REPLACEMENT PARTS

REV.	DESCRIPTION	BY	DATE
	REVISIONS		
<p><b>J.C.PARDO &amp; SONS INC.</b>          1250 REAMES RD. BALTO MD. 21220          PHONE (410) 381-5800 FAX (410) 381-8042</p>			
ORDER BY	DATE	BY	DATE
	JAN 5		1-13-99
APPROVED BY	NONE		
REV.	DESCRIPTION	REV.	DATE
C	SINGLE KETTLE FLOOR MOUNTED CONTROL PANEL REPLACEMENT PARTS	C	11601
			2 of 2

In filling out this order, please refer to the product literature for the correct part number. If you are unable to determine the correct part number, please contact J.C.Pardo & Sons, Inc. at (410) 381-5800. We will be glad to assist you in any way.

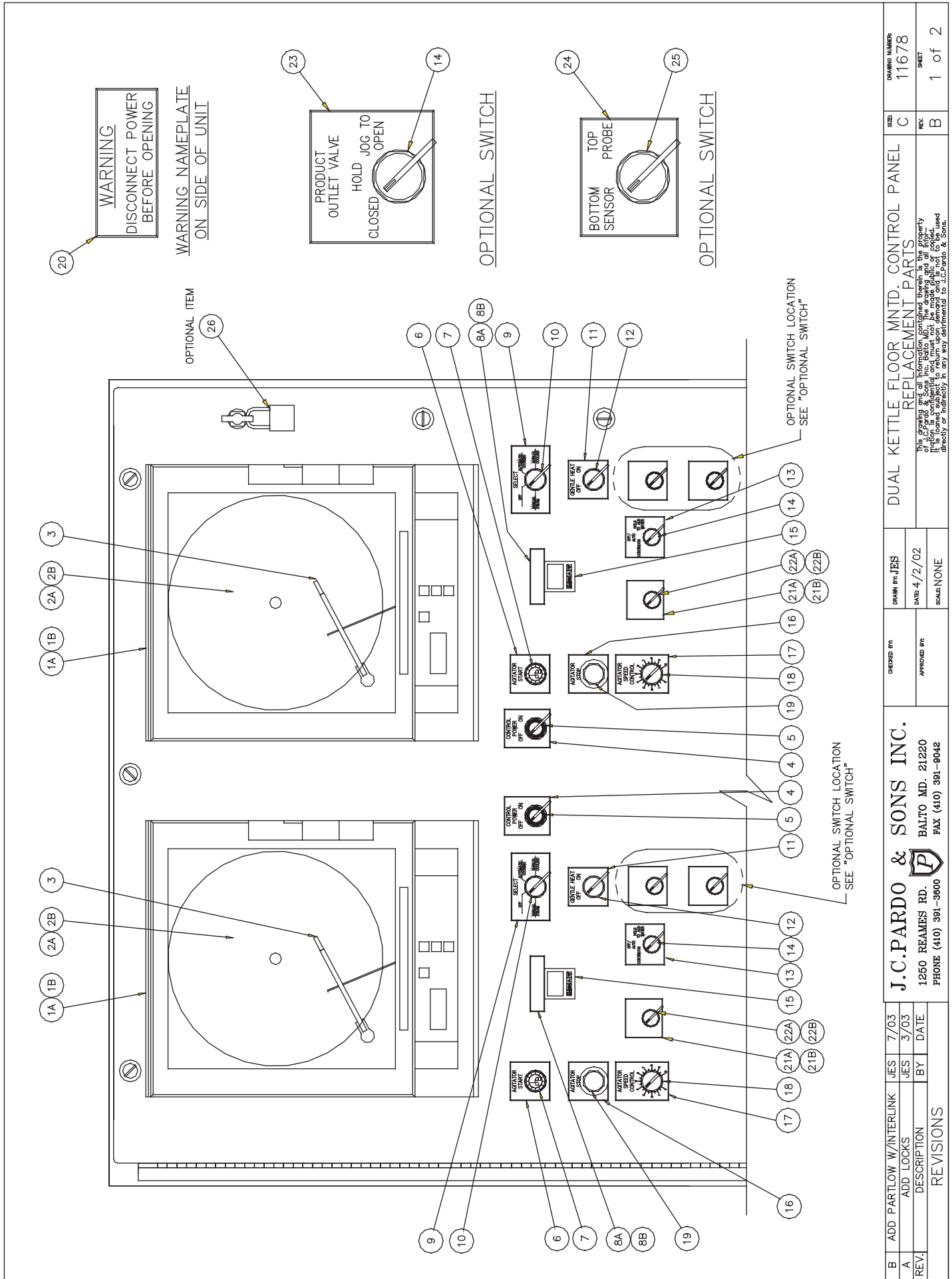

B		ADD PARTLOW W/INTERLINK	JES	7/03	J.C.PARDO & SONS INC.		DUAL KETTLE FLOOR MNTD. CONTROL PANEL		SIZE	C	DRAWING NUMBER	11678
A		ADD LOCKS	JES	3/03	1250 REAMES RD. BALTO MD. 21220		REPLACEMENT PARTS		REV.	B	SHEET	
REV.		DESCRIPTION	BY	DATE	PHONE (410) 391-0600		FAX (410) 391-9042		1 of 2			
		REVISIONS										

# REPLACEMENT PARTS

ITEM	PART NO.	DESCRIPTION
1A	EL8C0-0000042	PARTLOW 8000
1B	EL8C0-0000070	PARTLOW 8000 W/INTERLINK(OPTIONAL)
-	EL977-7700019	REPLACEMENT PEN MOTOR: #1A,1B
-	EL977-7700018	REPLACEMENT CHART MOTOR: #1A,1B
-	EL977-7700020	REPLACEMENT TOUCH PAD: 1A,1B
-	ELP00-0000037	REPLACEMENT DOOR: #1A,1B
-	ELP00-0000036	REPLACEMENT DOOR WINDOW: #1A,1B
2A	MSJ00-0000005	24 HOUR CHART PAPER °F
2B	MSJ00-0000006	24 HOUR CHART PAPER °C
3	MSP00-0000002	RED REPLACEMENT PEN
4	NPYELLOW00110	NAMEPLATE
5	2EP00-8800025	RED LIGHTED TURN SWITCH
-	ELV00-6000001	REPLACEMENT BULB FOR ITEM #5
6	NPYELLOW00103	NAMEPLATE
7	2EP00-8800047	GREEN LIGHTED PUSH BUTTON
-	ELV00-1200001	REPLACEMENT BULB FOR ITEM #7
8A	NPYELLOW00116	NAMEPLATE IN GALLONS
8B	NPYELLOW00155	NAMEPLATE IN LITERS
9	NPYELLOW00111	NAMEPLATE
10	ELP00-8800001	FOUR POSITION SWITCH
11	NPYELLOW00107	NAMEPLATE
12	2EP00-8800006	TWO POSITION SWITCH
13	NPYELLOW00260	NAMEPLATE
14	2EP00-8800044	THREE POSITION SWITCH
15	EL8C0-0000067	DIGITAL REDLION WATER COUNTER
-	ELV02-5000019	REPLACEMENT .315A FUSE ITEM #15
16	NPYELLOW00104	NAMEPLATE
17	NPYELLOW00115	NAMEPLATE
18	ELP00-8800003	SPEED POT
19	2EP00-8800019	RED MUSHROOM PUSH BUTTON
20	NPRED0000019	NAMEPLATE WARNING
21A	NPYELLOW00119	NAMEPLATE
21B	NPYELLOW00109	NAMEPLATE (OPTIONAL)
22A	2EP00-8800009	TWO POSITION SWITCH
22B	2EP00-8800022	THREE POSITION SWITCH (OPTIONAL)
23	NPYELLOW00241	NAMEPLATE (OPTIONAL)
24	NPYELLOW00194	NAMEPLATE (OPTIONAL)
25	2EP00-8800043	TWO POSITION SWITCH (OPTIONAL)
26	HWLOCKS00001	PADLOCK AND KEY SET

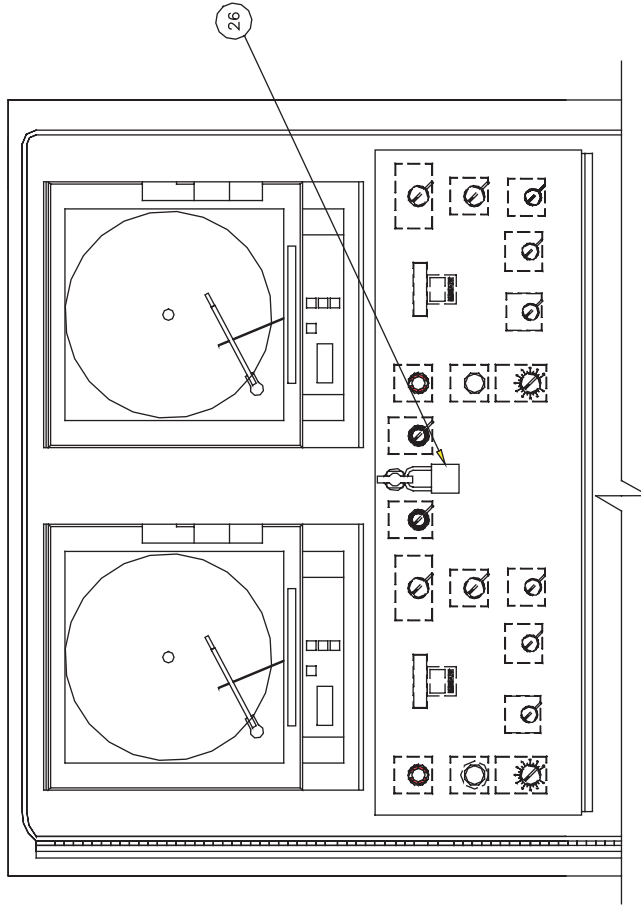

OPTIONAL SWITCH COVER

REV.	DESCRIPTION	DATE	BY	DATE	REV.	SIZE	DRAWING NUMBER
B	ADD PARTLOW W/INTERLINK	7/03	JES	7/03	C	C	11678
A	ADD LOCKS	3/03	JES	3/03	B	B	11678
REVISIONS	<p>REVISIONS</p> <p>REPLACEMENT PARTS</p> <p>DUAL KETTLE FLOOR MNTD. CONTROL PANEL</p>						
<p>APPROVED BY: _____</p> <p>DATE: 4/2/02</p> <p>SCALE: NONE</p> <p>DRAWN BY: JES</p>							<p>REV. SHEET</p> <p>2 of 2</p>

**J.C.PARDO & SONS INC.**  
 1250 REAMES RD. BALTO MD. 21220  
 PHONE (410) 391-0600 FAX (410) 391-9042

This drawing and all information contained therein is the property of J.C. Pardo & Sons, Inc. and shall not be divulged or copied in any form without the written consent of J.C. Pardo & Sons, Inc. It is loaned subject to return upon demand and is not to be used except as indicated in any drawings, documents or records of J.C. Pardo & Sons.

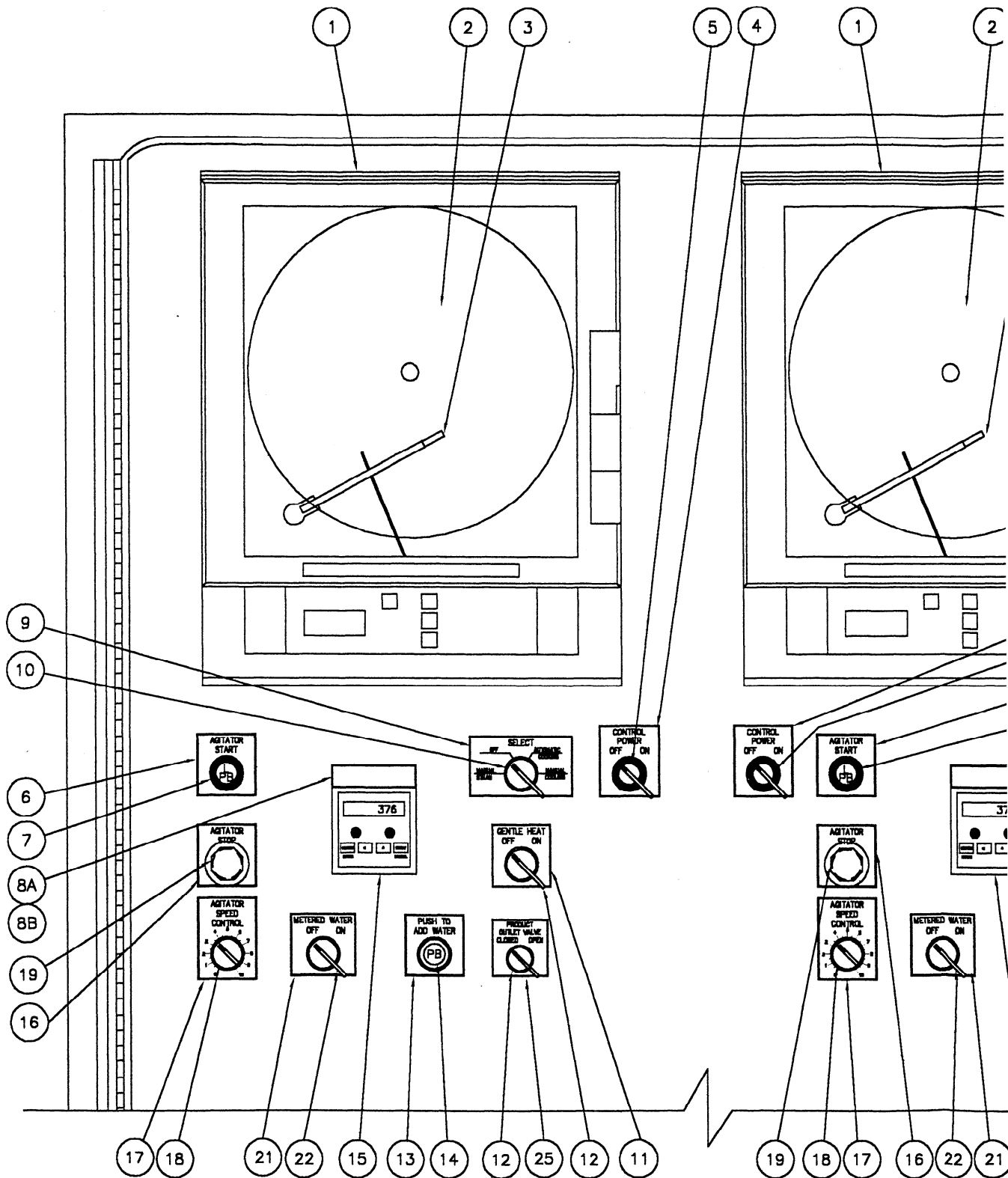

**J.C. PARDO & SONS INC.**  
 1250 REAMES RD. BALTO MD. 21220  
 PHONE (410) 391-3600 FAX (410) 391-9042

CHECKED BY:

APPROVED BY:

REV.	DESCRIPTION	BY	DATE
	REVISIONS		

# REPLACEMENT PARTS

ITEM	PART NO.	DESCRIPTION
1	EL8CO-0000042	PARTLOW 8000
-	EL977-7700018	CHART MOTOR FOR ITEM #1
-	EL977-7700019	PEN MOTOR FOR ITEM #1
-	EL977-7700020	TOUCH PAD FOR ITEM #1
2A	MSJ00-0000005	CHART PAPER IN °F
2B	MSJ00-0000006	CHART PAPER IN °C
3	MSP00-0000002	RED REPLACEMENT PEN
4	NPYELLOW00110	FUNCTION TAG
5	2EP00-8800025	RED LIGHTED TURN SWITCH
-	ELV00-6000001	REPLACEMENT BULB FOR SWITCH #5
6	NPYELLOW00103	FUNCTION TAG
7	2EP00-8800008	GREEN LIGHTED TURN SWITCH
-	ELV00-2400001	REPLACEMENT BULB FOR SWITCH #7
8A	NPYELLOW00116	FUNCTION TAG FOR GALLONS
8B	NPYELLOW00155	FUNCTION TAG FOR LITERS
9	NPYELLOW00111	FUNCTION TAG
10	ELP00-8800001	FOUR POSITION SWITCH
11	NPYELLOW00107	FUNCTION TAG
12	2EP00-8800006	TWO POSITION TURN SWITCH
13	NPYELLOW00106	FUNCTION TAG
14	2EP00-8800007	BLACK PUSH BUTTON
15	EL8CO-0000045	DIGITAL ATC WATER COUNTER
16	NPYELLOW00104	FUNCTION TAG
17	NPYELLOW00115	FUNCTION TAG
18	ELP00-8800003	SPEED POT
19	2EP00-8800019	RED MUSHROOM PUSH BUTTON
20	NPRED00000019	WARNING TAG
21	NPYELLOW00119	FUNCTION TAG
22	2EP00-8800009	2 POSITION TURN SWITCH
23	NPYELLOW00194	FUNCTION TAG
24	2EP00-8800043	2 POSITION TURN SWITCH
25	NPYELLOW00118	FUNCTION TAG

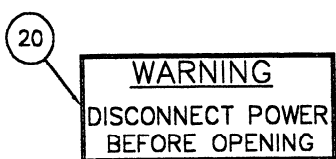
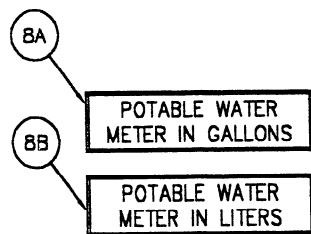
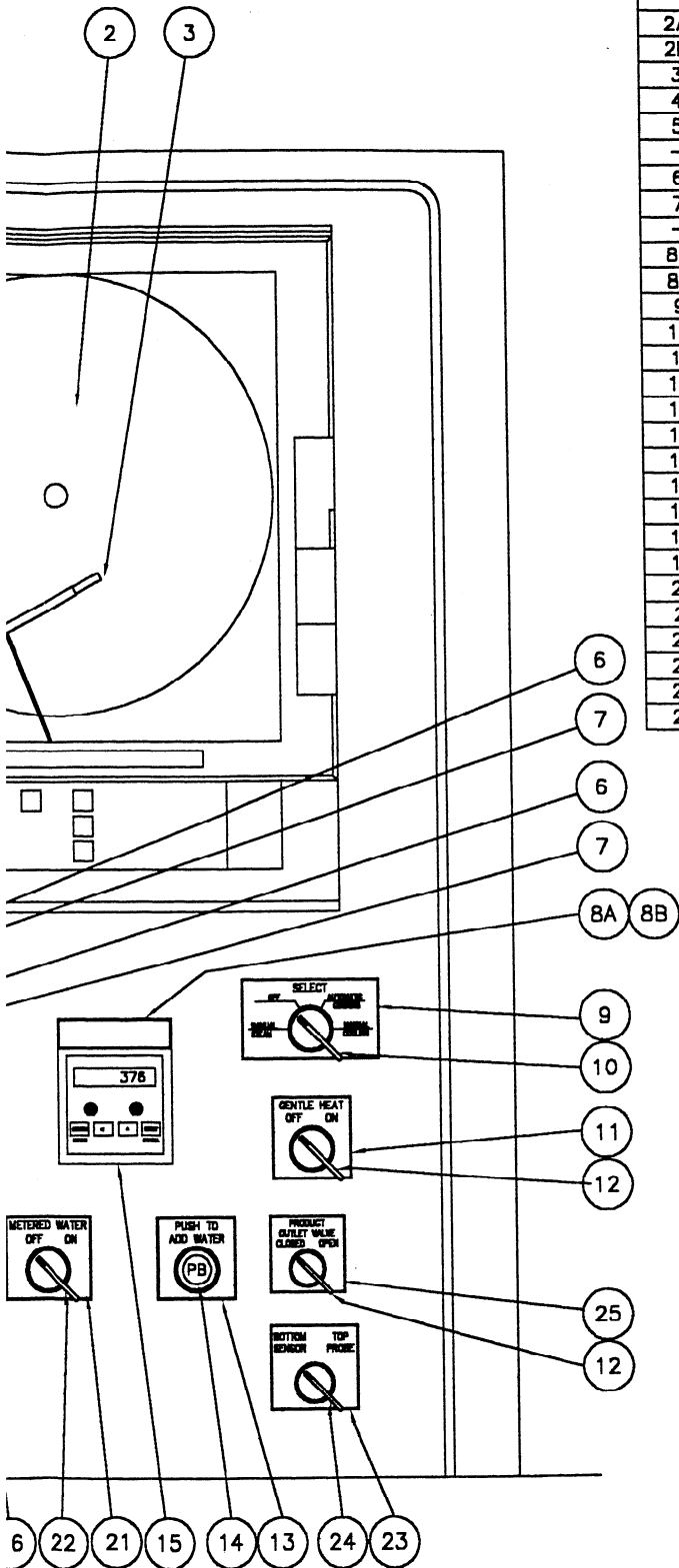

CHECKED BY:	DRAWN BY: JES	<b>DUAL CONTROL PANEL REPLACEMENT PARTS</b>	SIZE: C	DRAWING NUMBER: 11533
APPROVED BY:	DATE: 2/1/00		REV.	SHEET 1 of 1
SCALE: NONE		<small>This drawing and all information contained therein is the property of J.C.Pardo &amp; Sons Inc. Balto MD. The drawing and all information is confidential and must not be made public or copied. It is loaned subject to return upon demand and is not to be used directly or indirectly in any way detrimental to J.C.Pardo &amp; Sons.</small>		

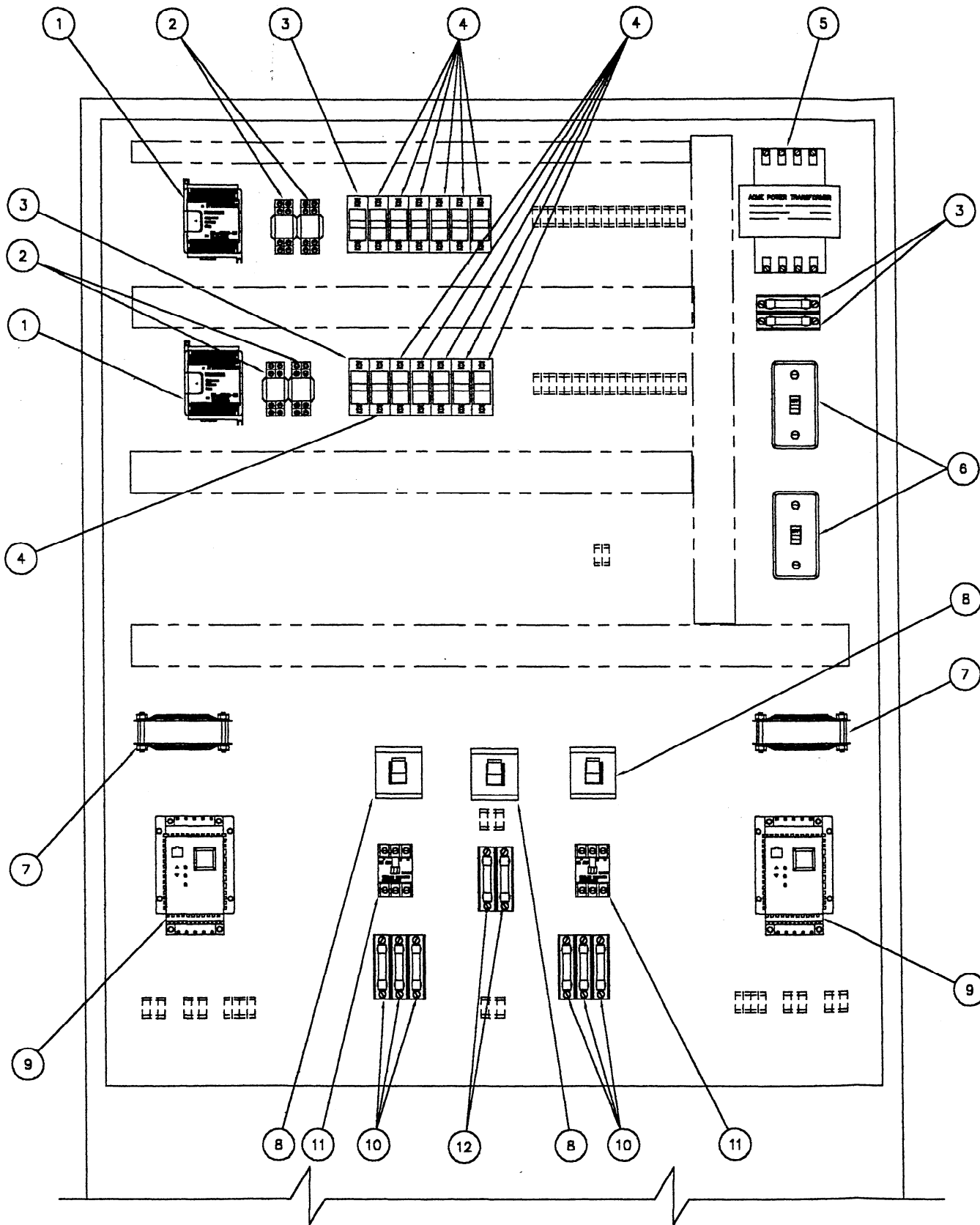

**J.C. PARDO & SONS INC.**

1250 REAMES RD. BALTO MD. 21220  
 PHONE (410) 391-3600 FAX (410) 391-9042



CHECKED BY:

DRAWN BY: JES

APPROVED BY:

DATE: 8-24-

SCALE: NONE

REV.	DESCRIPTION	BY	DATE
	REVISIONS		

# REPLACEMENT PARTS

ITEM	PART NO.	DESCRIPTION
1	EL8CO-0000046	MITSUBISHI CONTROLLER
2	ELPSW-0000002	RELAY
-	ELPSW-0000003	RELAY MODULE BASE
3	ELV02-5000001	5 AMP FUSE
4	ELV02-5000002	1 AMP FUSE
5	ELV10-0000001	TRANSFORMER 1000VA
6	ELPSW-0000007	DUAL POLE SWITCH
7	2EP00-0000001	FAN W/ SHROUDING
8	ELPSW-0000001	3 POLE SWITCH
9	ELH02-0000008	2 H.P. INVERTER 208V
10	ELV06-0000004	15 AMP FUSE
11	ELPSW-0000004	MOTOR CONTACTOR
12	ELV06-0000002	8 AMP FUSE

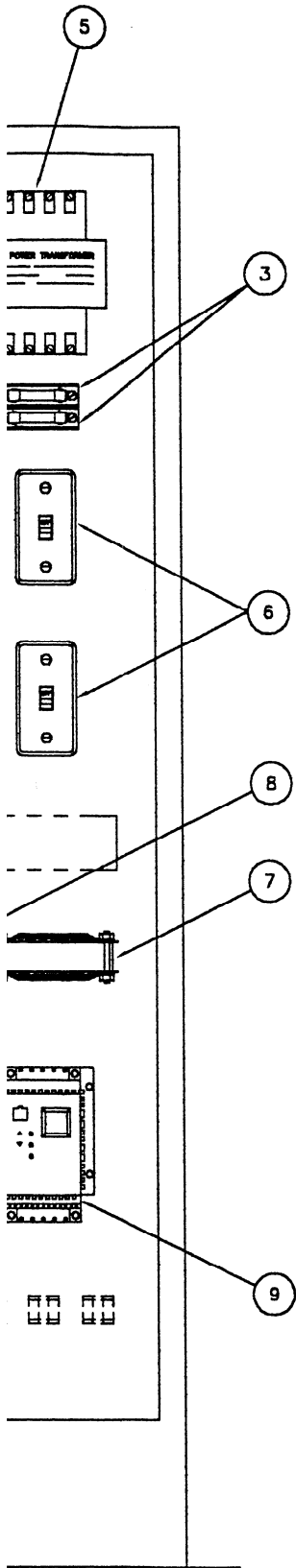

CHECKED BY:	DRAWN BY: JES	<b>DUAL CONTROL PANEL INTERIOR 2HP-208v REPLACEMENT PARTS</b>	SIZE:	DRAWING NUMBER:
APPROVED BY:	DATE: 8-24-00		C	11550
	SCALE: NONE		REV.	SHEET
This drawing and all information contained therein is the property of J.C.Pardo & Sons Inc. Balto. Md. The drawing and all information is confidential and must not be made public or copied. It is loaned subject to return upon demand and is not to be used directly or indirectly in any way detrimental to J.C.Pardo & Sons.				1 of 1



REPLACEMENT PARTS		
ITEM	PART NO.	DESCRIPTION
1	EL8C0-0000042	PARTLOW 8000
-	EL977-7700019	REPLACEMENT PEN MOTOR ITEM #1
-	EL977-7700018	REPLACEMENT CHART MOTOR ITEM #1
-	EL977-7700020	REPLACEMENT TOUCH PAD COVER
-	ELP00-0000037	REPLACEMENT DOOR FOR ITEM #1
-	ELP00-0000036	REPLACEMENT DOOR WINDOW ITEM #1
2	MSJ00-0000005	24 HOUR CHART PAPER 'F'
3	MSP00-0000002	RED REPLACEMENT PEN
4	NPYELLOW00110	NAMEPLATE
5	2EP00-8800025	RED LIGHTED TURN SWITCH
-	ELV00-6000001	REPLACEMENT BULB FOR ITEM #5
6	NPYELLOW00109	NAMEPLATE
7	2EP00-8800022	THREE POSITION SWITCH
8	NPYELLOW00257	NAMEPLATE
9	NPYELLOW00111	NAMEPLATE
10	ELP00-8800001	FOUR POSITION SWITCH
11	NPYELLOW00107	NAMEPLATE
12	2EP00-8800006	TWO POSITION SWITCH
13	NPYELLOW00106	NAMEPLATE
14	2EP00-8800007	BLACK PUSH BUTTON
15	EL8C0-0000067	DIGITAL REDUION WATER COUNTER
-	ELV02-5000019	REPLACEMENT .315A FUSE ITEM #15
16	NPRED00000019	NAMEPLATE WARNING
17	HWLOCK0000001	PADLOCK WITH KEYS
18	NPYELLOW00194	NAMEPLATE (OPTIONAL)
19	2EP00-8800043	TWO POSITION SWITCH (OPTIONAL)

REV.1	DESCRIPTION	BY	DATE	REVISIONS
<b>J.C.PARDO &amp; SONS INC.</b> 1250 REAMES RD. BALTO MD. 21220 PHONE (410) 381-3600 FAX (410) 381-9042				DUAL KETTLE FLOOR MNTD. CONTROL PANEL REPLACEMENT PARTS (MARACOPA ONLY)
DRAWN BY: JES DATE: 3/27/02 SCALE: NONE				Dwg. No.: 11656 SHEET: 2 of 2

THE DRAWING IS AN INSTRUMENT OF SERVICE OF J.C.PARDO & SONS INC. AND IS THE PROPERTY OF J.C.PARDO & SONS INC. IT IS TO BE USED ONLY FOR THE PROJECT AND SITE SPECIFICALLY IDENTIFIED THEREON. ANY REUSE OR MODIFICATION OF THIS DRAWING WITHOUT THE WRITTEN CONSENT OF J.C.PARDO & SONS INC. IS STRICTLY PROHIBITED.

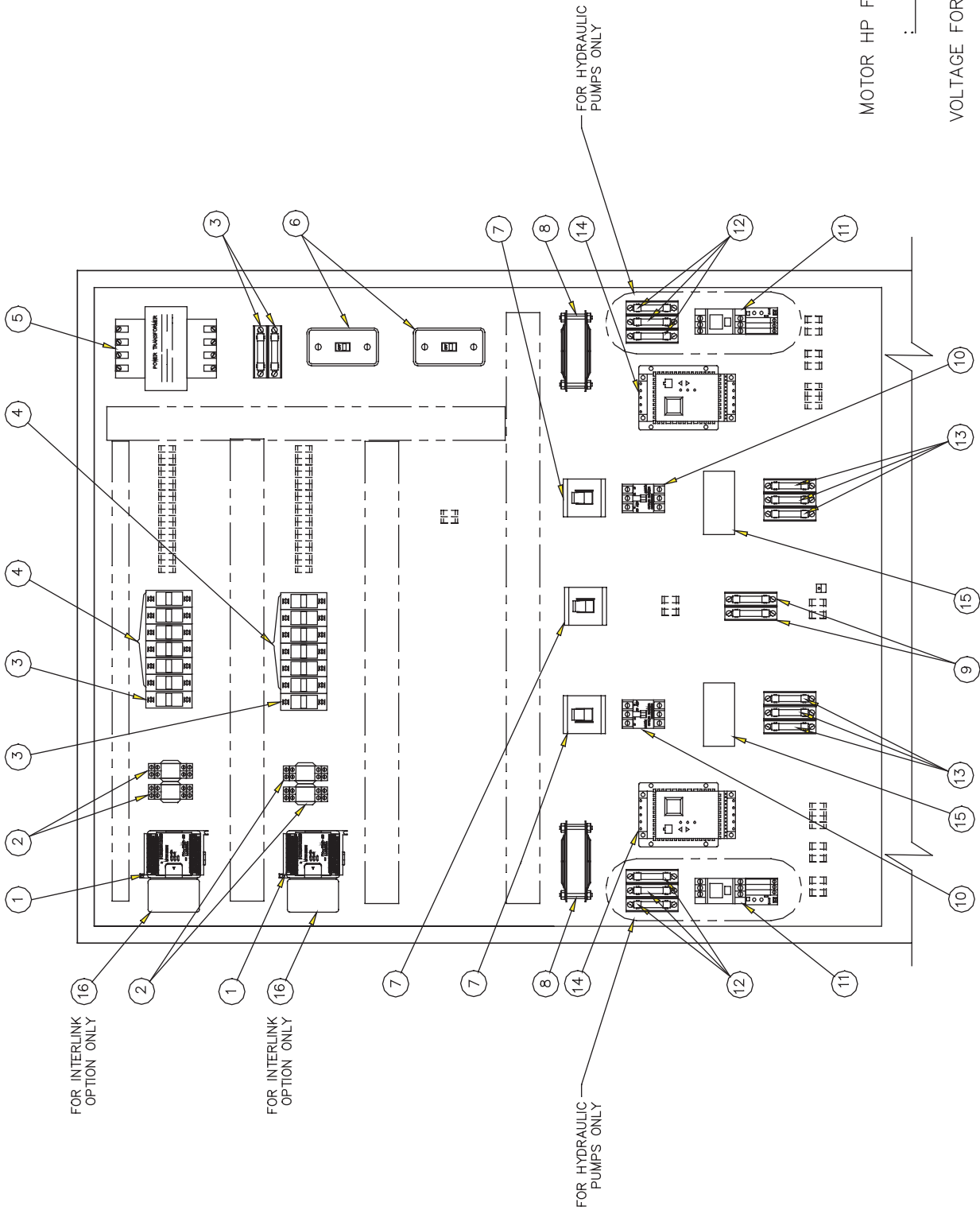

MOTOR HP FOR THIS JOB IS : 3 HP.

VOLTAGE FOR THIS JOB IS : 380 V- 3 PH- 50 HZ.

#15 IS ONLY FOR 2-3 HP MOTORS ONLY.

ADDED #15	JFS	6/01	INTERNAL DUAL CONTROL PANEL 2, 3 & 5HP	SIZE	DRAWING NUMBER
DESCRIPTION	BY	DATE	KETTLES 208/230/380/460V	C	11614
REVISIONS			FOR INTERLINK OPTION ONLY FOR HYDRAULIC PUMPS ONLY	REV.	SHEET
				A	1 of 2

**J.C.PARDO & SONS INC.**  
 1250 REAMES RD. BALTO MD. 21220  
 PHONE (410) 391-3800 FAX (410) 391-8042

INTERNAL DUAL CONTROL PANEL 2, 3 & 5HP  
 KETTLES 208/230/380/460V  
 FOR INTERLINK OPTION ONLY  
 FOR HYDRAULIC PUMPS ONLY

UNIVERSAL REPLACEMENT PARTS	
ITEM	PART NO. DESCRIPTION
1	EL8C0-0000046 PROGRAMMABLE CONTROLLER
2	ELPSW-0000002 RELAY
3	ELPSW-0000003 REPLACEMENT BASE FOR ITEM #2
4	ELV02-5000001 5 AMP FUSE
5	ELV02-5000002 1 AMP FUSE
6	ELV10-0000001 TRANSFORMER BY SYSTEM VOLTAGE
7	ELV10-0000002 TRANSFORMER - 208/380V SYSTEM
8	ELV10-0000003 TRANSFORMER - 230/460V SYSTEM
9	ELPSW-0000007 LOW VOLTAGE DISCONNECT
10	ELPSW-0000001 HIGH VOLTAGE DISCONNECT
11	2EP00-0000001 FAN WITH SHROUDS
12	ELV06-0000002 FUSES BY SYSTEM VOLTAGE
13	ELV06-0000002 8 AMP FUSE - 208V SYSTEM
14	ELV06-0000042 7 AMP FUSE - 230V SYSTEM
15	ELV06-0000019 5 AMP FUSE - 380V SYSTEM
16	ELV06-0000008 4 AMP FUSE - 460V SYSTEM
17	ELPSW-0000004 MOTOR CONTACTOR

OPTIONAL HYDRAULIC PUMP STARTER PARTS	
ITEM	PART NO. DESCRIPTION
11	ELPSW-0000005 HYDRAULIC MOTOR STARTER
12	ELV00-0000013 HEATER PACK FOR ITEM #9 208/230V
13	ELV00-0000023 HEATER PACK FOR ITEM #9 380/460V
14	ELV06-0000015 3 AMP FUSE

2 HP MOTOR REPLACEMENT PARTS	
ITEM	PART NO. DESCRIPTION
13	ELV06-0000007 FUSES BY VOLTAGE
14	ELV06-0000010 20 AMP FUSE 208/230V
15	ELV06-0000010 10 AMP FUSE 380/460V
16	ELH02-0000008 INVERTER BY VOLTAGE
17	ELH02-0000008 2 HP INVERTER, 208/230V
18	ELH02-0000009 2 HP INVERTER, 380/460V
19	ELV00-0000024 LINE REACTORS BY VOLTAGE & HP
20	ELV00-0000024 LINE REACTOR 2HP 208/230/460V

3 HP MOTOR REPLACEMENT PARTS	
ITEM	PART NO. DESCRIPTION
13	ELV06-0000007 FUSES BY VOLTAGE
14	ELV06-0000010 20 AMP FUSE 208/230V
15	ELV06-0000010 10 AMP FUSE 380/460V
16	ELH03-0000010 INVERTER BY VOLTAGE
17	ELH03-0000010 3 HP INVERTER, 208/230V
18	ELH03-0000011 3 HP INVERTER, 380/460V
19	ELV00-0000024 LINE REACTORS BY VOLTAGE & HP
20	ELV00-0000024 LINE REACTOR 3HP 208/230/460V

5 HP MOTOR REPLACEMENT PARTS	
ITEM	PART NO. DESCRIPTION
13	ELV06-0000018 FUSES BY VOLTAGE
14	ELV06-0000004 30 AMP FUSE 208/230V
15	ELV06-0000004 15 AMP FUSE 380/460V
16	ELH05-0000013 INVERTER BY VOLTAGE
17	ELH05-0000013 5 HP INVERTER, 208/230V
18	ELH05-0000014 5 HP INVERTER, 380/460V

OPTIONAL INTERLINK REPLACEMENT PARTS	
ITEM	PART NO. DESCRIPTION
16	EL8C0-0000057 COMMUNICATIONS MODULE FOR CONTROLLER

MOTOR HP FOR THIS JOB IS : 3 HP.

VOLTAGE FOR THIS JOB IS : 380 V- 3 PH- 50HZ.

B	ADDED IA SPECS	JES	3/02	INTERNAL DUAL CONTROL PANEL 2, 3 & 5HP	SIZE	C	DRAWING NUMBER	11614
A	ADDED #15	JES	6/01	KETTLES 208/230/380/460V	REV.	B	SHEET	2 of 2
REV.	DESCRIPTION	BY	DATE	REVISIONS	REV.	B	SHEET	2 of 2

**J.C.PARDO & SONS INC.**  
 1250 REAMES RD. BALTO MD. 21220  
 PHONE (410) 391-3800 FAX (410) 391-8042

This drawing & specification are the property of J.C.Pardo & Sons, Inc. and must not be made public or copied in any way without the written consent of J.C.Pardo & Sons, Inc. Any unauthorized use, reproduction, or distribution is strictly prohibited and may be subject to legal action.

FOR MOTOR HOOKUPS ON THE  
RIGHT SIDE MIRROR THIS LAYOUT

\* THE PASTA KETTLE HAS  
ONLY FIVE 1 AMP FUSES

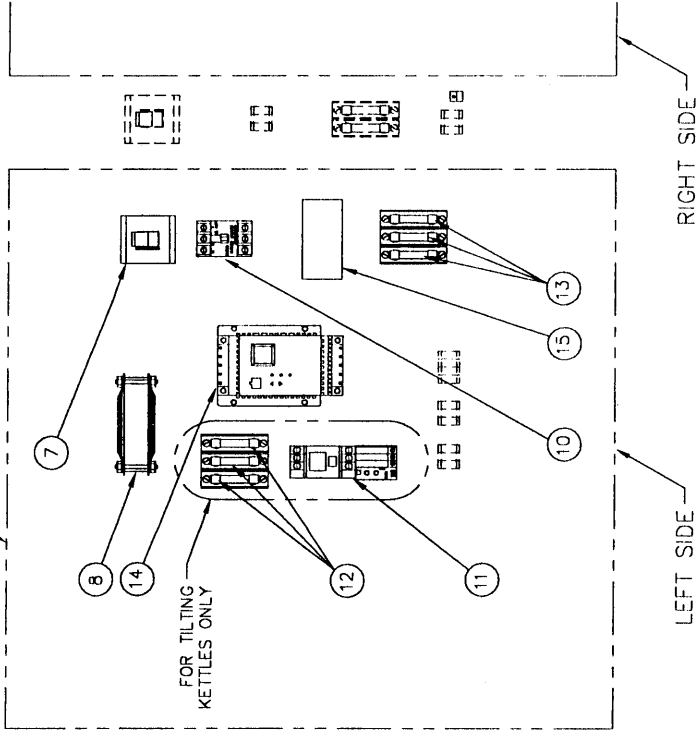
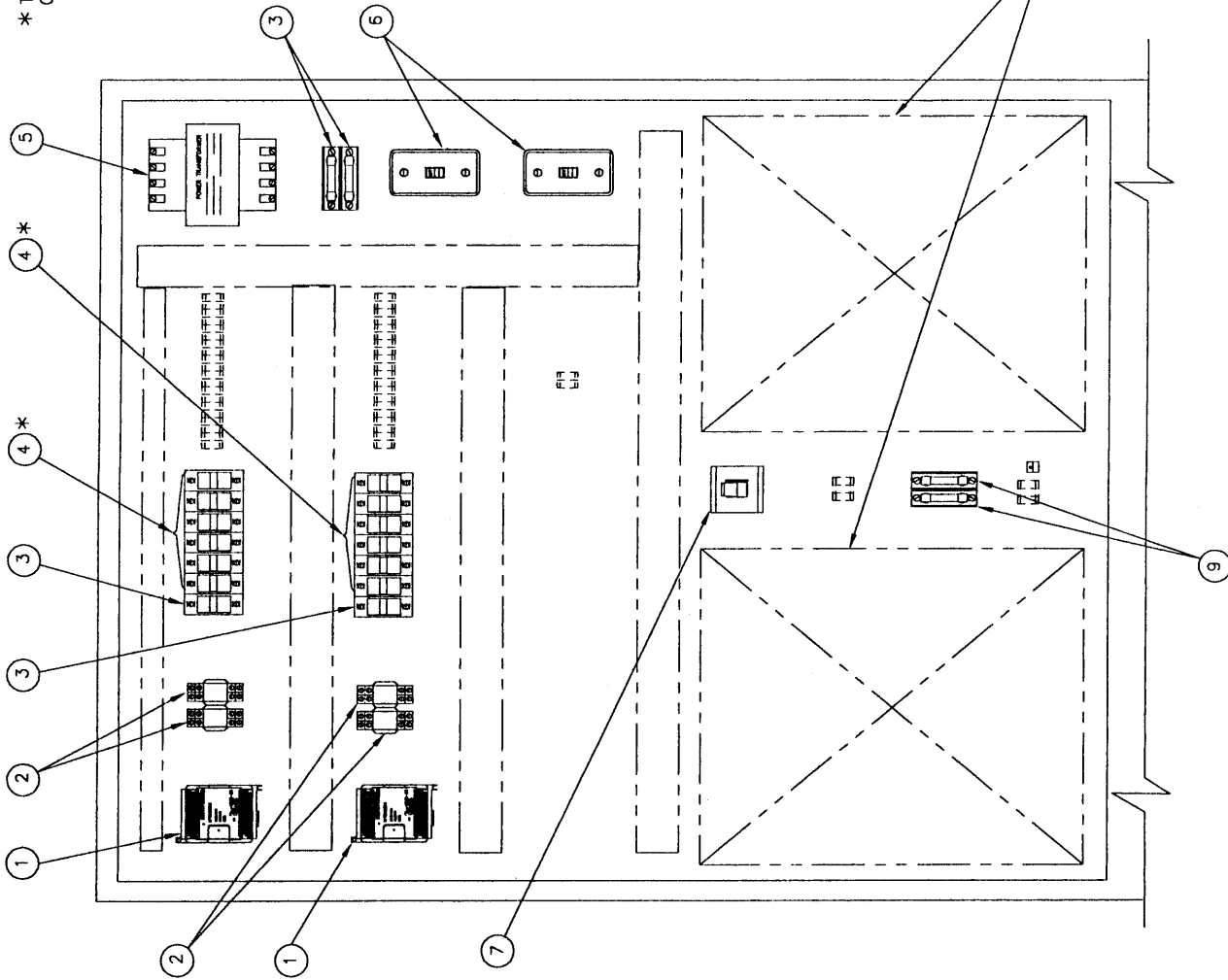

MOTOR HOOKUP DETAIL  
FOR MIXER KETTLES ONLY

FOR MIXER KETTLES SEE  
MOTOR HOOKUP DETAIL AND FOR  
PASTA KETTLE THERE IS NOTHING  
REQUIRED IN THIS AREA.

#15 IS ONLY FOR 60 & 100 GAL. KETTLES

ADDED #15	JES	6/01	INTERNAL DUAL CONTROL PANEL 2, 3 & 5HP	SIZE	C	DRAWING NUMBER	11632
DESCRIPTION	BY	DATE	208/230/380/460V HAK or TILT W/PASTA	REV.		SHEET	1 of 2
REVISIONS							

**J.C.PARDO & SONS INC.**  
1250 REAMES RD. BALTO MD. 21220  
PHONE (410) 391-3600 FAX (410) 391-9042

This drawing and all information contained therein is the property of J.C. Pardo & Sons, Inc., Balto, MD. The drawing shall not be reproduced, copied, or used in any way without the written consent of J.C. Pardo & Sons, Inc. It is hereby subject to return upon demand and is not to be used directly or indirectly in any way statements to J.C. Pardo & Sons.

UNIVERSAL REPLACEMENT PARTS		
ITEM	PART NO.	DESCRIPTION
1	ELBCO-0000046	PROGRAMMABLE CONTROLLER
2	ELPSW-0000002	RELAY
-	ELPSW-0000003	REPLACEMENT BASE FOR ITEM #2
3	ELV02-5000001	5 AMP FUSE
4	ELV02-5000002	1 AMP FUSE
5	----	TRANSFORMER BY SYSTEM VOLTAGE
-	ELV10-0000001	TRANSFORMER - 208/380V SYSTEM
-	ELV10-0000002	TRANSFORMER - 230/460V SYSTEM
6	ELPSW-0000007	LOW VOLTAGE DISCONNECT
7	ELPSW-0000001	HIGH VOLTAGE DISCONNECT
8	2EP00-0000001	FAN WITH SHROUDS
9	----	FUSES BY SYSTEM VOLTAGE
-	ELV06-0000002	8 AMP FUSE - 208V SYSTEM
-	ELV06-0000042	7 AMP FUSE - 230V SYSTEM
-	ELV06-0000019	5 AMP FUSE - 380V SYSTEM
-	ELV06-0000008	4 AMP FUSE - 460V SYSTEM
10	ELPSW-0000004	MOTOR CONTACTOR

OPTIONAL TILTING KETTLE PARTS		
ITEM	PART NO.	DESCRIPTION
11	ELPSW-0000005	HYDRAULIC MOTOR STARTER
-	ELV00-0000013	HEATER PACK FOR ITEM #9 208/230V
-	ELV00-0000023	HEATER PACK FOR ITEM #9 380/460V
12	ELV06-0000015	3 AMP FUSE

60 GAL. REPLACEMENT PARTS		
ITEM	PART NO.	DESCRIPTION
13	----	FUSES BY VOLTAGE
-	ELV06-0000007	20 AMP FUSE 208/230V
-	ELV06-0000010	10 AMP FUSE 380/460V
14	----	INVERTER BY VOLTAGE
-	ELH02-0000008	2 HP INVERTER, 208/230V
-	ELH02-0000009	2 HP INVERTER, 380/460V

100 GAL. REPLACEMENT PARTS		
ITEM	PART NO.	DESCRIPTION
13	----	FUSES BY VOLTAGE
-	ELV06-0000007	20 AMP FUSE 208/230V
-	ELV06-0000010	10 AMP FUSE 380/460V
14	----	INVERTER BY VOLTAGE
-	ELH03-0000010	3 HP INVERTER, 208/230V
-	ELH03-0000011	3 HP INVERTER, 380/460V

150/200 GAL. REPLACEMENT PARTS		
ITEM	PART NO.	DESCRIPTION
13	----	FUSES BY VOLTAGE
-	ELV06-0000018	30 AMP FUSE 208/230V
-	ELV06-0000004	15 AMP FUSE 380/460V
14	----	INVERTER BY VOLTAGE
-	ELH05-0000013	5 HP INVERTER, 208/230V
-	ELH05-0000014	5 HP INVERTER, 380/460V

60/100 GAL. REPLACEMENT PARTS		
ITEM	PART NO.	DESCRIPTION
15	----	LINE REACTORS BY VOLTAGE & HP
-	ELV00-0000024	LINE REACTOR 1-3HP 208/230/460V

REV. A	ADDED #15	JES	6/01
	DESCRIPTION	BY	DATE
REVISIONS			

**J.C. PARDO & SONS INC.**  
 1250 REAMES RD. BALTO MD. 21220  
 PHONE (410) 381-3600 FAX (410) 381-9042

DESIGNED BY: \_\_\_\_\_  
 APPROVED BY: \_\_\_\_\_  
 DATE: 10/23/01  
 SCALE: NONE

INTERNAL DUAL CONTROL PANEL 2, 3 & 5HP  
 208/230/380/460V HAK or TILT W/PASTA

DRAWING NUMBER: 11632  
 SHEET: C  
 2 of 2

of J.C. Pardo & Sons Inc. Bids for the design and engineering of all equipment for the above described project. All equipment shall be subject to our inspection and approval. Any equipment not approved by us shall be subject to our inspection and approval. Any equipment not approved by us shall be subject to our inspection and approval. Any equipment not approved by us shall be subject to our inspection and approval.

REPLACEMENT PARTS

ITEM	DESCRIPTION	PART NUMBER
1	TEE O-RING	SE30RING00011
2	TEE	1FS03-0000006
3	PLUNGER HEAD	1FS02-7500014
4	ACTUATOR BODY	ARS03-0000001
5	MALE QUICK DISCONNECT SST	ARS00-1200002
6	FEMALE QUICK DISCONNECT SST	ARS00-1200003
7	PLUNGER O-RING	SE30RING00012
8	FEMALE QUICK DISCONNECT BRASS	1HB00-1200002
9	AIR HOSE	AR700-2500002
10	MALE QUICK DISCONNECT BRASS	1HB00-1200001
11A	AIR SOLENOID 115 VOLT	AR800-2500013
-	REPLACEMENT COIL FOR ITEM #11A	SP988-8800027
11B	AIR SOLENOID 220 VOLT	AR800-2500014
-	REPLACEMENT COIL FOR ITEM #11B	SP988-8900028
-	REPAIR KIT FOR ITEM #11A & 11B	SP999-9900074
-	REPL. DINN CONN. FOR ITEM #11A & 11B	ELP00-0000032
12	AIR MUFFLER	ARP00-2500001
13	FLOW CONTROL AIR MUFFLER	ARB00-2500028
14	CLAMP	DFS03-0000001
15	O-RING	SE30RING00042

\*

\*CUSTOMER TO SPECIFY LENGTH.

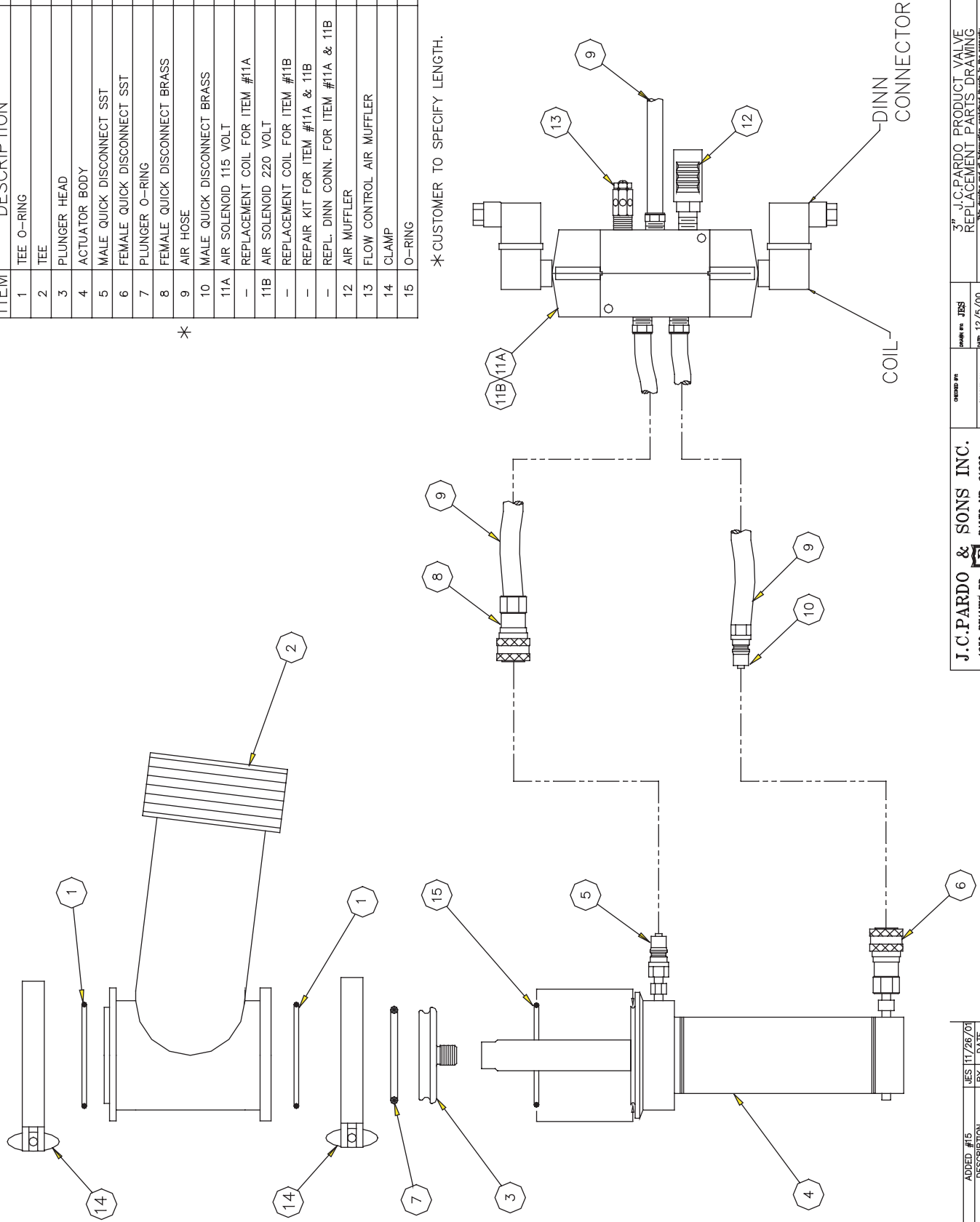

REV	ADDED #/5	DESCRIPTION	BY	DATE
A				JES 11/26/01

REVISIONS

**J.C. PARDO & SONS INC.**  
 10260 BELMONT RD. BALTO. MD. 21220  
 PHONE (410) 391-3800 FAX (410) 391-3800

QUOTED BY: JCS  
 DATE: 12/5/00  
 APPROVED BY: NONE

37 J.C. PARDO PRODUCT VALVE  
 REPLACEMENT PARTS DRAWING  
 THE INFORMATION CONTAINED HEREIN IS THE PROPERTY OF J.C. PARDO & SONS INC. IT IS TO BE USED ONLY FOR THE PURPOSES SPECIFIED AND IS NOT TO BE REPRODUCED, COPIED, OR TRANSMITTED IN ANY FORM OR BY ANY MEANS, ELECTRONIC OR MECHANICAL, INCLUDING PHOTOCOPYING, RECORDING, OR BY ANY INFORMATION STORAGE AND RETRIEVAL SYSTEM.

DRAWING NUMBER: D 11549  
 SHEET: A  
 1 of 1

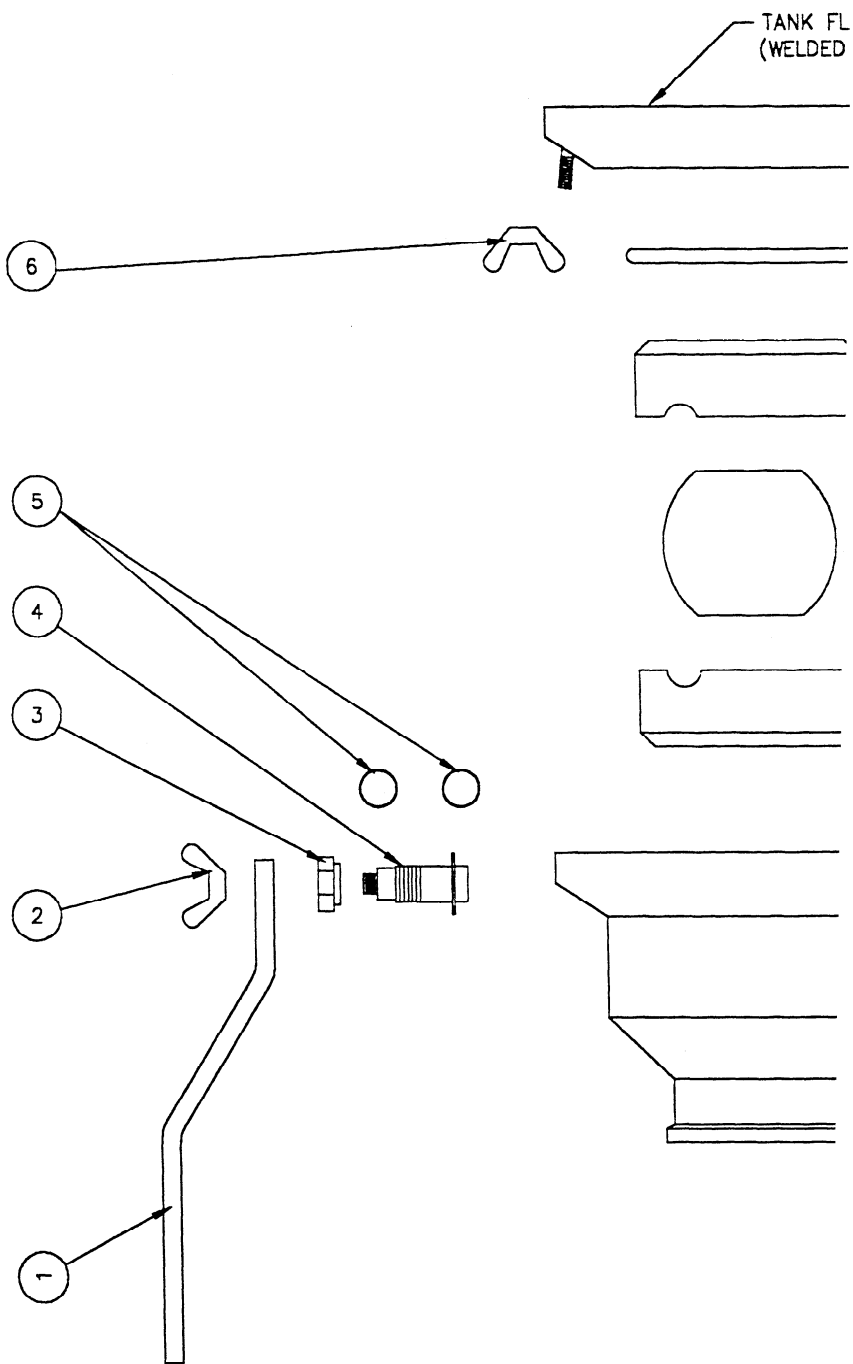

# REPLACEMENT PARTS

ITEM	PART NO.	DESCRIPTION
1	SPS03-0000005	HANDLE
2	HWS00-5000005	WING NUT 1/2-13
3	HWS00-0000002	PACKING NUT
4	SPS00-0000003	STEM
5	SPF00-0000001	STEM SEAL
6	HWS00-3800005	WING NUT 3/8-16
7	SPS03-0000004	VALVE BODY
8	SPF03-0000005	DISCHARGE SEAL
9	SPS03-0000006	BALL
10	SPF03-0000004	INTAKE SEAL
11	SE3ORING00008	O-RING

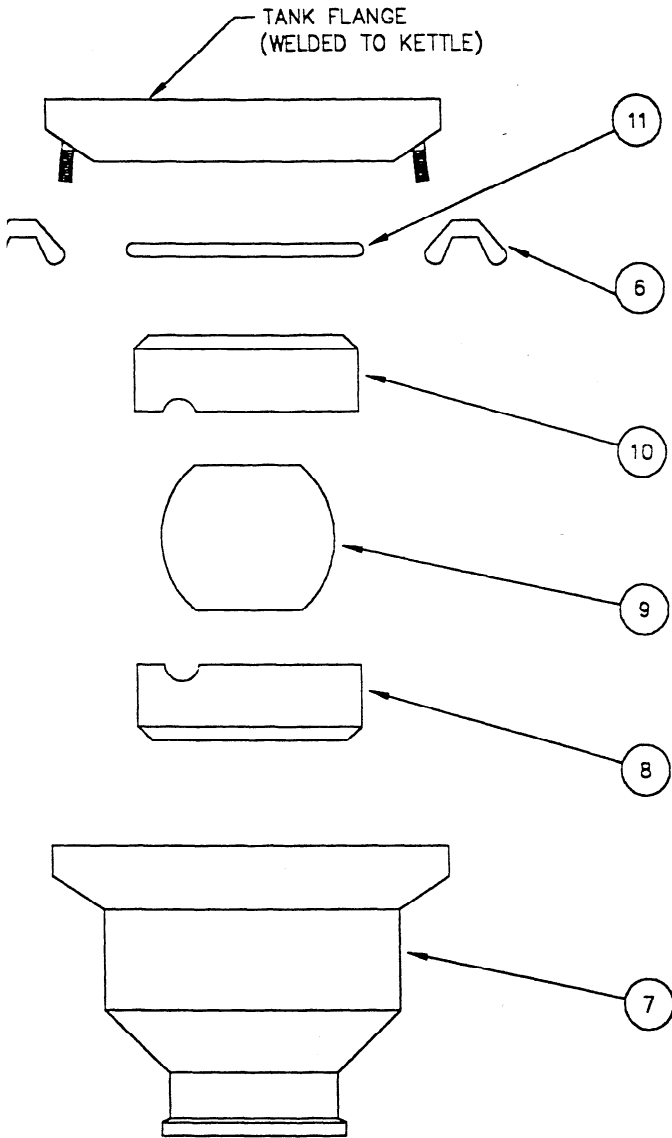

JOB #

<b>J.C. PARDO &amp; SONS INC.</b>			
1250 REAMES RD.			BALTO. MD. 21220
SCALE: NONE	APPROVED BY:	DRAWN BY:	
DATE: 7/21/95		LAURIE YORI	
3" LEE FLUSH TANK BALL VALVE REPLACEMENT PARTS			
SHEET 1 of 1	SIZE: C	DRAWING NUMBER: 11115	REV.

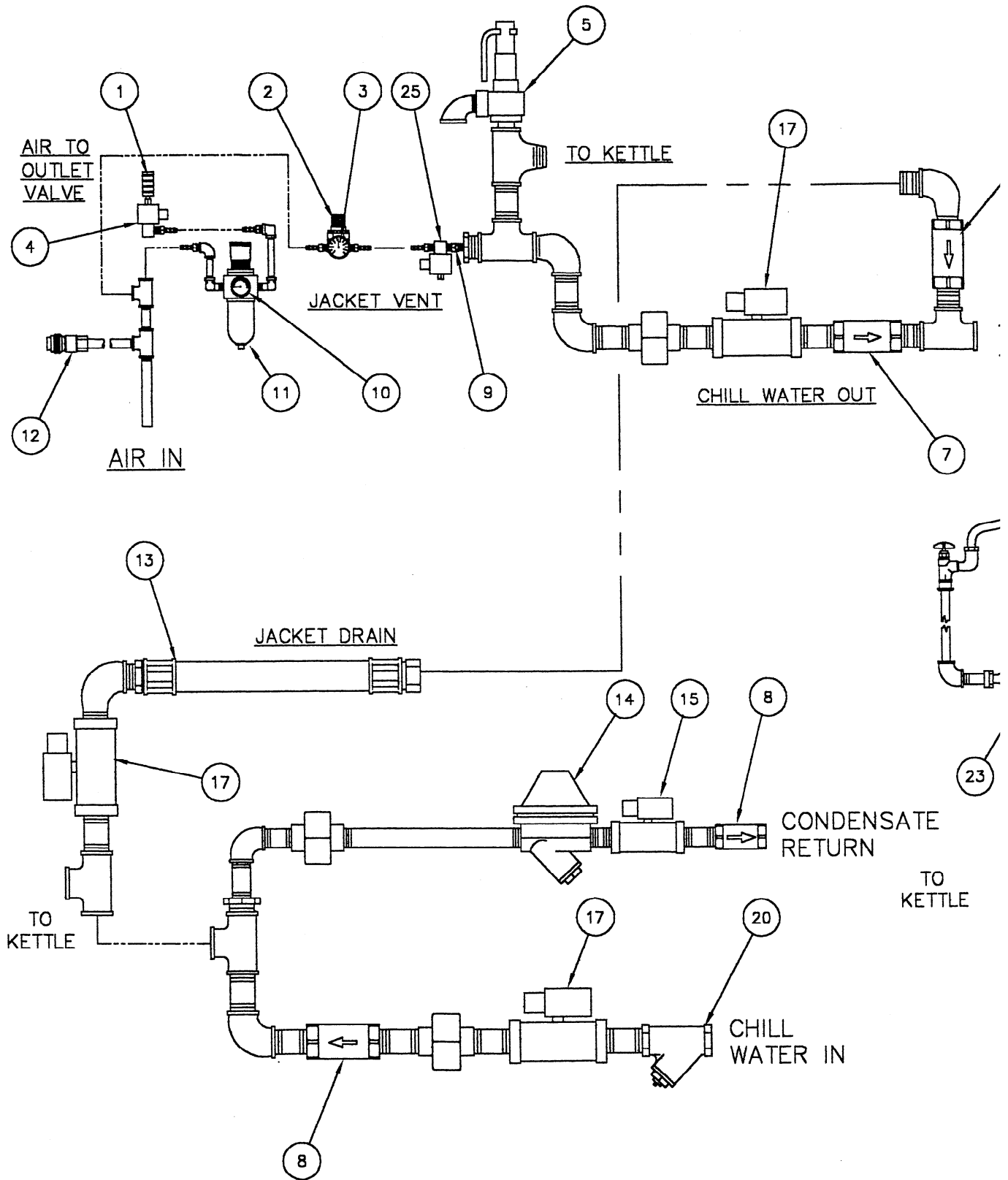

REV.	DESCRIPTION	BY	DATE
	REVISIONS		

**J.C.PARDO & SONS INC.**  
 1250 REAMES RD.  BALTO MD. 21220  
 PHONE (410) 391-3600 FAX (410) 391-8042

CHECKED BY:
APPROVED BY:

## REPLACEMENT PARTS LIST

ITEM	PART NO.	DESCRIPTION
1	ARP00-2500001	AIR MUFFLER
2	AR800-3700002	MINI AIR REGULATOR
3	AR800-2500002	REPLACEMENT GAUGE
4	ELB00-2500011	OUTLET VALVE SOLENOID
-	SP999-9900010	REPLACEMENT KIT FOR ITEM #4
-	SP988-8800004	REPLACEMENT COIL FOR ITEM #4
-	ELP00-0000000	REPLACEMENT DINN CONN. FOR ITEM #4
5	VAB00-7500005	50 PSI SAFETY VALVE
6	ELB00-5000015	POTABLE WATER IN SOLENOID
-	SP999-9900002	REPLACEMENT KIT FOR ITEM #6
-	SP988-8800002	REPLACEMENT COIL FOR ITEM #6
-	ELP00-0000000	REPLACEMENT DINN CONN. FOR ITEM #6
7	MSB00-7500004	BALL CONE CHECK VALVE
8	MSB00-5000005	BALL CONE CHECK VALVE
9	VAB00-2500001	NO LEAK CHECK VALVE
10	AR800-2500002	REPLACEMENT GAUGE
11	AR800-2500001	AIR REGULATOR
12	ARB00-5000001	AIR QUICK DISCONNECT
13	PBD00-7500001	JACKET DRAIN HOSE
14	MSC00-5000002	STEAM TRAP
-	SP999-9900017	REPAIR KIT FOR ITEM #14
15	ELB00-5000016	CONDENSATE SOLENOID
-	SP999-9900006	REPLACEMENT KIT FOR ITEM #15
-	SP988-8800003	REPLACEMENT COIL FOR ITEM #15
-	ELP00-0000000	REPLACEMENT DINN CONN. FOR ITEM #15
16	MSB00-5000001	50 MESH STRAINER
-	MSB00-5000006	REPLACEMENT SCREEN FOR ITEM #16
17	ELB00-7500015	JACKET DRAIN SOLENOID
-	SP999-9900004	REPLACEMENT KIT FOR ITEM #17
-	SP988-8800002	REPLACEMENT COIL FOR ITEM #17
-	ELP00-0000000	REPLACEMENT DINN CONN. FOR ITEM #17
18	PBS00-3800001	FLEXIBLE SIMMER LINE
19	ELB00-2500012	SIMMER SOLENOID
-	SP999-9900009	REPLACEMENT KIT FOR ITEM #19
-	SP988-8800003	REPLACEMENT COIL FOR ITEM #19
-	ELP00-0000000	REPLACEMENT DINN CONN. FOR ITEM #19
20	MSB00-7500001	50 MESH STRAINER
-	MSB00-7500006	REPLACEMENT SCREEN FOR ITEM #20
21	ELB00-7500016	STEAM IN SOLENOID
-	SP999-9900007	REPLACEMENT KIT FOR SOLENOID #21
-	SP988-8800003	REPLACEMENT COIL FOR SOLENOID #21
-	ELP00-0000000	REPLACEMENT DINN CONN. FOR ITEM #21
22	PBB00-5000024	FILL FAUCET
23	ELB00-5000002	WATER METER UNIT
-	EL977-7700001	REPLACEMENT RESISTOR FOR ITEM #23
-	EL977-7700011	REPLACEMENT REED SWITCH FOR ITEM #23
24	MSB00-3800001	BALL CONE CHECK VALVE
25	ELB00-2500013	JACKET VENT SOLENOID
-	SP999-9900064	REPLACEMENT KIT FOR ITEM #25
-	SP988-8800002	REPLACEMENT COIL FOR ITEM #25
-	ELP00-0000000	REPLACEMENT DINN CONN. FOR ITEM #25

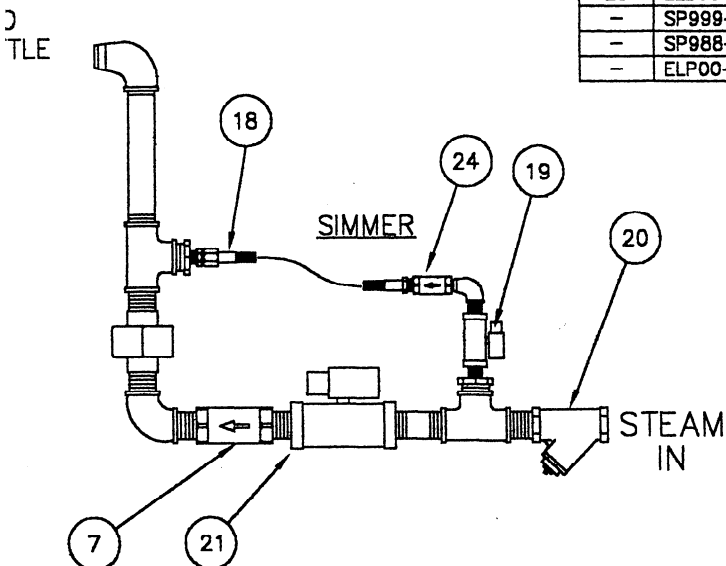
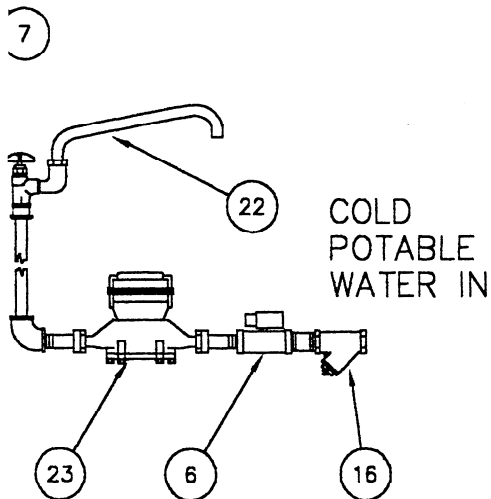
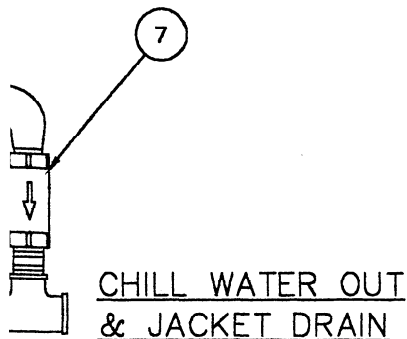

BY:	DRAWN BY: JAY S.	60-HAK PLUMBING W/DINN CONN. REPLACEMENT PARTS	SIZE:	DRAWING NUMBER:
	DATE: 2/4/00		C	11524
BY:	SCALE: NONE	This drawing and all information contained therein is the property of J.C. Perdo & Sons Inc. Balto MD. The drawing and all information is confidential and must not be made public or copied. It is loaned subject to return upon demand and is not to be used directly or indirectly in any way detrimental to J.C. Perdo & Sons.	REV.	SHEET
				1 of 1

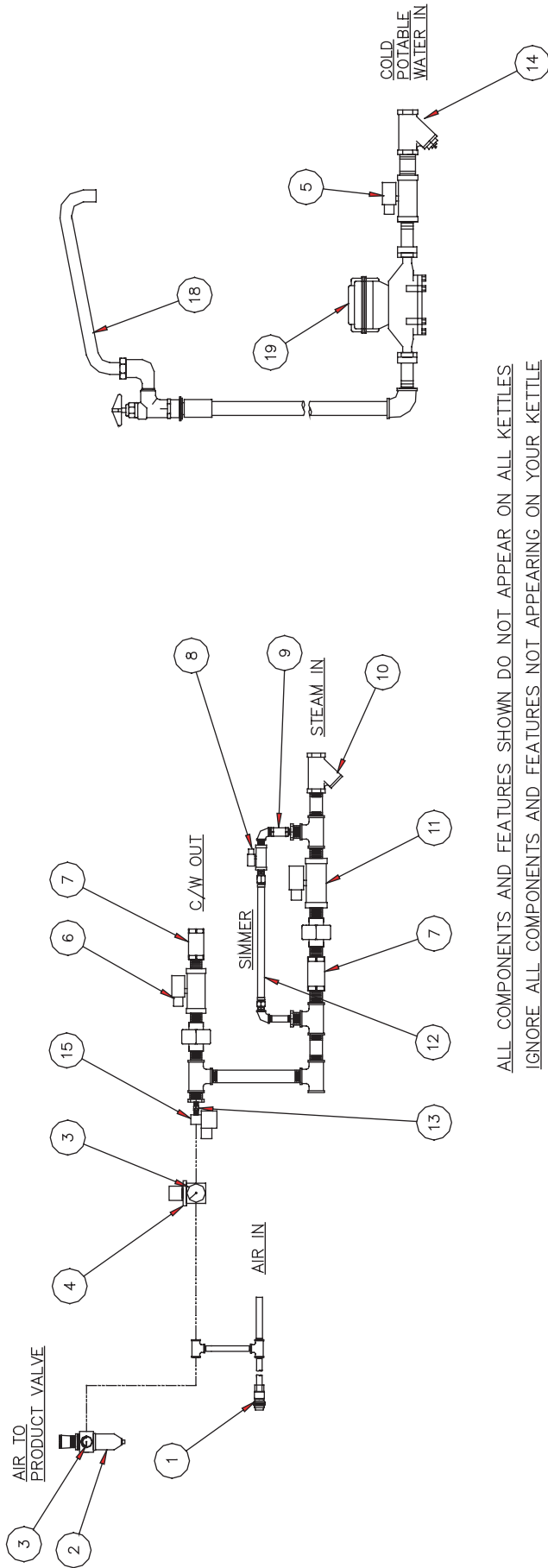

ALL COMPONENTS AND FEATURES SHOWN DO NOT APPEAR ON ALL KETTLES  
 IGNORE ALL COMPONENTS AND FEATURES NOT APPEARING ON YOUR KETTLE

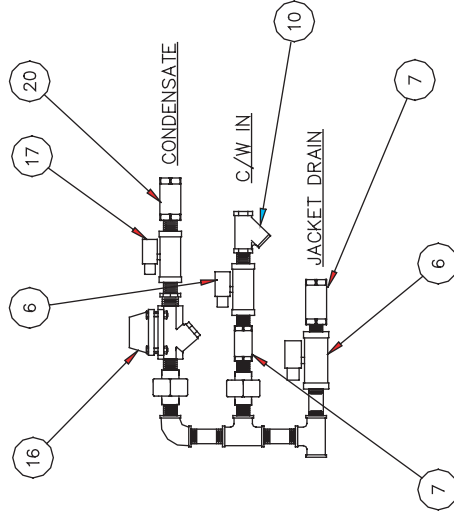

OPTIONAL HOT/COLD POTABLE WATER

REV.	DESCRIPTION	BY	DATE
	REVISIONS		

**J.C. PARDO & SONS INC.**  
 1250 REAMES RD. BALTO MD. 21220  
 PHONE (410) 381-3600 FAX (410) 381-3600

ORDER # JCSI  
 DATE 6-29-01  
 APPROV # NONE

MODEL NUMBER  
 D 11628  
 SHEET  
 1 OF 2

ALL COMPONENTS AND FEATURES SHOWN DO NOT APPEAR ON ALL KETTLES  
 IGNORE ALL COMPONENTS AND FEATURES NOT APPEARING ON YOUR KETTLE

ITEM	PART NO.	DESCRIPTION
1	ARB00-5000001	QUICK DISCONNECT
2	AR800-2500001	AIR FILTER REGULATOR
3	AR800-2500004	REPLACEMENT GAUGE
4	AR800-2500003	MINI AIR REGULATOR
5	ELB00-7500015	SOLENOID, POTABLE WATER IN
-	SP999-9900004	REPLACEMENT KIT FOR ITEM #5
-	SP988-8800002	REPLACEMENT COIL FOR ITEM #5
-	ELP00-0000000	REPLACEMENT DINN CONN. FOR ITEM #5
6	ELB01-2500011	SOL. CHILL WATER IN/OUT & JACKET DR.
-	SP999-9900005	REPLACEMENT KIT FOR ITEM #6
-	SP988-8800002	REPLACEMENT COIL FOR ITEM #6
-	ELP00-0000000	REPLACEMENT DINN CONN. FOR ITEM #6
7	MSB01-2500004	BALL CONE CHECK VALVE
8	ELB00-5000016	SOLENOID, SIMMER
-	SP999-9900006	REPLACEMENT KIT FOR ITEM #8
-	SP988-8800003	REPLACEMENT COIL FOR ITEM #8
-	ELP00-0000000	REPLACEMENT DINN CONN. FOR ITEM #8
9	MSB00-5000005	BALL CONE CHECK VALVE
10	MSB01-2500001	STRAINER
-	MSB01-2500005	REPLACEMENT SCREEN FOR ITEM #10

ITEM	PART NO.	DESCRIPTION
11	ELB01-2500012	SOLENOID, STEAM IN
-	SP999-9900008	REPLACEMENT KIT FOR ITEM #11
-	SP988-8800003	REPLACEMENT COIL FOR ITEM #11
-	ELP00-0000000	REPLACEMENT DINN CONN. FOR ITEM #11
12	PBS00-5000026	FLEXIBLE SST BRAIDED HOSE
13	VAB00-2500001	NO LEAK CHECK VALVE
14	MSB00-7500001	STRAINER
-	MSB00-7500006	REPLACEMENT SCREEN FOR ITEM #14
15	ELB00-25000013	SOLENOID, JACKET VENT
-	SP999-9900064	REPLACEMENT KIT FOR ITEM #15
-	SP988-8800002	REPLACEMENT COIL FOR ITEM #15
-	ELP00-0000000	REPLACEMENT DINN CONN. FOR ITEM #15
16	MSC00-7500002	STEAM TRAP
-	SP999-9900017	REPLACEMENT KIT FOR ITEM #16
17	ELB01-0000014	SOLENOID, CONDENSATE
-	SP999-9900008	REPLACEMENT KIT FOR ITEM #17
-	SP988-8800003	REPLACEMENT COIL FOR ITEM #17
-	ELP00-0000000	REPLACEMENT DINN CONN. FOR ITEM #17
18	PBB00-7500018	FILL FAUCET
-	PBB00-7500021	REPLACEMENT SWING SPOUT FOR ITEM #18
19	ELB00-7500017	DIGITAL COLD WATER METER
20	MSB01-0000003	BALL CONE CHECK VALVE
21	ELB00-7500018	DIGITAL HOT WATER METER (OPTIONAL)

A	#12 WAS PBF00-5000001	JES	7/03
REV.	DESCRIPTION	BY	DATE
REVISIONS			

**J.C. PARDO & SONS INC.**  
 1250 REAMES RD.  
 BALTO MD. 21220  
 PHONE (410) 391-3600  
 FAX (410) 391-3600

ORDER #:  
 DATE: 6-29-01  
 APPROVED BY:  
 NONE

HAMK-DL-150-200-T PLUMBING W/DINN  
 CONNECTORS REPLACEMENT PARTS  
 21 REPLACEMENT KIT FOR ITEM #11  
 22 REPLACEMENT COIL FOR ITEM #11  
 23 REPLACEMENT DINN CONN. FOR ITEM #11  
 24 FLEXIBLE SST BRAIDED HOSE  
 25 NO LEAK CHECK VALVE  
 26 STRAINER  
 27 REPLACEMENT SCREEN FOR ITEM #14  
 28 SOLENOID, JACKET VENT  
 29 REPLACEMENT KIT FOR ITEM #15  
 30 REPLACEMENT COIL FOR ITEM #15  
 31 REPLACEMENT DINN CONN. FOR ITEM #15  
 32 STEAM TRAP  
 33 REPLACEMENT KIT FOR ITEM #16  
 34 SOLENOID, CONDENSATE  
 35 REPLACEMENT KIT FOR ITEM #17  
 36 REPLACEMENT COIL FOR ITEM #17  
 37 REPLACEMENT DINN CONN. FOR ITEM #17  
 38 FILL FAUCET  
 39 REPLACEMENT SWING SPOUT FOR ITEM #18  
 40 DIGITAL COLD WATER METER  
 41 BALL CONE CHECK VALVE  
 42 DIGITAL HOT WATER METER (OPTIONAL)

ORDER NUMBER:  
 11628  
 REV: D  
 PAGE: 2 of 2

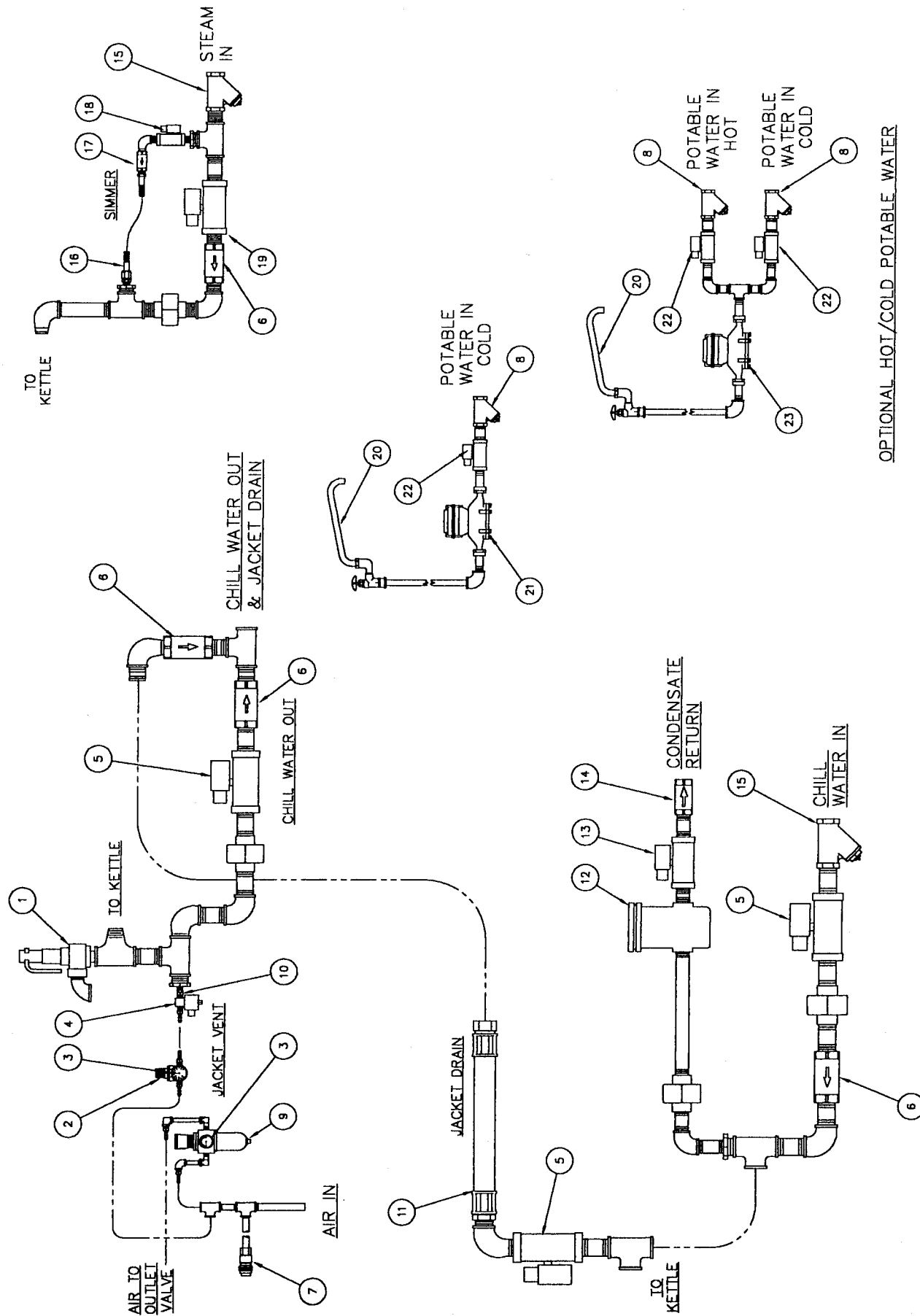

OPTIONAL HOT/COLD POTABLE WATER

REV.	DESCRIPTION	BY	DATE	REVISIONS
<b>J.C. PARDO &amp; SONS INC.</b> 1250 REAMES RD. BALTO MD. 21220 PHONE (410) 381-3000 FAX (410) 381-9043				
DESIGNED BY	DATE BY JES	DATE 4/1/02	SCALE NONE	
APPROVED BY	MKDL-300-CC PLUMBING W/DINN CONNECTORS REPLACEMENT PARTS			
	QTY	UNIT	QTY	UNIT
			11658	1 of 2

ITEM	PART NO.	DESCRIPTION
1	VAB01-2500001	100 PSI SAFETY VALVE
2	ARB00-3700002	MINI AIR REGULATOR
3	ARB00-2500004	REPLACEMENT GAUGE
4	ELB00-2500013	JACKET VENT SOLENOID
-	ELP00-0000000	REPLACEMENT DINN CONN. FOR ITEM #4
-	SP999-9900064	REPLACEMENT KIT FOR ITEM #4
-	SP988-8800002	REPLACEMENT COIL FOR ITEM #4
5	ELB01-5000006	CHILL WATER IN/OUT & JACKET DRAIN SOL.
-	ELP00-0000000	REPLACEMENT DINN CONN. FOR ITEM #5
-	SP999-9900014	REPLACEMENT KIT FOR ITEM #5
-	SP988-8800002	REPLACEMENT COIL FOR ITEM #5
6	MSB01-5000004	BALL CONE CHECK VALVE
7	ARB00-5000001	AIR QUICK DISCONNECT
8	MSB00-7500001	50 MESH STRAINER
-	MSB00-7500006	REPLACEMENT SCREEN FOR ITEM #8
9	ARB00-2500015	AIR REGULATOR
10	VAB00-2500001	NO LEAK CHECK VALVE
11	PBD01-5000006	JACKET DRAIN HOSE
12	MSC00-7500007	STEAM TRAP
-	SP999-9900018	REPAIR KIT FOR ITEM #12
13	ELB01-0000014	CONDENSATE SOLENOID
-	ELP00-0000000	REPLACEMENT DINN CONN. FOR ITEM #13
-	SP999-9900008	REPLACEMENT KIT FOR ITEM #13
-	SP988-8800003	REPLACEMENT COIL FOR ITEM #13

ITEM	PART NO.	DESCRIPTION
14	MSB01-0000003	BALL CONE CHECK VALVE
15	MSB01-5000001	50 MESH STRAINER
-	MSB01-5000003	REPLACEMENT SCREEN FOR ITEM #15
16	PBF00-7500001	SIMMER FLEX LINE
17	MSB00-7500005	BALL CONE CHECK VALVE
18	ELB00-7500016	SIMMER SOLENOID
-	ELP00-0000000	REPLACEMENT DINN CONN. FOR ITEM #18
-	SP999-9900007	REPLACEMENT KIT FOR ITEM #18
-	SP988-8800003	REPLACEMENT COIL FOR ITEM #18
19	ELB01-5000007	STEAM IN SOLENOID
-	ELP00-0000000	REPLACEMENT DINN CONN. FOR ITEM #19
-	SP999-9900013	REPLACEMENT KIT FOR ITEM #19
-	SP988-8800003	REPLACEMENT COIL FOR ITEM #19
20	PBB00-7500018	FILL FAUCET
21	ELB00-7500017	DIGITAL COLD WATER METER
22	ELB00-7500015	POTABLE WATER IN SOLENOID
-	ELP00-0000000	REPLACEMENT DINN CONN. FOR ITEM #22
-	SP999-9900004	REPLACEMENT KIT FOR SOLENOID #22
-	SP988-8800002	REPLACEMENT COIL FOR SOLENOID #22
23	ELB00-7500018	DIGITAL HOT WATER METER (OPTIONAL)

REPLACEMENT PARTS LIST

REPLACEMENT PARTS LIST

REV.	DESCRIPTION	BY	DATE	<p><b>J.C.PARDO &amp; SONS INC.</b>          1250 REAMERS RD. BALTO MD. 21220          PHONE (410) 391-3600 FAX (410) 391-9043</p>	<p>CREATED BY: JES          DATE: 4/1/02          DRAWN BY: NONE</p>	<p>PROJECT: MKDL-300-CC PLUMBING W/DINN CONNECTORS REPLACEMENT PARTS</p>	<p>ISSUE: 11658</p>	<p>REV: C</p>	<p>2 of 2</p>
<p>REVISIONS</p>									

THESE PARTS ARE THE PROPERTY OF J.C. PARDO & SONS INC. NO PARTS ARE TO BE REPRODUCED OR COPIED IN ANY MANNER WITHOUT THE WRITTEN PERMISSION OF J.C. PARDO & SONS INC. THIS DOCUMENT IS ONLY VALID FOR THE PROJECT AND SITE SPECIFICALLY LISTED HEREIN. IT IS NOT TO BE REPRODUCED OR COPIED IN ANY MANNER WITHOUT THE WRITTEN PERMISSION OF J.C. PARDO & SONS INC.

REPLACEMENT PARTS

ITEM	PART NO.	DESCRIPTION
1	ELC00-0000011	WIRE RESTRAINT
2	TSENSOR000001	CAP ASSEMBLY
3	DFS02-0000002	2 TRI CLAMP
4	SE3ORING00004	OUTER O-RING
5	SRSENSOR00001	SEAL RETAINER
6	SE3ORING00005	INNER O-RING
7	TSENSOR00002	TEMPERATURE SENSOR

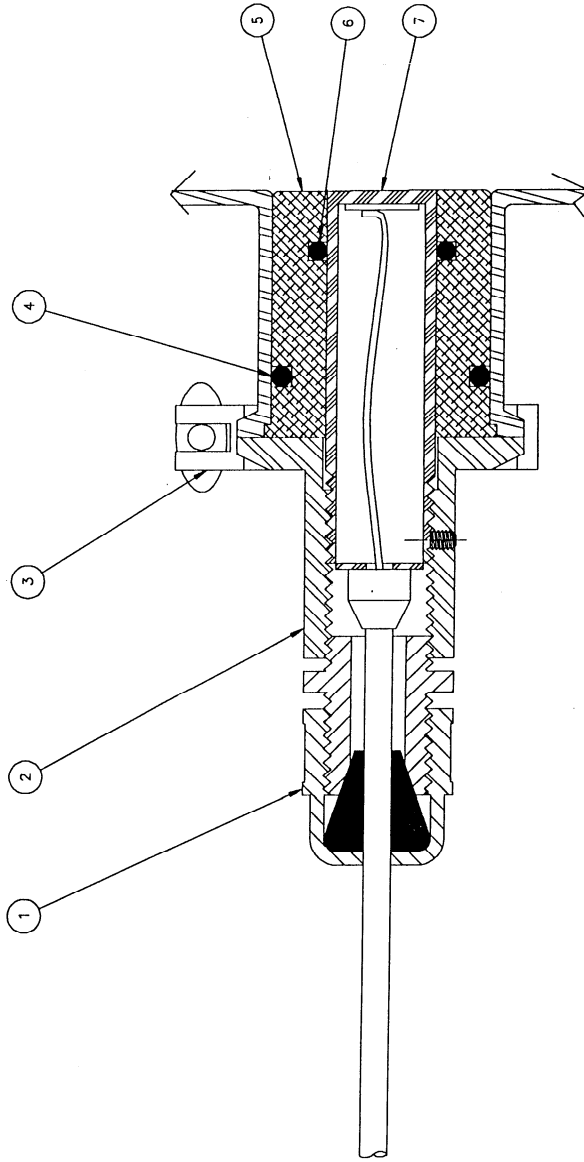

**J.C.PARDO & SONS INC.**  
 1250 REAMES RD. BALTO. MD. 21220

SCALE NONE  
 DATE 9-15-94  
 DRAWN BY TJK  
 CHECKED BY TJK  
 APPROVED BY TJK

TEMPERATURE SENSOR WITH  
 PART NO# R1D SENSOR

SHEET 1 OF 1

REVI.	DESCRIPTION	BY	DATE
A	REDR. FROM B-5413	TJK	9/15/94

REVISIONS

# REPLACEMENT PARTS

ITEM	PART NO.	DESCRIPTION
1	ELC00-0000011	WIRE RESTRAINT
2	TSENSOR000001	CAP ASSEMBLY
3	DFS02-0000002	2" TRI CLAMP
4	SE3ORING00004	OUTER O-RING
5	SRSENSOR00001	SEAL RETAINER
6	SE3ORING00005	INNER O-RING
7	TSENSOR000007	TEMPERATURE SENSOR

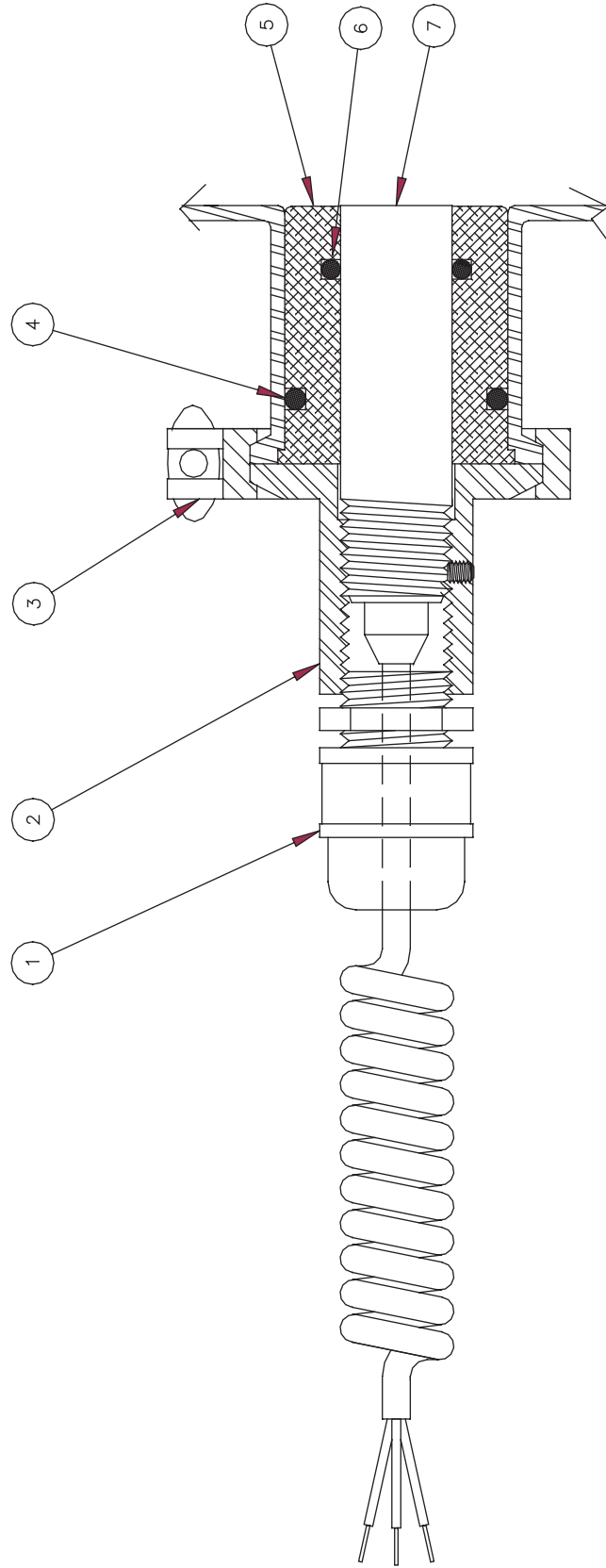

REV.	DESCRIPTION	BY	DATE	REVISIONS
<b>J.C.PARDO &amp; SONS INC.</b> 1250 REAMES RD. BALTO MD. 21220 PHONE (410) 391-3600 FAX (410) 391-6042				CHECKED BY: APPROVED BY:
DRAWN BY: LY DATE: 2/13/95 SCALE: NONE				TEMPERATURE SENSOR W/RETRACTABLE CABLE REPLACEMENT PARTS
THIS DRAWING AND ALL INFORMATION CONTAINED HEREIN ARE THE PROPERTY OF J.C.PARDO & SONS INC. THIS DRAWING AND ALL INFORMATION CONTAINED HEREIN IS UNCLASSIFIED AND MUST NOT BE MADE PUBLIC OR COPIED, REPRODUCED, OR TRANSMITTED IN ANY FORM OR BY ANY MEANS, ELECTRONIC OR MECHANICAL, INCLUDING PHOTOCOPYING, RECORDING, OR BY ANY INFORMATION STORAGE AND RETRIEVAL SYSTEM, WITHOUT THE WRITTEN PERMISSION OF J.C.PARDO & SONS INC.				SIZE: C REV. 1 of 1
				DRAWING NUMBER: 11077

ITEM	DESCRIPTION	PART NO.
1	HINGE BASE	FPHINGS00002
2	BRONZE BEARING	BGZ00-000001
3	HINGE BODY	FPHINGS00001
4	SPRING	MSSPRING00004
5	CENTERING ROD	FPHINGS00003
6	LOCK HUB/BEARING	BGZ00-000002
7	END PLATE	FPHINGS00004
8	CAP SCREW	HWS00-1900001
9	CAP SCREW	HWS00-2500006
10	COMPLETE HINGE	ACCOVERS00002

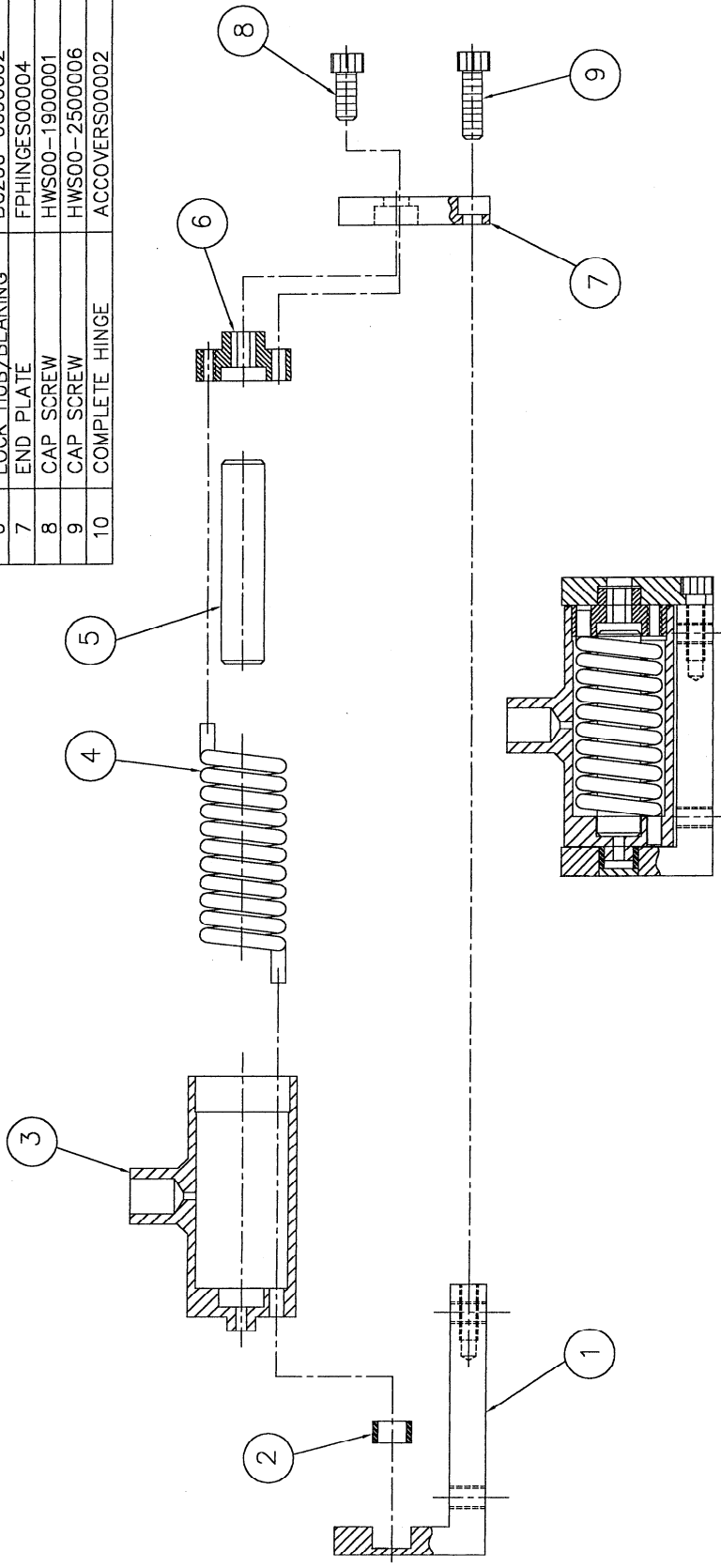

REV.	DESCRIPTION	BY	DATE
A	REDRAWN IN ACAD	SME	4/24/00
REVISIONS			

**J.C.PARDO & SONS INC.**

CHECKED BY: \_\_\_\_\_ APPROVED BY: \_\_\_\_\_

DRAWN BY: JS  
 DATE: 8-21-94  
 SCALE: NONE

UNLESS NOTED OTHERWISE TOLERANCES ARE:  
 .XX = ±  
 .XXX = ±  
 FRACT. = ±  
 ANGLE = ±  
 FINISH =  
 RMS

**HINGE/ACTUATOR ASSEMBLY & REPLACEMENT PARTS DETAIL**

This drawing and all information contained therein is the property of J.C.Pardo & Sons Inc., Balto Md. The drawing and all information contained herein must be made public or copied in its entirety without the written consent of J.C.Pardo & Sons. directly or indirectly in any way detrimental to J.C.Pardo & Sons.

JOB#: \_\_\_\_\_ QTY: \_\_\_\_\_

SIZE: B  
 DRAWING NUMBER: 8539  
 REV: A  
 SHEET: 1 of 1

ITEM	DESCRIPTION	PART NO.
1	HINGE BASE	FAHGES00001
2	BRONZE BEARING	BGZ00-7500001
3	HINGE BODY	FAHGES00002
4	SPRING	MSSPRING00001
5	CENTERING ROD	FAHGES00003
6	LOCK HUB/BEARING	BGZ01-6500001
7	END PLATE	FAHGES00004
8	CAP SCREW	HWS00-2500003
9	CAP SCREW	HWS00-3100001
10	COMPLETE HINGE	ACCOVERS00001

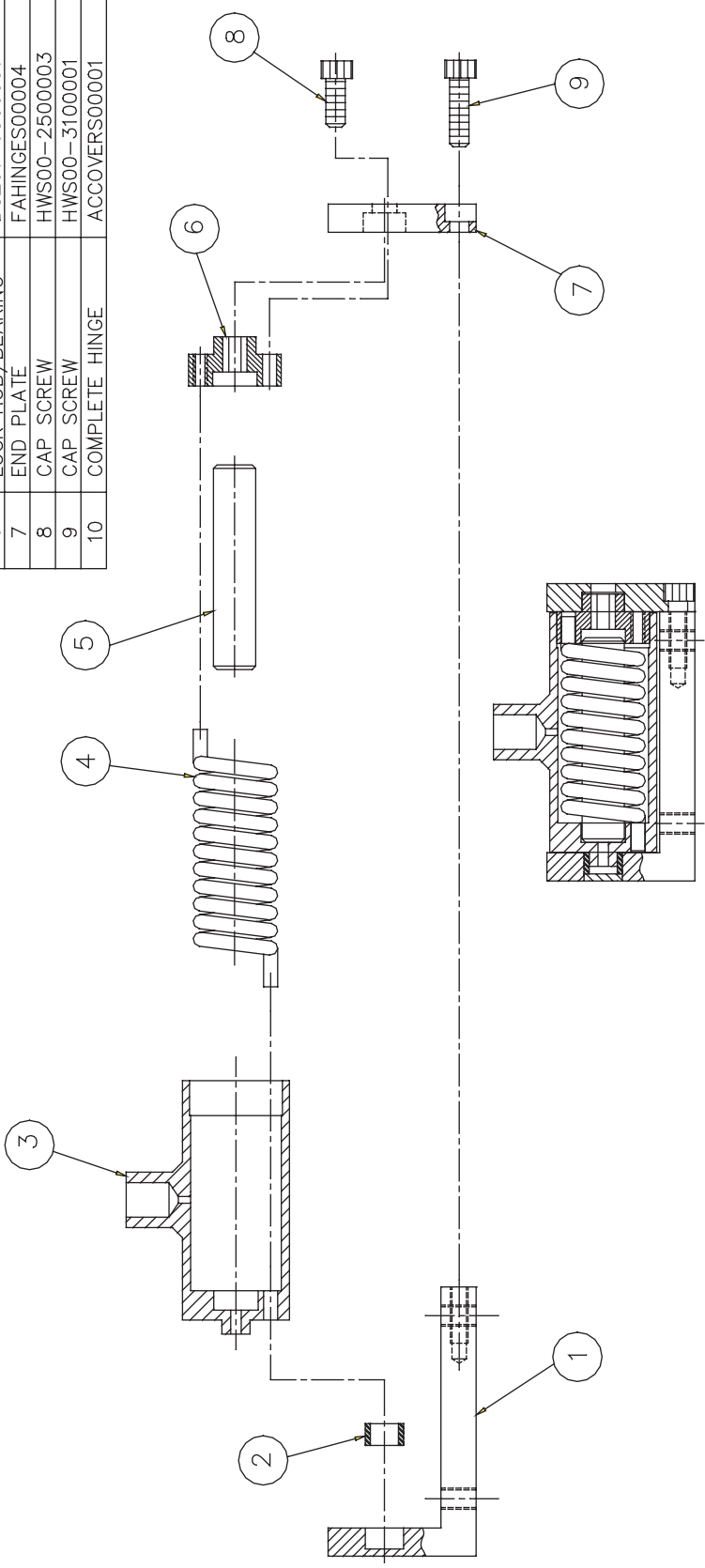

A	REDRAWN IN ACAD	JES	4/3/01
REV.	DESCRIPTION	BY	DATE
REVISIONS			

**J.C.PARDO & SONS INC.**  
 1250 REAMES RD. BALTO MD. 21220  
 PHONE (410) 391-9600 FAX (410) 391-9042

CHECKED BY:	DRAWN BY: JES
APPROVED BY:	DATE: 7-30-93
	SCALE: NONE

150-200 GAL HINGE/ACTUATOR  
 REPLACEMENT PARTS

SIZE:	B	DRAWING NUMBER:	8415
REV.	A	SHEET	1 of 1

This drawing and all information contained therein is the property of J.C.Pardo & Sons, Inc., Balto, MD. The drawing and all information is confidential and must not be made public or copied, loaned, or otherwise disseminated without the written consent of J.C.Pardo & Sons, Inc. Failure to do so may result in legal action.

10 HINGE ASSY.

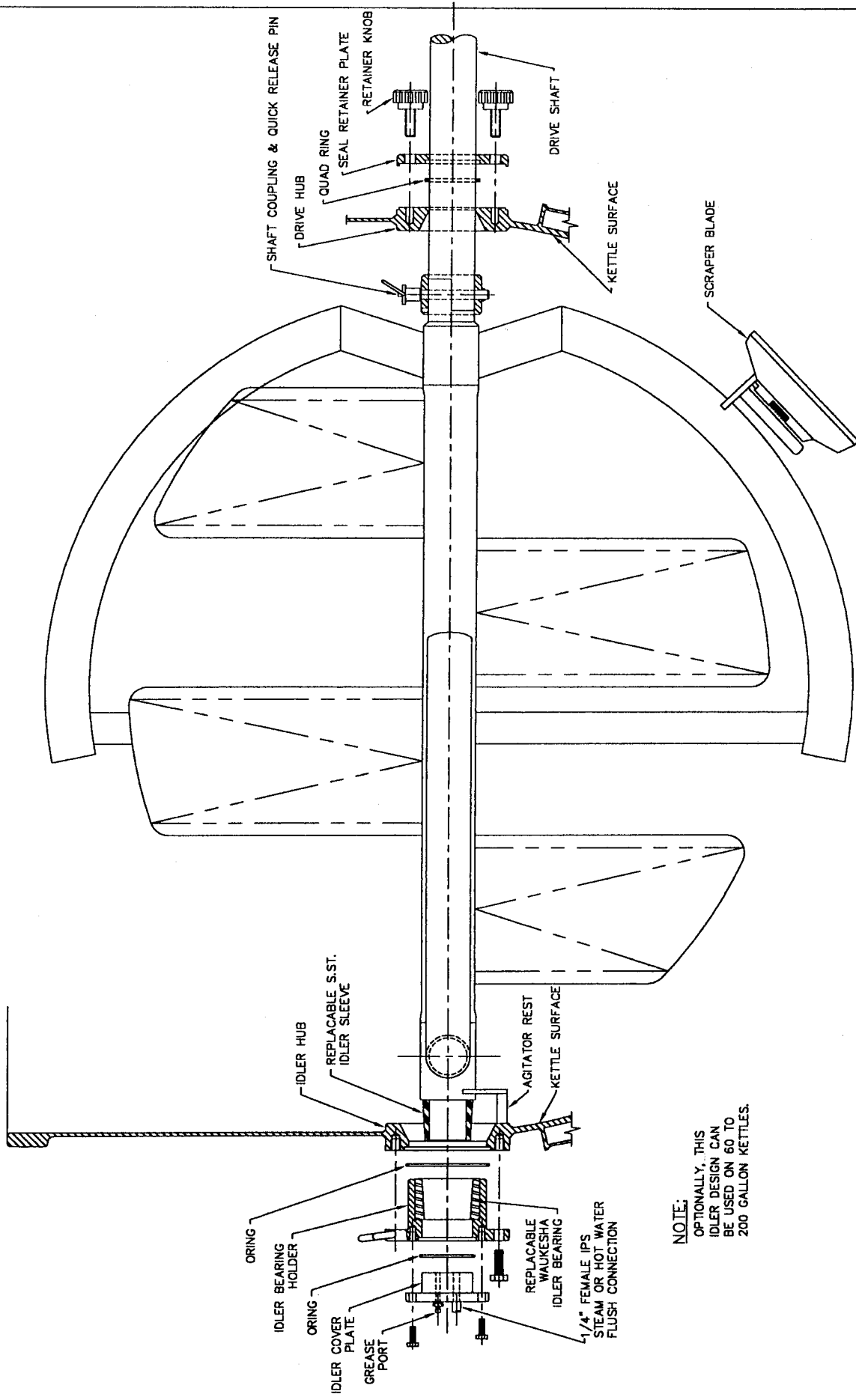

NOTE:  
 OPTIONALLY, THIS  
 IDLER DESIGN CAN  
 BE USED ON 60 TO  
 200 GALLON KETTLES.

REV.	DESCRIPTION	BY	DATE	<b>J.C. PARDO &amp; SONS INC.</b> 1250 REAMES RD. BALTO MD. 21220 PHONE (410) 381-3800 FAX (410) 381-9042		ORDER NO. APPROVED BY	DRAWN BY: JAY S. DATE: 9/21/00 MADE NONE	PART NUMBER: <b>8990</b> PART	SHEET <b>1 of 2</b>
REVISIONS				<b>300-HAK CLEANING DETAIL          IDLER AND DRIVE HUB</b> <small>This drawing and all information contained therein is the property of J.C. Pardo &amp; Sons, Inc. No part of it may be reproduced, stored in a retrieval system, or transmitted in any form or by any means, electronic, mechanical, photocopying, recording, or otherwise, without the prior written permission of J.C. Pardo &amp; Sons, Inc.</small>					

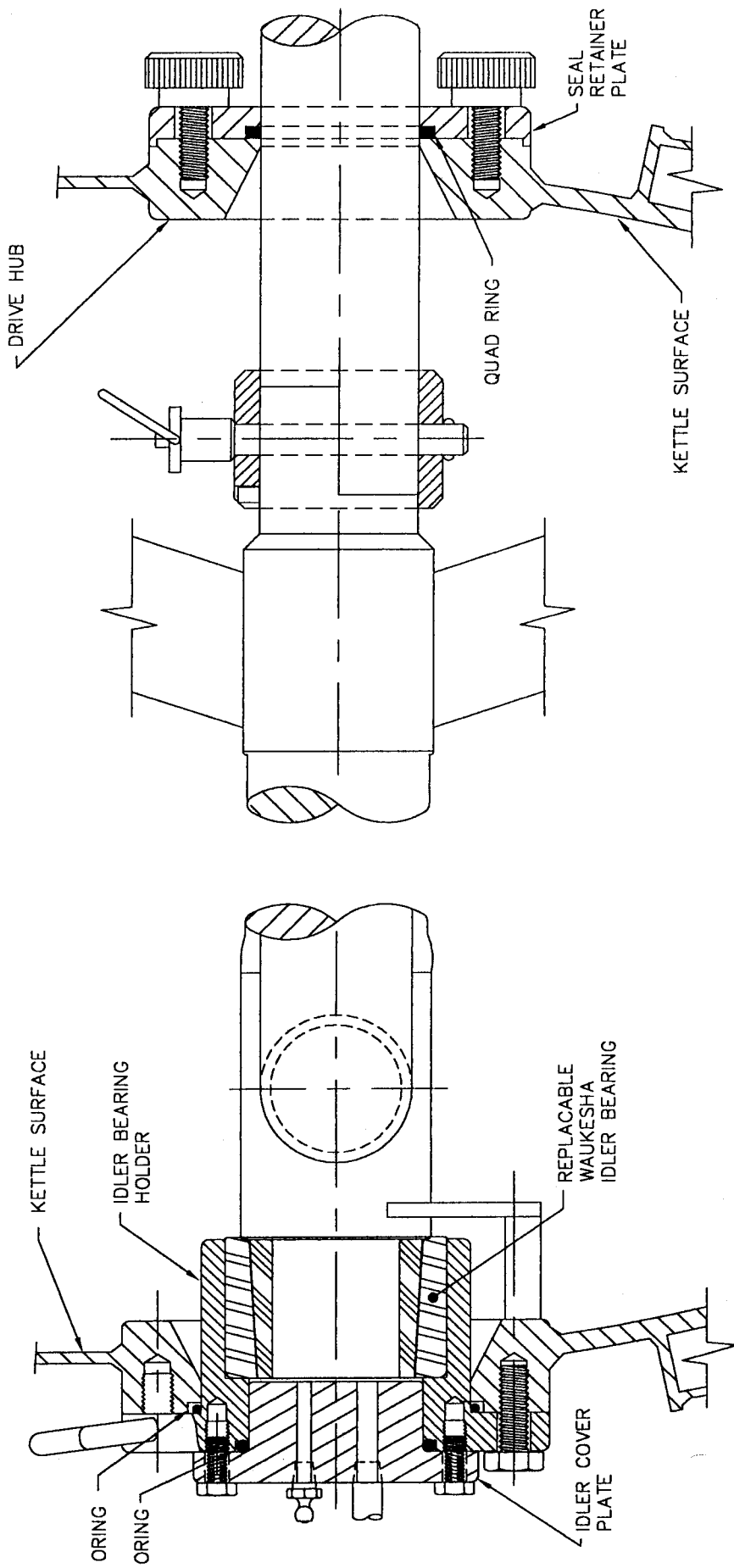

IDLER END

DRIVE END

**J.C.PARDO & SONS INC.**  
 1250 REAMES RD. BALTO MD. 21220  
 PHONE (410) 391-3600 FAX (410) 391-8042

CHECKED BY:  
 APPROVED BY:

DRAWN BY: SE  
 DATE: 9/21/00  
 SCALE: NONE

300-HAK CLEANING DETAIL  
 IDLER & DRIVE HUB ASSEMBLY

This drawing and all information contained therein is the property of J.C.Pardo & Sons, Inc. Balto, MD. The drawing and all information is confidential and must not be made public or copied, reproduced, or used in any way without the prior written consent of J.C.Pardo & Sons.

SIZE: B  
 DRAWING NUMBER: 8990  
 REV. SHEET  
 2 of 2



# REPLACEMENT PARTS LIST

ITEM	PART NO.	DESCRIPTION
1	SETSEALS00002	TEFLON SEAL
2	MSSPRING00006	SPRING
3	MSSPRING00011	SPRING SEAT
4	MSC01-2500001	1 1/4" BARCO JOINT

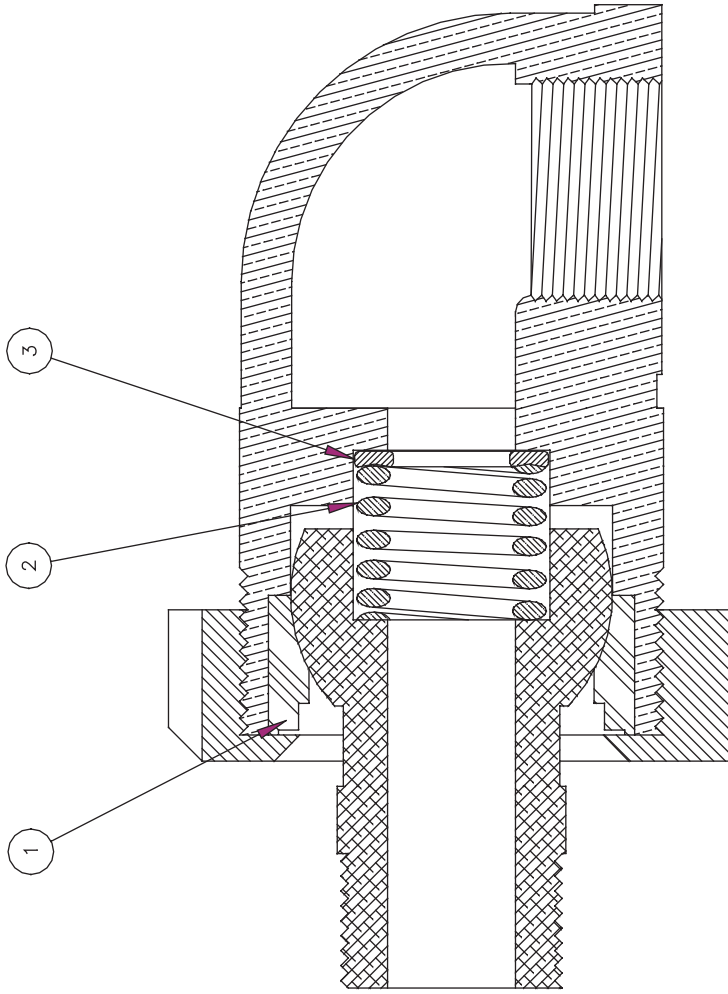

④ COMPLETE UNIT

	J.C.PARDO & SONS INC. 1250 REAMES RD. BALTO MD. 21220 PHONE (410) 391-3600	CHECKED BY: APPROVED BY:	DRAWN BY: JES DATE: 2/20/95 SCALE: NONE	SIZE: C REV: C	DRAWING NUMBER: 11079 SHEET: 1 of 1
REV.   DESCRIPTION   BY   DATE	1 1/4" NPT BARCO JOINT REPLACEMENT PARTS				
This drawing and all information contained therein are the property of J.C.Pardo & Sons, Inc. and must not be made public or copied, used, printed, or otherwise disseminated without the written consent of J.C.Pardo & Sons, Inc. This information is confidential and must not be made public or copied, used, printed, or otherwise disseminated in any way detrimental to J.C.Pardo & Sons, Inc.					
REVISIONS					



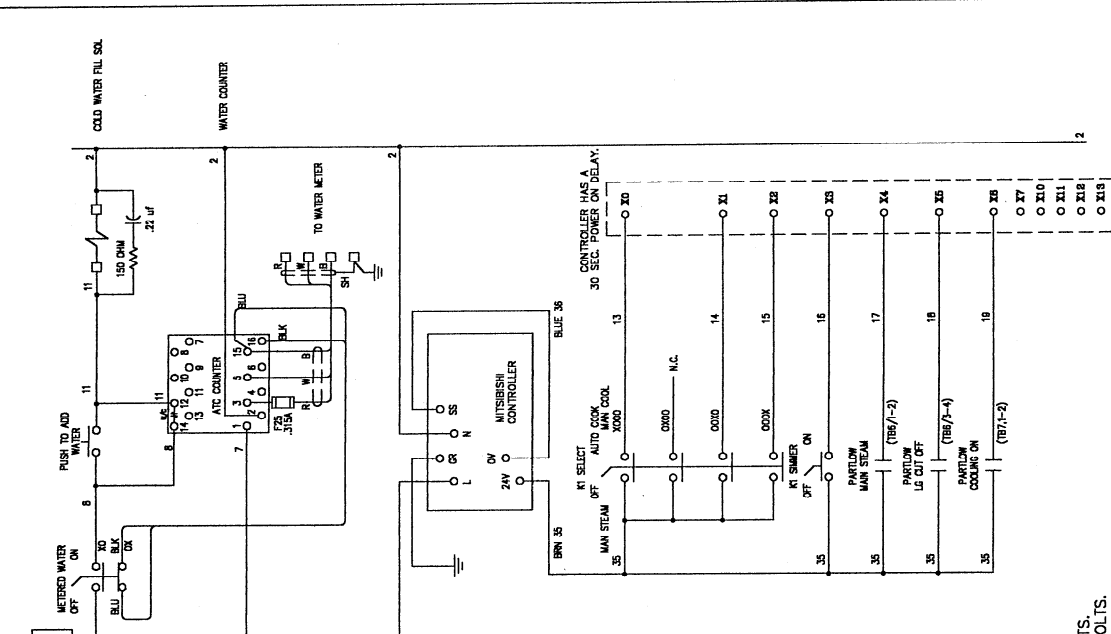
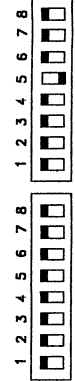

FLUSE NOTES:  
 F1-F6 FUSES KTK-R RATED 600 VOLTS.  
 F7 & F8 FUSES FNC-R RATED 600 VOLTS.  
 F9-F24 FUSES FNM RATED 250 VOLTS.  
 F25 & F26 FUSES GMA RATED 250 VOLTS.

REV.	DESCRIPTION	BY	DATE
	REVISIONS		
<b>J.C.PARDO &amp; SONS INC.</b> 1250 FRAMES RD. BALTO MD. 21220 PHONE (410) 391-3600 FAX (410) 391-8642			
DESIGNED BY	APPROVED BY	DATE	SCALE
DRUM	JAY S.	7/12/2000	NONE
DRUM NUMBER	REV.	ELECTRICAL SCHEMATIC 208V-3PH-60HZ DUAL C/P K-2 W/DUAL SENSORS	
ES-0204	C	BY INTERLOCK CONTROLS DIVISION OF J.C. PARDO & SONS INC. 1250 FRAMES RD. BALTO MD. 21220. THIS DRAWING IS THE PROPERTY OF J.C. PARDO & SONS INC. IT IS TO BE USED ONLY FOR THE PROJECT AND AT THE SITE SPECIFICALLY INDICATED THEREON.	
2 of 5			





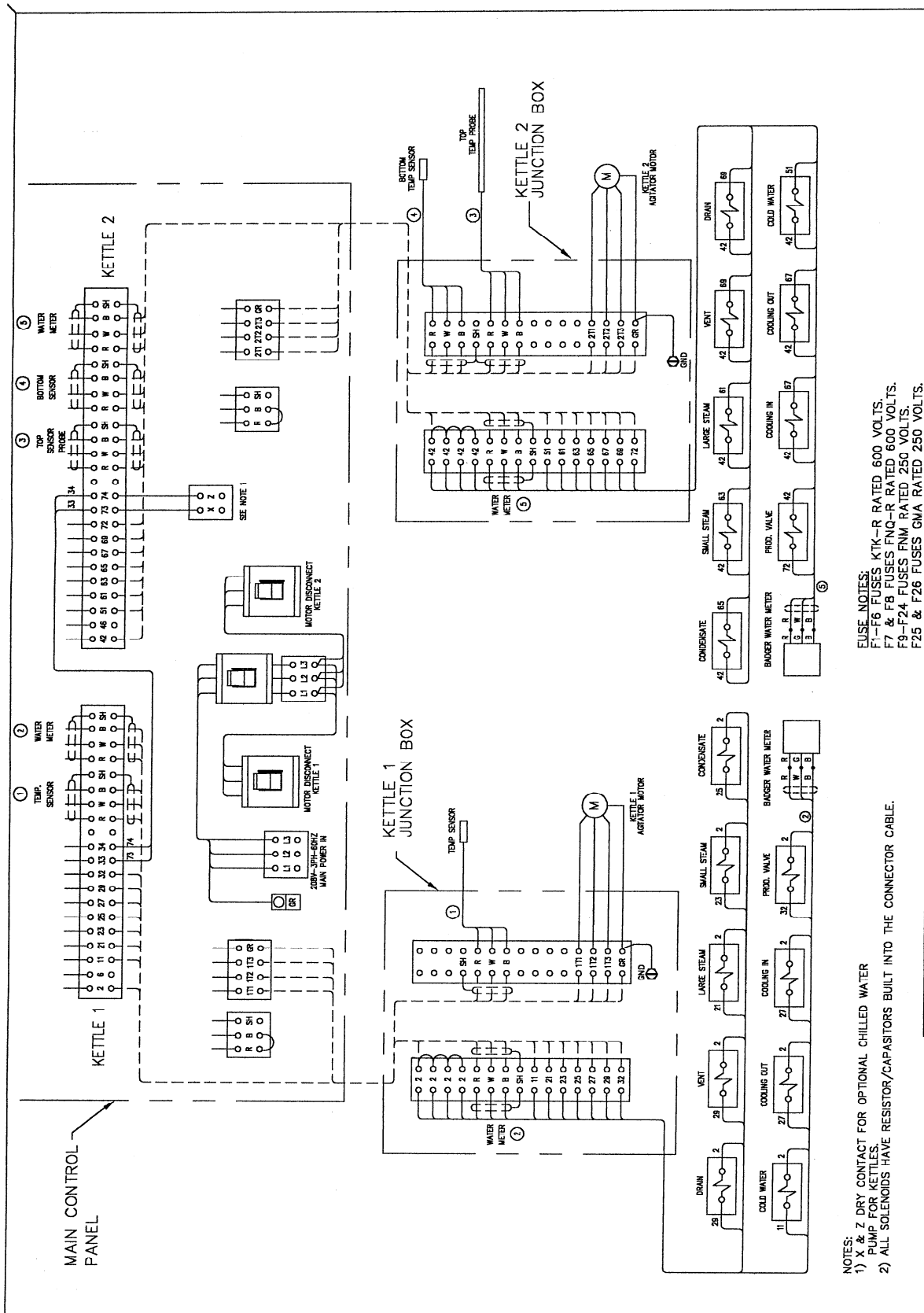

NOTES:  
 1) X & Z DRY CONTACT FOR OPTIONAL CHILLED WATER PUMP FOR KETTLES.  
 2) ALL SOLENOIDS HAVE RESISTOR/CAPACITORS BUILT INTO THE CONNECTOR CABLE.

FUSE NOTES:  
 F1-F6 FUSES KTK-R RATED 600 VOLTS.  
 F7 & F8 FUSES FNC-R RATED 600 VOLTS.  
 F9-F24 FUSES FMC-RATED 250 VOLTS.  
 F25 & F26 FUSES GMA RATED 250 VOLTS.

ELECTRICAL SCHEMATIC 208V-3PH-60HZ  
 DUAL SENSOR KETTLES  
 DATE 7/12/2000  
 DRAWN BY: JAY S.  
 APPROVED BY:

REV.	DESCRIPTION	BY	DATE
	REVISIONS		

**J.C.PARDO & SONS INC.**  
 1250 REAMES RD.  
 BALTO MD. 21220  
 PHONE (410) 381-9800  
 FAX (410) 381-9048

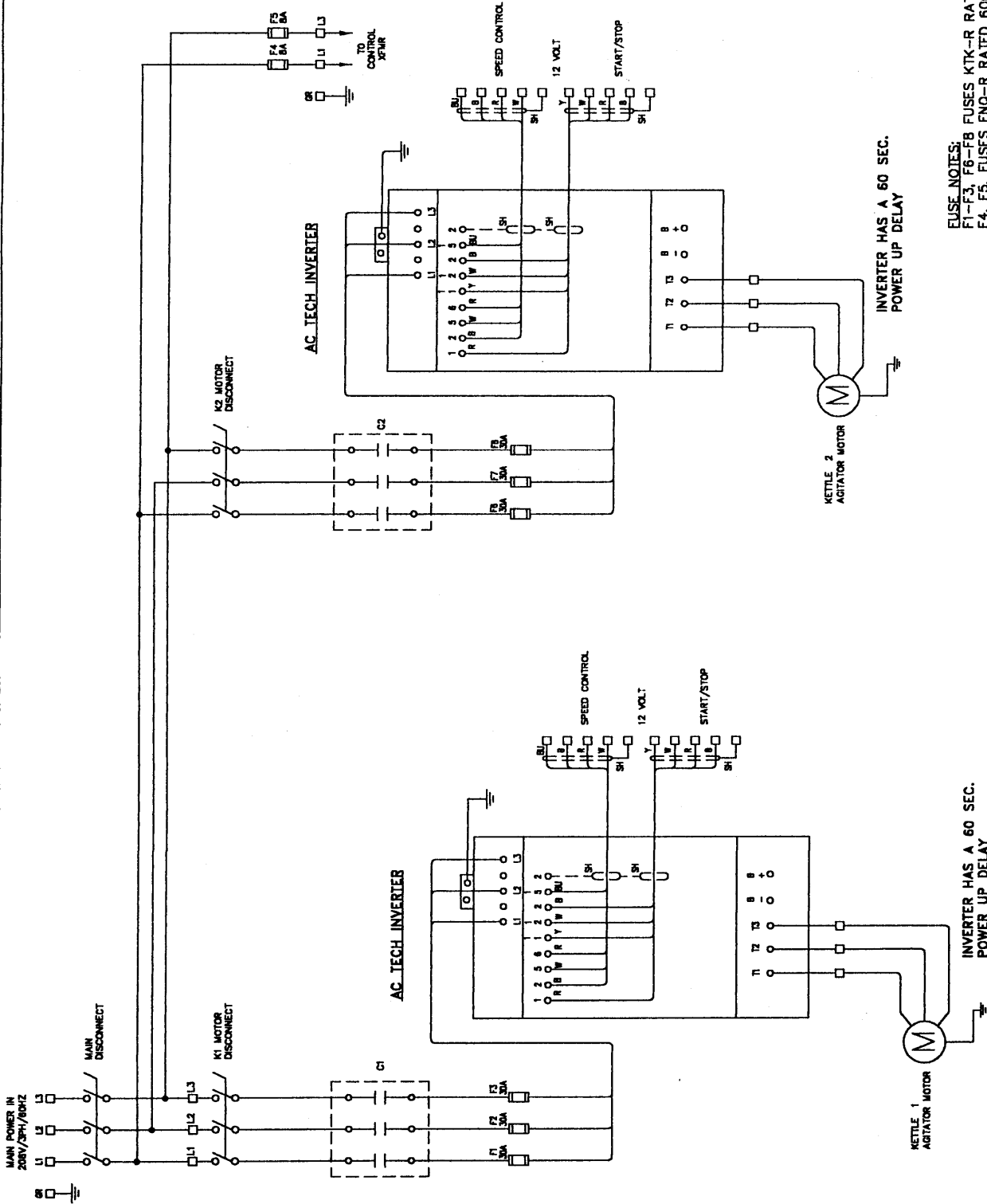

FUSE NOTES:  
 F1-F3, F6-F8 FUSES KTK-R RATED 600 VOLTS.  
 F4, F5, FUSES FNG-R RATED 600 VOLTS.  
 F9-F24 FUSES FNM RATED 250 VOLTS.  
 F25 & F26 FUSES GMA RATED 250 VOLTS.

<b>J.C.PARDO &amp; SONS INC.</b> 1260 REAMES RD. PICOCA (410) 361-3600		DESIGNED BY APPROVED BY	DRAWN BY J.S DATE 1/28/02 SCALE NONE	ELECTRICAL SCHEMATIC 208V 5HP DUAL CONTROL PANEL HOT/COLD <small>THIS DRAWING IS THE PROPERTY OF J.C.PARDO &amp; SONS INC. AND IS NOT TO BE REPRODUCED OR COPIED IN ANY MANNER WITHOUT THE WRITTEN PERMISSION OF J.C.PARDO &amp; SONS INC.</small>	DRAWING NUMBER <b>ES-0301</b>
REV. A DESCRIPTION 460V/5HP WAS 15 AMP	JES BY DATE	6/01	C	REV.	1 of 5
<b>REVISIONS</b>					

REDJON WATER COUNTER DIPP SWITCH SETTINGS



DIPP SWITCH #7 DOWN TO PROGRAM COUNTER & UP TO LOCKOUT COUNTER.

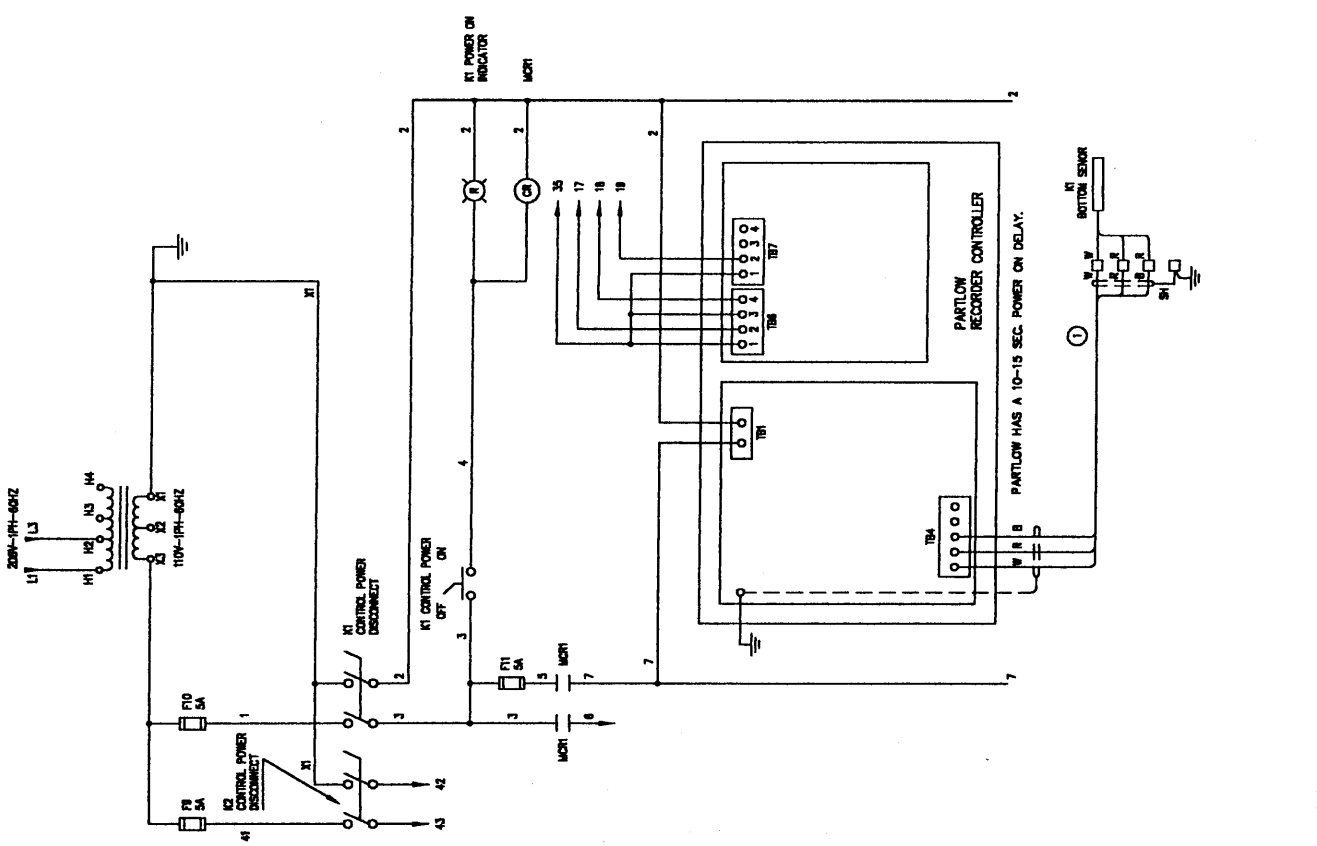
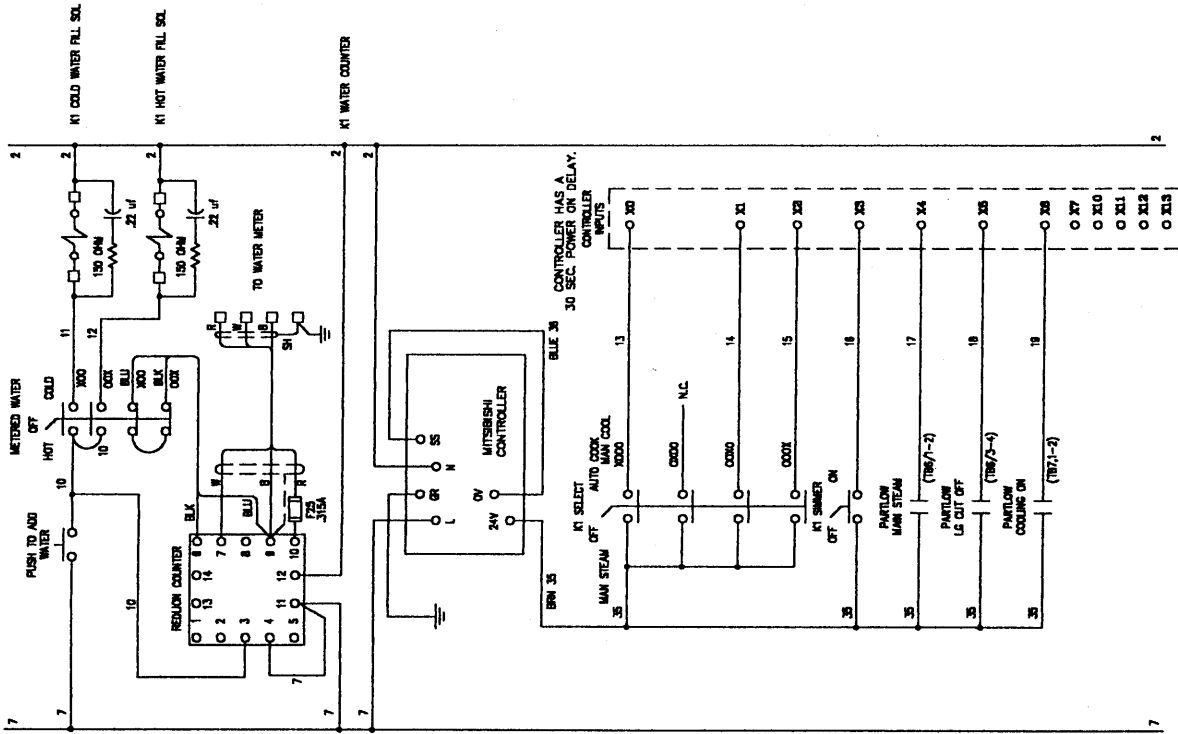

REV.	DESCRIPTION	BY	DATE
	REVISIONS		

ORDER BY	DATE
APPROVED BY	DATE
REVISIONS	DATE

**J.C.PARDO & SONS INC.**  
 1250 REAMIES RD. BALTO MD. 21220  
 PHONE (410) 381-9600 FAX (410) 381-9043

**ELECTRICAL SCHEMATIC 208V, 5HP DUAL CONTROL PANEL HOT/COLD**

ORDER NUMBER: ES-0301  
 SHEET: 2 of 5

CONTROLLER HAS A 30 SEC. POWER ON DELAY.

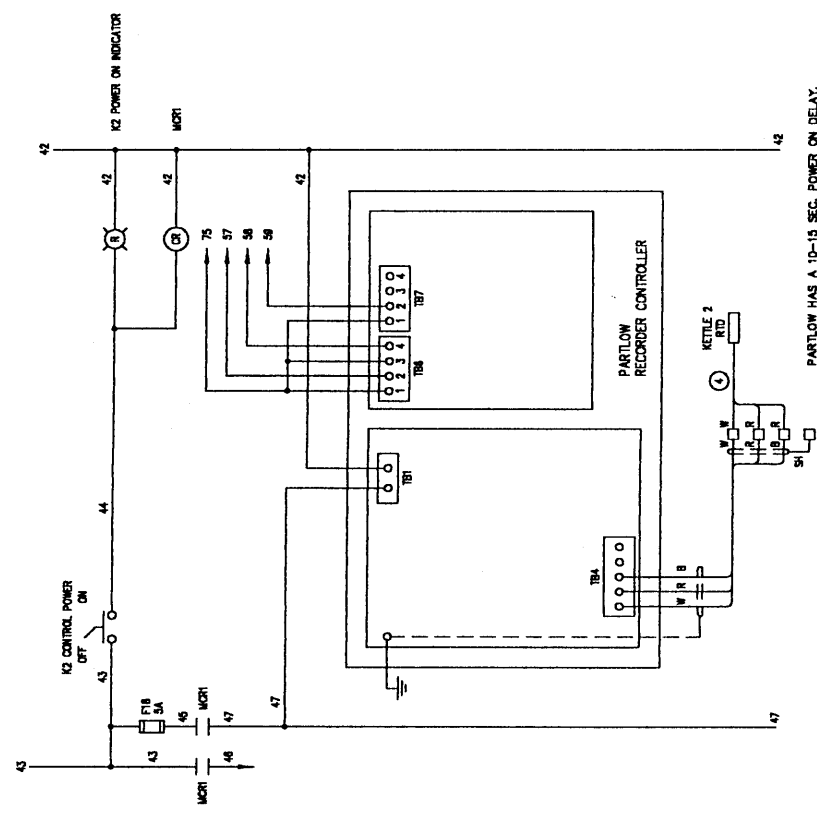
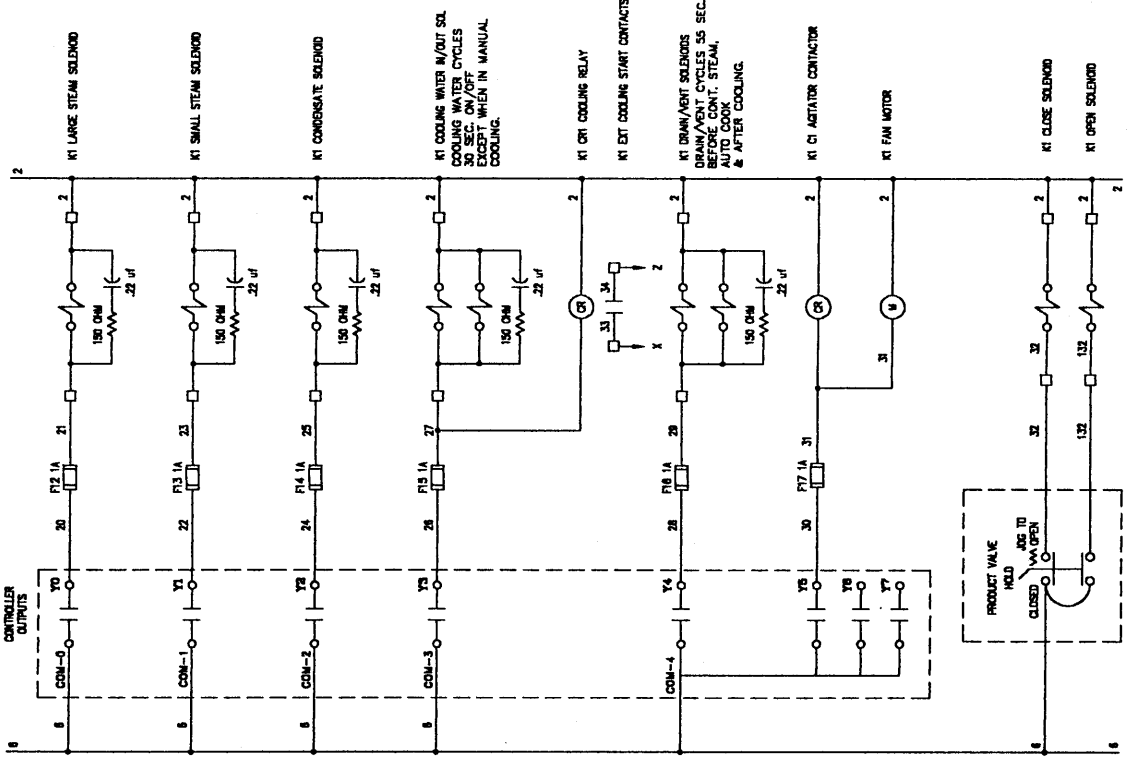

PARTLOW HAS A 10-15 SEC. POWER ON DELAY.

REV.	DESCRIPTION	BY	DATE	CHECKED BY		DATE	REV	REVISION NUMBER
				APPROVED BY		DATE	REV	REVISION NUMBER
	REVISIONS					1/28/02	C	ES-0301
								3 of 5

**J.C. PARDO & SONS INC.**  
 1250 REAMES RD. BALTO MD. 21220  
 PHONE (410) 981-8600 FAX (410) 981-8048

**ELECTRICAL SCHEMATIC 208V, 5HP DUAL CONTROL PANEL HOT/COLD**  
 This drawing is an information only drawing. It is not intended to be used as a basis for construction. It is intended to be used as a reference only. It is not intended to be used as a basis for construction. It is not intended to be used as a basis for construction.

REDLION WATER COUNTER DIPP SWITCH SETTINGS



DIPP SWITCH #7 DOWN TO PROGRAM COUNTER & UP TO LOCKOUT COUNTER.

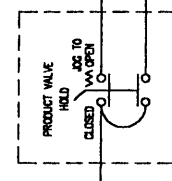
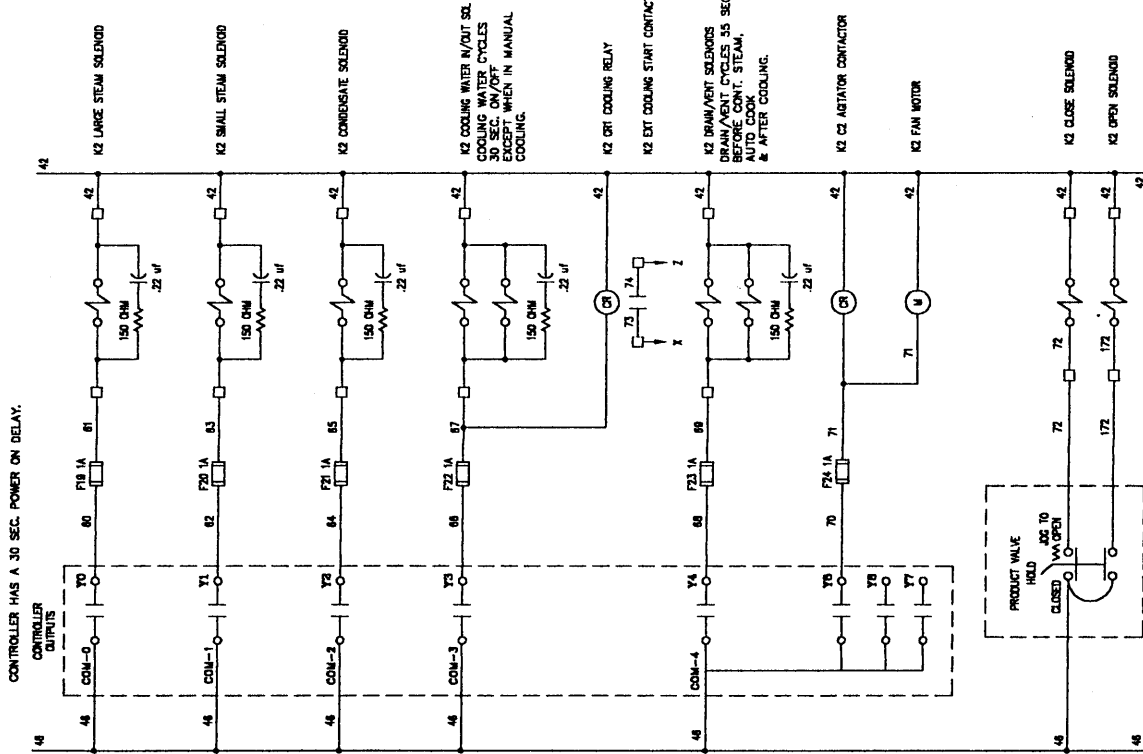
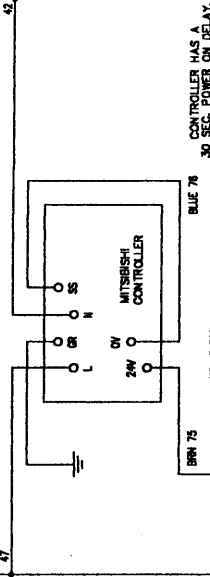
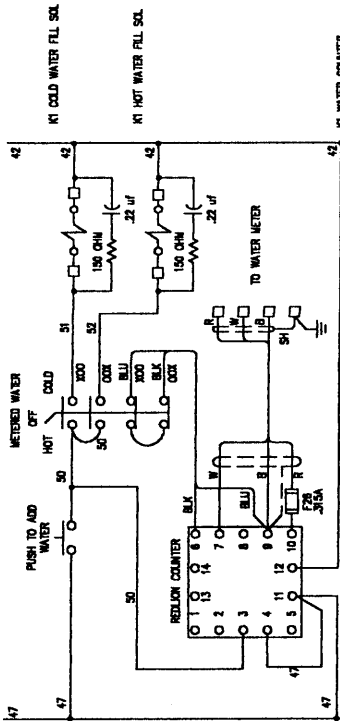

**J.C. PARDO & SONS INC.**  
 1260 REAMES RD. BALTO MD. 21220  
 PHONE (410) 381-3600 FAX (410) 381-9042

ELECTRICAL SCHEMATIC 208V, 5HP DUAL CONTROL PANEL HOT/COLD

DESIGNED BY: JS  
 DATE: 1/28/02  
 APPROVED BY: NONE

REVISION NUMBER: C  
 SHEET: 4 of 5

REV.	DESCRIPTION	BY	DATE
REVISIONS			

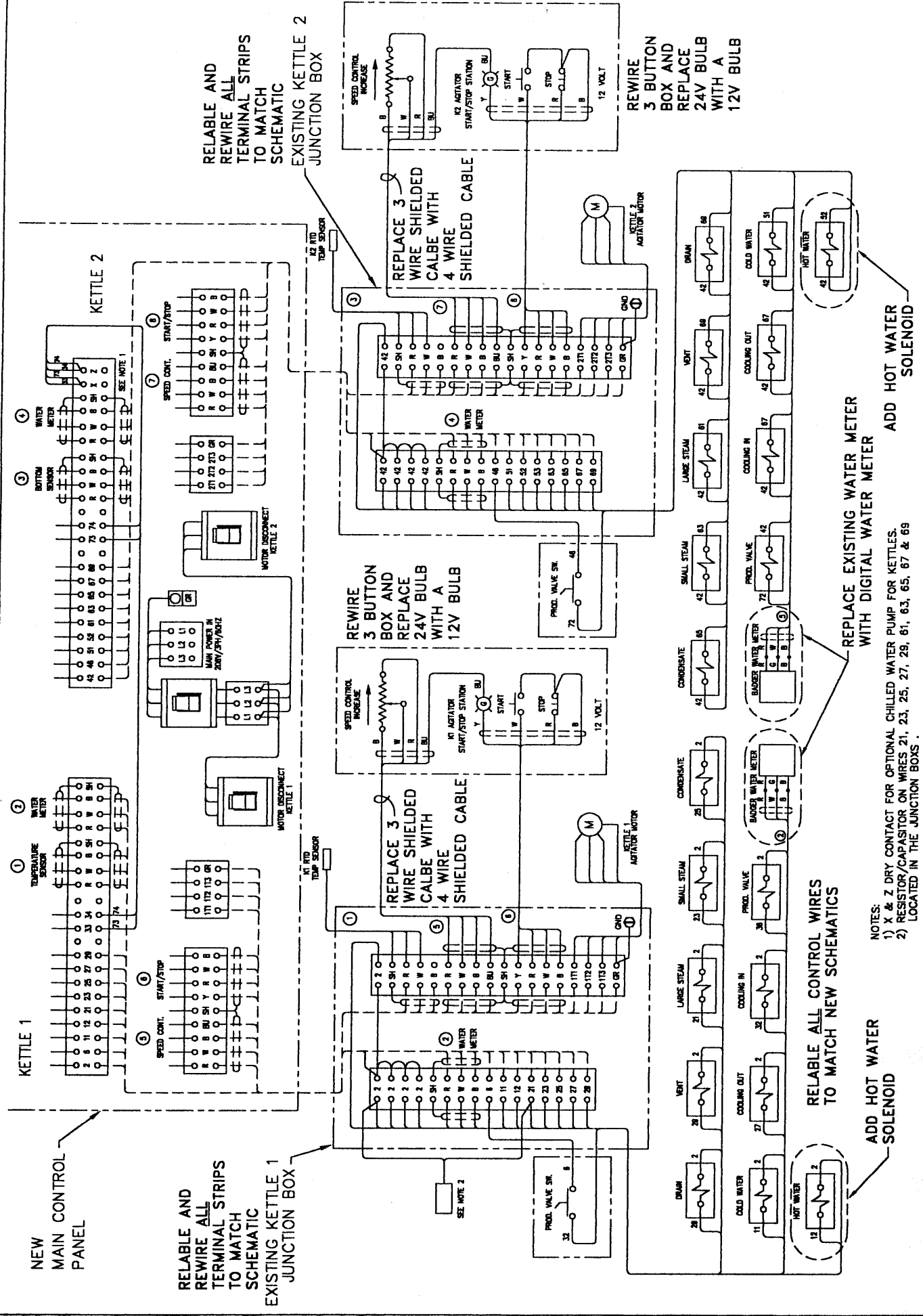

NEW MAIN CONTROL PANEL

RELIABLE AND REWIRE ALL TERMINAL STRIPS TO MATCH SCHEMATIC EXISTING KETTLE 1 JUNCTION BOX

RELIABLE AND REWIRE ALL TERMINAL STRIPS TO MATCH SCHEMATIC EXISTING KETTLE 2 JUNCTION BOX

REWIRE 3 BUTTON BOX AND REPLACE 24V BULB WITH A 12V BULB

REPLACE 3 WIRE SHIELDED CALBE WITH 4 WIRE SHIELDED CABLE

REWIRE 3 BUTTON BOX AND REPLACE 24V BULB WITH A 12V BULB

REPLACE EXISTING WATER METER WITH DIGITAL WATER METER

ADD HOT WATER SOLENOID

ADD HOT WATER SOLENOID

REPLACE EXISTING WATER METER WITH DIGITAL WATER METER

NOTES:  
 1) X & Z DRY CONTACT FOR OPTIONAL CHILLED WATER PUMP FOR KETTLES.  
 2) RESISTOR/CAPASITOR ON WIRES 21, 23, 25, 27, 29, 61, 63, 65, 67 & 69 LOCATED IN THE JUNCTION BOX.

REV.	DESCRIPTION	BY	DATE	REVISIONS
<b>J.C.PARDO &amp; SONS INC.</b> 1260 REAMERS RD. BALTO MD. 21220 PHONE (410) 391-9600 FAX (410) 391-9048				ORDERED BY DRAWN BY J.S. DATE 1/28/02 MADE NONE
ELECTRICAL SCHEMATIC 208V, 5HP DUAL CONTROL PANEL HOT/COLD				NUMBER DRAWING <b>C ES-0301</b> SHEET <b>5 of 5</b>

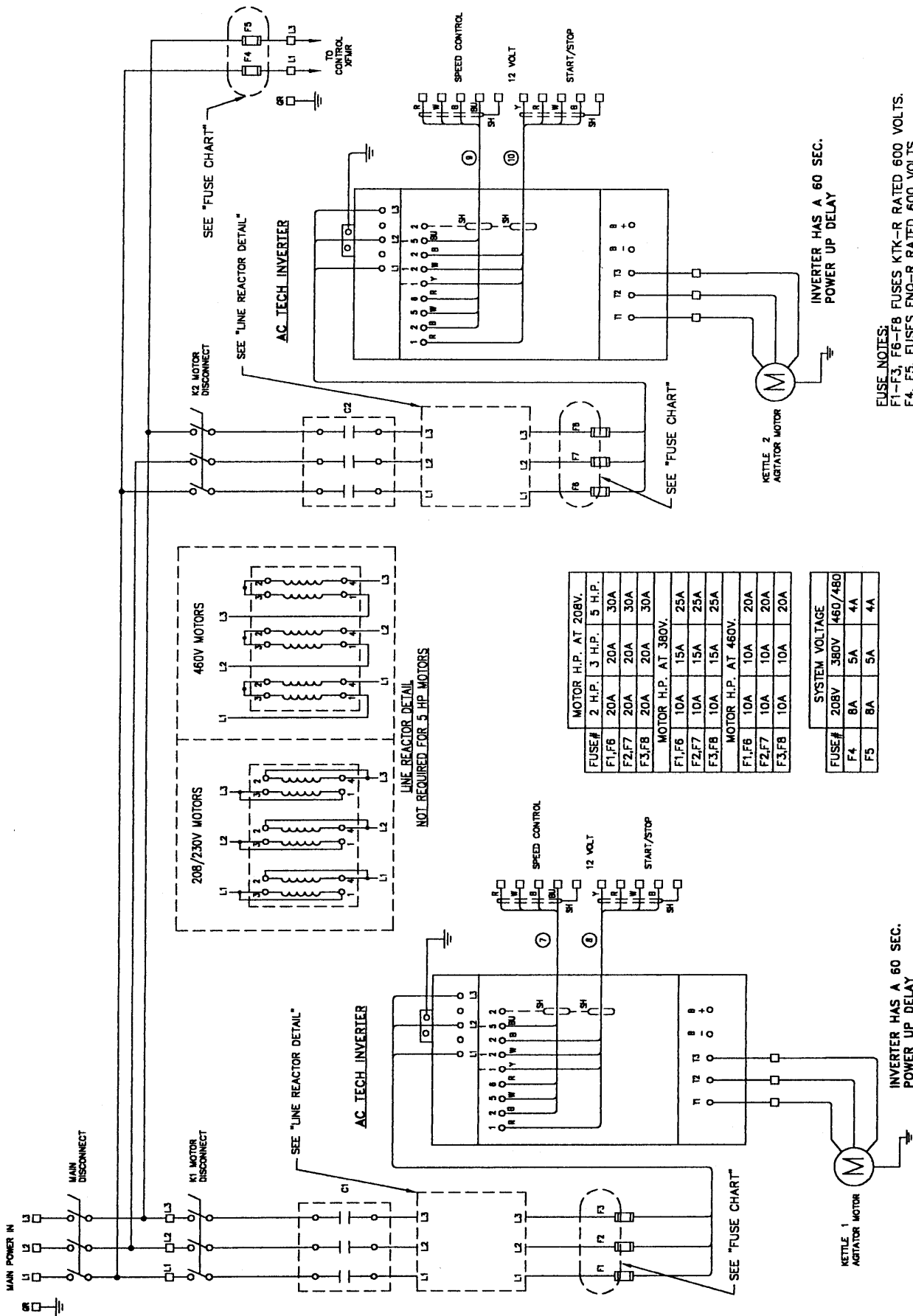

**FUSE NOTES:**  
 F1-F3, F6-F8 FUSES KTK-R RATED 600 VOLTS.  
 F4, F5, FUSES FNO-R RATED 600 VOLTS.  
 F9-F24 FUSES FNM RATED 250 VOLTS.  
 F25 & F26 FUSES GMA RATED 250 VOLTS.

INVERTER HAS A 60 SEC.  
 POWER UP DELAY

INVERTER HAS A 60 SEC.  
 POWER UP DELAY

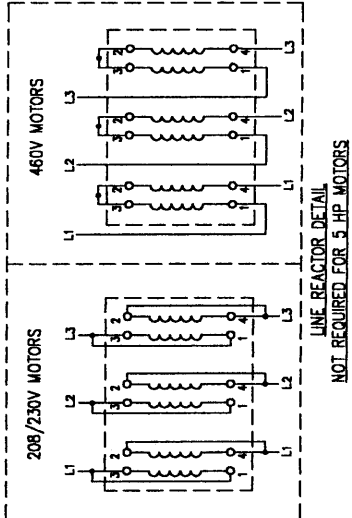

FUSE#	2 H.P.	3 H.P.	5 H.P.
F1,F6	20A	20A	30A
F2,F7	20A	20A	30A
F3,F8	20A	20A	30A

MOTOR H.P. AT 208V.	10A	15A	25A
F1,F6	10A	15A	25A
F2,F7	10A	15A	25A
F3,F8	10A	15A	25A

MOTOR H.P. AT 460V.	10A	10A	20A
F1,F6	10A	10A	20A
F2,F7	10A	10A	20A
F3,F8	10A	10A	20A

FUSE#	208V	380V	460/480
F4	8A	5A	4A
F5	8A	5A	4A

**FUSE CHARTS**

REV. A	460V/SHP WAS 15 AMP	JES	6/01
	DESCRIPTION	BY	DATE
<b>REVISIONS</b>			
<b>J.C. PARDO &amp; SONS INC.</b> 1250 REAMES RD. FREDERIE (410) 391-8600		BALTO MD. 21220 FAX (410) 391-9043	
DESIGNED BY	DRAWN BY JS	DATE	1/28/02
APPROVED BY	SCALE	NONE	
<b>ELECTRICAL SCHEMATIC 208/230/380/460V          DUAL CONTROL PANEL K-1 W/DUAL SENSORS</b>		SHEET <b>ES-0300</b>	DRAWING NUMBER <b>1 of 5</b>





REDON WATER COUNTER DIPP SWITCH SETTINGS



DIPP SWITCH #7 DOWN TO PROGRAM COUNTER & UP TO LOCKOUT COUNTER.

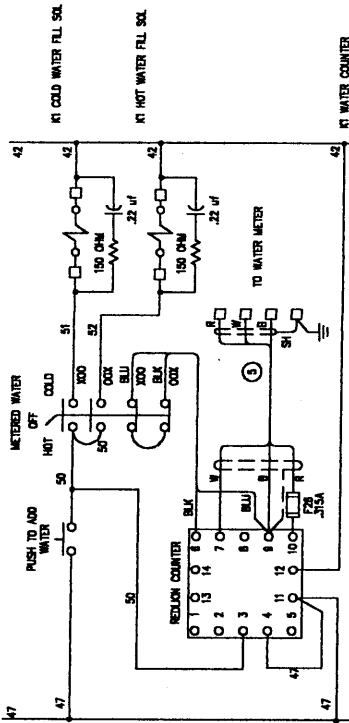

K1 HOT WATER FILL SOL

K1 WATER COUNTER

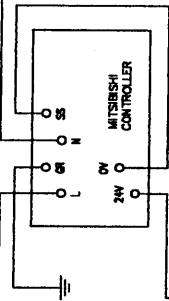

CONTROLLER HAS A 30 SEC. POWER ON DELAY.

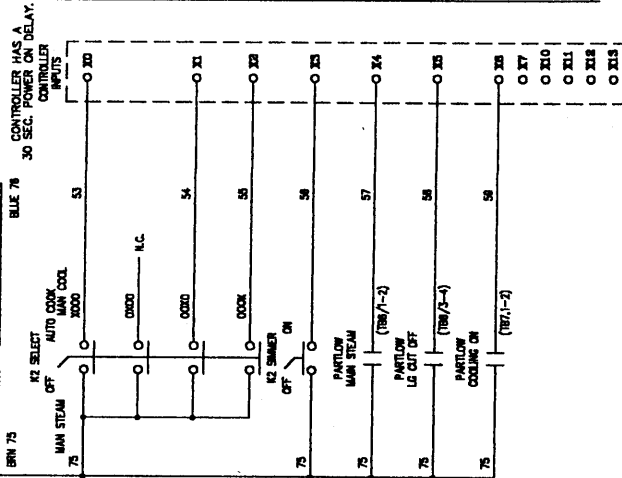

CONTROLLER HAS A 30 SEC. POWER ON DELAY.

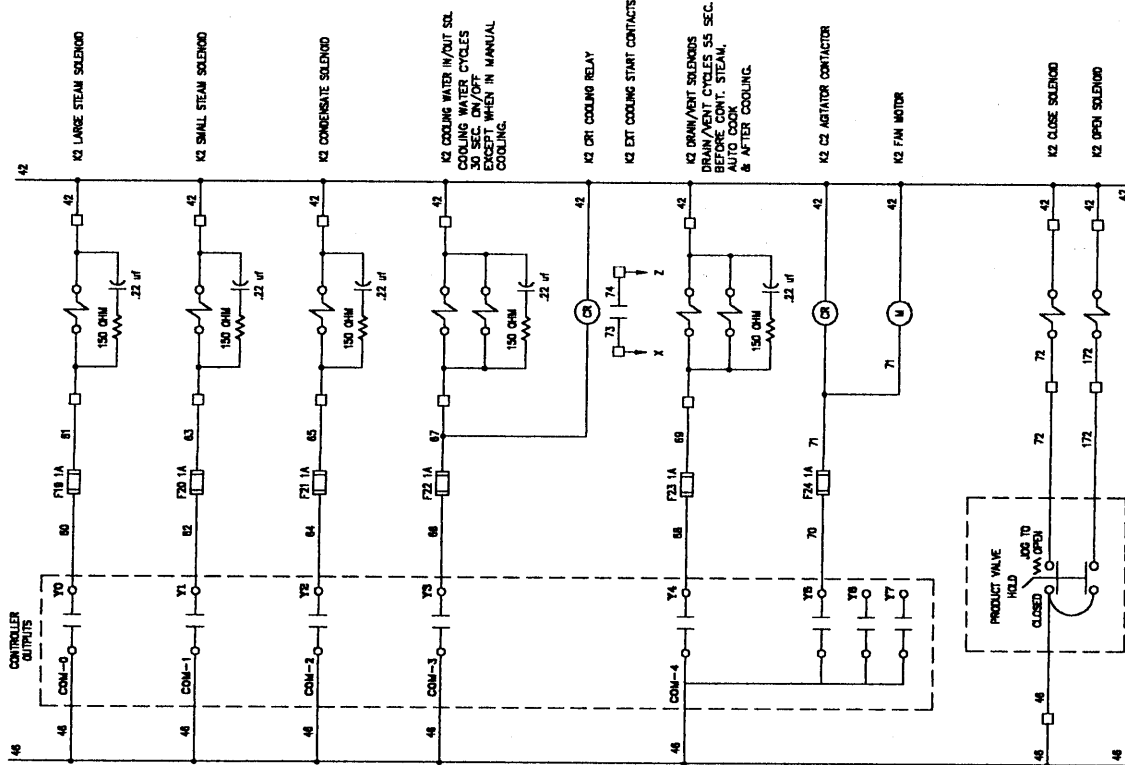

**J.C. PARDO & SONS INC.**  
 1250 REAMES RD. BALTO MD. 21220  
 PHONE (410) 361-9600 FAX (410) 361-8048

REV.	DESCRIPTION	BY	DATE
	REVISIONS		

DESIGNED BY	DATE
JS	1/28/02

ORDER NO.	DATE	QUANTITY	UNIT
208/230/380/460V			
DUAL CONTROL PANEL K-1			
W/DUAL SENSORS			

REV.	DESCRIPTION	BY	DATE
4	of 5		

This document is the property of J.C. Pardo & Sons. It is to be used for the specific equipment and must not be made public or otherwise distributed without the written consent of J.C. Pardo & Sons.



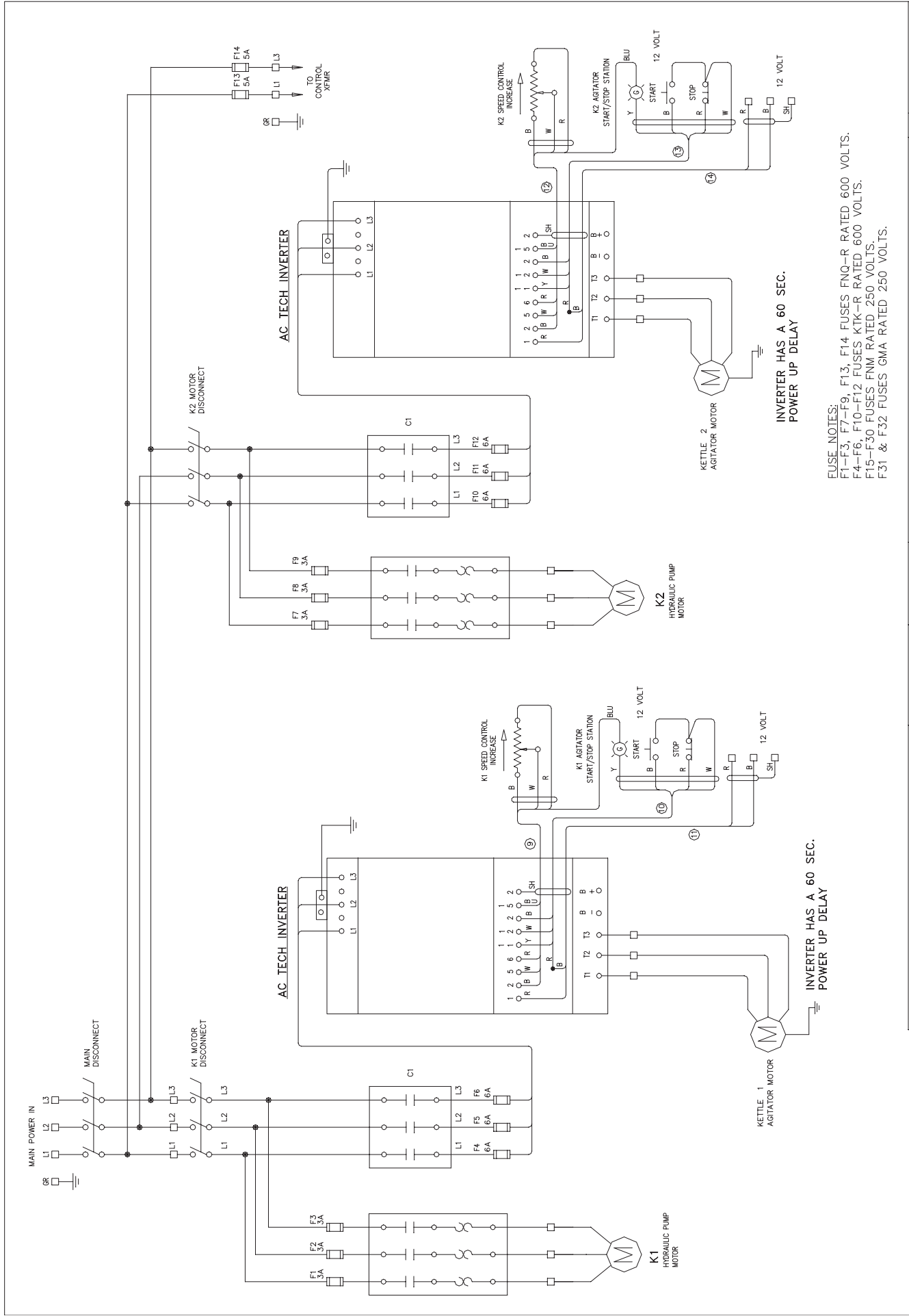

FUSE NOTES:  
 F1-F3, F7-F9, F13, F14 FUSES FNQ-R RATED 600 VOLTS.  
 F4-F6, F10-F12 FUSES KTK-R RATED 600 VOLTS.  
 F15-F30 FUSES FNM RATED 250 VOLTS.  
 F31 & F32 FUSES GMA RATED 250 VOLTS.

A		460V/5HP WAS 15 AMP	JES	6/01
REV.	DESCRIPTION		BY	DATE
REVISIONS				
<b>J.C.PARDO &amp; SONS INC.</b> 1250 REAMES RD. BALTO MD. 21220 PHONE (410) 391-9600 FAX (410) 391-9042				
CHECKED BY:		DRAWN BY: JES		
APPROVED BY:		DATE: 2/26/03		
		SCALE: NONE		
SIZE:		DRAWING NUMBER:		
C		ES-0323		
REV.		SHEET		
1		1 of 6		

REDLION WATER COUNTER DIPP SWITCH SETTINGS



DIPP SWITCH #7 DOWN TO PROGRAM COUNTER & UP TO LOCKOUT COUNTER.

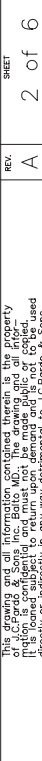
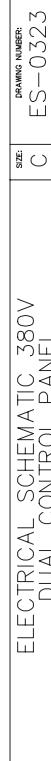
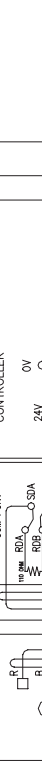
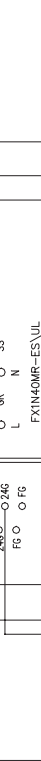
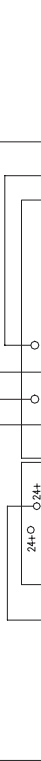
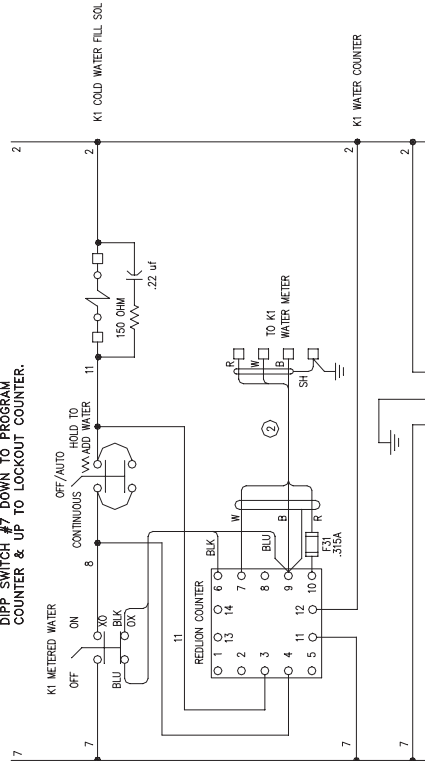

FUSE NOTES:  
 F1-F3, F7-F9, F13, F14 FUSES FNO-R RATED 600 VOLTS.  
 F4-F6, F10-F12 FUSES KTK-R RATED 600 VOLTS.  
 F15-F30 FUSES FNM RATED 250 VOLTS.  
 F31 & F32 FUSES GMA RATED 250 VOLTS.

REV. A	ADD K1 PARTLOW LINK	JES	7/03
	DESCRIPTION	BY	DATE
REVISIONS			

CHECKED BY:	DATE: 2/26/03
APPROVED BY:	SCALE: NONE

**J.C. PARDO & SONS INC.**  
 1250 REAMES RD. BALTO MD. 21220  
 PHONE (410) 391-9600 FAX (410) 391-9042

DRAWN BY: JES	DATE: 2/26/03
SCALE: NONE	

ELECTRICAL SCHEMATIC 380V DUAL CONTROL PANEL

SIZE: C	DRAWING NUMBER: ES-0323
REV. A	SHEET 2 of 6

CONTROLLER HAS A 30 SEC. POWER ON DELAY.

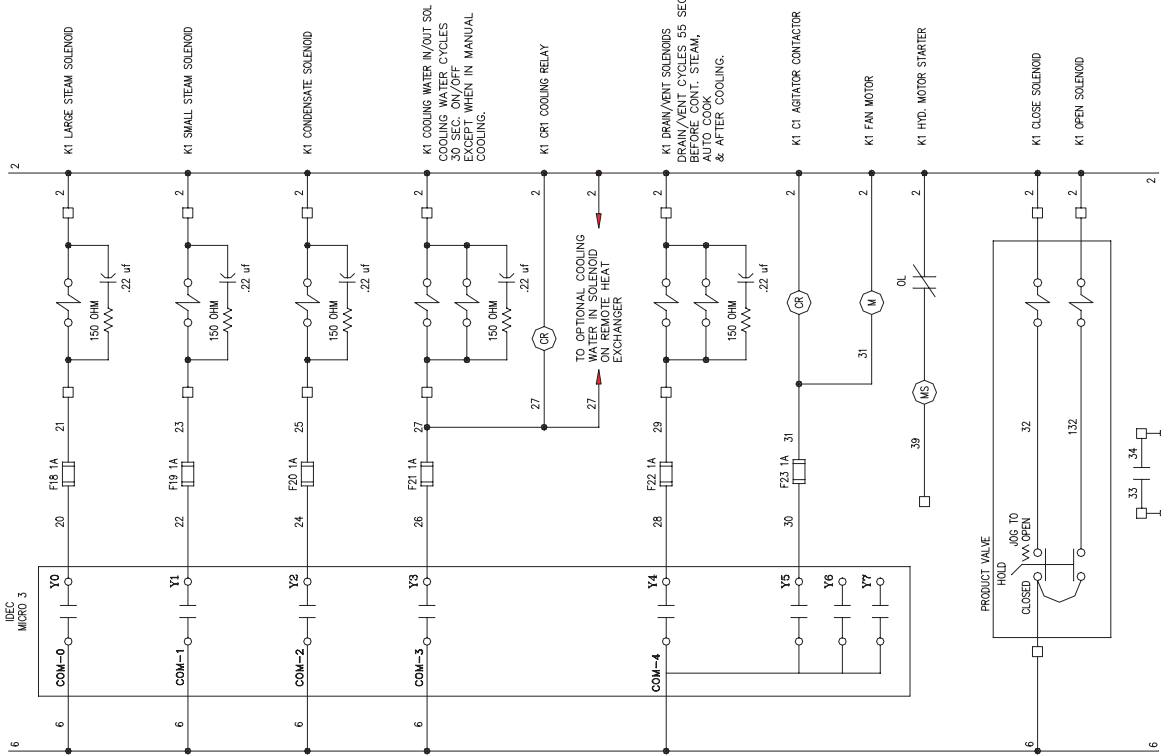

K1 EXT COOLING START CONTACTS

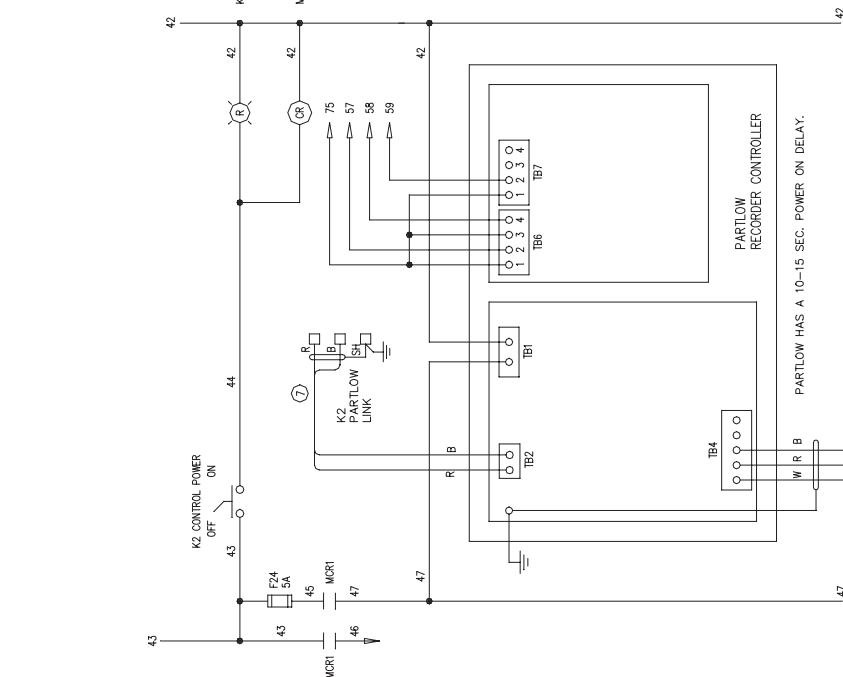

PARTLOW HAS A 10-15 SEC. POWER ON DELAY.

FUSE NOTES:  
 F1-F3, F7-F9, F13, F14: FUSES FNO-R RATED 600 VOLTS.  
 F4-F6, F10-F12 FUSES KTK-R RATED 600 VOLTS.  
 F15-F30 FUSES FNM RATED 250 VOLTS.  
 F31 & F32 FUSES GMA RATED 250 VOLTS.

REV. A		ADD K2 PARTLOW LINK		JES	7/03	DRAWN BY: JBS		DATE: 2/26/03	SCALE: NONE	SEE: C	DRAWING NUMBER: ES-0323
DESCRIPTION		BY		DATE		APPROVED BY:				REV. A	SHEET 3 of 6
REVISIONS											

**J.C. PARDO & SONS INC.**  
 1250 REAMES RD.  
 BALTO MD. 21220  
 PHONE (410) 391-3600  
 FAX (410) 391-9042

**ELECTRICAL SCHEMATIC 380V DUAL CONTROL PANEL**  
 This drawing and all information contained therein is the property of J.C. Pardo & Sons Inc. Balto Md. The drawing and all information contained herein is not to be used for any other project without the written consent of J.C. Pardo & Sons. It is to be returned to the originator upon demand and is not to be used directly or indirectly in any way detrimental to J.C. Pardo & Sons.

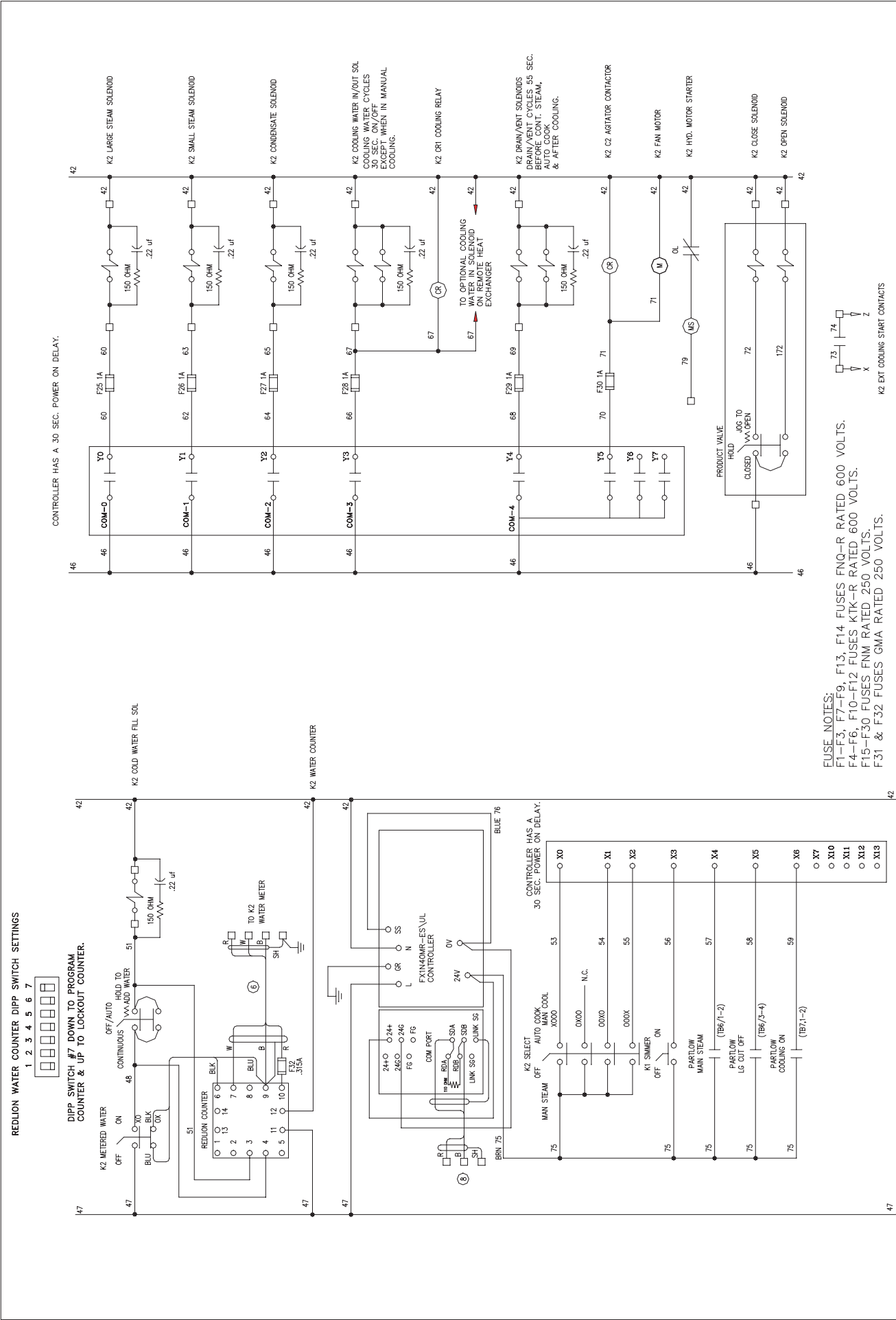

CONTROLLER HAS A 30 SEC. POWER ON DELAY.

CONTROLLER HAS A 30 SEC. POWER ON DELAY.

**FUSE NOTES:**  
 F1-F3, F7-F9, F13, F14 FUSES FNQ-R RATED 600 VOLTS.  
 F4-F6, F10-F12 FUSES KTK-R RATED 600 VOLTS.  
 F15-F30 FUSES FNM RATED 250 VOLTS.  
 F31 & F32 FUSES GMA RATED 250 VOLTS.

K2 EXT COOLING START CONTACTS

<b>J.C. PARDO &amp; SONS INC.</b> 1250 REAMES RD. BALTO MD. 21220 PHONE (410) 391-9600		CHECKED BY: DRAWN BY: JES DATE: 2/26/03 SCALE: NONE	DRAWING NUMBER: <b>ES-0323</b>
DESCRIPTION: <b>ELECTRICAL SCHEMATIC 380V DUAL CONTROL PANEL</b>		SIZE: C	SHEET: 4 of 6
REVISIONS:		REV.	SHEET

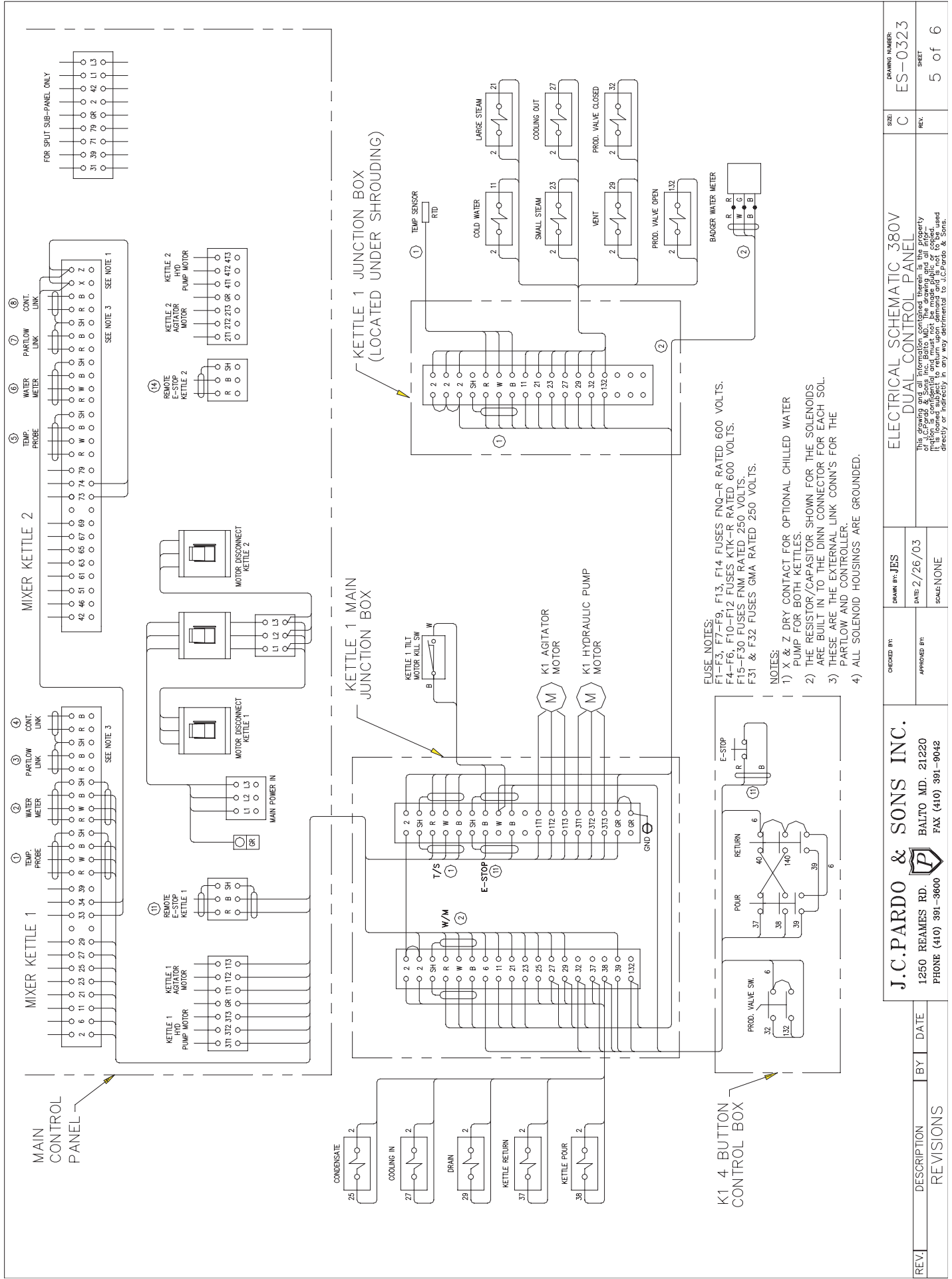

REV.	DESCRIPTION	BY	DATE	REVISIONS
				5 of 6
<b>J.C. PARDO &amp; SONS INC.</b> 1250 REAMES RD. BALTO MD. 21220 PHONE (410) 391-9600 FAX (410) 391-9042				DRAWN BY: JES DATE: 2/26/03 APPROVED BY: [Signature] SOMEONE
ELECTRICAL SCHEMATIC 380V DUAL CONTROL PANEL				DRAWING NUMBER: ES-0323 SIZE: C REV. 5 of 6

This drawing and all information contained therein is the property of J.C. Pardo & Sons Inc. Being not be made, copied or altered in any way without the written consent of J.C. Pardo & Sons. It is loaned subject to return upon demand and is not to be used directly or indirectly in any way detrimental to J.C. Pardo & Sons.

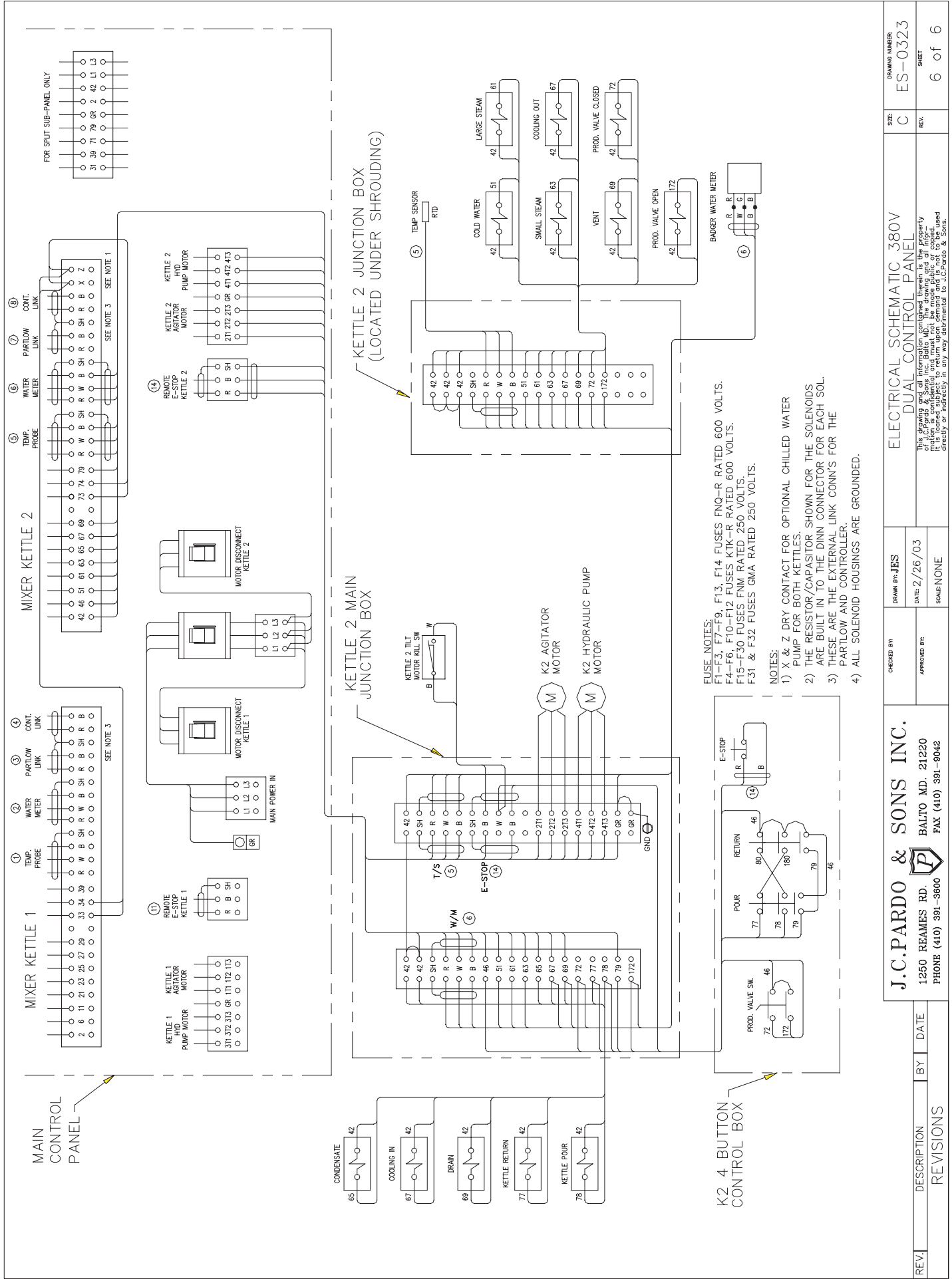

REV.	DESCRIPTION	BY	DATE	REVISIONS
<b>J.C. PARDO &amp; SONS INC.</b> 1250 REAMES RD. BALTO MD. 21220 PHONE (410) 391-9600 FAX (410) 391-9042				CHECKED BY: JES DATE: 2/26/03 APPROVED BY: SOMEONE
<b>ELECTRICAL SCHEMATIC 380V DUAL CONTROL PANEL</b>				DRAWING NUMBER: ES-0323 SIZE: C SHEET: 6 of 6

## FUSE CHART

FUSE NO	TYPE	VOLT	AMP
F1	FNQ-R	600	3 AMP
F2	FNQ-R	600	3 AMP
F3	FNQ-R	600	3 AMP
F4	KTK-R	600	15 AMP
F5	KTK-R	600	15 AMP
F6	KTK-R	600	15 AMP
F7	FNQ-R	600	3 AMP
F8	FNQ-R	600	3 AMP
F9	FNQ-R	600	3 AMP
F10	KTK-R	600	15 AMP
F11	KTK-R	600	15 AMP
F12	KTK-R	600	15 AMP
F13	FNQ-R	600	5 AMP
F14	FNQ-R	600	5 AMP
F15	FNM	250	5 AMP
F16	FNM	250	5 AMP
F17	FNM	250	5 AMP
F18	FNM	250	1 AMP
F19	FNM	250	1 AMP
F20	FNM	250	1 AMP
F21	FNM	250	1 AMP
F22	FNM	250	1 AMP
F23	FNM	250	1 AMP
F24	FNM	250	5 AMP
F25	FNM	250	1 AMP
F26	FNM	250	1 AMP
F27	FNM	250	1 AMP
F28	FNM	250	1 AMP
F29	FNM	250	1 AMP
F30	FNM	250	1 AMP
F31	GMA	250	.315 AMP
F32	GMA	250	.315 AMP

FIELD WIRING MUST ENTER/EXIT BOTTOM  
OF ENCLOSURE OR THROUGH APPROVED FITTING.

### J.C. PARDO AND SONS INC.

C.R. MODEL NO.: HA-DE-CC-2

J.C.P. MODEL NO.: FMCC-D2-K

SERIAL NO.: 8226

LARGEST MOTOR RATING: 3 H.P.

RATED VOLTAGE: 380 V.A.C.

PHASE: 3 PH

CYCLES: 50 HZ

FULL LOAD CURRENT: 18 AMPS

MINIMUM CIR. AMPACITY: 19 AMPS

MAXIMUM OVERCURRENT DEVICE: 25 AMPS

380V 3HP

PROCEDURE TO TIGHTEN SPRING IN LID ACTUATOR

1. MAKE SURE KETTLE LID IS IN THE UP POSITION
2. HOLD TENSION ON THE ALLEN WRENCH REMOVE THE ALLEN SCREWS ITEM #4.
3. PULL DOWN ON ALLEN WRENCH UNTIL THE 2nd SET OF HOLES APPEAR IN LINE. REINSTALL ALLEN SCREWS NOTE THE ALLEN WRENCH SHOULD TRAVEL 1/4 TURN (90° TO 100°)

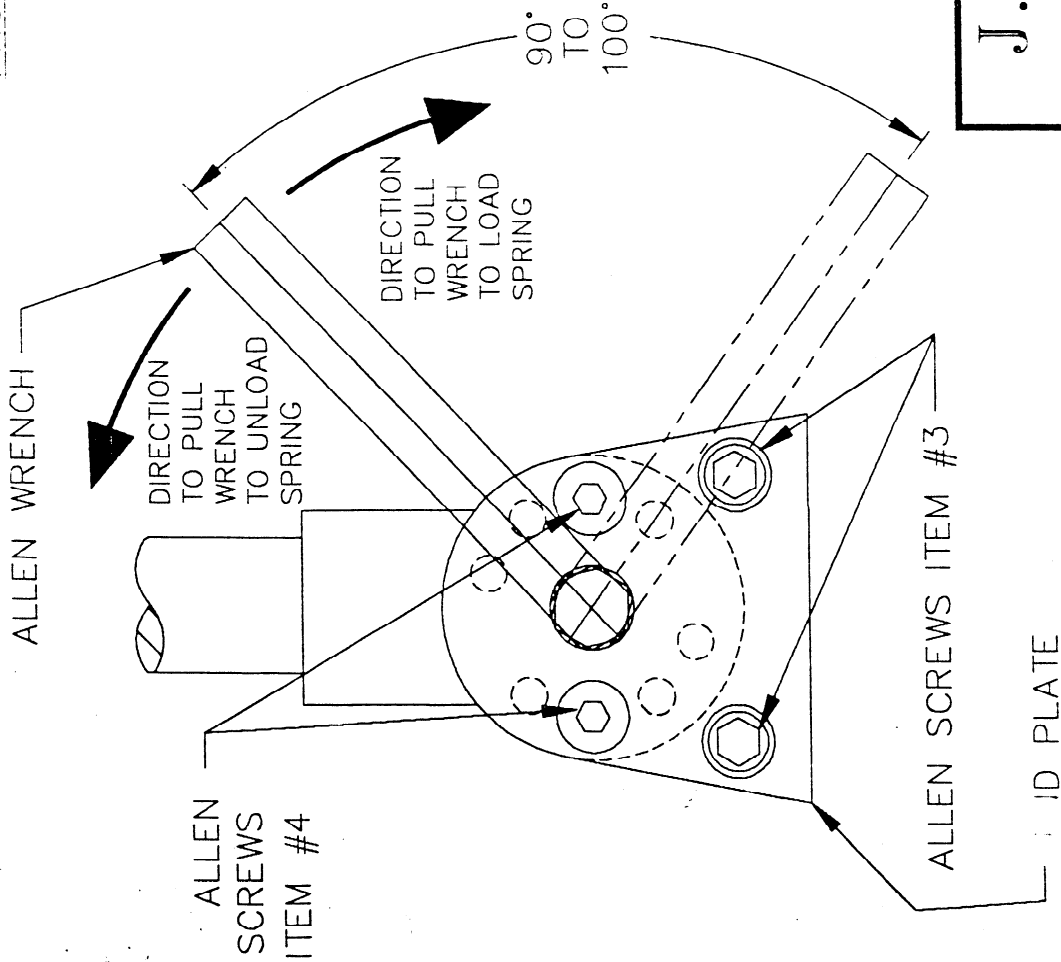

PROCEDURE FOR REPLACING SPRING IN LID ACTUATOR

- A. MAKE SURE THE KETTLE LID IS IN THE UP POSITION AND PROPERLY SUPPORTED BEFORE REMOVING ANY ALLEN SCREWS.
- B. USING THE ALLEN WRENCH HOLD TENSION ON THE SPRING WHEN REMOVING THE ALLEN SCREWS ITEM #4 USING THE ALLEN WRENCH UNLOAD THE SPRING.
- C. CAREFULLY REMOVE THE ALLEN SCREWS ITEM #3 AND REMOVE THE END PLATE.
- D. REMOVE THE OLD SPRING AND CENTERING ROD
- E. GREASE NEW SPRING AND CENTERING ROD BEFORE INSTALLING THEM INTO HOUSING. NOTE USE CHESTERTON 622, USDA APPROVED, OR EQUIVALENT GREASE.
- F. REPLACE THE END PLATE AND REPLACE THE ALLEN SCREWS ITEM #3.
- G. USING THE ALLEN WRENCH TIGHTEN THE SPRING AND ALIGN THE HOLES REPLACE THE ALLEN SCREWS ITEM #4.

**J. C. PARDO & SONS INC.**



1250 REAMES RD. BALTO. MD. 21220

SCALE: NONE	APPROVED BY:	DRAWN BY:
DATE: 5-16-94		TIM KAHL
ACTUATOR SPRING ADJUSTMENT AND REPLACEMENT DETAIL		
SMALL ACTUATOR UP TO 100 GALLON KETTLES	SIZE: A	DRAWING NUMBER: 8545
		REV: B

## INSTALLATION INSTRUCTIONS

1. INSERT PART "A" INTO KETTLE FERRULE PART "E" SO PART "A" IS FLUSH WITH INTERNAL KETTLE SURFACE  $\pm .032$  TO AVOID SCRAPER BLADE FROM INTERFERING WITH TEMPERATURE PROBE.
2. INSERT PART "B" ASSEMBLY INTO PART "A" AND ADJUST UNTIL SURFACE OF PART IS FLUSH WITH INTERNAL KETTLE SURFACE, SO THAT THE SCRAPER BLADE WILL WIPE THE SURFACE CLEAN. THIS MUST OCCUR TO OBTAIN AN ACCURATE TEMPERATURE READING FROM THE PROBE. FOR EASIER ADJUSTMENT OF PROBE, INSTALL O-RINGS AFTER ALL ADJUSTMENTS HAVE BEEN MADE.
3. AFTER STEPS 1 AND 2, INSTALL CLAMP "F" AND CHECK INTERNAL SURFACE WITH PROBE TO FIT THE ABOVE REQUIREMENTS. ADJUST, IF REQUIRED.
4. TIGHTEN BOTH SET SCREWS "D".
5. TIGHTEN CONNECTOR "C".
6. RUN WIRE TO JUNCTION BOX AND ATTACH TO BOX.
7. TEST TEMPERATURE PROBE TO SEE IF TEMPERATURE READING IS ACCURATE.

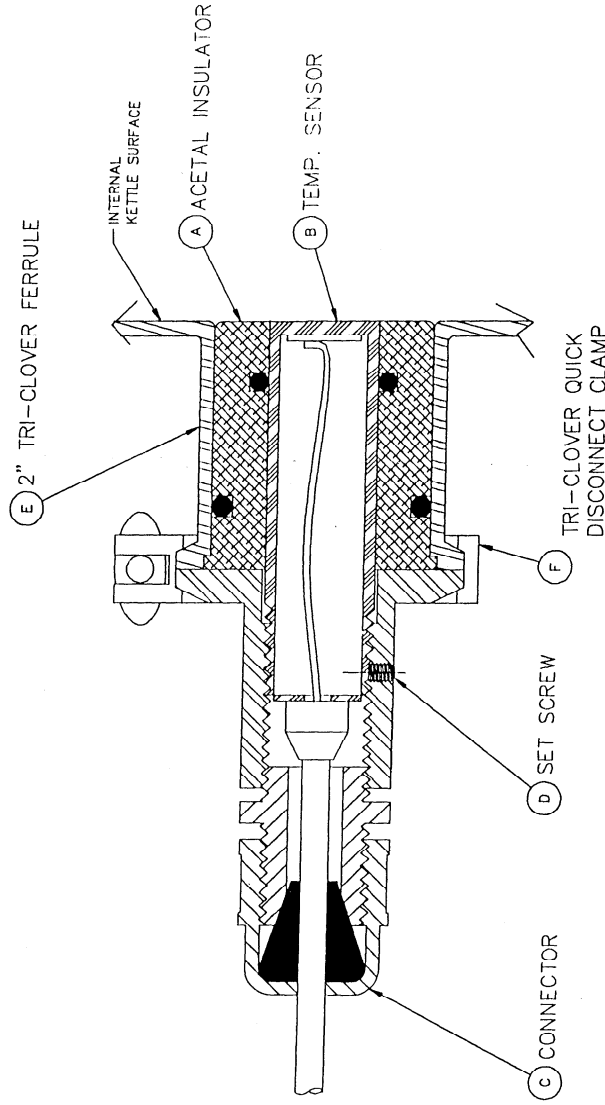

### NOTE:

USE CHESTERTON 622, USDA APPROVED OR EQUIVALENT ON O-RINGS BEFORE INSTALLATION.

JOB #

QTY:

THIS DRAWING AND ALL INFORMATION CONTAINED THEREIN IS THE PROPERTY OF J. C. PARDO & SONS, INC. BALTO. MD. 21220	
THE DRAWING AND INFORMATION AND MUST NOT BE MADE PUBLIC OR COPIED. IT IS LOANED SUBJECT TO RETURN UPON DEMAND AND IS NOT TO BE USED DIRECTLY OR INDIRECTLY IN ANY WAY DETRIMENTAL TO THE INTERESTS OF J. C. PARDO & SONS, INC.	
DATE: 4/27/95	DATE: 2/21/97
BY: J. C. PARDO	BY: LAURIE TORI
TEMPERATURE SENSOR INSTALLATION	
SHEET 1 OF 1	REV. 8007

INSTALLATION OF NEW SCRAPER BLADE

WHEN INSTALLING A NEW SCRAPER BLADE THERE MAY BE SOME ADJUSTMENTS REQUIRED TO MAKE IT LAY FLAT TO FOLLOW THE CONTOUR OF THE KETTLE. IF THE BLADE DOES NOT FIT, YOU MAY HAVE TO GRIND EITHER THE TWO EDGES OF THE BLADE, OR THE CENTER OF THE BLADE (PER. DETAIL A).

NOTE # 1

WHEN THERE IS TOO MUCH OR TOO LITTLE PRESSURE ON THE SCRAPER BLADE, BEND THE BACK STOP DOWN TO DECREASE THE PRESSURE OR BEND IT UP TO INCREASE THE PRESSURE ON THE BLADE WHEN SCRAPING THE KETTLE SURFACE (PER. FIG. 1).

NOTE # 2

IF ONLY ONE CORNER OF THE SCRAPER BLADE IS TOUCHING THE KETTLE SURFACE, USE A CRESCENT WRENCH AND SLIGHTLY TWIST THE SCRAPER HOLDER SO THE ENTIRE BLADE SCRAPES THE KETTLE WALL WITH EVEN PRESSURE.

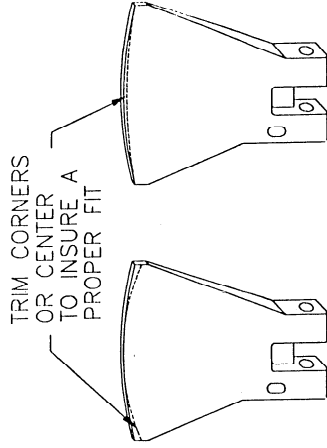
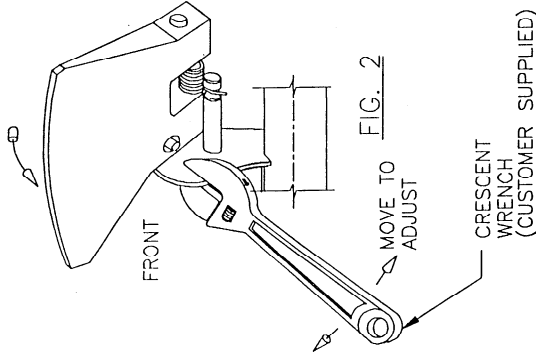
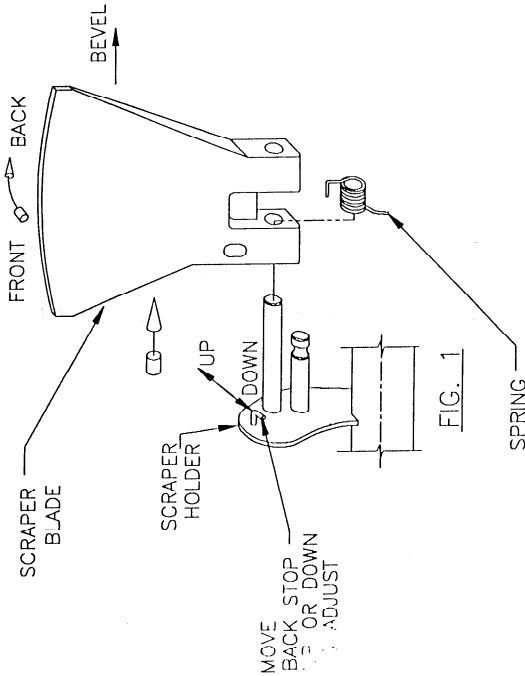

DETAIL A

JOB #

**J. C. PARDO & SONS INC.**  
 1250 REAMES RD. BALTO. MD. 21220  
 SCALE NONE APPROVED BY: *Hal G* 4/25/95 DRAWN BY: LAURIE YORI  
 DATE: 4/25/95  
 REPLACEMENT AND FITTING  
 SCRAPER BLADE & SPRING  
 SHEET 1 of 1 SIZE B DRAWING NUMBER 8230 REV. C

THIS DRAWING AND ALL INFORMATION CONTAINED THEREIN IS THE PROPERTY OF J. C. PARDO & SONS INC. BALTO. MD.. AND MUST NOT BE MADE PUBLIC OR COPIED. IT IS LOANED SUBJECT TO RETURN UPON DEMAND AND IS NOT TO BE USED DIRECTLY OR INDIRECTLY IN ANY WAY DETRIMENTAL TO THE INTERESTS OF J. C. PARDO & SONS INC.

## HORIZONTAL AGITATOR KETTLE OPERATIONS AND CLEANING INSTRUCTIONS

### CLEANING INSTRUCTIONS

As with all equipment that has electrical components, care must be exercised when using water and chemicals to clean food service equipment. Use a mild detergent following instructions of the chemical manufacturer. Do not spray water on electrical control panel or components. Do not use harsh or caustic chemicals, especially on o-rings and gaskets.

1. Rinse out food debris from the kettle and flush through the metering filling station (MFS or food pump) if they are still connected. If the kettle is not connected to the food pump, open the valve and allow rinse water to flush into the floor drain.
2. Remove agitator arm:
  - a. Rotate the agitator until the quick release pull pin is on the top.
  - b. Turn power to OFF as a safety precaution.
  - c. Pull pin out.
  - d. Slide coupling toward side of kettle.
  - e. Carefully lift end of agitator, pull back and lift out.
  - f. Remove bushing from shaft holder.
  - g. Remove scraper blades from agitator by using the spring removal tool provided with the kettle.
  - h. Wash agitator arm, scraper blades, and springs with mild dish detergent or in dish machine. Air dry.
3. Wash the inside of the kettle with a mild dish detergent as you would any pot or pan. Flush liquid through MFS or by opening the valve. Rinse thoroughly.
4. Remove the valve and tee from the bottom of the kettle by removing the clamp. Remove o-rings. Wash and dry thoroughly. When re-installing the valve, apply USDA approved food grade grease (Chesterton 622 or equal) to o-rings. Gently push tee and valve body in place and secure with clamps.
5. Clean outer drive shaft seal on the side of the kettle by removing thumb screws. Slide seal retainer plate and quad ring away from the kettle or shaft housing. Clean the shaft, seal and quad ring. Before re-installing, apply a liberal amount of USDA approved food grade grease to the opening around the shaft and slide quad ring back in place. Push the seal retainer plate back in place and tighten with thumb screws.
6. Remove temperature sensor probe by removing clamp. Slide sensor out of seal holder. Remove o-rings. Clean sensor, seal and o-rings. Before re-installing, apply a liberal amount of USDA approved food grade grease on o-rings.

## DAILY PRE-START UP

1. The operator must check the kettle, springs and scraper blades for proper installation before turning kettle on.
2. Make sure the connecting coupling from the drive shaft to the agitator is properly installed with the quick release pin fully engaged.
3. Label and place clean chart on chart recorder.

If the above cannot be achieved, call your maintenance supervisor or service contractor before proceeding.

## OPERATING INSTRUCTIONS HORIZONTAL MIXER KETTLE

Your kettle has been equipped with a control panel that has some or all of the following functions:

1. Main POWER switch
2. Temperature control
3. 24 hour chart recorder
4. KETTLE RUN push button
5. Agitator speed control with variable settings
6. Agitator STOP/START
7. Potable water meter with OFF/ON switch and push button to add water
8. Manual COOL water switch
9. Kettle selector switch for CONTINUOUS, OFF, COOK
10. SIMMER switch
11. Product VALVE OPEN/CLOSED

### Operating the Kettle

1. To operate the system the main power switch on the control panel must be turned on. The temperature control computer will run through its diagnostics for about one minute.
2. To set desired temperature, turn switch to COOK. This activates the temperature controller. The temperature displayer and the actual temperature will appear. To change the temperature set point, press the push button with “+” to raise or increase the temperature or press the button with “-“ to decrease or lower the temperature.
3. Push the button marked KETTLE RUN and the steam will come on to heat the kettle and its contents until the set point temperature is reached. It will cycle off and on to maintain the set point temperature.
4. To start the agitator, press the button marked AGITATOR START and a green light will indicate the agitator is on.
5. To stop the agitator, press the red AGITATOR STOP mushroom button.
6. To change the speed of the agitator, turn the SPEED CONTROL knob to the right to increase the speed or to the left to decrease the speed. As a safety precaution, always turn the speed to “0” when kettle is not in use and before use.

7. To add ingredients to the kettle, push AGITATOR STOP button. Steam heating will continue in the jacket and the agitator must be started again as soon as possible or product might burn on the surface of the kettle.
8. CONTINUOUS STEAM is a manual override allowing steam into the kettle but with no temperature control.
9. SIMMER allows maintenance to the set point temperature but gently introduces heat into the kettle.

#### Ready to pump food out of kettle

1. Foods must be cooked to a minimum of 165°F to kill dangerous pathogens and must be at least this temperature when it casings are filled. Set temperature on the control panel to at least 165°F before pumping.
2. Pump food through MFS to heat hoses and MFS parts until at least 165°F can be maintained when product exits the MFS. Product may be poured back into the kettle for reheating before pumping.
3. Put down cover of kettle to maintain heat and to maintain a moist atmosphere in the kettle which will make cleaning easier.
4. Empty the kettle as quickly as possible to prevent over-cooking of product and to maintain quality, consistency and temperature.
5. Temperature may be turned OFF or placed on SIMMER when kettle product reaches the steam jacketed area to reduce chances of burning while pumping.

#### To cool and blend products without heat

1. Turn the main power switch to ON.
2. Turn the MANUAL WATER COOLING switch to ON. This will start the flow of cold water from the ice builder into the jacket of the kettle. When in this mode the temperature controller will read the temperature of the product only and serve no other function.
3. When cooking a product that is too hot, MANUAL COOLING can be used. Turn on MANUAL COOLING. When sufficient cooling has been achieved, turn the switch off. The kettle jacket will drain and steam will automatically come on to continue cooking if the set point has not been lowered.

#### To add Potable water to the kettle

1. Faucet handle must be completely open and the main power must be on.
2. Set point the volume of water needed by changing the digits on the meter.
3. Turn METERED WATER switch to ON. Water will begin filling the desired number of gallons and stop automatically. The amount of water that has been metered can be read above the set point.
4. Additional water may be metered by resetting meter and will accumulate on the meter as long as it is not turned off.
5. Additional water may be added by pressing the black button marked PUSH TO ADD MORE WATER.

## PREVENTIVE MAINTENANCE

### COOK/CHILL MIXER & PASTA KETTLES

#### A. **AUTOMATIC DUMP VALVE**

##### **Weekly**

- Check air collector regulator for moisture, dirt, and proper pressure
- Check all orings and seals and gaskets
- Check valve operation
- Lubricate with light oil when needed
- Check air hose for leaks or signs of wear

#### B. **TILT MECHANISM ( Hydraulic Tilt )**

##### **Weekly**

- Check for leaks
- Check for smooth operation
- Check switches

##### **Yearly**

- Change hydraulic fluid every two years. (1 1/2 gallons of **FOOD GRADE** hydraulic fluid) ( Shell Telis #5 )

##### **( Electric Tilt )**

##### **Weekly**

- Check for smooth operation
- Check switches

##### **Monthly**

- Check for movement in mechanism
- Grease trunnions monthly ( **Food Grade Grease** )

#### C. **AIR PRESSURE**

##### **Weekly**

- 45 psi dump valve - 15 psi for jacket purge
- Air must be clean and dry
- Check all air lines & fittings for leaks

#### D. **STEAM TRAP**

##### **Monthly**

- Check proper operation

**PREVENTIVE  
MAINTENANCE**

**COOK/CHILL MIXER & PASTA KETTLES (continued)**

**E. SAFETY VALVE**

**Weekly**

- Check for leakage
- Steam pressure 65 psi. max.
- Safety set at 100 psi.

**F. LEAKS**

**Weekly**

- Check for leaks of any type ( water - steam - hydraulic )  
( **Leaks take away from performance and will lead to costly repair** )

**G. Control Panels**

**Weekly**

- Signs of water damage
- Check operation of all controls
- Water meter operation
- Temp read outs
- Temp charting
- Temp controlling
- RTD adjustments
- Mixer operation & speed control
- Gentle heat operation
- product valve operation

## **HAMKDL- 60 – CC-T**

- **Make sure kettle is level, equipment can move as floors settle**
- **Make sure kettle is bolted securely to floor, bolts may loosen after time**
- **Check the incoming power and amp draws (per rating plate)**
- **Check incoming air pressure (1" line 1cfm @ 90psi.)**
- **Check air pressure regulator/collector for draw off valve (45psi.)**
- **Check air pressure regulator for kettle jacket purge (15psi.)**
- **Check air collector regulator for moisture, dirt (Must be clean & dry)**
- **Check all o-rings and shaft seal for wear and proper lubrication**
- **Check the installation 3" Flush Piston Draw Off Valve**
- **Check all air hoses for leaks and signs of wear**
- **Check incoming steam pressure (3/4"line / 320PPM / 65psi.)**
- **Check the steam trap for proper operation (clean or replace if needed)**
- **Check the operation of safety valve 100psi. rating**
- **Check for steam leaks (Inlets and Returns)**
- **Check for the proper clearance where drive shaft penetrates the kettle**
- **Make sure temperature sensor is properly installed**
- **Check chill water supply and return lines for leaks.**
- **Check the control panel for any signs of corrosion moisture**
- **Check the complete operation of all kettle controls**
- **Check the mixer operation (Speed control, Emergency stop)**
- **Check the idler bearing and idler busing for wear**
- **Check the kettle tilt (up and down)**
- **Check hydraulic fluid level**
- **Check hydraulic lines for leaks and signs of wear**
- **Change hydraulic fluid yearly (ISO 46 20 weight Food Grade)**
- **Grease tilt mechanism monthly (Food grade grease)**
- **Check the operation of 3" Flush Piston Draw Off Valve**
- **Check water meter operation**
- **Make sure the Partlow chart recorder/controller is controlling, reading, and charting correctly**
- **Check the cooking operation in both automatic and in manual modes**
- **Check the operation of gentle heat mode**
- **Check the operation of the chill mode**
- **Check kettle cover hinge tension and fasteners**

## **HA-MKDL-100-CC-T**

- Make sure kettle is level, equipment can move as floors settle
- Make sure kettle is bolted securely to floor, bolts may loosen after time
- Check the incoming power and amp draws (per rating plate)
- Check incoming air pressure (1" line 1cfm @ 90psi.)
- Check air pressure regulator/collector for draw off valve (45psi.)
- Check air pressure regulator for kettle jacket purge (15psi.)
- Check air collector regulator for moisture, dirt (Must be clean & dry)
- Check all o-rings and shaft seal for wear and proper lubrication
- Check the installation 3" Flush Piston Draw Off Valve
- Check all air hoses for leaks and signs of wear
- Check incoming steam pressure (3/4"line / 320PPM / 65psi.)
- Check the steam trap for proper operation (clean or replace if needed)
- Check the operation of safety valve 100psi. rating
- Check for steam leaks (Inlets and Returns)
- Check for the proper clearance where drive shaft penetrates the kettle
- Make sure temperature sensor is properly installed
- Check chill water supply and return lines for leaks.
- Check the control panel for any signs of corrosion moisture
- Check the complete operation of all kettle controls
- Check the mixer operation (Speed control, Emergency stop)
- Check the idler bearing and idler busing for wear
- Check the kettle tilt (up and down)
- Check hydraulic fluid level
- Check hydraulic lines for leaks and signs of wear
- Change hydraulic fluid yearly (ISO 46 20 weight Food Grade)
- Grease tilt mechanism monthly (Food grade grease)
- Check the operation of 3" Flush Piston Draw Off Valve
- Check water meter operation
- Make sure the Partlow chart recorder/controller is (controlling, reading, and charting correctly)
- Check the cooking operation in both automatic and in manual modes
- Check the operation of gentle heat mode
- Check the operation of the chill mode
- Check kettle cover hinge tension and fasteners

## **HA-MKDL-200-CC-T**

- Make sure kettle is level, equipment can move as floors settle
- Make sure kettle is bolted securely to floor, bolts may loosen after time
- Check the incoming power and amp draws (per rating plate)
- Check incoming air pressure (1" line 1cfm @ 90psi.)
- Check air pressure regulator/collector for draw off valve (45psi.)
- Check air pressure regulator for kettle jacket purge (15psi.)
- Check air collector regulator for moisture, dirt (Must be clean & dry)
- Check all o-rings and shaft seal for wear and proper lubrication
- Check the installation 3" Flush Piston Draw Off Valve
- Check all air hoses for leaks and signs of wear
- Check incoming steam pressure (3/4"line / 320PPM / 65psi.)
- Check the steam trap for proper operation (clean or replace if needed)
- Check the operation of safety valve 100psi. rating
- Check for steam leaks (Inlets and Returns)
- Check for the proper clearance where drive shaft penetrates the kettle
- Make sure temperature sensor is properly installed
- Check chill water supply and return lines for leaks.
- Check the control panel for any signs of corrosion moisture
- Check the complete operation of all kettle controls
- Check the mixer operation (Speed control, Emergency stop)
- Check the idler bearing and idler busing for wear
- Check the kettle tilt (up and down)
- Check hydraulic fluid level
- Check hydraulic lines for leaks and signs of wear
- Change hydraulic fluid yearly (ISO 46 20 weight Food Grade)
- Grease tilt mechanism monthly (Food grade grease)
- Check the operation of 3" Flush Piston Draw Off Valve
- Check water meter operation
- Make sure the Partlow chart recorder/controller is (controlling, reading, and charting correctly)
- Check the cooking operation in both automatic and in manual modes
- Check the operation of gentle heat mode
- Check the operation of the chill mode
- Check kettle cover hinge tension and fasteners

## **HA-MKDL-300-CC-T**

- **Make sure kettle is level, equipment can move as floors settle**
- **Make sure kettle is bolted securely to floor, bolts may loosen after time**
- **Check the incoming power and amp draws (per rating plate)**
- **Check incoming air pressure (1" line 1cfm @ 90psi.)**
- **Check air pressure regulator/collector for draw off valve (45psi.)**
- **Check air pressure regulator for kettle jacket purge (15psi.)**
- **Check air collector regulator for moisture, dirt (Must be clean & dry)**
- **Check all o-rings and shaft seal for wear and proper lubrication**
- **Check the installation 3" Flush Piston Draw Off Valve**
- **Check all air hoses for leaks and signs of wear**
- **Check incoming steam pressure (3/4"line / 320PPM / 65psi.)**
- **Check the steam trap for proper operation (clean or replace if needed)**
- **Check the operation of safety valve 100psi. rating**
- **Check for steam leaks (Inlets and Returns)**
- **Check for the proper clearance where drive shaft penetrates the kettle**
- **Make sure temperature sensor is properly installed**
- **Check chill water supply and return lines for leaks.**
- **Check the control panel for any signs of corrosion moisture**
- **Check the complete operation of all kettle controls**
- **Check the mixer operation (Speed control, Emergency stop)**
- **Check the idler bearing and idler busing for wear**
- **Check the kettle tilt (up and down)**
- **Check hydraulic fluid level**
- **Check hydraulic lines for leaks and signs of wear**
- **Change hydraulic fluid yearly (ISO 46 20 weight Food Grade)**
- **Grease tilt mechanism monthly (Food grade grease)**
- **Check the operation of 3" Flush Piston Draw Off Valve**
- **Check water meter operation**
- **Make sure the Partlow chart recorder/controller is(controlling, reading, and charting correctly)**
- **Check the cooking operation in both automatic and in manual modes**
- **Check the operation of gentle heat mode**
- **Check the operation of the chill mode**
- **Check kettle cover hinge tension and fasteners**