

U-H1/U-HB

TO CUSTOMERS DISCONNECT SWITCH

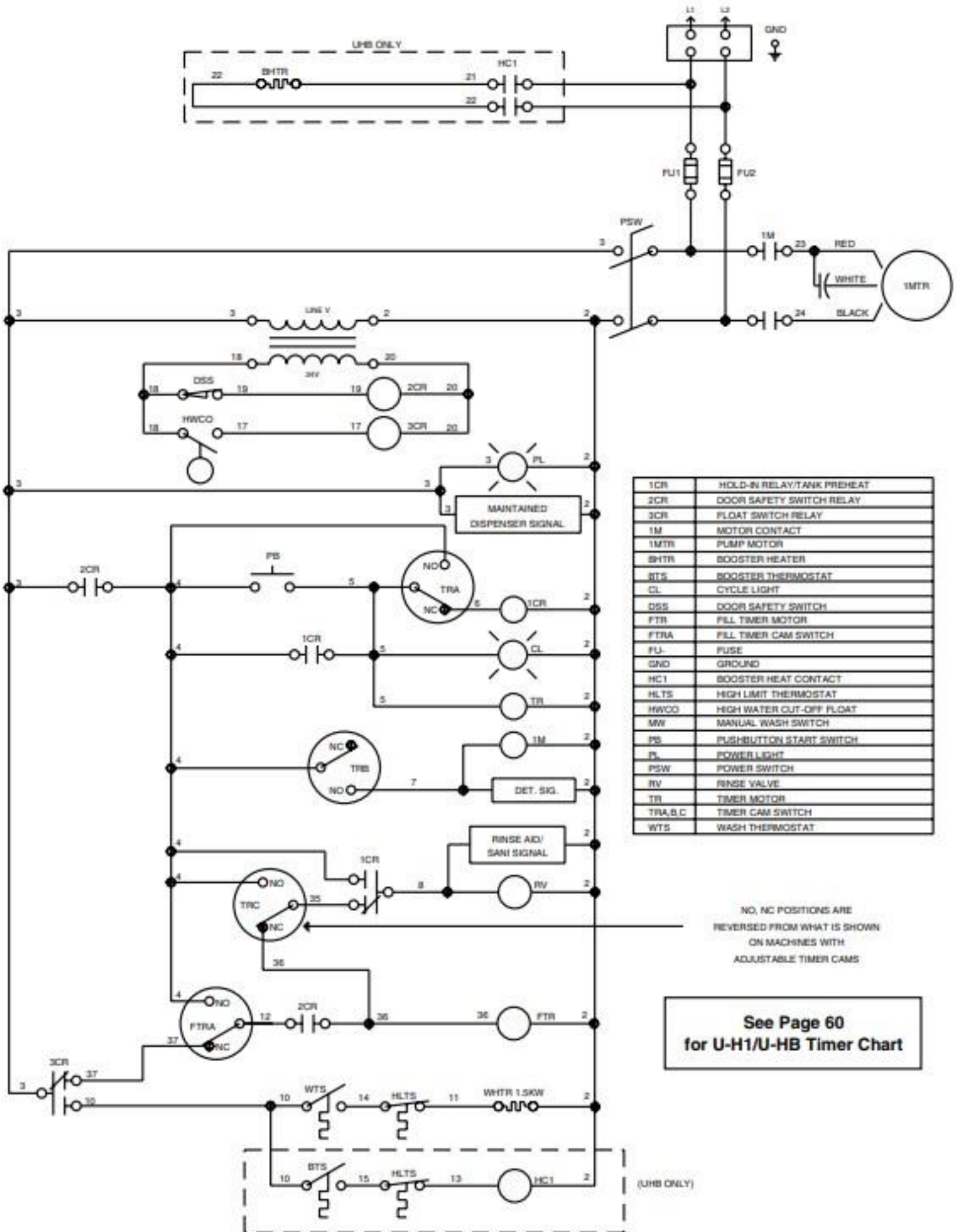
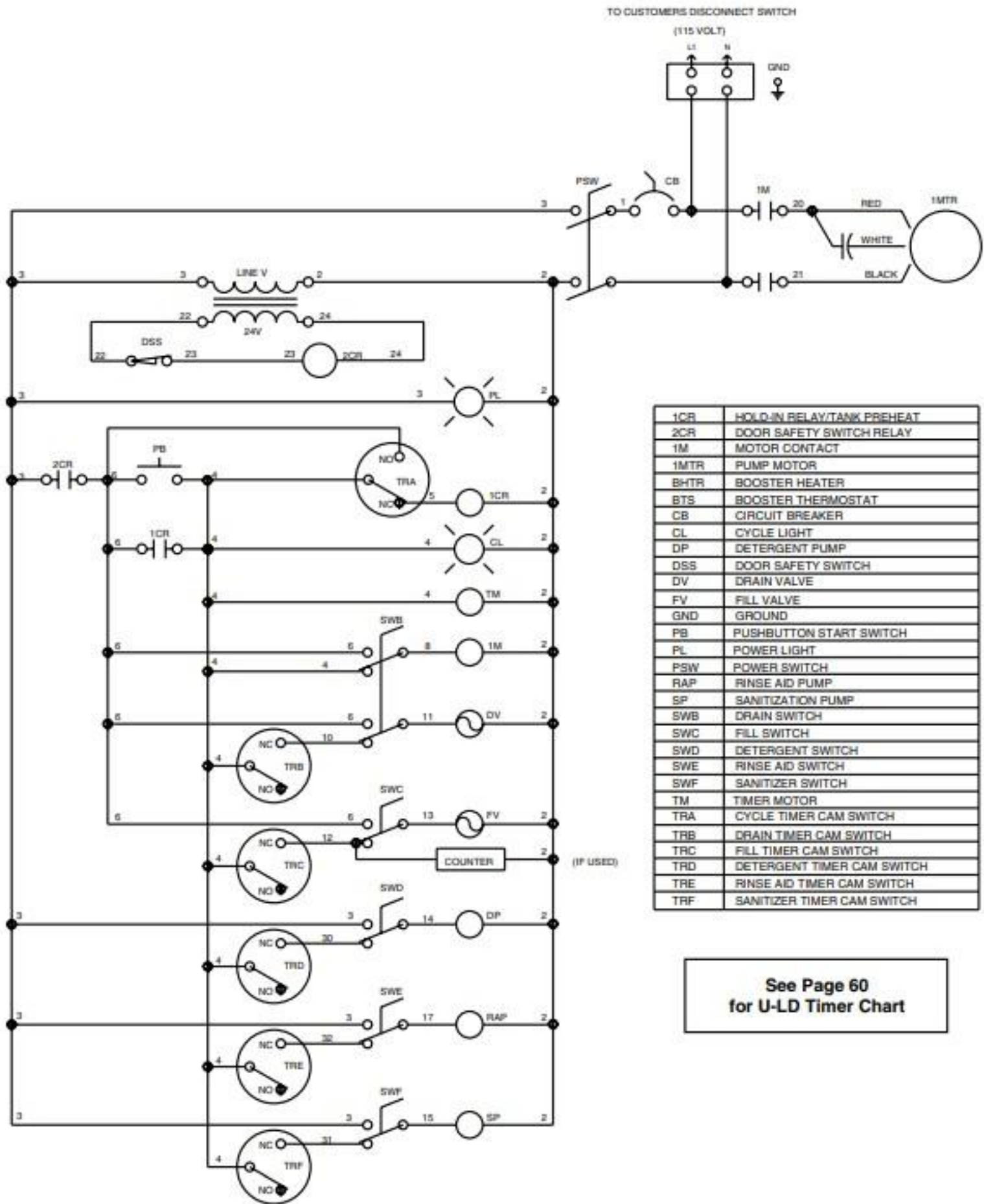

Figure 26 - U-H1/U-HB Electrical Schematic



1CR	HOLD-IN RELAY/TANK PREHEAT
2CR	DOOR SAFETY SWITCH RELAY
1M	MOTOR CONTACT
1MTR	PUMP MOTOR
BHTR	BOOSTER HEATER
BTS	BOOSTER THERMOSTAT
CB	CIRCUIT BREAKER
CL	CYCLE LIGHT
DP	DETERGENT PUMP
DSS	DOOR SAFETY SWITCH
DV	DRAIN VALVE
FV	FILL VALVE
GND	GROUND
PB	PUSHBUTTON START SWITCH
PL	POWER LIGHT
PSW	POWER SWITCH
RAP	RINSE AID PUMP
SP	SANITIZATION PUMP
SWB	DRAIN SWITCH
SWC	FILL SWITCH
SWD	DETERGENT SWITCH
SWE	RINSE AID SWITCH
SWF	SANITIZER SWITCH
TM	TIMER MOTOR
TRA	CYCLE TIMER CAM SWITCH
TRB	DRAIN TIMER CAM SWITCH
TRC	FILL TIMER CAM SWITCH
TRD	DETERGENT TIMER CAM SWITCH
TRE	RINSE AID TIMER CAM SWITCH
TRF	SANITIZER TIMER CAM SWITCH

**See Page 60
for U-LD Timer Chart**

Figure 27 - U-LD Electrical Schematic