

Champion[®]

The Dishwashing Machine Specialists

Technical Manual



**Gas Fired
Boiler**

**Model
CSS-130**

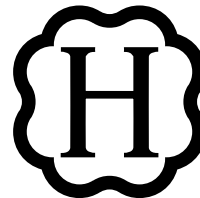

CAUTION

Read all instructions carefully before starting the installation.
Save this manual for future reference

July, 1997

Manual P/N 111995 REV. A

P. O. Box 4149
Winston-Salem, North Carolina 27115-4149
336/661-1556 Fax: 336/661-1660

2674 N. Service Road
Jordan Station, Ontario, Canada LOR 1S0
905/562-4195 Fax: 905/562-4618

Champion Industries, Inc.

TO THE INSTALLER: BEFORE YOU BEGIN

It is important for you to read all Installation and Operating sections of this manual before you begin installation. This will avoid mistakes and confusion when installing and operating the unit.

- | | |
|---------------------------------|--------------------------------|
| 1. Gas Burner | 10. Blower Motor and Housing |
| 2. Air Intake | 11. Control Cabinet |
| 3. Outside Vent Wall | 12. Tank Vent |
| 4. Exhaust Air | 13. Coil Air Bleed Off |
| 5. Dishwasher Water Supply | 14. Circulation Pump |
| 6. Water Return From Dishwasher | 15. Expansion Tank |
| 7. Gas Supply | 16. Terminal Strip |
| 8. Gas Valve | 17. Boiler Control |
| 9. Stack Switch | 18. Transformer 24V |
| | 19. Copper Coil Heat Exchanger |

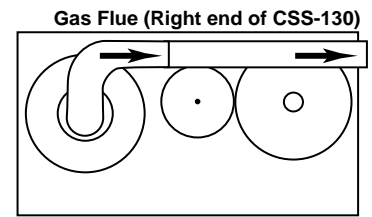
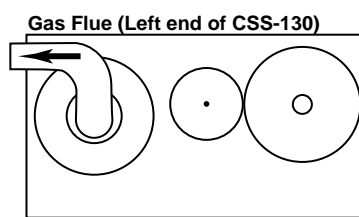
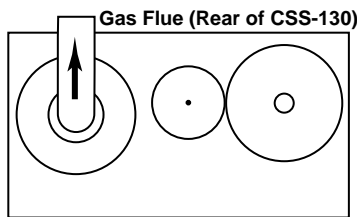
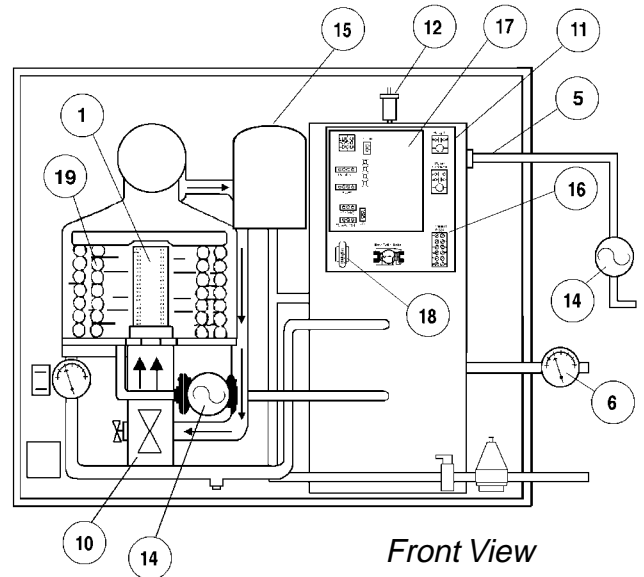
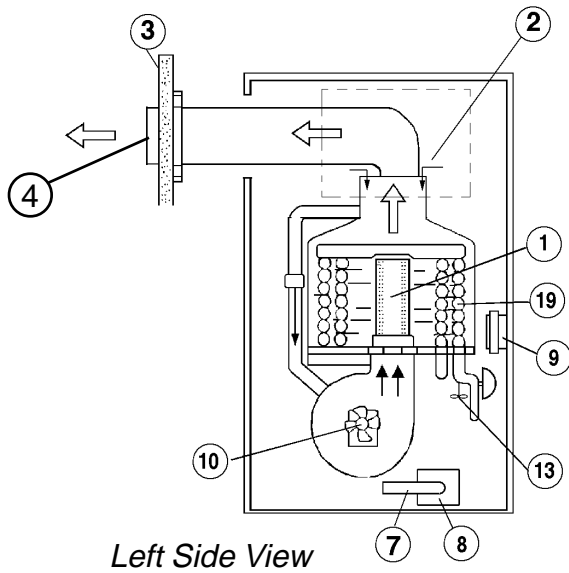

NOTE:

The CSS-130 is available in (3) venting configurations: rear, left, or right direction. Gas flue venting configurations are specified at the time of order.

Figure 1
Component Locator

Revision History

Revision Date	Revised Pages	Serial Number Effectivity	Comments
7/7/97	All	—	Reissue of manual and replacement parts lists

CONTENTS

LIMITED WARRANTY 1

INTRODUCTION 2

 Unpacking the Gas Fired Boiler 3

 Installation Codes 3

 Locating the Gas Fired Boiler 3

 Clearance to Combustibles 4

 Air for Combustion and Ventilation 5

INSTALLATION 6

 VENT INSTALLATION 6

 General 6

 Existing Boiler Removal 6

 Common Venting 7

 Vertical Venting 8

 Chimney Venting 10

 Horizontal Through-the-Wall Venting 14

 Pipe Cutting and Joining Procedures 15

 Locating the Vent Opening in the Outside Wall 16

 Installing the Horizontal Venting and Termination 17

 GAS SUPPLY CONNECTIONS 18

 Gas Fuel Requirements 18

 Gas Pressure Requirements 18

 Gas Piping Installation 19

 Pressure Testing the Gas Piping Installation 20

 Field Conversion of Gas Orifice 21

 ELECTRICAL CONNECTIONS 22

 PLUMBING CONNECTIONS 24

 Water and Drain Connections 24

INITIAL START-UP AND SERVICE 25

 Instructions for Setting Air Pressure in Expansion Tank 26

 Instructions for Manually Venting Air from Boiler Water System 27

 Gas Valve Operating Instructions 28

 Check Test, and Start-up 29

 Sequence of Operation Explained 36

TROUBLESHOOTING FLOW CHARTS 37

ELECTRICAL SCHEMATICS 45

REPLACEMENT PARTS LIST 48

LIST OF FIGURES

Figure 1 – Component Locator	i
Figure 2 – Minimum Clearance to Combustibles (Top View)	4
Figure 3 – Minimum Clearance to Combustibles (Front View)	4
Figure 4 – Clearance Dimensions Chart	4
Figure 5 – Vent Pipe Slope and Horizontal Support	8
Figure 6 – Vertical Through-the-Roof Vent Installation with Fire Stops	9
Figure 7 – Vertical Vent Configuration	9
Figure 8 – Type B-1 Vent Chimney Venting Detail	11
Figure 9 – Type B-1 Chimney Vent Connection without Elbows	12
Figure 10 – Type B-1 Chimney Vent Connection with Elbows	12
Figure 11 – Horizontal Through-the Wall Venting	14
Figure 12 – Horizontal Vent (Exit Through Rear Wall)	16
Figure 13 – Horizontal Termination Clearance	16
Figure 14 – Horizontal Vent Termination (Window and Grade Level)	17
Figure 15 – Horizontal Vent (Exit Through Side Wall)	17
Figure 16 – Pipe Sizing Table	19
Figure 17 – Gas Supply Piping (Drip Leg)	19
Figure 18 – CSS-130 Manual Gas Shut-off Valve	20
Figure 19 – CSS-130 Gas Connection Point (Side View)	20
Figure 20 – CSS-130 Gas Connection Point (Top View)	20
Figure 21 – Gas Orifice Union Location	21
Figure 22 – Gas Orifice Union	21
Figure 23 – LP Gas Orifice Kit P/N 111993	21
Figure 24 – Electrical Connections (Right side of CSS-130)	22
Figure 25 – Electrical Schematic Detail	23
Figure 26 – CSS-130 Control Panel Power Connections (Inside right front side)	23
Figure 27 – Plumbing Connections (Right side of CSS-130)	24
Figure 28 – Electrical Diagrams	46
Figure 29 – Parts Diagrams	48

LIMITED WARRANTY

Champion Industries Inc. (herein referred to as Champion), P.O. Box 4149, Winston-Salem, North Carolina 27115, and P.O. Box 301, 2674 North Service Road, Jordan Station, Ontario, Canada L0R 1S0 warrants machines, and parts, as set out below.

Warranty of Machines: Champion warrants all new machines of its manufacture bearing the name "Champion" and installed within the United States and Canada to be free from defects in material and workmanship for a period of one (1) year after the date of installation or fifteen (15) months after the date of shipment by Champion, whichever occurs first. [See below for special provisions relating to glasswashers.] The warranty registration card must be returned to Champion within ten (10) days after installation. If warranty card is not returned to Champion within such period, the warranty will expire after one year from the date of shipment.

Champion will not assume any responsibility for extra costs for installation in any area where there are jurisdictional problems with local trades or unions.

If a defect in workmanship or material is found to exist within the warranty period, Champion, at its election, will either repair or replace the defective machine or accept return of the machine for full credit; provided, however, as to glasswashers, Champion's obligation with respect to labor associated with any repairs shall end (a) 120 days after shipment, or (b) 90 days after installation, whichever occurs first. In the event that Champion elects to repair, the labor and work to be performed in connection with the warranty shall be done during regular working hours by a Champion authorized service technician. Defective parts become the property of Champion. Use of replacement parts not authorized by Champion will relieve Champion of all further liability in connection with its warranty. In no event will Champion's warranty obligation exceed Champion's charge for the machine. The following are not covered by Champion's warranty:

- a. Lighting of gas pilots or burners.
- b. Cleaning of gas lines.
- c. Replacement of fuses or resetting of overload breakers.
- d. Adjustment of thermostats.
- e. Adjustment of clutches.
- f. Opening or closing of utility supply valves or switching of electrical supply current.
- g. Cleaning of valves, strainers, screens, nozzles, or spray pipes.
- h. Performance of regular maintenance and cleaning as outlined in operator's guide.
- i. Damages resulting from water conditions, accidents, alterations, improper use, abuse, tampering, improper installation, or failure to follow maintenance and operation procedures.
- j. Wear on Pulper cutter blocks, pulse vanes, and auger brush.

Examples of the defects not covered by warranty include, but are not limited to: (1) Damage to the exterior or interior finish as a result of the above, (2) Use with utility service other than that designated on the rating plate, (3) Improper connection to utility service, (4) Inadequate or excessive water pressure, (5) Corrosion from chemicals dispensed in excess of recommended concentrations, (6) Failure of electrical components due to connection of chemical dispensing equipment installed by others, (7) Leaks or damage resulting from such leaks caused by the installer, including those at machine table connections or by connection of chemical dispensing equipment installed by others, (8) Failure to comply with local building codes, (9) Damage caused by labor dispute.

Warranty of Parts: Champion warrants all new machine parts produced or authorized by Champion to be free from defects in material and workmanship for a period of 90 days from date of invoice. If any defect in material and workmanship is found to exist within the warranty period Champion will replace the defective part without charge.

DISCLAIMER OF WARRANTIES AND LIMITATIONS OF LIABILITY. CHAMPION'S WARRANTY IS ONLY TO THE EXTENT REFLECTED ABOVE. CHAMPION MAKES NO OTHER WARRANTIES, EXPRESS OR IMPLIED, INCLUDING, BUT NOT LIMITED, TO ANY WARRANTY OF MERCHANTABILITY, OR FITNESS OF PURPOSE. CHAMPION SHALL NOT BE LIABLE FOR INCIDENTAL OR CONSEQUENTIAL DAMAGES. THE REMEDIES SET OUT ABOVE ARE THE EXCLUSIVE REMEDIES FOR ANY DEFECTS FOUND TO EXIST IN CHAMPION DISHWASHING MACHINES AND CHAMPION PARTS, AND ALL OTHER REMEDIES ARE EXCLUDED, INCLUDING ANY LIABILITY FOR INCIDENTALS OR CONSEQUENTIAL DAMAGES.

Champion does not authorize any other person, including persons who deal in Champion dishwashing machines to change this warranty or create any other obligation in connection with Champion Dishwashing Machines.

INTRODUCTION

Welcome to **Champion...**
and thank you for allowing us to take care of your dishwashing needs.

This manual covers the Champion Single Source Gas Fired Boiler, Model CSS-130.

The CSS-130 operates in conjunction with the Champion door-type dishwasher model D-HB and the rack conveyor dishwasher model 44-WS and 66-WS

The CSS-130 is a low pressure gas fired boiler capable of supplying hot water to the dishwasher wash tank heating coil for wash tank heat and 180°F final rinse water for sanitizing.

Your gas fired boiler was completely assembled, inspected, and thoroughly tested at our factory before it was shipped to your installation site.

This manual contains:

- Installation Instructions
- Operation Instructions
- Maintenance Instructions
- Service Instructions
- Replacement Parts Lists
- Electrical Schematics

All information, illustrations and specifications contained in this manual are based upon the latest product information available at the time of publication. **Champion** constantly improves its products and reserves the right to make changes at any time or to change specifications or design without notice and without incurring any obligation.

For your protection, factory authorized parts should always be used for repairs.

Replacement parts may be ordered directly from your **Champion** authorized parts distributor or authorized service agency. When ordering parts, please supply the model number, serial number, voltage, and phase of your machine, the part number, part descriptions and quantity.

Unpacking the Gas Fired Boiler



CAUTION:

Care should be taken when lifting the machine to prevent damage.

1. Immediately after unpacking the machine, inspect for any shipping damage.
If damage is found, save the packing material and contact the carrier immediately.
2. Remove the gas fired boiler from the skid.
Move the boiler to its permanent location.

Installation Codes

The installation of this unit must conform to local codes or, in the absence of local code, to the National Fuel Gas Code, ANSI Z223.1-Latest Edition. Where required by the authority having jurisdiction, the installation also must conform to the Standards for Controls and Safety Devices for Automatically Fired Boilers, ANSI/ASME CSD-1.

For Canada, the installation of this unit must conform to all Canadian local codes as applicable or, in the absence of local codes, to the Canadian installation code, CAN/CGA-B149, and CSA C22.1 Canadian Electrical Code Part 1.

Locating the Gas Fired Boiler

Locate the gas fired boiler as near to the exhaust venting system as practical. Air openings on the front, back and sides of the boiler housing should not be obstructed since they supply air to the combustion chamber.

The location of the boiler should be chosen with regard to venting dimensions, convenient access to piping, ventilation of operating components and accessibility for service and cleaning.

The boiler shall be installed such that the gas ignition system components are protected from water (dripping, spraying, rain, etc.) during appliance operation and servicing procedures such as pump replacement, burner cleaning and the like.

When the unit is located in an unconfined space of a building, air infiltration may be adequate to provide air for combustion and ventilation. Where normal infiltration does not provide the necessary air, outside air must be introduced.

In buildings of unusually tight construction, or when locating the unit in a confined space, additional air must be provided. For confined spaces, two (2) permanent openings shall be provided:

One (1) opening within 12" of the ceiling and one (1) within 12" of the floor of the enclosing space. Each opening shall be at least 1 square inch per 1,000 BTU/HR heater input of the total for all appliances in the area, but not less than 100 square inches. These openings shall freely connect with areas having adequate infiltration from outside.

The boiler should be placed beside the Champion dishwasher model that it serves so that all plumbing and electrical connections between the boiler and the dishwasher can be made per Champion's specifications.

If installed in a finished area, provisions should be made for drainage of any accidental spillage or leakage of water. The boiler pressure relief valve and back-flow preventor should be piped to a drain to protect from the occasional discharge of water.

INTRODUCTION (CONT'D)

Locating the Gas Fired Boiler (Cont'd)

Clearance to Combustibles

The CSS-130 is certified by the American Gas Association, (AGA), and the Canadian Gas Association (CGA), for installation on combustible flooring. The CSS-130 is rated for alcove installation.

NOTE:

DO NOT INSTALL THE GAS FIRED BOILER ON CARPETING.

Refer to Fig. 2-4 below for the minimum allowable clearances to combustible and noncombustible materials.

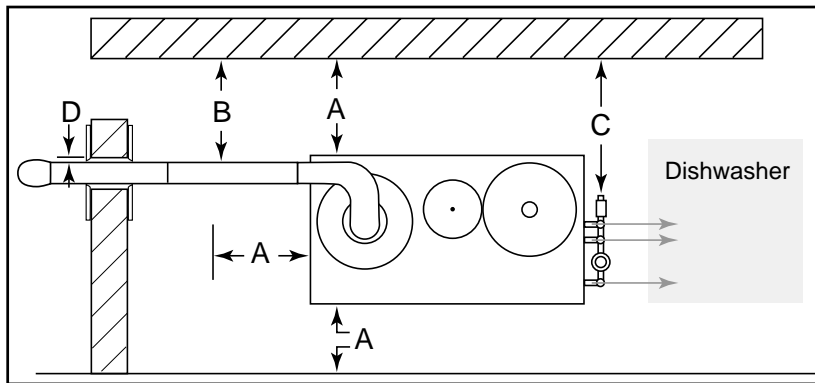

Figure 2
Minimum Clearance
to Combustibles
CSS-130
Top View
(Horizontal Vent Arrangement Shown)

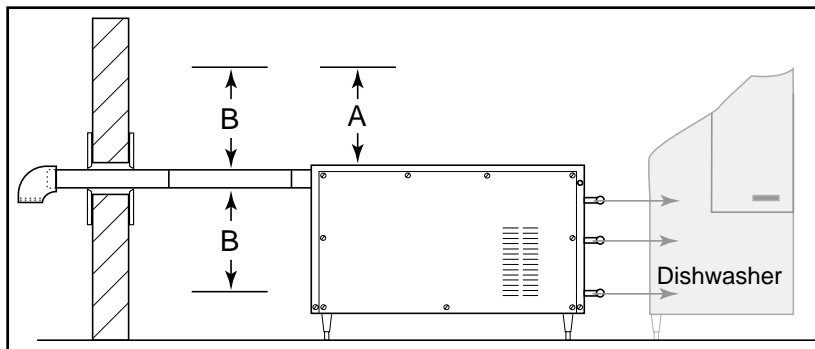

Figure 3
Minimum Clearance
to Combustibles
CSS-130
Front View
(Horizontal Vent Arrangement Shown)

CLEARANCE TO COMBUSTIBLES

(Dimensions in Inches)

Location	Item	Minimum Clearance
A	Boiler to Top, Back, & Side Walls	1 inch
B	Double wall Type B-1 Vent	1 inch
	Single Wall SST or Galvanized Vent	6 inches
C	Hot Water Pipes	3 inches
D	Through Combustible Wall	2 inches

Figure 4
Clearance Dimensions Chart
(See Fig. 2-3 above)

Clearance to Combustibles (Cont'd)

The clearances listed in the Clearance Chart (See Fig. 4) are minimum clearances. Clearances for service accessibility to the gas fired boiler must take preference over the fire protection clearances. The installer should allow a minimum of 12" for servicing at the sides and back of the boiler if possible.



WARNING:

Provide a screen or other type of protective barrier around exposed vent pipe to reduce burn hazards where inadvertent contact with hot vent surfaces by personnel can occur.

Air for Combustion and Ventilation

General

An adequate supply of air for combustion and ventilation must be supplied in accordance with Section 5.3 of the National Fuel and Gas Code, ANSI Z223.1-Latest Edition or applicable provisions of the local building codes for gas utilization equipment installed in buildings that require air for combustion, ventilation, and the dilution of flue gases from within the building.

For Canada, the installation of this unit must conform to all Canadian local codes as applicable or, in the absence of local codes, to the Canadian installation code, CAN/CGA-B149.

Install the equipment in a location where the ventilation facilitates the satisfactory combustion of gas, proper venting and maintenance of ambient temperature at safe limits under normal conditions of use.

Equipment should be located so as not to interfere with proper air circulation.

When normal infiltration does not provide the necessary air, outside air must be introduced.

In addition to air needed for combustion, process air must be provided as required for: cooling of equipment or material, controlling the dew point, heating, drying, oxidation or dilution, safety exhaust, odor control, and air for compressors.

In addition to air needed for combustion, ventilation air must also be supplied, including all air required for comfort and proper working conditions for personnel.

Unconfined Space

An unconfined space (such as an open basement) must have a minimum volume of 50 cubic feet per 1,000 BTU/HR input of the total of all appliances in the area. Adjoining rooms may be counted as one area only if there are no doors between the rooms.

Air Contaminants

Compounds bearing contaminants such as chloride, fluoride, iodide, and bromide, when present in certain concentrations in the air supplied for combustion to the boiler, can result in an accelerated and severe corrosion condition in the heat exchanger and/or the venting systems. Avoid storing or using chemicals containing these compounds in the vicinity of the boiler if at all possible.



CAUTION:

Combustion air must not be contaminated by corrosive chemical fumes which can damage the heat exchanger in the boiler.

INSTALLATION



WARNING:

Read all of the instructions included with your machine before attempting any installation. Faulty vent installation can cause improper operation of the gas fired boiler.

Vent Installation

General

The CSS-130 gas fired boiler is approved as a Category I Boiler when the following vent installations are used:

1. Common vent installation
2. Vertical through-the-roof vent installation
3. Masonry chimney vent installation using Type B-1 Double-wall vent.

The CSS-130 is approved as a Category III Boiler when a horizontal through-the-wall vent installation is used. This installation is a positive pressure venting system and requires that all connections be sealed with an approved high temperature sealant.

Refer to the specific venting installation section for detailed instructions.

Vent installation must be in compliance with Part 7 "Venting of Equipment", of the National Fuel Gas Code; ANSI Z223.1-Latest Edition, (In Canada, to the Canadian installation code, CAN/CGA-B149), local codes, or ordinances, these instructions, and good trade practices.

Existing Boiler Removal

When an existing boiler is removed from a venting system serving other appliances, the venting system is likely to be too large to properly vent the remaining attached appliances. Perform the following steps individually with each appliance that remains connected to the common vent system placed in operation with the other appliances remaining connected to the common venting system but not in operation.

If improper venting is observed during any of the following tests, the common venting system must be corrected.

1. Seal any unused openings in the common venting system.
2. Visually inspect the vent system for proper size and horizontal pitch and determine that there is no blockage or restriction, leakage, corrosion, and other deficiencies which could cause an unsafe condition.
3. As far as practical, close all building doors and windows plus all doors between the space which the appliances remain connected to the common vent system are located and the other spaces of the building.

Existing Boiler Removal (Cont'd)

4. Turn on clothes dryers and any appliance NOT connected to the common vent system. Turn on any exhaust fans, such as range hoods and bathroom exhausts so they will operate at maximum speed. **DO NOT operate a summer exhaust fan.** Close fireplace dampers.
5. Follow the lighting instructions of the appliance being tested and place the appliance in operation. Adjust the thermostat so the appliance operates continuously.
6. After five minutes of main burner operation, test for air spillage at the draft hood relief opening. Use the flame of a match or candle, or the smoke from a cigarette, cigar, or pipe.
7. Repeat steps for each appliance connected to the common vent system.

After it has been determined that each appliance remaining connected to the common vent system properly vents when tested as outlined above, return all doors, windows, exhaust fans, fireplace dampers, and any other gas burning appliance to their previous conditions of use.

If necessary the common vent should be re-sized to approach the minimum size as determined by using the appropriate tables in Appendix G in the National Fuel Gas Code, ANSI Z223.1-Latest Edition.

For Canada, the installation of this unit must conform to all Canadian local codes as applicable or, in the absence of local codes, to the Canadian installation code, CAN/CGA-B149.

The boiler should not be connected to a chimney flue serving a separate appliance that is designed to burn solid fuel.

No portion of the venting system can extend into, or pass through any circulating air duct or plenum.

All vent pipe passing through floors, walls, and ceilings must be installed with the listed clearance to combustible materials and be fire stopped according to local codes.

Common Venting

Vent connectors serving Category I appliances shall not be connected to any portion of the mechanical draft systems operating under **positive** pressure such as Category III or Category IV venting systems.

When two or more vent connectors enter a common gas vent, chimney flue, or a single-wall metal pipe, the smaller of the connectors shall enter at the highest level consistent with the available headroom or clearance to combustible material.

Vent connectors shall be firmly attached to draft hood outlets or flue collars by sheet metal screws or other approved means, except vent connectors of listed Type B-1 vent material (which shall be assembled in accordance with the vent manufacturer's instructions). Fasten joints between sections of single-wall connector piping with sheet metal screws or other approved means.

INSTALLATION (CONT'D)

Vent Installation

Common Venting (Cont'd)

Horizontal portions of the venting system must be supported at least every 5 feet with metal straps to prevent sagging. All horizontal sections of the vent connection must slope upwards 1/4 inch per foot from the boiler to the vent termination (See Figure 5 below).

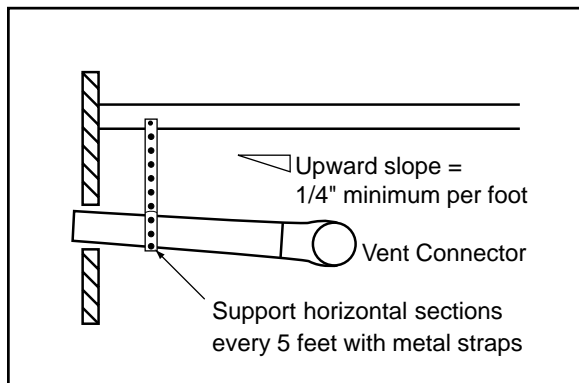

Figure 5
Vent Pipe Slope
and
Horizontal Support

The vent connector should be routed to the vent using the shortest route possible.

The entire length of a vent connector shall be readily accessible for inspection, cleaning, and replacement.

Vertical Venting

The CSS-130 is certified for use with up to 50 equivalent feet of 3" diameter pipe for vertical vent installations. A 90° elbow equals 5 equivalent feet of pipe.

Vent pipe and fittings must be securely supported horizontal sections require supports every 5 feet. Fire stops can support up to ten feet of vertical run.

Galvanized or stainless steel vent pipe may be used for vertical runs. Stainless steel vent pipe **must** be used for horizontal runs.

Saf-T Vent® manufactured by Heat Fab, Inc., is constructed from AL294C stainless steel and is approved for use in the United States and Canada.

Vertical Venting (Cont'd)

Maintain six inches (6") air space to combustible around the pipe for single wall metal vent.

Maintain one inch (1") air space to combustible around pipe for Type B-1 vent.

Whenever possible, the vent should be continued straight up through the roof. If it is necessary to make an offset in the attic, the horizontal run should slope upwards minimum of 1/4 inch per foot and be supported by metal straps.

Vent pipe passing through floors, ceilings, or framed walls must be fire stopped at floors and ceilings. The fire stop must close-in the area between the outside of the vent and the opening in the structure. Fire stops and supports can be purchased from Plexco Inc., or Hart and Cooley Inc.

When the vent passes through the roof, a flashing and storm collar must be used. Seal the storm collar to the pipe using a high temperature sealant. Terminations must be used in all installations above the roof to ensure the proper performance of the boiler and to prevent the entrance of debris. Type B-1 gas vents shall terminate above the roof surface with a U.L. listed cap or roof assembly.

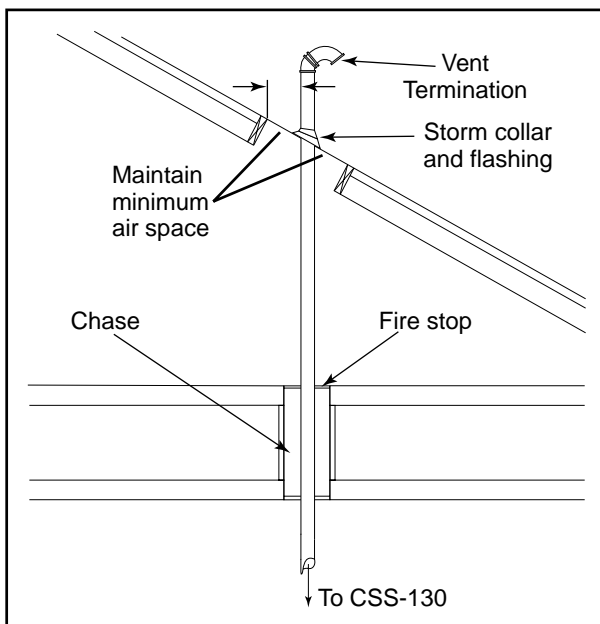
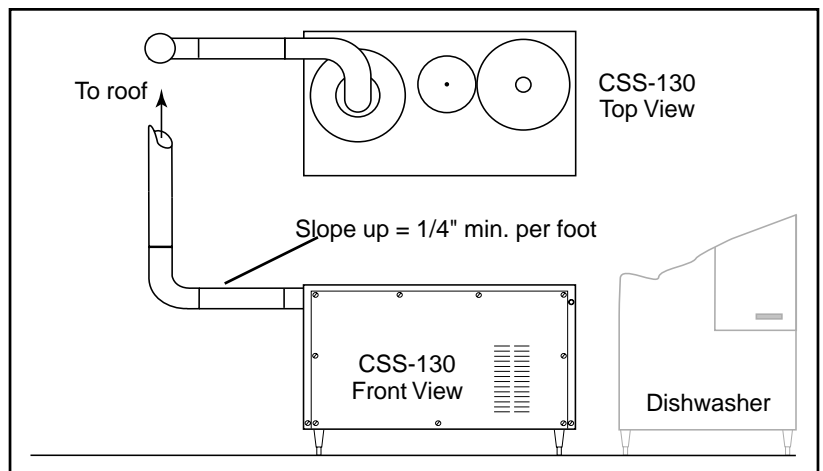

Figure 6
Vertical Through-the-Roof
Vent Installation with Fire Stops

Figure 7
CSS-130
Vertical Vent Configuration



Vent Installation (Cont'd)

Chimney Venting

The CSS-130 is certified as a Category I Boiler and approved for venting in a masonry chimney with Type B-1 Double-walled vent connector.

The following requirements must be met to use this type of vent installation:

1. The chimney must be internal lined or internal B vent type.
2. An external or unlined chimney may serve as a chase for the use of high temperature plastic pipe alternative venting provided that no other equipment is vented into the chimney. The chimney may have an approved liner installed into the flue.
3. Two (2) or more vent connectors, from either power or natural draft units, may enter a common gas vent provided that they conform to the provisions and tables of the National Fuel Gas Code, ANSI Z223.1/NFPA 54- Latest Edition, or applicable provisions of local building code. **For Canada**, the installation of this unit must conform to all Canadian local codes as applicable or, in the absence of local codes, to the Canadian installation code, CAN/CGA-B149.
4. None of the vent connectors may be connected to equipment with a positive vent pressure.
5. The unit must be located as close to the chimney as possible to provide the shortest vent connector.

Installation

Refer to Fig. 8 on page 11, and note the dimensions (H, L, D, and A).

These dimensions are taken in to consideration when determining the vent and vent connector requirements. Follow the procedure below to size the venting.

Determine the height of the chimney or Type B-1 vent and the length of the lateral run. Select the proper vent connector diameter from Table 11-2, Table 11-2a or Table 11-3 shown on pages 12-13. These tables were derived from Tables 11-2 and Table 11-3 of the National Fuel Gas Code, ANSI Z223.1/NFPA 54-Latest Edition.

Install and adaptor at the flue outlet of the boiler to step up to the diameter of the vent connector. Install elbows for the vent connector if required. All elbows should be the full size of the vent connector.



Caution:

Do Not install a three inch (3") elbow between the flue outlet on the boiler and the adaptor.

Install the vent connector between the elbows, if used, and the chimney. Slope the vent connector upwards toward the chimney 1/4" minimum per foot of lateral run.

Secure all joints in accordance with the vent manufacturer's instructions for Type B-1 vent material.

Chimney Venting

Figure X below shows the dimensions that must be taken into consideration when sizing the vent and the vent connector.

- H** = Height of the chimney or Type B vent
- L** = Total lateral length of the vent connector
- D** = Required diameter of vent connector (Refer to Tables on pages X-X).
- A** = Minimum/maximum size limits of internal area of the chimney

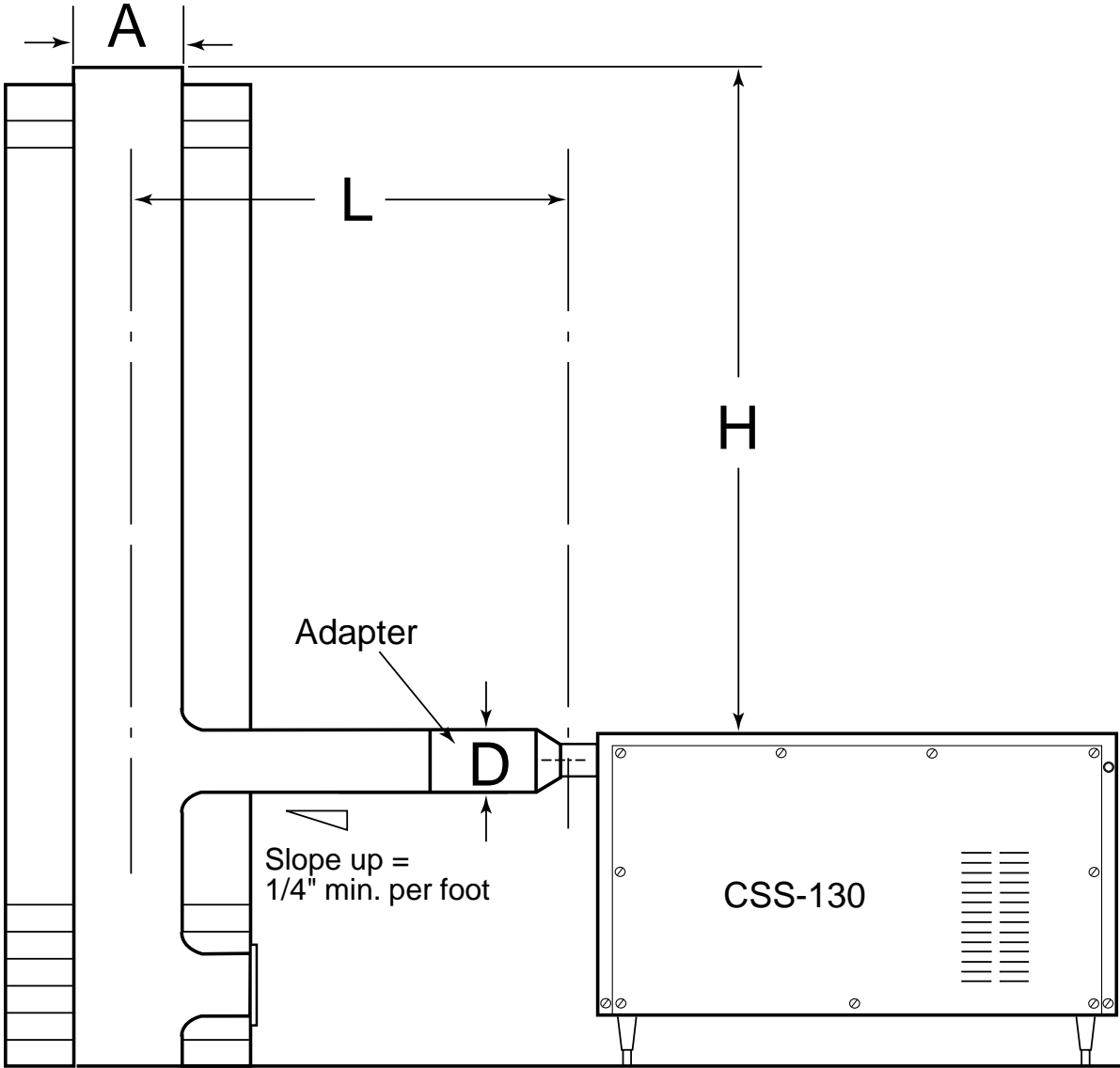

Figure 8
Type B-1 Vent Chimney Venting Detail
(Vent Connection without Elbows Shown)
(Lateral slopes up 1/4" min. per foot)

Refer to Vent Tables 11-2, 11-2a, and 11-3 on the next page for vent and vent connector diameter sizes.

Vent Installation (Cont'd)

Chimney Venting (Cont'd)

Refer to Table 11-2, 11-2a or 11-3 and select the vent and vent connector diameter that meets the requirements for your installation.

For example:

For Type B venting into a masonry chimney, refer to Table 11-3. If dimension (H) equals 30 feet, and the total (L) equals 10 feet, then the required vent diameter would be 8 inches (8") as denoted by the dot (●) in the 8" Diameter Pipe column of the Table.

Table 11-3			
Type B-1 Chimney Venting			
For CSS-130 Gas Fired Boiler Rated 130,000 BTU/HR			
Fan Assist			
Total Height (ft) (H)	Total Lateral (ft) Total (L)	7" Diameter Pipe (D)	8" Diameter Pipe (D)
10	2		●
15	2	●	●
	5		●
	10		●
20	2	●	●
	5	●	●
	10		●
30	2	●	●
	5	●	●
	10		●
50	2		●
	5		●
Type B-1 Double Connector Diameter to be used with chimney areas within the size limits at bottom			
Minimum Internal Area of Chimney (Square Inches) (A)		50	63
Maximum Internal Area of Chimney (Square Inches) (A)		269	352
Capacity of Masonry Chimney Flue with Type B-1 Double Wall Flue Connector Serving a Single Category I Appliance			

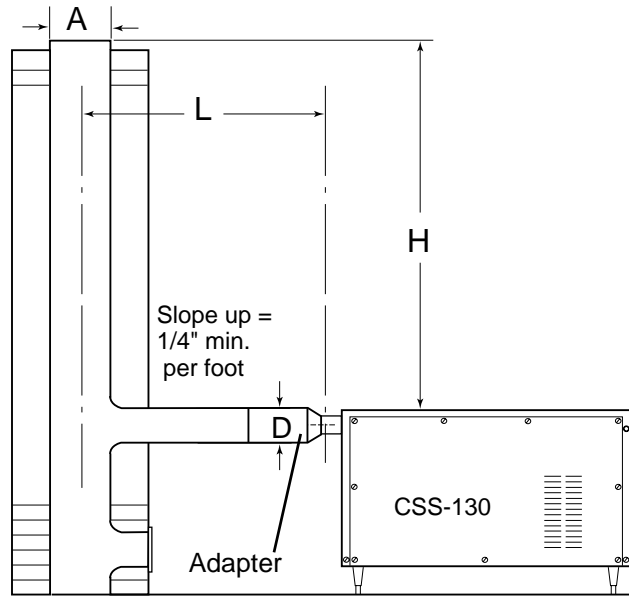

Figure 9
Type B-1 Chimney
Vent Connection without Elbows
(Lateral slopes up 1/4" min. per foot)

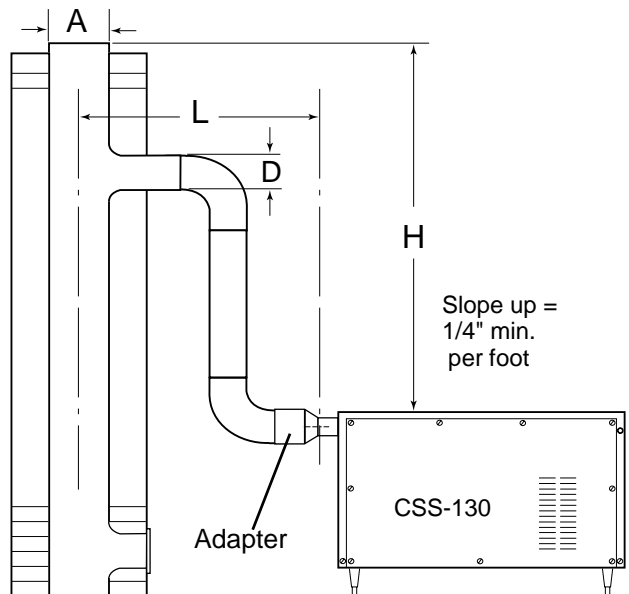

Figure 10
Type B-1 Chimney
Vent Connection with Elbows
(Laterals slope up 1/4" min. per foot)

Chimney Venting

Refer to Figs. 9-10 on the preceding page to determine the dimensions for your installation. Use the appropriate Table for your installation to determine the correct diameter of vent and vent connector.

H = Height of the chimney or Type B vent

L = Total lateral length of the vent connector

D = Required diameter of vent connector

A = Minimum/maximum size limits of internal area of the chimney

Table 11-2a Type B-1 Double-Wall Venting Derated for Sizing Flexible Metal Flueliners For CSS-130 Gas Fired Boiler Rated 130,000 BTU/HR				
Fan Assist Vent and Connector Diameter				
Total Height (ft) (H)	Total Lateral (ft) Total (L)	4" Diameter Pipe (D)	5" Diameter Pipe (D)	6" Diameter Pipe (D)
6	0		●	●
	2			●
	4			
	6			
8	0	●	●	●
	2		●	●
	5		●	
	8			
10	0	●	●	●
	2		●	●
	5		●	
15	0	●	●	●
	2		●	●
	5		●	
	10		●	
20	0	●	●	●
	2		●	●
	5		●	
	10		●	
30	0	●	●	●
	2	●	●	●
	5		●	
	10		●	
	15			

Table 11-2 Type B-1 Double-Wall Venting with Single Wall Metal Connectors Serving a Single Category I Appliance For CSS-130 Gas Fired Boiler Rated 130,000 BTU/HR				
Fan Assist Vent and Connector Diameter				
Total Height (ft) (H)	Total Lateral (ft) Total (L)	4" Diameter Pipe (D)	5" Diameter Pipe (D)	6" Diameter Pipe (D)
6	0	●	●	●
	2		●	●
	4			●
	6			
8	0	●	●	●
	2		●	●
	5		●	
	8		●	
10	0	●	●	●
	2		●	●
	5		●	
15	0	●	●	●
	2	●	●	●
	5		●	
	10		●	
20	0	●	●	●
	2	●	●	●
	5	●	●	
	10		●	
30	0	●	●	●
	2	●	●	●
	5	●	●	
	10	●	●	
	15	●		

INSTALLATION (CONT'D)

Vent Installation (Cont'd)

Horizontal Through-the-Wall Venting

The CSS-130 is approved as a Category III Boiler when a horizontal through-the-wall vent installation is used. This installation is a positive pressure venting system and requires that all connections be sealed with an approved high temperature sealant such as Dow Corning Silastic 736 RTV high temperature adhesive/sealant or UltraVent™ sealant from Hart and Cooley Inc.

The CSS-130 is certified for use with up to 50 equivalent feet of 3" diameter stainless steel pipe for horizontal vent installations. A 90° elbow equals 5 equivalent feet of pipe.



NOTE:

STAINLESS STEEL VENT PIPE MUST BE USED FOR HORIZONTAL RUNS.

Saf-T Vent® manufactured by Heat Fab, Inc., is constructed from AL294C stainless steel and is approved for use in the United States and Canada.

Vent installation must be in compliance with Part 7 "Venting of Equipment", of the National Fuel Gas Code; ANSI Z223.1-Latest Edition, local codes, or ordinances, these instructions, and good trade practices.

For Canada, the installation of this unit must conform to all Canadian local codes as applicable or, in the absence of local codes, to the Canadian installation code, CAN/CGA-B149.

Vent pipe and fittings must be securely supported. Horizontal runs must be supported at five foot intervals and at each point where an elbow is used.

To prevent condensate collection at any one point in the horizontal vent run, slope the vent pipe down 1/4" min. per foot of horizontal run (See Fig. 11 below).

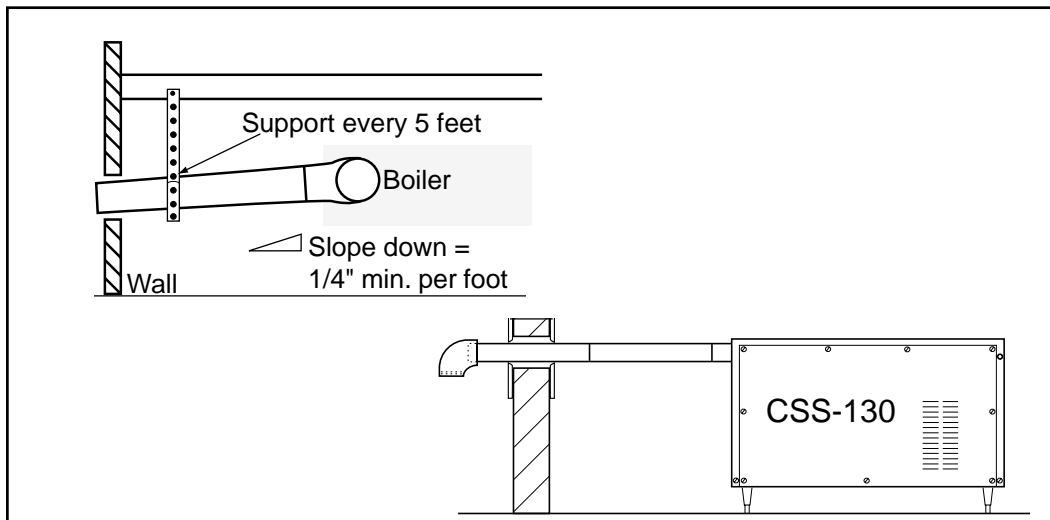

Figure 11
Horizontal Through-the-wall Venting
(Slope down 1/4" min. per foot)

Horizontal Through-the-Wall Venting (Cont'd)

Pipe Cutting and Joining Procedure

1. Using a sharp 24 teeth per inch hacksaw, hand cut pipe to length as square as possible.

**Caution:**

Do not use a power saw as it may cause damage to the pipe.

2. Clean pipe mating surfaces of all dirt, grease, and moisture.
3. Use Dow Corning Silastic 736 RTV high temperature adhesive/sealant, UltraVent™ sealant from Hart and Cooley, Inc., or other approved adhesive/sealant.

**Caution:**

Do not use solvent cements or other adhesives to join vent piping.

4. Insert one section of pipe into another. Use a felt marker or soft lead pencil to mark the pipe at the full insertion depth.
5. Separate the pipe sections and apply a generous bead of adhesive material around the end of the pipe within the marked area.
6. Using a twisting motion to spread the adhesive completely between the sections of pipe.
7. When the two sections of pipe have bottomed out, inspect the joint for a complete seal. Additional sealant may be required for a complete seal. It takes 24 hours of curing time to develop full joint strength.

**Caution:**

*Do not drill holes through pipe or fittings.
Do not use sheet metal screws or rivets.*

INSTALLATION (CONT'D)

Vent Installation

Horizontal Through-the-Wall Venting (Cont'd)

Locating the Vent Opening in the Outside Wall

It is essential to follow the National Fuel Gas Code, ANSI. Z223.1-Latest Edition and these instructions for proper venting and condensate disposal.

For Canada, the installation of this unit must conform to all Canadian local codes as applicable or, in the absence of local codes, to the Canadian installation code, CAN/CGA-B149.

1. The vent termination must be located at least 12" inches above grade or the normally expected snow accumulation level. (Snow level may be higher on walls exposed to prevailing winds.)
2. If adjacent to public walkways, the vent termination must be located 7 feet above grade.
3. Do not locate termination close to shrubbery.
4. The termination must be located at least 10 feet from any forced air inlet into the building and at least 4 feet horizontal and in no case above or below any other building opening, gas meter, electrical meter, service regulator, reliefs, or other equipment.
5. Do not locate termination near an alcove, over a window well, or closer than 5 feet to the corner of joining parts of the building structure.
6. Do not locate under any kind of deck or patio.
7. If possible, the wall through which the vent will pass should not be exposed to prevailing winds.
8. Select a point of wall penetration where the minimum 1/4" minimum per foot downward slope can be maintained.

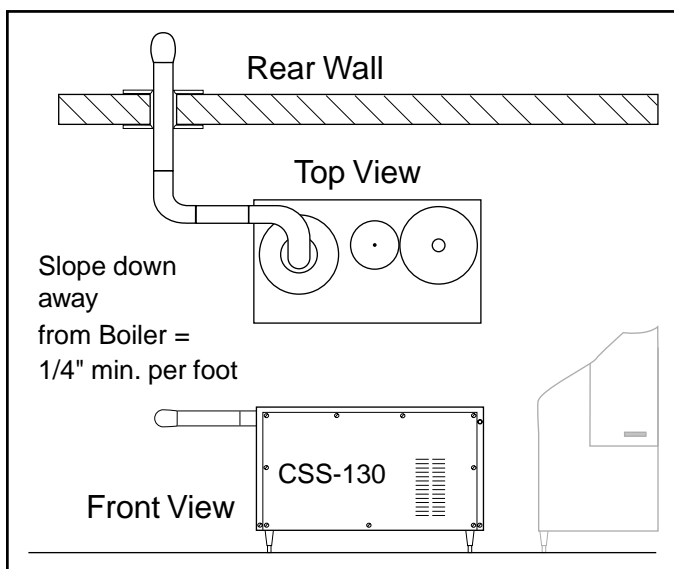

Figure 12
Horizontal Vent
(Exit Through Rear Wall)

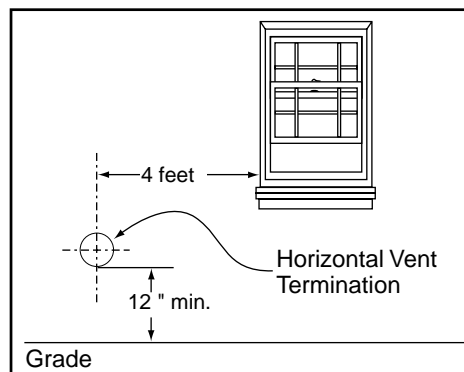

Figure 13
Horizontal Termination Clearance
(Window and Grade Level)

Horizontal Through-the-Wall Venting

Installing the Horizontal Venting and Termination

1. Cut a hole in a wall of the building at least 7" in diameter.
2. The hole must be located to maintain a downward slope of 1/4" minimum per foot of horizontal run from the boiler.
3. Install an approved thimble, one sleeve each to the inside and outside walls of the building.
4. Install the horizontal run from the boiler to the wall.
5. Install the last section of vent pipe so that it extends through both wall plates and terminates 1-1/4" beyond the outside wall thimble. (See Fig. X below)
6. Install a 3 inch (3") coupling to the end of the last section and seal with high temperature adhesive/sealant.
7. Seal all joints between the mounting plates and thimble with high temperature adhesive/sealant.
8. Install a 90° elbow to a 6-3/4" piece of 3 inch vent pipe.
9. Install a debris screen in the 90° elbow.
10. Install the assembly to the 3 inch coupling described in step 6 sealing all joints and making sure that the discharge end of the elbow is pointing straight down.
11. After installation, the distance between the outside wall thimble and the closest edge of the termination elbow must not be less than six inches. (See Fig. 14).

Figure 14
Horizontal Vent Termination

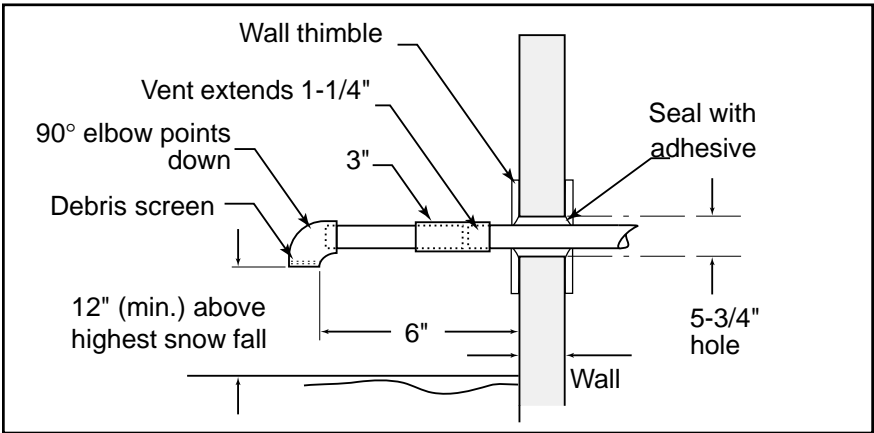
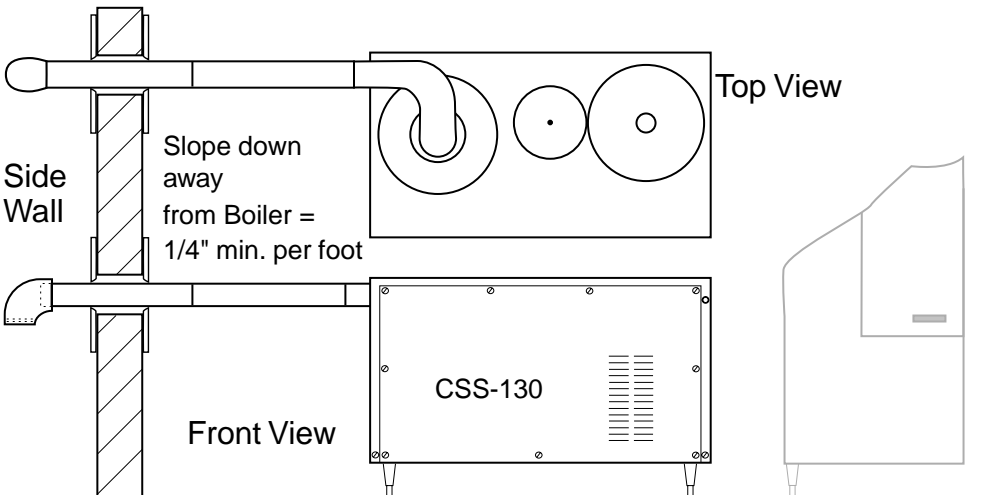

Figure 15
Horizontal Vent
(Exit Through Side Wall)



INSTALLATION (CONT'D)

Gas Supply Connections

≡ NOTE:

Gas connections must be in compliance with Part 3 "Gas Piping Installation", of the National Fuel Gas Code; ANSI Z223.1-Latest Edition, local codes, or ordinances, these instructions, and good trade practices.

For Canada, the installation of this unit must conform to all Canadian local codes as applicable or, in the absence of local codes, to the Canadian installation code, CAN/CGA-B149.

⚠ WARNING:

Gasoline, or other flammable materials and liquids (adhesives, solvents, etc.) and the vapors that they produce, are extremely dangerous. DO NOT handle, use or store gasoline or other flammable liquids anywhere near or in the vicinity of the gas boiler.

⚠ WARNING:

Inspect the vent system for proper installation BEFORE making gas supply connections.

Failure to install proper venting as described in the venting installation instructions of this manual (See pages 6-17) can result in unsafe operation of the CSS-130, gas fired boiler. To avoid the risk of fire, explosion, or asphyxiation from carbon monoxide, never operate the CSS-130, gas fired boiler unless it is properly vented and an adequate air supply for proper operation is available.

Gas Fuel Requirements

The CSS-130 is designed and certified for use with **Natural Gas** or **LP Gas**.

⚠ CAUTION:

Check the gas fuel specified on the CSS-130 rating plate before making any gas connection. The rating plate is located on the lower left side of the unit.

If the rating plate and the gas supply do not agree, refer to page 21, "Field Conversion of Gas Orifice".

Gas Pressure Requirements

1. Inlet gas supply pressure must be at least 4" W.C. and no greater than 14" W.C. for Natural and LP gas installations.
2. For **LP Gas Only**, the CSS-130 operates best with a supply pressure of 9-10" W.C. If no other appliances are being supplied by the LP gas supply, set the low pressure regulator to 9-10" W.C.
3. A maxitrol RV48 regulator or equivalent is recommended for regulating the inlet gas pressure.

Gas Supply Connections (Cont'd)

Gas Piping Installation

1. Supply piping must be sized correctly to minimize pressure drop between the meter or regulator and the CSS-130. Refer to Fig. 16 below for pipe capacity ratings and size the pipe for your installation to meet or exceed the 130,000 BTU/HR rating of the CSS-130.

2. **Run gas supply line in accordance with all applicable codes.**

3. **If the CSS-130 is installed above the gas supply, run piping up to a point above the vent center line and back down to the unit.**

This prevents water from entering the gas supply line should a water leak develop in the boiler section of the unit.

4. All threaded joints in the gas piping should be coated with piping compound. The compound must be resistant to the action of liquefied petroleum gases, (LP gas), even if your unit uses natural gas.

5. Pipe unions used in the gas line must be the ground-joint type.

6. Install a manual shut-off valve in accordance with state and local requirements if required. The CSS-130 is equipped with a manual shut-off valve.

7. A one-eighth inch (1/8") plugged tap, accessible for test gauge connection must be installed immediately upstream of the CSS-130 gas supply connection.

8. Install a trap and drip leg in the last vertical run before entering the CSS-130.

9. Support all piping with straps or hangers.

Length of Pipe (Straight Length)	Capacity of Pipe in MBTU/HR (.6 Specific Gravity of Gas)			
	1/2"	3/4"	1"	1-1/4"
10 ft.	132	278	520	1,050
20 ft.	92	190	350	730
30 ft.	73	152	285	590
40 ft.	63	130	245	500
50 ft.		115	215	440
75 ft.		93	175	360
100 ft.		79	150	305
150 ft.		64	120	250
Add equivalent ft. listed at right for each Tee or Bend →→→	1.3 ft.	1.7 ft.	2.2 ft.	2.7 ft.

Figure 16
Pipe Sizing Table
(Capacity of Pipe in MBTU/HR)
Based on .6 Specific Gravity of Gas

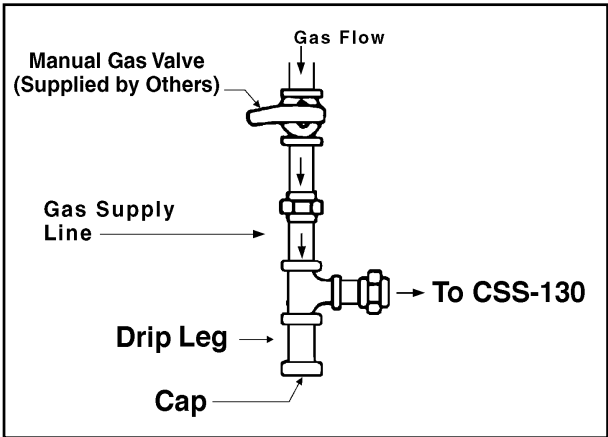

Figure 17
Gas Supply Piping
(Drip Leg)

INSTALLATION (CONT'D)

Gas Supply Connections

Gas Piping Installation (Cont'd)

Refer to Figs. 18, 19, and 20

9. Connect the gas supply piping to the CSS-130 at the lower left side of the unit.
10. Gas connection point is 1/2" NPT. (See A, Fig. 18)
11. The unit comes equipped with a 1/2" manual shut-off valve.
12. All threaded joints in the gas piping should be coated with piping compound. The compound must be resistant to the action of liquefied petroleum gases, (LP gas), even if your unit uses natural gas.

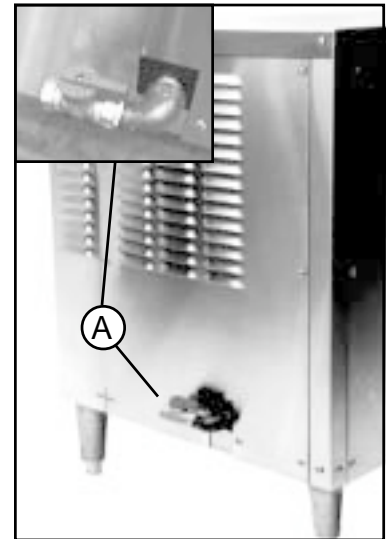

Figure 18
CSS-130
Manual Gas Shut-off Valve

Pressure Testing the Gas Piping Installation

1. The CSS-130 and its manual gas shut-off valve must be disconnected from the gas supply piping system during any pressure testing of the system at test pressures in excess of 1/2 psig.
2. The CSS-130 must be isolated from the gas supply piping system by closing its individual manual gas shut-off valve during any pressure testing of the gas supply system at test pressures equal to or less than 1/2 psig.

Figure 19
Gas Connection Point
(Side View)

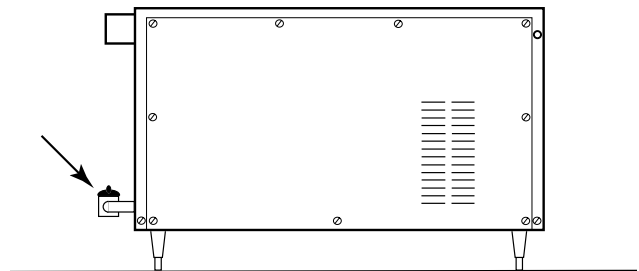
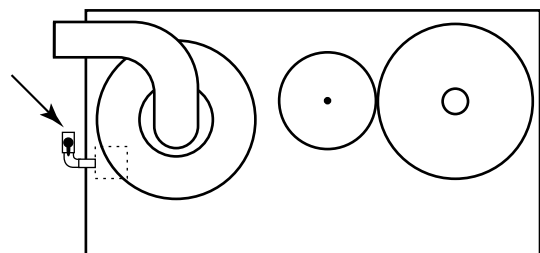

Figure 20
Gas Connection Point
(Top View)



Gas Supply Connections

Field Conversion of Gas Orifice

The CSS-130 requires a gas orifice specifically designed for either Natural or LP gas. If the gas fuel supply at the installation site does not match the gas type marked on the machine data plate located on the front panel of the gas fired boiler, you will have to change the gas orifice.

! WARNING:
When working on any electrical circuit, disconnect the power at the main service disconnect switch or breaker and place a tag at the disconnect switch to indicate that work is being performed on the circuit.

! WARNING:
Close the CSS-130 manual gas shut-off valve located on the left side of the unit before you remove the gas orifice union.

Refer to Figs. 21, 22, and 23

1. The gas orifice union is located behind the gas burner recirculation pump near the center of the CSS-130.
2. The gas orifice is screwed into the union.
(See Fig. 22, Orifice Detail)
3. To convert the gas orifice, remove the orifice union and unscrew the gas orifice.
4. Install the correct orifice for your gas supply.
5. An LP gas conversion kit, P/N [111993](#), is available from Champion. This kit contains a label marked "Propane Gas". Be sure to apply this sticker to the data plate on the front panel of the CSS-130 adjacent to the data plate.
4. Reassemble the gas union. All threaded joints in the gas piping should be coated with piping compound.
5. Turn the gas supply on. Test for gas leaks. Check the CSS-130 for proper operation.

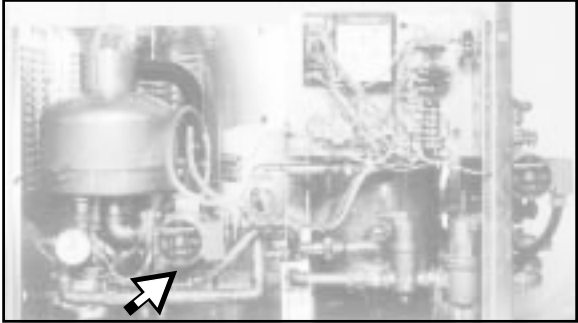

Figure 21
Gas Orifice Union Location

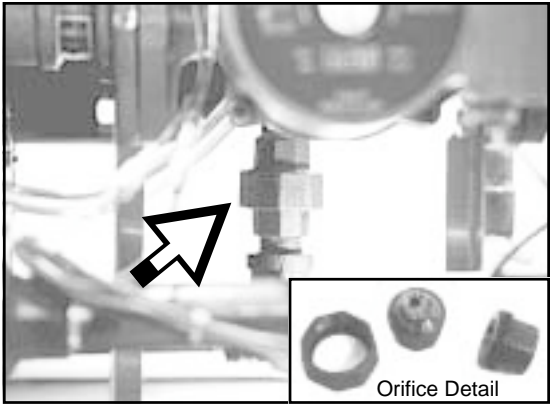

Figure 22
Gas Orifice Union



Figure 23
LP Gas Orifice Kit
P/N [111993](#)

INSTALLATION (CONT'D)

Electrical Connections

Refer to Figs. 24-26.

1. The CSS-130 requires a single (120 v, 60 Hz, 15 amp) electrical power source.
2. Electrical fittings with conduit run through the interior of the boiler is provided to connect the incoming power supply. Conduit to interconnect the CSS-130 to the dishwasher is provided.
3. All electrical connections are made in the CSS-130 control cabinet which is located on the right side front of the unit (See Fig. 25).
Wiring connections should be made as shown in the electrical schematic (See Fig. 26).
4. Control wiring for an optional dishwasher ventilation fan contactor or starter may be run through the same conduit into the terminal strip located in the boiler control cabinet. *(Optional fans must be approved by local authority.)*
5. A fused disconnect switch or circuit breaker (supplied by others) is required to protect the power supply circuit.



NOTE:

All electrical and grounding connections must be made in accordance with the requirements of the authority having jurisdiction or, in the absence of such requirements, with the National Electrical Code, ANSI/NFPA 70. Installation should also conform with CSA C22.1 Canadian Electrical Code Part I.



WARNING:

When working on any electrical circuit, disconnect the power at the main service disconnect switch or breaker and place a tag at the disconnect switch to indicate that work is being performed on the circuit.

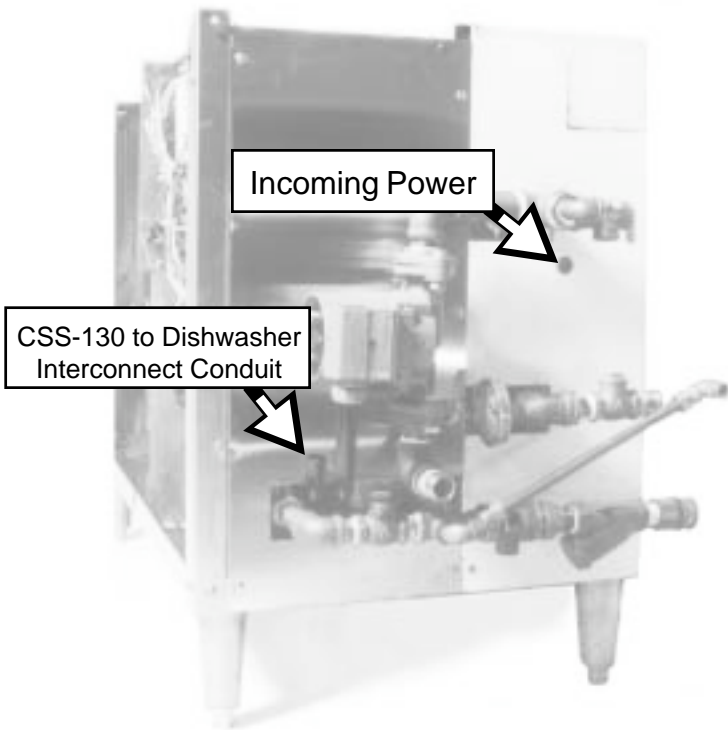

Figure 24
Electrical Connections
(Right side of CSS-130)

Electrical Connections (Cont'd)

- 6. The schematic detail, Fig. 25 shows the incoming power connected at the power contactor. The contactor is located inside the CSS-130 control cabinet.
- 7. The incoming power must be connected to the power contactor as shown. Any other connection point will prevent the CSS-130 from operating properly.
- 8. The complete wiring schematic for the CSS-130 can be found on page 44.

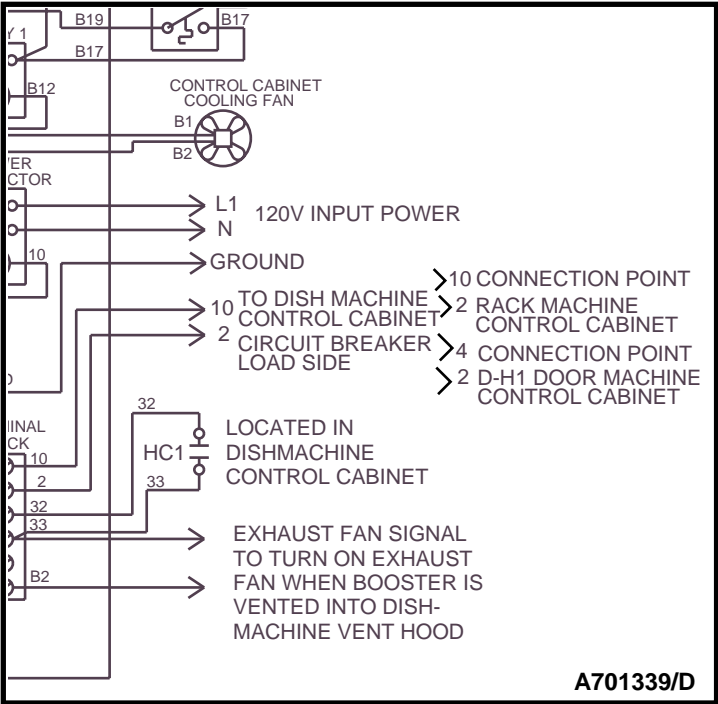

Figure 25
Electrical Schematic Detail

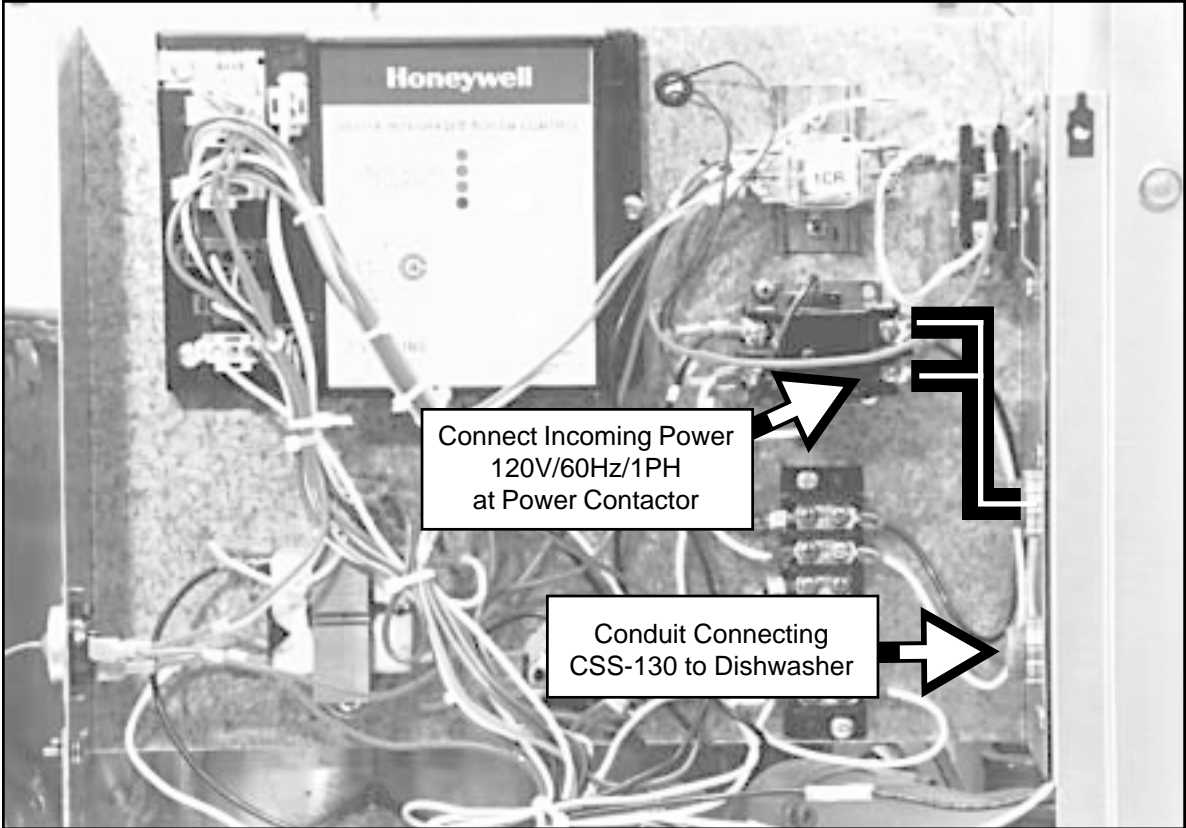

Figure 26
CSS-130 Control Panel Power Connections
(Inside right front side)

INSTALLATION (CONT'D)

Plumbing Connections



WARNING:

Plumbing connections must comply with local sanitary and plumbing codes.

Water and Drain Connections

Refer to Fig. 27.

1. The CSS-130 requires a single 3/4" NPT hot water connection.
 - Minimum incoming water supply temperature should be 140°F/60°C.
 - Minimum and maximum incoming water supply pressure should be 23 PSI/159 kPa.
2. The CSS-130 is equipped with a 3/4" pressure reducing valve, PRV on the incoming water supply line.
3. The CSS-130 is equipped with a pressure relief valve, (30 PSI/207 Kpa, 130 lbs/hr minimum capacity) on the CSS-130 water outlet.



CAUTION:

The boiler pressure relief valve and back-flow preventer should be piped separately to a floor drain to remove any water discharge from the gas-fired boiler.

4. The CSS-130 is equipped with the piping required to interconnect it to the dishwasher.

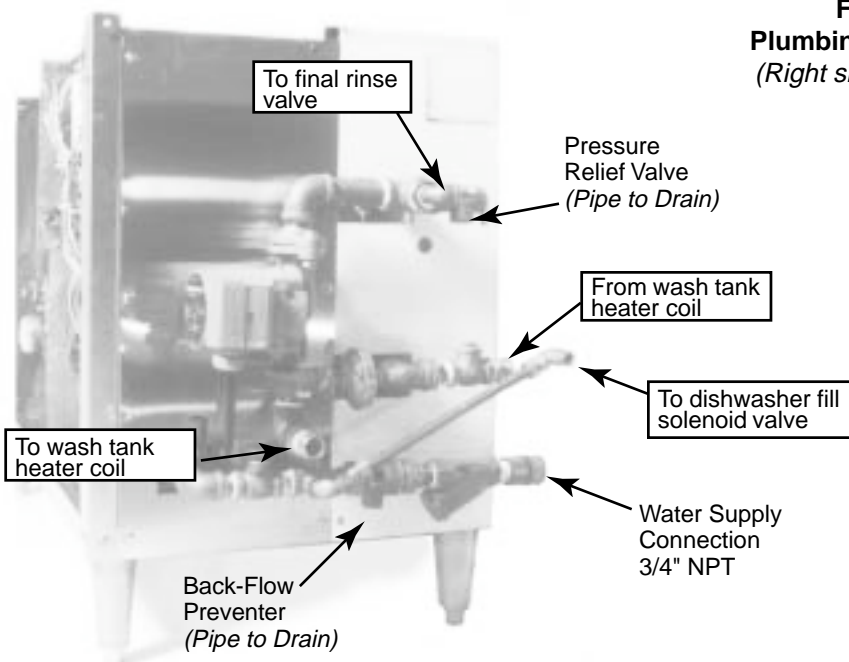

Figure 27
Plumbing Connections
(Right side of CSS-130)

INITIAL START-UP AND SERVICE

ATTENTION INSTALLER

INSTRUCTIONS FOR SETTING AIR PRESSURE IN EXPANSION TANK

NOTE:

Expansion tank air pressure should be set to 20 PSI for proper operation.

Note:

The best time to check the air pressure in the expansion tank is sometime before the water and electric service are connected to the boiler.

For boiler assembly **BEFORE** it is filled with water

1. Make sure Dishwasher's main power switch is OFF.
2. Make sure main water supply valve is OFF.
3. Check the expansion tank pressure with an air gauge.
4. Depress valve stem to allow air to escape.
5. Check pressure and repeat the above until the tank pressure reading is 20 PSI.
6. If too much air is released, use a tire chuck and add air until the pressure gauge reads 20 PSI.
7. Acceptable pressure range is 19-20 PSI.

For boiler assembly **AFTER** it is filled with water

1. Make sure Dishwasher's main power switch is OFF.
2. Make sure main water supply valve is OFF.
3. Slightly open drain valve located at the bottom of the storage tank to bleed off some water until the dishwasher Final Rinse Gauge reads 0 PSI.
4. Close the storage tank drain valve.
5. Check the expansion tank pressure with an air gauge.
6. Check pressure and repeat the above until the tank pressure reading is 20 PSI.
7. If too much air is released, use a tire chuck and add air until the pressure gauge reads 20 PSI.
8. Acceptable pressure range is 19-20 PSI.
9. Open water supply valve.

ATTENTION INSTALLER

INSTRUCTIONS FOR MANUALLY VENTING AIR FROM BOILER WATER SYSTEM

CAUTION:

Failure to follow instructions will result in permanent damage to the recirculating pumps.

NOTE: Plumbing and Electrical service connections must be completed BEFORE performing the following procedures.

1. Make sure Dishwasher's main power switch is OFF.
2. Make sure main water supply valve is OFF.
3. Check high vent knurled cap on boiler holding tank.
— If closed, turn knurled cap (A) CCW one complete turn.
4. Open petcock (B) on outlet side of dishwasher tank heater coil piping.
5. Remove silver air bleed plug (C) in center of recirculating pump. Pump is located on right front corner.
6. Remove silver air bleed plug (D) in center of burner recirculating pump.
7. Open air bleed petcock (E) on lower left front of burner assy.
8. Turn main water supply ON
— Water fills the gas boiler and dishwasher tank heater coil.
— Air or a mixture of air and water, then water only should be observed coming from petcock/vents.
9. Observe air bleed petcock (E).
— Make sure a steady stream of water comes from petcock (E) then close the petcock.
10. When boiler holding tank is full, turn dishwasher main power switch ON.
— Dishwasher fills automatically.
— Boiler may begin ignition cycle.
— One or both boiler recirculating pumps run.
11. Observe vent ports. Make sure a steady stream of water comes from all ports.
12. Close petcock and reinstall recirculating pump plugs in the following order.
— Install the plug (D) on burner recirculating pump.
— Install the plug (C) on return recirculating pump.
— Close dishmachine's petcock (B) located on outlet side of wash tank heater coil.
13. Check the amp draw on the boiler recirculating pumps. The correct reading should be between 1.2A to 1.7A.
14. If reading is less than 1.2A, repeat Steps 3-12 and recheck recirculating pump amps.

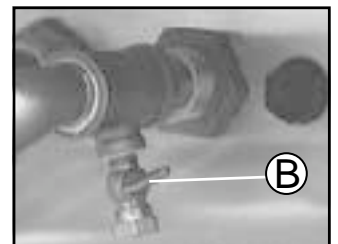
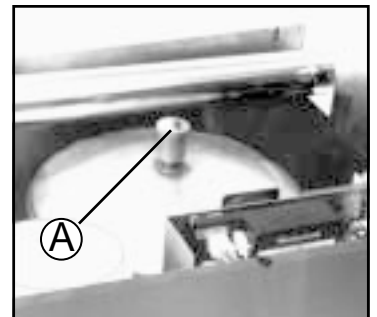
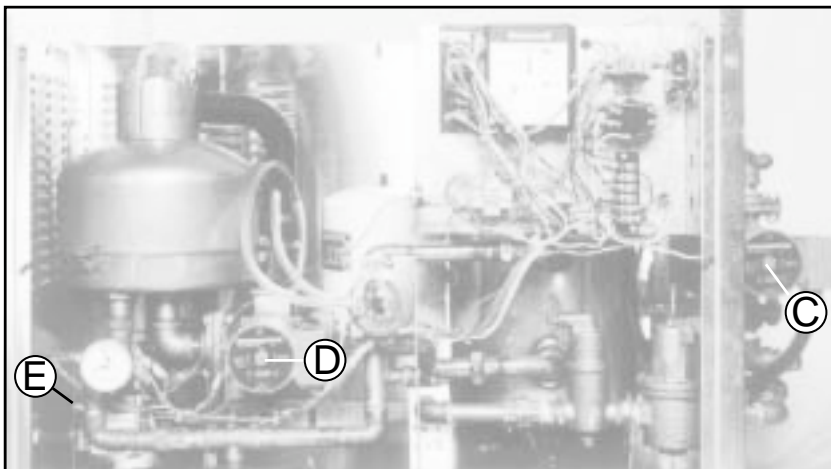

FOR YOUR SAFETY READ BEFORE OPERATING

WARNING: If you not follow these instructions exactly, a fire or explosion may result causing property damage, personal injury or loss of life.

- A. This appliance does not have a pilot. It is equipped with an ignition device which automatically lights the burner. **DO NOT** try to light the burner by hand.
- B. **BEFORE OPERATING** smell all around the appliance area for gas. Be sure to smell next to the floor because some gas is heavier than air and will settle on the floor.
- WHAT TO DO IF YOU SMELL GAS**
- * Do not try to light any appliance.
 - * Do not touch any electric switch; do not use any phone in your building.
 - * Immediately call your gas supplier from a neighbor's phone. Follow the gas supplier's instructions.
- * If you cannot reach your gas supplier, call the fire department.
- C. Use only your hand to push or turn the gas control knob. Never use tools. If the knob will not push in or turn by hand, do not try to repair it, call qualified service technician. Force or attempted repair may result in a fire or explosion.
- D. Do not use this appliance if any part has been under water. Immediately call qualified service technician to inspect the appliance and to replace any part of the control system and any gas control which has been under water.

OPERATING INSTRUCTIONS

1. **STOP!** Read the safety information above on this label.
2. Make sure system has been properly filled with water and bled of air.
3. Turn off all electric power to the appliance.
4. This appliance is equipped with an ignition device which automatically lights the burner. Do not try to light the burner by hand.
5. Turn manual gas valve located on left side of unit to "ON" position.
6. Push in gas control knob slightly and turn clockwise ↻ to "OFF". Do not force.
7. Wait five (5) minutes to clear out any gas. Then smell for gas, including near the floor. If you smell gas, **STOP!** Follow "B" in the safety information above on this label. If you do not smell gas, go to the next step.
8. Turn the gas control knob counter clockwise ↻ to "ON".
9. Close the access door on the left side cover panel.
10. Turn on all electric power to the appliance.
11. If the appliance will not operate, follow the instructions to "Turn Off Gas Appliance" and call your service technician or gas supplier.

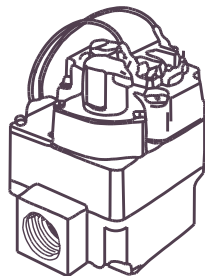

TO TURN OFF GAS TO APPLIANCE

1. Turn off all electric power to the appliance if service is to be performed.
2. Turn manual gas valve located on left side of unit to "OFF" position.
3. Push in gas control knob slightly and turn clockwise ↻ to "OFF". Do Not Force.

CHECK, TEST & START- UP

FILLING SYSTEM

1. Open all supply and return valves.
2. Fill heating system to minimum operating pressure -20 psig.
3. Open bleed pet cock and bleed air from heater coil until a good dream of water comes out.
4. Purge all lines by opening vents, or with flushing valves.
5. Close gas valve.
6. Turn on 120 volt power, and listen for unit circulator to start. Unit will cycle off on lockout.
7. Open all vents again to discharge any additional air and close off after air is eliminated.
8. System is now ready for operation.

INITIAL FIRING

1. Be sure that system has been filled properly (see above) and does not leak.
2. Open gas cock(s). Open manual gas shut-off valve by turning to "on" position.
3. Turn on main dishwasher power switch, and set thermostat to call for heat. In approximately 2 seconds, blower will come on.

NOTE: Burner may not ignite on first attempt because of air in gas lines. In this case, blower will stop after 5 minutes. Should this happen, turn off main switch. Wait 5 minutes and turn on main switch again.

4. If burner fails to ignite after three attempts, refer to Troubleshooting Section 2, Service Manual or call service for troubleshooting.

WARNING: Should any pronounced odor of gas be detected, or if the gas burner does not appear to be functioning in a normal manner, close main shut-off valve, do NOT shut off switch, and contact your heating contractor, gas company, or factory representative.

5. You MUST check flame monitoring control (ignition system safety shut-off device).
 - a. Close gas cock with burner operating.
 - b. In 3 seconds, FLAME indicator light will go out and blower will continue to run on post purge cycle. Two additional attempts to light will follow including pre-purge, igniter on, valve/flame on and post purge. (Ignition will not occur-gas off).
 - c. Open gas cock. Switch dishwasher power switch "OFF" and then "ON" again. Burner should start after about 45 secs. It is recommended that the unit be checked with a standard CO₂ or O₂ tester. Insert tester probe at least 6" into exhaust pipe through outside vent terminal. Readings should be:

CO₂- 8% to 8.5% (nat. gas) 9% to 9.8% (LP gas)

O₂- 7% to 6%

6. Check burner input (other equipment off)
 - a. Measure the time, in seconds, it takes to use one cubic foot of gas.
 - b. Divide the number of seconds into 3,600.
 - c. Multiply the result by the heating value of the gas to obtain BTU/HR input.

Example: If it takes 36 seconds to use one cubic foot of gas and the heating value of the gas is 1,000 BTU/CU FT, (approximate natural gas value).

$$\text{INPUT} = 3,600/36 \times 1,000 = 100,000 \text{ BTU/HR}$$

Input Ranges

127,400 BTU/HR to 132,600 BTU/HR

Because of the altitude and other minor variations, it is possible the input will not fall within this range and the gas orifice must be replaced. See chart in an orifice kit.

LIGHTING AND SHUTDOWN INSTRUCTIONS

A. LIGHTING

1. Ensure that heater is filled with water, air is bled from boiler coil and water pressure is at a minimum of 12 psi.
2. Open **manual gas valve**.
3. Open gas cock on gas valve.
4. Turn "ON" dishwasher power.
5. After 45 seconds, ignition will occur (if there is a call for heat).

B. SHUTDOWN

1. Turn "OFF" disconnect switch to boiler and dishwasher.
2. **Close manual gas valve.**
3. **Close gas cock on gas valve.**

MAINTENANCE

OWNER CARE AND MAINTENANCE

1. Inspect venting system - Annually remove screws on vent terminal and remove terminal. Inspect interior with flash light. **Reassemble and reseal exhaust vent air system.**
2. General Housekeeping - Keep **boiler** area clear and free from combustible materials, gasoline and other flammable vapors and liquids. Keep **boiler cabinet** louvers clear for proper cooling of internal components. Do not obstruct **boiler** room ventilation screens or grills.

SERVICE MAINTENANCE

Cleaning heat exchanger to be done by qualified service person.

CAUTION: Label all wires prior to disconnection when servicing controls. Wiring errors can cause improper and dangerous operation.

Verify proper operation after servicing.

**This Page
Intentionally
Left Blank**

ADJUSTING BURNER / INPUT

The CSS-130 burner system is a pre-mixed, forced combustion system. Outside air is drawn through the air orifice (located in the air induction system) and mixed with the gas drawn in downstream of the air orifice. The gas is metered through an orifice located in the gas orifice union. All the air required for complete combustion comes into the unit in this manner.

Adjusting the input is limited to changing the gas orifice to achieve the proper input. The air orifice cannot be altered and the gas valve pressure setting cannot be changed.

Before changing the gas orifice to correct input, service representatives should make the following checks:

1. The pressure on the inlet side of the gas valve is between 4" and 14" water column.
2. The pressure on the outlet side (manifold) of the gas valve and "T" above air orifice is between -0.05" and -0.35" water column with the unit operating.

To increase the input, install larger diameter gas orifice. Each size will change the input approximately 5 C. F. H. Once the correct input has been achieved, the burner should be checked with an oxygen (O₂) or carbon dioxide (CO₂) gas analyzer.

The unit should be in operation 5 minutes before adjusting input or taking CO₂ or O₂ readings. This time will allow for preheating of the intake air.

Insert the probe of the O₂ or CO₂ tester at least 6" into the vent through the vent terminal. If CO₂ is being measured, the readings should be between 8.0 and 8.5 for natural gas and 9.0 and 9.8% for propane. If O₂ is being measured, the readings should be between 7 and 6.

Measuring CO₂*

When operating on natural gas, readings below 8.0 generally indicate a lean mixture (not enough gas). Readings above 9.25 generally indicate a rich mixture (too much gas). Inputs should be increased or decreased to correct lean or rich mixtures.

NOTE: If the mixture is very rich (not enough air for complete combustion), it is possible to get low readings on a CO₂ analyzer. This situation does not occur often but it can be detected if reading continues to go lower as the input is increased. If this condition is suspected, a CO test should be taken at the vent outlet. Inputs must be reduced to correct high CO reading and to bring CO₂ readings to proper levels.

*The following numbers apply to natural gas only. The range of operation for LP is 9.0 to 9.8 % CO₂.

Measuring O₂

Readings above 7% indicate a lean mixture (not enough gas). Readings below 6% indicate a rich mixture. Input should be increased or decreased to correct lean or rich mixtures.

CLEANING COMBUSTION CHAMBER COIL

1. Turn off electric and gas supplies and remove the jacket
2. Remove the vent assembly and top cover.
3. Remove the top half of the combustion chamber by removing the 3 screws and nuts that clamp the top half to the bottom half. Remove the clamp on the air orifice hose and the two clear plastic lines connected to the "T" on the air induction elbow.
4. Remove the top insulator cap by spreading the retainer.
5. Remove the igniter.
6. Clean the finned tubing with a wire brush and vacuum all loose material from the combustion chamber.
7. Replace all parts in the reverse order in which they were removed.
8. Restart the unit as indicated by the lighting instruction label.

UNIT PUMP

The unit pump operates whenever there is a call for heat or hot water.

It is a wetted-rotor type pump and should always be filled with water when it is operating so that it will cool properly.

If a pump change is required for any reason, close gas valve and drain water from the unit. Turn off the main disconnect switch and unplug the pump wires, remove the pump motor.

The pump housing need not be removed. The replacement pump motor should be installed in the reverse order from which the old pump motor was removed. After filling the system be sure to bleed the coil at coil bleed petcock.

NOTE: If the pump motor is not defective the pump cartridge alone may be changed.

GAS VALVE

The gas valve is a solenoid operated, negative pressure regulated valve. The outlet pressure is regulated at -0.2" w.c. It is designed to operate with supply pressures of 4-14" w.c. Within that range of supply pressures, the regulated discharge pressure may vary from -0.05" to -0.35" inches w.c. The regulator is not adjustable and the effect of this variation in discharge pressure is not significant. Because of the fixed regulator setting, gas flow must be adjusted by changing the gas orifice.

To remove the gas valve, shut off 120 volt power and the master gas cock in gas line, loosen the nut on the gas orifice union and remove the orifice union plus piping to the gas valve. Disconnect the wires from the gas valve. The valve may now be unscrewed from the inlet piping. After the valve has been removed, replace with a new valve in the reverse order in which the old valve was removed. Do not over tighten the fittings into the valve body as this may cause damage to the valve.

NOTE: When fueled by LP gas, the CSS-130 performs best with 9-10" w.c. supply pressure. If no other appliances are being supplied by the LP supply set the low pressure regulator to 9-10" w.c.

SAFETY LIMIT SWITCH

The Safety Limit Switch has a fixed set point at 240°F. It will reset automatically.

To replace the switch, shut off the 120 volt power and close gas valve, drain water from the heater and remove the nut which holds the safety limit bulb in the heater discharge fitting. Remove the bulb from the fitting and remove the 2 screws which hold the switch assembly to the electrical control box. Disconnect the 2 wires from the quick connects at switch and remove the safety limit assembly. To replace, perform the same operations in reverse. Push the sensing bulb as far into the fitting as possible before tightening sealing nut. No more than 1/2" of sensing bulb should be visible after installation. Fill the heater and be sure to bleed the coil at the coil bleed petcock. Turn on disconnect switch and check heater operation.

OPERATING CONTROL

The Operating Control maintains boiler discharge temperature between 180-199°F. It has a fixed set point of 210°F at the output of the burner and a differential of 30°F. If replacement is necessary, shut off the 120 volt power and disconnect the wires to the sensor. Valve off and drain water from the unit and remove sensor. Install new sensor, refill heater and bleed coil at coil bleed petcock. Check boiler operation after installation of new Operating Control. Its contacts open at 210°F and they reclose at 180°F.

IGNITER

The igniter is a "glow bar" type silicon carbide unit. It is energized whenever there is a call for heat and the red "IGNITER" light on the heater control is lit. After the igniter is switched off and the heater continues to run, the igniter functions as a flame sensor for the heater control.

If the igniter fails and must be replaced, always install a new igniter gasket with the replacement igniter.

CAUTION: Ignitor gets hot.

PRESSURE SWITCH

The Differential Pressure Switch is a normally open single pole switch which is designed to detect pump operation, water flow and operate as a low water cut off device. To replace, turn off electrical power & boiler feed water. Valve off and drain water from the heater, unplug wires from the switch and remove switch. Install new switch in reverse order. Refill heater and bleed air from the coil bleed petcock. Turn on electrical power and recycle system

TRANSFORMER

The control transformer accepts 120 VAC power and provides 40 VA of 24 VAC power for the heater control only.

BLOWER

The Combustion Air Blower is a high head centrifugal blower. It is designed to provide about 2" w.c. of suction at 30 CFM. This performance is necessary to operate the gas valve reliably, to overcome induction system friction losses and to eliminate any sensitivity to wind striking the vent terminal. It is powered by a 120 volt motor which draws about 1.3 amps at rated load. It is powered by the integrated heater control whenever there is a call for heat and 30 seconds thereafter. If a blower change is required, turn off the 120 volt power and unplug the power wires from the blower motor. Remove the three nuts from the blower discharge flange and the four nuts from the blower inlet flange. The blower may now be deflected enough to permit its removal. Install the new blower using new gaskets, in the reverse order from which the old blower was removed. The four inlet flange nuts, however, should only be finger tight initially and then tighten with a wrench after all other operations have been completed. The combustion should be checked for correct air-fuel ratio whenever the blower is replaced (see Burner Adjustment).

HEATER CONTROL

The Integrated Heater Control Module controls the combustion process, the gas valve, the igniter, the blower, the unit pump and the system circulator. It provides blower pre-purge as well as burner flame sensing. When replacing the heater control turn off disconnect switch and press in tabs on each end of plugs to remove from control. All plugs are color coded and it is not possible to miswire the control.

STACK SWITCH

The Stack Switch is a normally open single pole switch which is operated by the pressure difference across the air orifice. It is set to close when a static pressure difference of 1" w.c. is generated by the combustion air blower. Its function is to prove airflow and to inhibit burner operation in the event of flue or chimney stoppage. The switch is wired directly to the heater control. It is located behind the front panel, and is attached to the left-hand control cabinet support bracket.

STORAGE TANK

The Storage Tank contains approximately 10 gallons of heater water. It functions as an energy storage vessel to reduce heater cycling.

TIME DELAY RELAY (TDR)

The Time Delay Relay controls the unit pump and keeps it operating for approximately one minute after the blower post purge stops. Control voltage on the TDR is 24 volts from the limit circuit. The contacts to supply pump power are 120 VAC. They delay on open one minute after the 24 volt control voltage is interrupted. Turn off disconnect switch before changing TDR.

DELAYED IGNITION

Possible Causes - Time of occurrence

- a. High lockups on LP - occurs on start-up.
 - b. Gas valve regulation problem - occurs on start-up.
 - c. Defective burner (flameholder) - occurs primarily on burner shutdown
 - d. Natural gas orifice in LP unit- occurs on startup
- a). High lock up pressures on LP fuel systems are the most common cause of delayed ignitions on CSS-130 heaters. The high LP supply pressure results from improper second stage regulator selection or a faulty regulator.

It can be detected by measuring the gas supply pressure to the unit at the inlet pressure tap on the gas valve. Use a water manometer or pressure gauge with a scale reading of at least 25" w.c. Install the pressure tap in the 1/8" NPTF plugged port located above the gas inlet port on the gas valve. The gas supply to the heater must be shut off before making this connection. The CSS-130 heater is designed to operate with supply pressures of 4-14" w.c. If supply pressure exceeds 14" w.c. with the heater not operating it is likely that this is the cause of the delayed ignition. Lock up pressures must be measured when the heater is not operating and preferably immediately after heater shutdown

b). Gas valve regulation problems can also cause delayed ignitions. To detect gas valve regulation problems it is necessary to have an inclined manometer or a Magnehelic pressure gauge. The normal gas valve regulator setting is -0.2" w.c. It is measured between the 1/8" NPTF plugged port marked PRESS TAP on the gas valve and the barbed fitting above the air orifice coupling.

The pressure will be about -2.5" w.c. when the blower is running (prepurge) before the gas valve opens. When the gas valve is energized and the solenoid opens the pressure should rise to - 0.2" w.c. This should happen smoothly without allowing the pressure to go positive (above 0" w.c.). If the pressure spikes positive when the solenoid opens then the gas valve regulator is faulty and may be the cause of the delayed ignition (assuming inlet tested OK).

c). A defective burner (flameholder) can cause a delayed ignition however not often. If the gas supply pressure and the gas valve are functioning properly and the air and gas orifices are correct the burner should be inspected. To inspect, remove the blower and the burner will drop out of the bottom of the chamber. There should be no perforations other than the punched holes. When replacing the burner the insulating pad must be on the top of it. If none was on the burner when it was removed check to see if it fell off during burner removal and has stayed in the combustion chamber. Never leave an insulating pad lying in the combustion chamber as this can cause burner overheating and perforation.

NOISY OPERATION

There are two principal sources of noisy operation:

- a. Combustion - high pitched noise - whistle or hoot
- b. Boiling (kettling) - lower frequency noise which varies with temperature - moan.

a). Combustion noise occurs at any boiler discharge temperature and is heard the loudest at the flue outlet (especially on units with side wall venting). There are two basic causes for the noise, rich mixture and cross contamination. To check for a rich mixture, it will be necessary to measure the percent O₂ or CO₂ in the flue products. O₂ readings lower than 4-1/2% or CO₂ readings higher than 9-1/4% (natural gas) and 10.8% (LP) will often cause combustion noise. To eliminate the noise it will be necessary to install a smaller gas orifice so that the O₂ will rise above 4-1/2% or the CO₂ will drop to 9-1/4% (natural) or 10.8% (LP).

Sometimes the readings are influenced by cross contamination and a check for cross contamination should be done before changing orifices if it is suspected. A strong smell from the flue products is generally an indication. Check for cross contamination using the procedure listed in the index. If there is no cross contamination, reorificing should be done.

b). Boiling (kettling) may occur at heater discharge temperatures from 170°F to 210°F. The temperature at which it starts will vary from one installation to another. The primary cause of the problem is poor heat transfer on the inside of the heater coil. This may be caused by scaling from the heater water if no antifreeze is present.

Many times it is difficult to determine if the noise is combustion or boiling related. The best clue is when in the cycle the noise appears and if its frequency changes with heater discharge temperature. Combustion noises always have the same frequency, however, their volume may change from the time that the burner first fires to the time that it shuts off. Boiling noises have a frequency that varies with boiler discharge temperature and sometimes they will disappear completely at higher temperatures just before the heater goes off on limit. Vibration of the heater pressure gauge needle may also occur with boiling noises.

INSUFFICIENT HOT WATER

Possible Cause:

- a. Low limit failure
 - b. Coil contamination
- a). Failure of the low limit to operate within its normal calibration points will have the same effect as incorrect system circulator wiring.
- b). Coil scaling may occur in some areas of the country where there are high concentrations of minerals in the water. These minerals may cause fouling of the domestic hot water coil over an extended period of time (lime build up) or they may in rare instances cause a problem in less than a year of operation. The minerals which react quickly (mostly magnesium) in well systems cause a slime on the inside of the coil which prevents adequate heat transfer. These minerals must be filtered out by a special incoming water filter or inhibited to protect the coil and also to provide acceptable water quality. The minerals contained in public water systems which accumulate in the coil over long periods of time may be removed when necessary by flushing the coil with cleaner. These products are also effective in cleaning a coil that is fouled by magnesium. **Flush entire system thoroughly after demineralizing process. Failure to do so will result in contaminated rinse water and severely shorten unit life.**

HIGH GAS CONSUMPTION

SEE ALSO CROSS CONTAMINATION

Improper burner operation caused by incorrect air/fuel ratio (CO_2 or O_2 out of the specified range) will cause high gas consumption. It is most noticeable on LP fired units with low CO_2 or high O_2 , however, units operating on LP or natural gas with incorrect air/fuel ratios will not provide their best efficiency. If no combustion analyzing equipment (CO_2 or O_2) is available an indication of the air/fuel ratio can be gotten by briefly sniffing the flue gases. When running properly the CSS-130's flue gases should have little smell. If they have a strong piercing smell the gas orifice is probably too small. Do not attempt to do reorificing without an O_2 or CO_2 kit.

SHORT CYCLING

SEE ALSO CROSS CONTAMINATION

The result of low flow is very rapid temperature rise in the heater. Sometimes the rise is so fast that the operating control will not operate before the safety limit operates. The heater will lockout and can only be restarted by resetting the manual reset button on the safety limit switch. (Where applicable.) If the on cycles are at least 1-1/2 minutes long then the short cycling will not be a problem .

CROSS CONTAMINATION AND COMBUSTION RELATED SHORT CYCLING

UNITS INSTALLED WITH QUICK VENT

Heater short cycling, nuisance lockouts and objectionable flue gas orders, may be caused by leakage of flue products into the combustion air stream. This results from poorly sealed joints in the inner (3") pipe. The symptom of this problem is continual restarts without a lockout occurring. The "VALVE/FLAME" light will be on for only a short time (but more than 6 seconds) before the post purge starts. This condition is generally seen on new installations; however, it is possible that a poorly assembled flue pipe could come apart and cause the same effect. Cross contamination can best be detected with a CO_2 analyzer (Bacharach® kit for example). Remove the stack switch tube from the "tee" fitting above the air orifice and connect the sampling tube of the analyzer to the "tee". Run heater and check CO_2 . If there is any measurable CO_2 , cross contamination exists somewhere in the flue system. If the heater will not operate long enough to get a CO_2 sample it is possible to check for cross contamination in another way. Loosen the top clamp on the air duct coupling and remove the gas balance line from the "tee fitting". Lift up the air induction elbow and twist it to the side so that air from the space around the heater can be drawn into the air duct coupling (do not disturb the air orifice in the coupling). Cover the air induction elbow with your hand or plug it with a rag and restart the heater. If no short cycling occurs there is a leak in the 3" flue pipe which must be corrected. Do not leave the heater operating in this manner. Re-assemble the air duct after removing plug (rag) and connect the balance line and stack switch tubes. Disassemble flue and fix leak.

LOCKOUTS

Integrated Heater Control Lockout - Possible Causes

- a. Cross Contamination
- b. Moisture in Combustion Chamber
- c. Gas Valve Malfunction
- d. Poor Combustion
- e. Boiler Control Malfunction
- f. Control Contact Failure
 - 1). Stack Switch
 - 2). Operating Control
- g. Failure of Air Source
- h. Igniter Failure

a.) If cross contamination is suspected see "Cross Contamination" and check for it. One percent CO₂ in the air duct can cause nuisance lockouts.

b.) Moisture in the combustion chamber will also cause lockouts by weakening the flame signal to the heater control. It should be suspected if the heater temperature does not rise above 160°F during long periods of operation. This condition can be caused by an improperly wired system circulator. On sidewall vented units moisture can get into the combustion chamber from a flue pipe that is pitched incorrectly (back toward the heater without a condensate trap). Quick Vented systems should always pitch down from the heater.

c.) A defective gas valve (one that doesn't always open properly) can cause a nuisance lockout however, occurrences like this are rare.

d.) A more common cause of nuisance lockouts is poor combustion. If there is an odor in the flue gases, this should be suspected. Check CO₂ or O₂ to determine if combustion is within limits. Poor combustion causes a weak flame signal to the burner control and lockouts may result.

e.) If combustion is within limits and none of the causes mentioned above seems to be the cause of the lockout it is possible that the heater control may be defective.

SEQUENCE OF OPERATION

On a call for heat from the tank thermostat on the CSS-130, the pump operates and the boiler control is energized through the operating control, pressure switch and the safety limit. It checks to ensure that the stack switch contacts are open and then energizes the blower. The blower starts and the air pressure increases until the stack switch contacts close and the red "PURGE" light lights. The pump and blower continue to run and for 15 seconds the red "PURGE" light stays on. Following that the red "PURGE" light goes out, the red "igniter" light lights and the igniter heats for 20 seconds. At the end of the 20 seconds the red "VALVEFLAME" light is lit and the gas valve is energized. For 2 seconds the valve and igniter are energized and burner will ignite. Following this the igniter is de-energized and the red "IGNITER" light goes out. The pump and blower continue to run and the burner operates under the supervision of the boiler control. If for any reason the full sequence is completed and the burner doesn't ignite, the sequence will be repeated after a blower "on" time of 45 seconds (30 seconds post purge and 15 seconds prepurge for the next cycle). During this part of the sequence the igniter remains on for 30 seconds and the balance of the sequence is unchanged. If no ignition occurs again a third cycle will follow with the same sequence as the second. After the third "trial for ignition" if the burner does not ignite the system will "lockout" and reset can only be accomplished by momentarily switching the power off. At the end of a heating cycle after the gas valve is de-energized, the blower will continue to run for a 30 second post purge. If normal burner operation during a heating cycle is interrupted by any of the limit controls the unit pump will continue to run and the blower will continue to operate for a 30 second post purge.

TROUBLESHOOTING (DETAILED FLOW CHARTS ON PAGES 20-26).

If the burner "lockout" for any reason the cause of failure will be displayed by the flashing of one of the lights.

CODE

- GREEN "POWER"** Light flashing - control failure, no light - no power.
- RED "PURGE"** Light flashing - blower or stack switch failure or possible flue blockage.
- RED "VALVEFLAME"** Light flashing - valve, igniter or flame sense failure (combustion related problem).

NOTE: If the stack switch contacts are closed for any reason when the blower isn't operating a sequence will not occur and after 45 seconds the control will lockout and the "PURGE" light will flash. If the stack switch contacts are open and do not close during purge period, after 5 minutes the control will lockout and the "PURGE" light will flash. If the boiler does not operate, the green "power" light is on and no indicator lights are flashing, check for an open pressure switch, low limit switch, operating control or safety limit switch on either series. For additional troubleshooting information refer to the troubleshooting flow charts on the pages that follow.

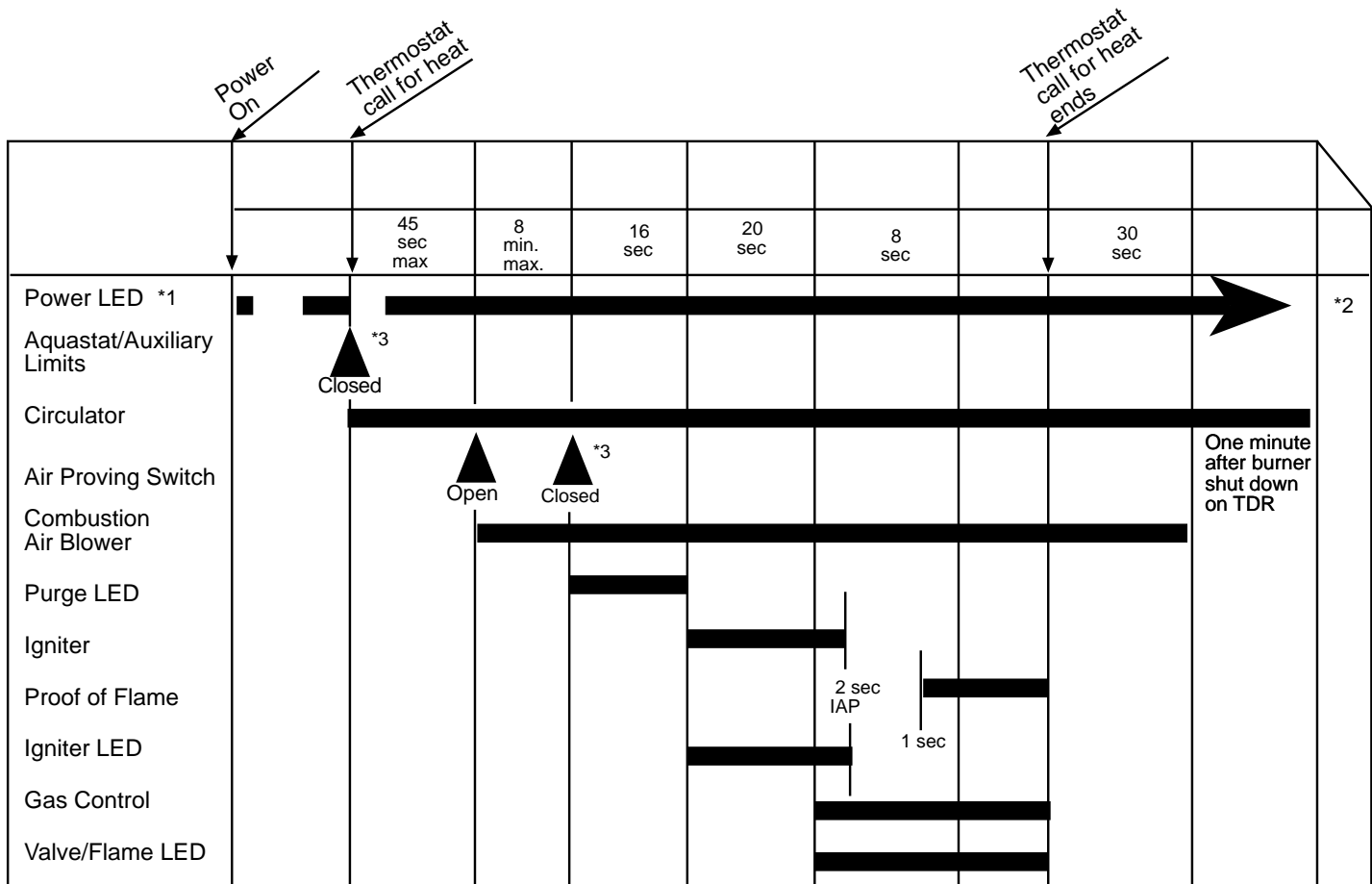

- *1. Power LED blinks once when 24V power is applied and when thermostat calls for heat.
- *2. On as long as control is powered and operating properly.
- *3. If either switch opens during the run cycle, burner will stop, followed by postpurge. Circulator will run as long as thermostat is calling for heat. Burner ignition sequence will restart if switch closes.

GENERAL TROUBLESHOOTING

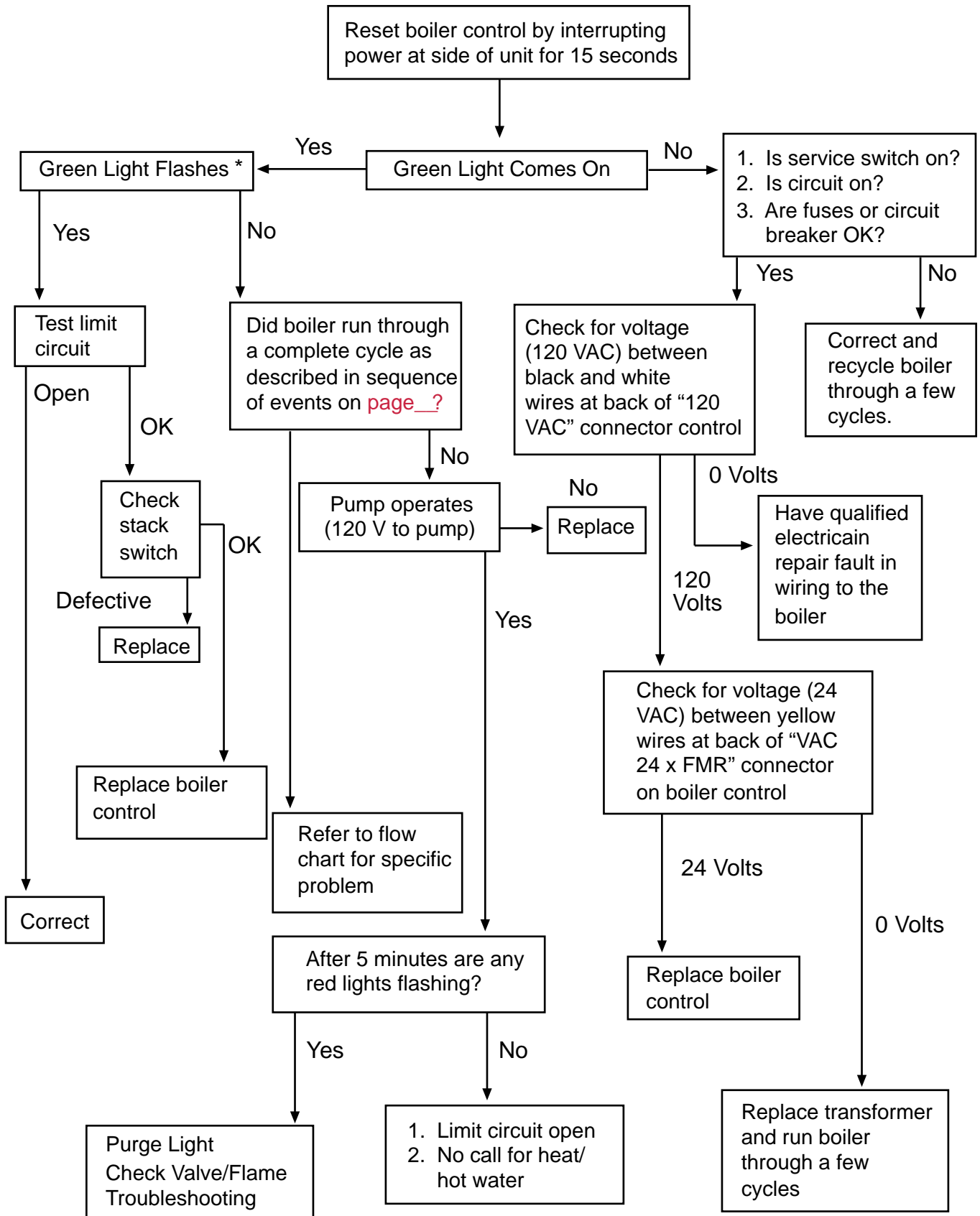

* Poor switch contact on relays or thermostats can cause a flashing green light.

TESTING LIMIT CIRCUIT

(Complete General Troubleshooting First)

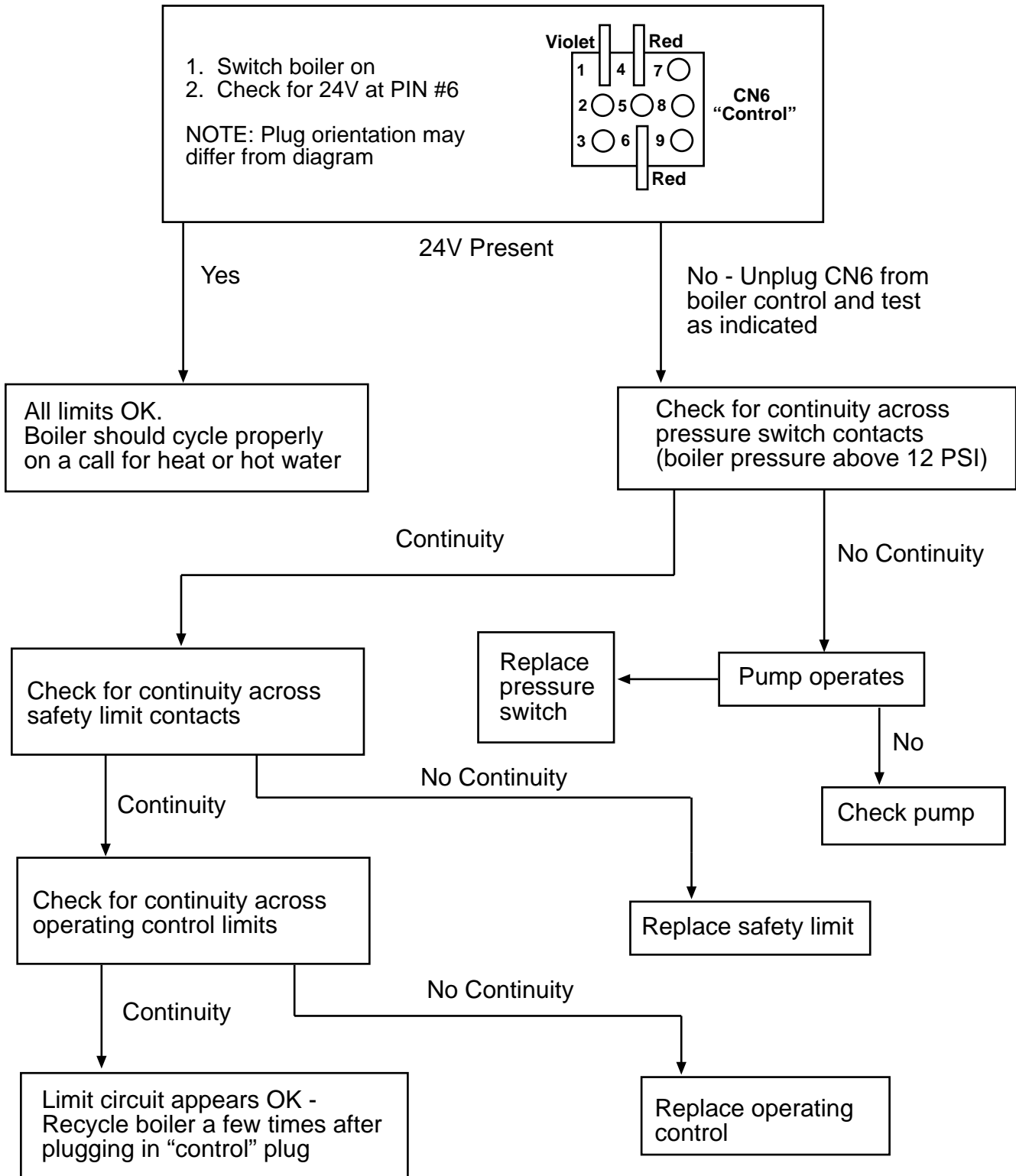

NOTE: After completing limit circuit testing, recycle boiler a few times. If boiler does not recycle, connect a jumper temporarily between the red wires. If boiler starts, remove jumper and temporarily jump each safety control until the defective control is located. NEVER leave a safety control jumped.

Red Purge Light Flashing

(Complete General Troubleshooting First)

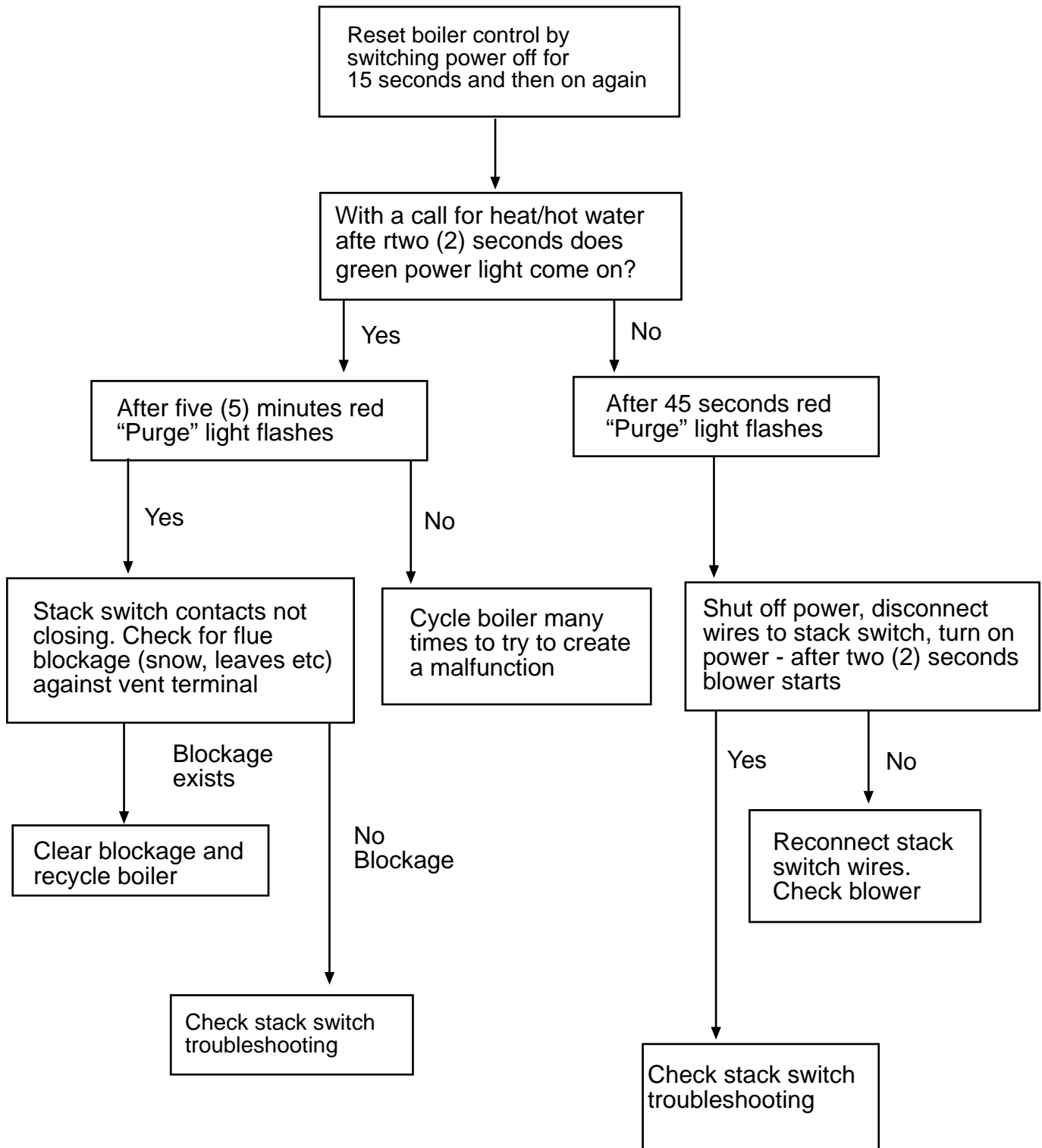

Checking Blower

(Complete General Troubleshooting First)

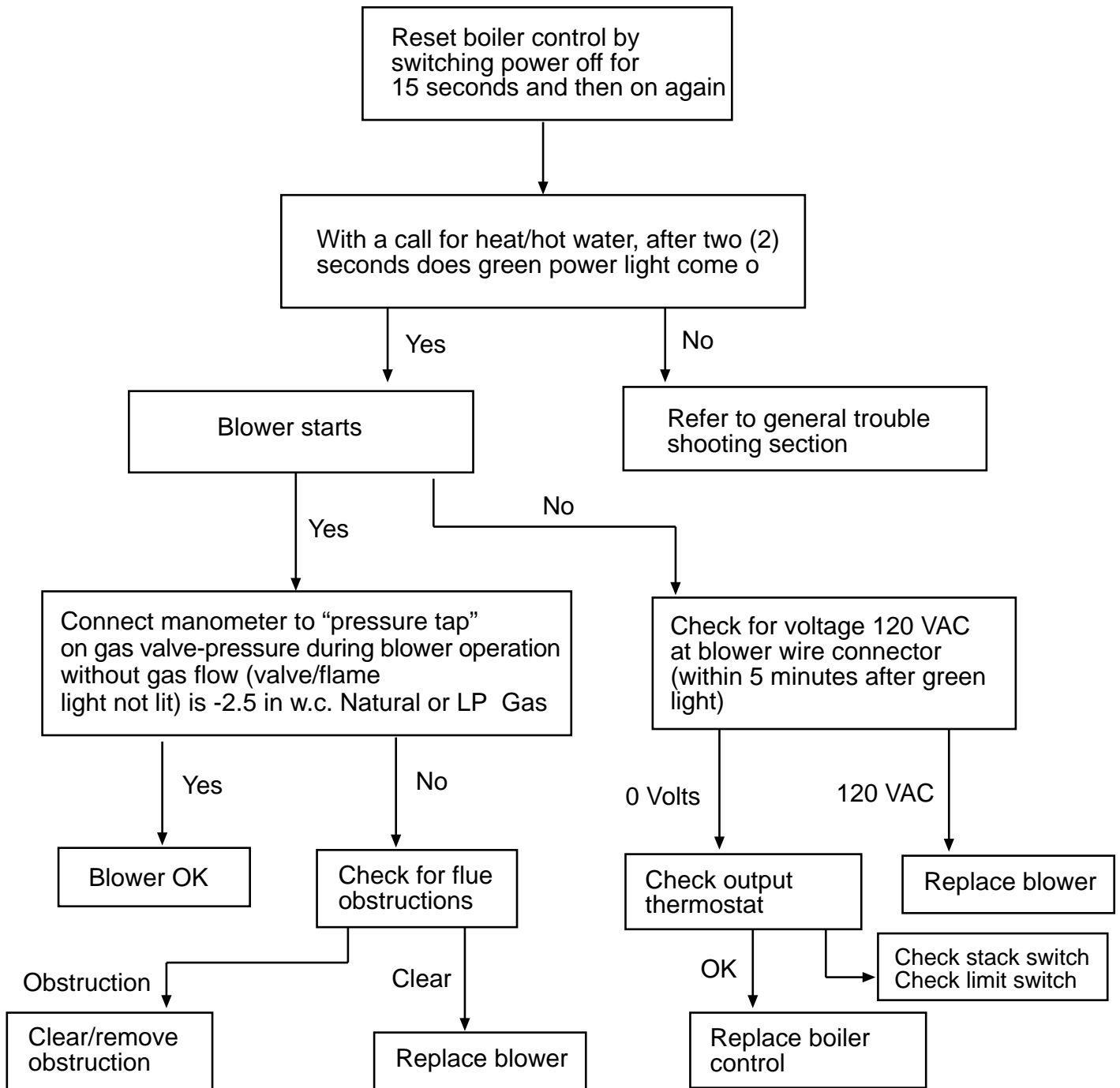

Checking Stack Switch

(Complete General Troubleshooting First)

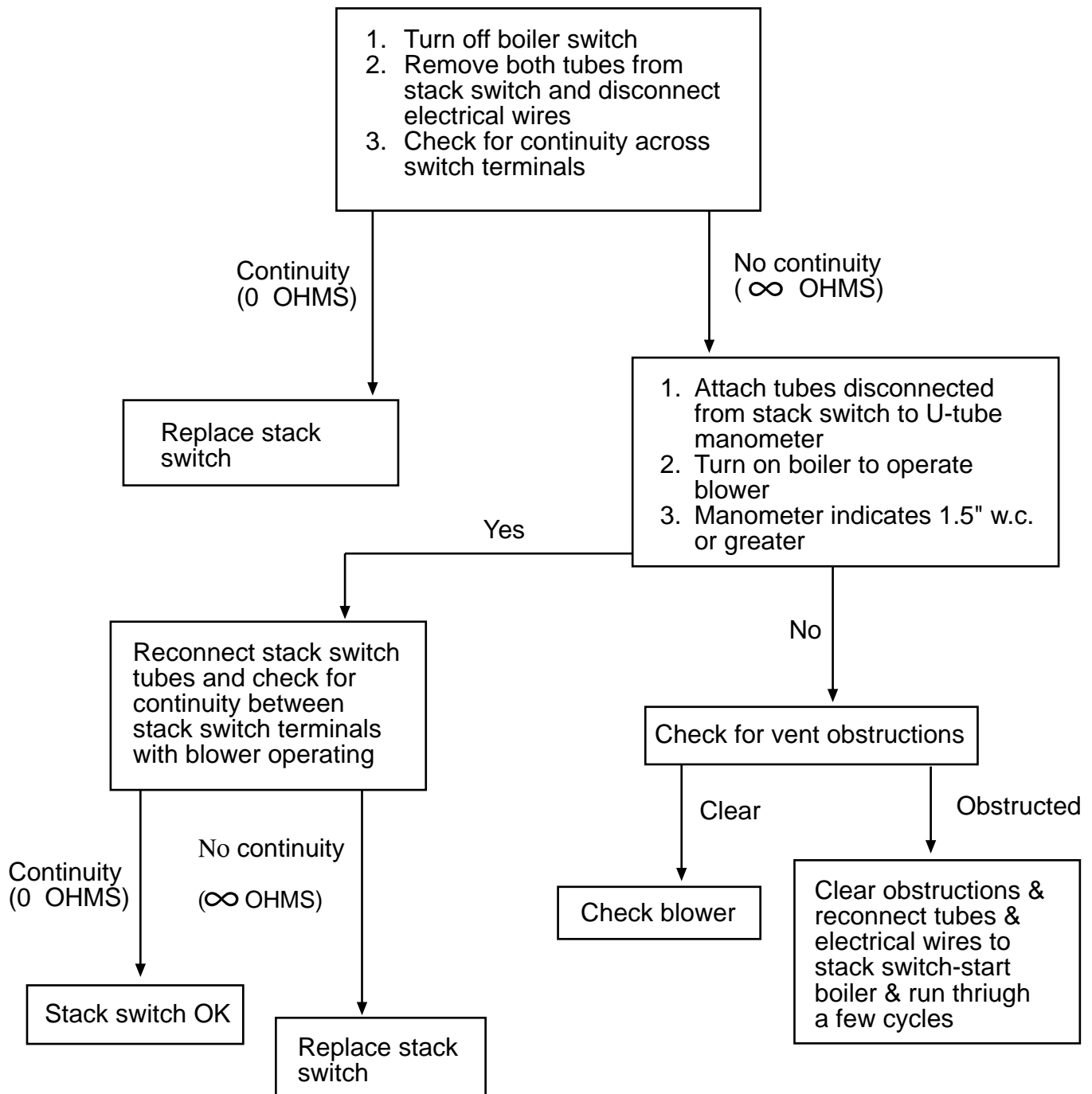

NOTE: Check tubes on stack switch for proper connections

Red "Valve/Flame" Light Flashing

(Complete General Troubleshooting First)

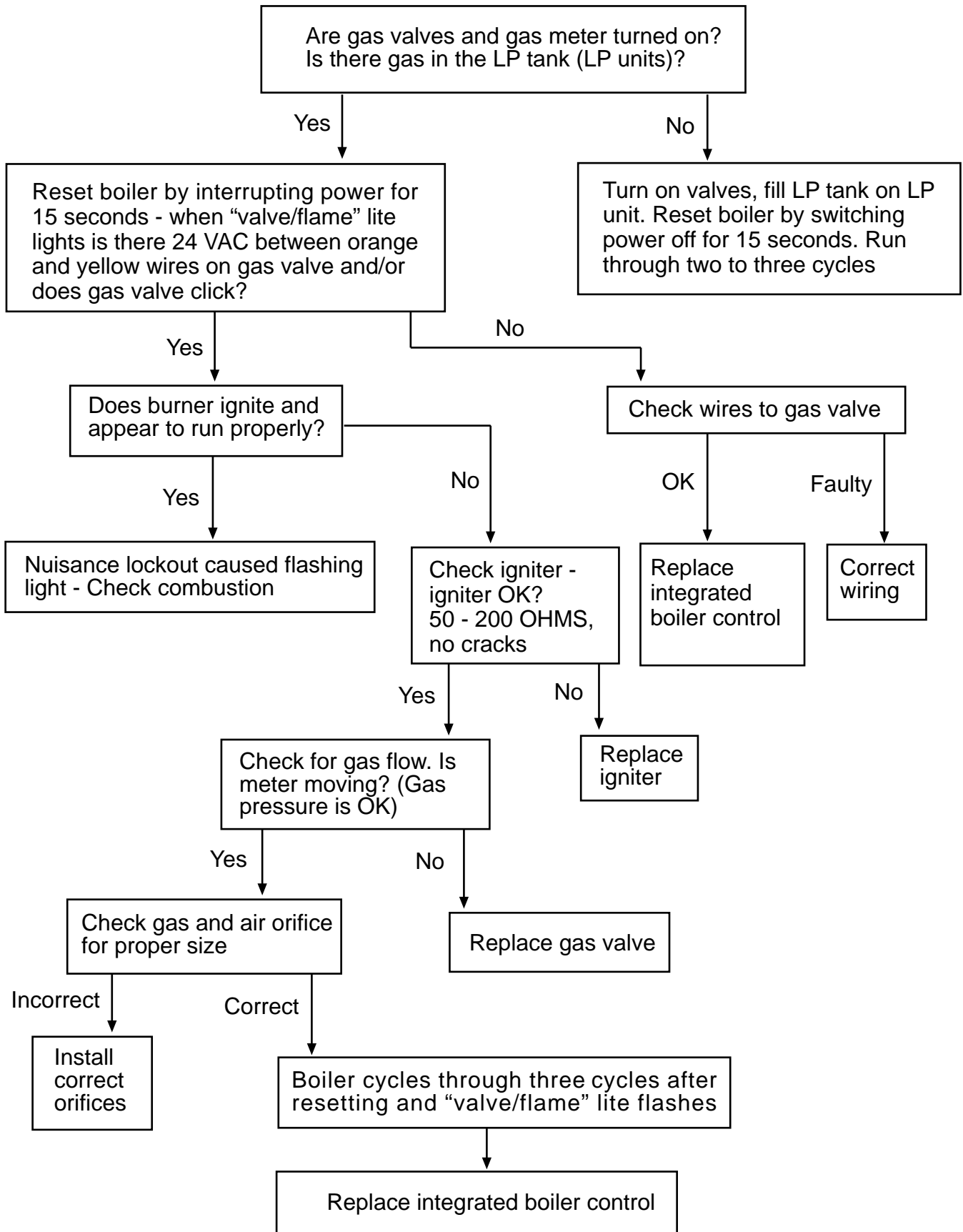

Checking Pump

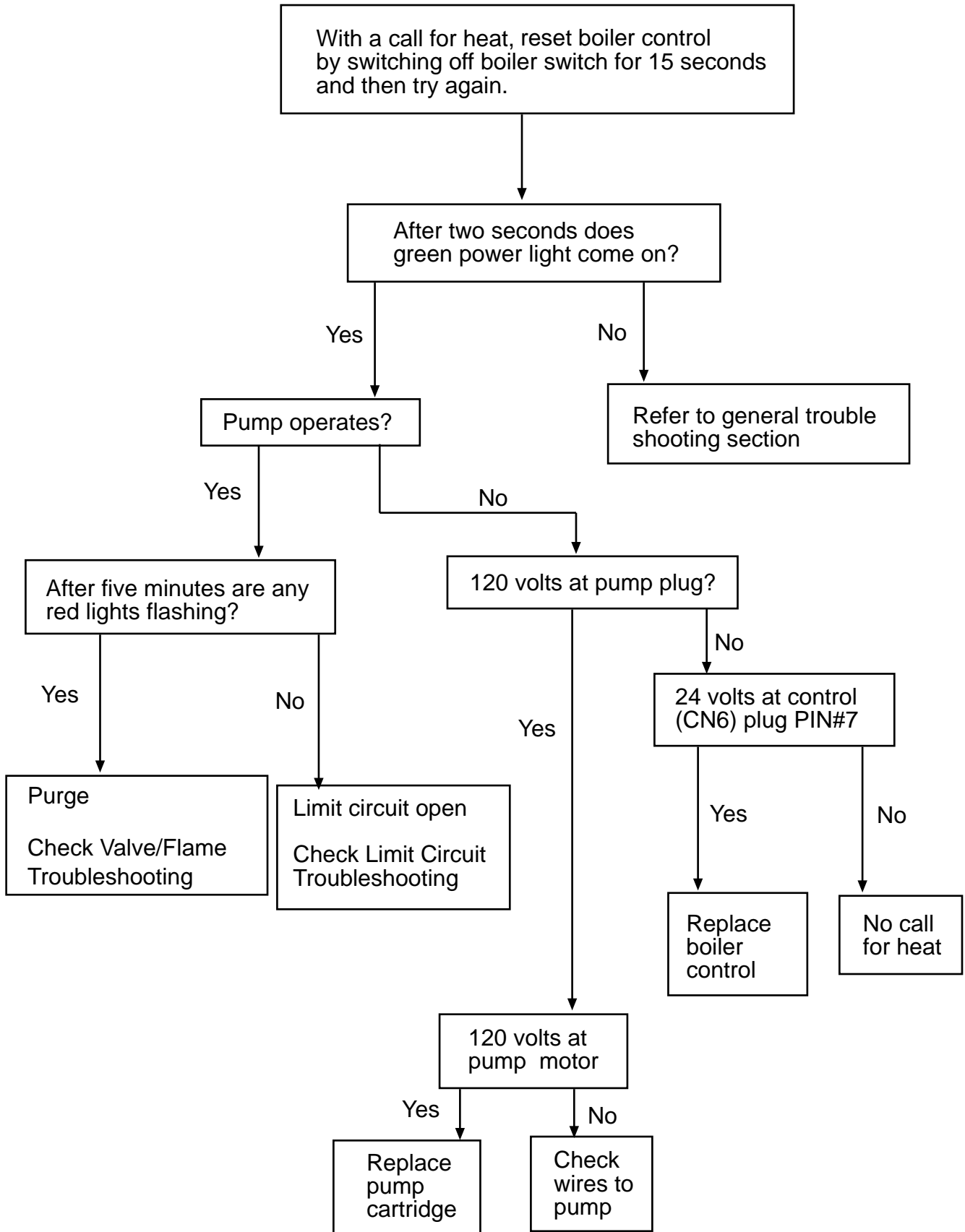

Quick Reference Trouble Shooter S9301A/G856DBG CONTROLS

1. Observe the Sequence		2. Failure to Complete Start Cycle	
Event	Control Function Verified	Comments	Potential Problem
A. Power switch on	Integrated boiler control (S9301A)	Green "Power" light on	1. No 120 VAC supply
			2. Defective 24 VAC transformer
			3. Defective S9301A
B. Pre-purge (if low limit or Thermostat calling) (2-17 sec)	1. Low limit (HW only) operating control, safety limit, system pressure switch, stack switch	Red "Purge" light on	1. Jump control wires, one control at a time to identify open circuit control (except stack switch)
	2. Blower		2. Check for 120 VAC between grey and white wires at back of (Inducer) plug
	3. Internal pump starts		3. Check for 120 VAC between brown & white wire at back of circulator plug or control
C. Igniter heats up and remains on (17-39 sec)	Igniter via S9301A	Red "Igniter" light on Red "Purge" light off Blower continues to run	Check for 120 VAC between blue wires at back of (Igniter) plug when red "Igniter" light is on
D. Gas valve energized (37-39 sec)	Igniter boiler control	Red "Valve/Flame" light on on Ignition Activation Period (IAP)	Check for 24 VAC between orange and yellow wires on gas valve when red "Valve/Flame" light is on
E. Igniter off (39 sec) Gas valve energized (39-43+ sec)	Igniter, air & gas source	Igniter monitors flame via flame rectification to ground	See trouble shooting section under "cross contamination" & "short cycling" in service manual

LADDER DIAGRAM

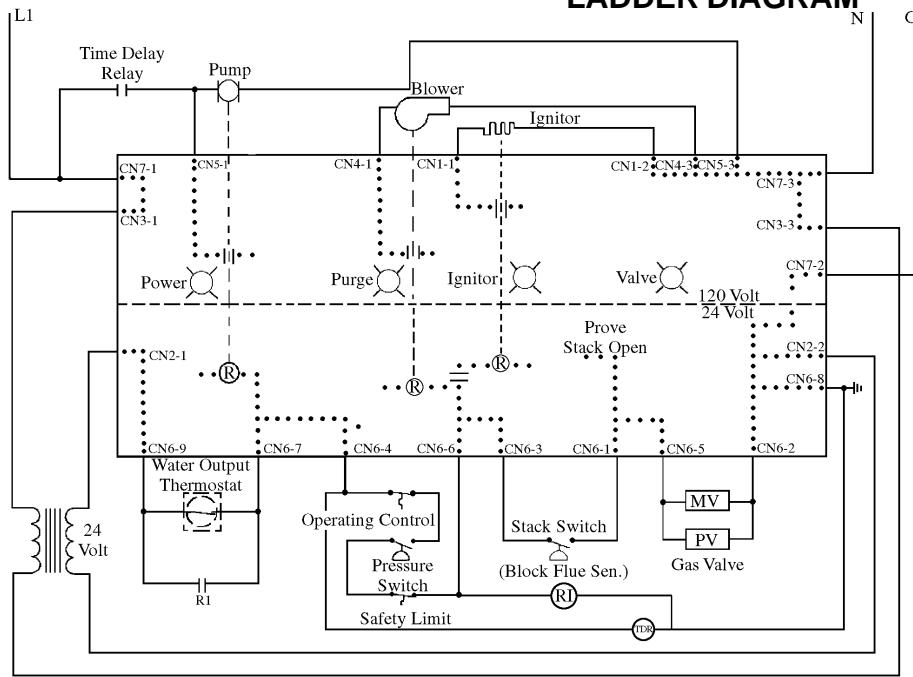

SCHEMATIC

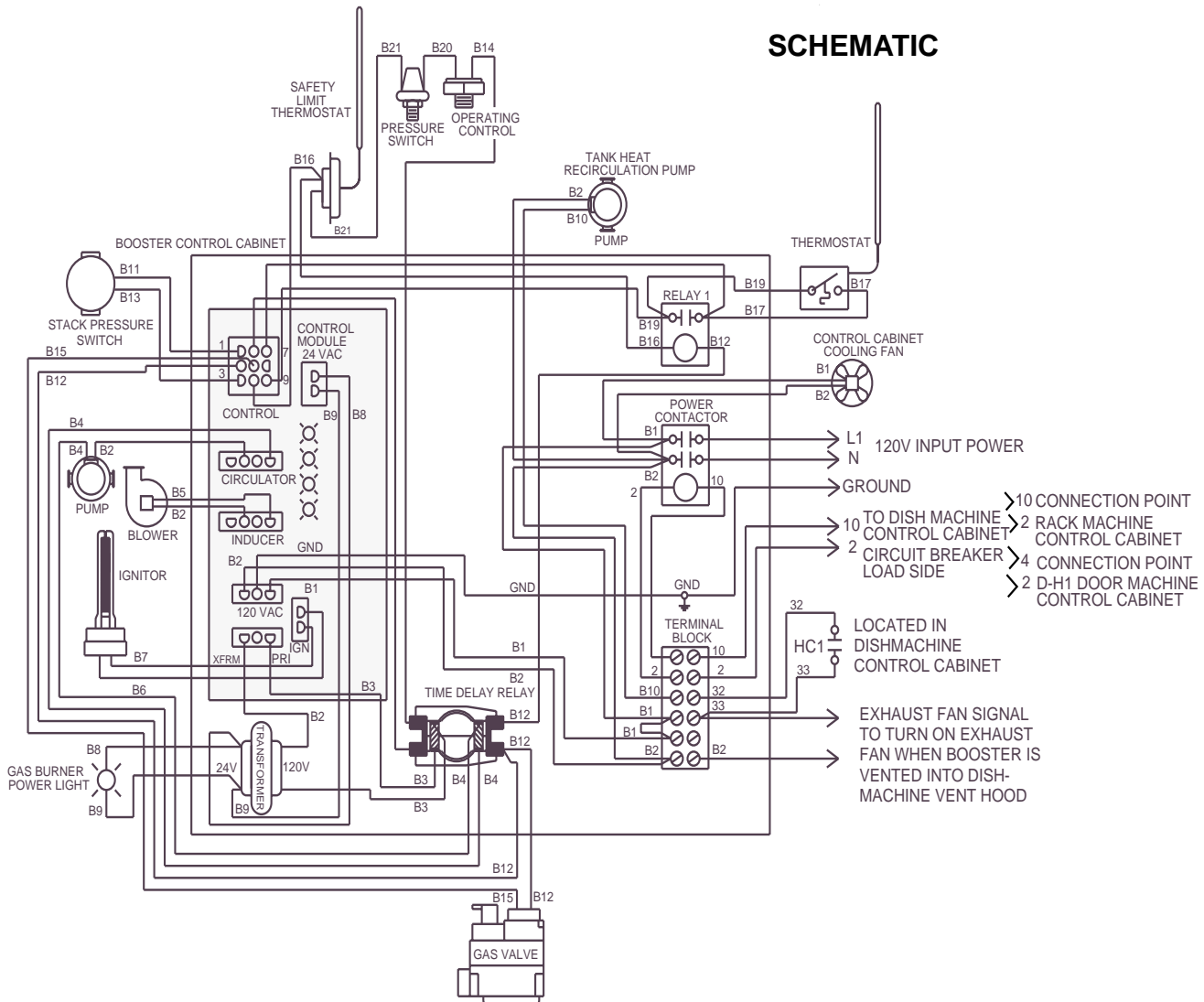

Figure 28
Electrical Diagrams

**This Page
Intentionally
Left Blank**

REPLACEMENT PARTS

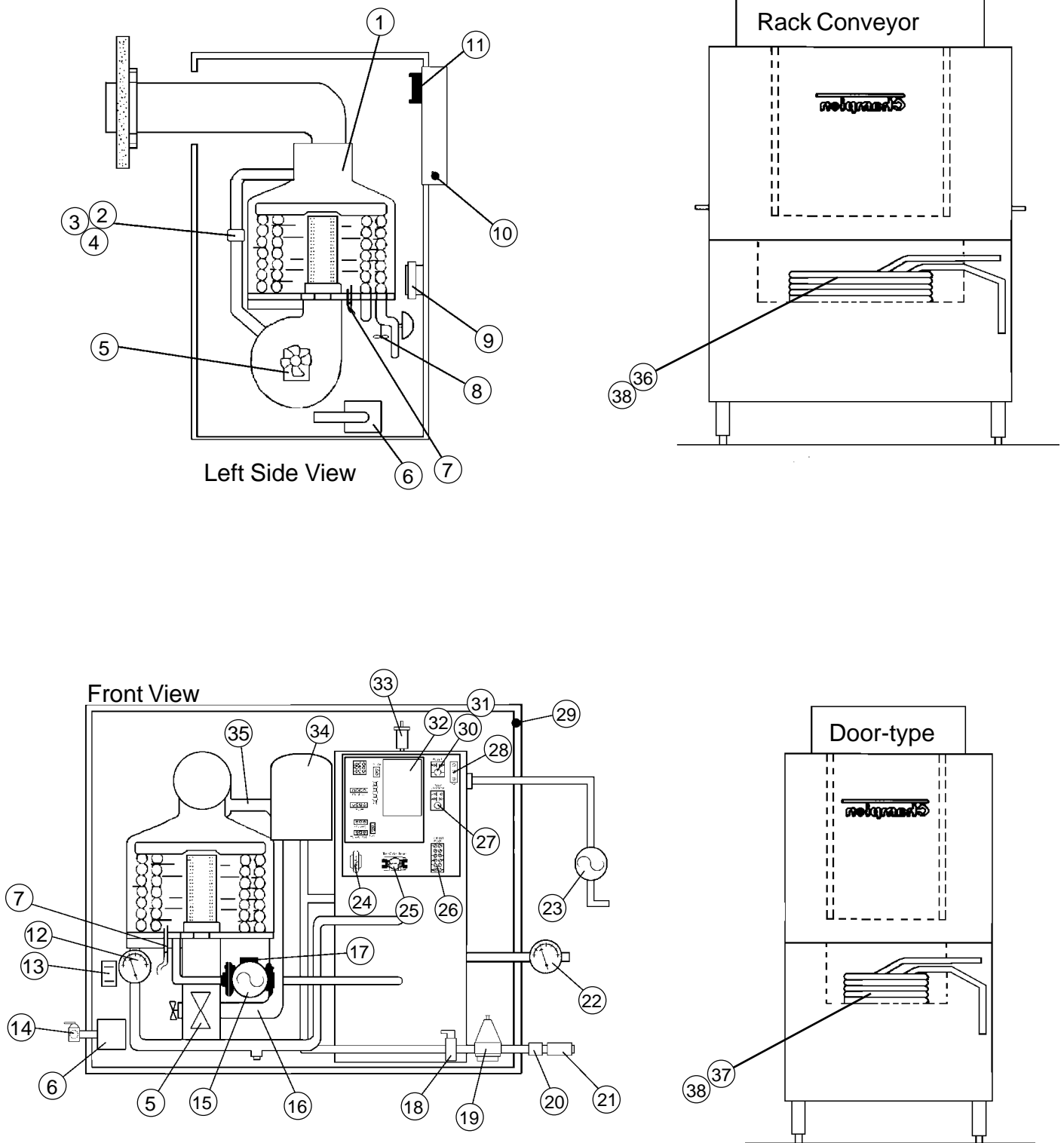

Figure 29
Parts Diagram

CSS-130 PARTS LIST
(For machines built after 7/7/97)

Fig. 29 Item No.	Part No.	Part Description	Qty.
1	112197	Boiler assembly (Includes Item #7)	1
2	112009	Clamp, hose	2
3	111950	Hose boot, air intake	1
4	111954	Orifice, air	1
5	111931	Blower assembly	1
6	111923	Valve, gas	1
—	111955	Orifice, natural gas	1
—	111993	Orifice, LP gas	1
7	111919	Ignitor (Includes gasket)	1
8	111951	Air bleed-off assembly	1
9	111928	Pressure switch, stack differential	1
10	111927	Thermostat, high limit	1
11	112083	Fan, control cabinet cooling	1
12	111930	Gauge, pressure/temperature	1
13	111924	Thermostat, operating control	1
14	112064	Valve, manually operated gas	1
15	111853	Pump, circulation (w/differential pressure switch ports)	1
16	111952	Lower inlet elbow assembly	1
17	111929	Pressure switch, circulation pump differential	1
18	112290	Eliminator, air	1
19	112429	Valve, water pressure reducing	1
20	100853	Valve, check	1
22	104682	Thermometer	1
21	111746	Back flow preventer	1
23	111854	Pump, circulation	1
24	111277	Transformer, 24VAC	1
25	111925	Relay, time delay	1
26	100294	Strip, terminal	1
27	107369	Contactactor, power	1
28	109069	Thermostat, control	1
29	112188	Lamp, power indicator	1
30	111067	Relay, control 24VAC	1
31	111036	Socket, relay	1
32	111926	Module, (Ignition) boiler control	1
33	111852	Vent, high	1
34	111745	Tank, expansion	1
35	111953	Upper inlet elbow assembly	1
36	317943	Coil, heat exchanger (44-66WS rack conveyor)	1
37	317893	Coil, heat exchanger (D-H1 door-type)	1
38	100123	Gauge, cock	1
—	112043	Valve, pressure relief (3/4", 30 PSI) (Not shown)	1
—	100135	Gauge, pressure (Not shown)	1
—	103309	Lug, ground (Not shown)	1
—	112228	Valve, angle drain 1/2"	1