

CECILWARE

43-05 20th Ave LIC, NY 11105 i Tel: (800) 935-2211 i (718) 932-1414 i Fax: (718) 932-7860 i www.cecilware.com

MT-2UL-BL, MT-3UL-BL

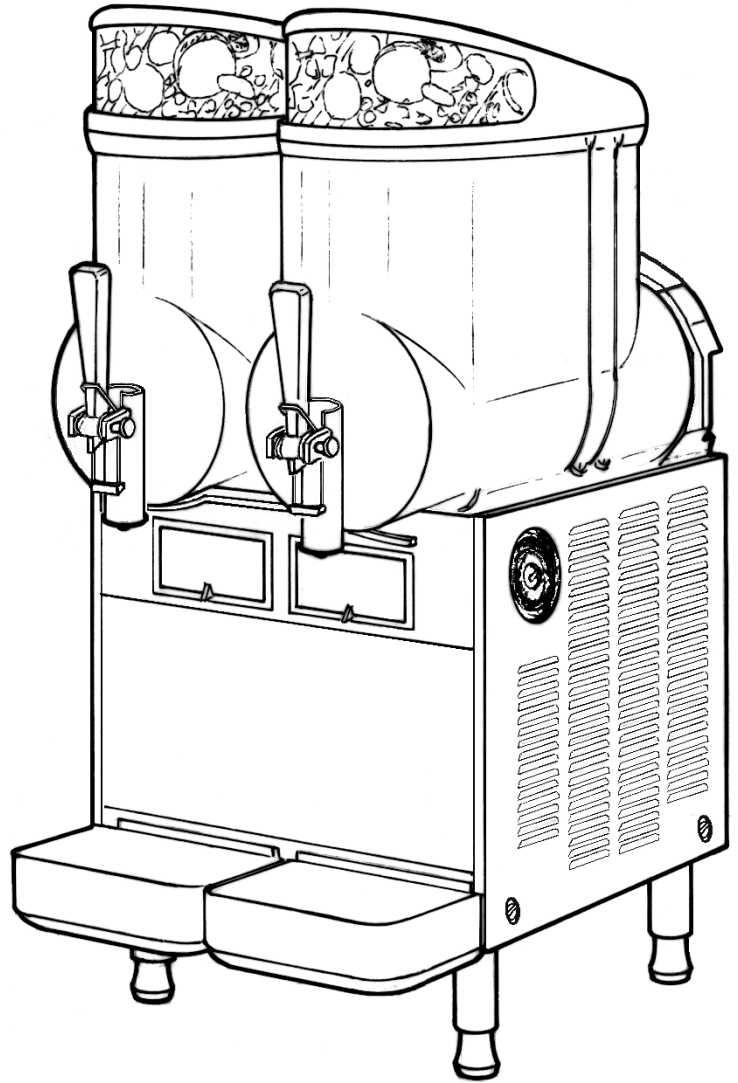

OPERATOR'S MANUAL

TABLE OF CONTENTS

1	TECHNICAL CHARACTERISTICS	5
2	INTRODUCTION	5
3	INSTALLATION	5
4	TO OPERATE SAFELY	5
5	OPERATING PROCEDURES	6
5.1	DESCRIPTION OF CONTROLS	6
5.2	OPERATION HELPFUL HINTS	7
5.3	CLEANING AND SANITIZING PROCEDURES	7
5.3.1	DISASSEMBLY	7
5.3.2	CLEANING	9
5.3.3	SANITIZING	9
5.3.4	ASSEMBLY	9
5.4	IN-PLACE SANITIZATION	10
6	ROUTINE MAINTENANCE	10
6.1	MAINTENANCE (TO BE CARRIED OUT BY QUALIFIED SERVICE PERSONNEL ONLY)	10
7	DEFROST TIMER (OPTIONAL)	11

This dispenser is manufactured under one or more of the following U.S.patents and/or other pending patents:

**U.S.A. 4,900,158
U.S.A. 4,696,417
U.S.A. 5,713,214
U.S.A. 5,906,105**

1 TECHNICAL CHARACTERISTICS

		MT 2 UL BL	MT 3 UL BL
Transparent removable bowls	n	2	3
Capacity of each bowl, approx.	Gal	2.5	2.5
Dimensions:			
width	Inches	14.25	21
depth	Inches	18.5	18.5
height	Inches	27.75	27.75
Net weight, approx.	kg	81.5	108
Gross weight, approx.	kg	95	125
Adjustable thermostats	n	2	3
Hermetic compressor			
Air-cooled condenser			
Safety pressure switch			
Noise level lower than 70 dB (A)			

IMPORTANT

Read electrical ratings written on the data plate of the individual units; the data plate is adhered on the dispensing side panel of the unit, just behind the drip tray (the right side drip tray in multiple bowl models). The serial number of the unit (preceded by the symbol #) is adhered inside the left switch box. Data plate specifications will always supersede the information in this manual.

The electric diagram of the dispenser is located in the inner part of the dispensing side panel.

Specifications are subject to change without notice.

2 INTRODUCTION

Please read all sections of this manual thoroughly to familiarize yourself with all aspects of the unit. Like all mechanical products, this machine will require cleaning and maintenance. Besides, dispenser working can be compromised by operator's mistakes during disassembly and cleaning. It is strongly recommended that personnel responsible for the equipment's daily operations, disassembly, cleaning, sanitizing and assembly, go through these procedures in order to be properly trained and to make sure that no misunderstandings exist.

3 INSTALLATION

- 1 - Remove the corrugate container and packing materials and keep them for possible future use.

IMPORTANT

When handling the machine never grasp it by the bowls or by the evaporator cylinders. The manufacturer refuses all responsibilities for possible damages which may occur through incorrect handling.

- 2 - Inspect the uncrated unit for any possible damage. If

damage is found, call the delivering carrier immediately to file a claim.

- 3 - Install the unit on a counter top that will support the combined weight of dispenser and product **bearing in mind what is stated in the preceding point 1 IMPORTANT warning.**
- 4 - A minimum of 15 cm (6") of free air space all around the unit should be allowed to guarantee adequate ventilation.
- 5 - Ensure that the legs are screwed tightly into the base of the machine.
Replace the standard legs originally installed with the 100 mm (4") legs whenever they are provided with the unit.
- 6 - Before plugging the unit in, check if the voltage is the same as that indicated on the data plate. Plug the unit into a grounded, protected single phase electrical supply according to the applicable electrical codes and the specifications of your machine. When the unit has no plug, install a proper grounded plug, in compliance with electrical codes in force in your area, suitable to at least 10 Amp 250 Volt (220-230 Volts 50-60 Hz areas) and 20 Amp 250 Volt (100-115 Volts 50-60 Hz areas) applications. Should you prefer to connect the unit directly to the mains, connect the supply cord to a 2-pole wall breaker, whose contact opening is at least 0.125". Do not use extension cords.

ATTENTION

Failure to provide proper electrical ground according to applicable electrical codes could result in serious shock hazard.

- 7 - The unit doesn't come presanitized from the factory. Before serving products, the dispenser must be disassembled, cleaned and sanitized. according to this handbook instructions (chapter 5.3 CLEANING AND SANITIZING PROCEDURES).

4 TO OPERATE SAFELY

- 1 - **Do not** operate the dispenser without reading this operator's manual.
- 2 - **Do not** operate the dispenser unless it is properly grounded.
- 3 - **Do not** use extension cords to connect the dispenser.
- 4 - **Do not** operate the dispenser unless all panels are restrained with screws.
- 5 - **Do not** obstruct air intake and discharge openings: 15 cm (6") minimum air space all around the dispenser.
- 6 - **Do not** put objects or fingers in panels louvers and faucet outlet.
- 7 - **Do not** remove bowls, augers and panels for cleaning or routine maintenance unless the dispenser is disconnected from its power source.

5 OPERATING PROCEDURES

ATTENTION

In case of damages, the power cord must be replaced by qualified personnel only in order to prevent any shock hazard.

- 1 - Clean and sanitize the unit according to the instructions in this manual. See chapter 5.3 CLEANING AND SANITIZING PROCEDURES.
- 2 - Fill the bowls with product to the maximum level mark. Do not overfill.
The exact quantity of product (expressed as liters and

gallons) is shown by marks on the bowl.

- 3 - In case of products to be diluted with water, pour water into bowl first, then add correct quantity of product. In case of natural squashes, it is advisable to strain them, in order to prevent pulps from obstructing the faucet outlet.
- 4 - To obtain the best performance and result, use bases designed to be run in Granita freezers. Such bases have a sugar content of 34 degrees Baumé corresponding to 64 degrees Brix.
For soft drinks the bases are to be diluted with more water, on a 1 plus 5/5.5 basis.
In any case follow the syrup manufacturer's instructions for both Granita and soft drink recipes.
If natural juices (e.g. lemon, orange) as well as sugarless products (e.g. coffee) are used, dissolve 5.3 - 7 oz of sugar per 0.25 gallons.

▶ IMPORTANT

However Granita mix may be done, its Brix (sugar percent content) must be at least 13.

▶ IMPORTANT

Operate the dispenser with food products only.

- 5 - Install the covers and check that they are correctly placed over the bowls. The dispenser must always run with the covers installed to prevent a possible contamination of the product.
- 6 - Set the control switches as shown in chapter 5.1 DESCRIPTION OF CONTROLS.
- 7 - Always leave the dispenser on, as the refrigeration stops automatically when Granita reaches the proper thickness. The mixers will continue to turn.

5. 1 DESCRIPTION OF CONTROLS

The dispenser is equipped with a power switch and a light switch. In addition each bowl is individually operated by a mixer/refrigeration switch. In fact it is possible to dispense both soft drinks and Granita. When a bowl is in Soft Drink mode the beverage temperature is controlled by the corresponding thermostat. When a bowl is in Granita mode the mix viscosity is controlled by the corresponding adjustment screw located in the rear wall of each container (for temperature and viscosity setting make reference to chapter 5.2 OPERATION HELPFUL HINTS). All the switches are located on the faucet side of the dispenser in switch panels protected by switch covers (see figure 1).

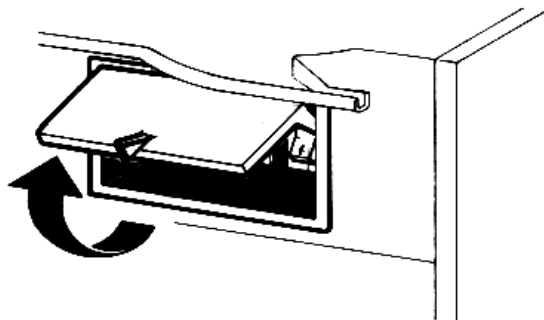

figure 1

With reference to figure 3 dispenser controls functions are as

follows:

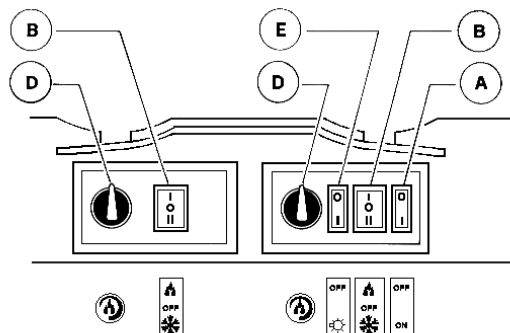

figure 2

Power switch (A)

- 0 position : power is turned OFF to all functions.
- I position : power is turned ON to all functions and the other switches are enabled. The fan motor runs.

Light switch (E)

- 0 position : all top cover lights are OFF.
- I position : all top cover lights are ON, provided that power switch (A) is set to I.

Mixer/refrigeration switch (B)

- I position : mixer and refrigeration ON. SOFT DRINK mode.
- 0 position : OFF.
- II position : mixer and refrigeration ON. GRANITA mode.

Thermostat (D)

- Turn clockwise : to decrease temperature
- Turn counterclockwise : to increase temperature

To operate the unit:

- 1 - Set the power switch to I position.
- 2 - Set the mixer/refrigeration switches as follows:
 - to the I position to get soft drink.
 - to the II position to get Granita.
- 3 - Set the light switch to I position.

5. 2 OPERATION HELPFUL HINTS

- 1 - **Granita viscosity adjustment:** proper Granita viscosity is factory preset. To change the viscosity, if needed, use a standard screwdriver to turn the adjustment screw located in the rear wall of each container as follows (see figure 3):
 - towards right (clockwise) to obtain a thicker product (the indicator F will go down in opening G).
 - towards left (counterclockwise) to obtain a thinner product (the indicator F will go up in opening G).

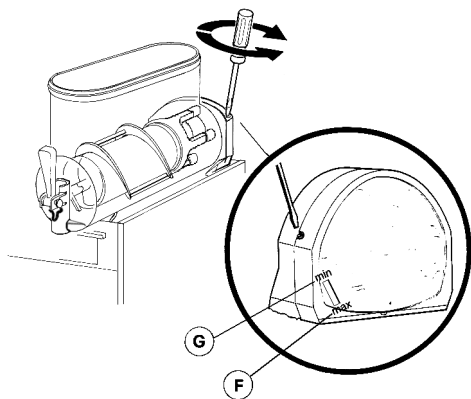

figure 3

- 2 - **Beverage temperature adjustment:** proper beverage temperature is factory preset. To reset, turn the knob located in each switch box as follows:
 - towards right (clockwise) to decrease temperature.
 - towards left (counterclockwise) to increase temperature.**Note: beverage temperature is controlled by the thermostat only when the mixer/refrigeration switch(es) are in I position, Soft Drink mode.**
- 3 - When the mixer / refrigeration switch(es) are set in I position, Soft Drink mode, it is possible to manually switch off the refrigeration by turning completely towards left (counterclockwise) the thermostat knob until it clicks.
- 4 - The length of time for freeze down of Granita is governed by many variables, such as ambient temperature, mix initial temperature, sugar content (Brix level) and viscosity setting.
- 5 - To shorten Granita recovery time and increase productivity, it is advisable to pre-chill the product to be used in the dispenser.
- 6 - To shorten Granita recovery time and increase productivity, the bowl should be refilled after the product level drops lower than half of the evaporator cylinder and at the start of each day.
- 7 - For good product conservation the dispenser must run overnight, at least in Soft Drink mode.
If this is not possible and product is left in the bowls overnight, the mixer/refrigeration switches must be set to the I position at least one hour before the unit is switched off. This eliminates any block of iced product forming overnight, which could result in damage to mixers or to their motor when the unit is switched back on. In any case, before the unit is restarted, make sure that no blocks of ice have been formed; if so, they are to be removed before the unit is switched on. Overnight operation in drink mode also eliminates possible ice accumulation from condensation all around the bowls.
- 8 - Mixers must not be turned off when frozen product is in the bowl: if not agitated, the product may freeze to a solid block of ice. If the mixers are turned back on in this situation, damage to the mixers and their motor may result. Therefore, mixers may be restarted only after product is melted.
- 9 - The dispenser is equipped with a magnetic coupling by which the gear motor (located outside the bowl) drives the mixers (inside the bowl). The magnetic drive operates as an "intelligent clutch" able to automatically disconnect the mixers in case they are seized by ice or other causes. This inconvenience can be soon noticed since an intermittent dull noise warns that mixers are still. In this case it is necessary to unplug immediately the dispenser, empty the bowl and eliminate the cause of seizing.
- 10 - The dispenser must be able to emit heat. In case it seems excessive, check that no heating source is close to the unit and air flow through the slotted panels is not obstructed by wall or boxes. Allow at least 15 cm (6") of free clearance all around the dispenser.

- 11 - Restrictor cap: when the unit is used in Soft Drink mode it is advisable to install the restrictor cap on the faucet outlet in order to reduce the drink outflow (see figure 4).

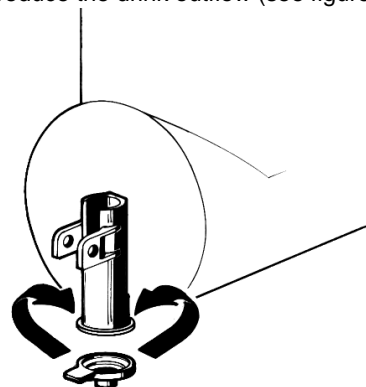

figure 4

5. 3 CLEANING AND SANITIZING PROCEDURES

- 1 - Cleaning and sanitizing of the dispenser are recommended to guarantee the conservation of the best product taste and the highest unit efficiency. This section is a procedural guideline only and is subject to the requirements of the local Health Authorities.
- 2 - Prior to the disassembly and cleaning, the machine must be emptied of product. To do this proceed as follows:
 - set the power switch to I position
 - set mixer/refrigeration switch(es) to I position (Soft Drink mode)
 - place a pail under each faucet and drain all product from bowls
 - set all control switches to the 0 position.

5. 3. 1 DISASSEMBLY

ATTENTION

Before any disassembly and/or cleaning procedure make sure that the dispenser is disconnected from its power source.

- 1 - Remove cover from the bowl.
- 2 - Remove the bowl by lifting its faucet side up and off the fastening hooks (see figure 5) and slide it out (see figure 6).

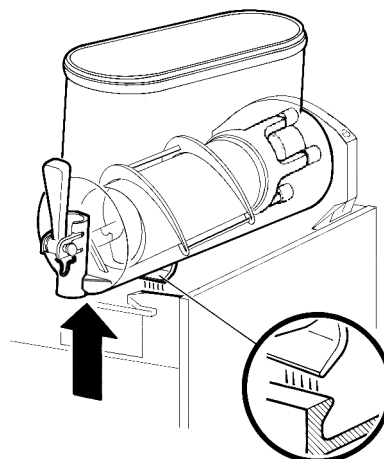

figure 5

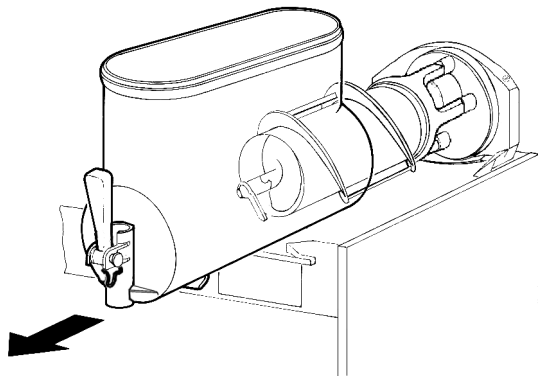

figure 6

3 - Slide the outer spiral out (see figure 7) and then the inside auger (see figure 8).

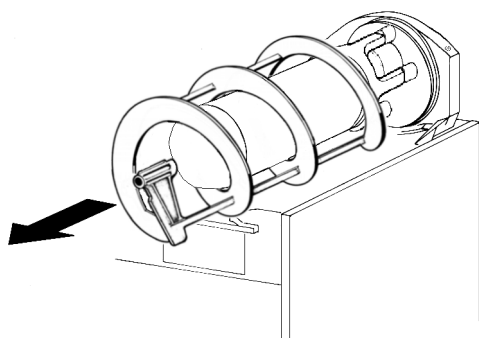

figure 7

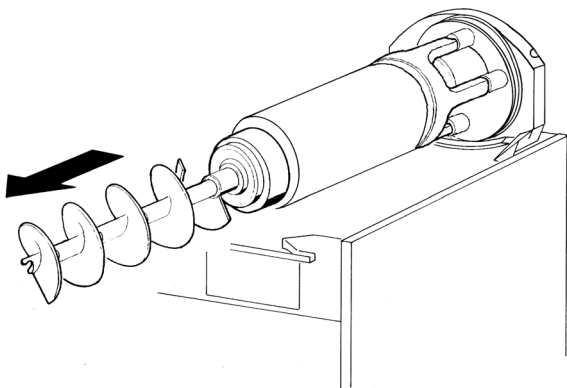

figure 8

4 - Remove the bowl gasket from its seat (see figure 9).

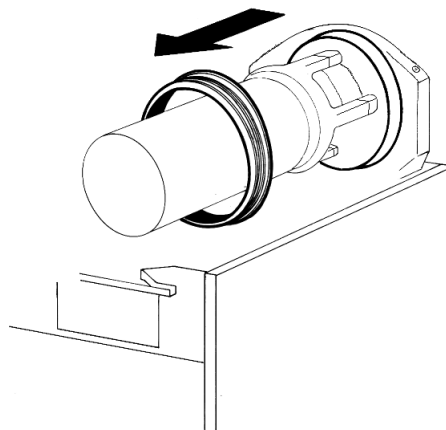

figure 9

5 - Dismantle the faucet assembly (see figure 10).

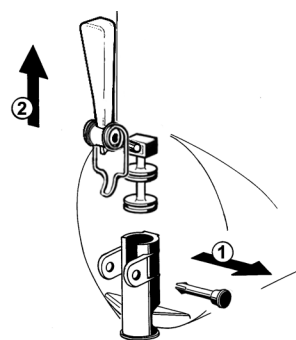



figure 10

6 - Slide the drip tray out and empty it.

5. 3. 2 CLEANING

 **ATTENTION**

Before any disassembly and/or cleaning procedure make sure that the dispenser is disconnected from its power source.

 **IMPORTANT**

Do not attempt to wash any machine components in a dishwasher.

1 - Prepare at least two gallons of a mild cleaning solution of warm (45-60 °C / 120-140 °F) potable water and dishwashing detergent. Do not use abrasive detergent. Important: if present, follow label directions, as too strong a solution can cause parts damage, while too mild a

solution will not provide adequate cleaning.

IMPORTANT

In order to prevent any damages to the dispenser use only a detergent suitable with plastic parts.

- 2 - Using a brush, suitable for the purpose, thoroughly clean all disassembled parts in the cleaning solution.

ATTENTION

When cleaning the machine, do not allow excessive amounts of water around the electrically operated components of the unit. Electrical shock or damage to the machine may result.

- 3 - Do not immerse the lighted top covers in liquid. Wash them apart with the cleaning solution. Carefully clean their undersides.
- 4 - In the same manner clean the evaporator cylinder(s) using a soft bristle brush.
- 5 - Rinse all cleaned parts with cool clean water.

5. 3. 3 SANITIZING

Sanitizing should be performed immediately prior to starting the machine. Do not allow the unit to sit for extended periods of time after sanitization.

- 1 - Wash hands with a suitable antibacterial soap.
- 2 - Prepare at least two gallons of a warm (45-60 °C / 120-140 °F) sanitizing solution (100 PPM available chlorine concentration or 1 spoon of sodium hypochlorite diluted with half a gallon of water) according to your local Health Codes and manufacturer's specifications.
- 3 - Place the parts in the sanitizing solution for five minutes.
- 4 - Do not immerse the lighted top covers in liquid. Carefully wash their undersides with the sanitizing solution.
- 5 - Place the sanitized parts on a clean dry surface to air dry.
- 6 - Wipe clean all exterior surfaces of the unit. Do not use abrasive cleaner.

5. 3. 4 ASSEMBLY

- 1 - Slide the drip tray into place.
- 2 - Lubricate faucet piston, inside auger and outer spiral (see points A, B and C of figure 11) only with the grease supplied by the manufacturer or other **food grade approved** lubricant.

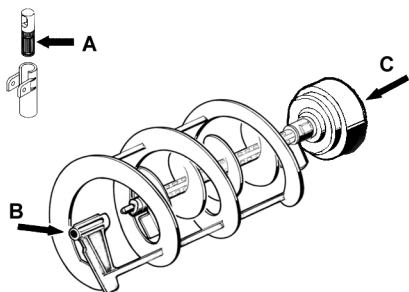

figure 11

- 3 - Assemble the faucet by reversing the disassembly steps (see figure 10)
- 4 - Fit bowl gasket around its seat.
Note: the largest brim of gasket must face against the rear

wall (see figure 12).

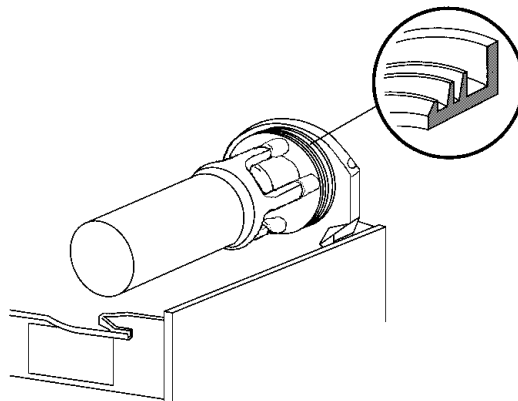

figure 12

- 5 - Insert the auger into the evaporator taking care to accompany it to the end so as to prevent it from hitting against the rear wall (see figure 13).

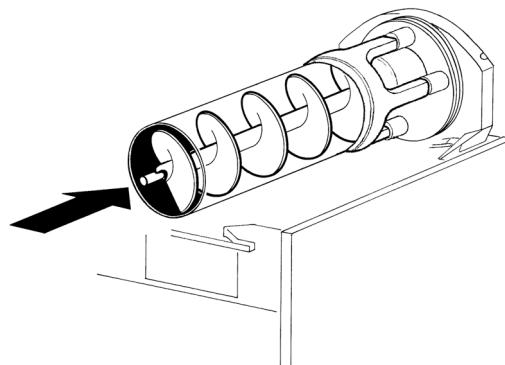

figure 13

- 6 - Install the outer spiral. Slide it over the evaporator until its front notch engages with the exposed end of the auger shaft (see figure 14).

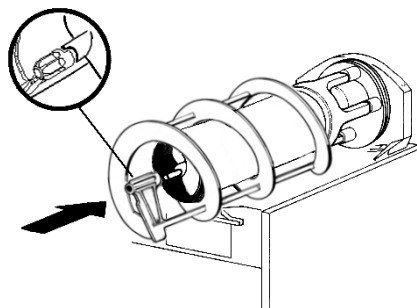

figure 14

- 7 - Push the bowl towards the rear wall of the unit until it fits snugly around the gasket and its front fastening hooks are

properly engaged (see figure 15).

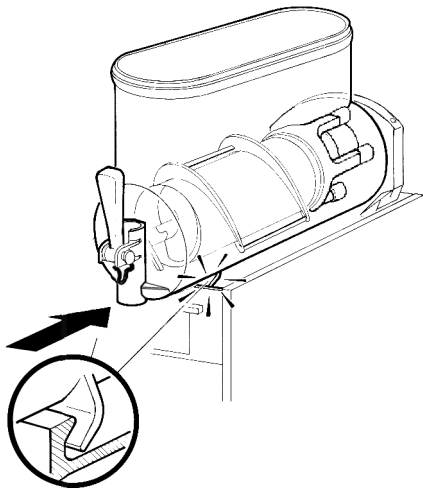

figure 15

- 8 - Use fresh product to chase any remaining sanitizer from the bottom of the bowl(s). Drain this solution. Do not rinse out the machine.

5. 4 IN-PLACE SANITIZATION

The In-Place Sanitization prior to starting the machine may be performed, if needed, only as further precaution, in addition to the Disassembled Parts Sanitization described before, but never in lieu of it.

- 1 - Prepare two gallons of a warm (45-60°C / 120-140 °F) sanitizing solution (100 PPM available chlorine concentration or 1 spoon of sodium hypochlorite diluted with half a gallon of water) according to your local Health Codes and manufacturer's specifications.
- 2 - Pour the solution into the bowl(s).
- 3 - Using a brush suitable for the purpose, wipe the solution on all surfaces protruding above the solution-level and on the underside of the top cover(s).
- 4 - Install the top cover(s) and operate the unit. Allow the solution to agitate for about two minutes. Drain the solution out of the bowl(s).
- 5 - Use fresh product to chase any remaining sanitizer from the bottom of the bowl(s). Drain this solution. Do not rinse out the machine.

6 ROUTINE MAINTENANCE

- 1 - **Daily:** inspect the machine for signs of product leaks past seals and gaskets. If proper assembly does not stop leaks around seals or gaskets, check for improper lubrication, worn or damaged parts. Replace parts as needed.
- 2 - **Monthly on MT 1P, MT 2 and MT 3 models:** remove the dust from the condenser filter. A blocked filter will reduce



ATTENTION

Before any disassembly and/or cleaning procedure make sure that the dispenser is disconnected from its power source by unplugging it or switching off the 2-pole wall breaker.

performance and could cause compressor failure. Remove the only left panel (from faucet side) unscrewing

the two plastic coated screws (see figure 16).

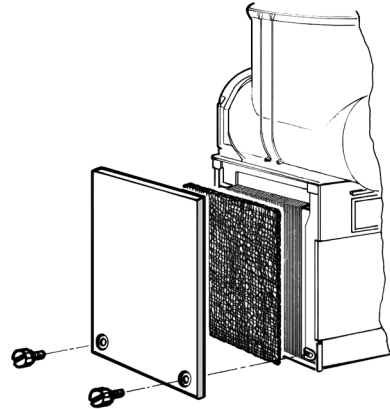

figure 16

- 3 - Replacement of lighted top cover bulb: remove the fixing screw placed in the upper part of the top cover, remove the lower part and replace the bulb (using a 24-28V 21W max bulb). Reassemble the top cover and replace the fixing screw.(see figure 17)

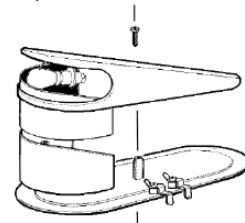

figure 17



ATTENTION

Condenser fins are very sharp. Use extreme caution when cleaning.

6. 1 MAINTENANCE (TO BE CARRIED OUT BY QUALIFIED SERVICE PERSONNEL ONLY)

- 1 - **Annually:** remove the panels and clean the inside of the machine including the base, side panels, condenser, etc.
- 2 - Never remove the insulating jacket from around the suction tubing of the evaporator (the copper tubing located on the right side of gear motor). In case the insulating jacket is missing replace the entire parts with original spare parts from the supplier.
- 3 - In order to prevent any damages to the dispenser, all plastics parts must be lubricated only with grease supplied by the manufacturer or with another lubricating product suitable for polycarbonate.



IMPORTANT

The electric diagram of the dispenser is located in the inner part of the dispensing side panel.

7 DEFROST TIMER (OPTIONAL)

The Defrost Timer, located on the right side of the unit,

automatically switches the dispenser from Granita mode to Soft Drink mode and the opposite. This means that during defrost periods frozen Granita will melt to thermostat setting temperature and once defrost period has expired, the product automatically freezes down again to Granita setting viscosity.

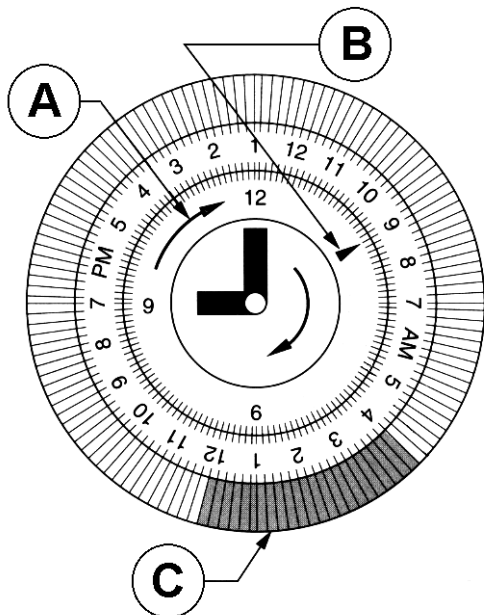

figure 18

To operate the defrost timer proceed as follows (see figure 18).

- 1 - Set the time of the day by rotating the dial clockwise (arrow A). **Never rotate the timer counterclockwise** as this would damage the internal mechanism. Align the current time of day with the arrow B on the timer face. This is a 24 hour timer showing both A.M. and P.M.
- 2 - Program the defrost timer by pushing out on the tabs C that correspond to the hours desired to defrost. Each tab represents 15 minutes. A minimum of four to eight hours are required to defrost frozen beverage (depending on ambient conditions).

Note: when all the tabs are pushed in the defrost function is OFF (the machine operates as if it were not equipped with Defrost Timer).

MT UL BLACK

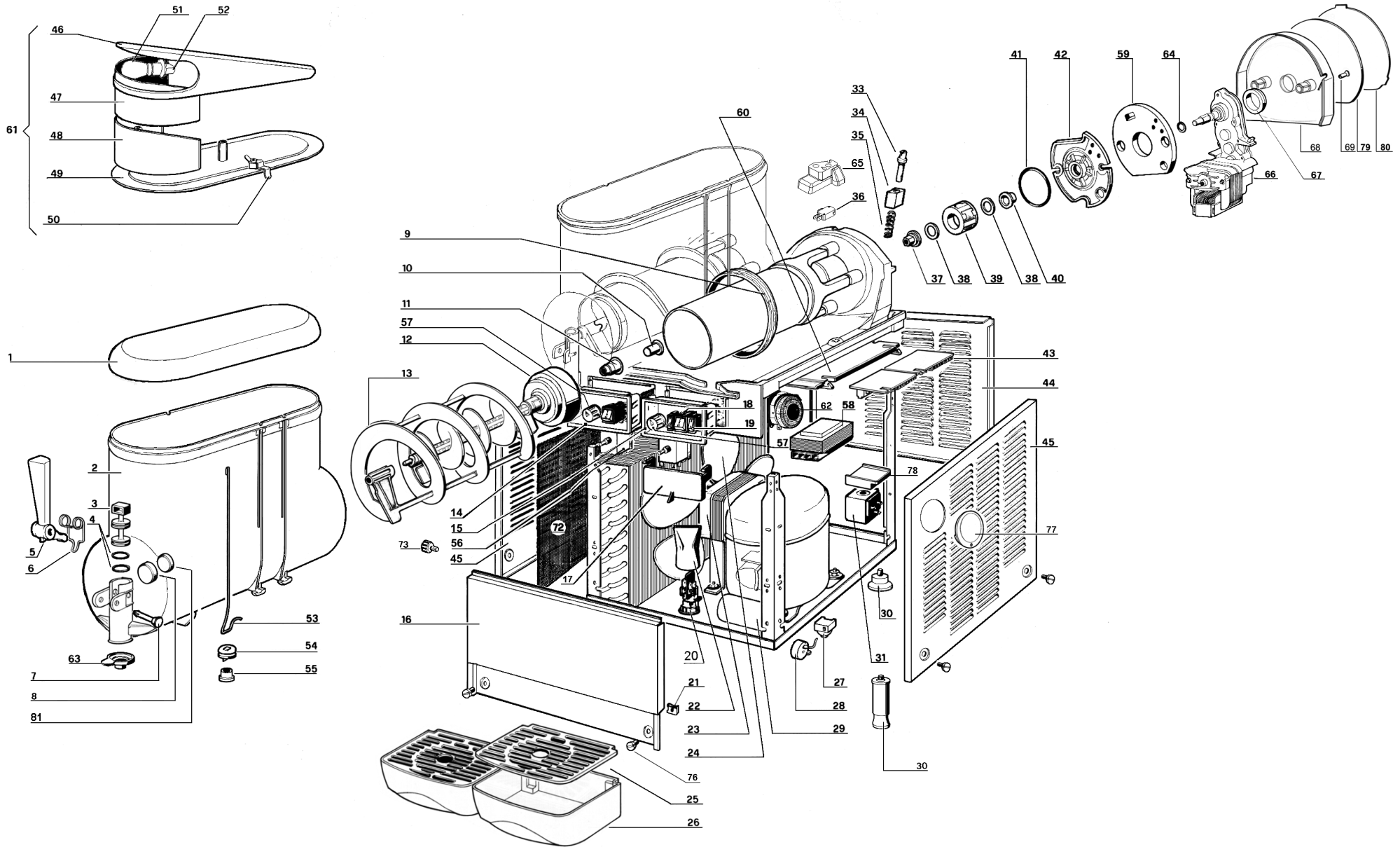

1	00263	Transparent cover	29	***	Starting-run capacitor	55	00177	Fixing ring
2	00638	Bowl	30	00158	Rubber leg	56	00132	Thermostat
3	00420	Faucet piston	30	00092	4" leg	57	00182	Thermostat knob
4	00101	Faucet piston OR	31	***	Solenoid valve coil	58	○○○	Transformer
5	00640	Black faucet handle	33	00087	Density adjustment screw	59	00231	Insulation foam
6	00447	Faucet handle spring	34	00720	Shaped nut	60	00449	PWB housing
7	00498	Black faucet handle pin	35	00088	Spring	61	00520	Lighted top cover (assy.)
8	00536	Thrust washer rubber cap	36	00121	Microswitch	62	00269	Timer switch
9	00653	Bowl gasket	37	00227	Rear wall rear bushing	63	00134	Restrictor cap
10	00126	Rear wall front bushing	38	00229	Magnetic drive washer	64	00255	Central shaft OR
11	00127	Auger bushing	39	00228	Magnetic drive	66	00704	Gear motor
12	00110	Black auger	40	00230	Flange bushing	67	00046	Rear bushing
13	00111	Outer spiral	41	00226	Flange OR 3231	68	00153	Black rear cover
14	00499	Black switch box	42	00183	Gear motor flange	69	00589	Black rear cover fixing screw
15	00500	Black power switch box	43	00448	Delay electronic device (PWB)	70	00517	Warning light
16	○○○	Dispensing side panel	44	○○○	Black back panel	73	00119	Black panel fixing screw
17	00504	Black switch box cover	45	00513	MT 1P-2-3 black side panel	76	00519	Stainless steel fixing screw for panel
18	00123	3-position switch	45	00514	MT 1P-2-3 black side panel for defrost timer	77	00532	Timer cover
19	00124	2-position switch	46	00515	Black lighted top cover (upper)	78	00463	Solenoid valve plastic cap
20	00265	Terminal block with cable clamp	47	00572	"Strawberry" graphic for top cover	79	00648	"All Fruit" graphic for rear cover
21	00179	Clip	47	00647	"All Fruit" graphic for top cover	79	00574	"Strawberry" graphic for rear cover
22	00297	Terminal block protection	48	00188	Picture screen	80	00575	Rear cover picture screen
23	○○○	Fan motor	49	00094	Lighted top cover (lower)	81	00537	Thrust washer
24	00133	Fan blade	50	00084	Top cover light contact			
25	○○○	Black drip tray cover	51	00100	28V bulb			
26	○○○	Black drip tray	52	00131	Bulb socket + bracket	○○○		See next table
27	***	Relay	53	00529	Light wire	***		Please order what printed on piece
28	***	Overload protector	54	00533	Flexible contact			

○○○
16
23
25
26
43
44
58

MT 2 UL
00502
00108
00588
00587
00113
00511
00193

MT 3 UL
00503
00108
00588
00587
00081
00512
00194

GEAR MOTOR SPARE PARTS LIST

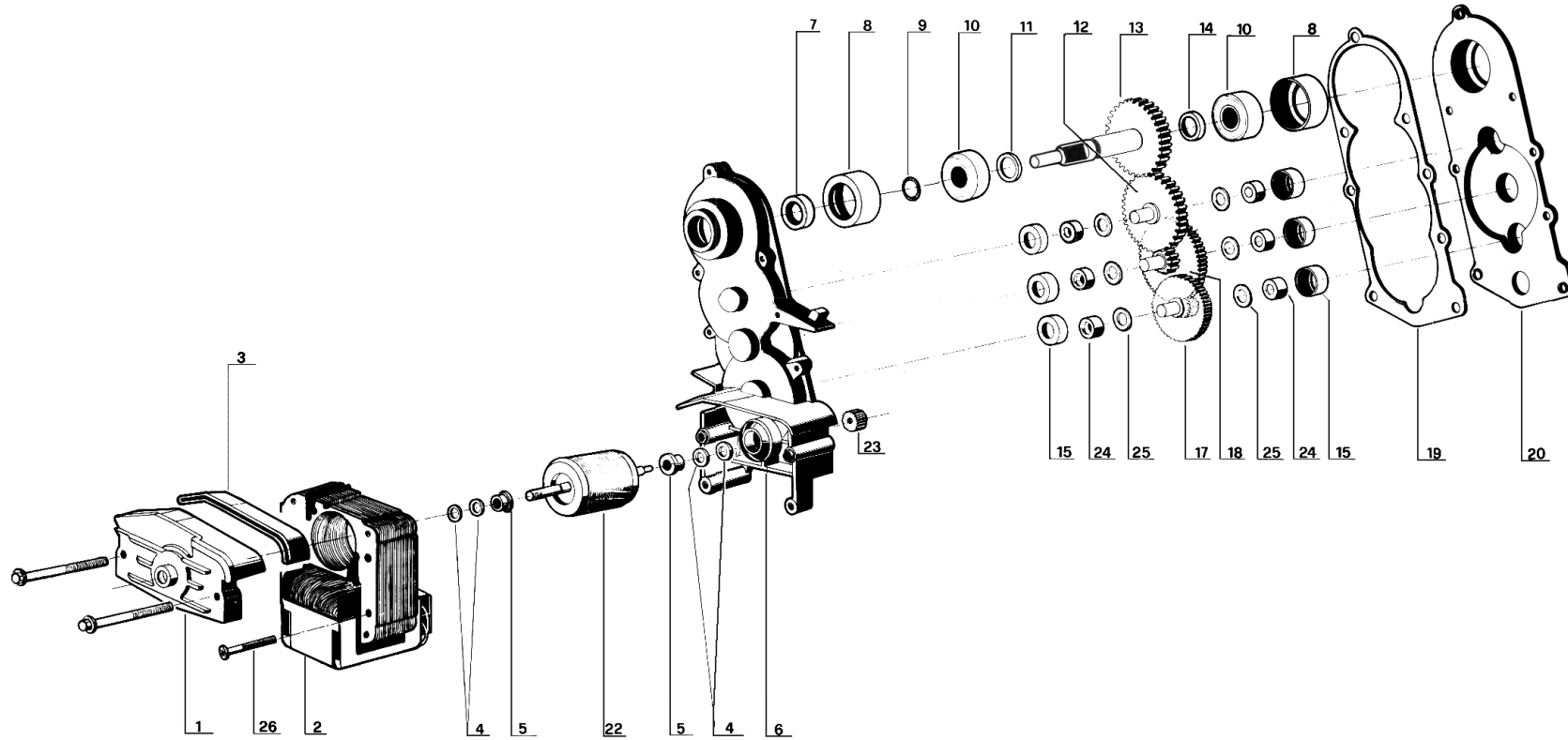

1	00097	Bracket with bush	10	00247	Ball bearing ý 28 mm	20	00721	Gear box cover
2	00156	Stator	11	00257	1.5 mm spacer	22	00180	Rotor
3	00296	Stator protection gasket	12	00184	Third gear	23	00187	Pinion
4	00168	Washer	13	00165	Fourth gear	24	00169	Bushing
5	00253	Rotor spacer	14	00258	3.3 mm spacer	25	00170	Washer
6	00190	Gear box with bushing	15	00224	Bushing rubber cap	26	00262	Bracket screw
7	00256	Seal retainer	17	00164	First gear			
8	00254	Ball bearing ý 28 mm rubber cap	18	00167	Second gear			
9	00255	Central shaft OR	19	00636	Gasket			



CECILWARE CORPORATION

43-05 20th Avenue
Long Island City, N.Y. 11105
Tel. (800) 935 2211
Fax (718) 932 7860
customer.service@cecilware.com
www.cecilware.com