

JAVA2-LP MANUAL



OPERATIONAL MANUAL

• Specifications.....	1
• Installation & Start Up Procedure.....	2 3
• Programming.....	3
• Adjustments.....	5
• Cleaning & Sanitizing.....	10
• Parts Identification.....	11
• Wiring Diagrams.....	

ELECTRICAL SPECIFICATIONS:

120 Volts
15 Amp Circuit
60 Hz
1 Heater
1,700 Watts
5-15R Receptacle

MECHANICAL SPECIFICATIONS:

Width: 8.5"
Depth: 20" + 2" Clearance For Waterline.
Height: 21" + 2.5" Legs.
Cup Clearance: 4.5"
Hopper Capacity: 1 Lb Dry Coffee.
Tank Capacity: 1 Us Gal.
Burst Rate: 120 Cups/Hr.
Recovery Time: 5 Min.

FACTORY SETTINGS:

Gram Throw Dial: 2.4
Coffee Gram Throw: 2.2 gr. Coffee /8 oz. Cup.
Water Flow Rate: 1 to 1.3 oz./sec.

Cecilware sells value...
Worldwide

43-05 20th Avenue, Long Island City, 11105 718-932-1414
Fax: 718-932-7860



INSTALLATION

Water Inlet Connection:

This equipment is to be installed to comply with the applicable Federal, State, or local plumbing codes having jurisdiction. In addition:

1. A quick disconnect water connection or enough extra coiled tubing (at least 2x the depth of the unit) so that the machine can be moved for cleaning underneath.
2. An approved back flow prevention device, such as a double check valve to be installed between the machine and the water supply.

The JAVA2-LP is equipped with a 1/4" Flare Water Inlet Fitting, located on the lower left side in the back of the base.

HIGHLY RECOMMENDED:

A WATER SHUT-OFF VALVE and A WATER FILTER, preferably a combination Charcoal/Phosphate Filter, to remove odors and inhibit lime and scale build up in the machine. Note: In areas with extremely hard water, a water softener must be installed in order to prevent a malfunctioning of the equipment and in order not to void the warranty.

STARTUP PROCEDURE

Caution: Make sure that the Heater Switch, located behind right hopper with door opened, is in the OFF position.

1. Connect the 1/4" dia copper waterline to the 1/4" flare water inlet fitting of the valve.
2. Plug the power cord into a proper receptacle.
3. Activate the **Power Switch** (Toggle Up). The door display panel and the green dispense buttons will light up and the tank will start filling. Allow approximately 2 minutes for the tank to fill.
4. Activate the **Heater Switch**. Allow approximately 15 - 20 minutes for the water to reach a preset temperature of 200°F. The heat up time will depend on the water inlet temperature, the input voltage and the wattage of the elements in the machine.
5. Place cup under nozzle and press dispense switch. The machine will dispense water at the rate of 1-1.3 oz. per second. Repeat it several times for each dispense switch to check for consistent output.
6. While the tank is heating up, remove the hoppers, load them with products and reposition them back in the machine. When the heater light goes OFF, the tank has reached its brew temperature and the machine is ready to dispense Coffee.

VOLUME AND DRINK SIZE ADJUSTMENTS:

PROGRAMMING INSTRUCTIONS FOR AUTOMATIC DISPENSE

1. Turn Power Switch ON (toggle switch inside door).
2. PRESS and HOLD [red] STOP Button with one hand.
3. PRESS and HOLD [green] DISPENSE Button with other hand.
4. RELEASE [red] STOP Button ONLY.
5. Continue to HOLD [green] DISPENSE Button for 5 SECONDS, then RELEASE.
6. PRESS and RELEASE [green] DISPENSE Button. Product begins dispensing.
When it reaches the "DESIRED VOLUME",
7. PRESS and RELEASE [green] DISPENSE Button to SET "DESIRED VOLUME".
DISPENSE Button can be "jogged" to top off.
8. PRESS and RELEASE [red] STOP button to LOCK IN "DESIRED VOLUME".
Repeat steps 1 to 8 for each Dispense Button.

PROGRAMMING INSTRUCTIONS FOR MANUAL DISPENSE

1. PRESS AND HOLD STOP [red] BUTTON WITH ONE HAND.
2. PRESS AND HOLD DISPENSE [green] BUTTON WITH OTHER HAND.
3. RELEASE STOP [red] BUTTON.
4. RELEASE DISPENSE [green] BUTTON.
5. PRESS AND RELEASE STOP [red] BUTTON.

The Total Time The Water Is Running Is Accumulated And Saved Into Memory. For Normal Operation, Press and Release Dispense Button.

The Automatic Dispense Buttons are factory programmed to dispense 8 oz. of Water per cup.

PRODUCT STRENGTH ADJUSTMENTS:

The JAVA units have **variable speed control auger motors [CD151]** with variable speed of 10 to 130 RPM].

Drink or Product Strength can be changed by adjusting the **Gram Throw Dial** on inside door panel.
The Gram Throw is factory preset at approx. 2.4 (2.2 gr. per 8 oz. cup) for the JAVA2-LP machines.
The water flow rate adjustment for the dispense valve should remain fixed bet. 1 - 1.3.

HOT WATER FLOW RATE ADJUSTMENTS:

Note: Remove right side panel to access the Water Dispense Valves, .

TO ADJUST HOT WATER FLOW RATE:

1. Remove right side panel to access the Water Dispense Valves, mounted on tank.
2. Locate adjustment screw on Dispense Valve.
3. Using Allen Key or flat screwdriver rotate, 1/4 turn at a time,
CLOCKWISE to decrease water flow, or COUNTERCLOCKWISE to increase water flow.
4. Check water flow output, after each 1/4 turn.

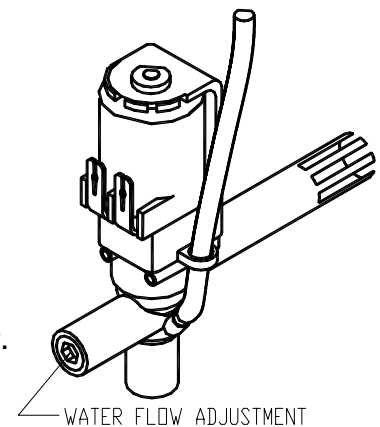

JAVA2-LP HOPPER ASS'Y CD313 & DISPENSE ASS'Y

CAPACITY- 1 LB COFFEE, 7.875"H w/cover x 3"W, W/NYLON AUGER

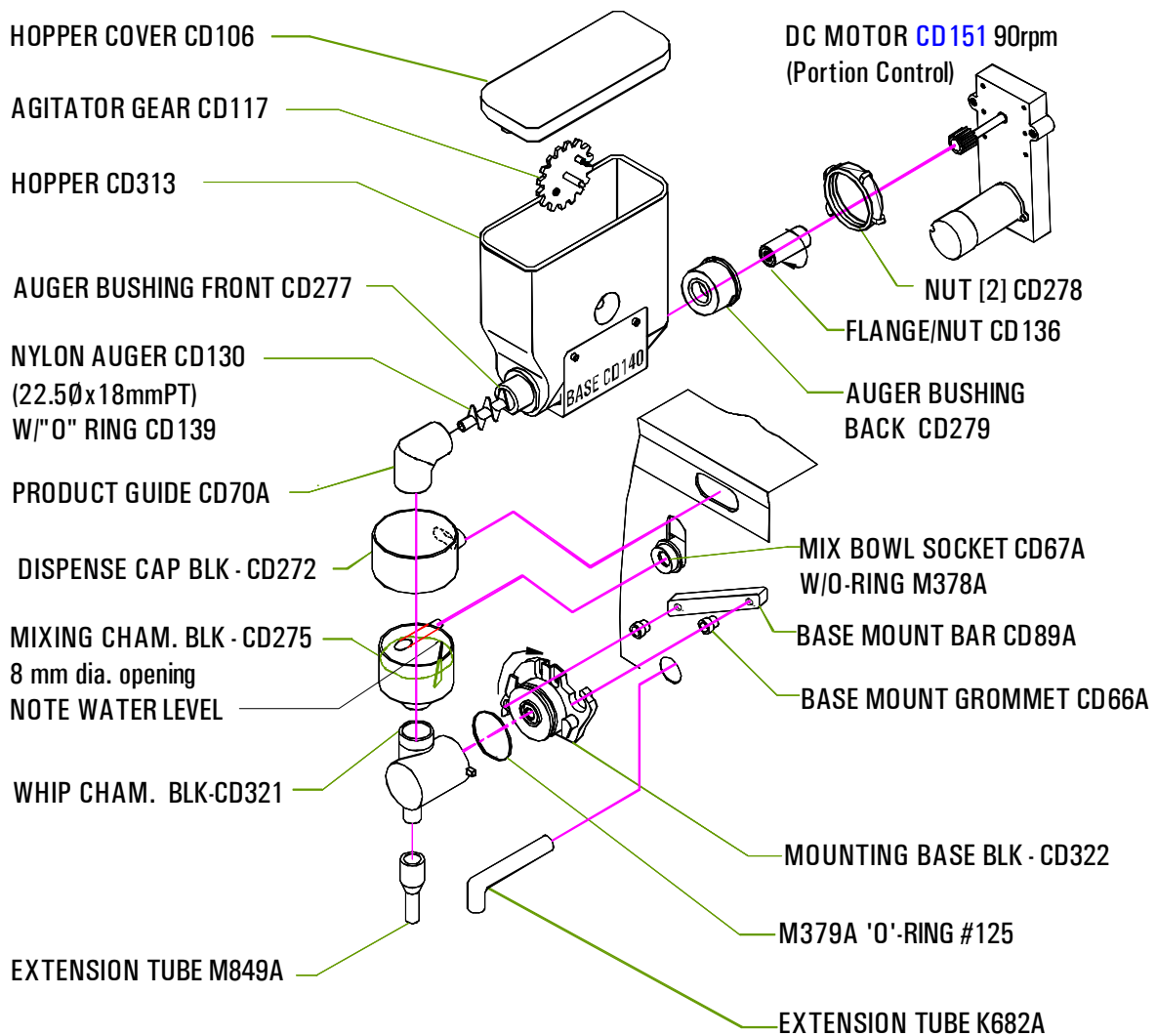

CLEANING AND SANITIZING:

SANITIZING: All food dispensing units should be sanitized periodically. All parts to be sanitized must be cleaned first. To prepare a sanitizing solution: ADD 2 TSP. OF LIQUID CLOROX BLEACH (5.25% CONCENTRATION) TO 1 GALLON OF WATER AT ROOM TEMPERATURE (70° - 90°F).

Soak all parts for a minimum of 3 min. in the sanitizing solution. Note: Always start with a unopened bottle of Clorox Bleach since the solution from an opened bottle has a short life span.

Let all sanitized parts drain and dry naturally. DO NOT WIPE THEM DRY. Before using the sanitized unit (or parts) with food stuffs, rinse all parts thoroughly with water.

CARE FOR STAINLESS STEEL:

Stainless Steel surfaces that come in contact with food substances, MUST BE CLEANED EVERY DAY.

WHEN CLEANING STAINLESS STEEL, ONLY A pH NEUTRAL CLEANER IS TO BE USED.

Use nylon or brass brushes (not steel wire brushes) for removing food deposit.

Many food products contain acids,alkalies, or other substances which corrode Stainless Steel.

RECOMMENDED DAILY CLEANING AND MAINTENANCE

1. Empty drip tray and wash with dish detergent.
2. Rinse Chamber:
3. Flip RINSE SWITCH ON and press DISPENSE BUTTON.
4. Flip RINSE SWITCH OFF. Remove and refill Hopper.
5. Turn PRODUCT GUIDE UP to reduce spillage.

CLEAN HOPPER (once a week)

- a. Open cabinet door and top lid.
- b. Turn the product guide up, to reduce spillage.
- c. Empty out Hopper.
- d. Pull off Product Guide.
- e. Unscrew Agitator and remove.
- f. Remove the auger by turning the hopper horizontal, auger will fall out.
- g. Wash parts with dish detergent.
- h. Rinse, dry, and re-assenble parts.

CLEAN DISPENSE CHAMBER (once a week)

1. Twist CW and pull off STEAM DEFLECTOR.
2. Pull off DISPENSE CHAMBER.
6. Wash components with dish detergent.
7. Rinse, dry, and re-assenble parts.



FRONT OPEN VIEW

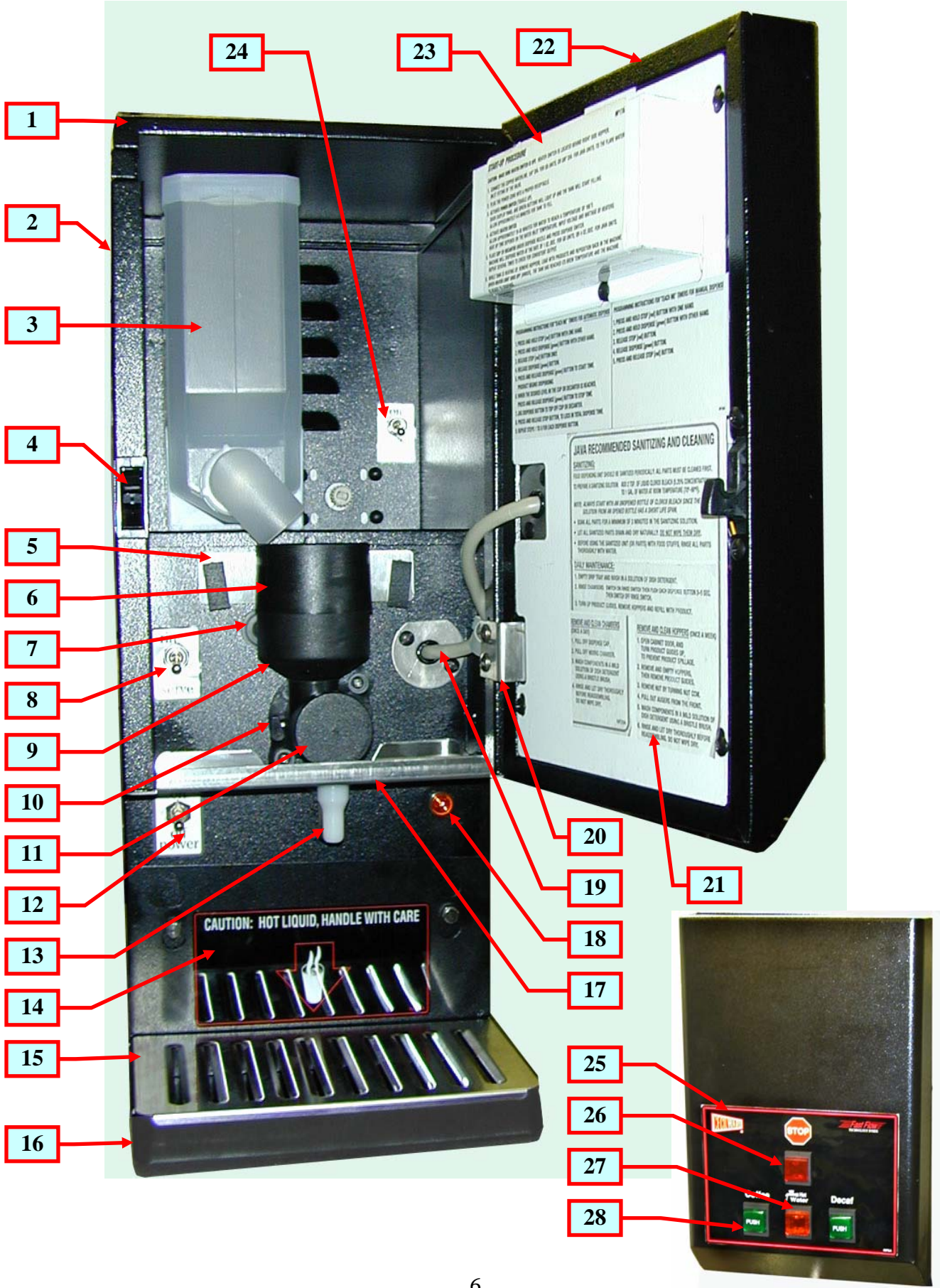

RIGHT SIDE OPEN VIEW

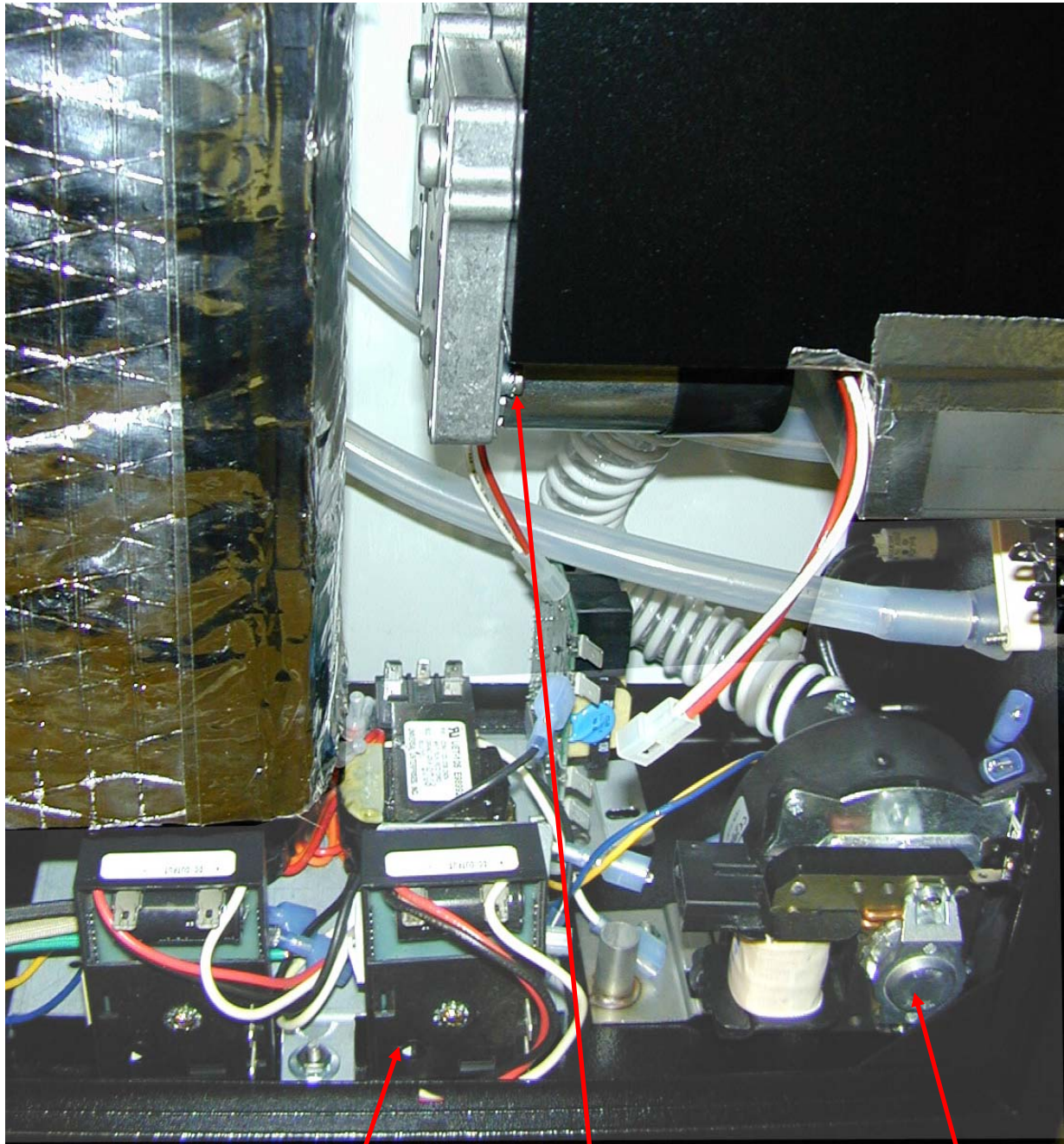

1

2

3

LEFT SIDE OPEN VIEW

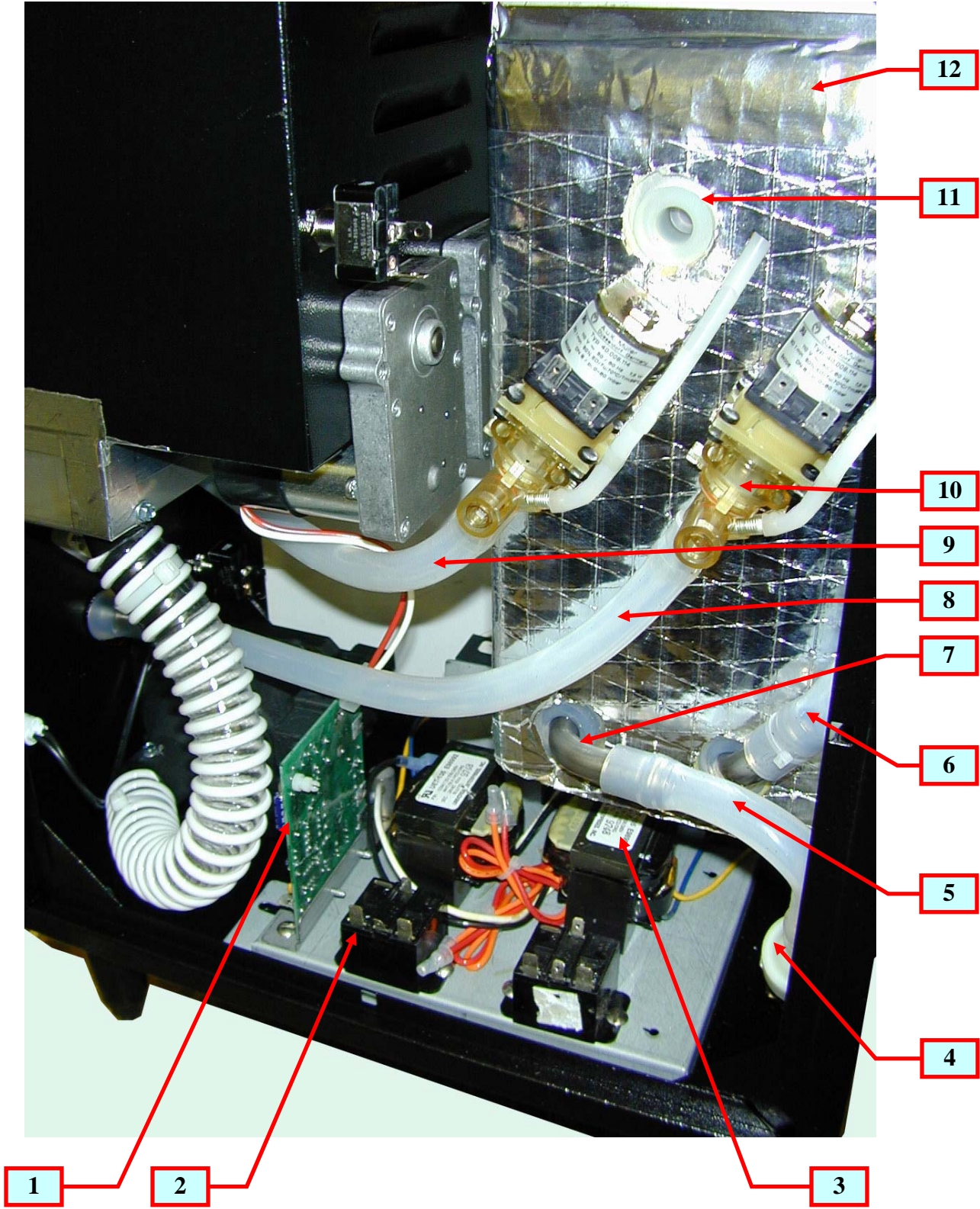

TANK TOP ASS'Y

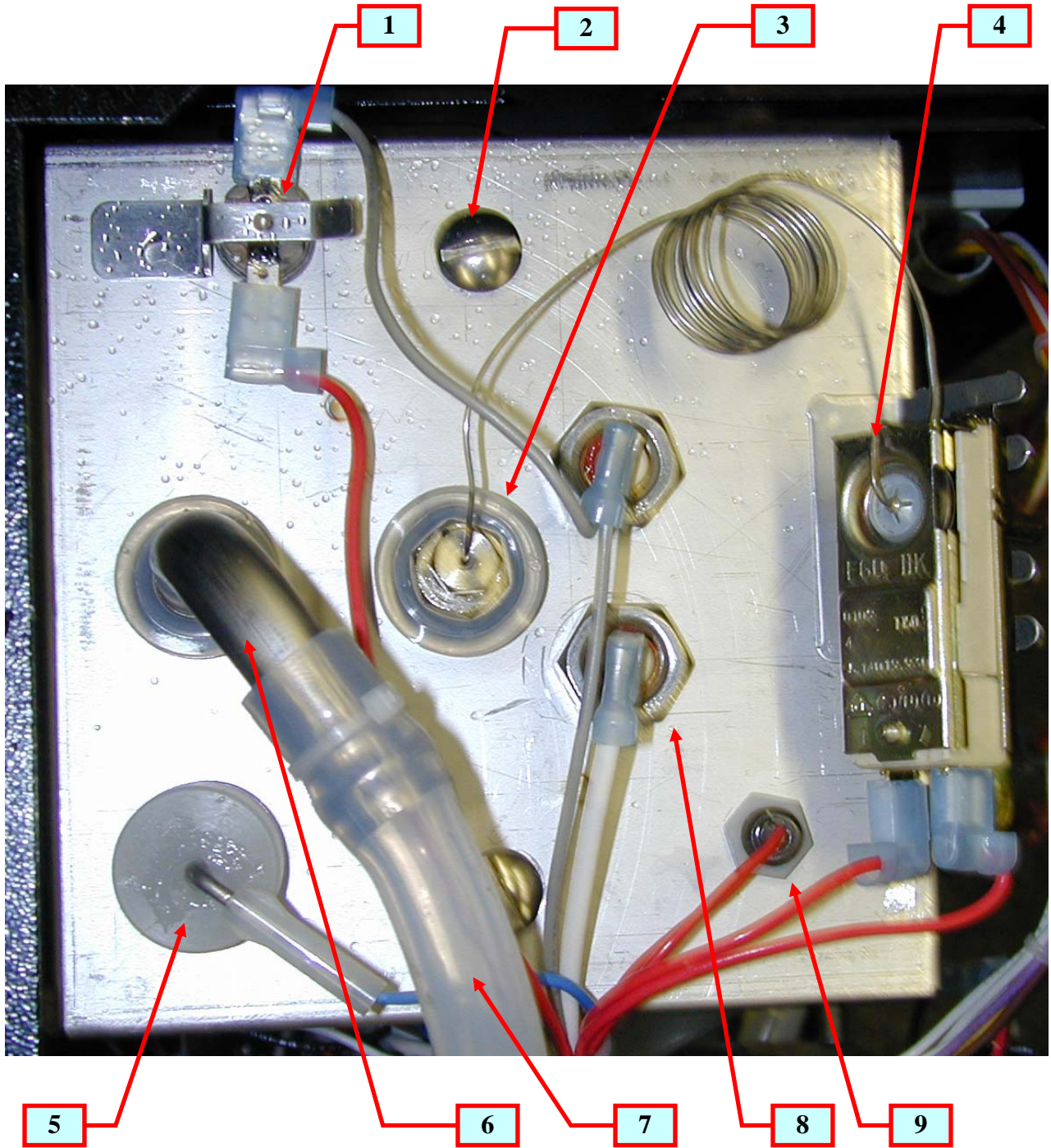

FRONT OPEN VIEW			
ITEM	P/N	QTY	DESCRIPTION
1	RX67A	1	TOP COVER, CABINET
2	SF79A	2	SIDE PANELS
3	CD313	1	HOPPER ASS'Y
4	M705A	1	DOOR LATCH
5	RV57Q	1	TROUGHT DRAWER ASS'Y
6	CD272	1	STEAM DEFLECTOR
7	CD67A	1	SOCKET F/ MIXING BOWL
8	L299A	1	RINSE SWITCH
9	CD275	1	DISPENSE CHAMBER [8mm dia.]
10	CD321	1	WHIPPER CHAMBER
11	CD322	1	BASE MOUNT CLOSED F/ WHIP. CHAMBER
	M848A	1	PLUG F/ BASE MOUNT
	CD66A	2	GROMMETS
	CD89A	1	MOUNTING BAR
12	L069A	1	POWER SWITCH
13	M849A	1	COFFEE SPOUT, WHITE TEFLON 1.75" L
	K682A	1	HOT WATER SPOUT [1.5"L X 4"L]
14	NA91A	1	CAUTION LABEL
15	SF84A	1	GRILL
16	SF83A	1	TRAY
17	SF23A	1	FACIA BOTTOM CAP
18	C002A	1	HEATER LIGHT
19	CH93A	1	DOOR HARNESS
20	K618A	1	HIDDEN HINGES [1 SET]
21	NF17A	1	START UP PROCEDURE INSIDE DOOR
	NF58A	1	PROGRAMMING INSTRUCTIONS
	N978A	1	CLEANING AND SANITIZING INSTRUCTIONS
22	SF19Q	1	DOOR FRAME ASS'Y
23	SF21A	1	INSIDE DOOR PANEL
	SF22A	1	KNOBS COVER
	L576A	3	TEACH ME TIMERS
	L557A	2	POTENTIOMETERS
24	L567A	1	HEATER SWITCH
25	Ni70A	1	SWITCH PANEL LABEL
26	L574A	1	STOP SWITCH RED
27	L457A	1	HOT WATER SWITCH AMBER
28	L455A	2	DISPENSE SWITCH GREEN

RIGHT SIDE OPEN VIEW			
ITEM	P/N	QTY	DESCRIPTION
1	L556A	2	SPEED CONTROL BOARD F/AUGER MOTOR
2	CD151	2	AUGER MOTOR
3	CD56A	1	BLOWER

LEFT SIDE OPEN VIEW			
ITEM	P/N	QTY	DESCRIPTION
1	L566A	1	LEVEL CONTROL BOARD
2	B129A	2	RELAYS, SAFETY
3	CF29A	2	TRANSFORMERS
4	CD257	1	WATER INLET VALVE
5	M830A	1	HOSE - inlet valve to tank .375 Id x 9"L
6	M829A	1	HOSE - drain .375 IDx12"L
7	K525A	1	ELBOW
8	M832A	1	HOSE - Disp. Valve, Nozzle .375 Id x 11"L
9	M831A	1	HOSE - Disp. Valve-Chamber .375 Id x3.5"L
10	L467A	2	DISPENSE VALVE [1-Product, 1-Hot Water]
11	M494A	1	GROMMET PLUG [F/ TESTING]
	M461A	6	GROMMET [0.466 DIA]
12	SG06Q	1	TANK BODY ASS'Y
	M600A	1	SPLICED GASKET, CUT FROM 21.75" TO 21"

TANK TOP ASS'Y SG08A			
ITEM	P/N	QTY	DESCRIPTION
1	L573A	1	HI-LIMIT, SURFACE MOUNT
2	P465A	2	SCREW, TANK TOP 1/4-20x5/8
3	M461A	6	GROMMET [.446 ID]
4	L681A	1	THERMOSTAT
5	K402Q	1	LEVEL CONTROL PROBE
6	K525A M787A	6	ELBOW TUBE, SS OR ELBOW SILICON TUBE, BREATHER
7	M	1	HOSE, BREATHER TUBE
8	G296A 03051 07059 M730A	1 2 2 2	HEATER 120V, 1500W NUT F/ HEATER WASHER F/ HEATER OUTSIDE WASHER F/ HEATER INSIDE
9	L499A	1	FLOAT SWICH

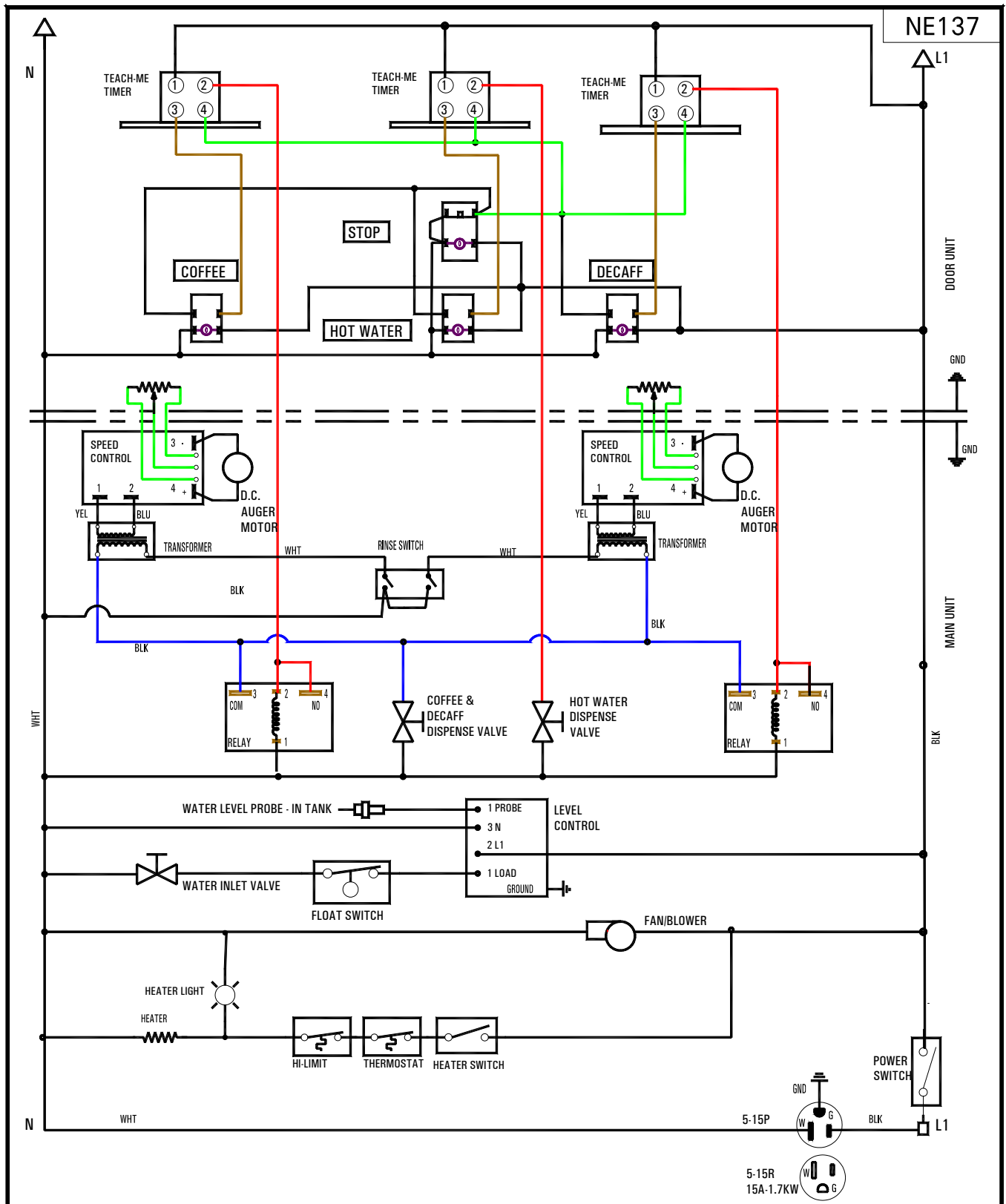

REV	BY	DATE	DESCRIPTION	APP'D BY	DATE	PART NO	NE137
				DRAWN BY	CG	DATE	3/27/2001
				SCALE	1 : 1		
CECILWARE CORPORATION				43-05 20 AVE. L.I.C. NY 11105			
TITLE: ELECTRICAL DIAGRAM (JAVA-2-LP W/ TEACH ME TIMERS)							REV.

NE137