

QUICK BREW DISPENSERS FOR DECANTER/ CUP



JAVA 2 QB-D3

MODELS:

- * JAVA 2 QB-D
- * JAVA 2 QB-D1
- * JAVA 2 QB-D2
- * JAVA 2 QB-D3
- * JAVA 2 QB-DC



Since 1911

Cecilware Corporation

43-05 20th. Avenue, LIC NY 11105
Tel: 800.935.2211 / 718.932.1414
Fax: 718.932.7860 • www.cecilware.com
Email: customer.service@cecilware.com

Cecilware sells value... Worldwide

Operation Manual
NL86A SEP 2010

To purchase spare parts, please go to www.cecilwarepartsdirect.com

QUICK BREW DISPENSER DECANTER/ CUP

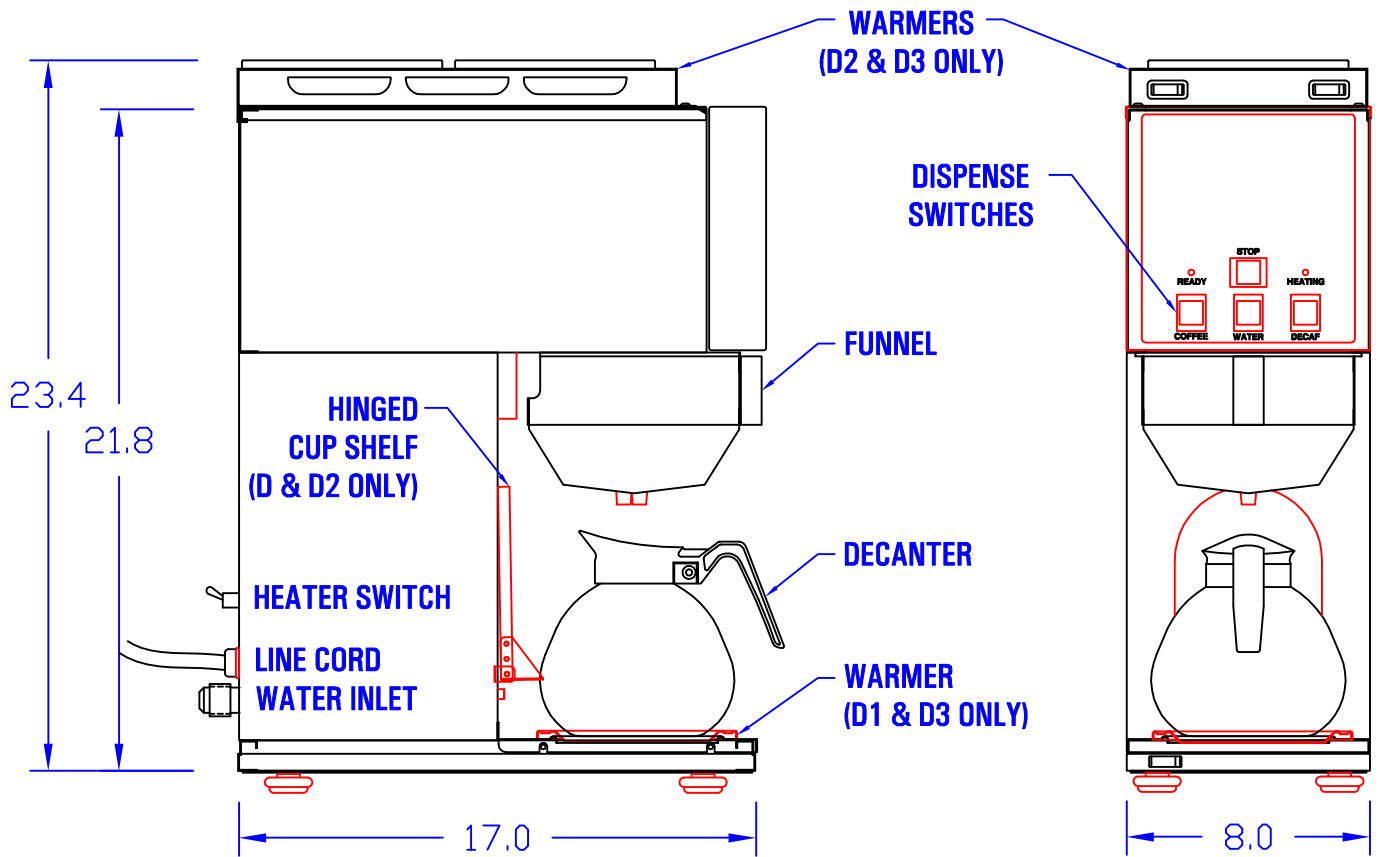

SPECIFICATIONS

MODEL #	DISPENSE	# OF WARMERS	HOPPERS	WATER TANK
JAVA 2 QB-D 120V OR 240V	USA - SINGLE BOWL	0	2 (14 OZ.)	1.0 GAL
JAVA 2 QB-D1 120V OR 240V	USA - SINGLE BOWL	1	2 (14 OZ.)	1.0 GAL
JAVA 2 QB-D2 120V OR 240V	USA - SINGLE BOWL	2	2 (14 OZ.)	1.0 GAL
JAVA 2 QB-D3 120V OR 240V	USA - SINGLE BOWL	3	2 (14 OZ.)	1.0 GAL

ELECTRIC: 120 V 50-60 HZ , 1.7 KW 15 A, Nema 5-15P Line Cord
240 V 50-60 HZ , 3.8 KW 20 A, Nema 6-20P Line Cord

PLUMBING: Water line required, dispenser supplied with 1/4 inch male flare fitting.

CECILWARE CORPORATION 43-05 20 AVE. L.I.C. NY 11105

QUICK BREW DISPENSER DECANTER/ CUP

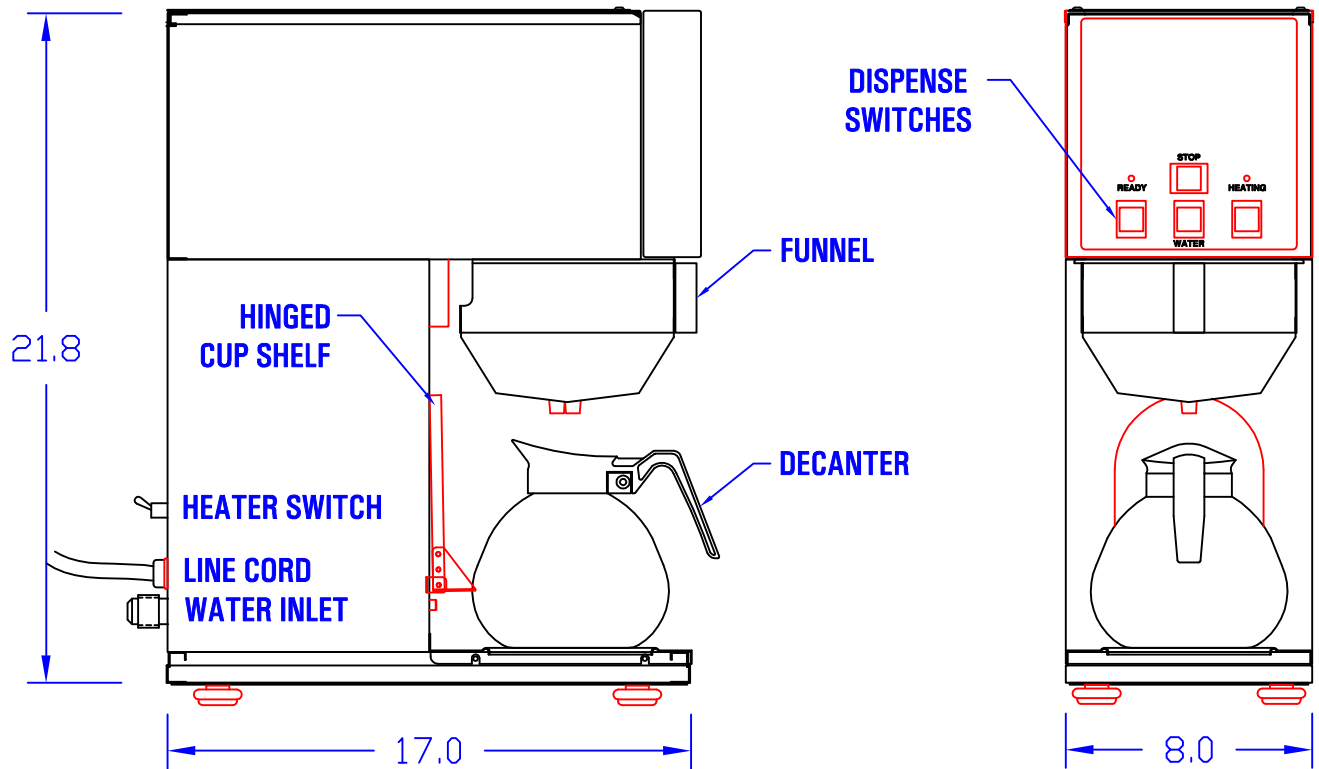

SPECIFICATIONS

MODEL #	DISPENSE	# OF WARMERS	HOPPERS	WATER TANK
JAVA 2 QB-DC 120V	CANADA - DUAL BOWL	0	2 (14 OZ.)	1.0 GAL
JAVA 2 QB-DC 240V	CANADA - DUAL BOWL	0	2 (14 OZ.)	1.0 GAL

ELECTRIC: 120 V 50-60 HZ , 1.5 KW 15 A, Nema 5-15P Line Cord
 240 V 50-60 HZ , 3.5 KW 20 A, Nema 6-20P Line Cord

PLUMBING: Water line required, dispenser supplied with 1/4 inch male flare fitting.

CECILWARE CORPORATION 43-05 20 AVE. L.I.C. NY 11105

INSTALLATION

Water Inlet Connection:

This equipment is to be installed to comply with the applicable Federal, State, or local plumbing codes having jurisdiction. In addition:

1. A quick disconnect water connection or enough extra coiled tubing (at least 2 times the depth of the unit) so that the machine can be moved for cleaning underneath.
2. An approved back flow prevention device, such as a double check valve to be installed between the machine and the water supply.

The JAVA2-QB-D is equipped with a **1/4"** Flare Water Inlet Fitting, located behind the unit near the bottom.

HIGHLY RECOMMENDED:

A WATER SHUT-OFF VALVE and A WATER FILTER, preferably a combination Charcoal/Phosphate Filter, to remove odors and inhibit lime and scale build up in the machine. Note: In areas with extremely hard water, a water softener must be installed in order to prevent a malfunctioning of the equipment and in order not to void the warranty.

STARTUP PROCEDURE

Caution: Make sure that the Heater Switch, located behind unit near the bottom, is in the OFF (toggle down) position.

1. Connect the **1/4" Dia.** copper waterline to the **1/4" flare** water inlet fitting of the valve.
2. Connect the power cord into a proper receptacle.
3. Activate the **Power Switch** (Toggle Up). The tank will start filling. Allow approximately **5** minutes for the tank to fill.
4. Activate the **Heater Switch**. Allow approximately **20-45** minutes for the water to reach a preset temperature of 200°F. The heat up time will depend on the water inlet temperature, the input voltage, and the wattage of the elements in the machine.
5. Place cup under nozzle and press dispense switch, button will light while dispensing. The machine will dispense water at the rate of **1.3** oz. per second.
Repeat it several times for each dispense switch to check for consistent output.
6. While the tank is heating up, remove the hoppers, load them with products and reposition them back in the machine.

NOTE: Decanter capacity is up to 54 OZ. Cup capacity is up to 12 OZ.

PROGRAMMING FOR AUTOMATIC DISPENSE

(See Door diagram)

1. Turn Power Switch ON (toggle switch inside door).
2. PRESS and HOLD [red] STOP Button with one hand.
3. PRESS and HOLD [green] DISPENSE Button with other hand.
4. RELEASE [red] STOP Button ONLY.
5. Continue to HOLD [green] DISPENSE Button until BUZZER sounds, then RELEASE.
6. PRESS and RELEASE [green] DISPENSE Button.
Product begins dispensing.
When it reaches the "DESIRED VOLUME",
7. PRESS and RELEASE [green] DISPENSE Button to SET "DESIRED VOLUME".
DISPENSE Button can be jogged to top off.
8. PRESS and HOLD [red] STOP Button for 5 Secs. to LOCK IN "DESIRED VOLUME".
Repeat steps 1 to 8 for each Dispense Button.

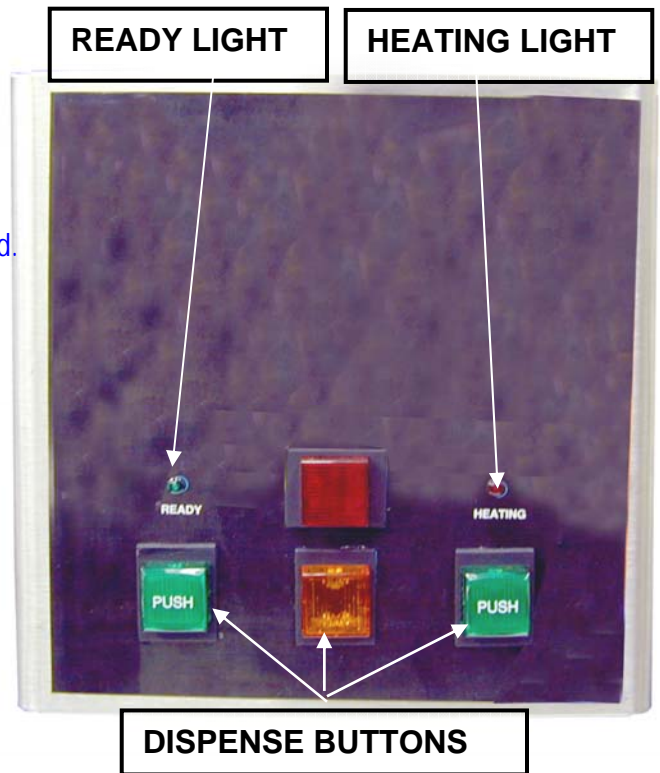

The Automatic Dispense Buttons are factory programmed to dispense 1.3 oz. of water per second.

NOTE:

Set programming for Cup Volume with cup shelf "DOWN".
Set programming for Decanter Volume with cup shelf "UP".

PRODUCT STRENGTH ADJUSTMENTS:

The JAVA 2-QBD units have **variable speed control auger motors** with variable speed of 10 to 30 RPM.

Drink or Product Strength can be changed by adjusting the **Gram Throw Dial** on inside door panel.

The Gram Throw is factory preset at approx. 2.2 gr. per 8 oz. cup and 15.0 gr. per decanter.

The water flow rate adjustment for the dispense valve should remain fixed at 1.3 oz per sec.



CLEANING AND SANITIZING:

SANITIZING: All food dispensing units should be sanitized periodically. All parts to be sanitized must be cleaned first. To prepare a sanitizing solution: ADD 2 TSP. OF LIQUID CLOROX BLEACH (5.25% CONCENTRATION) TO 1 GALLON OF WATER AT ROOM TEMPERATURE (70°F - 90°F).

Soak all parts for a minimum of 3 min. in the sanitizing solution. Note: Always start with an unopened bottle of Clorox Bleach since the solution from an opened bottle has a short life span.

Let all sanitized parts drain and dry naturally. DO NOT WIPE THEM DRY. Before using the sanitized unit (or parts) with foodstuffs, rinse all parts thoroughly with water.

CARE FOR STAINLESS STEEL:

STAINLESS STEEL surfaces, that comes in contact with food substances, MUST BE CLEANED EVERY DAY. WHEN CLEANING STAINLESS STEEL, ONLY A PH NEUTRAL CLEANER IS TO BE USED. Use nylon or brass brushes (not steel wire brushes) for removing food deposit. Many food products contain acids, alkalis, or other substances, which corrode Stainless Steel.

RECOMMENDED DAILY CLEANING AND MAINTENANCE

1. Wash cup shelf and warmer dish with dish detergent.

Rinse Chambers:

Flip Toggle SWITCH to RINSE position and press DISPENSE BUTTON.

When done, flip toggle switch back to SERVE position.

Remove and refill Hoppers.

Note: When removing hoppers, turn PRODUCT GUIDE UP to reduce spillage, return to down position after re-inserting hoppers.

CLEAN HOPPERS (once a week)

1. Turn the product guide up, and remove hoppers.
2. Empty out Hoppers.
3. Pull off Product Guide.
4. Wash parts with dish detergent.
5. Rinse, dry, and re-assemble parts.

CLEAN DISPENSE CHAMBERS (once a week)

1. Twist CW and pull off STEAM DEFLECTOR.
2. Pull off DISPENSE CHAMBER.
3. Wash components with dish detergent.
4. Rinse, dry, and re-assemble parts.

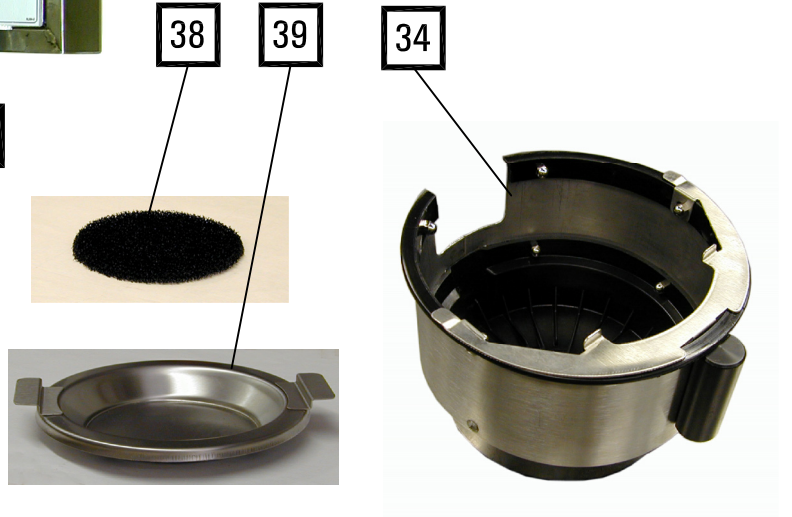
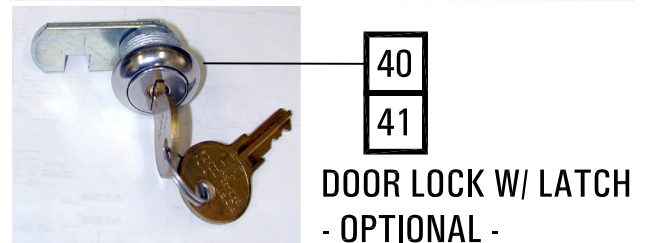
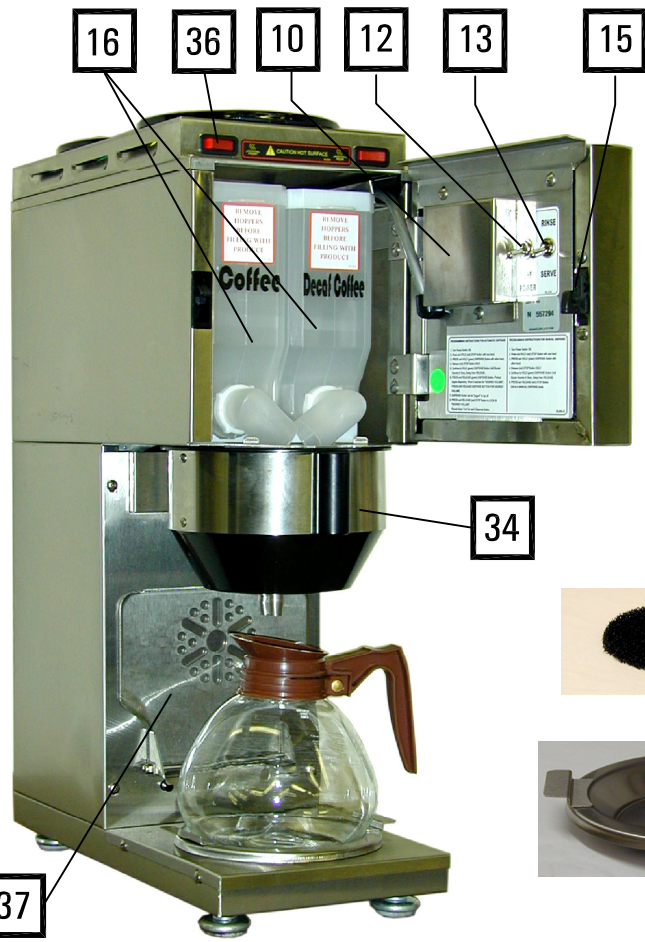
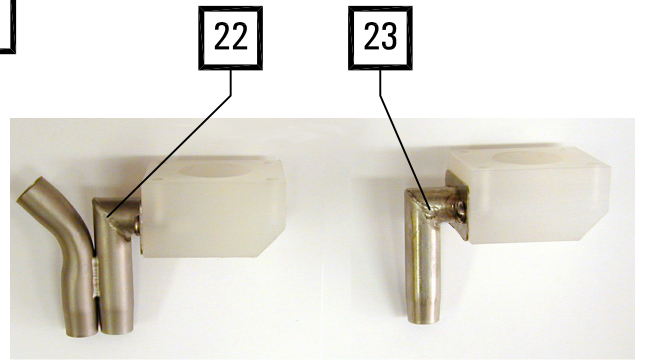
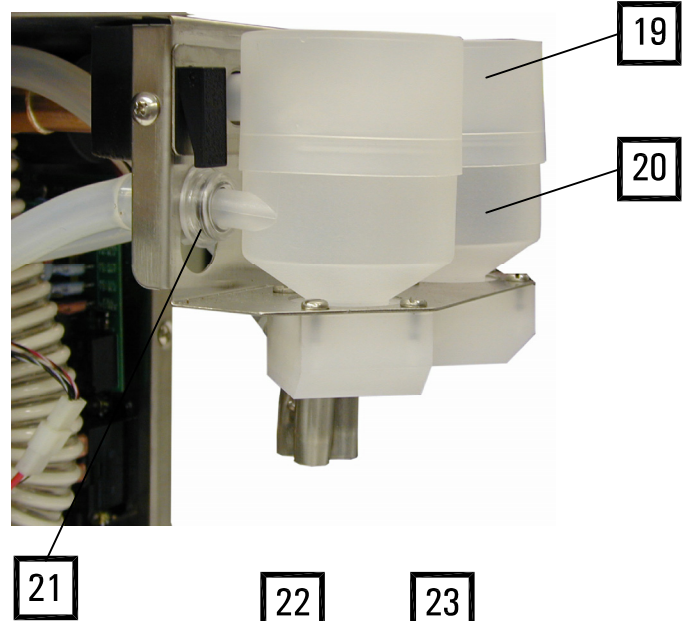
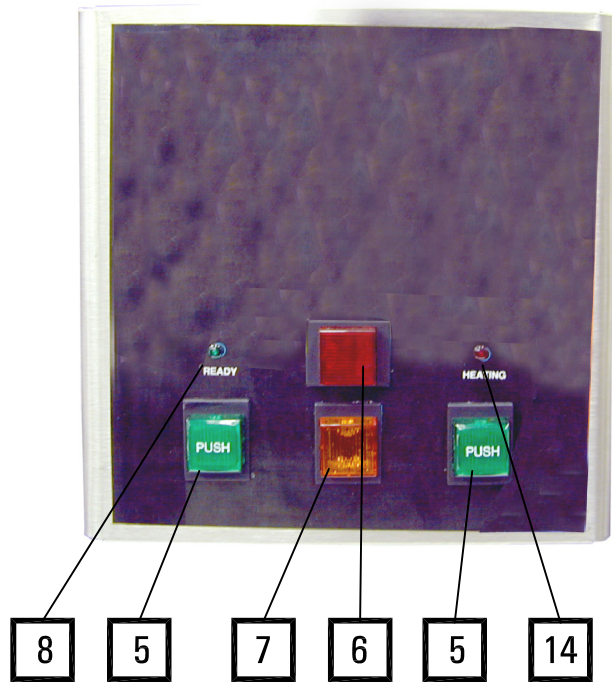

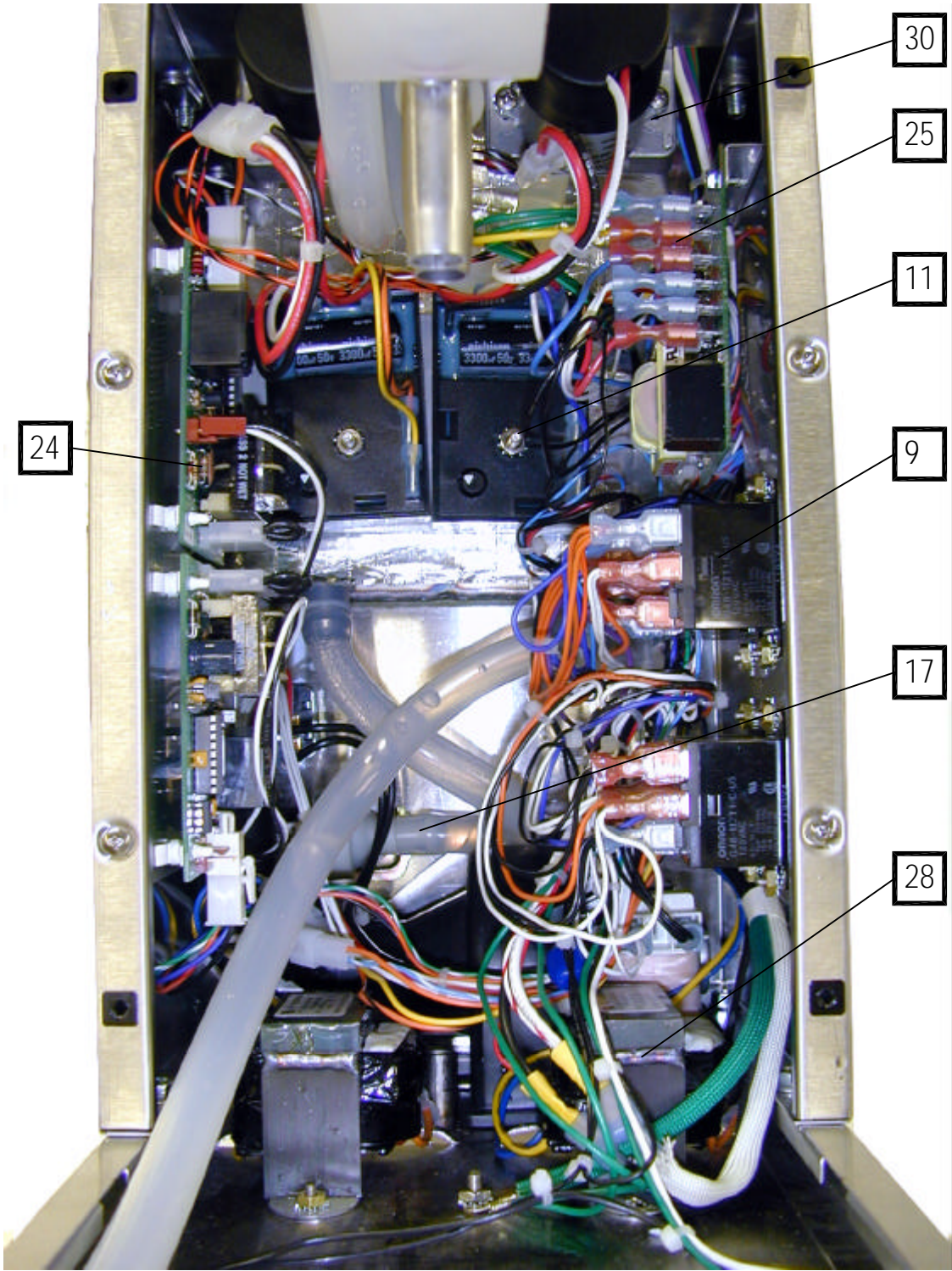

WATER TANK ASSEMBLY

CAPACITY = 1 GALLON

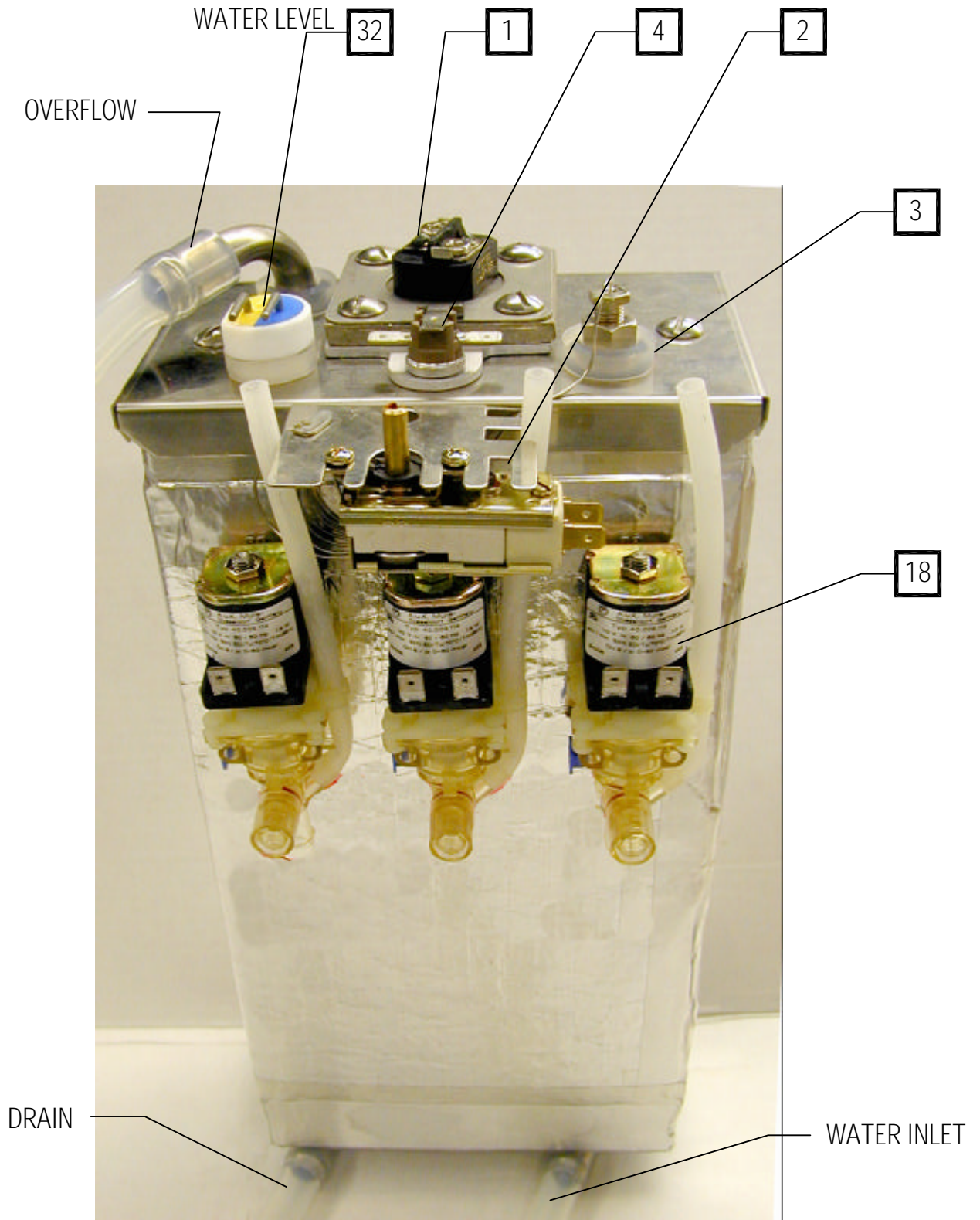

DECAF HOPPER CD325

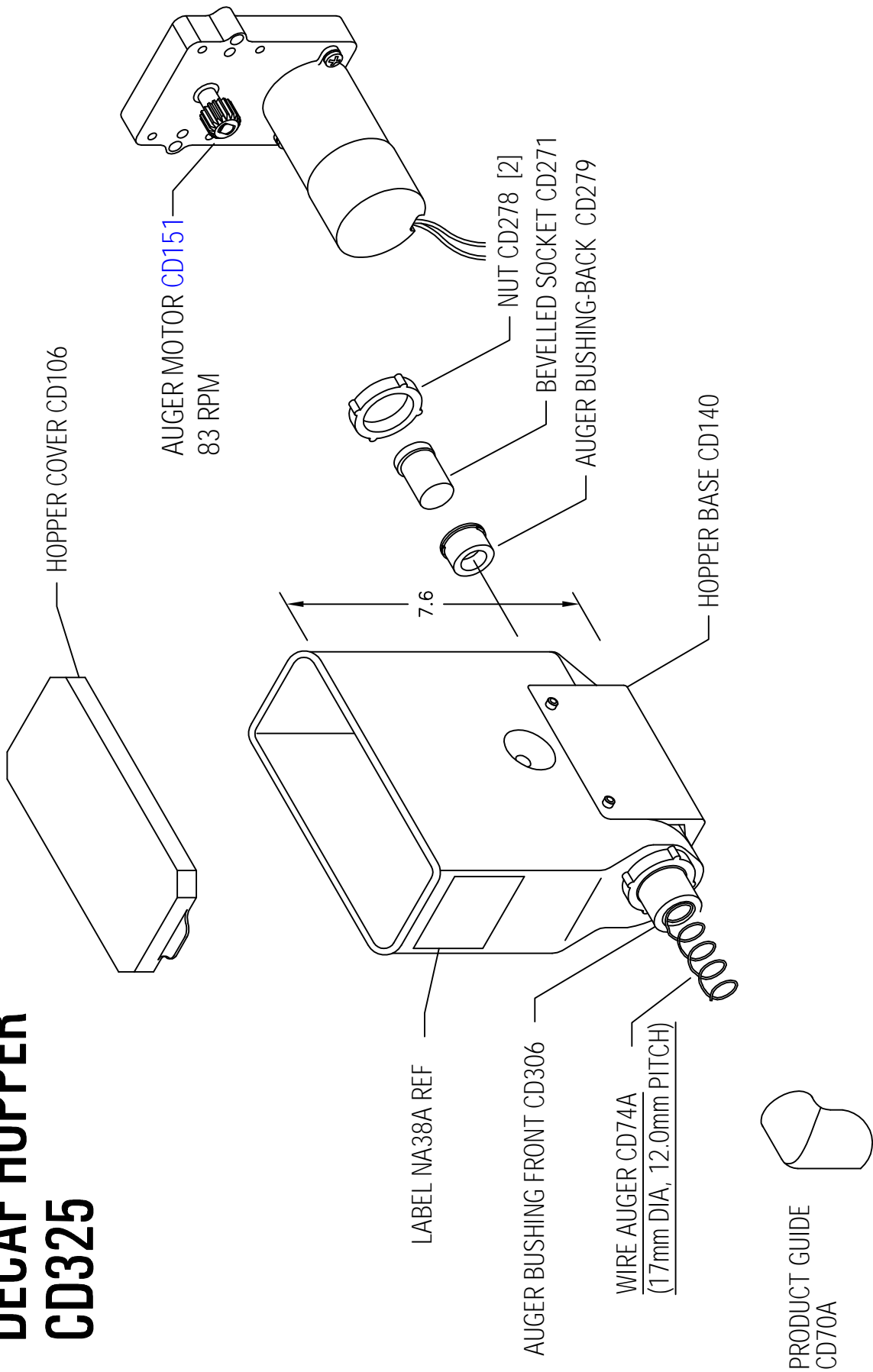

PARTS LIST : JAVA 2-QB-D, -D1, -D2, -D3, -DC

ITEM	DESCRIPTION	PART NO	-D	-D1	-D2	-D3	-DC
1	HEATER, 1500W, 120V	G194A	1	1	1	1	1
1	HEATER, 3500W, 240V	G197A	1	1	1	1	1
2	THERMOSTAT	L681A	1	1	1	1	1
3	SILICONE GROMMET, 12 mm	M461A	7	7	7	7	8
4	HI-LIMIT, 200° CUTOUT	L656A	1	1	1	1	1
5	PUSH BUTTON SWITCH (GREEN DISPENSE)	L455A	2	2	2	2	2
6	PUSH BUTTON SWITCH (RED STOP)	L574A	1	1	1	1	1
7	PUSH BUTTON SWITCH (AMBER HOT WATER)	L457A	1	1	1	1	1
8	PILOT LIGHT, GREEN (READY) 120V	CH112	1	1	1	1	1
8	PILOT LIGHT, GREEN (READY) 240V	CH260	1	1	1	1	1
9	RELAY, 120V	B138A	4	4	4	4	3
9	RELAY, 220V (FOR 240 V UNITS)	B172A	4	4	4	4	3
10	POTENTIOMETER	L557A	2	2	2	2	2
11	SPEED CONTROLLER	L556A	2	2	2	2	2
12	TOGGLE SWITCH, DPST (POWER ON-OFF)	L299A	1	1	1	1	1
13	TOGGLE SWITCH, SPST (RINSE-SERVE) & (HEATER)	L069A	2	2	2	2	2
14	PILOT LIGHT, RED (HEATING) 120V	32004	1	1	1	1	1
14	PILOT LIGHT, RED (HEATING) 240V	CD55A	1	1	1	1	1
15	LATCH	M705A	1	1	1	1	1
16	HOPPER	CD325	2	2	2	2	2
17	WATER INLET VALVE 110V	CD257	1	1	1	1	1
17	WATER INLET VALVE 220V	CD258	1	1	1	1	1
18	DISPENSE VALVE	L467A	2	2	2	2	3
18	240 VOLT COIL F/DISPENSE VALVE	CF38A	2	2	2	2	3
19	STEAM CAP	CD272	1	1	1	1	2
20	MIXING BOWL	CD275	1	1	1	1	2
21	SOCKET, MIXING BOWL	CD67A	1	1	1	1	2
22	SPOUT ASSEMBLY	M934Q	1	1	1	1	-
22	SPOUT ASSEMBLY	M935Q	-	-	-	-	1
23	SPOUT ASSEMBLY	M864Q	-	-	-	-	1
24	TEACH-ME TIMER DUAL	L726A	2	-	2	-	2
24	TEACH-ME TIMER SINGLE	L576A	-	2	-	2	-
25	LEVEL CONTROL DUAL 120V	L690A	1	1	1	1	1
25	LEVEL CONTROL DUAL 240V	L706A	1	1	1	1	1
26	BLOWER HOSE (1" DIA)	CD369	1	1	1	1	1
27	BLOWER/ FAN 120V	CD56A	1	1	1	1	1
27	BLOWER/ FAN 240V	CD166	1	1	1	1	1
28	TRANSFORMER, 24V	CF29A	2	2	2	2	2
29	WARMER ELEMENT, 120V, 60W	G386A	-	1	2	3	-
29	WARMER ELEMENT, 220V, 80W	G110A	-	1	2	3	-
30	AUGER MOTOR 24V, 30 RPM	CD398	2	2	2	2	2
31	PRODUCT GUIDE, LEFT	CD70A	1	1	1	1	1
32	DUAL LEVEL PROBE ASSEMBLY	K695Q	1	1	1	1	1
33	POWER CORD 120V	C032A	1	1	1	1	1
34	POWER CORD 220V	CH50A	1	1	1	1	1
34	FUNNEL	V274Q	-	-	-	-	1
34	FUNNEL	V270Q	1	1	1	1	-
35	HOPPER GUIDE	SL30A	2	2	2	2	2
36	WARMER SWITCH, RED	L217A	-	1	2	3	-
37	SHELF SWITCH	56039	1	-	1	-	1
38	DRIP TRAY INSERT	M973A	1	-	1	-	1
39	DRIP TRAY	UB87Q	1	-	1	-	1
40	DOOR LOCK - OPTIONAL	V275A	1	1	1	1	1
41	DOOR LOCK LATCH - OPTIONAL	SQ84A	1	1	1	1	1

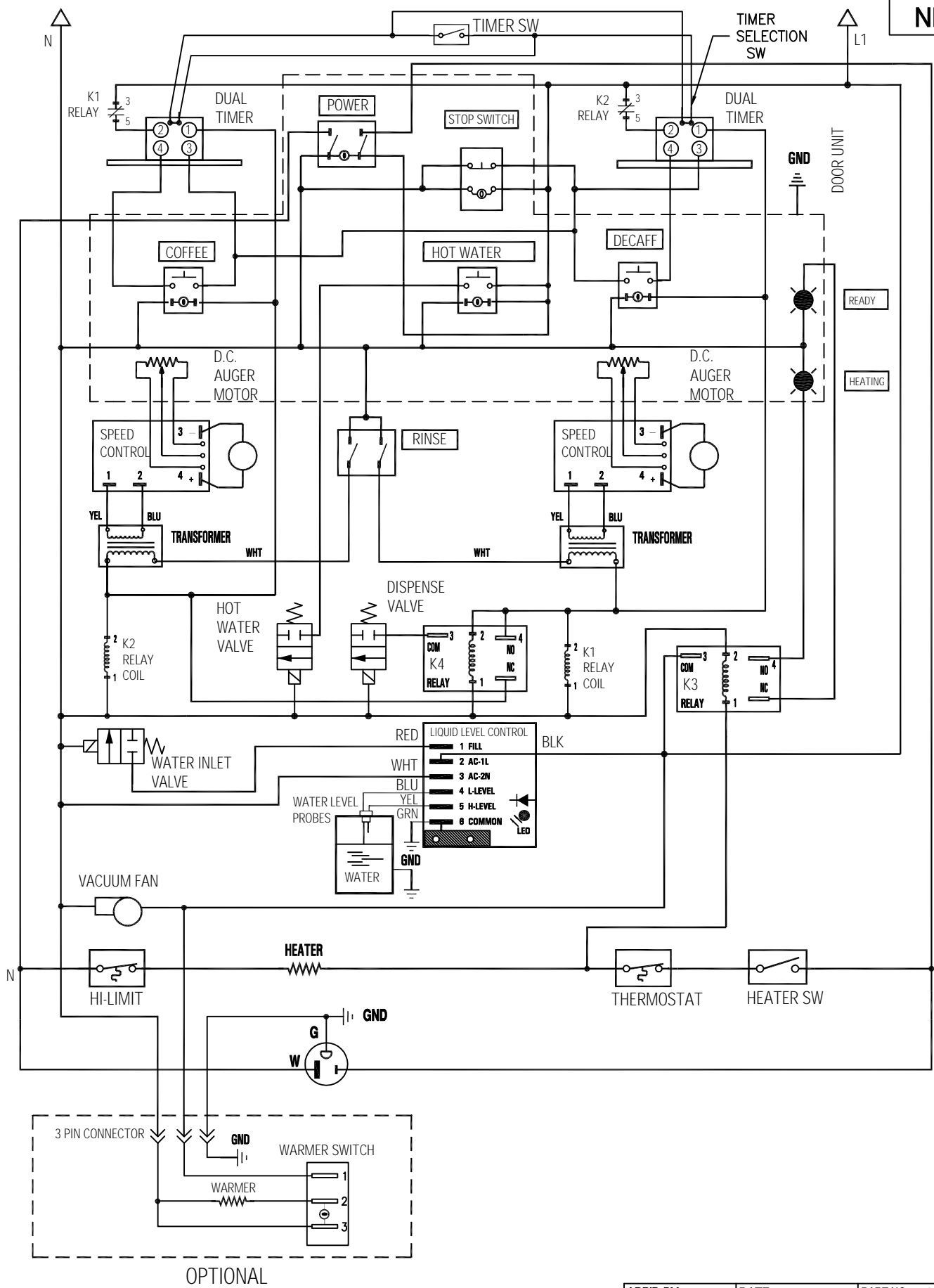

OPTIONAL

REV	BY	DATE	DESCRIPTION	APP'D BY	DATE	PART NO	N207
				JE	05/02/03	SCALE	1:1
<p>CECILWARE CORPORATION 43-05 20 AVE. L.I.C. NY 11105</p>				<p>NE207</p>			
<p>TITLE: ELECTRICAL DIAGRAM (JAVA QB-D & D2) USA-2 VALVES</p>							<p>REV. E</p>

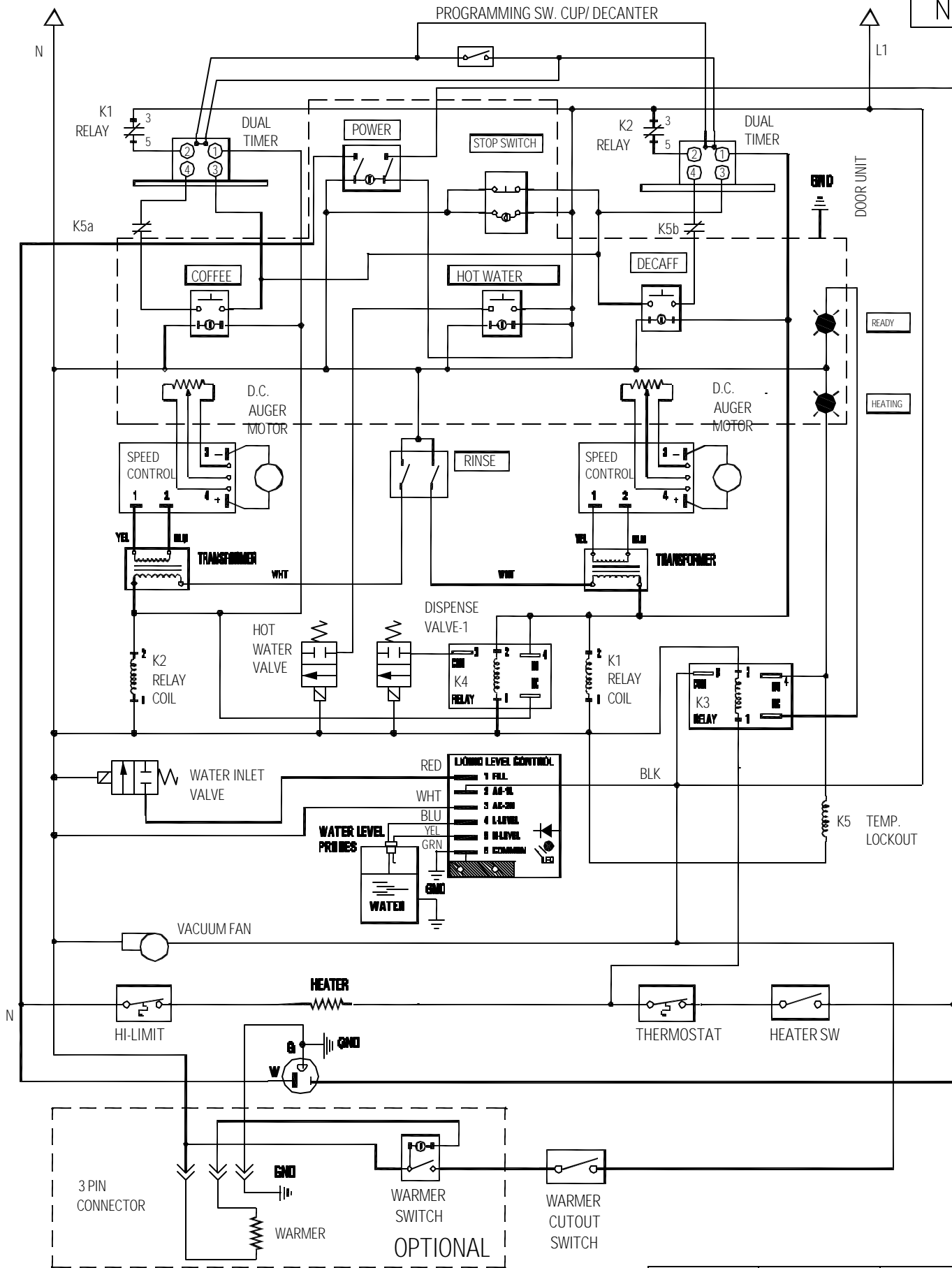

REV	BY	DATE	DESCRIPTION	APP'D BY	DATE	PART NO N216
				DRAWN BY	GV	DATE 05/02/83
<p>CECILWARE CORPORATION 43-05 20 AVE. L.I.C. NY 11105</p>				<p>SCALE 1 : 1</p>		<p>NE216</p>
<p>TITLE: ELECTRICAL DIAGRAM (JAVA QB-D) USA-2VALVES W/ TEMP LOCKOUT</p>						

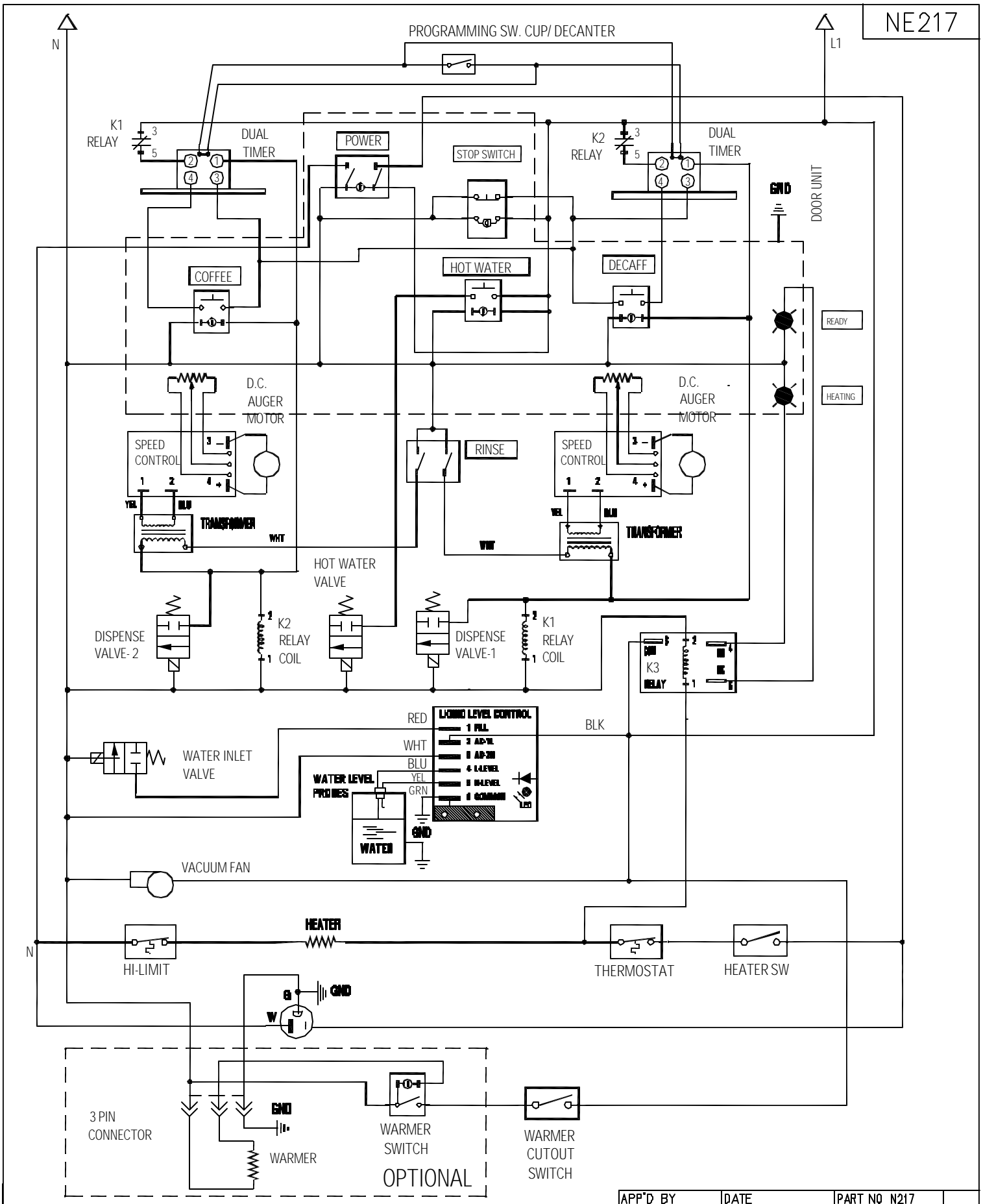

REV	BY	DATE	DESCRIPTION	APP'D BY	DATE	PART NO N217
				DRAWN BY M.M.	DATE 8/21/2003	SCALE 1 : 1
<p>CECILWARE CORPORATION 43-05 20 AVE. L.I.C. NY 11105</p>						
TITLE: ELECTRICAL DIAGRAM (JAVA QB-DC) CANADA-3 VALVES						REV. A

NE217

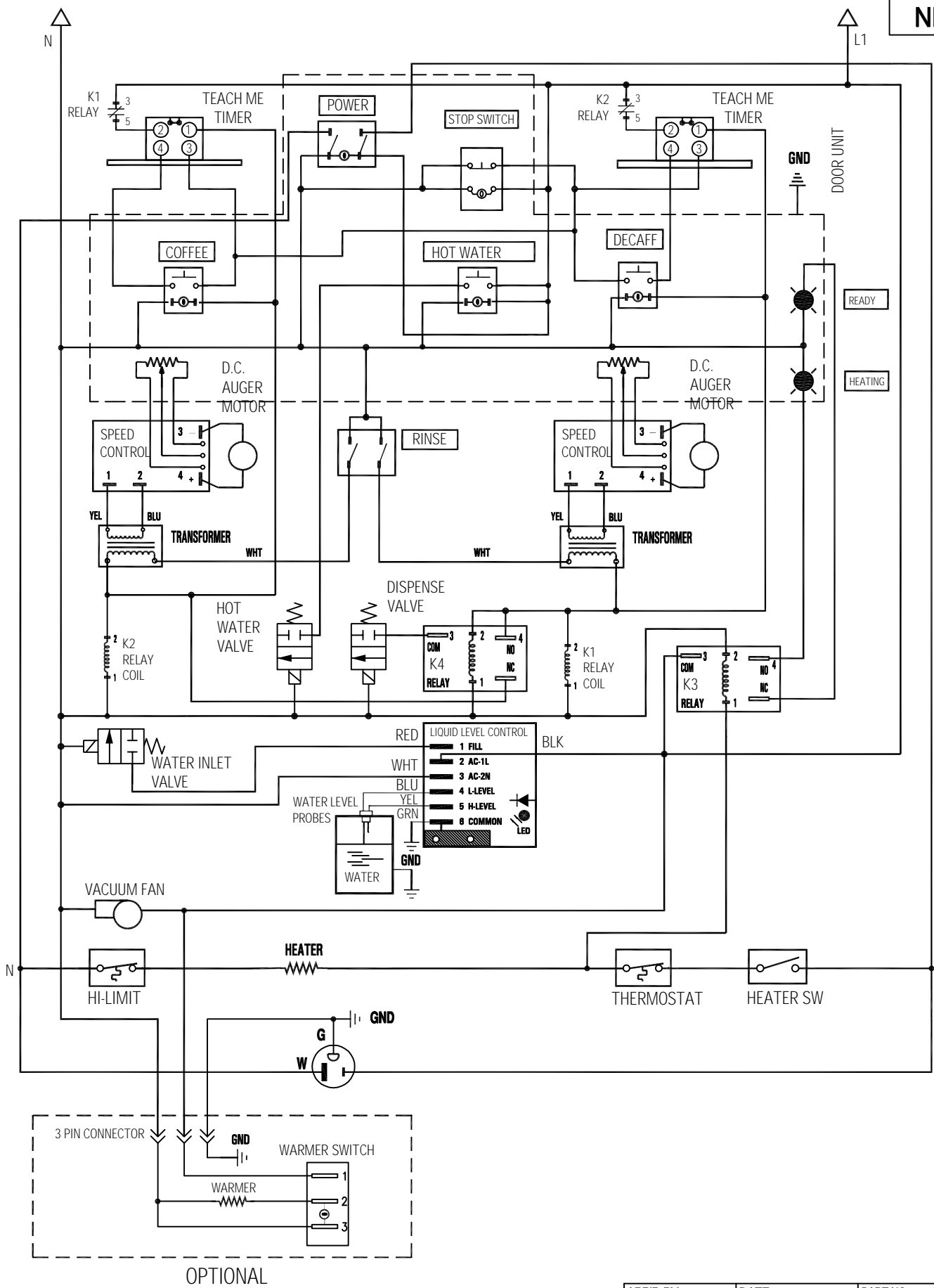

REV	BY	DATE	DESCRIPTION	APP'D BY	DATE	PART NO	NE228
				DRAWN BY	M.M.	DATE	2/5/2004
						SCALE	1:1
<p>CECILWARE CORPORATION 43-05 20 AVE. L.I.C. NY 11105</p>							
TITLE: ELECTRICAL DIAGRAM (JAVA QB-D1 & D3) USA-2 VALVES							REV. A

NE228