

Heavy Duty Hot Water Dispenser

HWD3 - HWD5



HWD3PC - HWD5PC



HWD2



SPECIAL FEATURES:

- * PRECISION THERMOSTAT FOR ACCURATE TEMPERATURE CONTROL
- * SOLID-STATE LEVEL CONTROL FOR CONTINUOUS HOT WATER FLOW
- * INSTANT HOT WATER FOR PREPARING:
INSTANT COFFEE, HOT CEREAL, PUDDING, GELATIN, COCOA, SOUP, TEA.

Cecilware sells value... Worldwide

Cecilware Corporation

43-05 20th Avenue, Long Island City, NY 11105

Tel: 718-932-1414
1-800-935-2211

Fax: 718-932-7860
E-Mail: customer.service@cecilware.com



HOT WATER DISPENSERS

INSTALLATION INSTRUCTIONS

The *Hot Water Dispenser* is shipped, from the factory, with the Heater Switch in the "OFF" position. **DO NOT** turn the heater switch **ON** until the unit is primed with water. The heater switch is located at the lower back of the unit.

WATER INLET CONNECTION :

The *Hot Water Dispenser* is to be installed to comply with all applicable Federal, State and Local plumbing codes. Furthermore, a quick disconnect or enough extra coiled tubing, (at least 2 times the depth of the machine) should be installed, so that the unit can be moved for proper cleaning underneath. It is recommended that an approved back flow prevention device, such as a double check valve, and a shut-off valve should be installed between the *Hot Water Dispenser* and incoming water supply.

START - UP PROCEDURE:

CAUTION: MAKE SURE THE **HEATER SWITCH**, LOCATED AT THE LOWER BACK OF THE UNIT, IS IN THE **OFF** POSITION.

1. Connect a ¼" diameter copper waterline to the ¼" flare water inlet.
2. Open the water shut-off valve and check connections for leaks. **DO NOT** over-tighten.
3. Plug in the *Hot Water Dispenser* into a dedicated power supply outlet.
4. Activate the **Power Switch** (front of unit) the water tank will begin to fill, providing the water connection is open. The tank will fill in approximately 3-4 minutes.
5. After the tank has filled, activate the **Heater Switch** (toggle up, lower back of unit). Depending on the model selected, it will take approximately 15-25 minutes for the water to heat to operating temperature.

NOTE: This procedure is for initial start - up only; however, steps 4 and 5 must be repeated should the tank be completely drained. Steps 1 thru 5 must be repeated should the machine be drained, disconnected and reinstalled in a new location.

THERMOSTAT ADJUSTMENT:

Remove the two (2) screws from the top cover and remove cover. The thermostat, will be visible. First, adjust the thermostat by turning the thermostat knob either clockwise to raise the temperature, or counter clockwise to lower the temperature. If further adjustment is required, remove knob, turn the adjustment screw, located in the center of the thermostat shaft, counter clockwise to increase the temperature and clockwise to decrease the temperature. Unit should be set to approximately 203°F.

TROUBLESHOOTING GUIDE

WARNING: Always disconnect HWD from power supply before repairing or replacing any internal components.

TROUBLE	PROBABLE CAUSE	REMEDY
DOES NOT FILL	1. Water supply off 2. Line cord not plugged in 3. Power switch off 4. Circuit breaker tripped 5. Power switch inoperative 6. Solenoid valve inoperative 7. Level control inoperative	Turn water supply on Plug in line cord Turn power switch on Reset breaker Replace power switch Replace solenoid Replace level control
WATER CONTINUES TO FLOW FROM OVERFLOW	1. Leaking solenoid valve 2. Level probe dirty	Replace solenoid Clean or replace probe
COLD WATER	1. Heater switch in OFF position 2. Thermostat in OFF position 3. Thermostat defective 4. High limit switch defective 5. Heater element defective 6. Loose electrical connection(s)	Turn heater ON Turn thermostat ON Replace thermostat Replace high limit switch Replace heater element Tighten all loose connections
WATER BOILS CONTINUOUSLY	1. Thermostat out of calibration 2. Thermostat defective	Adjust thermostat as listed above Replace thermostat



Hot Water Dispenser - HWD2

Tomlinson faucet Manual dispense

Electrical Specifications

MODEL NO	VOLTS	WATTS	PHASE & CYCLES	POWER CORD (included)	RECEPTACLE
HWD2	120	1700	1 PH. 50/60 Hz	P5-15	R5-15
	240	3000	1 PH. 50/60 Hz	P6-15	R6-15

Export units add "X" to Model No.

Specify Voltage and type of line cord required.

Water Connection

Water pressure: 20 - 90 PSI (69 - 621 KPA) Supplied with ¼ OD male flare fitting

Operational

MODEL NO	VOLTS	INITIAL HEAT-UP TIME	BURST CAPACITY	RECOVERY	GALLONS PER HOUR	TANK CAPACITY
HWD2	120 (1.7 KW)	20-25 Min	1.5 Gals	10-15 Min	4.5	2.8 Gal
	240 (3.0 KW)	15-20 Min	2.0 Gals	5-10 Min	8.0	

Heat-up time and Dispense rate based on Inlet water temperature at 68°F and Dispense water temperature range 165°F to 200°F

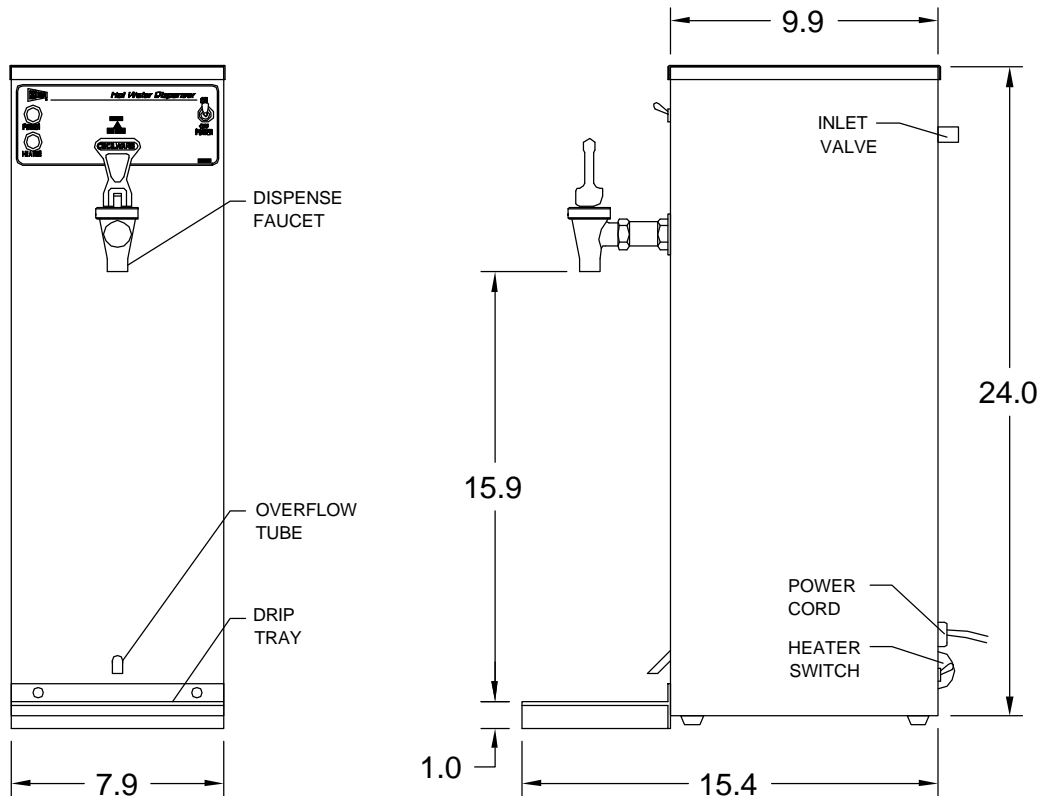

TOP VIEW

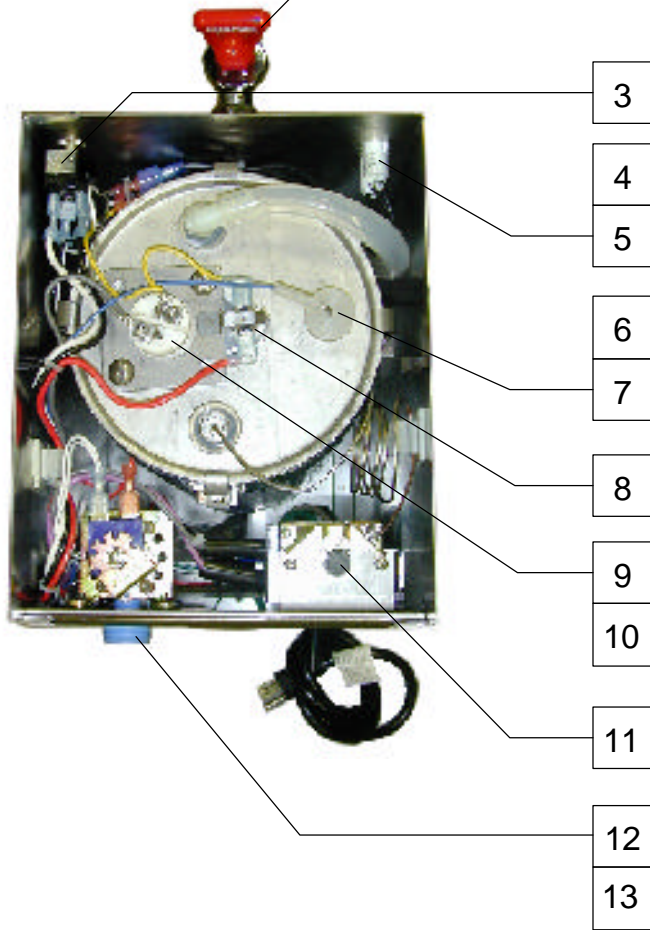

REAR VIEW

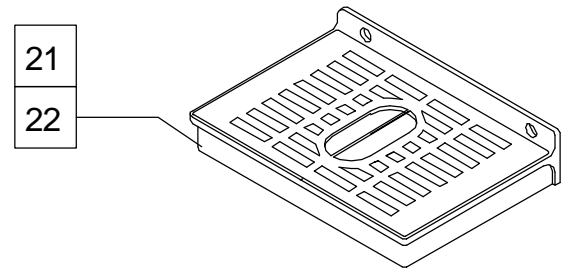
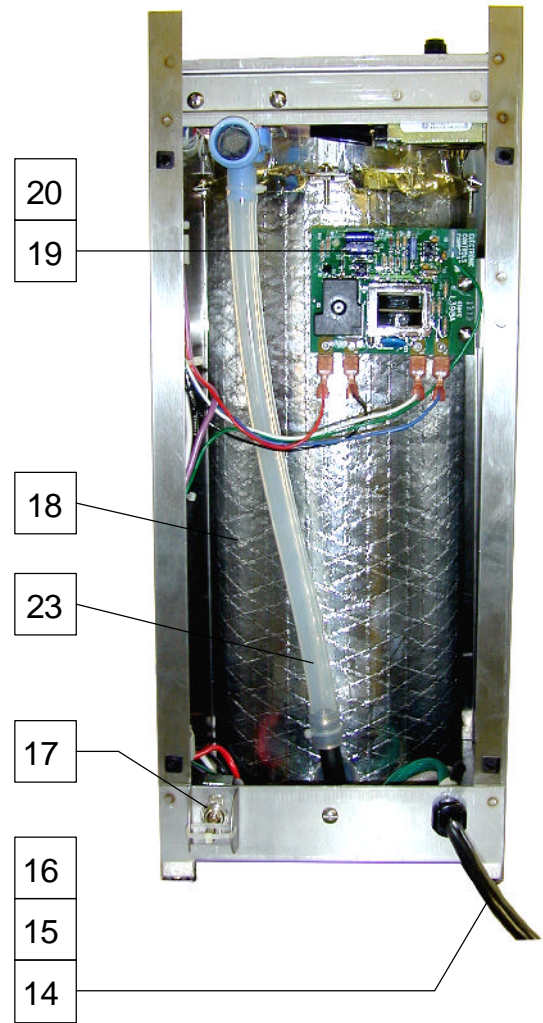

PARTS LIST HWD2

ITEM	DESCRIPTION	PART NO
1	FAUCET	80234
2	FAUCET SHANK	77203
3	POWER SWITCH	L069A
4	POWER LIGHT - RED	C165A
5	HEATER LIGHT - AMBER	C260A
6	SILICONE SEAL 12mm (0.466 I.D.)	M461A
7	LEVEL CONTROL PROBE	K402Q
8	HI-LIMIT 220° CUTOUT	L573A
9	HEATER ELEMENT, 120V 1700W	G267A
10	HEATER ELEMENT, 240V 3000W	G266A
11	THERMOSTAT	L532A
12	WATER INLET VALVE, 120V	L462A

13	WATER INLET VALVE, 240V COIL	C223A
14	STRAIN RELIEF	B012A
15	LINE CORD, 120V 15A	C032A
16	LINE CORD, 240V 15A	C770A
17	HEATER SWITCH	L069A
18	WATER TANK, HWD2	40799
19	WATER LEVEL CONTROL, 120V	L398A
20	WATER LEVEL CONTROL, 240V	L599A
21	DRIP TRAY PAN	75014
22	DRIP TRAY GRILL	75015
22	SILICONE HOSE 3/8ID x 16" LG	M857A



Hot Water Dispenser - HWD3

Tomlinson faucet Manual dispense

Electrical Specifications

MODEL NO	VOLTS	WATTS	PHASE & CYCLES	POWER CORD (included)	RECEPTACLE
HWD3	120	1700	1 PH. 50/60 Hz	P5-15	R5-15
	240	3000	1 PH. 50/60 Hz	P6-15	R6-15

Export units add "X" to Model No.

Specify Voltage and type of line cord required.

Water Connection

Water pressure: 20 - 90 PSI (69 - 621 KPA) Supplied with ¼ OD male flare fitting

Operational

MODEL NO	VOLTS	INITIAL HEAT-UP TIME	BURST CAPACITY	RECOVERY	GALLONS PER HOUR	TANK CAPACITY
HWD3	120 (1.7 KW)	20-25 Min	1.5 Gals	10-15 Min	4.5	2.8 Gal
	240 (3.0 KW)	15-20 Min	2.0 Gals	5-10 Min	8.0	

Heat-up time and Dispense rate based on Inlet water temperature at 68°F and

Dispense water temperature range 165°F to 200°F

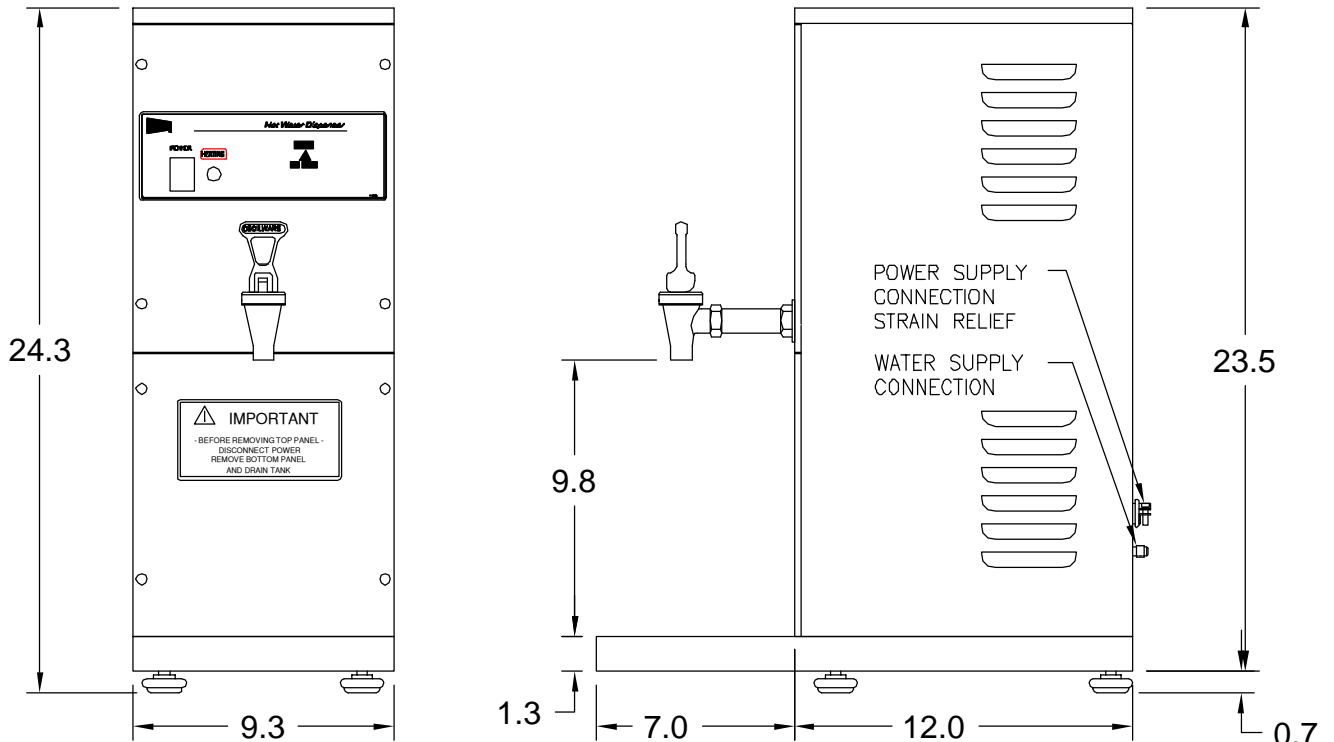



Hot Water Dispenser - HWD5

Tomlinson faucet Manual dispense

Electrical Specifications

MODEL NO	VOLTS	WATTS	PHASE & CYCLES	POWER CORD (included)	RECEPTACLE
HWD5	120	1700	1 PH. 50/60 Hz	P5-15	R5-15
	240	3000	1 PH. 50/60 Hz	P6-15	R6-15
	240	6000	1 PH. 50/60 Hz	P6-30	R6-30

Export units add "X" to Model No.

Specify Voltage and type of line cord required.

Water Connection

Water pressure: 20 - 90 PSI (69 - 621 KPA) Supplied with ¼ OD male flare fitting

Operational

MODEL NO	VOLTS	INITIAL HEAT-UP TIME	BURST CAPACITY	RECOVERY	GALLONS PER HOUR	TANK CAPACITY
HWD5	120 (1.7 KW)	30-45 Min	2.0 Gals	20-25 Min	5.0	5.0 Gal
	240 (3.0 KW)	20-25 Min	3.0 Gals	15-20 Min	9.0	
	240 (6.0 KW)	15-20 Min	4.0 Gals	10-15 Min	14.0	

Heat-up time and Dispense rate based on Inlet water temperature at 68°F and

Dispense water temperature range 165°F to 200°F

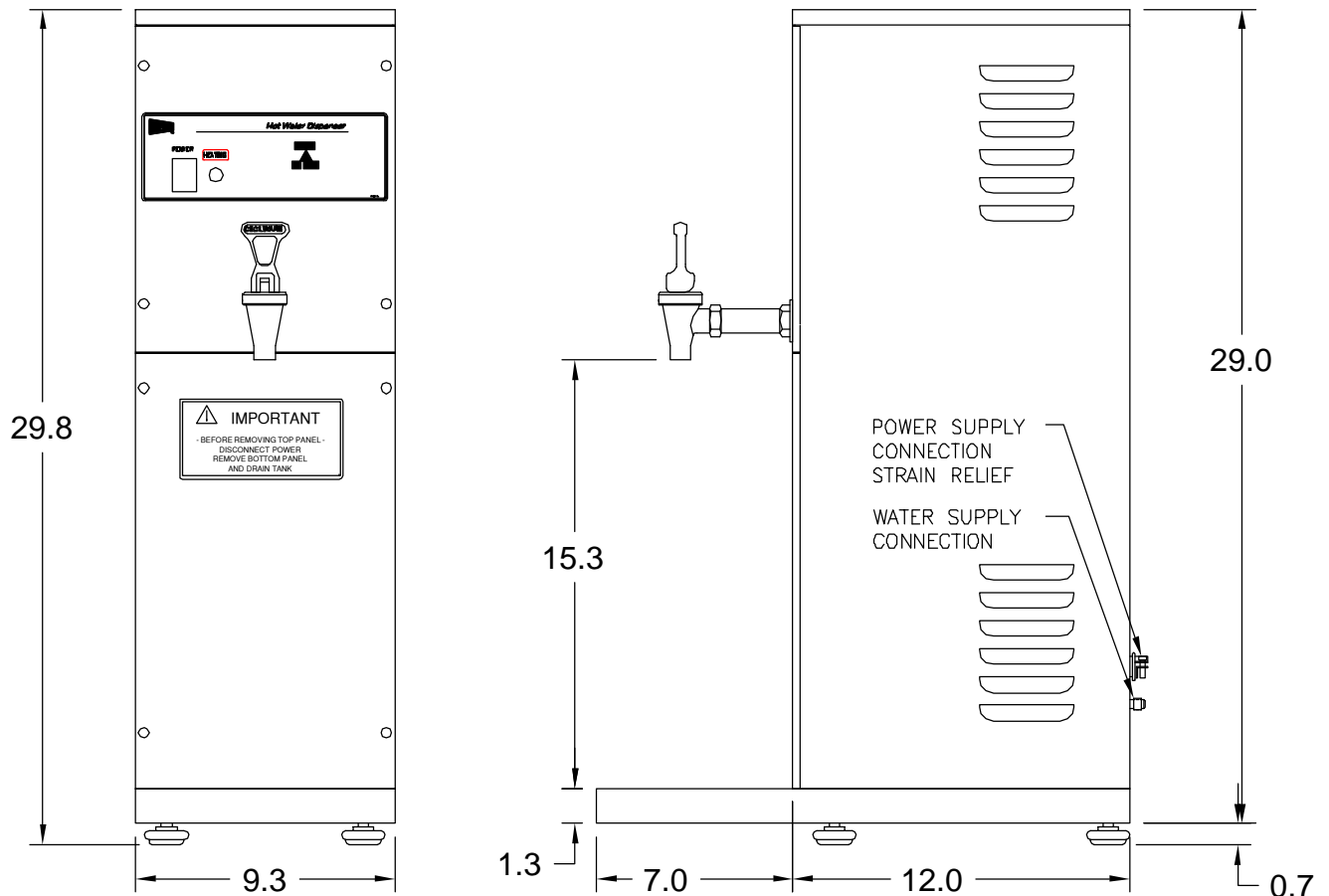

TOP VIEW

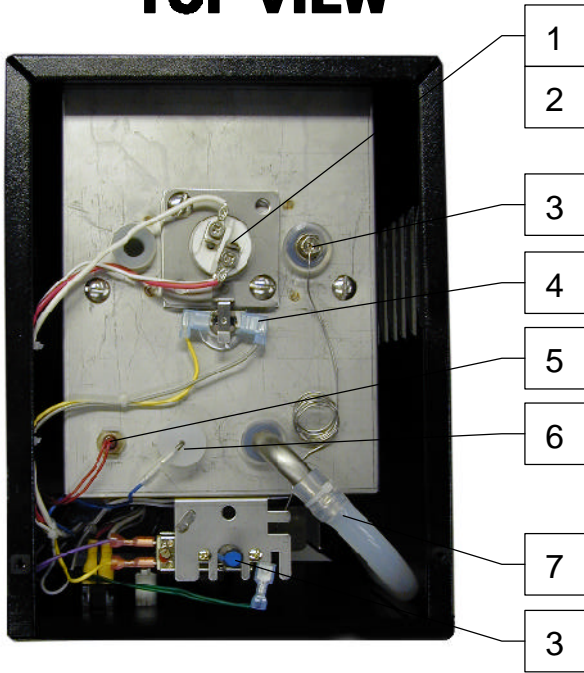

FRONT VIEW

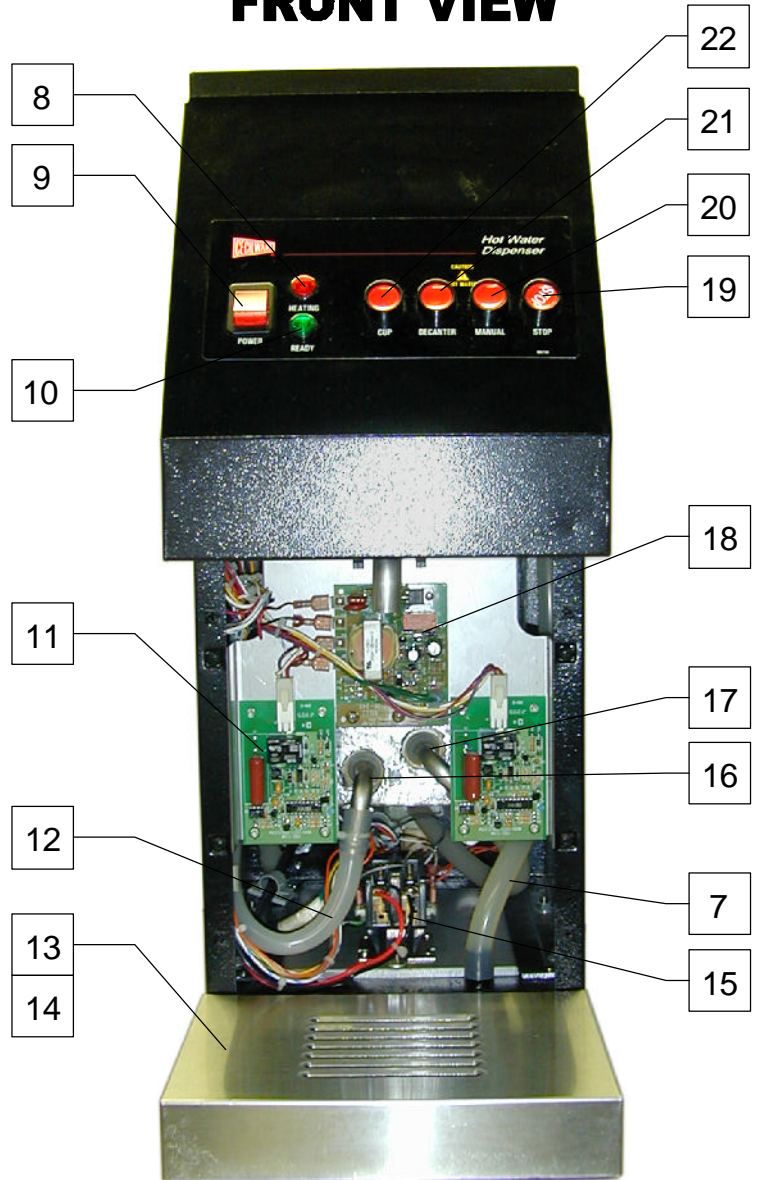

REAR VIEW

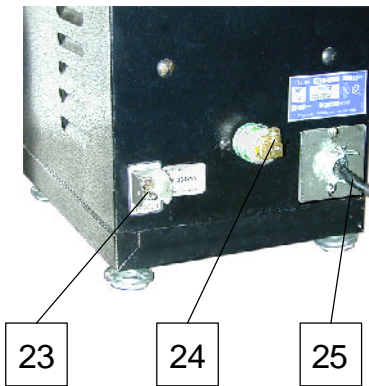

PARTS LIST HWD3PC - HWD5PC

ITEM	DESCRIPTION	PART NO		
1	HEATER ELEMENT, 120V 1700W	G267A	14	DRIP TRAY GRILL SA73A
2	HEATER ELEMENT, 240V 3000W	G266A	15	CONTACTOR, 2 POLE 30/40 AMP, 120V B177A
3	THERMOSTAT	L532A	16	SILICONE HOSE 3/8ID x 16" LG M857A
4	HI-LIMIT 220° CUTOUT	L573A	17	SILICONE SEAL 12mm (0.466 I.D.) M461A
5	FLOAT SWITCH	L499A	18	LEVEL CONTROL L566A
6	LEVEL CONTROL PROBE	K402Q	19	"STOP" SWITCH PB L584A
7	SILICONE HOSE 3/8ID x 16" LG	M857A	20	"MANUAL" SWITCH PB L584A
8	PILOT LIGHT "HEATING"	C165A	21	"DECANTER" SWITCH PB L584A
9	POWER SWITCH	L155A	22	"CUP" SWITCH PB L584A
10	PILOT LIGHT "READY"	C072A	23	"HEATER" SWITCH L069A
11	TEACH-ME TIMER	L576A	24	WATER INLET VALVE, 120V L462A
12	SILICONE HOSE 3/8ID x 16" LG	M857A	25	POWER CORD 120V C032A
13	DRIP TRAY PAN	SA72A		

HOT WATER DISPENSERS

Models HWD3PC and HWD5PC

PROGRAMMABLE TIMER "TEACH ME" ADJUSTMENTS

This timer can be programmed from the push buttons to dispense different volumes of hot water.

PROGRAMMING INSTRUCTIONS FOR AUTOMATIC DISPENSE

1. Turn Power Switch ON.
2. PRESS and HOLD [red] STOP Button with one hand.
3. PRESS and HOLD [green] DISPENSE Button with other hand.
4. RELEASE [red] STOP Button ONLY.
5. Continue to HOLD [green] DISPENSE Button for 5 SECONDS, then RELEASE.
6. PRESS and RELEASE [green] DISPENSE Button. Product begins dispensing. When it reaches the "DESIRED VOLUME",
7. PRESS and RELEASE [green] DISPENSE Button to SET "DESIRED VOLUME". DISPENSE Button can be "jogged" to top off.
8. PRESS and RELEASE [red] STOP button to LOCK IN "DESIRED VOLUME". Repeat steps 1 to 8 for each Dispense Button.

PROGRAMMING INSTRUCTIONS FOR MANUAL DISPENSE

1. Turn Power Switch ON.
 2. PRESS and HOLD [red] STOP Button with one hand.
 3. PRESS and HOLD [green] DISPENSE Button with other hand.
 4. RELEASE [red] STOP Button ONLY.
 5. Continue to HOLD [green] DISPENSE Button for 5 SECONDS, then RELEASE.
 6. PRESS and RELEASE [red] STOP Button. Unit is in MANUAL DISPENSE mode.
-



Hot Water Dispenser - HWD3PC

Push Button with Portion control or Manual dispense

Electrical Specifications

MODEL NO	VOLTS	WATTS	PHASE & CYCLES	POWER CORD (included)	RECEPTACLE
HWD3PC	120	1700	1 PH. 50/60 Hz	P5-15	R5-15
	240	3000	1 PH. 50/60 Hz	P6-15	R6-15

Export units add "X" to Model No.
Specify Voltage and type of line cord required.

Water Connection

Water pressure: 20 - 90 PSI (69 - 621 KPA) Supplied with ¼ OD male flare fitting

Operational

MODEL NO	VOLTS	INITIAL HEAT-UP TIME	BURST CAPACITY	RECOVERY	GALLONS PER HOUR	TANK CAPACITY
HWD3PC	120 (1.7 KW)	20-25 Min	1.5 Gals	10-15 Min	4.5	2.8 Gal
	240 (3.0 KW)	15-20 Min	2.0 Gals	5-10 Min	6.0	

Heat-up time and Dispense rate based on Inlet water temperature at 68°F and Dispense water temperature range 165°F to 200°F

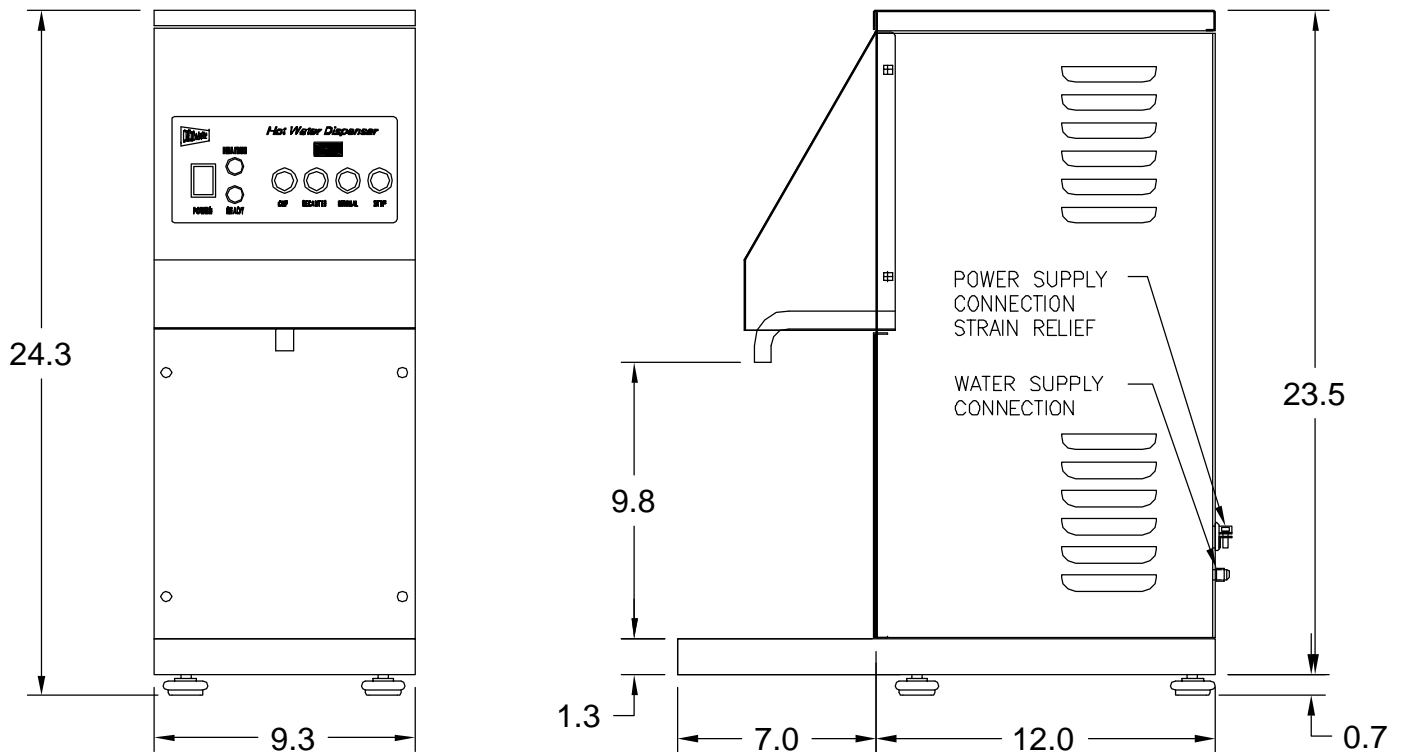



Hot Water Dispenser - HWD5PC

Push Button with Portion control or Manual dispense

Electrical Specifications

MODEL NO	VOLTS	WATTS	PHASE & CYCLES	POWER CORD (included)	RECEPTACLE
HWD5PC	120	1700	1 PH. 50/60 Hz	P5-15	R5-15
	240	3000	1 PH. 50/60 Hz	P6-15	R6-15
	240	6000	1 PH. 50/60 Hz	P6-30	R6-30

Export units add "X" to Model No.

Specify Voltage and type of line cord required.

Water Connection

Water pressure: 20 - 90 PSI (69 - 621 KPA) Supplied with ¼ OD male flare fitting

Operational

MODEL NO	VOLTS	INITIAL HEAT-UP TIME	BURST CAPACITY	RECOVERY	GALLONS PER HOUR	TANK CAPACITY
HWD5PC	120 (1.7 KW)	30-45 Min	2.0 Gals	20-25 Min	5.0	5.0 Gal
	240 (3.0 KW)	20-25 Min	3.0 Gals	15-20 Min	9.0	
	240 (6.0 KW)	15-20 Min	4.0 Gals	10-15 Min	14.0	

Heat-up time and Dispense rate based on Inlet water temperature at 68°F and

Dispense water temperature range 165°F to 200°F

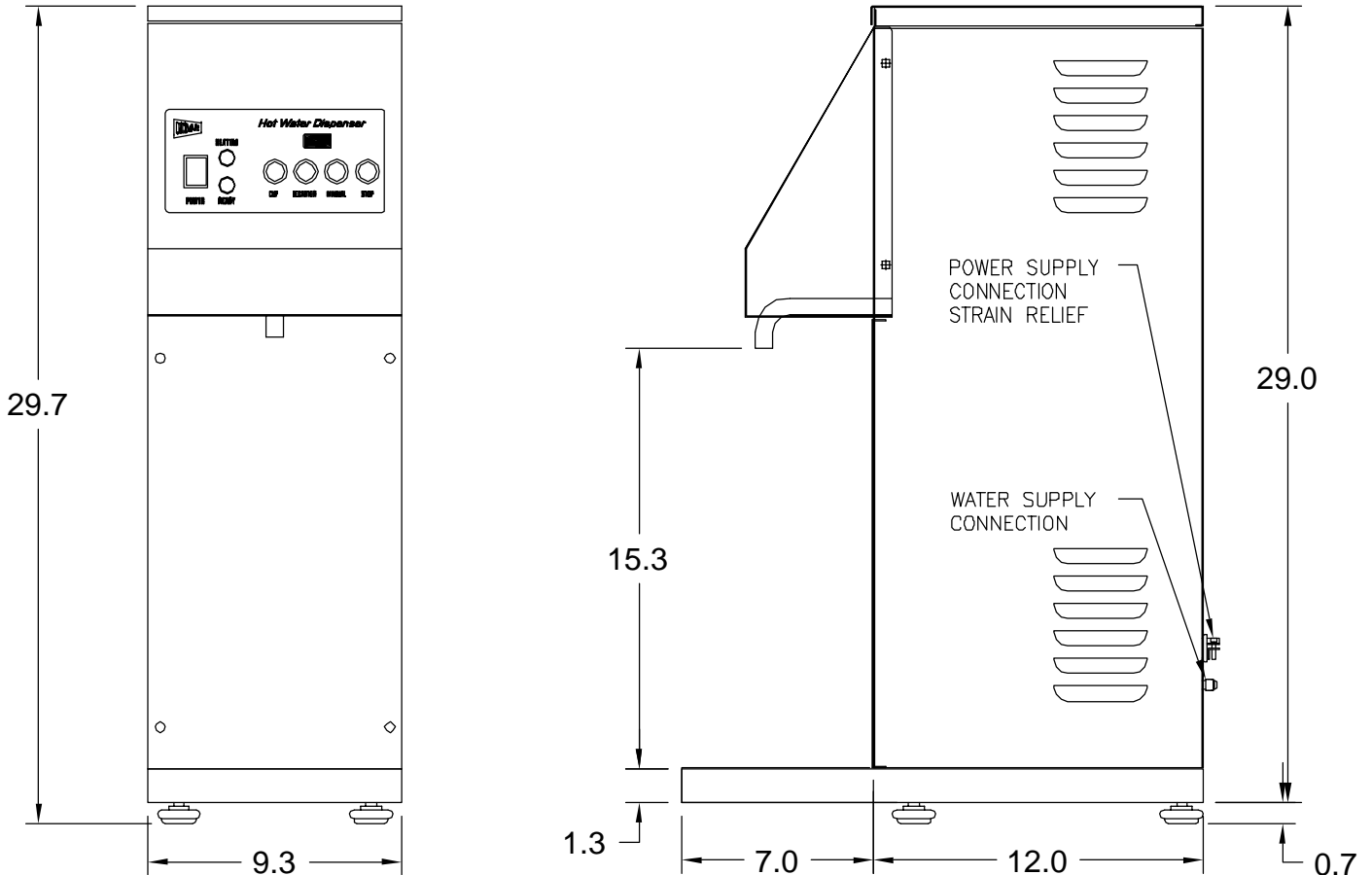

TOP VIEW

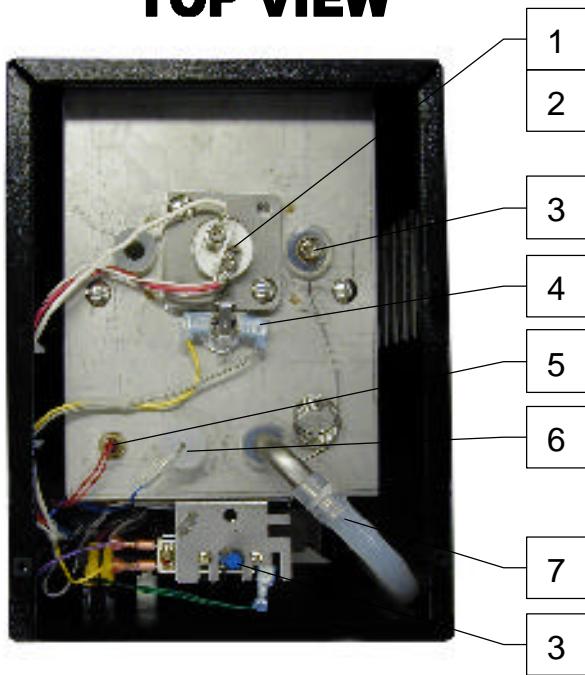

FRONT VIEW

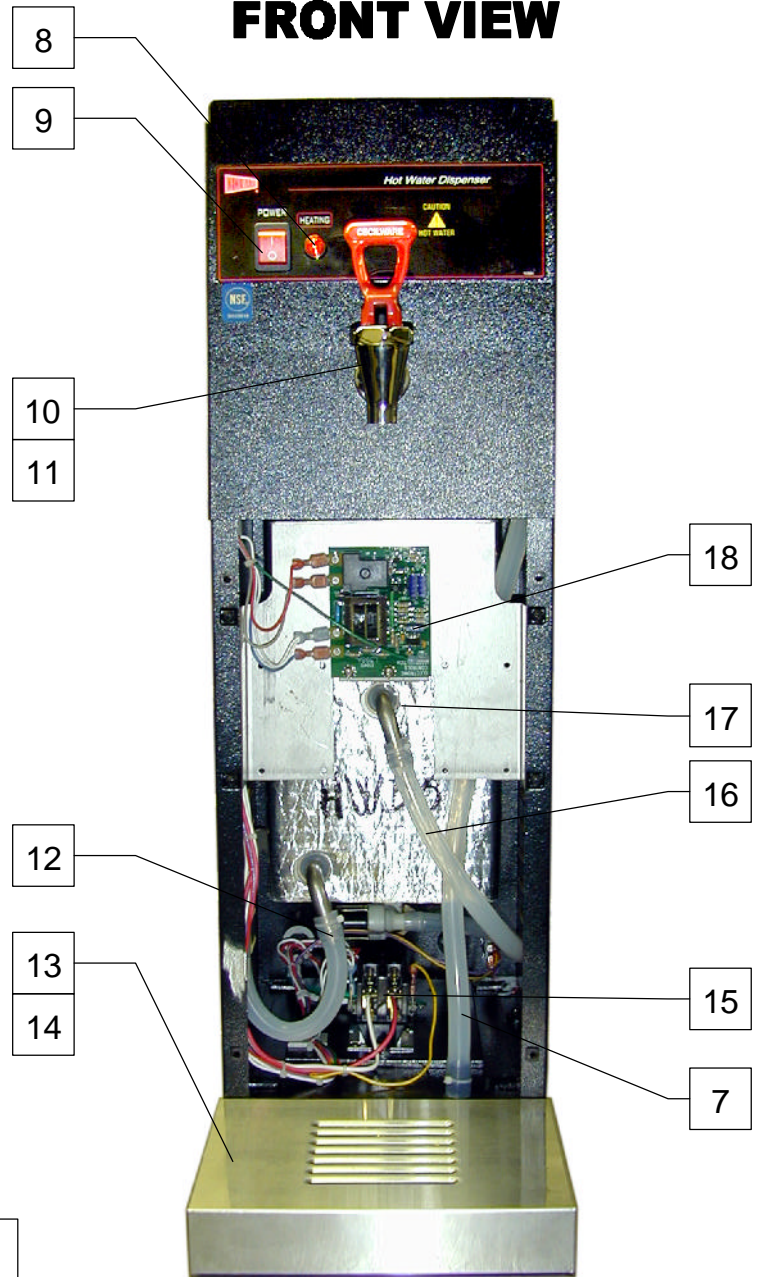

REAR VIEW

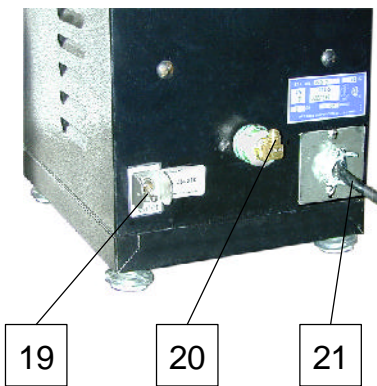

PARTS LIST HWD3 - HWD5

ITEM	DESCRIPTION	PART NO			
1	HEATER ELEMENT, 120V 1700W	G267A	14	DRIP TRAY GRILL	SA73A
2	HEATER ELEMENT, 230V 6000W	G281A	15	CONTACTOR, 2 POLE 30/40 AMP, 120V	B177A
3	THERMOSTAT	L532A	16	SILICONE HOSE 3/8ID x 16" LG	M857A
4	HI-LIMIT 220° CUTOOUT	L573A	17	SILICONE SEAL 12mm (0.466 I.D.)	M461A
5	FLOAT SWITCH	L499A	18	LEVEL CONTROL	L566A
6	LEVEL CONTROL PROBE	K402Q	19	"HEATER" SWITCH	L069A
7	SILICONE HOSE 3/8ID x 16" LG	M857A	20	WATER INLET VALVE, 120V	L462A
8	PILOT LIGHT "HEATING"	C165A	21	POWER CORD 120V	C032A
9	POWER SWITCH	L155A			
10	FAUCET	80234			
11	SHANK SUB-ASSEMBLY	D094Q			
12	SILICONE HOSE 3/8ID x 16" LG	M857A			
13	DRIP TRAY PAN	SA72A			

ELECTRICAL DIAGRAM HWD2

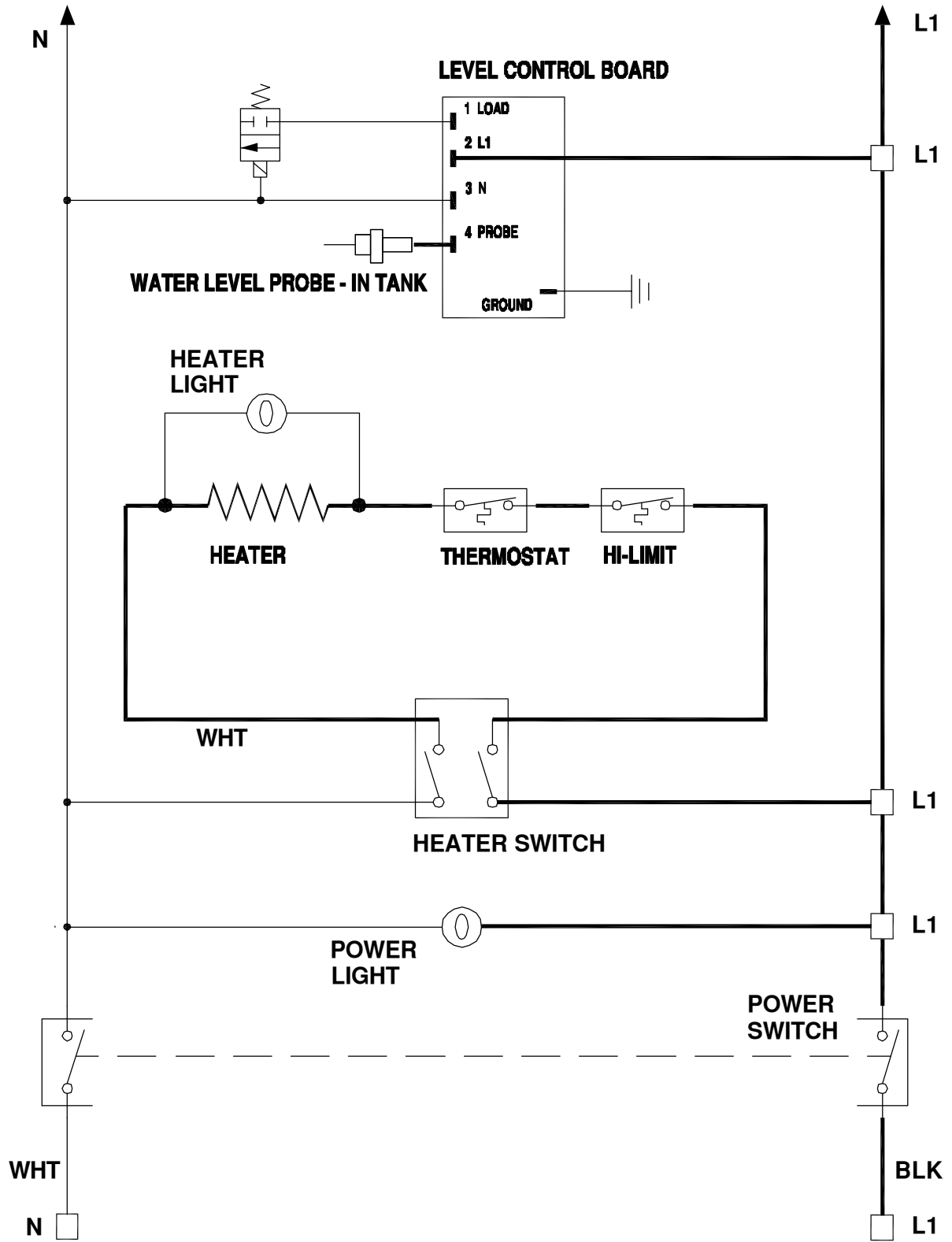

G	G.V.	2/22/99	REVISED	APP'D BY	DATE	PART NO NE103
REV	BY	DATE	DESCRIPTION	DRAWN BY G.V.	DATE 1/14/99	SCALE 1 : 1
CECILWARE CORPORATION				43-05 20 AVE. L.I.C. NY 11105		
TITLE: ELECTRICAL DIAGRAM HWD2, HWD3 (120V 240V)						REV.

ELECTRICAL DIAGRAM HWD3PC-HWD5PC

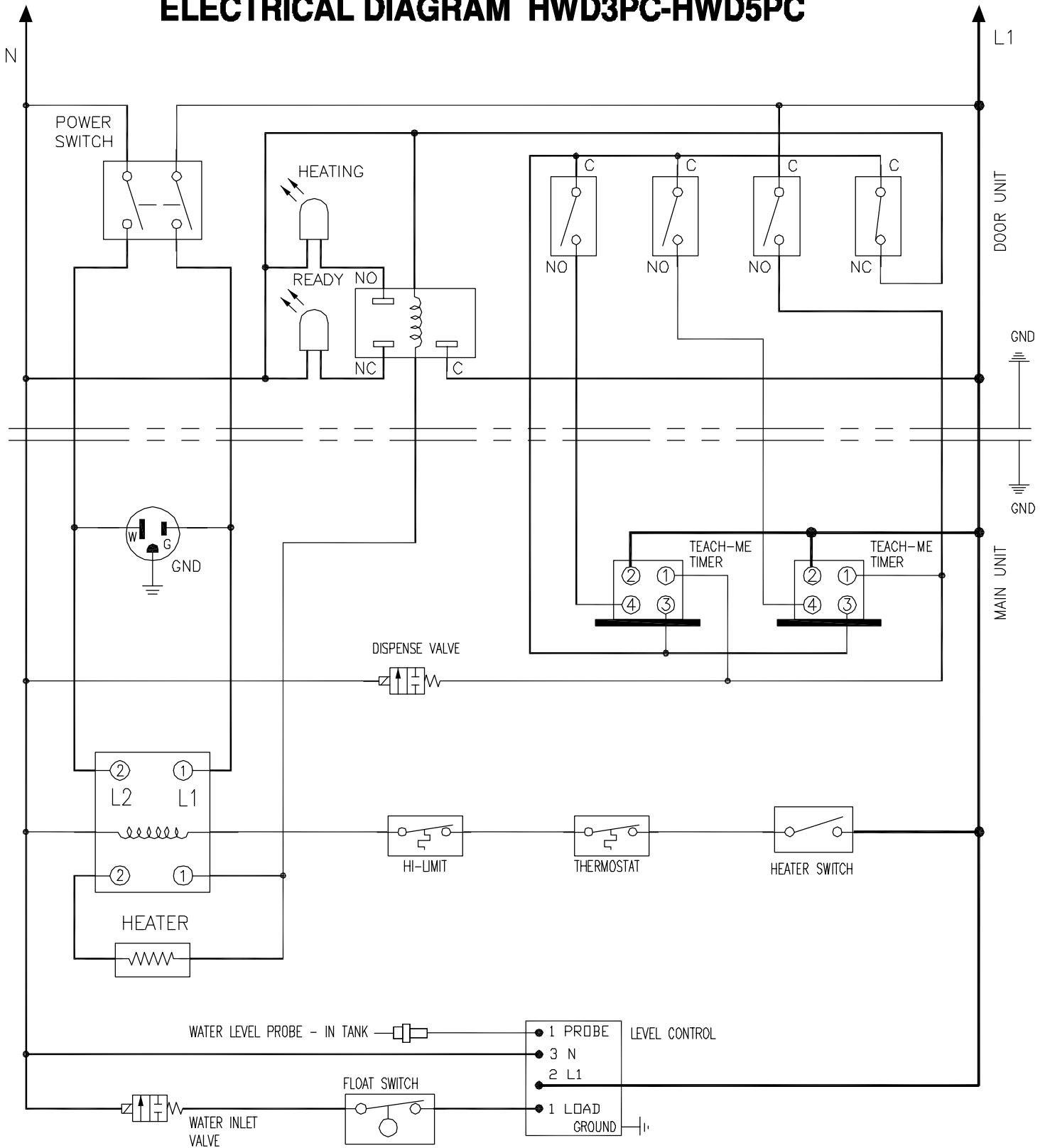

REV	BY	DATE	DESCRIPTION	APP'D BY	DATE	PART NO	SCALE
					7/27/99	NE119	1 : 1
<p>CECILWARE CORPORATION 43-05 20 AVE. L.I.C. NY 11105</p>							
<p>TITLE: ELECTRICAL DIAGRAM (HWD3PC & HWD5PC)</p>							<p>REV. A</p>

NE119

ELECTRICAL DIAGRAM HWD3 - HWD5

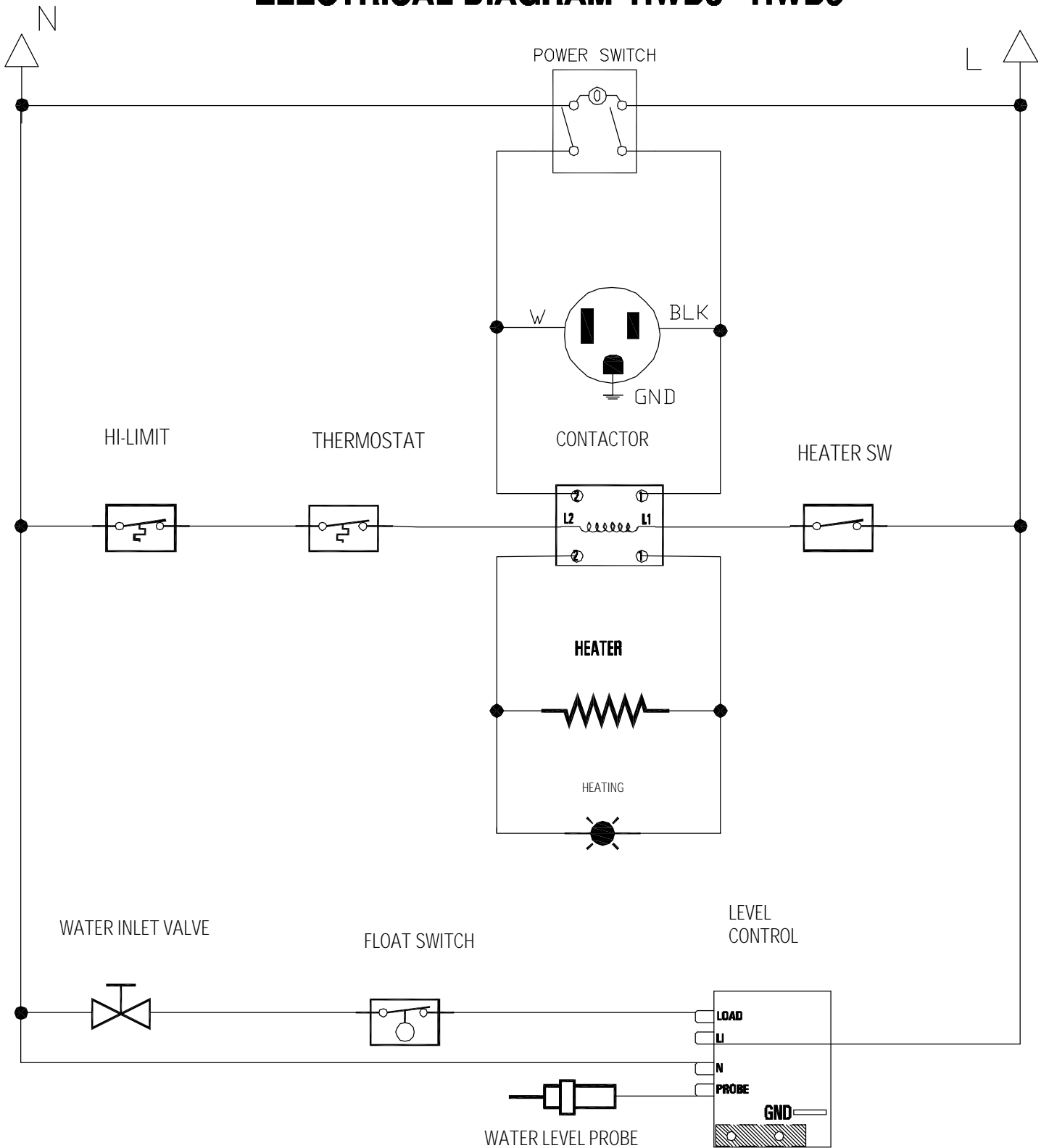

REV	BY	DATE	DESCRIPTION	APP'D BY	DATE	PART NO NE168
				DRAWN BY JE	DATE 10/08/01	SCALE 1:1
CECILWARE CORPORATION				43-05 20 AVE. L.I.C. NY 11105		
TITLE: ELECTRICAL DIAGRAM (HWD3, HWD5)						REV.