

CAPPUCCINO DISPENSERS

GB5MV-10-LD

GB6MP-10-LD-U
GB8MP-10-LD-U



Vista

GB5MV-10-LD

Panorama

GB6MP-10-LD-U



Cecilware sells value... Worldwide

Cecilware Corporation

43-05 20th Avenue, Long Island City, NY 11105

Tel: 718-932-1414

Fax: 718-932-7860

800-935-2211

E-Mail: customer.service@cecilware.com



Website: www.cecilware.com

Operation Manual
NL48P July 2005

CONTENTS

| | |
|-------------------------------------|----|
| Important Owner Information | 1 |
| Introduction | 1 |
| Important Safety Instructions | 2 |
| Model Description | 3 |
| Specifications | 3 |
| Plug Configurations | 3 |
| Installation | 4 |
| Start-up Procedure | 5 |
| Troubleshooting Guide | 6 |
| Recommended Cleaning and Sanitizing | 7 |
| Dual Probe Liquid Level Controller | 8 |
| Components Tests | 9 |
| Hopper Assembly | 10 |
| Whipper Chambers | 11 |
| Body Frame | 12 |
| Electrical Chassis | 21 |
| Upper Door | 22 |
| Lower Door | 23 |
| Hot Water Tanks | 24 |
| Electrical diagram | 26 |

IMPORTANT OWNER INFORMATION

Record the model number, serial number (identification plate is located behind front door), voltage and purchase date of your Cecilware Cappuccino Dispenser in the spaces below. Please have the information available when calling Cecilware for assistance.

Model #: _____

Serial #: _____

Voltage: _____

Date of Purchase: _____

Business Hours: 8:30 a.m. to 5:00 p.m.
Eastern Standard Time

Telephone: 800-935-2211; 718-932-1414

Fax: 718-932-7860



Additional information can be found by visiting our web site at www.cecilware.com

INTRODUCTION

The Cecilware 5, 6, & 8 head instant Cappuccino Dispenser is designed to meet the exact needs of the Convenience Store atmosphere.

Cecilware has led the way in the highly profitable and growing market of Cappuccino with its GB series of Automatic Cappuccino Dispensers. Having set the standard for reliability, Cecilware also leads the way in variety with over 50 different models to choose from.

With the introduction of Cecilware GB5MV-10-LD, GB6MP-10-LD-U & GB8MP-10-LD-U designed exclusively to fit the increasing demand for Cappuccino sales, the hot beverage area has become to be known as “Destination Cappuccino.”

This manual provides the installation, safety and operating instructions for the “Destination Cappuccino” Dispensers. We recommend all installation, operating and safety instructions appearing in this manual be read prior to installation or operation of your Cecilware Cappuccino Dispenser. Safety instructions that appear in this manual after a warning symbol  and the words **WARNING** or **CAUTION** printed in bold face are very important.  **WARNING** means that there is the possibility of serious injury or death to yourself or others.  **CAUTION** means there is the possibility of minor or moderate injury. CAUTION without the symbol signifies the possibility of equipment or property damage only.

Cecilware products are made with extensive research and field-testing. Every unit is thoroughly inspected and tested prior to shipment.

IMPORTANT SAFETY INSTRUCTIONS

IMPORTANT! Read the following important safety instructions to avoid personal injury or death, and to avoid damage to the equipment or property.

WARNINGS

 The GB8MP-10-LD-U (**only**) is equipped with two (2) power switches and two (2) 120 volt grounded power cords. To avoid any injury, turn both power switches OFF. Or, unplug both power cords and allow unit to cool completely before performing any maintenance or cleaning.

 The GB5MV-10-LD and GB6MP-10-LD-U are equipped with one (1) power switch and one (1) 120 volt grounded power cord.

 Plug units into properly grounded electrical outlets of the correct voltage, size, and plug configuration. The GB8MP-10-LD-U (only) requires two (2) separate dedicated outlets. If the plug and receptacle do not match, contact a qualified electrician to determine the proper voltage and size and install the proper electrical outlets.

 These units have no “user” serviceable parts. To avoid damage to the unit or injury to personnel, use only Authorized Cecilware Service Agents and Genuine Cecilware Parts when service is required.

 Genuine Cecilware Replacement Parts are specified to operate safely in the environment in which they are used. Some aftermarket or generic replacement parts do not have the characteristics that will allow them to operate safely in Cecilware equipment. It is essential to use Cecilware Replacement Parts when repairing Cecilware equipment. Failure to use Cecilware Replacement Parts may subject operators of the equipment to hazardous electrical voltage, resulting in electrical shock or burn.

CAUTIONS

 Place the unit at the proper counter height in an area that is convenient for use. The location should be level to prevent the unit or its contents from accidentally falling, and strong enough to support the weight of the unit and its contents.

 To avoid any injury or damage to the unit do not move or relocate the unit for cleaning.

 Abrasive cleaners could scratch the finish of your unit. Use only mild, non abrasive cleaners.

MODEL DESCRIPTION



GB8MP-10-LD-U (shown) GB5-LD-U & GB6MP-10-LD-U (typical)

These High Volume Cappuccino Dispensers will hold double the amount of your most popular flavor along with up to seven other flavors as well.

With these Dispensers you will not waste valuable time refilling product Hoppers or lose profits during peak sales periods. With the hot water dispense button, you can increase sales by offering the ability to add packet items to your menu as well.

Only Cecilware brings you this type of versatility. With its top hinged and bottom hinged door design, its 27 inch footprint (left to right) allows maximum utilization of counter space.

SPECIFICATIONS

ELECTRICAL RATING CHART

| Model * | Voltage | Watts | Amps | Circuit Breaker | Shipping Weight |
|---------------|-----------|------------|----------|-----------------|-----------------|
| GB5MV-10-LD | 1 x 120 V | 1 x 1800 W | 1 x 15 A | 1 x 15 A | 130 lbs |
| GB6MP-10-LD-U | 1 x 120 V | 1 x 1800 W | 1 x 15 A | 1 x 15 A | 160 lbs |
| GB8MP-10-LD-U | 2 x 120 V | 2 x 1800 W | 2 x 15 A | 2 x 15 A | 180 lbs |

*HOT WATER IS OPTIONAL, ADD "W" TO MODEL NUMBER

PLUG CONFIGURATIONS

The GB8 MODEL is supplied from the factory with two (2) 120 volt electrical cords and plugs installed. Plugs are supplied according to the application as shown in figure # 1.

⚠ WARNING

Plug unit into two (2) properly grounded electrical outlets of the correct voltage, size and plug configuration. If the plugs and receptacles do not match, contact a qualified electrician to determine the proper voltage and size and install the proper electrical outlets.

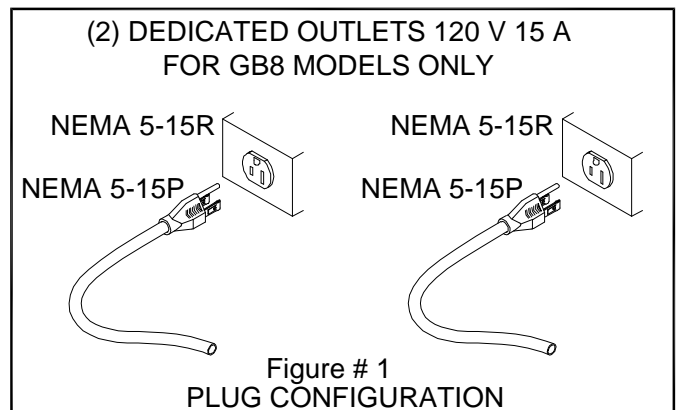

UNPACKING INSTRUCTIONS

Carefully unpack the Cappuccino Dispenser Unit and inspect immediately for shipping damage. Your Cappuccino Dispenser Unit was shipped in a carton designed to give it maximum protection in normal handling. It was thoroughly inspected before leaving the factory. In case of damage, contact the shipper.

DESCRIPTION AND LOCATION OF COMPONENTS

Note: Refer to Illustrations for description and location of COMPONENTS and CONTROLS.

- 1. HOPPERS.** To remove the hoppers simply swing the top compartment door open and lift out. To reposition the canisters in the compartment, slide the canister base back until the ¼" pin at the bottom of the base falls into the positioning hole of the compartment base.
- 2. RINSE SWITCHES.**
See diagrams inside this manual for the location of rinse switches for each individual model. In the **RINSE** position they **disengage the hopper motors** and **allow only water to be dispensed**. They are used for flushing out the Whipper Chambers and to adjust the water dispense valves for proper flow rates.
- 3. HEATER SWITCHES.**
See diagrams inside this manual for the location of heater switches for each individual model. Their primary function is to shut off the heating elements during the initial priming, start up operation of the machine, or whenever the tank is being drained for service.
- 4. POWER SWITCHES.**
See diagrams inside this manual for the location of power switches for each individual model. They control all power to the unit including the heater elements.
Note: The Power and Heater Switches are independent of each other. Both switches must be OFF in order for the unit to be completely shut down.
Note: The Power Switches and Heater Switches must be ON in order for the elements to operate.

INSTALLATION INSTRUCTIONS

WATER INLET CONNECTION:

This equipment is to be installed to comply with the applicable Federal, State, or Local plumbing codes having jurisdiction. In addition:

WATER CONNECTION:

GB8MP-10-LD-U: There are two (2) Water Connections. (2) ¼ inch Flare Water Inlet Fittings are located on the left and right side in the back of unit.

GB5MV-10-LD, & GB6MP-10-LD-U: There is one (1) Water Connection, (1) ¼ inch Flare Water Inlet Fitting located on the back of unit.

An approved back flow prevention device, such as a Double Check Valve should be installed between the unit and the water supply.

HIGHLY RECOMMENDED:

A WATER SHUT-OFF VALVE and A WATER FILTER, preferably a combination Charcoal/Phosphate Filter, to remove odors and inhibit lime and scale build up in the machine.

Note: In areas with extremely hard water, a water softener must be installed in order to prevent malfunctioning of the equipment and in order not to void the warranty.

START-UP PROCEDURE

Caution: Make sure that the Heater Switches, are in the OFF position.

1. Connect the ¼ inch copper waterlines to the ¼ inch flare water inlet fittings of the valves.
2. Plug the power cords into dedicated receptacles.
3. Activate the **Power Switch** (Toggle Up). The door display panel, the red power indicator lights and the green dispense buttons will light up and the tanks will start filling. Allow approximately 4-5 minutes for the tanks to fill.
4. Activate the **Heater Switch**. Allow approximately 10-30 minutes for the water to reach the proper dispensing temperature of 190° F. The heat up time will depend on the water inlet temperature, the input voltage and the wattage of the elements in the water tanks.
5. Place a cup under the dispense nozzle, press and hold the dispense switch for 6 seconds. The unit will dispense water at the rate of 1 oz. per second. Repeat it several times to check for consistent output. Repeat same for the other dispense switches. This procedure checks that the dispense valves are not “air-locked.”
6. While the water tanks are heating up, the **heater light** comes on. Remove the hoppers, load them with product and reposition them back in place. When the **heater light** turns off, the water tanks have reached their proper temperature and are ready to dispense the first cup of Cappuccino.

TO DISPENSE A CUP OF CAPPUCCINO:

Place a cup under the selected drink dispense nozzle.

Push and hold dispense button until cup is 2/3 full, then release button.

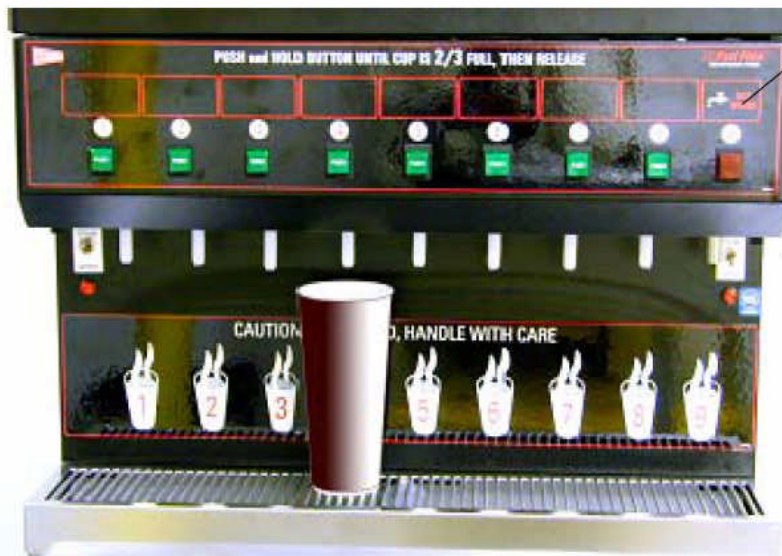

Hot Water Option
GB6MP-10W-LD-U
GB8MP-10W-LD-U

TROUBLESHOOTING GUIDE

WARNING: To reduce the risk of electrical shock, DISCONNECT POWER CORDS before repairing or replacing any internal components of the unit. Before any attempt to replace a component be sure to check all electrical connections for *proper connection*.

| PROBLEM | | PROBABLE CAUSE | REMEDY |
|--|---|---|--|
| 1 Light display not lit. | A | Dispensing unit unplugged. | Reconnect dispensing unit. |
| | B | No power from Terminal Block. | Check the Terminal Block for loose wire. |
| | C | Defective Bulb. | Replace Bulb. |
| | D | Defective Ballast. | Replace Ballast. |
| | E | Loose Bulb in socket. | Make sure bulb is seated properly in socket. |
| 2 No water when Rinse Switch is ON. | A | Water supply OFF. | Turn water ON. |
| | B | Clogged inlet screen (Water Inlet Valve). | Disconnect water line and clean inlet screen. |
| | C | Inoperative Water Inlet Valve. | Check connection, if needed replace Valve. |
| | D | Loose electrical connection. | Check all electrical connections. |
| 3 No product when Dispense Button is pressed | A | No product in Canister. | Add product. |
| | B | Auger not working. | Engage Hopper/Nut to Motor Gear. |
| | C | Damaged, loose, or missing Agitator Gear. | Replace Agitator Gear. |
| | D | Inoperative Auger Motor or Relay. | Check connections of Motor, Relay and/or Switch, if needed replace components. |
| | E | Canister outlet clogged. | Clean Hopper. |
| | F | Faulty Coupling. | Replace damaged Coupling components. |
| 4 Water does not shut off. Water keeps dispensing. | A | Leaking Water Inlet Valve. | Clean/check Water Inlet Valve fittings. Replace Water Inlet Valve if needed. |
| | B | Inoperative Dispense Switch. | Check Switch connections. Replace Dispense Switch if needed. |
| | C | Inoperative Rinse Switch. | Check Rinse Switch connections. Replace Rinse Switch if inoperative. |
| | D | Clogged/stuck Water Dispense Valve. | Clean or unclog Water Dispense Valve. Replace Dispense Valve if inoperative. |
| 5 No water is going into tank at all. | A | Water Inlet Valve malfunction. | Check Solenoid. Replace if necessary. |
| | B | Dual Probe malfunction. | Check Probe. Replace if necessary. |
| | C | Dual Probe Liquid Level Controller malfunction. | Check Controller. Replace if necessary. |
| 6 Water will not stop flowing into water tank. | A | Dual Probe malfunction. | Check Probe. Replace if necessary. |
| | B | Solenoid (Water Inlet Valve) malfunction. | Check Solenoid. Replace if necessary. |
| | C | Dual Probe Liquid Level Controller malfunction. | Check Controller. Replace if necessary. |
| 7 Water is not heating up in water tank. | A | Heater Switch is OFF. | Turn Heater Switch ON. |
| | B | Thermostat is OFF. | Turn Thermostat ON. |
| | C | Loose connection on Thermostat. | Make sure all wires and terminals on Thermostat are tight. |
| | D | Hi-Limit Temperature Switch is defective | Replace the Hi-limit switch. |
| | E | Heater is burned out or defective. | Replace the Heater. |

Model L690A (Rev. B) Dual Probe Liquid Level Controller

Overview - The L690A is a Dual Probe Liquid Level Controller designed to maintain a specific level of water in the tank. This device utilizes two level probes for increased reliability. Independent maximum fill timers are incorporated in the controller for overflow protection.

Operation - When a fill problem occurs, the Dual Probe Liquid Level Controller turns OFF power to the fill valves and remains OFF until the power input is reset (i.e. turn power switch off then back on).

Low Level Probe - When the Low Level Probe detects the absence of water for two seconds, the Controller immediately opens the Fill Valve. When the Low Level Probe detects the presence of water the Controller immediately closes the Fill Valve.

High Level Probe - When the High Level Probe detects the absence of water the Controller immediately turns ON and the Low Level Probe is allowed to control the Fill Valve. When the High Level Probe detects the presence of water for 1.5 seconds the Controller turns OFF power, which closes the Fill Valve.

Maximum Fill Timers – On the first fill, the unit will only allow 15 minutes of continuous filling if neither of the Level Probes has detected the presence of water since power has been applied (i.e. first fill). Once the presence of water has been detected the unit will only allow 10 minutes of continuous filling to prevent flooding. If the duration of continuous filling exceeds the allotted time then a Fatal Error is generated, which closes the inlet valve.

Status LED – Located on the Controller, this indicator is turned ON for one second after power is applied to indicate a functioning unit. The indicator will blink when the High Level Probe detects water to signify a warning. During a Fatal Error the indicator will be ON continuously.

RECOMMENDED CLEANING, SANITIZING, REFILLING AND MAINTENANCE

PERIODIC MAINTENANCE:

1. ROTATE PRODUCT GUIDES UP, REMOVE HOPPERS AND REFILL WITH PRODUCT.
2. REPLACE HOPPERS, ROTATE PRODUCT GUIDES DOWN.
3. EMPTY DRIP TRAY.
4. SANITIZE* ALL EXTERIOR SURFACES.

WEEKLY MAINTENANCE:

1. PRODUCT HOPPER CLEANING
 - ROTATE PRODUCT GUIDES UP, REMOVE HOPPERS FROM MACHINE.
 - EMPTY POWDER INTO PANS.
 - PULL OFF PRODUCT GUIDES.
 - REMOVE AGITATOR WHEELS.
 - UNSCREW AND REMOVE FRONT AND BACK AUGER LOCKS.
 - REMOVE AUGER.
 - WASH, RINSE, SANITIZE*, AND AIR DRY ALL SMALL PARTS.
 - WASH & SCRUB HOPPERS AND AGITATOR WHEEL RECESSES WITH BRISTLE BRUSH
 - REASSEMBLE ALL HOPPERS.
 - POUR POWDER INTO HOPPERS.
 - INSTALL ALL HOPPERS INTO UNIT.
2. WHIPPER CHAMBER CLEANING
 - REMOVE DISPENSE CAPS BY TURNING AND LIFTING.
 - REMOVE MIXING BOWLS BY LIFTING AND PULLING.
 - REMOVE PRODUCT TUBES BY PULLING DOWN.
 - TWIST OFF WHIPPING CHAMBERS CLOCKWISE.
 - PULL OFF WHIPPER BLADES.
 - TWIST OFF WHIPPER CHAMBER MOUNTS CLOCKWISE.
 - REMOVE O-RINGS.
 - REMOVE TRAY BY PULLING LEVERS DOWN.
 - REMOVE BOTH POWDER TRAYS BY PULLING LEVERS OUT.
 - WASH, RINSE, AND SANITIZE SMALL PARTS AND INTERIOR MACHINE SURFACES.
 - REASSEMBLE ALL SMALL PARTS.

DAILY MAINTENANCE:

1. RINSE WHIPPER CHAMBERS
 - POSITION PAN UNDER DISPENSE TUBES.
 - MOVE RINSE SWITCH TO "RINSE".
 - PUSH AND HOLD EACH DISPENSE BUTTON 3 TO 5 SEC.
 - MOVE RINSE SWITCH TO "SERVE".
2. EMPTY DRIP TRAY WASH, RINSE, AND SANITIZE*

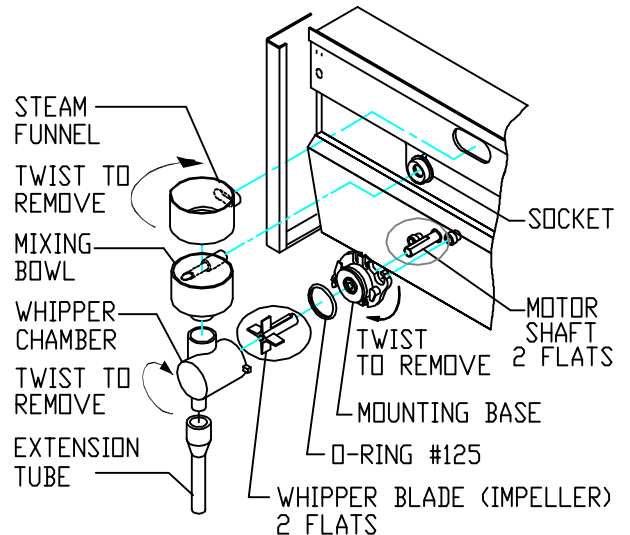
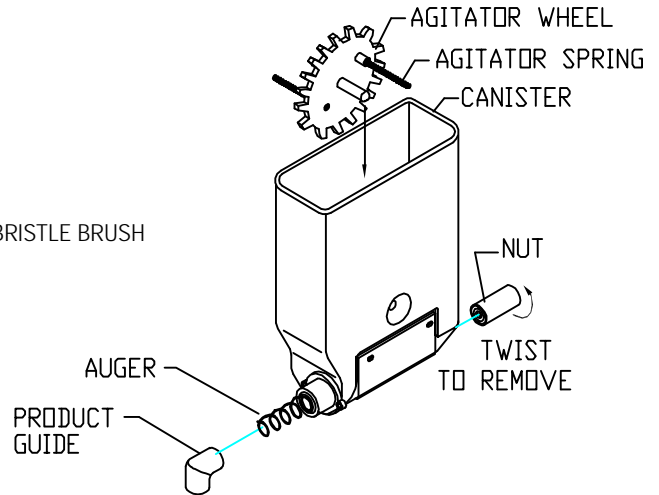

NOTE:

WHEN REASSEMBLING, ALIGN FLAT KEYWAY INSIDE BLADE WITH FLAT KEYWAY OF MOTOR SHAFT. PUSH THE WHIPPER BLADE ALL THE WAY ON

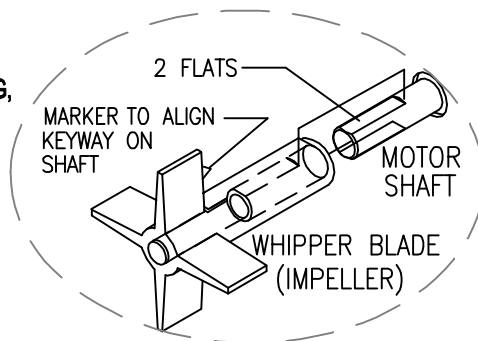

*** SANITIZING:**

All sanitizing agents in the food zone must comply with 21 CFR 178.1010.

All food dispensing units should be sanitized periodically. All parts to be sanitized must be cleaned first.

To prepare a sanitizing solution:

ADD 2 TSP. OF LIQUID CLOROX BLEACH (5.25% CONCENTRATION) TO 1 GALLON OF WATER AT ROOM TEMPERATURE (70° - 90°F).

Note: Always start with a unopened bottle of Clorox Bleach since the solution from an opened bottle has a short life span.

- Soak all parts for a minimum of 3 min. in the sanitizing solution.
- Let all sanitized parts drain and dry naturally. DO NOT WIPE THEM DRY.
- Before using the sanitized unit (or parts) with food stuffs, rinse all parts thoroughly with water.

COMPONENT TESTS

A) Thermostat Adjustments:

The Thermostat is factory set for proper dispense temperature of 190° F with the control shaft set to the maximum clockwise position. If field adjustments are needed proceed as follows:

To **DECREASE** temperature, turn the control shaft slightly in the **COUNTERCLOCKWISE** direction.

For qualified technicians ONLY:

Remove the knob and locate the Slotted Adjustment Screw inside the hollow thermostat shaft. Using a narrow-bladed screwdriver, engage slotted adjustment screw and turn it ¼ turn very slowly counterclockwise (CCW). Allow a few minutes for the temperature to reach set level. The Heater Light will go ON, indicating the heating element is activated, wait for it to go OFF, indicating that the water has reached NEW set temperature. Take a temperature reading and repeat if necessary.

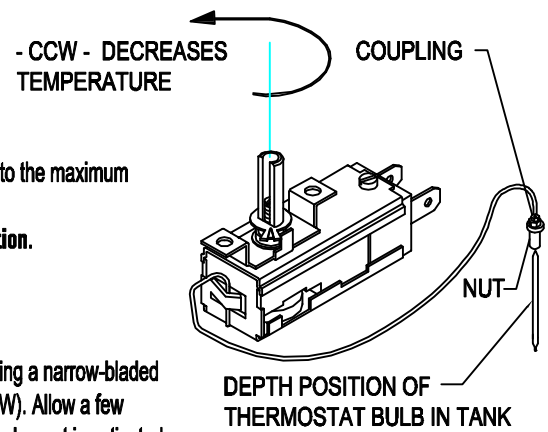

B) Water Inlet Valve Test

Turn power OFF. If the water level rises inside a partially filled tank, the Water Inlet Valve is leaking. Disconnect wires from the Water Inlet Valve coil and connect a 2 wire line cord to the terminals. Plug it into a 115V outlet. If water flows in and stops when you pull it out, the Valve is working fine. Repeat this test a few times. The problem may be in the Probe or Water Level Control Board. If the water does not flow in when the cord is plugged into an electrical outlet, the Solenoid coil may be damaged, opened or the valve may have an obstruction preventing the water from flowing in. Clean or replace it.

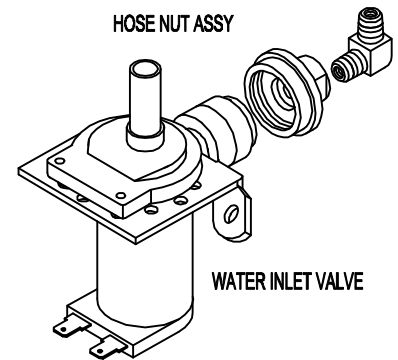

C) Dual Probe Test

If lack of water persists, check the probe as follows:

Turn on the power and water supply. Check inside the tank to make sure the water is below the Probe. Pull the BLUE wire and terminal OFF the Probe rod. If water still does not flow after the wire is disconnected from the Probe, the problem may be in the Solid State Dual Level Control Board. If water starts flowing into the tank, the Probe may be grounded, due to excessive liming. Check with Ohm meter. Clean or replace probe.

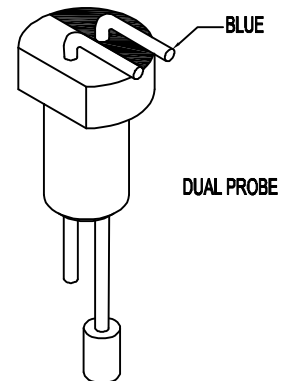

D) Dual Probe Liquid Level Controller Test

Check the Controller as follows:

1. Make sure there is power input to the Controller at the terminals AC1 & AC2
Your voltmeter should read 115 Volts. It should read the same at terminals AC1 & FILL when the water level is low. This is the output power to actuate the coil of the Solenoid Valve to open it. The lack of voltage at terminals AC1 & L-LEVEL or H-LEVEL indicates that the Controller is not working properly.
2. Make sure all wire connections are tight, including ground.
3. If after this, the Controller is still failing to open the Water Inlet Valve, replace it.

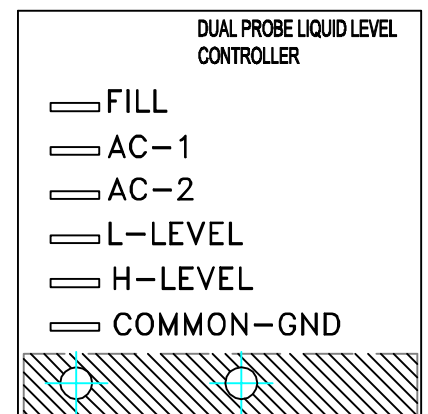

GB5MV-10-LD (VISTA)

5 Flavor Cappuccino Dispenser

Door not shown

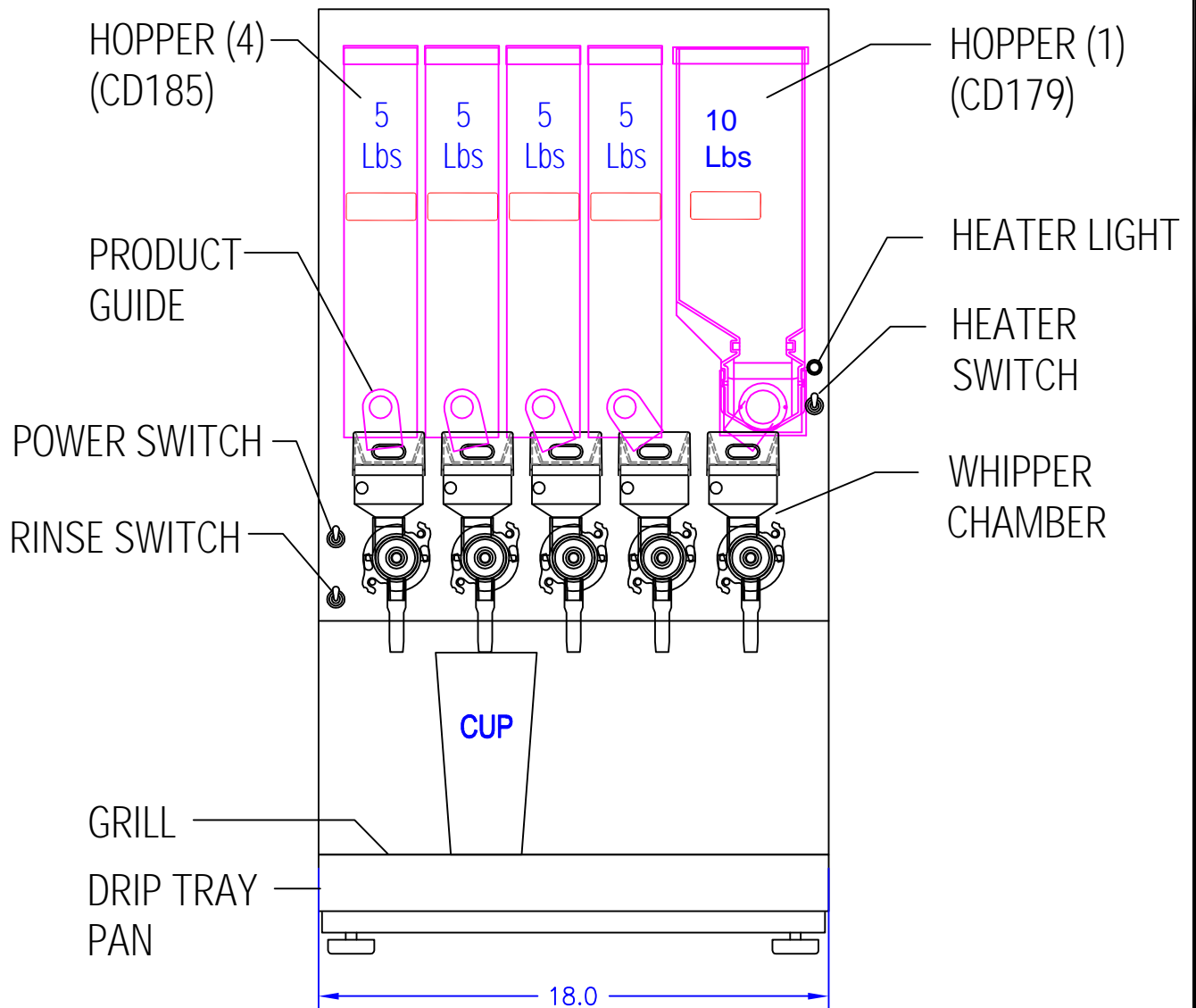

GB6M-10-LD-U
GB6MP-10-LD-U

6 Flavor Cappuccino Dispenser
Upper Door open, Lower Door not shown.

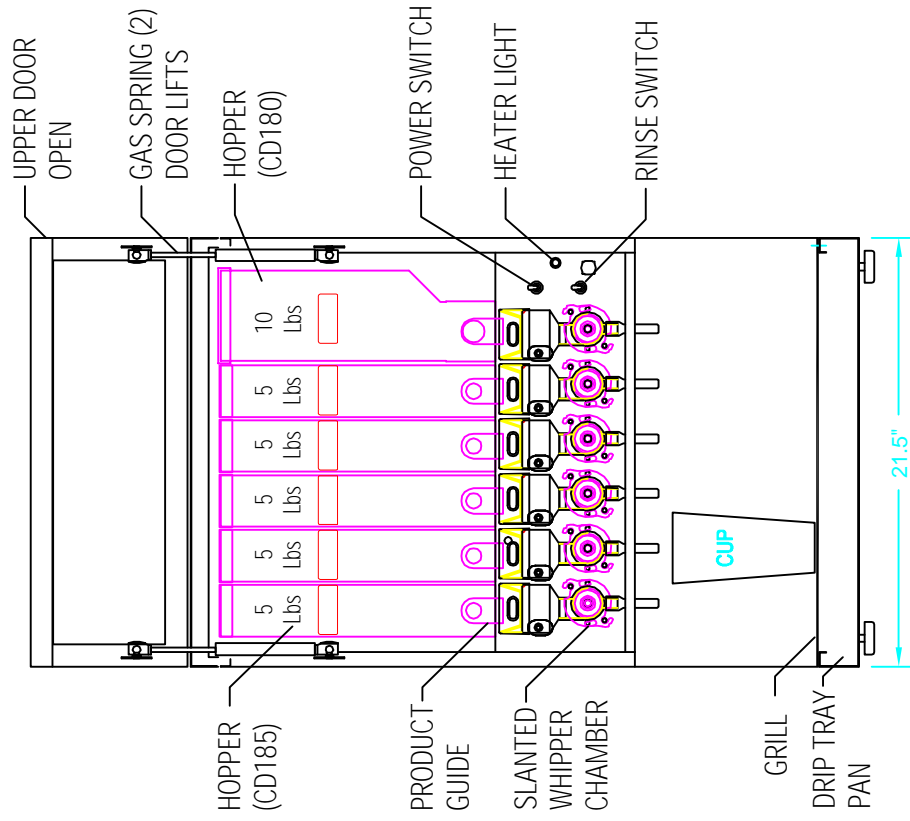

GB8M-10-LD-U
GB8MP-10-LD-U

8 Flavor Cappuccino Dispenser
Upper Door open, Lower Door not shown.

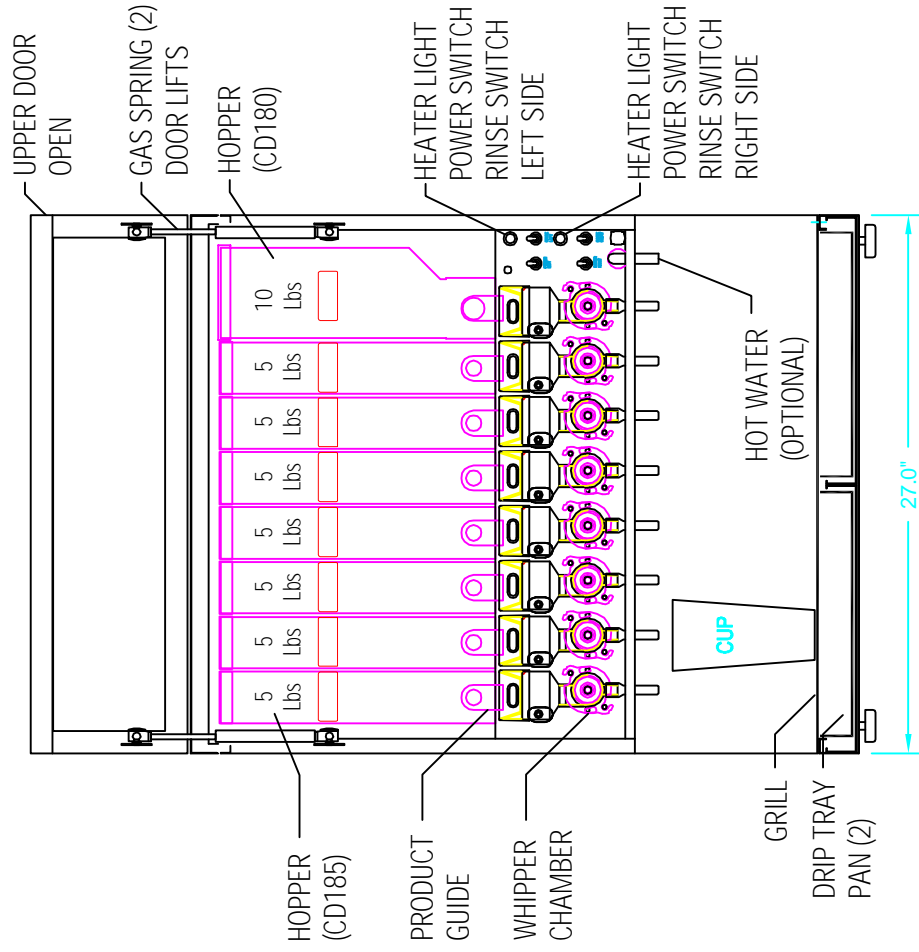

WHIPPER CHAMBER

IMPORTANT:

SLANTED WHIPPER CHAMBERS (SEE BELOW) ARE **NOT** INTERCHANGEABLE WITH STANDARD **STRAIGHT** WHIPPER CHAMBERS. BE SURE TO ORDER USING THE CORRECT PART NUMBERS.

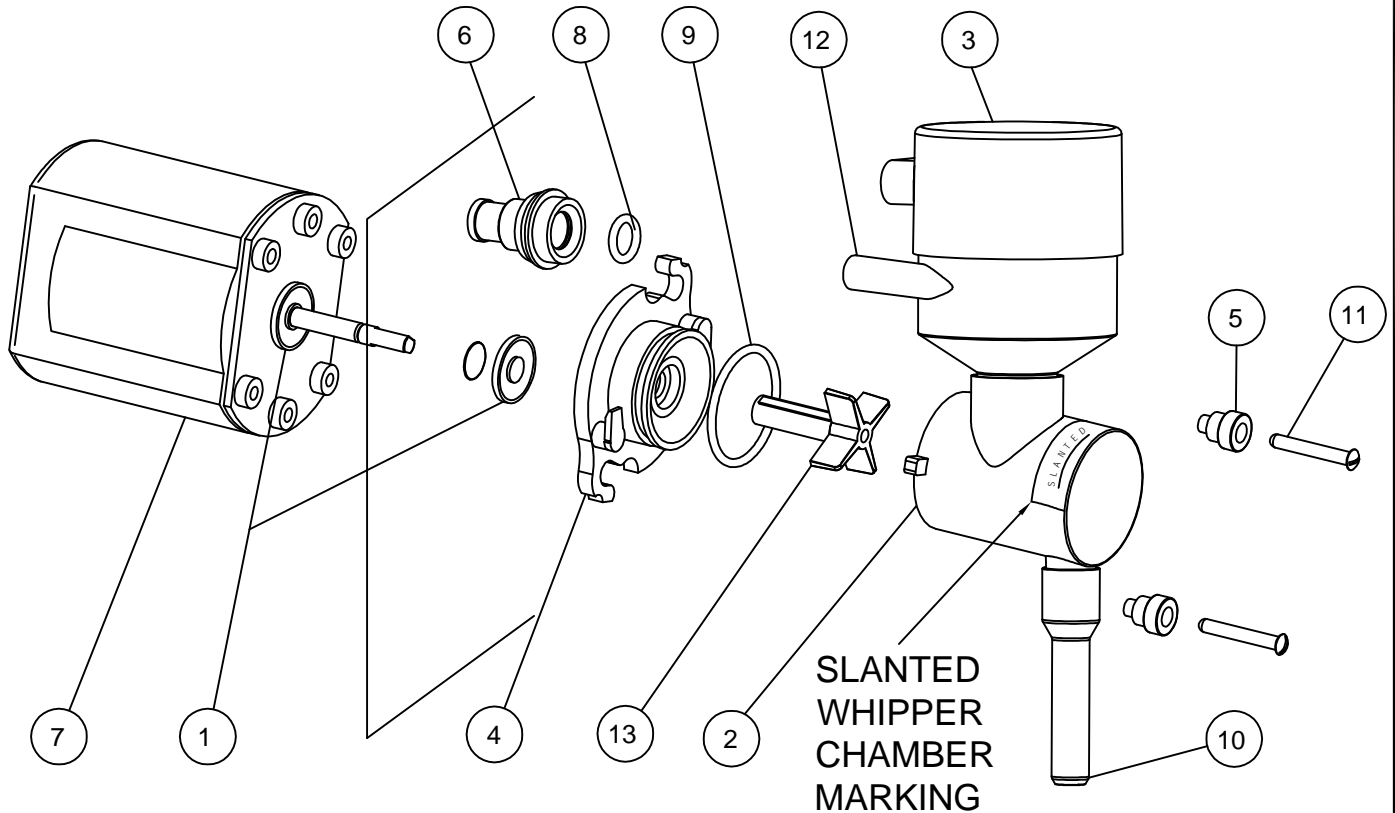

Parts List

| ITEM | DESCRIPTION | PART # | QTY |
|------|---|--------|-----|
| 1 | SLINGER DISK | CD124 | 2 |
| 2 | WHIPPER CHAMBER - STANDARD (STRAIGHT) | CD63A | 1 |
| 2 | WHIPPER CHAMBER - SLANTED (NEW) | CD362 | 1 |
| 3 | DISPENSE CUP | CD61A | 1 |
| 4 | CHAMBER MOUNT | CD65A | 1 |
| 5 | GROMMET, MTG.PLATE | CD66A | 2 |
| 6 | SOCKET, MIXING BOWL | CD67A | 1 |
| 7 | WHIPPER MOTOR (OLD) 1 FLAT | CD75A | 1 |
| 7 | WHIPPER MOTOR (NEW) 2 FLATS (REPLACES CD75A) | CD350 | 1 |
| 8 | "O" RING | M378A | 1 |
| 9 | "O" RING | M379A | 1 |
| 10 | EXTENSION TUBE, NYLON, 2 5/8" LONG | M467A | 1 |
| 11 | MACH. SCREW 8-32 X 1.25" SL TR HEAD ST. STEEL | P619A | 2 |
| 12 | MIXING CHAMBER | CD137 | 1 |
| 13 | IMPELLER (1 FLAT) USE W/ CD75A) | CD64A | 1 |
| 13 | IMPELLER (2 FLATS) USE W/ CD75A OR CD350 | CD353 | 1 |

HOPPER ASS'Y CD185

5 LB, 14"HIGH x 2.5"WIDE, W/ WIRE AUGER

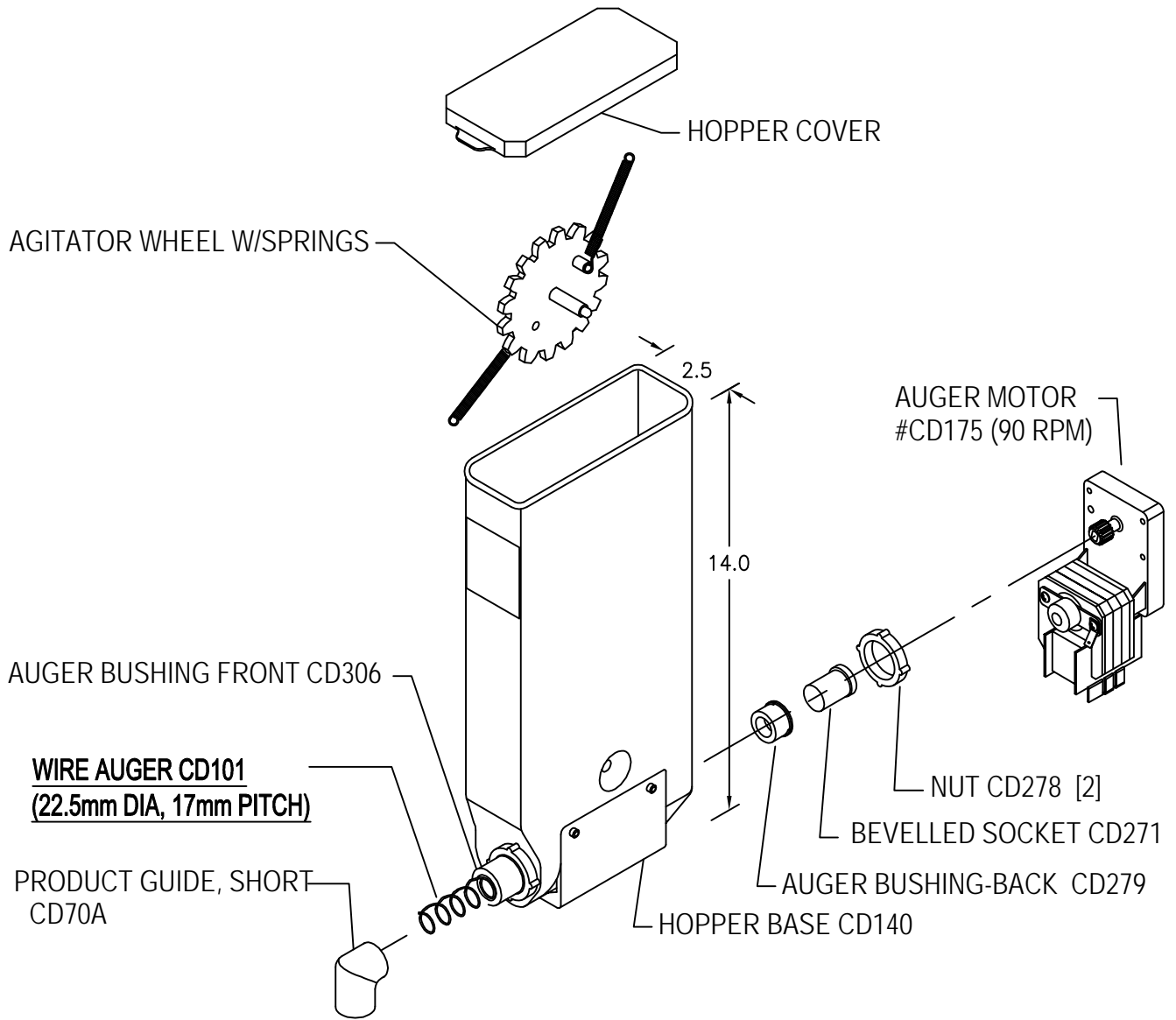

HOPPER ASS'Y CD180 - RIGHT (SHOWN BELOW)
HOPPER ASS'Y CD179 - LEFT (OPPOSITE)
10 LB, 14"HIGH x 4.5"WIDE, W/ WIRE AUGER

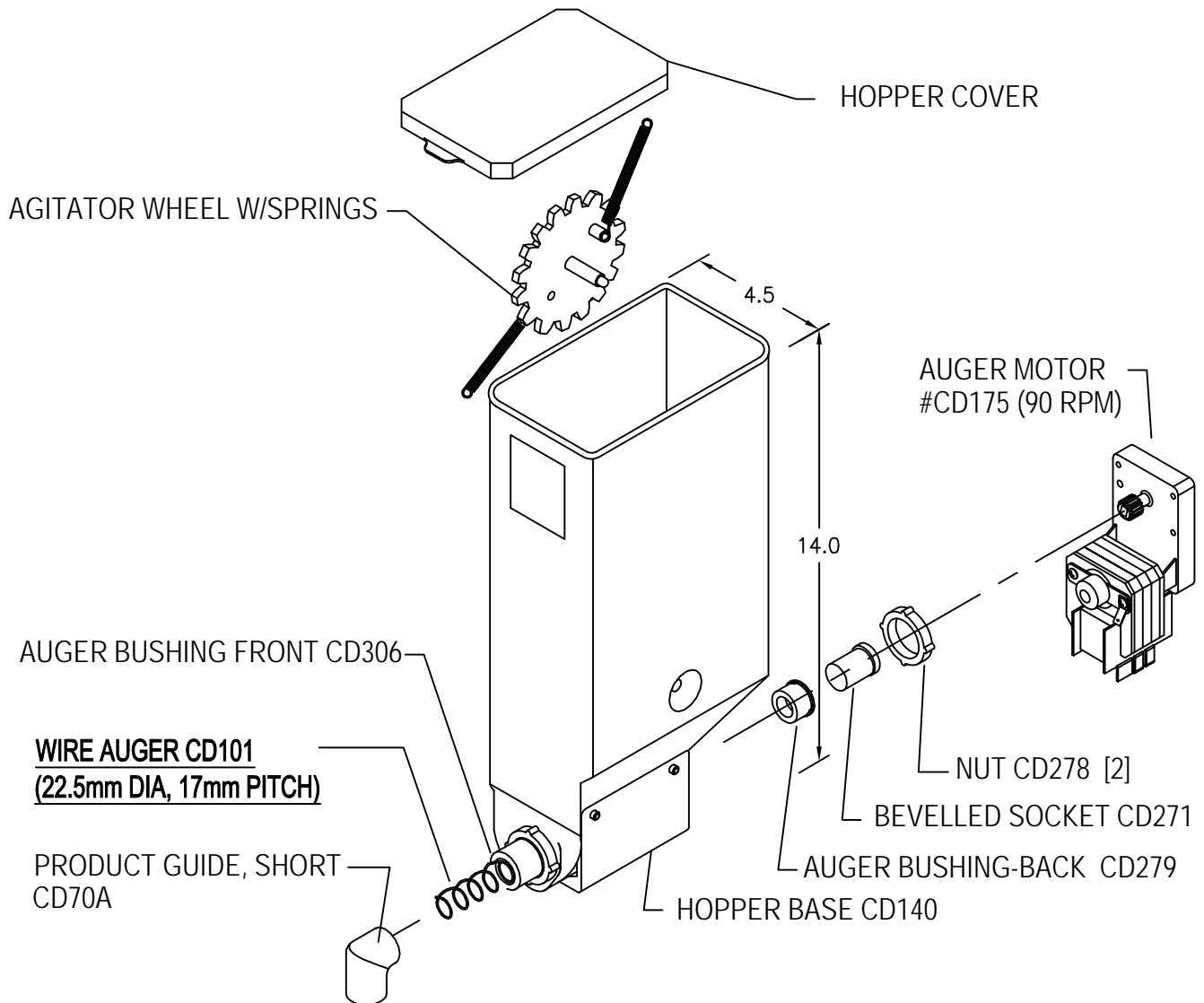

BODY ASS'Y
GB5MV-10-LD (Vista)

PARTS LIST

| ITEM | DESCRIPTION | P/N | QTY |
|------|-------------------------------------|-------|-----|
| 1 | BODY FRAME SUB-ASSEMBLY (REFERENCE) | | |
| 2 | SIDE PANELS | RG48A | 2 |
| 3 | WATER INLET VALVE | L462A | 1 |
| 4 | HOSE NUT ASSEMBLY | K491A | 1 |
| 5 | POWER CORD | CF82A | 1 |
| 6 | HOPPER GUIDE | SL30A | 5 |
| 7 | HOPPER TRAY | ST94A | 1 |
| 8 | TROUGH | ST95A | 1 |
| 9 | TROUGH DRAWER | ST96A | 1 |
| 10 | FACIA BOTTOM CAP | SD85A | 1 |
| 11 | SWELL LATCH | M650A | 4 |
| 12 | MOLDED BACKSPASH | M989A | 1 |
| 13 | POWER SWITCH/ HEATER SWITCH | L069A | 2 |
| 14 | RINSE/ SERVE SWITCH | L567A | 1 |
| 15 | GRILL FOR MOLDED TRAY | SU17A | 1 |
| 16 | MOLDED DRIP TRAY | M980A | 1 |
| 17 | PLASTIC TOP | M988A | 1 |
| 18 | HEATER LIGHT | C002A | 1 |

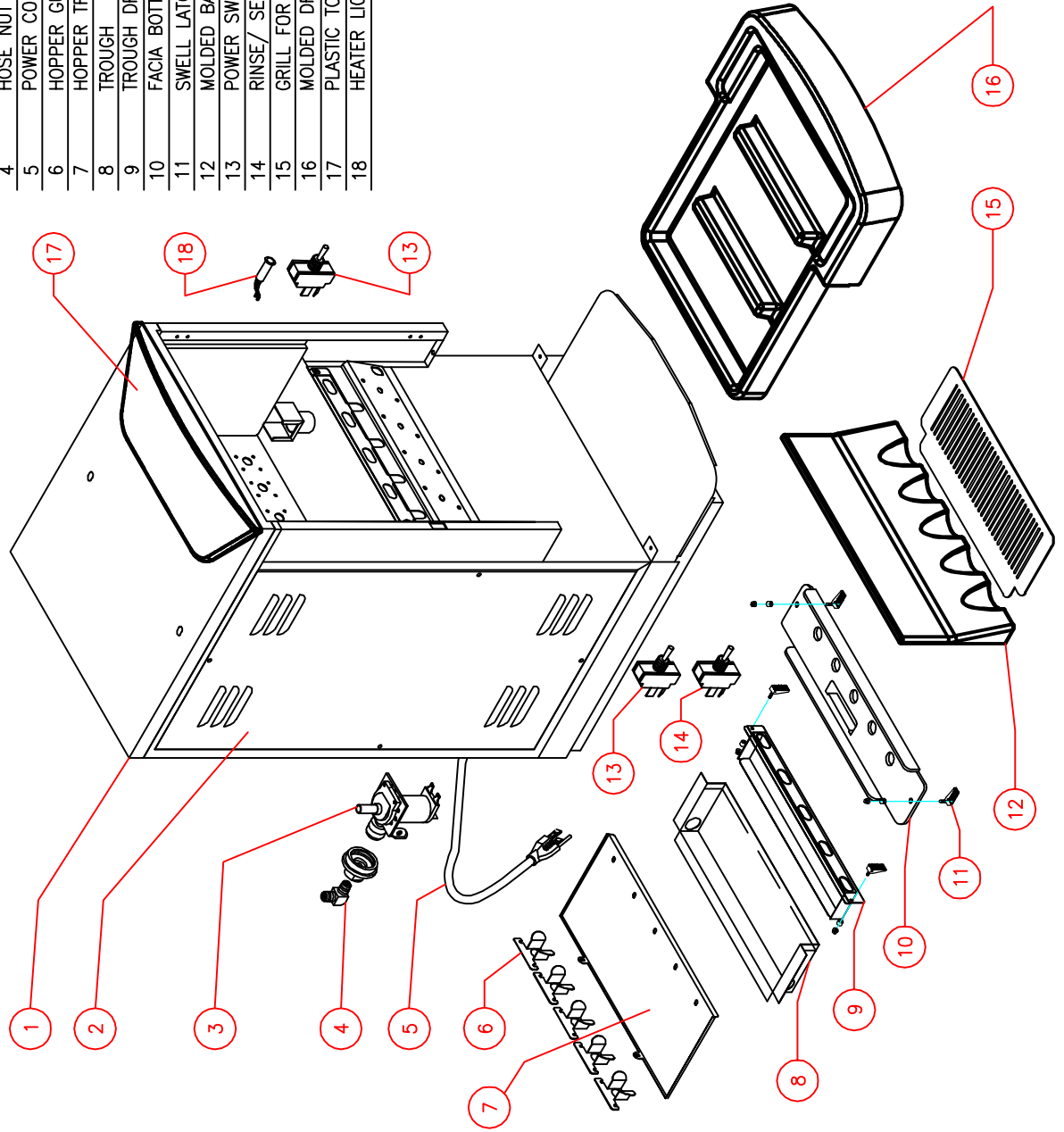

**DOOR ASS'Y
GB5MV-10-LD (Vista)**

PARTS LIST

| ITEM | DESCRIPTION | P/N | QTY |
|------|---------------------------------|-------|-----|
| 1 | MOLDED DOOR (VISTA) | M976A | 1 |
| 2 | DURATRAN (SIZE SPEC.) | NN21A | REF |
| 3 | DURATRAN RETAINER | MA06A | 1 |
| 4 | DOOR LATCH, SLAM ACTION | M705A | 1 |
| 5 | NUT PLATE, LATCH | SD08A | 1 |
| 6 | DOOR HOUSING | SU18A | 1 |
| 7 | INSIDE DOOR PANEL | SU19A | 2 |
| 8 | SWITCH, PUSH BUTTON - GREEN | L455A | 5 |
| 9 | WINDOW COVER FOR MOLDED DOOR | SV55A | 1 |
| 10 | TIE WRAP | M981A | 2 |
| 11 | LAMP HOLDER, PORCELAIN | B216A | 2 |
| 12 | "O" RING, SILICONE | CB04A | 2 |
| 13 | BULB, FLUORESCENT 18W TWIN TUBE | CE82A | 2 |

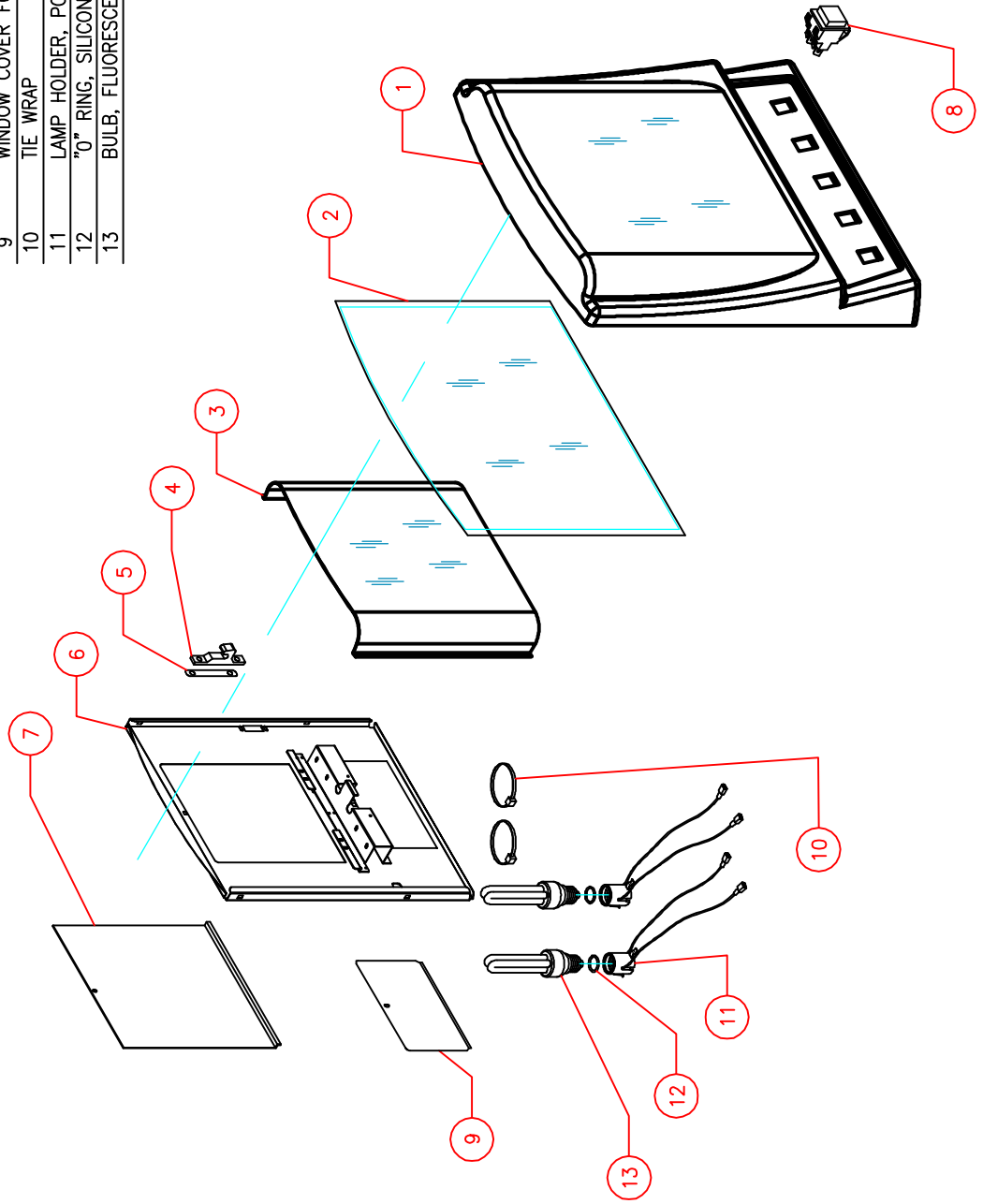

BODY ASS'Y

GB6MP-10-LD-U (Panorama)
GB8MP-10-LD-U (Panorama)

PARTS LIST

| ITEM NO. | GB6MP P/N | QTY | GB8MP P/N | QTY | DESCRIPTION OF COMPONENTS FOR MACHINES WITH MOLDED FRONT GB6MP AND GB8MP |
|----------|-----------|-----|-----------|-----|--|
| 1 | SM15A | 1 | SL96A | 1 | TOP COVER, REAR |
| 2 | SM16A | 1 | SL97A | 1 | TOP COVER, FRONT |
| 3 | SQ77A | 1 | SQ67A | 1 | REMOVABLE HOPPER BASE PANEL |
| 4 | ST88Q | 1 | SQ64Q | 1 | BODY ASSEMBLY |
| 5 | SL76A | 2 | SL76A | 2 | SIDE PANELS |
| 6 | L069A | 1 | L069A | 2 | HEATER SWITCH (SAME AS POWER SWITCH) |
| 7 | K491A | 1 | K491A | 2 | WATER INLET CONNECTOR |
| 8 | M897Q | 1 | M897Q | 2 | WATER INLET FITTING ASSEMBLY |
| 9 | L462A | 1 | L462A | 2 | WATER INLET VALVE, S30, 120 V [C223A F/240V] |
| 10 | C032A | 1 | C032A | 2 | POWER CORD 120V, 15AMP [C099A F/240V] |
| 11 | SQ78A | 1 | SQ67A | 1 | REMOVABLE HOPPER BASE PANEL |
| 12 | SQ79A | 1 | SQ68A | 1 | HOPPER DRAWER HOUSING |
| 13 | SQ81Q | 1 | SQ69Q | 1 | HOPPER DRAWER - LEFT |
| | | | SQ70Q | 1 | HOPPER DRAWER - RIGHT |
| 14 | SM48A | 1 | SM37A | 1 | BOTTOM FACIA |
| 15 | M992A | 1 | MA21A | 1 | MOLDED SPLASH GUARD |
| 16 | SU11A | 1 | SK65A | 1 | GRILL FOR MOLDED DRIP TRAY |
| 17 | M982A | 1 | MA22A | 1 | MOLDED DRIP TRAY |
| 18 | CO02A | 1 | CO02A | 2 | HEATER INDICATOR LIGHT |
| 19 | L470A | 1 | L470A | 2 | RINSE SWITCH, TOGGLE, 4 POLE |
| 20 | L069A | 1 | L069A | 2 | POWER SWITCH (same as Heater sw.) [L299A f/240V] |
| 21 | CH139 | 1 | CH139 | 1 | POWER CUT OFF SWITCH ON DOOR - SW. ASSY |
| 22 | M705A | 4 | M705A | 4 | HIDDEN DOOR LATCH (UPPER & LOWER DOOR) |
| | P542A | 4 | P542A | 4 | SCREW, TRUSS HD 8 32 x 5/8 ST. ST. |
| 23 | SL30A | 6 | SL30A | 8 | HOPPER GUIDE |
| 24 | P599A | 2 | P641A | 2 | GAS SPRING, 20 LBS OR 30 LBS [F/GAS SPRING] |
| | A4054 | 2 | A4054 | 2 | SCREW, S.S. 8 32x3/8 TRUSS HD [F/GAS SPRING] |
| | P011A | 2 | P011A | 2 | CAP NUT 8 32 BRASS N.P. [F/GAS SPRING] |

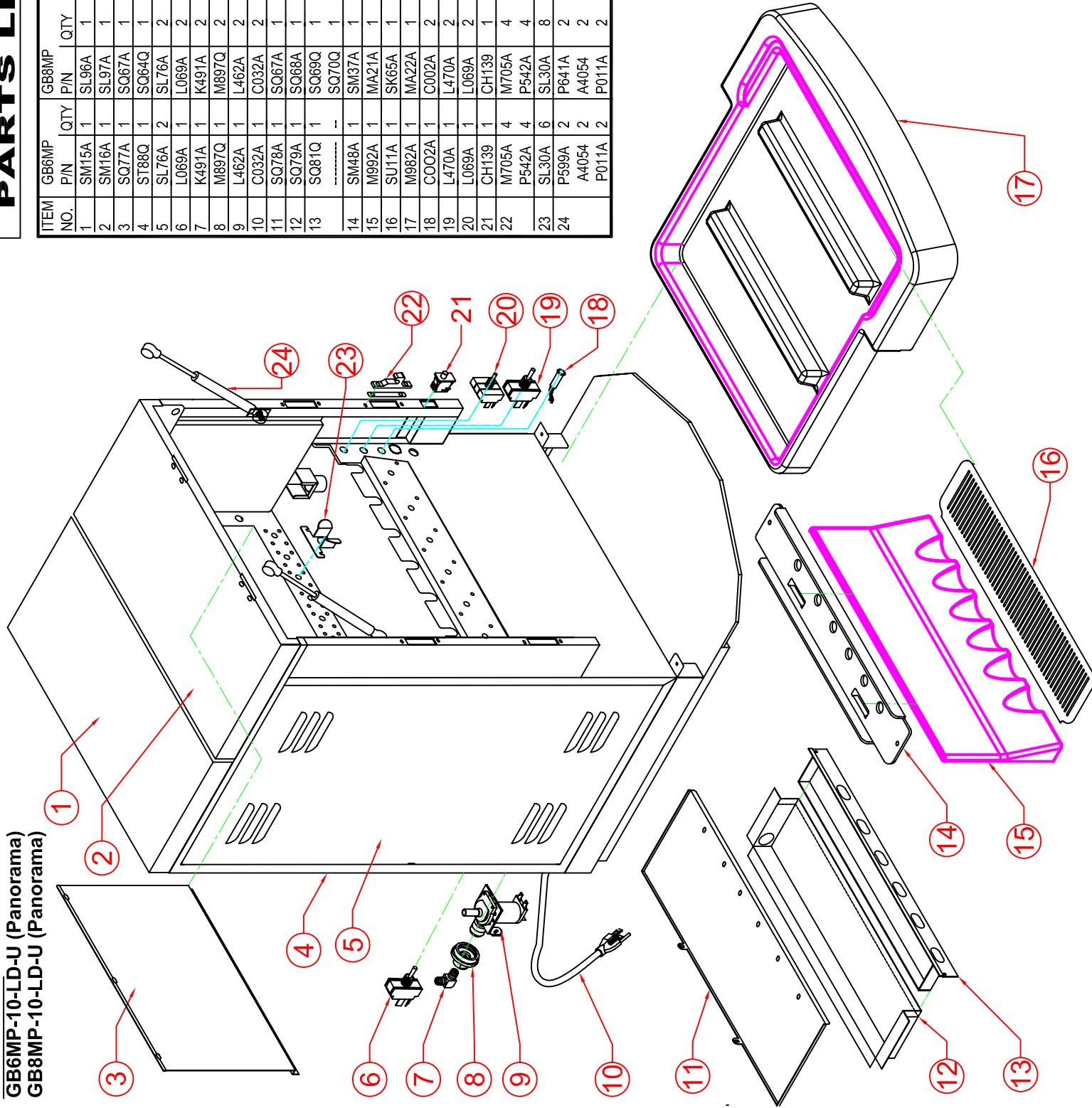

PARTS LIST

| ITEM NO. | GB6MP | | GB8MP | | DESCRIPTION OF COMPONENTS FOR MACHINES WITH MOLDED FRONT GB6MP AND GB8MP |
|----------|-------|-----|-------|-----|--|
| | P/N | QTY | P/N | QTY | |
| 1 | SK61A | 1 | SK43A | 1 | INSIDE DOOR PANEL, UPPER DOOR |
| 2 | SK65A | 1 | SK45A | 1 | INSIDE DOOR PANEL, LOWER DOOR |
| 3 | SK60A | 1 | SK42A | 1 | DOOR HOUSING, UPPER |
| 4 | SK50A | 1 | SK44A | 1 | DOOR HOUSING, LOWER |
| 5 | M903A | 1 | M915A | 1 | MOLDED UPPER DOOR PANEL |
| 6 | M904A | 1 | M916A | 1 | MOLDED LOWER DOOR PA NEL |
| 7 | NN13A | 1 | NN52A | 1 | SWITCH PANEL LABEL F7/MOLDED LOWER DOOR |
| 8 | L455A | 6 | L455A | 8 | DISPENSE SWITCH [GREEN] |
| 9 | MA05A | 1 | MA26A | 1 | CLEAR WINDOW/PANEL 0.04" THICK |
| 10 | M981A | 2 | M981A | 3 | TY-WRAP |
| 11 | B216A | 2 | B216A | 3 | LAMP HOLDER FOR UNIFIED BULB |
| | CE82A | 2 | CE80A | 3 | BULB UNIFIED 120V [CE80A 240V] |

DOOR ASS'Y
 GB6MP-10-LD-U (Panorama)
 GB8MP-10-LD-U (Panorama)

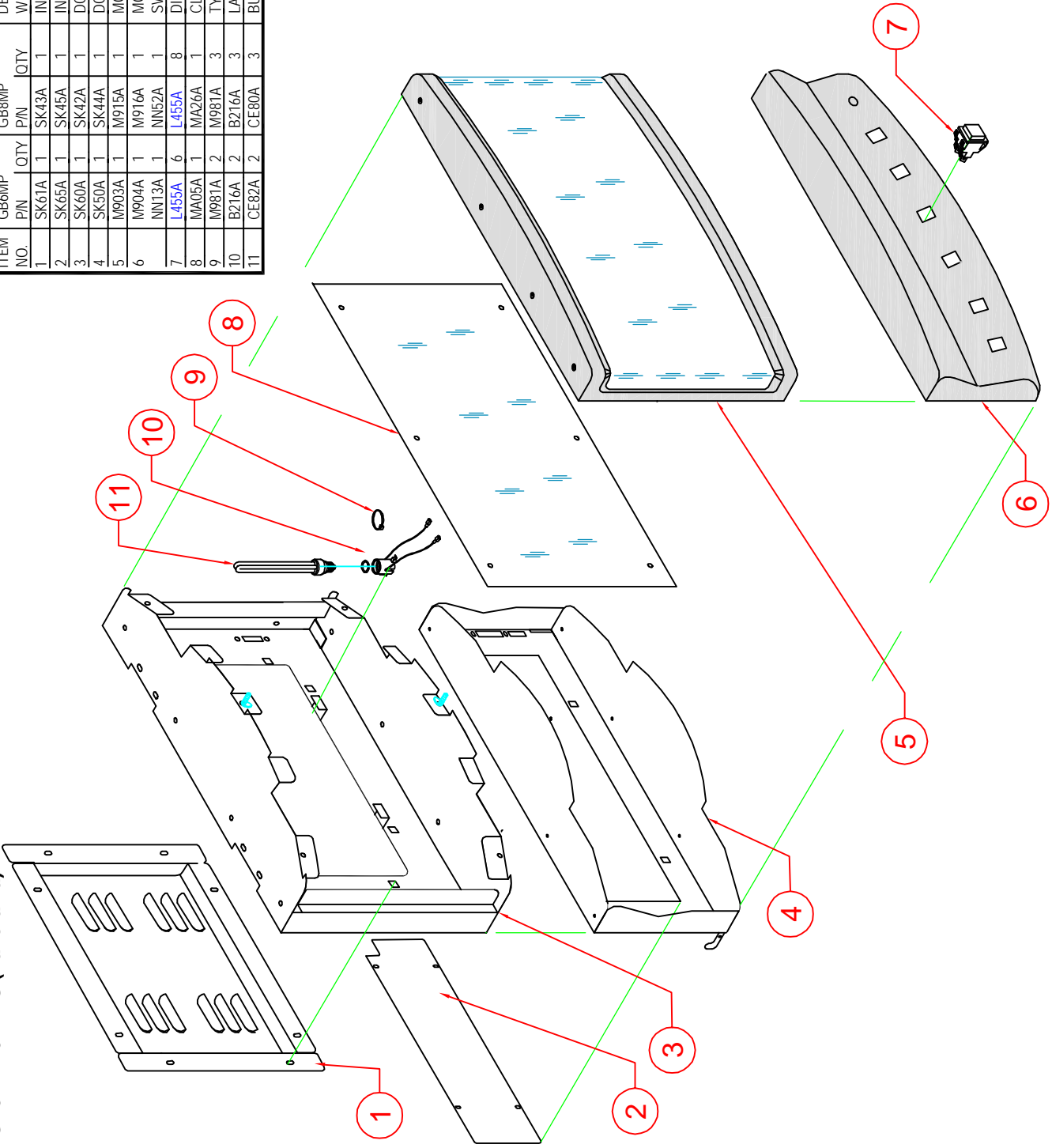

ELECTRICAL CHASSIS AND CONTROL

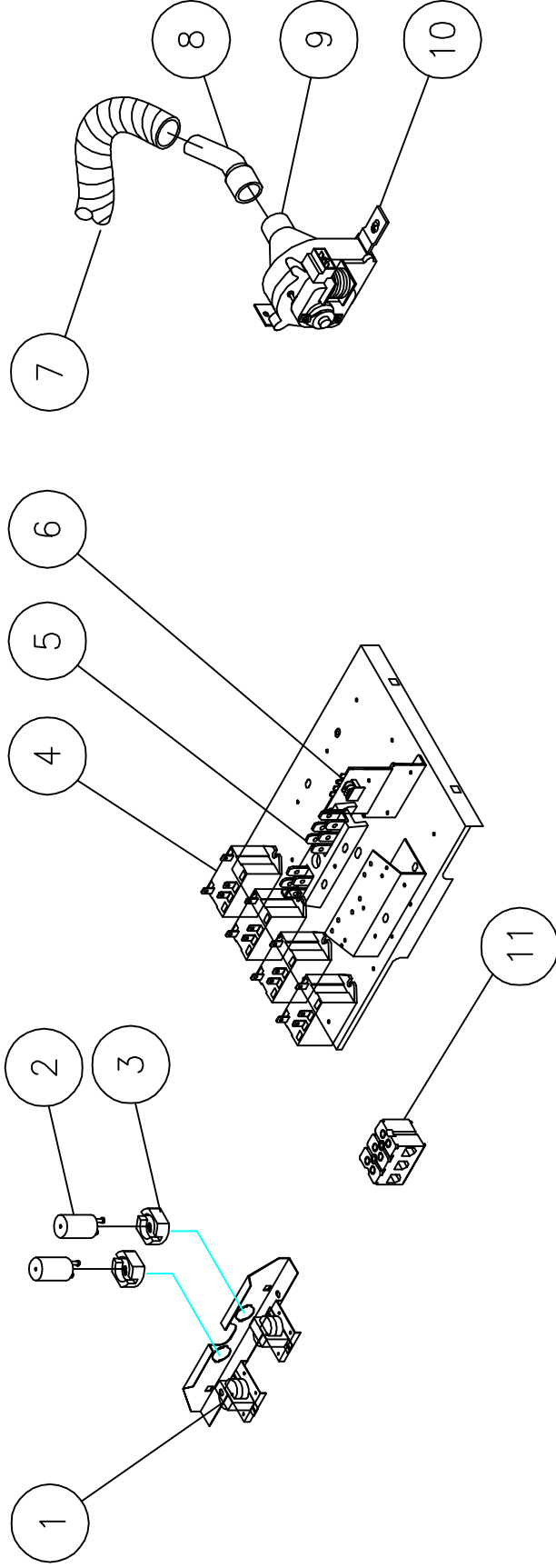

PARTS LIST

| ITEM | DESCRIPTION | P/N | QTY |
|------|------------------------------------|-------|-----|
| 1 | BALLAST | CE221 | 4 |
| 2 | STARTER TYPE FS-5 | L396A | 4 |
| 3 | STARTER BASE | B128A | 4 |
| 4 | RELAY 120V | B129A | 8 |
| 5 | TERMINAL BLOCK | 60112 | 2 |
| 6 | DUAL PROBE LIQUID LEVEL CONTROLLER | L690A | 2 |
| 7 | DUCT HOSE 1" x 16" | CD214 | 2 |
| 8 | ELBOW INSERT | CD108 | 2 |
| 9 | FAN CUP | CD57A | 2 |
| 10 | FAN | CD56A | 2 |
| 11 | TERMINAL BLOCK | B000A | 2 |

HOT WATER TANK RL72C (R)

USED ON: GB5-LD-U & GB8M-10-LD-U (RIGHT SIDE)

HOT WATER TANK SM90C (L)

USED ON: GB8M-10-LD-U (LEFT SIDE)

TANK DIMENSIONS:

12" WIDE, 4.8" DEEP, 16.5" HIGH.

APPROX. 3.7 GAL.

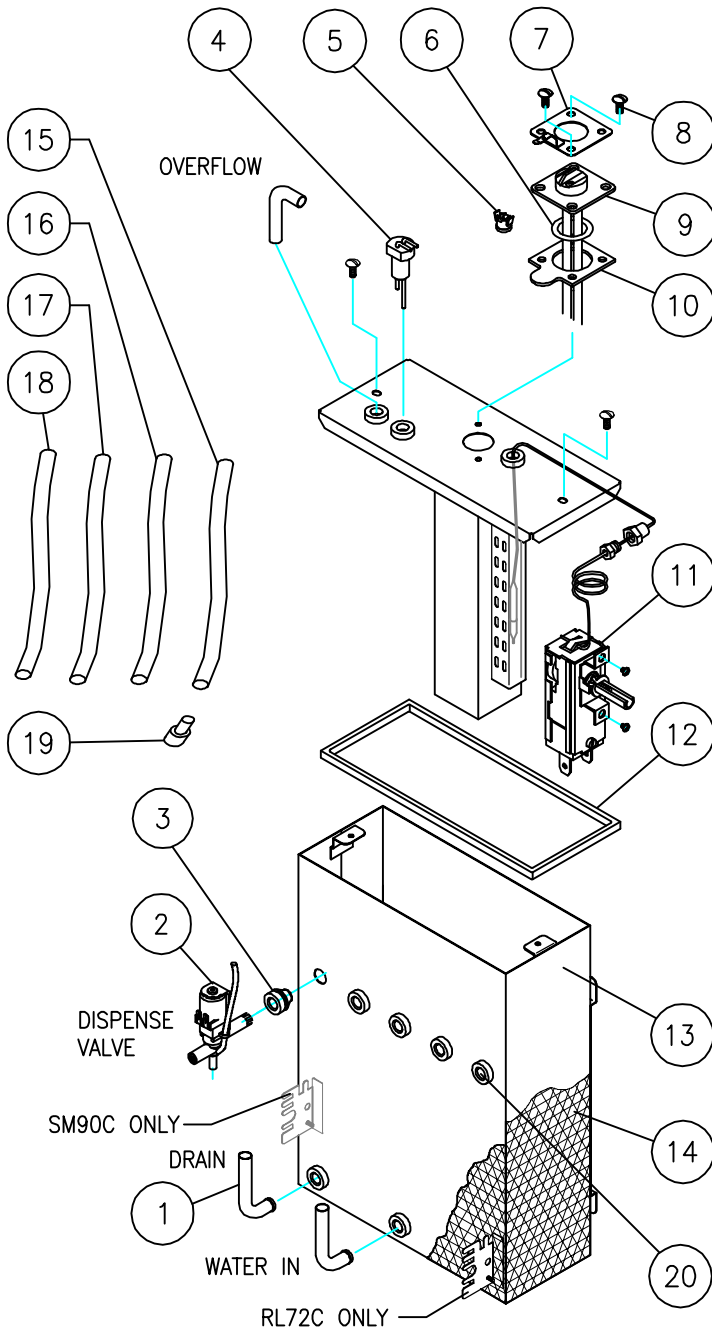

PARTS LIST

| ITEM | DESCRIPTION | P/N | QTY |
|------|--|-------|-----|
| 1 | ELBOW 90° | K525A | 3 |
| 2 | DISPENSE VALVE | L467A | 5 |
| 3 | SILICONE SEAL (0.466 ID) | M461A | 10 |
| 4 | DUAL PROBE | K695Q | 1 |
| 5 | HI-LIMIT 200° CUTOUT, 5/8" TRIG, #T500 | L656A | 1 |
| 6 | O-RING 1 1/4 ID x 1 5/8 OD | M773A | 1 |
| 7 | HEATSINK SHIM ASSEMBLY | K667Q | 1 |
| 8 | SCREW, 1/4-20x5/8, SST, TRUSS HD, SLTD | P465A | 4 |
| 9 | HEATER, 120V 1700W | G267A | 1 |
| 10 | HEATSINK, 1/8" ALUMINUM #1100 | K661A | 1 |
| 11 | THERMOSTAT | L681A | 1 |
| 12 | SILICONE BUTT SPLICED GASKET | M500A | 1 |
| 13 | TANK, 3.7 GAL RIGHT SIDE | RL72Q | 1 |
| 13 | TANK, 3.7 GAL LEFT SIDE | SM90Q | 1 |
| 14 | TANK INSULATION | M671A | 1 |
| 15 | TUBE, DRAIN | M622A | 1 |
| 16 | TUBE, OVERFLOW | M622A | 1 |
| 17 | TUBE, DISPENSE | M619A | 5 |
| 18 | TUBE, WATER INLET | M483A | 1 |
| 19 | DRAIN PLUG | M391A | 1 |
| 20 | SILICONE PLUG | M494A | 1 |

HOT WATER TANK SJ61C

USED ON:

GB6M-10-LD-U

TANK DIMENSIONS:
 15" WIDE, 6" DEEP, 18" HIGH.
 APPROX. 6 GAL.

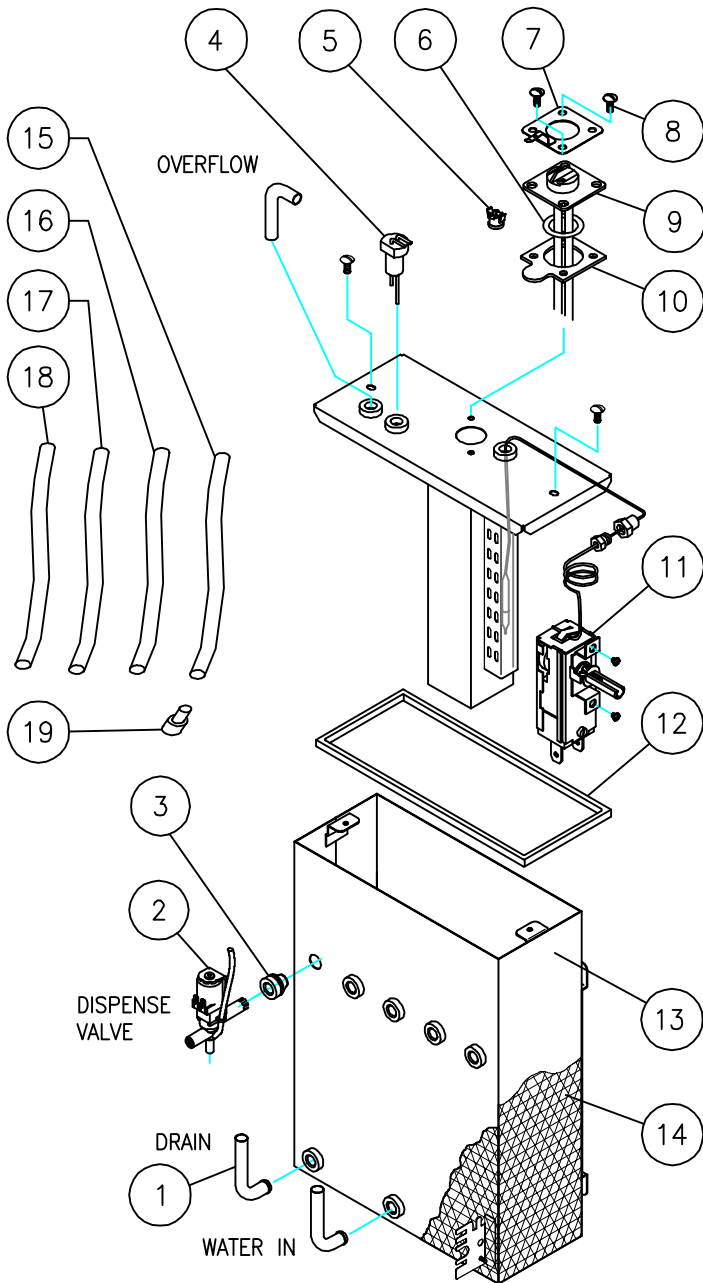

PARTS LIST

| ITEM | DESCRIPTION | P/N | QTY |
|------|--|-------|-----|
| 1 | ELBOW 90° | K525A | 2 |
| 2 | DISPENSE VALVE | L467A | 6 |
| 3 | SILICONE SEAL (0.466 ID) | M461A | 10 |
| 4 | DUAL PROBE | K695Q | 1 |
| 5 | HI-LIMIT 200° CUTOUT, 5/8" TRIG, #T500 | L656A | 1 |
| 6 | O-RING 1 1/4 ID x 1 5/8 OD | M773A | 1 |
| 7 | HEATSINK SHIM ASSEMBLY | K667Q | 1 |
| 8 | SCREW, 1/4-20x5/8, SST, TRUSS HD, SLTD | P465A | 4 |
| 9 | HEATER, 120V 1700W | G267A | 1 |
| 10 | HEATSINK, 1/8" ALUMINUM #1100 | K661A | 1 |
| 11 | THERMOSTAT | L681A | 1 |
| 12 | SILICONE BUTT SPLICED GASKET | M879A | 1 |
| 13 | TANK WELDMENT, 3.7 GAL | SJ61Q | 1 |
| 14 | TANK INSULATION | M881A | 1 |
| 15 | TUBE, DRAIN | M622A | 1 |
| 16 | TUBE, OVERFLOW | M622A | 1 |
| 17 | TUBE, DISPENSE | M619A | 5 |
| 18 | TUBE, WATER INLET | M483A | 1 |
| 19 | DRAIN PLUG | M391A | 1 |

NE220

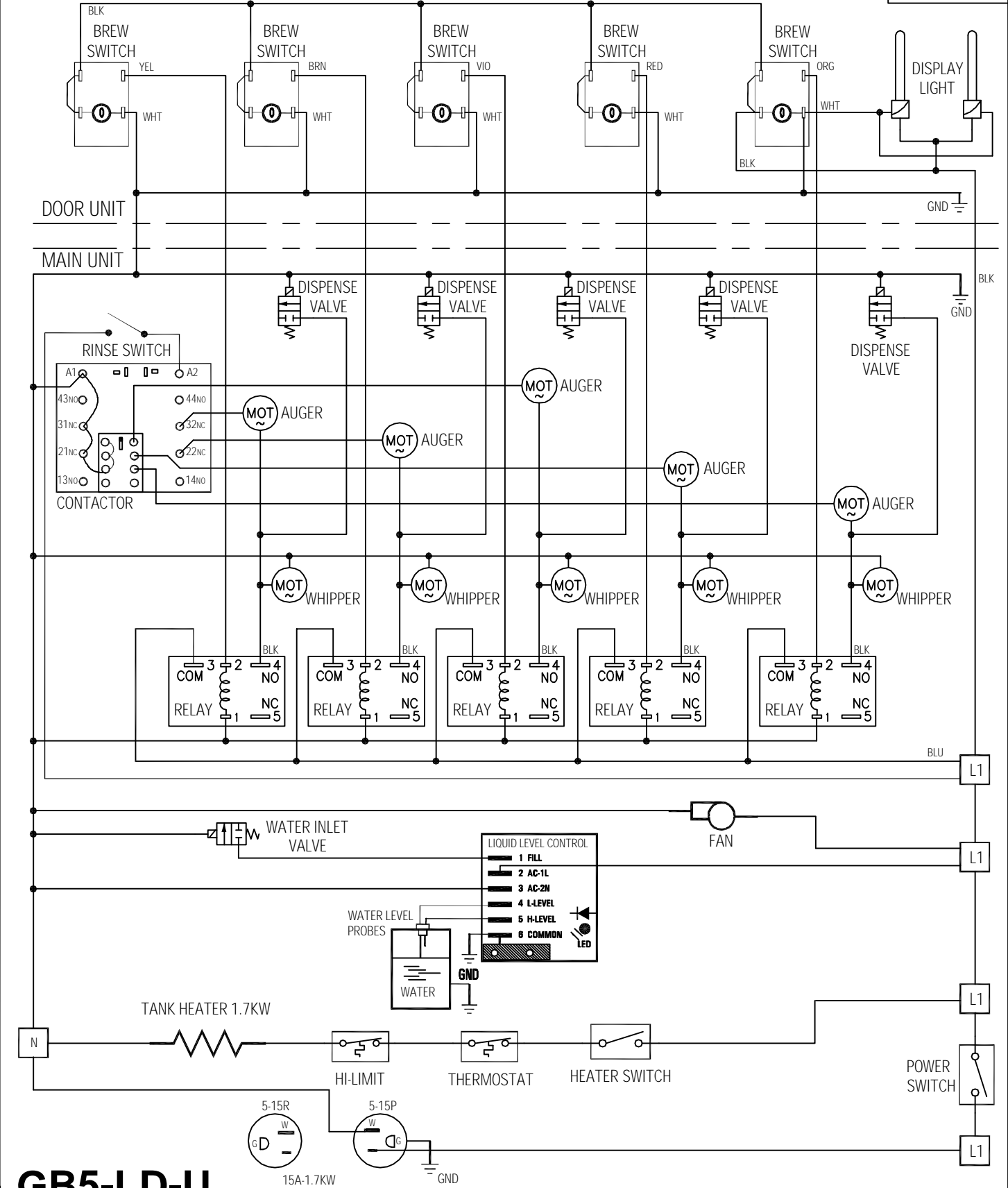

GB5-LD-U

| | | | | | | |
|--|----|------|-------------|-------------|-----------------|---------------|
| REV | BY | DATE | DESCRIPTION | APP'D BY | DATE | PART NO NE220 |
| | | | | DRAWN BY JR | DATE 11/07/2003 | SCALE NONE |
| CECILWARE CORPORATION 43-05 20 AVE. L.I.C. NY 11105 | | | | | | NE220 |
| TITLE: ELECTRICAL DIAGRAM (1.7KW, 120V, 2 WIRES, + GND), W/ RELAYS CONTACTOR | | | | | | REV. |

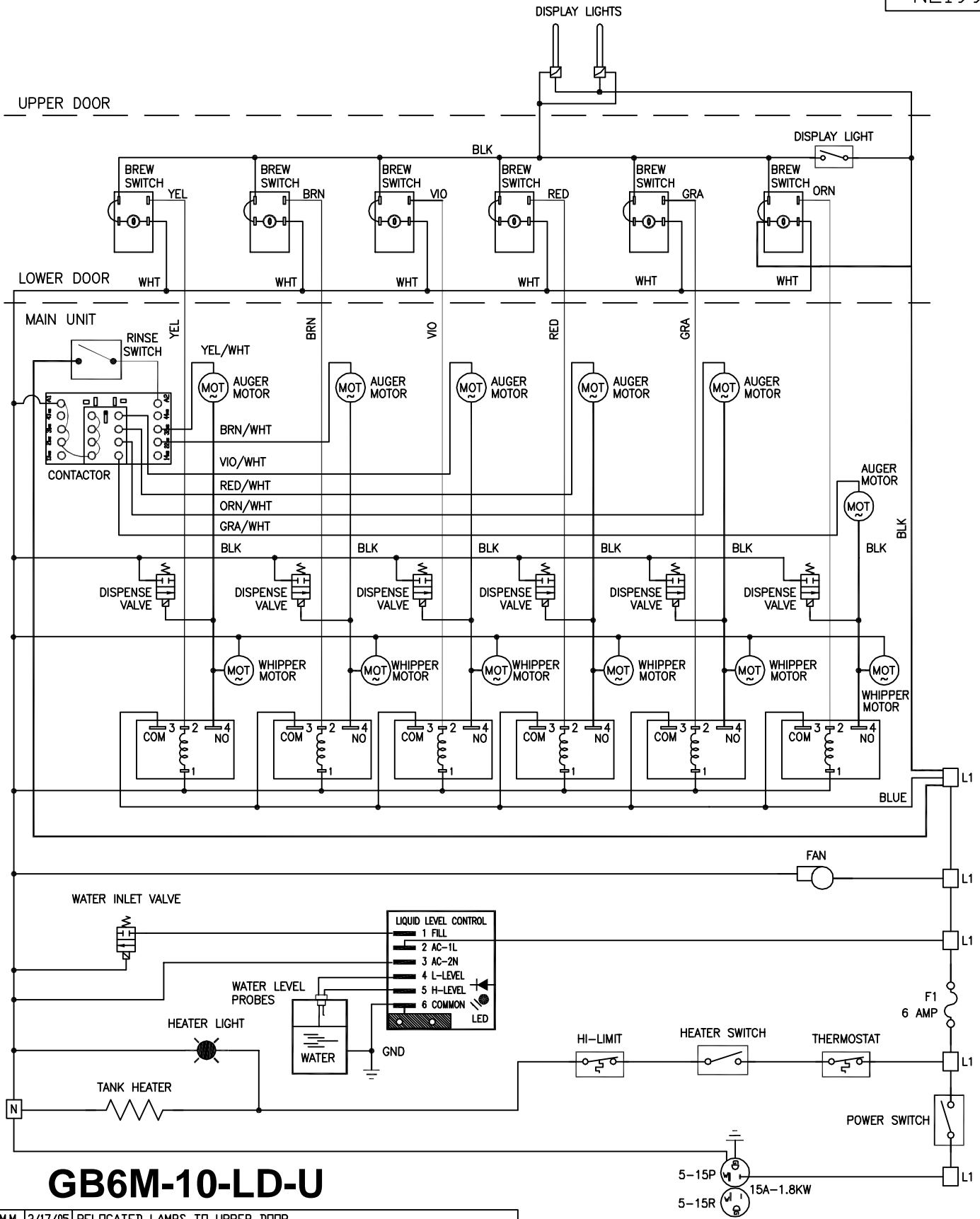

GB6M-10-LD-U

| | | | |
|-----|------|----------|--------------------------------|
| C | M.M. | 3/17/05 | RELOCATED LAMPS TO UPPER DOOR |
| B | | 03/14/05 | CHANGED LIGHTS AND SWITCH |
| A | CG | 3/22/03 | ADDED SAFETY SWITCH TO DIAGRAM |
| REV | BY | DATE | DESCRIPTION |

| | | |
|---------------|-----------------|----------------|
| APPROVED BY | DATE | PART NO. NE199 |
| DRAWN BY M.M. | DATE 11/15/2002 | SCALE N T S |

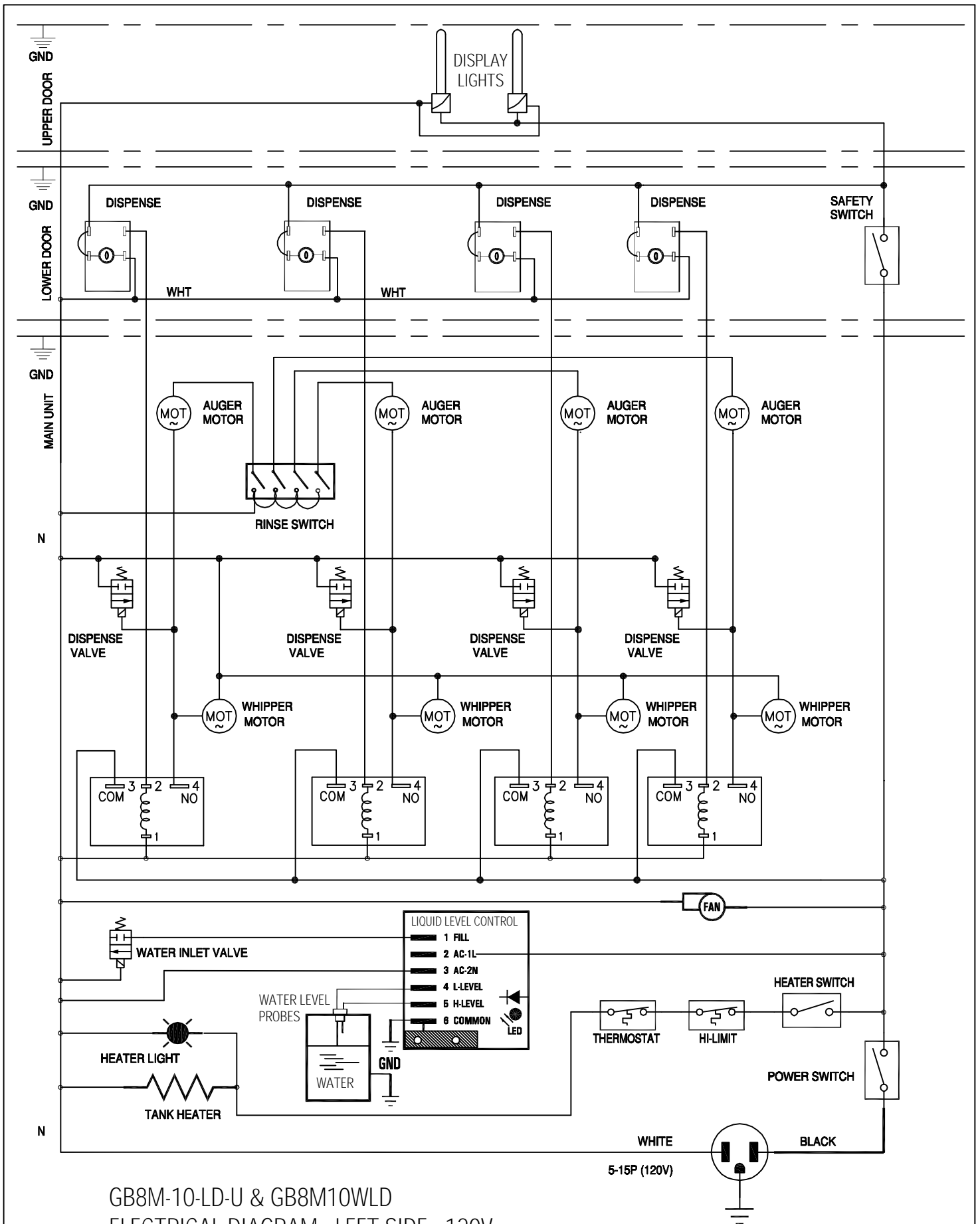

GB8M-10-LD-U & GB8M10WLD
ELECTRICAL DIAGRAM - LEFT SIDE - 120V

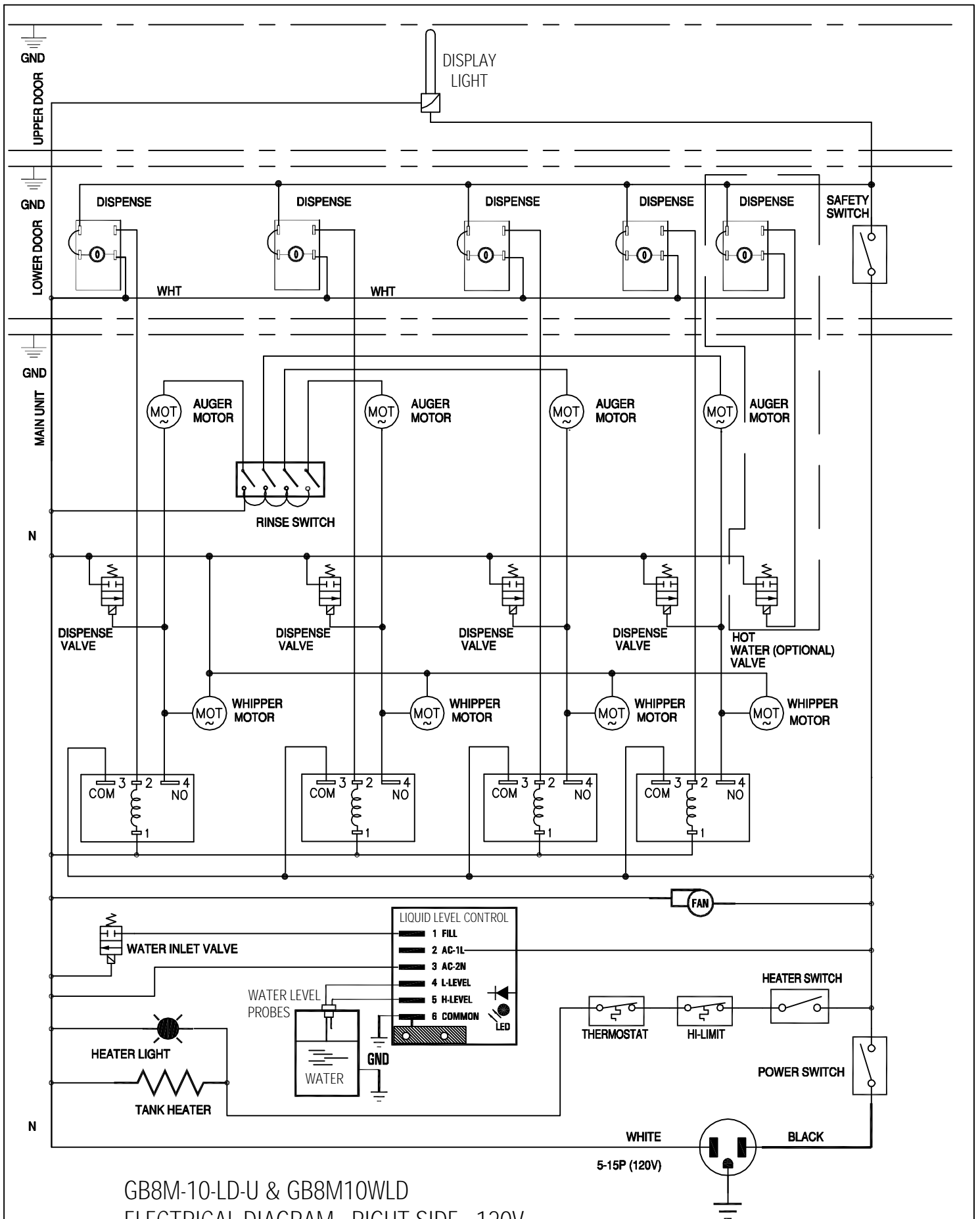

GB8M-10-LD-U & GB8M10WLD
ELECTRICAL DIAGRAM - RIGHT SIDE - 120V