

GOURMET MULTI-FLAVOR DISPENSERS



GB5MF-IT *(Intelligent Technology)*

- Microprocessor Technology
- Touch Pad Control Panel
- Free Flow and Portion Control
- Counts Total Volume of Drinks Dispensed
- Diagnostics for Electrical Problems
- Removable & Replaceable Picture

OPERATION MANUAL

- Specifications
- Installation and Operating Instructions
- Adjustments
- Programming Instructions
- Care and Maintenance
- Troubleshooting Guide
- Parts Specifications
- Wiring diagrams



Cecilware Corporation
43-05 20th. Avenue, LIC NY 11105
Tel: 800.935.2211 / 718.932.1414
Fax: 718.932.7860 • www.cecilware.com
Email: customer.service@cecilware.com

Cecilware sells value... Worldwide

Operation Manual
NM91A MAR. 2010

Model: GB5MF-IT

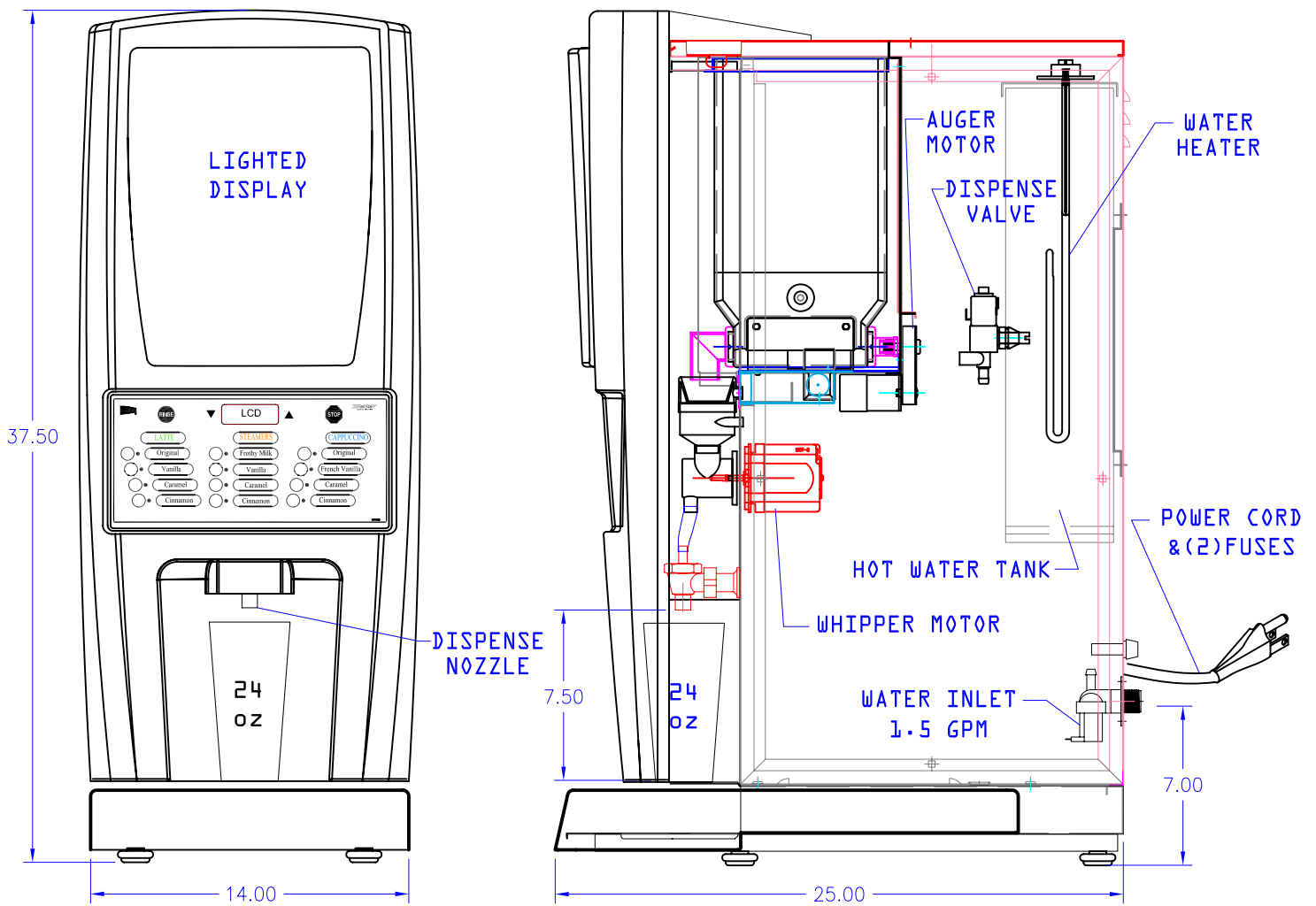

MECHANICAL SPECIFICATIONS

MODEL	WIDTH in	DEPTH in	HEIGHT in	HOPPERS lbs	TANK gal	LIT DISPLAY AREA in	SHIPPING WEIGHT lbs
GB5MF-IT	14.00	25.00	37.50	1 (10 lb) - 4 (2 lb)	3.7	10.75 x 14.00	120

ELECTRICAL SPECIFICATIONS

MODEL	VOLTS	PHASE	HZ	WATTS	HEATERS	AMPS	RECEPTACLE Nema No.	CIRCUIT BREAKER
GB5MF-IT	120	1	60	1800	1	15	5-15R	15A
GB5MF-IT	240	1	60	3000	1	15	6-15R	15A

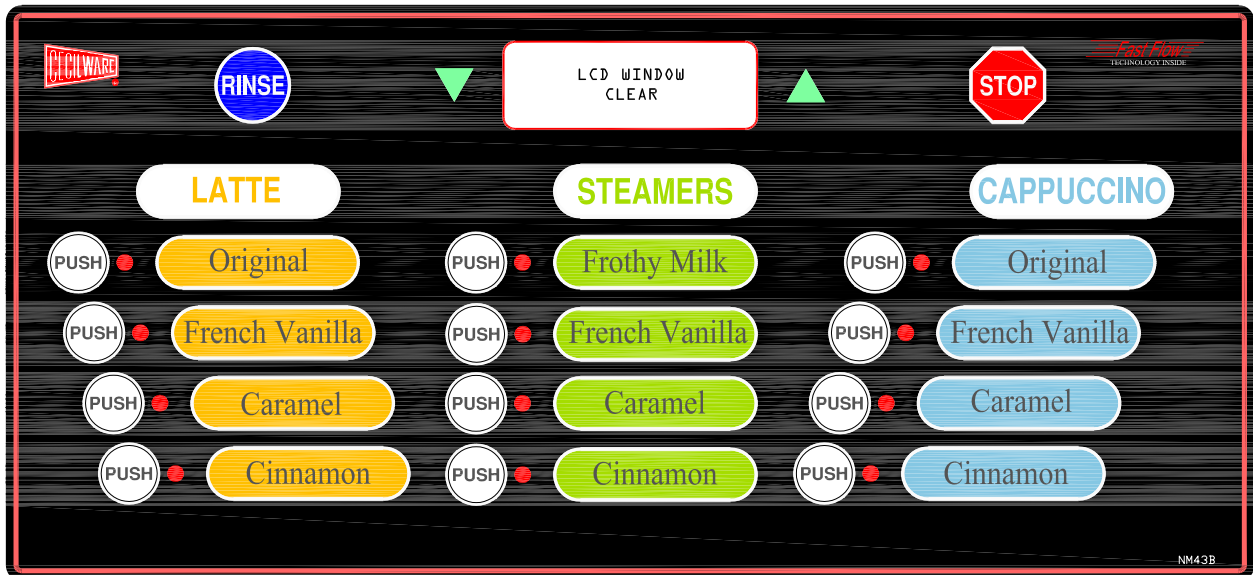

GB5-MF-IT FACTORY GRAM THROW SETTINGS

		FOR 8 OZ. CUP			9/16/2005	
		<u>FLAVOR</u>		<u>COFFEE</u>	<u>MILK</u>	
		VANILLA	CARAMEL	CINNAMON		
		5 grams	4 grams	5 grams	1.4 grams	20 grams
LATTES:						
ORIGINAL	0	0	0	70	60	
Fr. VANILLA	135	0	0	70	60	
CARAMEL	0	135	0	70	65	
CINNAMON	0	0	120	70	60	
STEAMERS:						
		VANILLA	CARAMEL	CINNAMON	COFFEE	MILK
		5 grams	4 grams	5 grams	0 grams	20 grams
FROTHY MILK	0	0	0	0	55	
Fr. VANILLA	110	0	0	0	55	
CARAMEL	0	135	0	0	55	
CINNAMIN	0	0	110	0	55	
CAPPUCCINO'S:						
		VANILLA	CARAMEL	CINNAMON	COFFEE	MILK
		5 grams	4grams	5 grams	2.2 grams	20 grams
ORIGINAL	0	0	0	140	60	
Fr.VANILLA	135	0	0	140	60	
CARAMEL	0	135	0	140	65	
CINNAMON	0	0	120	140	65	
ADJUSTMENT RANGE :						
VANILLA	Use 23.0 pts. Of drink strength to increase 1 gram of product					
CARAMEL	Use 23.0 pts. Of drink strength to increase 1 gram of product					
CINNAMON	Use 18.25 pts. Of drink strength to increase 1 gram of product					
COFFEE	Use 58.0 pts. Of drink strength to increase 1 gram of product					
MILK	Use 2.15 pts. Of drink strength to increase 1 gram of product					
					NN90A-A	

GB5MF-IT

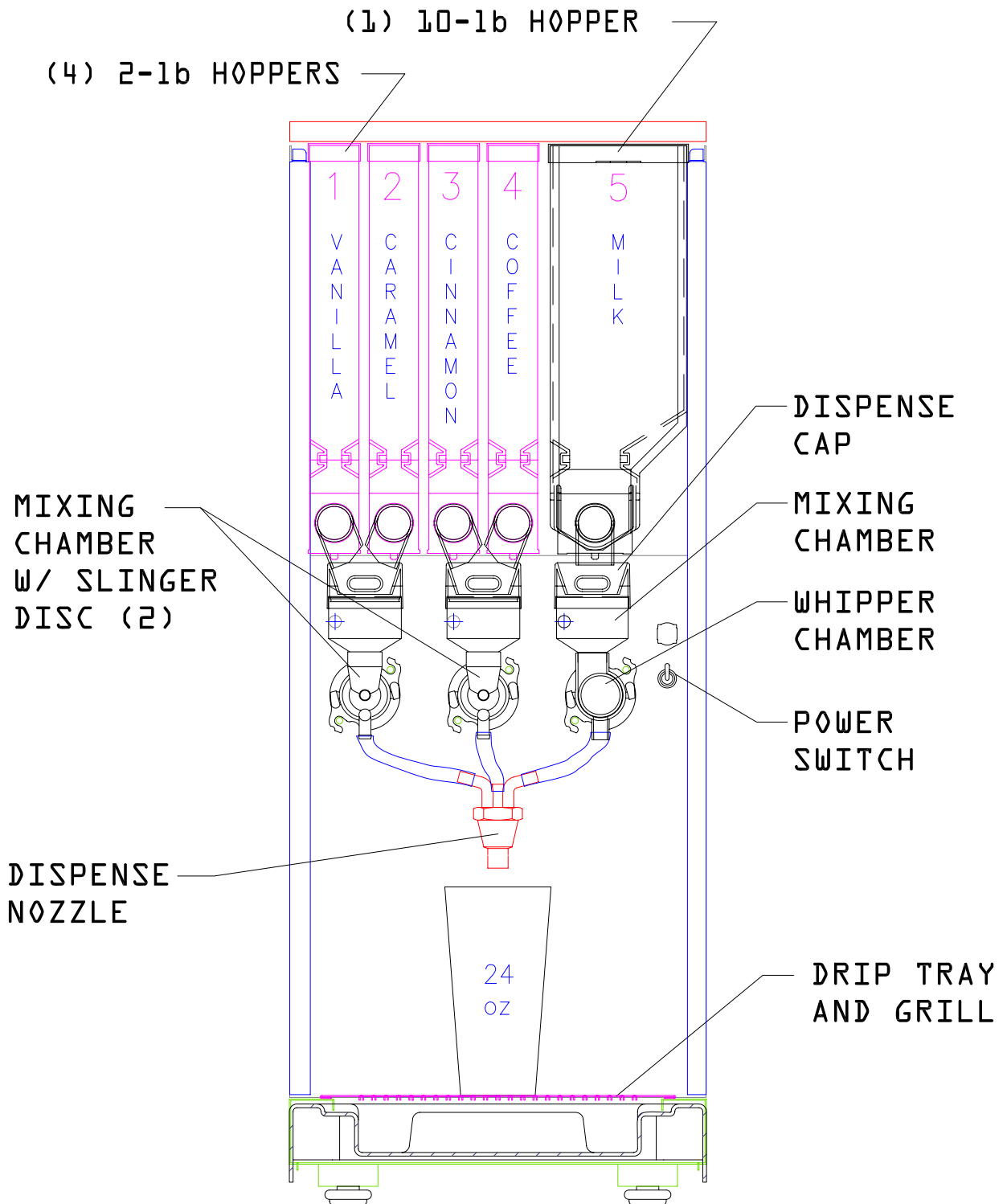

GB5-MF-HC-IT

Cafe Station

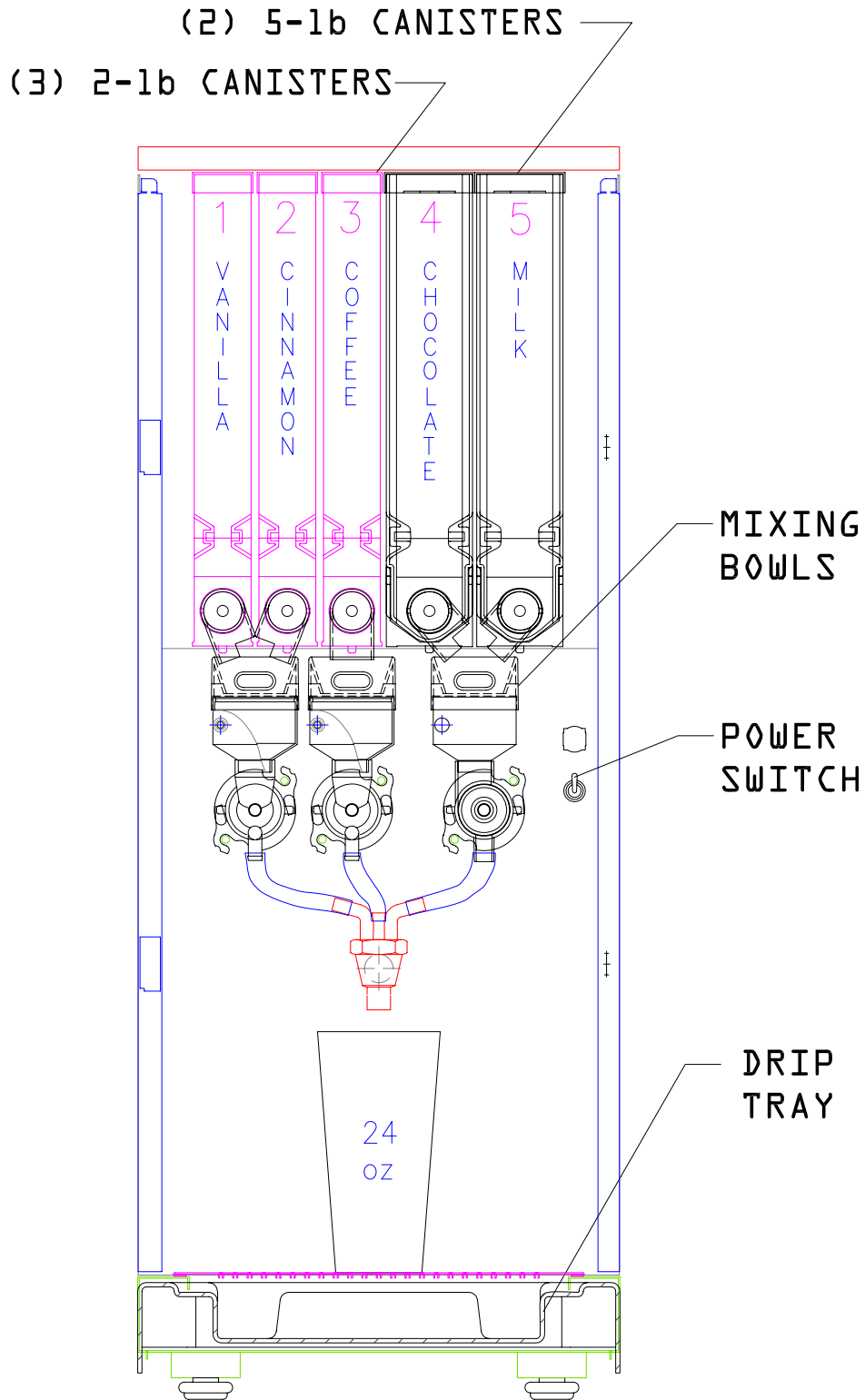

UNPACKING INSTRUCTIONS

Carefully unpack the GB Machine and inspect immediately for shipping damage. Your GB Machine was shipped in a carton designed to give it maximum protection in normal handling. It was thoroughly inspected before leaving the factory. In case of damage, contact the shipper, not Cecilware.

INSTALLATION INSTRUCTIONS

Water Inlet Connection:

This equipment is to be installed to comply with the applicable Federal, State, or local plumbing codes having jurisdiction. In addition:

1. A quick disconnect water connection or enough extra coiled tubing (at least 2x the depth of the unit) so that the machine can be moved for cleaning underneath.
2. An approved back flow prevention device, such as a double check valve to be installed between the machine and the water supply.

The GB beverage dispenser is equipped with a 3/4" Garden Hose Connector which is located on the back of the unit.

HIGHLY RECOMMENDED:

A WATER SHUT-OFF VALVE and A WATER FILTER, preferably a combination Charcoal/ Phosphate Filter, to remove odors and inhibit lime and scale build up in the machine.

Note: In areas with extremely hard water, a water softener must be installed in order to prevent a malfunctioning of the equipment and in order not to void the warranty.

After the machine has been unpacked and placed on a counter, pull out the drip tray. It should contain the following:
A Set of 4 Adjustable Leveling Legs and a 1/4" Flare Water Inlet Fitting.

START-UP PROCEDURE

1. Connect the 1/4" dia. copper waterline to the 1/4" flare water inlet fitting of the valve.
2. Plug the power cord into a proper receptacle.
3. Activate the Power Switch (Toggle Up) located on the right side of the splash panel behind the door.
The power switch controls all power to the machine including the heater elements.
The door display panel will light up and the tank will start filling.
The LCD window will display this message briefly "CECILWARE, DISPENSER V#.##".
4. The LCD window will display this message "Low Water Level". Allow approximately 3 to 5 minutes for the tank to fill.
If the tank does not fill up within the first 5 minutes an error message will appear in the LCD window [SYSTEM ERROR, FILL RESPONSE].
See Definition of Screen and Troubleshooting Guide.
5. The LCD window will display this message "Low Water Temp." Allow up to 30 minutes for the water to reach a temperature of 190°F.
The heat up time will depend on the water inlet temperature, the input voltage and the wattage of the elements in the machine.

While the tank is heating up, remove the hoppers, load them with products and reposition them back in the machine. Be sure to reposition the hoppers so that the 1/4" pin slides into the hole of the compartment base.

When the machine has reached the proper dispensing temperature, the LCD window will display, "Press & Release to Dispense" and "Please select choice of Drink".

WATER LEVEL CONTROLS:

Under normal conditions and operation, the water level in the tank should not drop more than ½" from the probe. If it does, the tank is not refilling fast enough. Check the water line and water filter, they may need cleaning or replacing.

Water Inlet Valve L462A

Water Level Probe K402Q [K402A & P410A]

ADJUSTMENTS

WATER FLOW RATE

The Dispense Valves are factory adjusted for a proper Flow Rates.

[Approximate settings: 0.75 oz./sec for MILK; 0.375 oz./sec. for COFFEE and FLAVORS]

Exceeding this Flow Rate will cause the Mixing Chamber to overflow.

Note: To access the Water Dispense Valves, open door and remove Hoppers.

TO ADJUST WATER FLOW RATE:

1. Open door and remove hoppers. Locate Dispense Valve behind hoppers, mounted on tank.
2. Locate adjustment screw on Dispense Valve.
3. Using a 3/16" Allen Key or flat screwdriver rotate, 1/4 turn at a time, CLOCKWISE to decrease water flow, or COUNTERCLOCKWISE to increase water flow.
4. Check water flow output, after each 1/4 turn.

WATER FLOW ADJUSTMENT

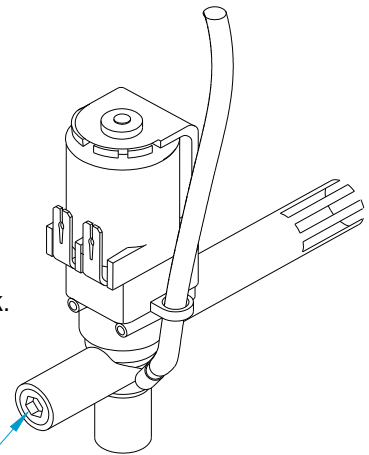

PROGRAMMING INSTRUCTIONS

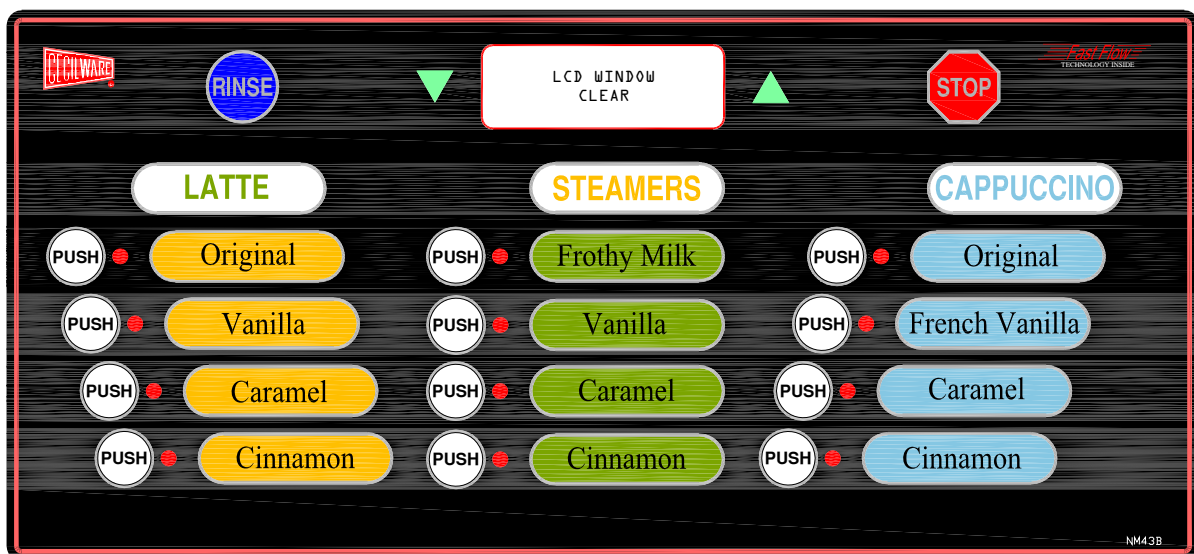
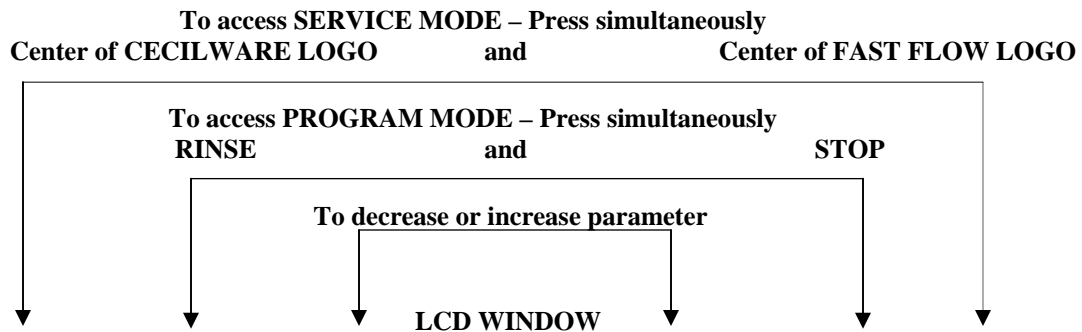

MODES OF OPERATION

1. **Initializing Mode** – This mode is only active during the first few seconds after a “power-on” or system reset. The main function of this mode is to configure the system using the previously saved operating parameters.
2. **Normal Mode** – This mode becomes active immediately after Initializing Mode has completed its tasks. The main functions of this mode are to monitor and report system status and control dispensing.
3. **Rinse Mode** – This mode becomes active when the *Rinse* key is depressed with any dispense key. The main function of this mode is to allow the operator to initiate an individual Rinse for all mixing chambers.
4. **Program Mode** – This mode becomes active when the *Rinse* and the *Stop* keys are simultaneously depressed for more than 1.5 seconds while in Normal Mode. The main function of this mode is to provide limited access to frequently used system parameters. Pressing the *Rinse* and the *Stop* keys again will return the touchpad to normal mode.
5. **Service Mode** – This mode becomes active when the hidden keys under the “Cecilware Logo” and the “Fast Flow Logo” are simultaneously depressed for more than 1.5 seconds while in Normal Mode. The main function of this mode is to allow access to all system parameters that can be modified. Pressing the “Cecilware Logo” and the “Fast Flow Logo” again will return the touchpad to normal mode.

Features and Benefits of the Digital Dispenser Controller

1. 100% Solid State Control for improved reliability
2. Modular design and reduced component count for ease of service
3. Optional sanitary features such as Rinse Lockouts and Rinse Warnings
4. Redundant system interlocks for uncompromising user safety
5. Large two line display for viewing system status and modifying parameters
6. Individual dispense counters and totalizers for product marketing information and inventory control
7. Advanced system diagnostics that continuously monitor the status of all motors, solenoids, sensors, and heaters to ensure proper operation and aid in identifying potential problems
8. Protection from heater burnout due to lack of water in the reservoir tank
9. Elimination of dry powder feed at the beginning of a dispense and product dilution at the end of a dispense
10. Extremely accurate dispensing control utilizing DC servo-motor drive technology
11. Stable water temperature regulation with an adjustment resolution of one-degree Fahrenheit
12. Optional Low Water Temperature Lockout to prevent dispensing at water temperatures below an adjustable threshold
13. Units of measure displayed in either English or Metric
14. Digital adjustment of serving sizes with a resolution of one-tenth of an ounce
15. Digital adjustment of gram throw with a resolution of one-percent-of-maximum
16. Audible alarm
17. User selectable "Portion Control" or "Free Flow" dispense modes
18. Optional power saving "sleep mode" for extended periods of inactivity
19. Easy to use menu-driven dispensing and rinsing instructions

PARAMETER DEFINITIONS FOR SYSTEM SOFTWARE

1. **Dispense Total** – This parameter indicates the total amount of water dispensed (in ounces or milliliters) for a mixing chamber. The Dispense Total does not include Rinse Dispenses. The maximum Dispense Total value is 16,777,216 ounces; after which the value will begin again from zero. This parameter cannot be reset to zero. Default Values has no effect on this parameter.
2. **Dispense Counter** – This parameter indicates the total number of cups dispensed for a selected Serving Size. The Dispense Counter does not include Rinse Dispenses. The maximum Dispense Counter value is 49,999; after which the value will begin again from zero. In Service Mode this parameter can be reset to zero by simultaneously depressing the ▼ and ▲ Keys. Default Values has no effect on this parameter.
3. **Dispense Mode** – This parameter determines whether the system dispenses in a continuous (Free Flow) or fixed size (Portion Control) method. The default setting for this parameter is Portion Control.
4. **Serving Size** – This parameter determines the amount of water dispensed for each Dispense Key when the Dispense Mode is set to Portion Control. The default setting is 8.0 ounces. The minimum Serving Size is 2.0 ounces. The maximum Serving Size is 64.0 ounces.
5. **Gram Throw** – This parameter determines the ratio of product to water during a Dispense for a selected Hopper. The units of measure for Gram Throw are proportional to Auger Turns per ounce of water. At a Fill Constant of 1.00 ounces per second the maximum Gram Throw is 100 and the minimum Gram Throw is 20. The maximum and minimum values are scaled proportional to a Fill Constant of 1.00 ounces per second. For example: if the Fill Constant is set to 1.30 ounces per second the maximum Gram Throw would be $(100 \times 1.00) / 1.3 = 77$. This prevents the user from requesting a Gram Throw that is beyond the capability of the Auger Motor. Auger Start and Stop Times have no effect on this parameter. The default setting for this parameter will reset all gram throw settings to factory specs.
6. **Auger Start Time** – This parameter sets the time that the Auger starts to turn relative to the activation (opening) of the Dump Valve. A positive value indicates an Auger starting at some time after the opening of the Dump Valve. A negative number indicates an Auger starting at some time before the opening of the Dump Valve. The minimum Auger Start Time = (-3.0) seconds. The maximum Auger Start Time is 3.0 seconds. The default value for this parameter is 0.3 seconds.
7. **Mixer Start Time** – This parameter sets the time that the Mixer starts to turn relative to the activation (opening) of the Dump Valve. A positive value indicates a Mixer starting at some time after the opening of the Dump Valve. A negative number indicates a Mixer starting at some time before the opening of the Dump Valve. The minimum Mixer Start Time = (-3.0) seconds. The maximum Mixer Start Time is 3.0 seconds. The default value for this parameter is 0.3 seconds.
8. **Auger Stop Time** – This parameter sets the time that the Auger stops turning relative to the de-activation (closing) of the Dump Valve. A positive value indicates an Auger stopping at some time after the closing of the Dump Valve. A negative number indicates an Auger stopping at some time before the closing of the Dump Valve. The minimum Auger Stop Time = (-3.0) seconds. The maximum Auger Stop Time is 3.0 seconds. The default value for this parameter is 0.3 seconds.
9. **Mixer Stop Time** – This parameter sets the time that the Mixer stops turning relative to the de-activation (closing) of the Dump Valve. A positive value indicates a Mixer stopping at some time after the closing of the Dump Valve. A negative number indicates a Mixer stopping at some time before the closing of the Dump Valve. The minimum Mixer Stop Time = (-3.0) seconds. The maximum Mixer Stop Time is 3.0 seconds. The default value for this parameter is 0.6 seconds.
10. **Fill Constant** – This parameter must be set for each of the Dump Valves. The maximum Fill Constant is 1.5 oz/sec. The minimum Fill Constant is 0.1 oz/sec. The maximum and minimum values are scaled proportional to a Gram Throw of 100. For example: if the highest Gram Throw setting is 77 then the maximum Fill Constant would be $(100 \times 1.00) / 77 = 1.30$. This prevents the user from requesting a Gram Throw that is beyond the capability of the Auger Motor. The default settings for this parameter are 0.25 ounces per second for LEFT & MIDDLE CHAMBER, and 1.00 oz/sec For RIGHT (Milk) CHAMBER.
11. **Rinse Dispense Time** – This parameter determines the amount of time that the Dump Valve is open during a Rinse Cycle. The minimum Rinse Time = 3 seconds. The maximum Rinse Time is 15 seconds. The default value for this parameter is 6 seconds.

12. **Rinse Warning Status** – This parameter determines whether the Rinse Warning Option is turned ON or OFF. If this option is ON the system generates a Rinse Warning if a Hopper has dispensed and has not been rinsed for a period of time greater than that defined by the Rinse Warning Time. Generating a Rinse Warning will cause the audible alarm to sound for two seconds and the Rinse Warning Screen to be displayed for five seconds. The system will then revert back to normal operation. If the offending Hopper is not rinsed after the first Rinse warning additional Rinse Warnings will be generated every five minutes until the respective Hopper is rinsed. **The default setting for this parameter is OFF.**
13. **Rinse Lockout Status** - This parameter determines whether the Rinse Lockout Option is turned ON or OFF. If this option is ON the system generates a Rinse Lockout if a Hopper has dispensed and has not been Rinsed for a period of time greater than that defined by the Rinse Lockout Time. Once a Hopper enters Rinse Lockout the LED's of the Dispense Keys related to that Hopper will turn OFF thus indicating that the Hopper will no longer dispense. **The default setting for this parameter is OFF.**
14. **Rinse Lockout Time** – This parameter determines the length of time required before entering Rinse Lockout. The minimum Rinse Lockout Time = 1 hour. The maximum Rinse Lockout Time is 12 hours. **The default value for this parameter is 4 hours.**
15. **Water Temperature Set Point** – This parameter determines the required reservoir tank water temperature. The minimum Water Temperature Set Point is 140°F. The maximum Water Temperature Set point is 203°F. **The default value for this parameter is 190°F.**
16. **Low Water Temperature Lockout Status** – This parameter determines whether the Low Water Temperature Lockout Option is turned ON or OFF. If this option is ON the system generates a Low Water Temperature Lockout if the present water temperature is below the value defined by the Low Water Temperature Lockout Set Point. Once a Hopper enters Low Water Temperature Lockout, all of the Dispense Key LED's will turn OFF thus indicating that the system will no longer dispense. **The default setting for this parameter is OFF.**
17. **Low Water Temperature Lockout Set Point** – This parameter determines the minimum reservoir tank water temperature allowed before entering Low Water Temperature Lockout. The minimum Low Water Temperature Lockout Set Point is 125°F. The maximum Low Water Temperature Lockout Set point is 203°F. **The default value for this parameter is 140°F.**
18. **Water Level Actual** – This parameter provides a readout of the water hardness level in the tank. Once provided, the water level Setpoint can be adjusted so that the system will recognize the absence or presence of water at the level probes, thus controlling the water level.
19. **Water Level Setpoint** – This parameter indicates the numerical value that the “Water Level Actual” readout must be before the system allows water to fill the tank and eventually make contact with the level probes. Note: the “Water Level Setpoint must be a higher reading than the “Water Level Actual”. **The default value for this parameter is 400.**
 - * If the “Water Level Actual” is higher than 400 then the Setpoint must be adjusted to a value 50 – 100 above the “Water Level Actual” reading. This would be in a Hard Water condition.
 - * If the “Water Level Actual is 300 or more below the default reading of 400, then the Setpoint must be adjusted to 50 – 100 above the “Water Level Actual” reading. This would be in a High Mineral content condition.
20. **Sleep Mode Status** – This parameter determines whether the Sleep Mode Option is turned ON or OFF. If this option is ON and the system has not dispensed for four hours the system will enter Sleep Mode. Once in Sleep Mode the system will reduce the required Water Temperature to equal that defined by (10°F + Low Water Temperature Lockout Set Point). **The default setting for this parameter is OFF.**
21. **Hopper Status** – This parameter determines the whether a selected Hopper is turned ON or OFF. If a Hopper is ON then the Auger Motor, Mixer Motor, and Dump Solenoid status checking is enabled and the Hopper is allowed to dispense. If a Hopper is OFF then Auger Motor, Mixer Motor, and Dump Solenoid status checking is disabled and the LED's of the Dispense Keys related to that Hopper will turn OFF thus indicating that the Hopper will no longer dispense. **The default setting for this parameter is ON.**

22. **Blower Diagnostics** – This parameter will monitor the status of the blower motor and display a warning if it senses a problem. **The default setting for this parameter is OFF.**
23. **Displayed Units** – This parameter determines whether the displayed units of measure are English or Metric. If the Displayed Units parameter is set to English then all temperatures are displayed as Degrees Fahrenheit and all volumes are displayed as Fluid Ounces. If the Displayed Units parameter is set to Metric then all temperatures are displayed as Degrees Celsius and all volumes are displayed as Milliliters. **The default setting for this parameter is English.**
24. **Clock Settings** – Need to set clock date (DAY, MONTH and YEAR) at the beginning life of the machine.
25. **Default Values** – Resets all parameters to FACTORY SETTINGS.

INITIALIZING MODE

Each time the Dispenser is switched ON, the following screen will appear:
It should be noted that this is the only time the System Software Version Number (V #.##) is displayed.
All other functions of this mode are completely transparent to the operator.

CECILWARE
DISPENSER V#.##

NORMAL MODE

The following is a list of functions performed by this mode:

- 1. Dispensing Control** - This mode is responsible for implementing and supervising the dispensing process.
- 2. Water Level Control** - This mode is responsible for maintaining the proper level of water in the reservoir tank.
- 3. Water Temperature Control** - This mode is responsible for maintaining the required water temperature in the reservoir tank.
- 4. Sanitary (Rinse) Functions** - This mode is responsible for annunciating and enforcing rinse warnings and lockouts.
- 5. Safety Functions** - This mode is responsible for monitoring all sensors, motors, solenoids, and heaters for proper operation.

RINSE MODE

A complete rinse is initiated by simultaneously pressing the *Rinse* key and any *Dispense* key.

PROGRAM MODE

General Conventions (unless otherwise indicated)

- To enter or exit Program Mode, simultaneously press both the *Rinse* Button and the *Stop* Button until the buzzer sounds.
(Approximately 1.5 seconds).
- Pressing the *Stop* Key will cause the menu to scroll up and pressing the *Rinse* Key will cause the menu to scroll down.
- The blinking LED's signify which Hopper or Serving Size the displayed parameter corresponds to.
- Pressing the ▼ or ▲ Key individually will decrease or increase the displayed parameter respectively.
- Pressing the ▼ and ▲ simultaneously will cause the parameter to revert to a default value.

Functions:

-
- Displays total volume dispensed

DISPENSE TOTAL
#####.# OZ.

-
- Displays total volume dispensed since last reset.

DISPENSE COUNTER
#####.# OZ.

-
- Shows hopper status, ON/OFF, for each of the 5 hoppers. 5 LEDs will light to indicate hopper number.

AUGER ON/ OFF
SELECT A KEY

-
- Select status for the hopper by pressing each of the lighted hoppers and then pressing ▼ or ▲ .

AUGER ON/ OFF
#_IS ON

AUGER ON/ OFF
#_IS OFF

SERVICE MODE

General Conventions:

1. To **enter** or **exit** Service Mode simultaneously depress both the hidden key behind the **Cecilware Logo** and the hidden key behind the **Fast Flow Logo** until the buzzer sounds (approximately 1.5 seconds).
2. Pressing the *Stop* key will cause the menu to scroll up and pressing the *Rinse* key will cause the menu to scroll down.
3. The blinking LED(s) signify which Hopper or Serving Size the displayed parameter corresponds to.
4. Pressing the ▼ and ▲ keys individually will decrease or increase the displayed parameter respectively.
5. Pressing the ▼ and ▲ keys simultaneously will cause the parameter to revert to a default value.

Functions:

1. **DISPENSE TOTAL:** Displays total volume dispensed.

DISPENSE TOTAL
#####.# OZ.

2. **DISPENSE COUNTER:** Displays total volume dispensed since last reset.
Reset counter by simultaneously pressing the ▼ and ▲ keys.

DISPENSE COUNTER
#####.# OZ.

3. **PRODUCT DISPENSE:** If the ▼ and ▲ keys are pressed the Dispense Mode will toggle between “free flow” and “portion control”.

PRODUCT DISPENSE
FREE FLOW

PRODUCT DISPENSE
PORTION CONTROL

4. **SERVING SIZE IN OUNCES:** Pressing ▼ or ▲ key will decrease or increase the **SERVING SIZE** respectively

SERVING SIZE
#####.# OZ

5. **GRAM THROW:** Pressing any of the *Dispense* keys will cause that LED to blink and the LCD screen will display the **Gram Throw** for the indicated Hopper.
Please Note: each key needs to be pressed up to 5X to set each of the 5 hoppers.

GRAM THROW
SELECT A KEY

6. Pressing ▼ or ▲ key will decrease or increase the **Gram Throw** respectively.

GRAM THROW
HOPPER ###

7. **AUGER START DELAY:** LCD screen will display the **Auger Start Time** for all the hoppers.

AUGER START TIME
#.# SEC

8. **MIXER START DELAY:** LCD screen will display the **Mixer Start Time** for all the mix chambers.

MIXER START TIME
#.# SEC

9. **AUGER STOP DELAY:** LCD screen will display the **Auger Stop Time** for all the hoppers.

AUGER STOP TIME
#.# SEC

10. **MIXER STOP DELAY:** LCD screen will display the **Mixer Stop Time** for the mix chambers.

MIXER STOP TIME
#.# SEC

11. **FILL CONSTANT:** 3 dispense LED's of the corresponding mix chambers will light. Pressing each one will display the water flow “Fill Constant” for the corresponding mixing chamber.
Pressing the ▼ or ▲ keys will decrease or increase the flow rate respectively.

FILL CONSTANT
SELECT A KEY

FILL CONSTANT
#-- OZ/SEC.

12. *RINSE TIME*: is displayed in Seconds as shown.
Pressing the ▼ or ▲ keys will decrease or increase the rinse time respectively.
Default time is 6 Seconds

RINSE TIME
SEC.

13. *RINSE WARNING STATUS*: If the ▼ and ▲ keys are pressed the Rinse Warning Screen will toggle between “ON” and “OFF”.

RINSE WARNING
ON/OFF

14. *RINSE WARNING*: Pressing the ▼ and ▲ keys will decrease or increase the time between rinse warnings respectively

RINSE WARNING
HRS

15. *RINSE LOCKOUT STATUS*: If the ▼ and ▲ keys are pressed the Rinse Lockout will toggle between “ON” and “OFF”.

RINSE LOCKOUT
ON/OFF

16. *RINSE LOCKOUT TIME*: Pressing the ▼ or ▲ keys will decrease or increase the Rinse Lockout time respectively.

RINSE LOCKOUT
HRS

17. *WATER TEMPERATURE ACTUAL*: Displays current water tank temperature.

WATER TEMP ACTUAL
DEG F

18. *WATER TEMPERATURE SETPOINT*: Pressing the ▼ or ▲ keys will decrease or increase the water temperature.

WATER TEMP SET POINT
DEG F

19. *LOW TEMPERATURE LOCKOUT STATUS*: If the ▼ and ▲ keys are pressed Low Temperature Lockout will toggle between “ON” and “OFF”.

TEMP. LOCKOUT
ON/OFF

20. *LOW TEMPERATURE LOCKOUT TEMPERATURE*: Pressing the ▼ and ▲ keys will decrease or increase Lockout temperature.

LOW TEMP LOCKOUT
SETPOINT
DEG F

21. *WATER LEVEL ACTUAL*: Displays a value that indicates the presence or absence of water at the level probe.

WATER LEVEL ACTUAL
###

22. *WATER LEVEL SETPOINT*: Displays the value that will signal to the board the presence or absence of water at the level probe. Water level setpoint value must be higher than water level actual.

WATER LEVEL SETPOINT
###

23. *SLEEP MODE*: If the ▼ and ▲ keys are pressed, Sleep Mode will toggle between “ON” and “OFF”

SLEEP MODE
ON/OFF

24. *AUGER STATUS*: Pressing any of the *Dispense* keys will cause the *Dispense* LED's of the corresponding Hopper to blink and the LCD screen will display the status for the indicated Hopper.

AUGER ON/OFF
SELECT A KEY

25. If the ▼ and ▲ keys are pressed the hopper status will toggle between “ON” and “OFF”.

AUGER
#-- IS ON/OFF

26. *DUMP VALVE STATUS*: Pressing any of the *Dispense* keys will cause the *Dispense* LED's of the corresponding Dump Valve to blink and the LCD screen will display the status for the indicated Dump Valve.

DUMP VALVE
SELECT A KEY

27. If the ▼ and ▲ keys are pressed the Dump Valve will toggle between "ON" and "OFF".

DUMP #--
IS ON/OFF

28. *MIXER STATUS*: Pressing any of the *Dispense* keys will cause the *Dispense* LED's of the corresponding Mixer Motor to blink and the LCD screen will display the status for the indicated Mixer Motor.

MIXER
ON/OFF

29. If the ▼ and ▲ keys are pressed the Mixer Status will toggle between "ON" and "OFF".

MIXER #--
ON/OFF

30. *PRODUCT SENSOR LOCATION*: Pressing any of the *dispense* keys will cause the *Dispense* LED's of the corresponding Product Sensor to blink.

PRODUCT SENSOR
SELECT A KEY

31. *PRODUCT SENSOR READING*: Pressing a *lighted dispense* key will cause the LCD screen to display the status for the indicated hopper.

PRODUCT SENSOR
#-- OFF/FULL

32. *PRODUCT SENSOR STATUS*: Pressing a *lighted dispense* key will cause the LED screen to display if it is turned "OFF" on "ON". If the ▼ and ▲ keys are pressed, the Product Sensor will toggle between "OFF" and "ON".

PRODUCT SENSOR
ON/OFF
SELECT A KEY

PRODUCT SENSOR
ON/OFF
#-- IS ON/OFF

33. *LOW PRODUCT WARNING*: If the ▼ and ▲ keys are pressed the Low Product Warning Screen will toggle between "ON" and "OFF".

LOW PRODUCT WARNING
ON/OFF

34. *LOW PRODUCT LOCKOUT*: If the ▼ and ▲ keys are pressed the Low Product Lockout will toggle between "ON" and "OFF".

LOW PRODUCT LOCKOUT
ON/OFF

35. *BLOWER DIAGNOSTICS*: If the ▼ and ▲ keys are pressed the Blower Diagnostics will toggle between "ON" and "OFF".

BLOWER
DIAGNOSTICS
ON/OFF

36. *OVERFLOW SENSOR MODE*: If the ▼ and ▲ keys are pressed the Display will toggle between "Level Probe" and "Thermister".

OVERFLOW SENSOR
LEVEL PROBE

OVERFLOW SENSOR
THERMISTER

37. *DISPLAYED UNITS*: If the ▼ and ▲ keys are pressed the Display will toggle between "English" and "Metric".

DISPLAYED UNITS
ENGLISH

DISPLAYED UNITS
METRIC

38. *CLOCK SETTINGS*: All dispense Keys will light. Any key pressed will activate each of the 7 variables required to set the time of day. Each can be adjusted by pressing the ▼ and ▲ keys.

CLOCK SETTINGS
XXX XXX

39. *FACTORY DEFAULT SETTINGS*: LCD Screen will display the following:

DEFAULT VALUES
ARE YOU SURE

40. Pressing the ▼ and ▲ keys simultaneously will cause all parameters to revert to the Default values and the LCD Screen to display the following:

DEFAULT VALUES
COMPLETED/CLEARED

DEFINITION OF "SYSTEM ERROR" SCREENS AND TROUBLESHOOTING

IF ANY OF THESE ERROR SCREENS COME UP ALSO CHECK THE SAFETY RELAY IN ADDITION TO THE COMPONENT IN QUESTION. SEE RELAY TEST.

1. Over Temperature Error Screen

Definition - This screen is displayed and the system is shut down when the present water temperature is sensed higher than 208 °F.

Possible Causes: *Invalid required Water Temperature or Faulty Water Temperature Sensor.*

!SYSTEM ERROR!
OVER TEMPERATURE

2. Water Overflow Error Screen

Definition - This screen is displayed and the system is shut down when the OT/OF Sensor is detecting a water level height that has risen above the water level probe.

Possible Causes: *Faulty fill Solenoid or faulty / disconnected Level Sensor.*

!SYSTEM ERROR!
WATER OVERFLOW

3. No Fill Response Error Screen Definition - This screen is displayed and the system is shut down when the Fill Solenoid has been continuously energized (open & filling) for more than five minutes during the first fill or more than 30 seconds thereafter.

Possible Causes: *Water supply is turned OFF or faulty / disconnected Level Sensor.*

!SYSTEM ERROR!
NO FILL RESPONSE

4. No Fill Request Error Screen Definition - This screen is displayed and the system is shut down when the Fill Solenoid has not been energized, even though enough water has been dispensed to trigger a refill cycle.

Possible Causes: *Defective dump valve, Faulty level Sensor.*

!SYSTEM ERROR!
NO FILL REQUEST

5. No Temperature Response Error Screen

Definition - This screen is displayed and the system is shut down when the Water Heater has been continuously energized (heating) for more than 60 minutes. without reaching set point temperature.

Possible Causes: *faulty/disconnected Level Sensor, faulty Water Temperature Sensor, or faulty Water Heater.*

!SYSTEM ERROR!
NO TEMP RESPONSE

6. Water Heater Error Screen

Definition - This screen is displayed and the system is shut down when the required status (ON/OFF) of the Water Heater does not match the sensed status for more than two seconds.

Possible Causes: *faulty/disconnected Water Heater, faulty/disconnected Triac, or faulty/disconnected Safety Relay.*

!SYSTEM ERROR!
WATER HEATER

7. Fill Solenoid Error Screen - Water Inlet Valve

Definition - This screen is displayed and the system is shut down when the required status (ON/OFF) of the Fill Solenoid does not match the sensed status for more than two seconds.

Possible Causes: *Faulty/disconnected Fill Solenoid or faulty/disconnected Safety Relay.*

!SYSTEM ERROR!
FILL SOLENOID

8. Auger Motor Error Screen

Definition - This screen is displayed and the **entire system is inoperable** when the required status of the Auger Motor (identified by @) does not match the sensed status for more than two seconds.

Possible Causes: *Faulty/disconnected Auger Motor.*

!SYSTEM ERROR!
AUGER MOTOR # --

9. Dump Solenoid Error Screen - Dispense Valve Error Screen

Definition - This screen is displayed and the **entire system is inoperable** when the required status of the Dump Solenoid (identified by @) does not match the sensed status for more than two seconds.

Possible Causes: *Faulty/disconnected Dump Solenoid [Dispense Valve] or faulty/disconnected Safety Relay.*

!SYSTEM ERROR!
DUMP VALVE # --

10. Mixer Motor Error Screen

Definition - This screen is displayed and the **entire system is inoperable** when the required status (ON/OFF) of the Mixer Motor (identified by @) does not match the sensed status for more than two seconds.

Possible Causes: *Faulty/disconnected Mixer Motor or faulty/disconnected Safety Relay. If Mixer Motor or Relay check out good, manually check for loose connections or defective parts on all 120V ac circuits including: fuse, fuse holder, transformer, hi-limit, and harness.*

!SYSTEM ERROR!
MIXER MOTOR # --

Note: IF either the Auger Motor, or Mixer Motor, or Solenoid Error Screen appear: The entire system is inoperable this means that one of either the Auger Motor, or Mixer Motor, or Solenoid [Dispense Valve] is **not** functional while that Hopper Status in **ON**. **To continue operating the other Hoppers: Go into Program Mode** [by pressing simultaneously the Rinse and Stop Button], Press RINSE to get the HOPPER STATUS screen, Press ▼ or ▲ Button to set the non-functional HOPPER STATUS to **OFF**; Wait at least 10 sec., then Exit program. Reset Power Switch [OFF and ON].

11. Temperature Sensor Error Screen

Definition - This screen is displayed when no reading is being received from the Temperature Thermister.

Possible Causes: *Faulty/disconnected Temperature Thermister.*

!SYSTEM ERROR!
TEMP SENSOR

12. Over Temperature / Over Flow Error Screen

Definition - This screen is displayed and the system is shut down when the present water temperature is sensed higher than 208 °F.

Possible Causes: *Faulty/disconnected Over-Temperature/Over-Flow Sensor.
Incorrect setting of overflow sensor mode.*

!SYSTEM ERROR!
OT/ OF SENSOR

13. Safety Relay Open

Definition - This screen is displayed when something is causing the Safety Relay to open and disconnect power to the machine.

Possible Causes: *Faulty/disconnected Safety Relay; Faulty/disconnected Transformer, Blown Fuse, Hi-limit sensing an overheat condition in the water tank.*

!SYSTEM ERROR!
SAFETY RELAY OPEN

14. Component Ground

Definition - Board's sensing some component grounding to chassis.

Possible Causes: *Faulty Thermister, Faulty Auger Motor, Loose wiring inside machine compartment.*

!SYSTEM ERROR!
COMPONENT GROUND

15. Communications Error Screen

Definition - This screen is displayed and the system is shut down when the Communications Link between the Display Board and the Control Board has been interrupted for more than five seconds and then re-established.

Possible Causes: *Faulty connection between the Display Board and the Control Board.*

!SYSTEM ERROR!
COMMUNICATIONS

16. Communications Failure Screen

Definition - This screen is displayed and the system is shut down when the Communications Link between the Display Board and the Control Board has been interrupted for more than five seconds.

Possible Causes: *Faulty connection between the Display Board and the Control Board.
Incorrect software in Main Control Board or in Display Board*

!SYSTEM ERROR!
COM FAILURE V#.##

17. Control Board Error

Definition - This screen is displayed and the system is shut down when the Control Board does not sense a response from one of the following components: Mixer Mtr. (M-1 thru 3) Dispense Value (D-1 thru 3), or Auger Motor (A-1 thru 5).

Possible Causes: *Faulty Component, Faulty Connection of the indicated component, Faulty Main Control Board.*

!SYSTEM ERROR!
CTL BOARD (M1-3)
(D1-3)
(A1-5)

SANITIZING, CLEANING AND REFILLING HOPPERS

Sanitizing: All food dispensing units should be sanitized periodically. All parts to be sanitized must be cleaned first.

To prepare a sanitizing solution: ADD 2 TSP. OF LIQUID CLOROX BLEACH (5.25% CONCENTRATION) TO 1 GALLON OF WATER AT ROOM TEMPERATURE (70°- 90°F).

Note: Always start with an unopened bottle of Clorox Bleach since the solution from an opened bottle has a short life span.

- Soak all parts for a minimum of 3 min. in the sanitizing solution.
- Let all sanitized parts drain and dry naturally. DO NOT WIPE THEM DRY.
- Before using the sanitized unit (or parts) with food stuffs, rinse all parts thoroughly with water.

Water pipe connecting and fixtures directly connected to a potable water supply shall be sized, installed, and maintained in accordance with Federal, State, and Local codes (section 7).

Cleaning

1. Turn the power switch to OFF.
2. Remove the drip tray with grill and empty the contents.
3. Wash and let dry the tray and grill (use a mild dishwasher detergent).
4. Wash and let dry the dispense area.
5. Turn the power switch to ON.

Cleaning the Hoppers

1. Open the cabinet door.
2. Take the hopper out of the cabinet.
3. Pull off the elbow chute and remove the hopper cover.
4. Unscrew the auger gear CW while holding steady the auger inside the hopper. Take out the auger, agitator wheel, and spring.
5. Rinse each item thoroughly.
6. Let dry all items and reassemble.

Filling the Hoppers

1. Open the cabinet door.
2. Fill each hopper with the correct product.
3. Reposition hoppers in the hopper compartment, making sure the hoppers are properly seated.

Flushing the Whipper Chamber

1. Complete Rinse is initiated by simultaneously pressing Blue Rinse Button and any Drink Dispense Buttons.

Removing and Cleaning the Whipper Chambers (See Illustration)

1. Remove the dispense cap by pulling it forward and at the same time twisting it clockwise.
2. Grab and pull the mixing bowl out of the mixing bowl socket.
3. Grab and twist the whipping chamber clockwise and pull it off the mounting plate.
4. Pull the Whipper blade off the motor shaft. Notice the flat keyway on the shaft and the matching keyway inside the Whipper blade shaft.

It is important that these two keyways are lined up when re-assembling the components.

5. Twist the mounting plate clockwise and pull it off the motor shaft.
6. Slip off the o-ring from the Whipper chamber mounting plate and clean o-ring and o-ring seat.

TROUBLE SHOOTING GUIDE

WARNING: To reduce the risk of electrical shock unplug the dispenser power cord before repairing or replacing any internal components of the unit.. Before any attempt to replace a component be sure to check all electrical connections for proper contact

PROBLEM	PROBABLE CAUSE	REMEDY
1. Light Display not lit. No power.	a) Dispensing unit unplugged b) No power from Main Board or from Power Switch. c) Defective Bulb d) Loose Bulb in socket. e) Defective Ballast.	a) Reconnect dispensing unit b) Check for loose wire to Main Board or to Power Switch. c) Replace Bulb. d) Make sure bulb is seated properly in socket. e) Replace Ballast
2. No water when Rinse Switch is ON.	a) Water supply OFF. b) Clogged inlet screen (Water Inlet Valve). c) Inoperative Water Inlet Valve. d) Loose electrical connection.	a) Turn water ON. b) Disconnect water line and clean inlet screen. c) Check connection, if needed replace Valve. d) Check all electrical connections.
3. No product when Dispense Button is pressed	a) No product in Hopper. b) Auger not working. c) Damaged, loose, or missing Agitator Gear. d) Inoperative Auger Motor. e) Hopper outlet clogged f) Faulty Coupling.	a) Add product. b) Engage Hopper/Nut to Motor Gear (see III. E). c) Replace Agitator Gear (see III. E). d) Check connections of Motor, if needed replace such components. e) Clean Hopper and check Cartridge Heater. f) Replace damaged Coupling components.
4. Water does not shut off. Water keeps dispensing.	a) Leaking Solenoid [Water Inlet Valve]. b) Inoperative Switches on Touch Pad. c) Inoperative Rinse Switch – Touch Pad d) Clogged/stuck Water Dispense Valve	a) Clean/check fittings of Valve. Replace Valve if needed. See "Water Inlet Valve Test" b) Check Touch Pad connections. Replace Touch Pad if needed. d) Clean/unclog Water Dispense (Dump) Valve. Replace Dispense Valve if inoperative.
5. No water is going into tank at all.	a) Water Inlet Valve malfunction. b) Probe malfunction.	a) Check Solenoid valve. Replace if necessary. See "Water Inlet Valve Test" b) Check Probe. Replace if necessary. See "Probe Test".
6. Water will not stop flowing into tank.	a) Water Level Probe Malfunction. b) Solenoid (Water Inlet Valve) Malfunction.	a) Check Probe. Replace if necessary. See "Probe Test" b) Check Solenoid. Replace if necessary. See "Water Inlet Valve Test"
7. Water is not heating up in the water tank.	a) Temperature setting is incorrect. b) Loose connection to Heating element c) Heater is burned out or defective.	a) Set Temperature at 195°F – See Programming Instructions b) Make sure all wires are tight. c) Replace the Heater.
9. Water drips from mixing chamber	a) Leaking Water Dispense Valve b) Too much water in tank. c) Mixing Chamber clogged. d) Water Valve blocked by scales.	a) Replace Water Dispense (Dump) Valve b) Dispense some water from tank. c) Clean Mixing Chamber. d) Replace or clean Valve seat.
10. Cold drink.	a) Run out of hot water b) Temperature setting is incorrect. c) Loose electrical connection. d) Bad Heating Element or Heater is burned out.	a) Allow time for water in tank to heat after filling. b) Set temperature at 195°F. (See Programming Instructions) c) Check all electrical connections for contact. d) Replace Heater. (See Item 11 on Tank Assy. ILL. F).
11. Drink too strong.	a) Water flow too low b) Product throw too high	a) Adjust water flow rate (see III. B) b) Adjust Gram Throw. (see Programming Instructions)
12. Drink too weak.	a) No product in hopper b) Product throw too low c) Water flow too high	a) Add product b) Adjust Gram Throw (see Programming Instructions) c) Adjust water flow rate (see III. B)
13. Drink not whipped.	a) Whipper Blade missing. b) Loose electrical connection to motor. c) Whipper Motor defective.	a) Replace Whipper Blade b) Check electrical connections to motor. c) Replace Whipper Motor.

14. Dispenser repeats cycle	a) Touch Pad defective. b) Power [Dispense] Relay stuck.	a) Replace Touch Pad. b) Replace Relay.
15. Noise coming from mixing chamber	a) Whipper blade not properly aligned or missing.	a) Check blade alignment, if needed replace blade and mixing chamber.
16. Grinding noise coming from unit	a) Hopper not properly engaged in back, or Hopper not seated properly	a) Check the mating between the auger motor's gear and hopper's coupling/nut. Check also pin in base. Pin must be dropped into hole in base.
17. Banging or clicking noise coming from hoppers	a) One or more Hoppers are empty or almost empty.	a) Fill Hoppers with product.



COMPONENTS TESTS

1) Water Inlet Valve Test

Turn power off. If the water level rises inside the tank, the Water Inlet Valve is leaking. Disconnect wires from the Water Inlet Valve coil and connect a 2 wire line cord to the terminals. Plug it into a 115V outlet. If water flows in and stops when you pull it out, the Valve is working fine. Repeat this test a few times. The problem may be in the Probe. If the water does not flow in when the cord is plugged into an electrical outlet, the Solenoid coil may be damaged, opened or the valve may have an obstruction preventing the water from flowing in. Clean or replace it.

A Check Valve is installed to prevent backflow.

To check proper function of Check Valve, disconnect water line from the Check Valve, check for dripping from the disconnected end of the Check Valve. If it leaks replace it.

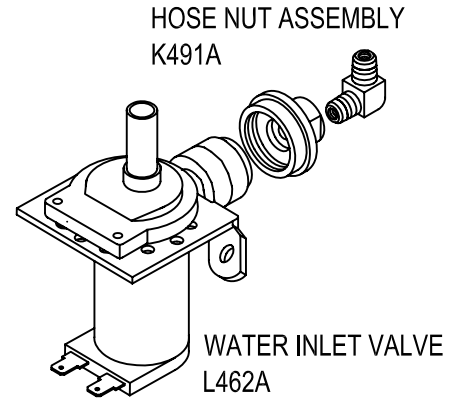

2) Water Level Probe Test

If there is a lack of water, you will get an error message on the LCD window.

Check the probe as follows:

Turn on the power and water supply. Check inside the tank to make sure the water is not touching the Probe. Pull the wire terminal off the Probe rod. If water starts flowing into the tank, the Probe may be grounded, due to excessive liming. Check with Ohm meter. Clean or replace.

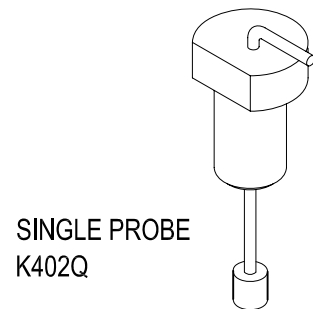

3) Safety Relay Test

Turn Power Switch ON.

Measure Voltage across Output "COM" to Ground. Should read 120 V.

Measure Voltage across Input "N.O." to Ground. Should read 120 V.

Measure Voltage across Input to Coil . Should read 24 VDC.

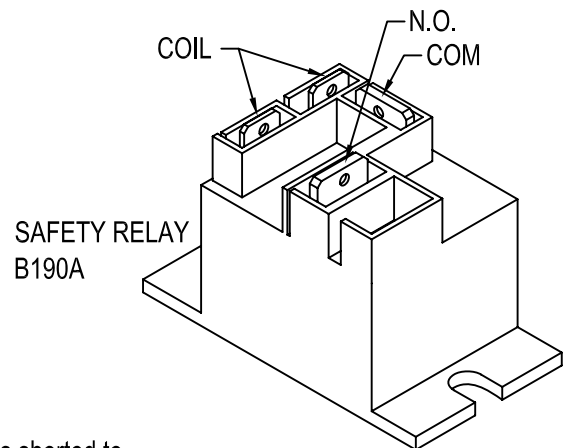

4) Thermister Test

Thermister senses the water temperature in the tank. If either of the two leads is shorted to the metal housing, an error message will result. Check with an ohm meter if either lead is grounded. To check calibration of the thermister, use an Ohm meter to check resistance values at the below temperature.

70° F	measures	10.0 - 12.0 ohms
190° F	measures	1.0 - 2.0 ohms

If the above values vary 2 Ohm or more, replace the thermister

COMPONENTS TESTS

1) Water Inlet Valve Test

Turn power off. If the water level rises inside the tank, the Water Inlet Valve is leaking. Disconnect wires from the Water Inlet Valve coil and connect a 2 wire line cord to the terminals. Plug it into a 115V outlet. If water flows in and stops when you pull it out, the Valve is working fine. Repeat this test a few times. The problem may be in the Probe. If the water does not flow in when the cord is plugged into an electrical outlet, the Solenoid coil may be damaged, opened or the valve may have an obstruction preventing the water from flowing in. Clean or replace it.

A Check Valve is installed to prevent backflow.

To check proper function of Check Valve, disconnect water line from the Check Valve, check for dripping from the disconnected end of the Check Valve. If it leaks replace it.

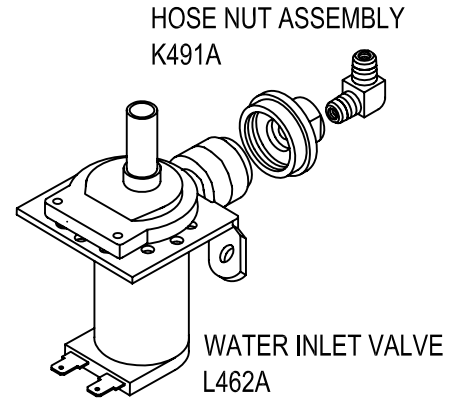

2) Water Level Probe Test

If there is a lack of water, you will get an error message on the LCD window.

Check the probe as follows:

Turn on the power and water supply. Check inside the tank to make sure the water is not touching the Probe. Pull the wire terminal off the Probe rod. If water starts flowing into the tank, the Probe may be grounded, due to excessive liming. Check with Ohm meter. Clean or replace.

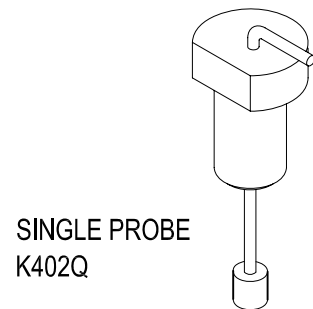

3) Safety Relay Test

Turn Power Switch ON.

Measure Voltage across Output "COM" to Ground. Should read 120 V.

Measure Voltage across Input "N.O." to Ground. Should read 120 V.

Measure Voltage across Input to Coil . Should read 24 VDC.

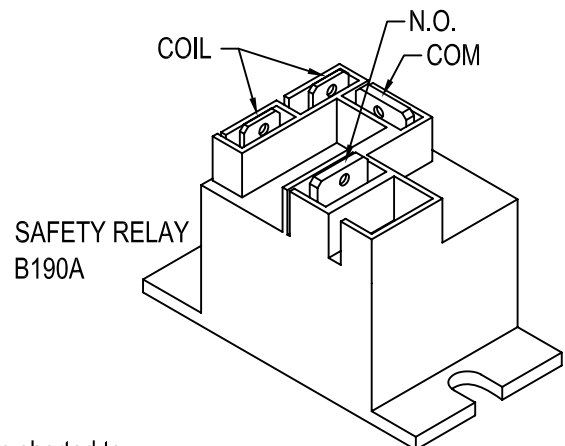

4) Thermister Test

Thermister senses the water temperature in the tank. If either of the two leads is shorted to the metal housing, an error message will result. Check with an ohm meter if either lead is grounded. To check calibration of the thermister, use an Ohm meter to check resistance values at the below temperature.

70° F	measures	10.0 - 12.0 ohms
190° F	measures	1.0 - 2.0 ohms

If the above values vary 2 Ohm or more, replace the thermister

PREVENTIVE MAINTENANCE

RECOMMENDED PREVENTIVE MAINTENANCE

1) CHECK ALL DISPENSE VALVES FOR LIME BUILD-UP.

Drain The Water Tank To Just Below The Level Of The Dispense Valves.

Remove The Valves And Clean. (You Can Take These Valves Apart By Hand As Shown).

Replace The Assembly As Needed (L467A).

Replace The Valve Into The Tank And Refill tank.

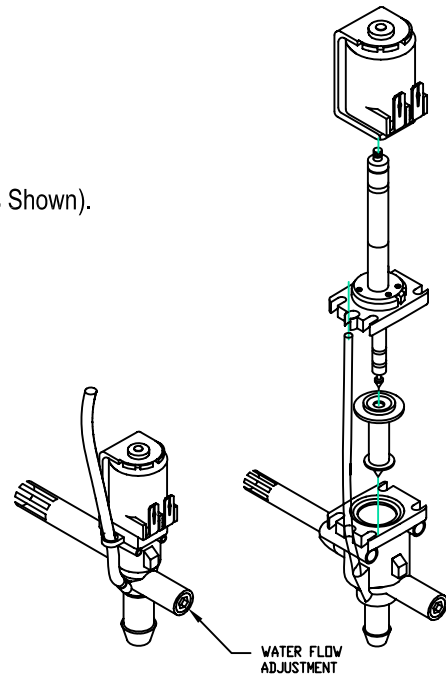

2) To Rebuild Dispense Valves

Order KIT # M491Q

3) CHECK ALL CHAMBER MOUNTS FOR SIGNS OF WEAR

- A. Product or water running down the front of the Unit.
- B. Product built up on the back of Chamber Mount.
 - Remove Chamber Mount.
 - Clean and re-lubricate Motor Shaft using food grade lubricant only
 - Replace with new Chamber Mount.

4) CLEAN OUT VENT MOTOR, TROUGH AND TUBING.

Remove two screws holding trough in place.

Clean, and replace trough drawer.

Remove hose assembly from the fan.

Clean out and replace.

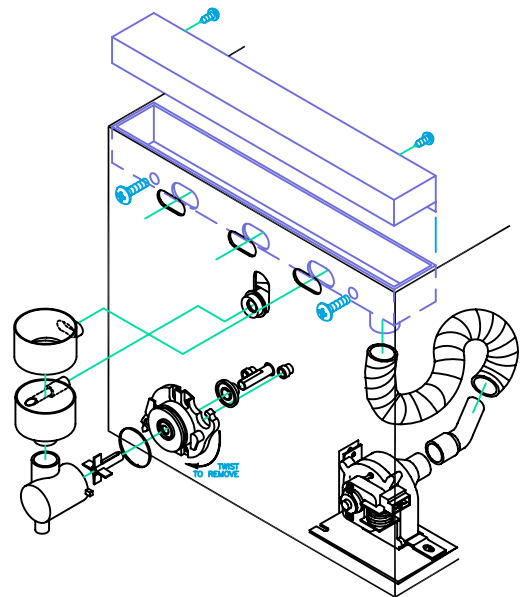

HOT WATER TANK ASSEMBLY (P/N SW33C)

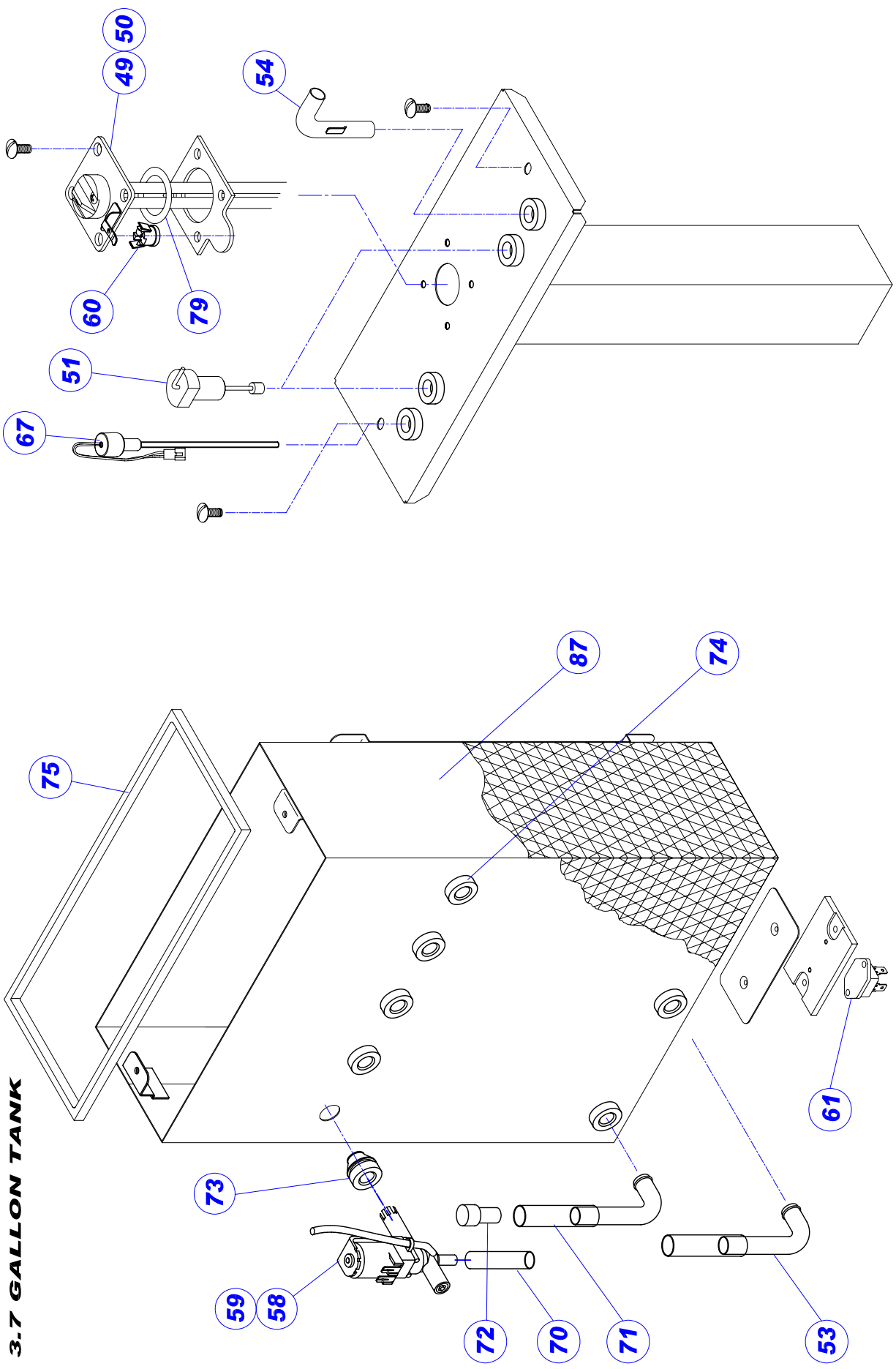

HOPPERS and DISPENSING CHAMBERS FOR REPLACEMENT

HOPPER ASS'Y (2 LB, 13.125"HEIGHT x 1.75"WIDTH) W/NYLON AUGER AND DISPENSING CHAMBER COMPONENTS - FLAVOR SIDE

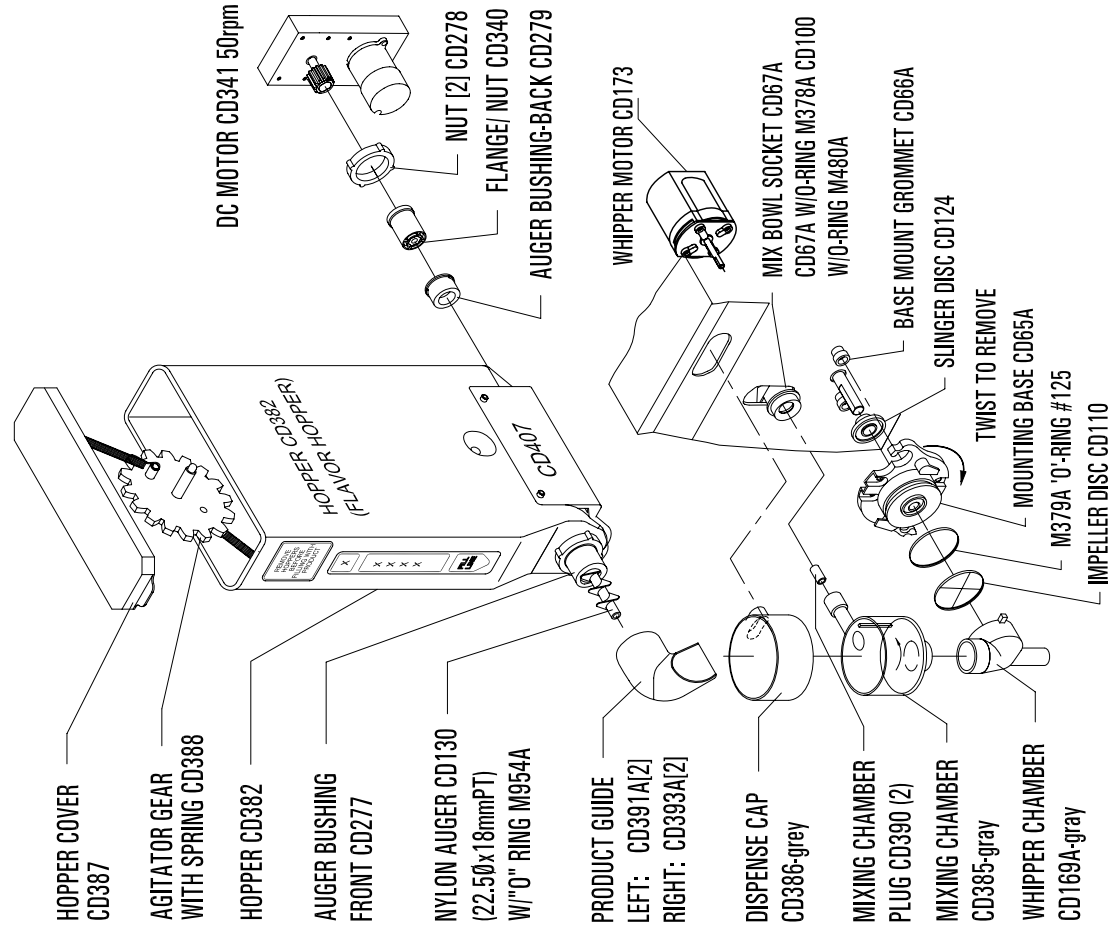

HOPPER ASS'Y (10 LB, 13.125"HEIGHT X 4.5"WIDTH) W/NYLON AUGER AND DISPENSING CHAMBER COMPONENTS - MILK SIDE

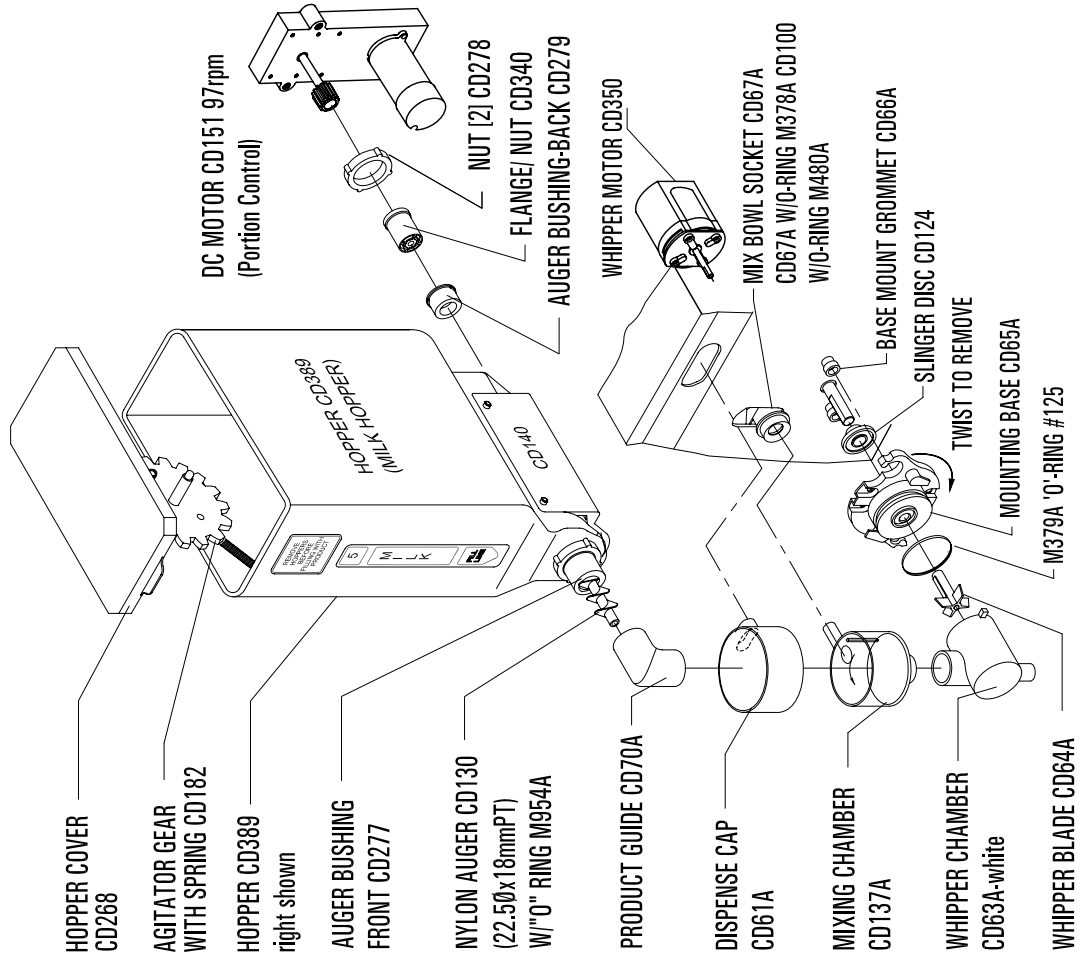

HOPPERS and DISPENSING CHAMBER FOR HC MODELS

**HOPPER ASSY CD338 (5 LB, 13.560" HEIGHT x 2.5" WIDTH)
W/ NYLON AUGER
"USED ON GB5-MF-HC-IT ONLY"**

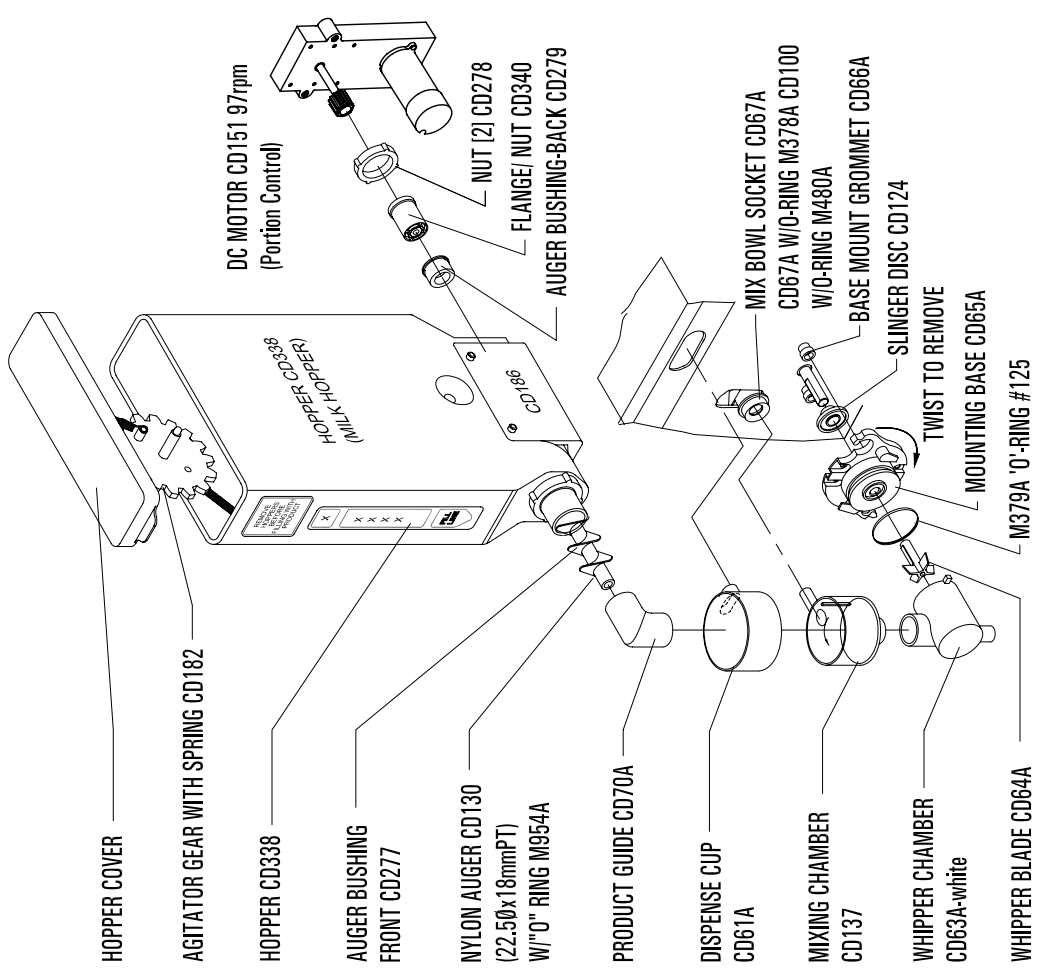

GB5MF-IT BODY PARTS

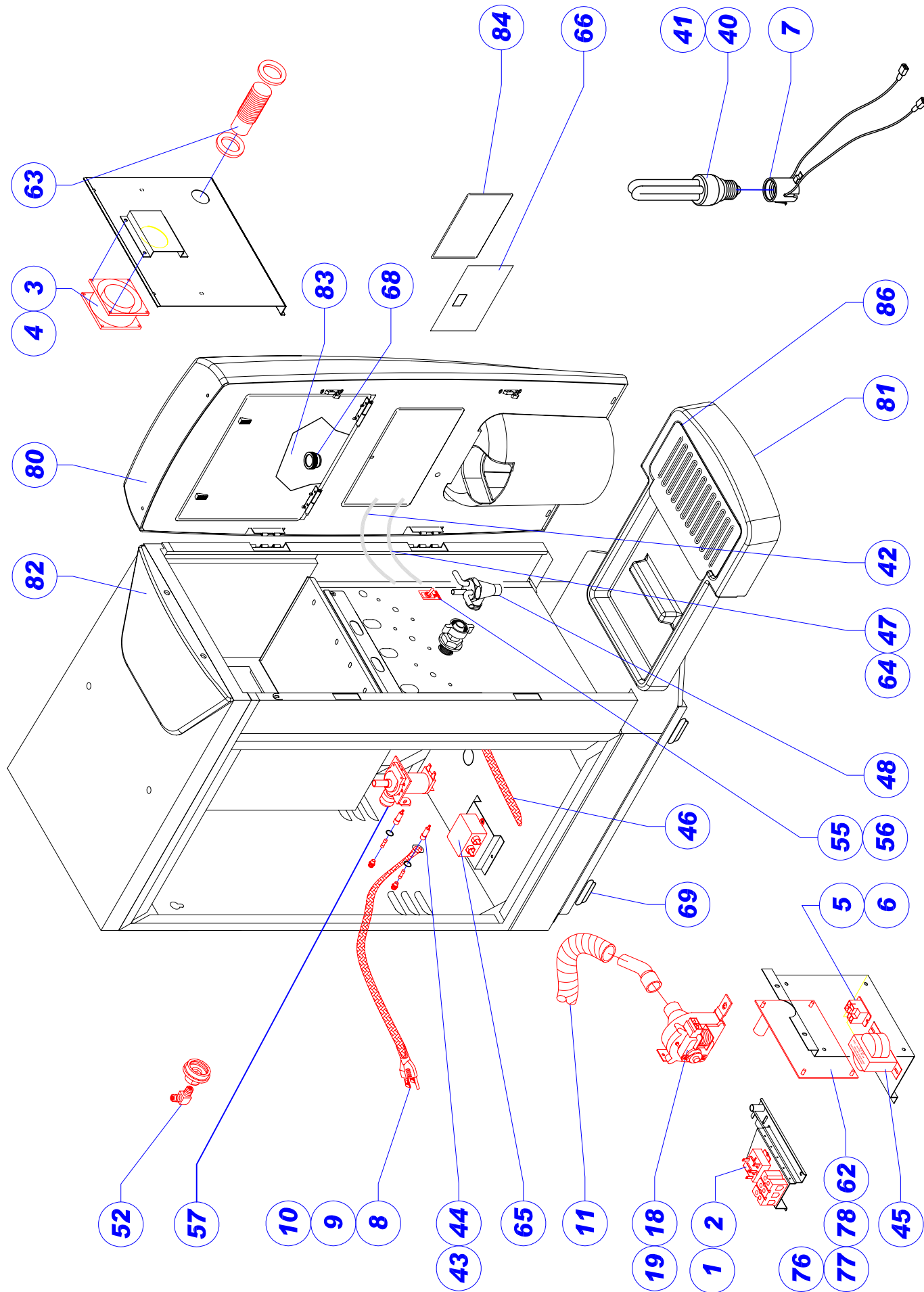

MODEL: GB5MF-IT

ITEM	PART #	DESCRIPTION	QTY 120V	QTY 240V
1	B138A	RELAY - 120VAC (SPDT 15A)	1	
2	B172A	RELAY - 240VAC (SPDT 15A)		1
3	B176A	FAN, AXIAL 120V	1	
4	B202A	FAN, AXIAL 240V		1
5	B190A	SAFETY RELAY 24 VDC S.P.S.T.	1	
6	B191A	SAFETY RELAY 24VDC D.P.S.T.		1
7	B216A	LAMP HOLDER	1	1
8	C032A	LINE CORD W/ PLUG, 15AMP 120V, NEMA 5-15P	1	
9	C112A	LINE CORD, 16AMP 220V (EXPORT ONLY)		
10	C770Q	LINE CORD W/ PLUG, 15 AMP 240V, NEMA 6-15P		1
11	CA214	VACUUM HOSE	1	1
12	CD110	IMPELLER DISC	2	2
13	CD124	SLINGER DISC	3	3
14	CD130	AUGER, NYLON	1	1
15	CD151	AUGER MOTOR, 24V DC, 97 RPM	1	1
16	CD341	GEAR MOTOR, 24V DC, 50 RPM, PLASTIC	4	4
17	CD409	AUGER DRIVE SHAFT 21MM FOR CD341	4	4
18	CD56A	BLOWER FAN 120V	1	
19	CD166	BLOWER FAN 240V		1
20	CD350	WHIPPER MOTOR, AC 120V	1	
21	CD168	WHIPPER MOTOR, SHORT SHAFT 240V		2
22	CD169	WHIPPING CHAMBER (GRAY COLOR)	2	2
23	CD173	WHIPPER MOTOR, SHORT SHAFT, 120V	2	
24	CD399	WHIPPER MOTOR, AC 240V		1
25	CD61A	DISPENSE CAP	1	1
26	CD137	MIXING CHAMBER	1	1
27	CD353	WHIPPER BLADE	1	1
28	CD385	MIXING CHAMBER (GRAY COLOR)	2	2
29	CD386	DISPENSE CAP (GRAY COLOR)	2	2
30	CD390	FLOW RESTRICTOR, MIXING BOWL	2	2
31	CD391	PRODUCT GUIDE (LEFT)	2	2
32	CD393	PRODUCT GUIDE (RIGHT)	2	2
33	CD382	HOPPER, ASSY W/ NYLON AUGER, SMALL	4	4
34	CD389	HOPPER, ASSY W/ NYLON AUGER, LARGE	1	1
34	CD338	HOPPER, ASSY W/ NYLON AUGER, "HC" ONLY	2	2
35	CD63A	WHIPPER CHAMBER	1	1
36	CD65A	CHAMBER MOUNT	3	3
37	CD66A	CHAMBER MOUNT GROMMET	6	6
38	CD67A	MIXING BOWL SOCKET	3	3
39	CD70A	PRODUCT GUIDE	5	5
40	CE80A	BULB, FLUORESCENT 18W, 240V		1
41	CE82A	BULB, FLUORESCENT 18W, 120V	1	
42	CH18A	CABLE, DOOR ASSEMBLY	1	1
43	CH246	FUSE (2 amp)	2	4
44	CH247	FUSE HOLDER	2	4
45	CH332	TRANSFORMER - 120V	1	

ITEM	PART #	DESCRIPTION	QTY 120V	QTY 240V
45	CH474	TRANSFORMER - 240V		1
46	CH376	MAIN HARNESS 120V	1	
46	CH448	MAIN HARNESS 240V		1
47	CH68A	DOOR CABLE (6 PIN) TO INTERFACE BOARD	1	1
48	D101Q	FAUCET ASSEMBLY	1	1
49	G266A	HEATER ELEMENT, 3000W, 240V, 16" LONG		1
50	G267A	HEATER ELEMENT, 1700W, 120V, 16" LONG	1	
51	K402Q	LIQUID LEVEL CONTROL SENSOR ASSY	2	2
52	K491A	WATER INLET CONNECTOR	1	1
53	K525A	ELBOW TUBE	2	2
54	K525Q	ELBOW-PROBE ASS'Y 1/2"OD w/ 1/4" TAB attached	1	1
55	L069A	TOGGLE SWITCH SPST (POWER)	1	
56	L299A	TOGGLE SWITCH DPST (POWER)		1
57	L462A	WATER INLET VALVE 120V	1	
57	L426A	WATER INLET VALVE 240V		1
58	L467A	DISPENSE VALVE 120 V	3	
59	L676A	DISPENSE VALVE 8mm 240 VAC		3
60	L656A	HI-LIMIT 200° CUTOFF	1	
61	L623A	HEATER TRIAC, 35 AMP	1	1
62	L782D	CONTROL BOARD (REPLACE L627D)	1	1
63	L641G	LEVEL SENSOR ASSEMBLY	1	1
64	L711A	FILTER SNAP ON	1	1
65	L728A	FILTER, CORCOM	1	1
66	L736A	DISPLAY BOARD	1	1
67	L742Q	THERMISTOR PROBE	1	1
68	M010A	KNOB, SMALL BLACK	1	1
69	M042A	LEGS 3/4" ADJ (SET OF 4)	1	1
70	M324A	SILICONE, PLATINUM 5/16 (FT)	5	5
71	M326A	SILICONE, PLATINUM 3/8 (FT)	5	5
72	M391A	DRAIN PLUG	1	1
73	M461A	SILICONE SEAL (12MM) / GROMMET .466 ID	9	9
74	M494A	GROMMET PLUG (.466 ID)	1	1
75	M500A	SILICONE BUTT SPLICED GASKET	1	1
76	M555A	SPACER RING	1	1
77	M686A	BOARD SUPPORT	4	4
78	M735A	NYLON SPACER, .563"L (FOR INTERFACE BD)	2	2
79	M773A	"O" RING	1	1
80	M985A	MOLDED DOOR	1	1
81	M990A	MOLDED DRIP TRAY	1	1
82	MA18A	PLASTIC TOP	1	1
83	MA27A	DURATRAN RETAINER	1	1
84	NM43B	TOUCHPAD	1	1
85	NM91A	OPERATION MANUAL	1	1
86	SV17A	GRILL, FOR MOLDED DRIP TRAY	1	1
87	SW33C	HOT WATER TANK, COMPLETE ASSEMBLY	1	1
88	SW33Q	HOT WATER TANK, WELDMENT	1	1

RECOMMENDED SPARE PARTS GB5MF-IT

PART No.	DESCRIPTION	QTY 120V	QTY 240V	MANUAL PAGE #
B138A	RELAY - 120VAC (SPDT 15A)	1		25
B172A	RELAY - 240VAC (SPDT 15A)		1	25
B176A	SQUARE AXIAL FAN 120V	1		25
B190A	SAFETY RELAY 24 VDC	1		25
B191A	SAFETY RELAY 24VDC D.P.S.T.		1	25
B202A	SQUARE AXIAL FAN 240V		1	25
B216A	LAMP HOLDER	1	1	25
CD110	IMPELLER DISC	2	2	24
CD124	SLINGER DISC	3	3	24
CD151	AUGER MOTOR 24V DC, 97 RPM	1	1	24
CD166	BLOWER MOTOR 240V, 50/60HZ		1	25
CD168	WHIPPER MOTOR, SHORT SHAFT 240V, 50/60HZ		2	24
CD169	WHIPPING CHAMBER (GRAY COLOR)	2	2	24
CD173	WHIPPER MOTOR, AC 120V (SHORT SHAFT)	1		24
CD61A	DISPENSE CAP	1	1	24
CD137	MIXING CHAMBER	1	1	24
CD341	GEAR MOTOR, 24V DC, 50 RPM	2	2	24
CD350	WHIPPER MOTOR, AC 120V (TWO FLATS)	1		24
CD353	WHIPPER BLADE W/ 2 FLATS	1	1	24
CD382	HOPPER, 1 3/4" W IDE W/ NYLON AUGER	2	2	24
CD385	MIXING CHAMBER (GRAY COLOR)	1	1	24
CD386	DISPENSE CAP (GRAY COLOR)	2	2	24
CD389	HOPPER, RIGHT 10 lbs	1	1	24
CD399	WHIPPER MOTOR, AC 240V (TWO FLATS)		1	24
CD409	DRIVE AUGER SHAFT 21MM FOR CD341	2	2	24
CD56A	BLOWER 120V	1		25
CD63A	WHIPPER CHAMBER	1	1	24
CD65A	CHAMBER MOUNT	1	1	24
CD66A	CHAMBER MOUNT GROMMET	2	2	24
CE80A	BULB, FLUORESCENT 18W TWIN TUBE 240V		1	25
CE82A	BULB, FLUORESCENT 18W TWIN TUBE 120V	1		25
CH246	FUSE (2 amp)	2	4	25
CH332	TRANSFORMER - 120V	1		25
CH474	TRANSFORMER - 240V		1	25
CH68A	DOOR CABLE (6 PIN) TO INTERFACE BOARD	1	1	25
G266A	HEATER ELEMENT, 3000W, 240V, 16" LONG		1	23
G267A	HEATER ELEMENT, 1700W, 120V, 16" LONG	1		23
K402Q	LIQUID LEVEL CONTROL SENSOR ASSY	1	1	23
L069A	TOGGLE SWITCH ON/OFF SPST [POWER]	1		25
L299A	TOGGLE SWITCH ON/OFF DPST [POWER]		1	25
L426A	WATER INLET VALVE 240VAC		1	25
L462A	WATER INLET VALVE 120VAC	1		25
L467A	DISPENSE VALVE 120 V, 7.5W 8mm (CLEAR SEAT)	1		23
L623A	HEATER TRIAC, 35 AMP	1	1	23
L627D	CONTROL BOARD, VER 8.10, (5 Chan. for units with Ser Nos up to N689056)	1	1	25
L641G	LEVEL SENSOR ASSEMBLY	1	1	25
L656A	HI-LIMIT 200° CUTOFF	1	1	23
L676A	DISPENSE VALVE 8mm 240 VAC		1	23
L736A	LCD DISPLAY BOARD	1	1	25
L742Q	THERMISTOR PROBE	1	1	23
L782D	CONTROL BOARD, (CONSULT FACTORY FOR PROPER VERSION #)	1	1	25
NM43G	TOUCHPAD	1	1	25

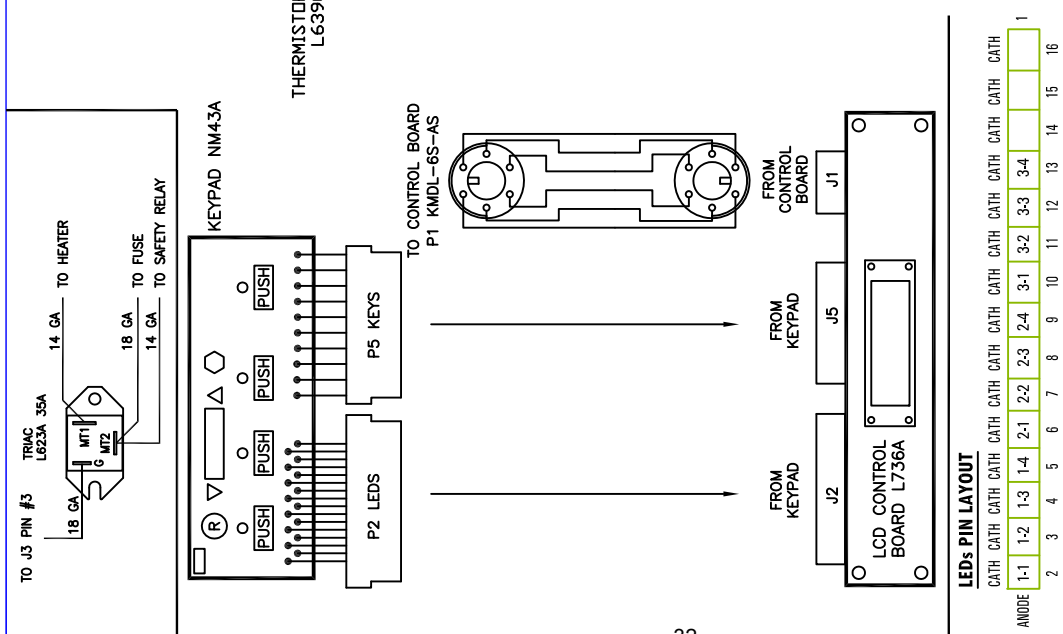
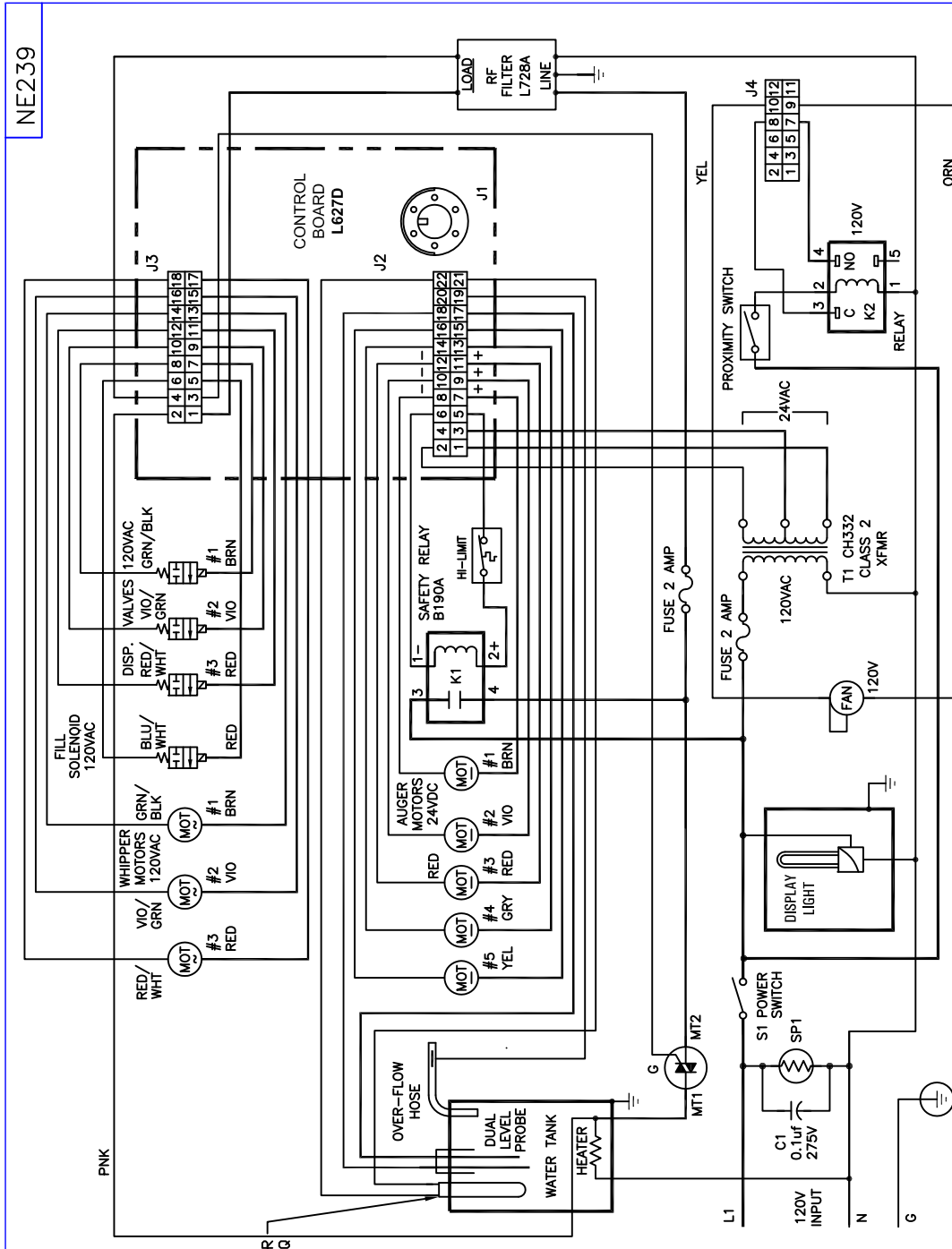

REV.	BY	DATE	DESCRIPTION
C	JL	03/26/01	ADDED OVER-FLOW HOSE CONNECTION TO PIN 19. REMOVED PIN 20 CONNECTION
B	GV	5/17/05	MODIFIED DISPLAY LIGHT

TOLERANCES UNLESS OTHERWISE SPECIFIED	FINISHED DIMENSIONS	DECIMAL	FRACTIONAL	ANGULAR	MATERIAL
±0.005	±1/64	±1/2°			

DO NOT SCALE THIS DRAWING

DATE	SCALE	DRAWN BY	APPROVED BY	PART NO.
10/20/04	1:1	M.M.		NE239

LEDs PIN LAYOUT

ANODE	1-1	1-2	1-3	1-4	2-1	2-2	2-3	2-4	3-1	3-2	3-3	3-4	4-1	4-2	4-3	4-4	5	6
CATH	1	2	3	4	5	6	7	8	9	10	11	12	13	14	15	16		

LED CIRCUIT POLARITY

ANODE - COMMON	CATHODE
R1	HW
R2	1-1
R3	1-2
R4	1-3
R5	1-4

120V

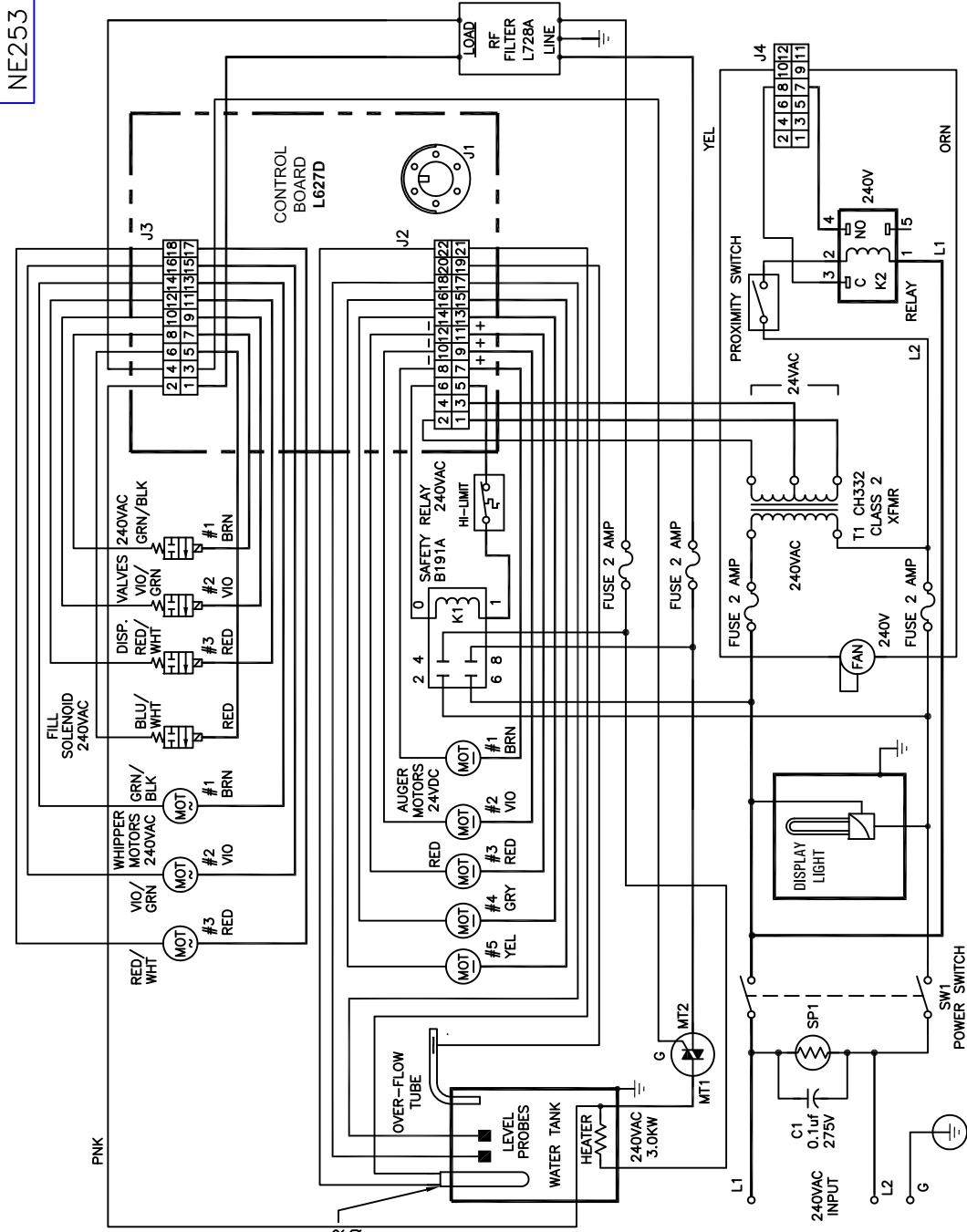

REV	BY	DATE	DESCRIPTION
B	J.L.	3/17/08	REVISED
A	G.V.	3/9/08	REVISED

TOLERANCES UNLESS OTHERWISE SPECIFIED	FINISHED DIMENSIONS	DECIMAL	FRACTIONAL	ANGULAR	MATERIAL
	✓	±.005	±1/64	±1/2°	

DO NOT SCALE THIS DRAWING	APPROVED BY	DATE	PART NO
		6/13/05	NE253

240V

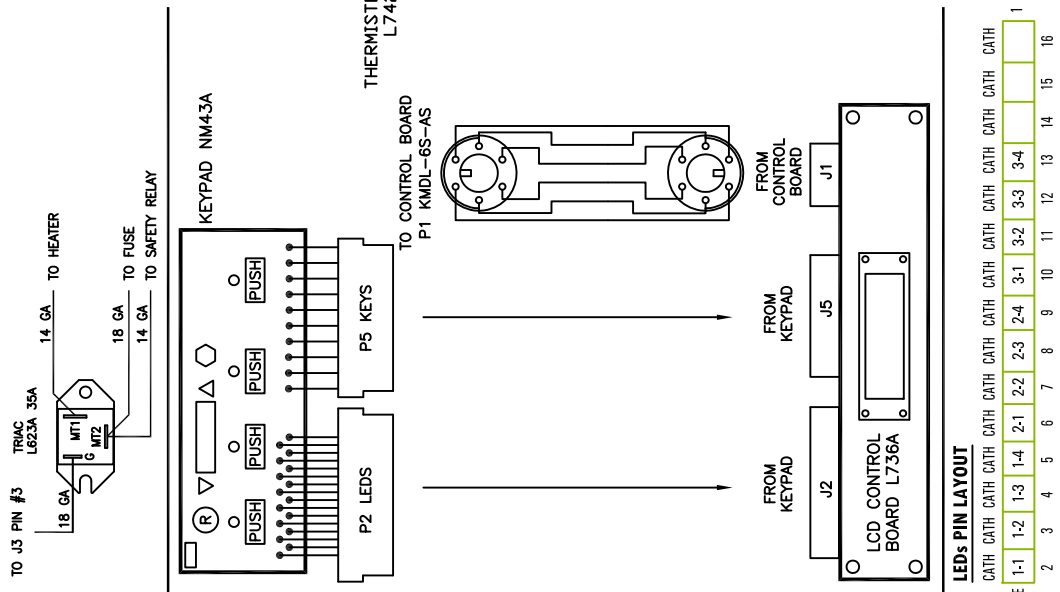

R1	R2	R3	R4	R5
1-1	1-2	1-3	1-4	1-5
2-1	2-2	2-3	2-4	2-5
3-1	3-2	3-3	3-4	3-5
4-1	4-2	4-3	4-4	4-5
5-1	5-2	5-3	5-4	5-5

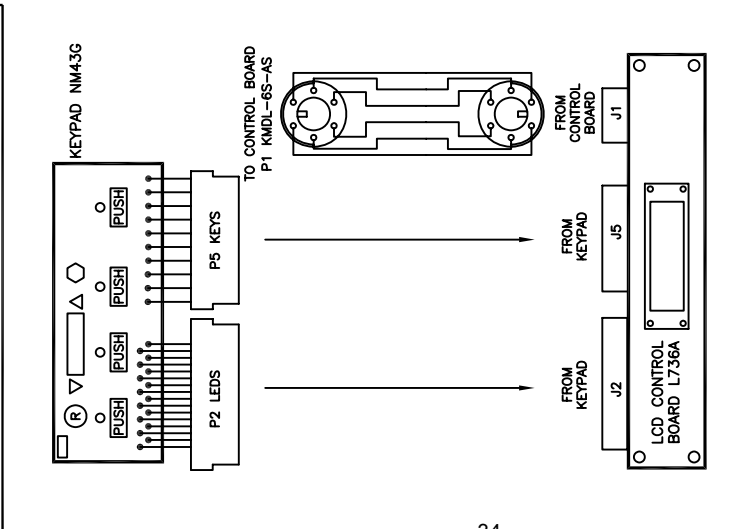
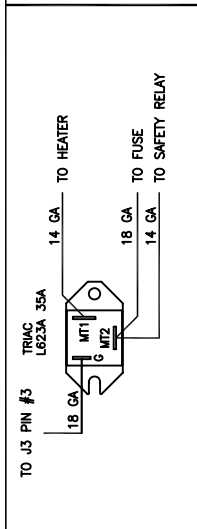
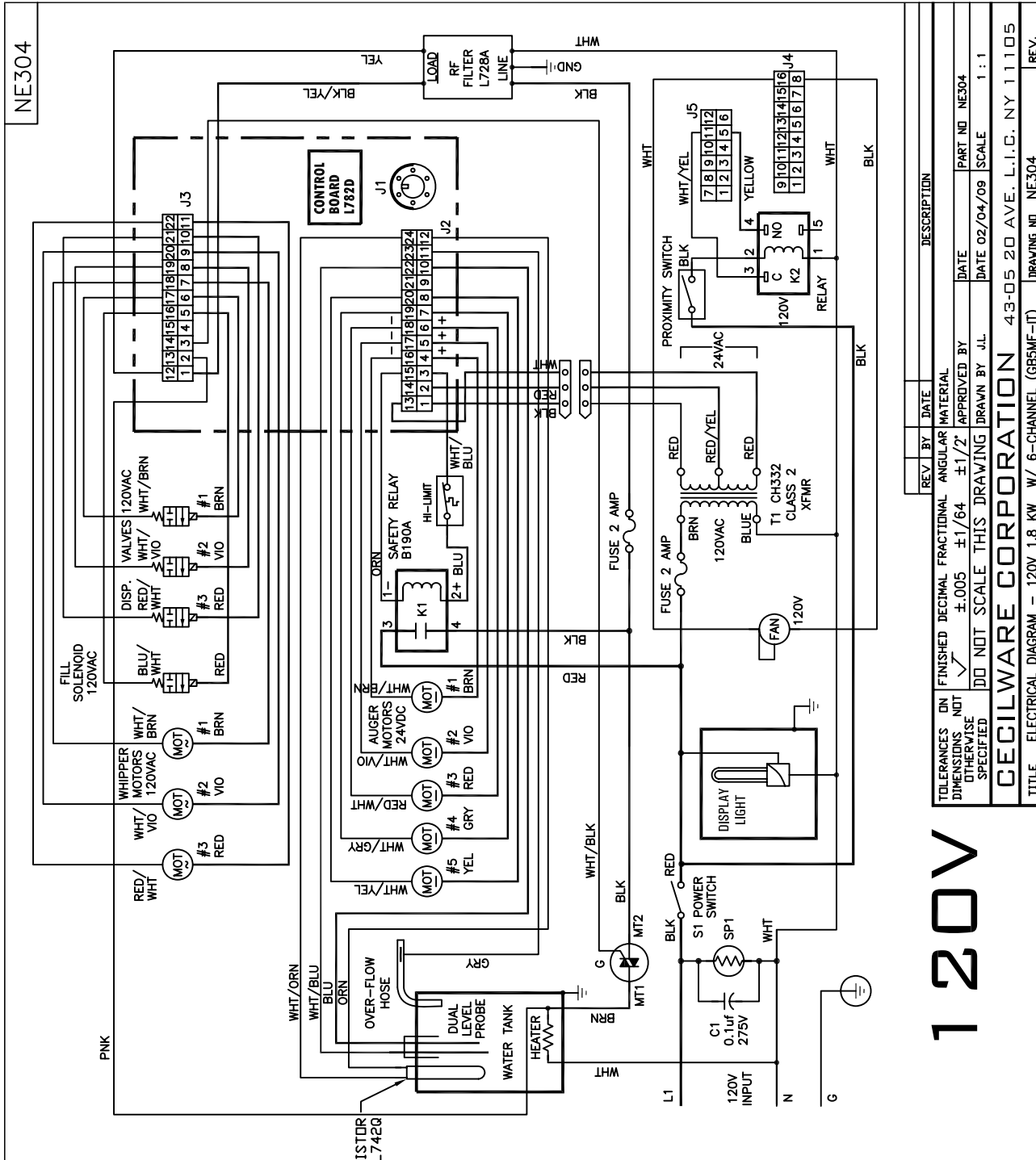

LEDs PIN LAYOUT

ANODE	1-1	1-2	1-3	1-4	2-1	2-2	2-3	2-4	3-1	3-2	3-3	3-4	CATH	1
CATH														

LED CIRCUIT POLARITY

ANODE - COMMON
CATHODE

R1	HW	C1	C2	C3	C4	C5
1						
2						
3						
4						
5						
6						
7						
8						
9						
10						

120V

REV	BY	DATE	DESCRIPTION
1	JL	02/04/09	SCALE 1:1

TOLERANCES ON DIMENSIONS UNLESS OTHERWISE SPECIFIED	FINISHED	DECIMAL	FRACTIONAL	ANGULAR	MATERIAL
	±.005	±1/64	±1/2'		

DATE	APPROVED BY	PART NO
02/04/09	JL	NE304

TITLE	ELECTRICAL DIAGRAM	W/ 6-CHANNEL (GBSMF-I)	43-05 20 AVE. L.I.C. NY 11105
REV.	NE304		

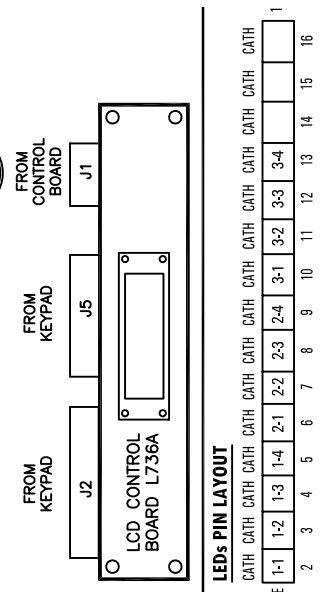
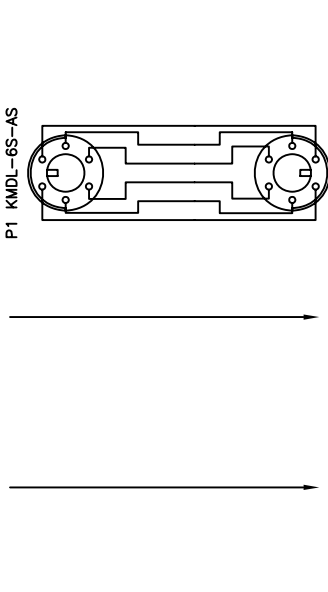
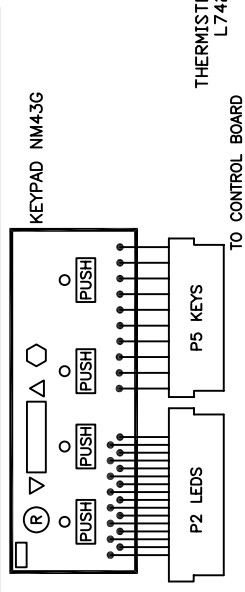
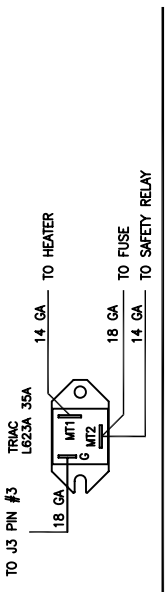
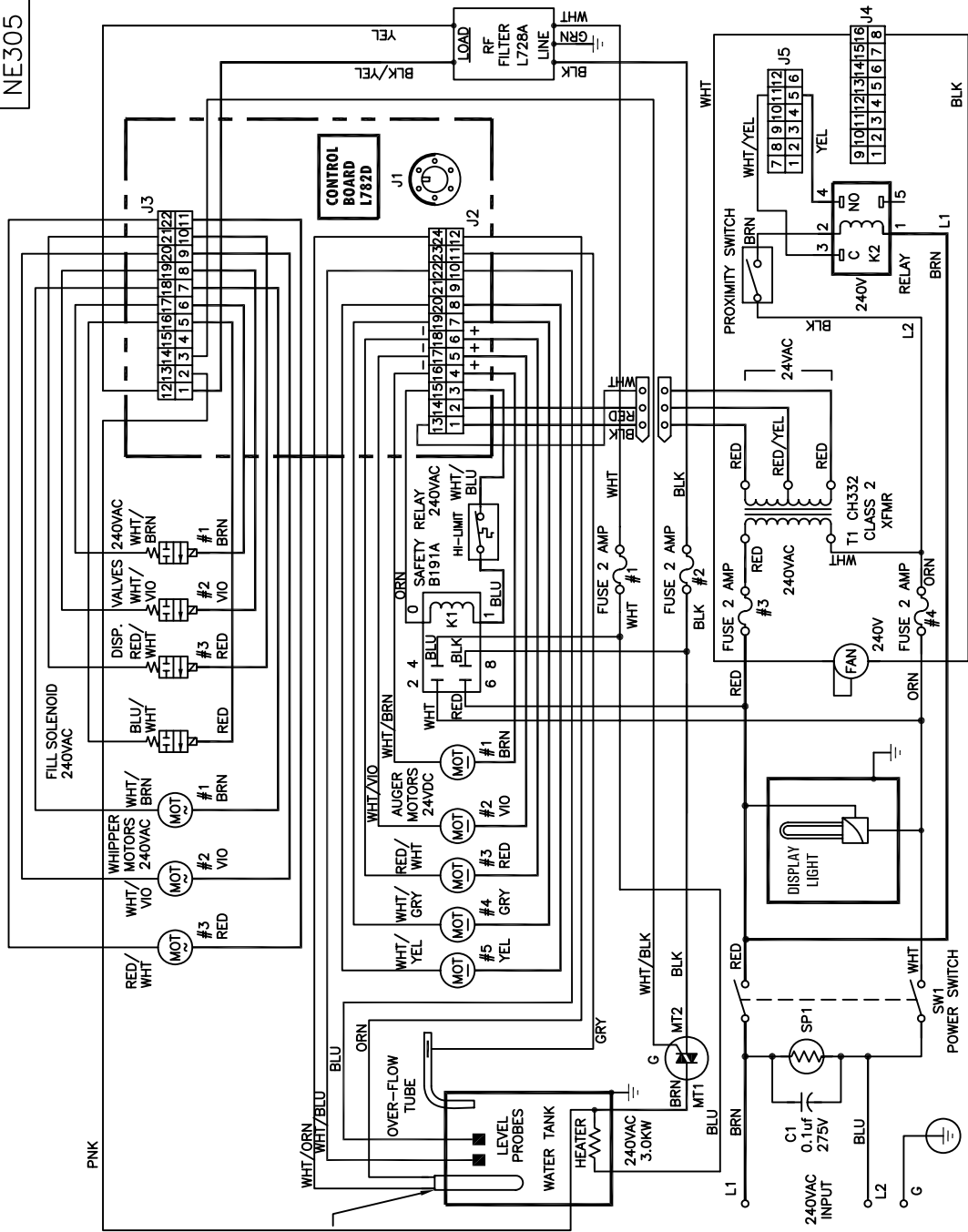

ANODE	1-1	1-2	1-3	1-4	2-1	2-2	2-3	2-4	3-1	3-2	3-3	3-4	4	5
R1														
R2	1-1	2-1	3-1	RISE										
R3	1-2	2-2	3-2	DOWN										
R4	1-3	2-3	3-3	UP										
R5	1-4	2-4	3-4	STOP	FF									

LED CIRCUIT POLARITY
 ANODE - COMMON
 CATHODE

240V

REV. BY	DATE	DESCRIPTION
±.005 ±1/64 ±1/2	APPROVED BY	MATERIAL
DO NOT SCALE THIS DRAWING	DRAWN BY	SCALE
TOLERANCES ON FINISHED DECIMAL FRACTIONAL ANGULAR MATERIAL DIMENSIONS NOT OTHERWISE SPECIFIED		
TITLE ELECTRICAL DIAGRAM-240V/3.0KW W/ 6-CHANNEL BOARD (GBSMF-IT)		
PART NO NE305		
DATE 02/04/09		
DRAWING NO NE305		
SCALE 1:1		
43-05 20 AVE. L.I.C. NY 11105		
CEGILWARE CORPORATION		
REV.		