



Cecilware®

Operator Manual

Oatmeal Dispenser



Model GB3-LPO



Table of Contents

Safety Information.....2	Maintenance7
Installation.....3	Troubleshooting Guide.....9
Operation5	Parts List.....10
Cleaning.....6	

Thank you for purchasing this quality oatmeal dispenser. For your safety and the safety of others, read all warnings and the operator manual before installing or using the product. Properly instruct all operators. Keep training records. For future reference, record serial number here:

Grindmaster-Cecilware

4003 Collins Lane, Louisville, KY 40245 USA
Phone: 502.425.4776 Toll Free: 800.695.4500
Fax: 502.425.4664
Web: gmcw.com Email: info@gmcw.com

Grindmaster-Cecilware provides the industry's BEST warranty. Visit gmcw.com for warranty terms and conditions.



**Grindmaster
Cecilware**

Safety Information

Important Safety Information



This is the safety alert symbol. It is used to alert you to potential personal injury hazards. Obey all safety messages that follow this symbol to avoid possible injury or death.

For your safety and the safety of others, read all warnings and the operator manual before installing or using the product.

DANGER: This term warns the user of imminent hazard that will result in serious injury or death.

WARNING: This term refers to a potential hazard or unsafe practice, which could result in serious injury or death.

CAUTION: This term refers to a potential hazard or unsafe practice, which could result in minor or moderate injury.

NOTICE: This term refers to information that needs special attention or must be fully understood.

WARNING

The appliance is not intended for outdoor use.

Do not clean with pressurized water or use in an area where pressurized water may be used.

Cleaning and maintenance shall be made only by properly trained persons with supervision.

CAUTION

Lifting hazard. Single person lift could cause injury. Use assistance when moving or lifting.

For safe and proper operation, the appliance has to be placed in a stable, vertical position.

The appliance is not to be used by persons with reduced physical, sensory, or mental capabilities, or lack of experience and knowledge, unless they have been given supervision or instruction. Be sure to provide supervision or instruction concerning use of the appliance in a safe way and understand the hazards involved.

Children must be supervised to ensure they do not play with the appliance.

The appliance is only to be installed in locations where it can be overseen by trained personnel.

NOTICE

To avoid damaging unit, turn on power and wait for tank to fill with water before turning on heater.

Observe machine voltage configuration. Do not apply improper voltage to machine or damage to machine will occur.

Do not use extension cord.

Installation

Description and Location of Components

Note: Refer to following illustration for description and location of COMPONENTS and CONTROLS.

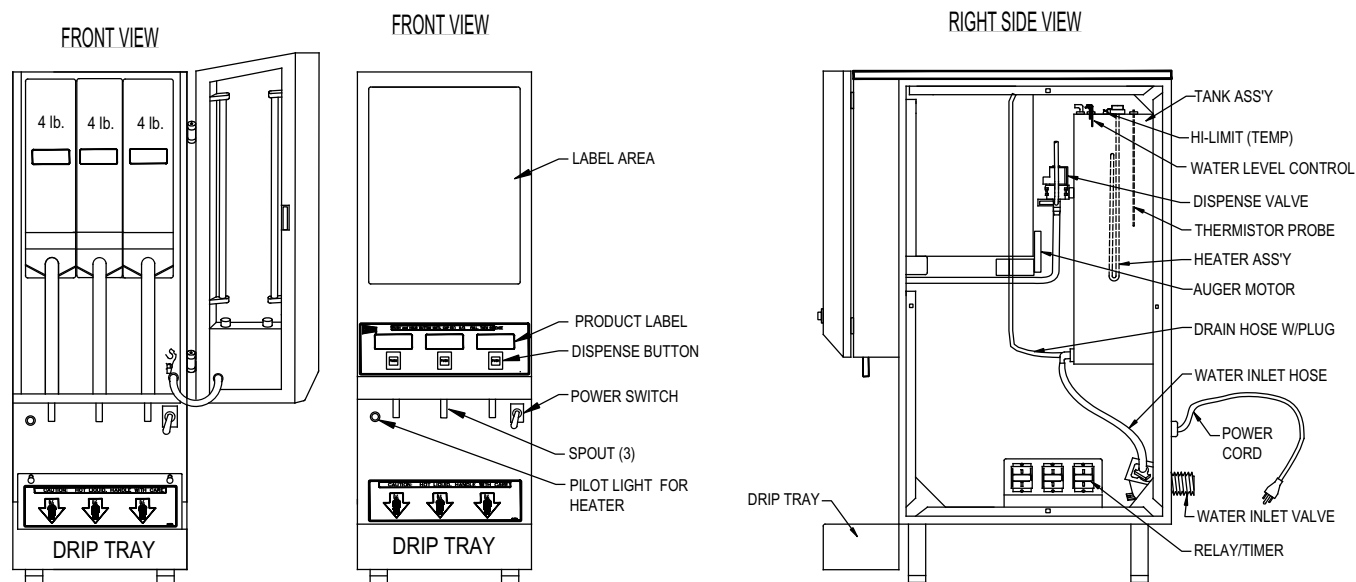

CAUTION: Lifting hazard. Single person lift could cause injury. Use assistance when moving or lifting.

Unpacking Instructions

Carefully unpack the Oatmeal Machine and inspect immediately for shipping damage. Your Oatmeal Machine was shipped in a carton designed to give it maximum protection in normal handling. It was thoroughly inspected before leaving the factory. In case of damage, contact the shipper, not Grindmaster-Cecilware.

After the machine has been unpacked and placed on a counter, pull out the stainless steel drip tray. It should contain the following:

- 1/4" Flare Water Inlet Fitting.

Water Inlet Connection:

NOTICE: This equipment is to be installed to comply with the applicable Federal, State, or local plumbing codes having jurisdiction. In addition:

1. A quick disconnect water connection or enough extra coiled tubing (at least 2x the depth of the unit) so that the machine can be moved for cleaning underneath.
2. An approved backflow prevention device, such as a double check valve to be installed between the machine and the water supply.

The GB oatmeal dispenser is equipped with a 1/4" Flare Water Inlet fitting which is located on the left side in the back of the base (when looking at the machine from the front).

Water pipe connecting and fixtures directly connected to a potable water supply shall be sized, installed, and maintained in accordance with Federal, State, and Local codes.

HIGHLY RECOMMENDED:

A WATER SHUT-OFF VALVE and A WATER FILTER, preferably a combination Charcoal/Phosphate Filter, to remove odors and inhibit lime and scale build up in the machine.

Note: In areas with extremely hard water, a water softener must be installed in order to prevent mineral deposits that could lead to malfunctioning of the equipment and in order not to void the warranty.

Installation (continued)

1. **HOPPERS:** Depress the door latch on the left side of the door and pull door open to access the hoppers.

- The hoppers hold up to 4 lbs. (1.8 kg) of Oatmeal product.
- To remove the hoppers, swing the top compartment door open and lift out the hoppers.
- To reposition the hoppers in the compartment, slide the hopper base back between the rails until the 1/4" pin at the bottom of the hopper base falls into the 1/4" positioning hole of the compartment base cover.

2. **HEATER SWITCH:** This switch is located inside the cabinet behind the right hopper; open door and remove right hopper to access it.

- Its primary function is to shut off the heating element during the initial priming, start-up operation of the machine, or whenever the tank is being drained for service.

Note: The Power Switch and Heater Switch must be ON in order for the elements to operate.

3. **POWER SWITCH:** This switch is located on the left side of the splash panel below the door.

Note: The Power and Heater Switches are independent of each other. Both switches must be OFF in order for the machine to be completely shut down.

4. **WATER LEVEL CONTROLS:** Under normal conditions and operation, the water level in the tank should not drop more than 1/2" (1.3cm) from the probe. If it does, the tank is not refilling fast enough. Check the water line and water filter; they may need cleaning or replacing.

- | | |
|-----------------------|-----------------|
| 1. Tank Control Board | Part# 349-00012 |
| 2. Water Inlet Valve | Part# L462AL |
| 3. Water Level Sensor | Part# K695QL |

Start-up Procedure

NOTICE: Make sure that the **Heater Switch**, located behind right hopper with door opened, is in the **OFF** position.

1. Connect the 1/4" dia. copper waterline to the 1/4" flare water inlet fitting of the valve.
2. Plug the power cord into a proper receptacle.
3. Activate the Power Switch (Toggle Up). The door display panel, the red power indicator light and the green dispense buttons will light up and the tank will start filling. Allow approximately 4-5 minutes for the tank to fill.
4. Activate the Heater Switch. Allow approximately 10-30 minutes for the water to reach a temperature of 190°F (88°C). The heat up time will depend on the water inlet temperature.
5. Place an 8 oz. (240ml) or larger cup under the left dispense nozzle, press and hold the left dispense switch for 6 seconds. The machine will dispense water at the rate of 1 oz. (30ml) per second. Repeat it several times to check for consistent output. Repeat same for the other dispense switches. This procedure checks that the dispense valves are not air-locked.
6. While the tank is heating, remove the hoppers, load them with products, and reposition them back in the machine. When the green ready light comes on, the tank has reached its brew temperature and the machine is ready to dispense the first cup of Oatmeal.

Filling the Hoppers

1. To remove the hoppers, swing the top compartment door open and lift out the hoppers.
2. Fill each hopper with the correct product.
3. Reposition hoppers in the hopper compartment, making sure the hoppers are properly seated.

If you need help, call Grindmaster-Cecilware Technical Service Department, (502) 425-4776 or (800) 695-4500 (USA & Canada only) 8 AM - 6 PM EST.

Prior authorization must be obtained from Grindmaster-Cecilware for all warranty claims.

Operation

Your new oatmeal dispenser is easy to operate and maintain. Before you place it in service, please have all personnel familiarize themselves with these instructions. Keep this manual in a convenient place for ready reference.

How to Operate

To dispense a cup of Oatmeal:

- Place an 8 oz. (240ml) or larger cup under selected drink dispense nozzle.
- Push and hold brew button until cup is 2/3 full, then release button.

Adjustments

Water Flow Rate Adjustment

The Dispense Valves are factory adjusted for a maximum Flow Rate of 1 to 1.3 oz./sec (30-38 ml/sec).

Note: To access the Water Dispense Valves, open door and remove Hoppers.

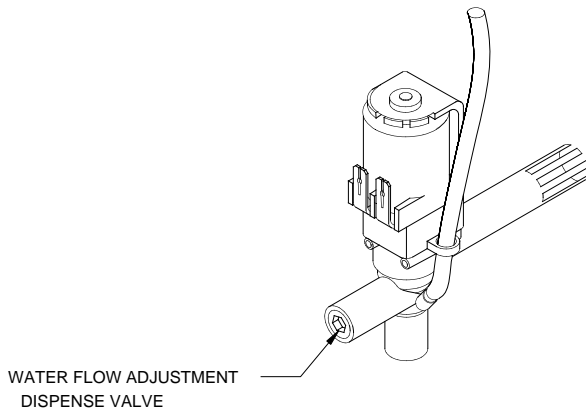

TO ADJUST WATER FLOW RATE:

1. Open door and remove hoppers. Locate Dispense Valve behind hoppers, mounted on tank.
2. Locate adjustment screw on Dispense Valve.
3. Using Allen Key or flat screwdriver rotate, 1/4 turn at a time,
CLOCKWISE to decrease water flow, or
COUNTERCLOCKWISE to increase water flow.
4. Check water flow output, after each 1/4 turn.

Temperature Adjustment (Tank Control Board Type)

1. Locate the Tank Control Board.
2. Press button under right side of display to increase temperature.
3. Press button under left side of display to decrease temperature.
4. Pressing both buttons simultaneously will reset to default 190°F (88°C).

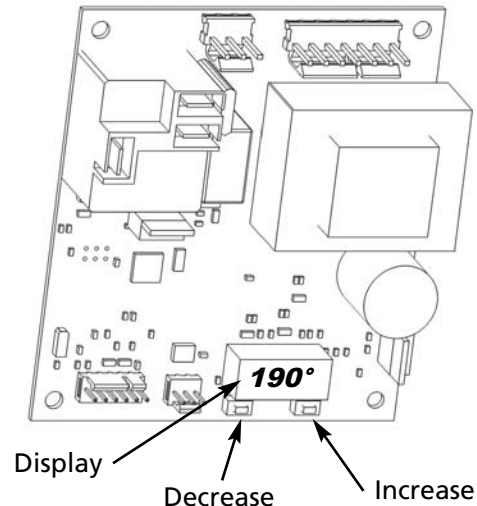

Temperature Adjustment (Thermostat Type)

1. Locate Thermostat: Remove the right side panel. Thermostat is mounted on side of tank. The GB oatmeal dispensers are factory set to deliver hot brewing water at 190°F (88°C).with the thermostat knob turned to full ON position. If adjustments should be necessary to increase or decrease the water TEMPERATURE, proceed as follows:

Note: Set the Rinse Switch to ON. This will disengage the Hopper Motors when dispensing water for Temperature measurements.

2. To INCREASE the water temperature - With the Thermostat Knob to its maximum clockwise position, remove the knob and locate the slotted adjustment screw inside the hollow thermostat shaft. Using a narrow-bladed screwdriver, engage slotted adjustment screw and turn it 1/4 turn slowly counter-clockwise.

Allow a few minutes for the temperature to reach set level. The Heater Light will go ON, indicating the heating element is activated, wait for it to go OFF, indicating that the water has reached new set temperature. Take a temperature reading and repeat if necessary.

3. To DECREASE the water temperature - simply turn the Thermostat Knob one notch counter-clockwise to the next lower dial setting.

Cleaning

NOTICE: All sanitizing agents in the food zone must comply with 21 CFR 178.1010.

Sanitize all food dispensing units periodically. All parts to be sanitized must be cleaned first. Cleaning and sanitizing frequency must follow state and local health department regulations.

Daily maintenance:

1. Remove Hoppers
 - Position a container under dispense tubes.
 - Push and hold each dispense button 10 seconds.
2. Empty drip tray, wash, rinse, and sanitize.
3. The outside of the machine can be cleaned with warm soapy water and a damp cloth.

Weekly maintenance:

Product hopper cleaning

- Rotate product guides up, remove hoppers from machine.
- Empty powder into pans.
- Pull off product guides.
- Remove agitator wheels.
- Unscrew and remove front and back auger locks.
- Remove auger.
- Wash, rinse, sanitize, and air dry all small parts.
- Wash & scrub hoppers and agitator wheel recesses with bristle brush. Rinse, sanitize, and allow to air dry.
- Reassemble all hoppers.
- Pour powder into hoppers.
- Install all hoppers into unit.

Sanitizing

1. Prepare a sanitizing solution in accordance with local health department regulations. You may also refer to the US Food and Drug Administration regulation 21 CFR 178.1010 "Sanitizing Solutions" and US Environmental Protection Agency 40 CFR 18.940 "Tolerance exemptions for active and inert ingredients for use in antimicrobial formulations (Food-contact surface sanitizing solutions)".
2. Follow the instructions provided with the sanitizing agent.
3. Let all sanitized parts drain and air dry. **DO NOT WIPE THEM DRY.**

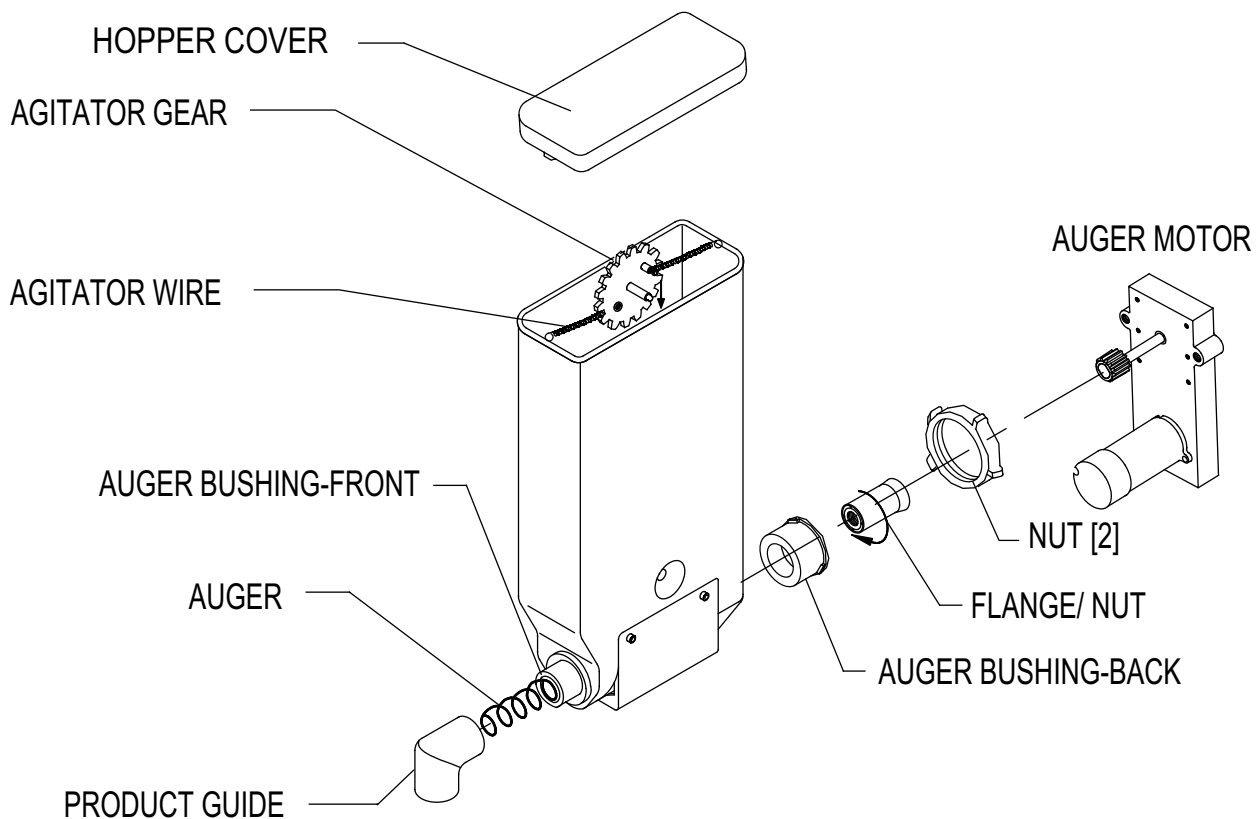

Maintenance

Lit Display Replacement

▲ WARNING Risk of electrical shock. Turn off power to unit before replacing bulb or starter.

1. Lift up the two end tabs on top of door with a pointed object or flat head screwdriver.
2. Pull the entire picture frame out. Open the two clear panels and replace picture.
3. Tuck clear plastic panel inside bracket at top.
4. Be sure to tuck clear panel under bracket before sliding frame assembly inside door.
5. The longer metal tab side goes in the front.

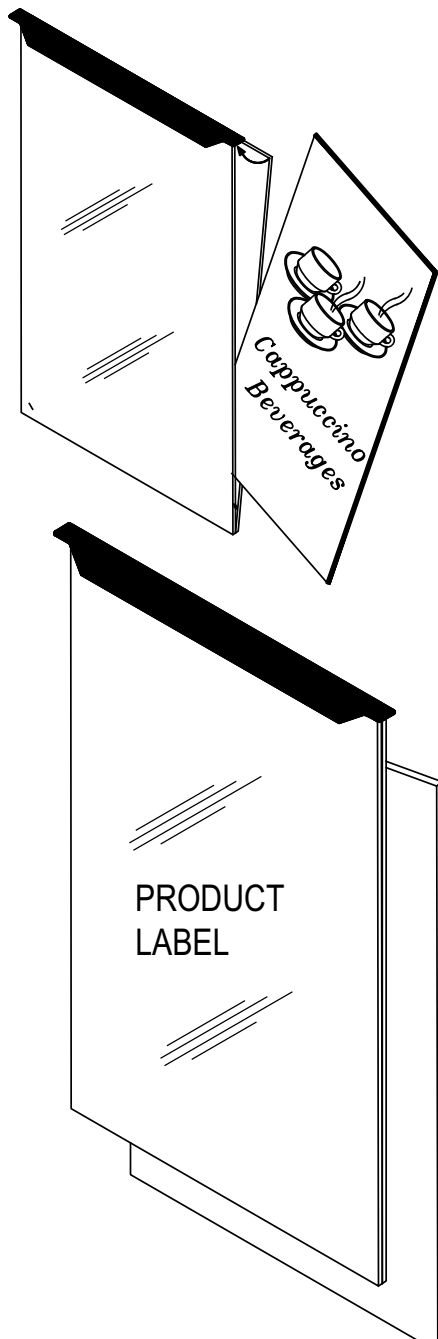

Recommended preventive maintenance

- 1) Dispense Valves
 - Check all dispense valves for lime build-up.
 - Drain the water tank to just below the level of the dispense valves.
 - Remove the valves and clean. (Take these valves apart by hand as shown).
 - Replace the assembly as needed (L467AL -120V or L676AL - 230V import).
- Replace the valve into the tank and refill tank.

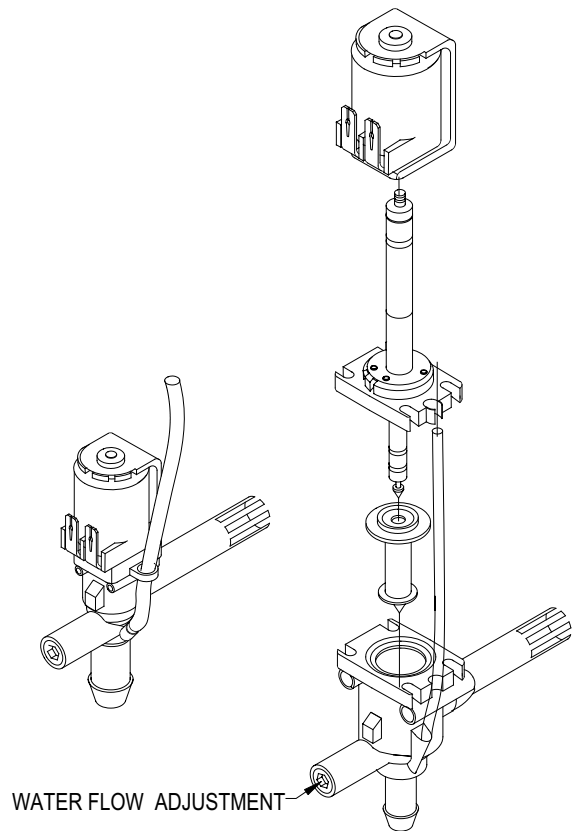

Maintenance (continued)

Component Tests

Dual Probe Test

If lack of water persists, check the probe as follows:

1. Turn on the power and water supply.
2. Check inside the tank to make sure the water is below the Probe.
3. Pull the BLUE wire and terminal OFF the Probe rod. If water still does not flow after the wire is disconnected from the Probe, the problem may be in the Tank Control Board.
4. If water starts flowing into the tank, the Probe may be grounded, due to excessive liming. Check with Ohm meter. Clean probe.

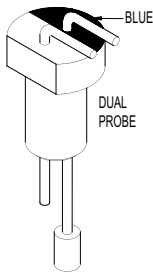

Water Inlet Valve Test

1. Turn power OFF. If the water level rises inside a partially filled tank, the Water Inlet Valve is leaking.
2. Disconnect wires from the Water Inlet Valve coil and connect a 2 wire line cord to the terminals. Plug it into a 115V outlet. If water flows in and stops when you pull it out, the Valve is working correctly. Repeat this test a few times. The problem may be in the Probe or Water Level Control Board.
3. If the water does not flow in when the cord is plugged into an electrical outlet, the Solenoid coil may be damaged, opened or the valve may have an obstruction preventing the water from flowing in. Clean or replace it.

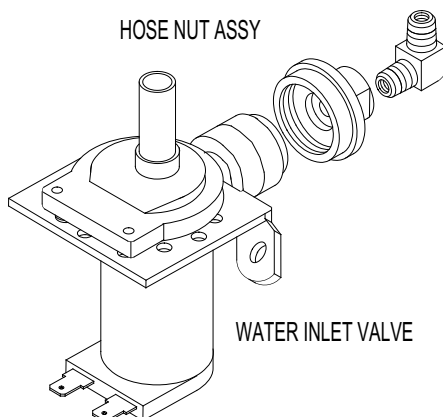

Water Level Controller Test

(For models manufactured 2015 and prior)

Check the Controller as follows:

1. Make sure there is power input to the Controller at the terminals AC1 & AC2

Your voltmeter should read 115 Volts. It should read the same at terminals AC1 & FILL when the water level is low. This is the output power to actuate the coil of the Solenoid Valve to open it. The lack of voltage at terminals AC1 & L-LEVEL or H-LEVEL indicates that the Controller is not working properly.

2. Make sure all wire connections are tight, including ground.
3. If after this, the Controller is still failing to open the Water Inlet Valve, replace it.

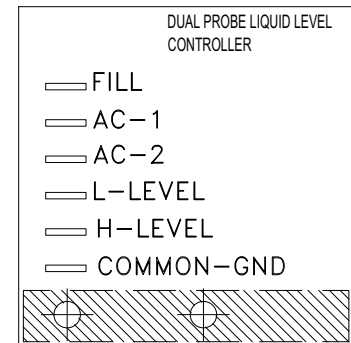
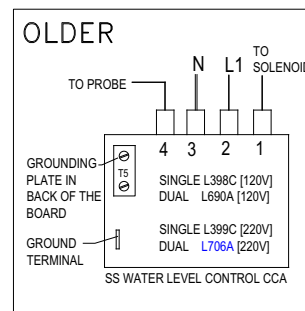

Troubleshooting Guide

Before you call for help, please read the following:

▲ WARNING: To reduce the risk of electrical shock, unplug the dispenser power cord before repairing or replacing any internal components of the unit. Before any attempt to replace a component, be sure to check all electrical connections for proper contact.

Problem	Possible Cause	Solution
Light Display not lit. No power.	Dispensing unit unplugged. No power from Terminal Block. Defective Bulb. Defective Ballast. Loose Bulb in socket.	Reconnect dispensing unit. Check the Terminal Block for loose wire. Replace Bulb. Replace Ballast. Make sure bulb is seated properly in socket.
No water when Rinse Switch is ON.	Water supply OFF. Clogged inlet screen (Water Inlet Valve). Inoperative Water Inlet Valve. Loose electrical connection.	Turn water ON. Disconnect water line and clean inlet screen. Check connection, if needed replace Valve. Check all electrical connections.
No product when Dispense Button is pressed.	No product in Hopper. Auger not working. Damaged, loose, or missing Agitator Gear. Inoperative Auger Motor or Relay. Hopper outlet clogged. Faulty Coupling.	Add product. Engage Hopper/Nut to Motor Gear. (See pg 6). Replace Agitator Gear (See pg 6). Check connections of Motor, Relay, and/or Switch; if needed replace components. Clean Hopper and check Cartridge Heater. Replace damaged Coupling components.
Water does not shut off. Water keeps dispensing.	Leaking Water Inlet Valve. Inoperative Dispense Switch. Inoperative Rinse Switch. Clogged/stuck Water Dispense Valve.	Clean/check fittings of Water Inlet Valve. Replace Water Inlet Valve if needed. See Water Inlet Valve Test. Check Switch connections. Replace Dispense Switch if needed. Check Rinse Switch connections. Replace Rinse Switch if inoperative. Clean or unclog Water Dispense Valve. Replace Dispense Valve if inoperative.
No water is going into tank at all.	Water Inlet Valve malfunction. Water Level Sensor/ Probe malfunction. Solid State Level Control Board.	Check Solenoid. Replace if necessary. See Water Inlet Valve Test. Check Probe. Replace if necessary. See Probe Test. Check Water Level Controls. Replace if necessary. See Water Level Controller Test.
Water will not stop flowing into water tank.	Water Level Probe malfunction. Solenoid (Water Inlet Valve) malfunction. Solid State Water Level Control malfunction.	Check Probe. Replace if necessary. See Probe Test. Check Solenoid. Replace if necessary. See Water Inlet Valve Test. Check the Water Level Controls. Replace if necessary. See Water Level Controller Test.
Water is not heating up in the water tank.	Heater Switch is OFF. Thermostat is OFF. (Only models with separate Thermostat) Loose connection on Thermostat. Hi-Limit Temperature Switch is defective. Heater is burned out or defective.	Turn Heater Switch ON. Turn Thermostat ON. Turn Knob Clockwise. Make sure all wires and terminals on Thermostat are tight. Replace the Hi-limit. Replace the Heater.

Troubleshooting Guide (continued)

If you still need help, call Grindmaster-Cecilware Technical Service Department, (502) 425-4776 or (800) 695-4500 (USA & Canada only) (Monday through Friday 8 AM - 6 PM EST). Please have the model and serial number ready so that accurate information can be given.

Prior authorization must be obtained from Grindmaster-Cecilware for all warranty claims.

Grindmaster-Cecilware provides the industry's BEST warranty. Visit our website at GMCW.com for warranty terms and conditions.

Parts List

Hopper Parts

HOPPER ASS'Y [CD152L](#), 4 LB, 11.5"H x 3"W, W/WIRE AUGER [CD101L](#)

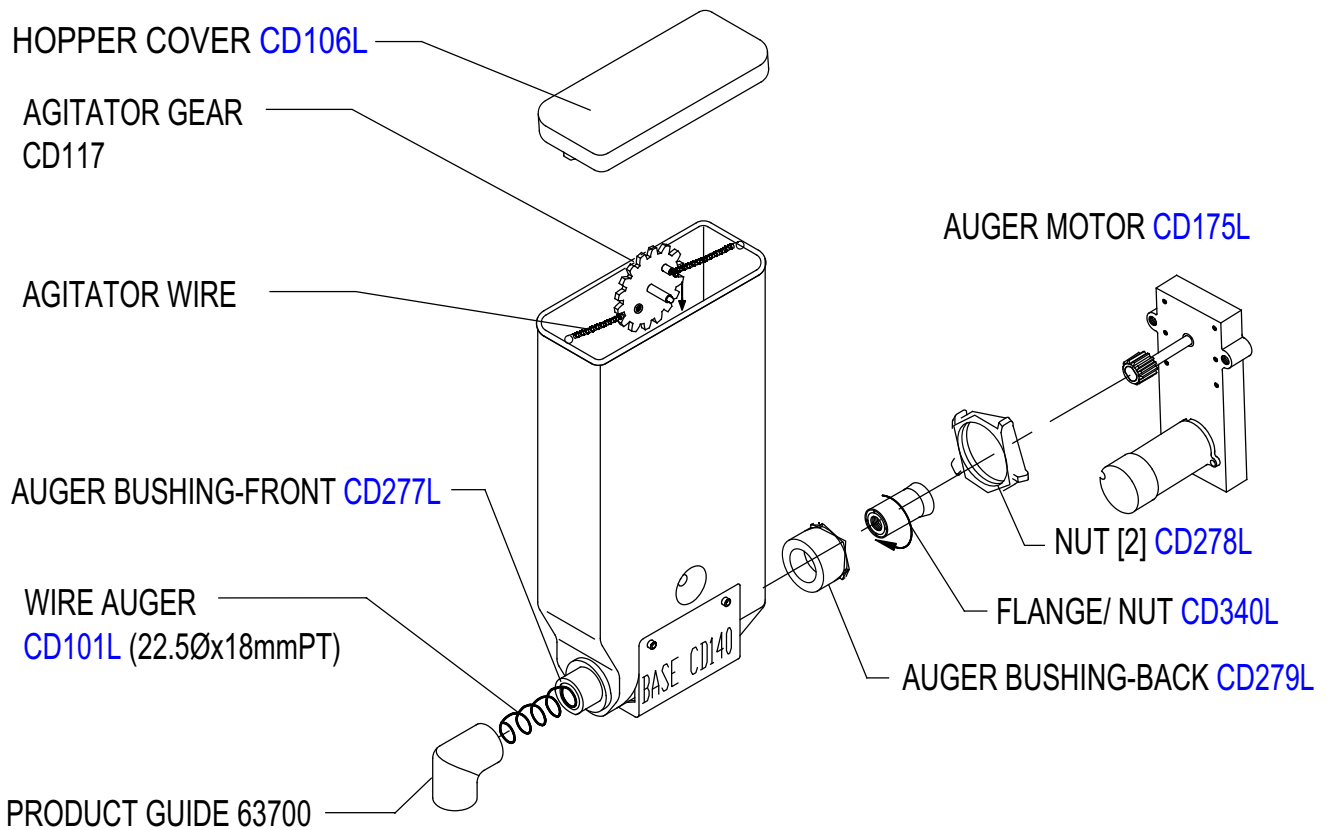

Parts Diagram and List (continued)

Tank Parts

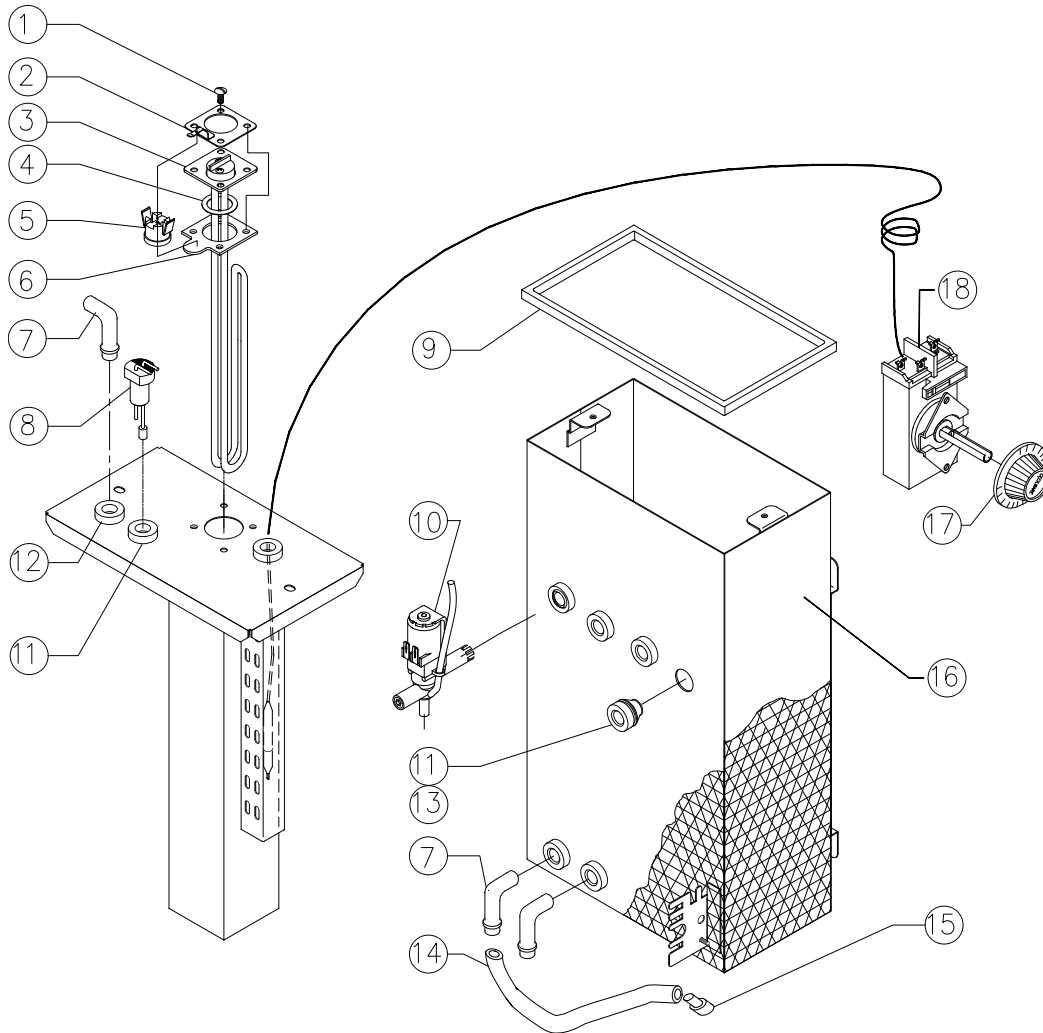

2.8 GALLON TANK

ITEM	DESCRIPTION	PART NO	QTY
1	SCREW, 1/4-20x5/8, SST, TRUSS HD, SLTD	P465A	4
2	HEATSINK SHIM ASSEMBLY	K667Q	1
3	HEATER, 120V 1700W	G267A	1
4	O-RING 1 1/4 ID x 1 5/8 OD	M773A	1
5	HI-LIMIT 200° CUTOUT, 5/8" TRIG, #T500	L656A	1
6	HEATSINK, 1/8" ALUMINUM #1100	K661A	1
7	ELBOW 90°	K525A	3
8	LEVEL SENSOR, DUAL PROBE	K695Q	1
9	SILICONE BUTT SPLICED GASKET	M601A	1
10	DISPENSE VALVE	L467A	3
11	SILICONE SEAL (12mm)	M461A	8
12	SILICONE SEAL (15mm)	M462A	1
13	SILICONE PLUG	M494A	1
14	DRAIN HOSE	M483A	1
15	DRAIN PLUG	M391A	1
16	TANK WELDMENT 2.8 GAL	SC36Q	1
17	THERMOSTAT KNOB*	M008A	1
18	THERMOSTAT*	L532A	1

*NEW IN 2015

REPLACE THERMOSTAT AND THERMOSTAT KNOB WITH THERMISTOR PROBE
PART #61128

Parts Diagram and List (continued)

Unit Parts

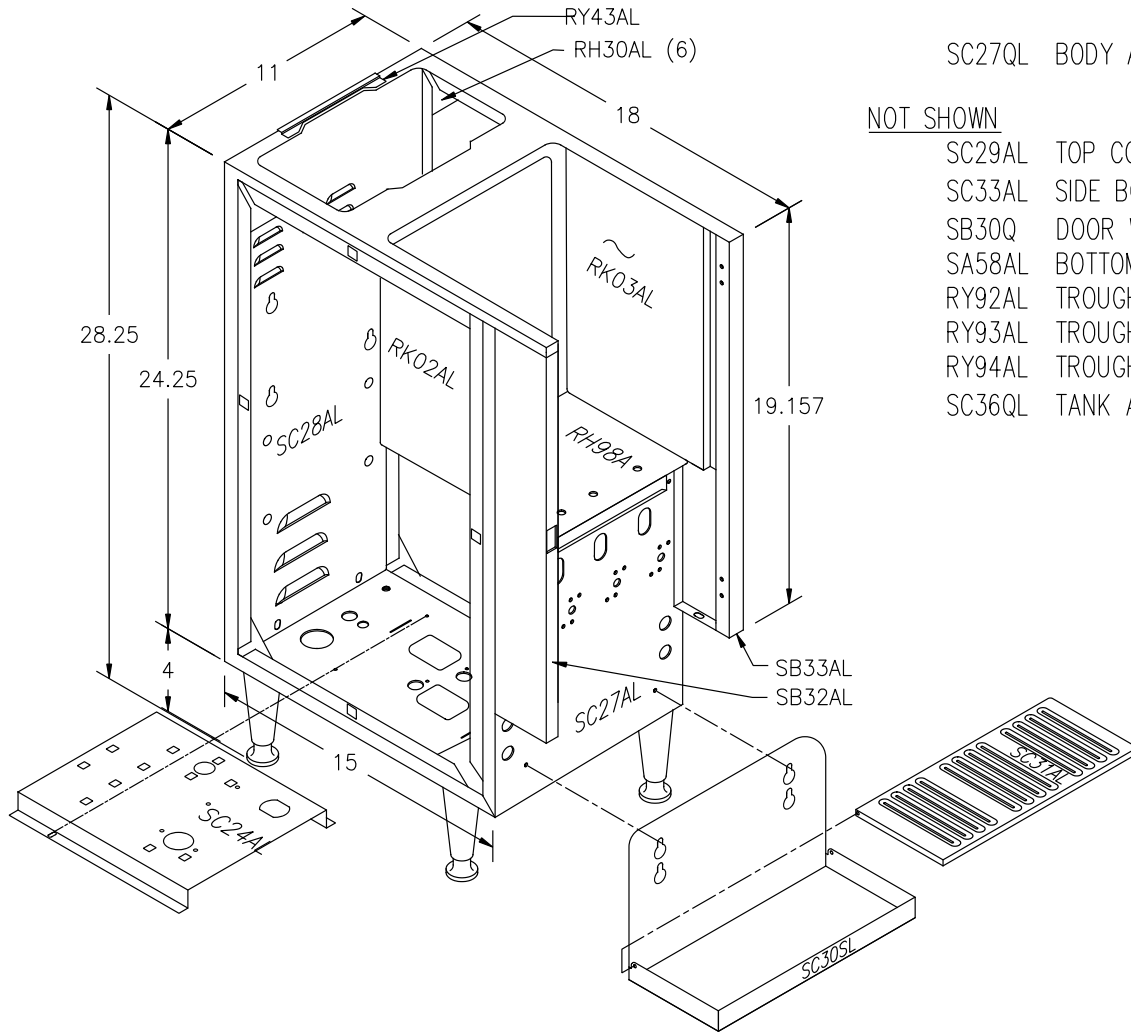

SC27QL BODY AND TANK ASS'Y

NOT SHOWN

- SC29AL TOP COVER
- SC33AL SIDE BODY PANELS [2]
- SB30Q DOOR WELDMENT ASS'Y
- SA58AL BOTTOM FACIA
- RY92AL TROUGH
- RY93AL TROUGH DRAWER
- RY94AL TROUGH FRONT PLATE
- SC36QL TANK ASS'Y

Grindmaster-Cecilware

4003 Collins Lane, Louisville, KY 40245 USA
 Phone: 502.425.4776 Toll Free: 800.695.4500
 Fax: 502.425.4664
 Web: gmcw.com Email: info@gmcw.com

©2016 Grindmaster-Cecilware
 Printed in USA



0516 Form # CW-325-01
 Part # 390-00061