

ICED TEA MODULAR BREWER AND DISPENSER SYSTEM

FTC 3, 5, 10 GALLON



CONTENTS:

- Specification
- Installation & Start-Up
- Tea Strength Adjustment
- Cleaning and Sanitizing
- Trouble Shooting Guide
- Wiring Diagram
- Brew Volume Adjustment Diagram
- Parts List

MODEL NUMBERS:

Brewer	FTC-3	FTC-3.5	FTC-5	FTC-10
Dispenser only	S3C	S3.5C	S5C	S10C
Dispenser w/Round Stand	SU-3P	SU-3P	SU-5P	SU-10P
Capacity	3 Gallon	3.5 Gallon	5 Gallon	10 Gallon

Cecilware sells value... Worldwide

43-05 20th Avenue, Long Island City, NY 11105

● 718-932-1414
FAX. 718-932-7860



FTC-Series Fresh Brew Tea Brewers & Dispensers

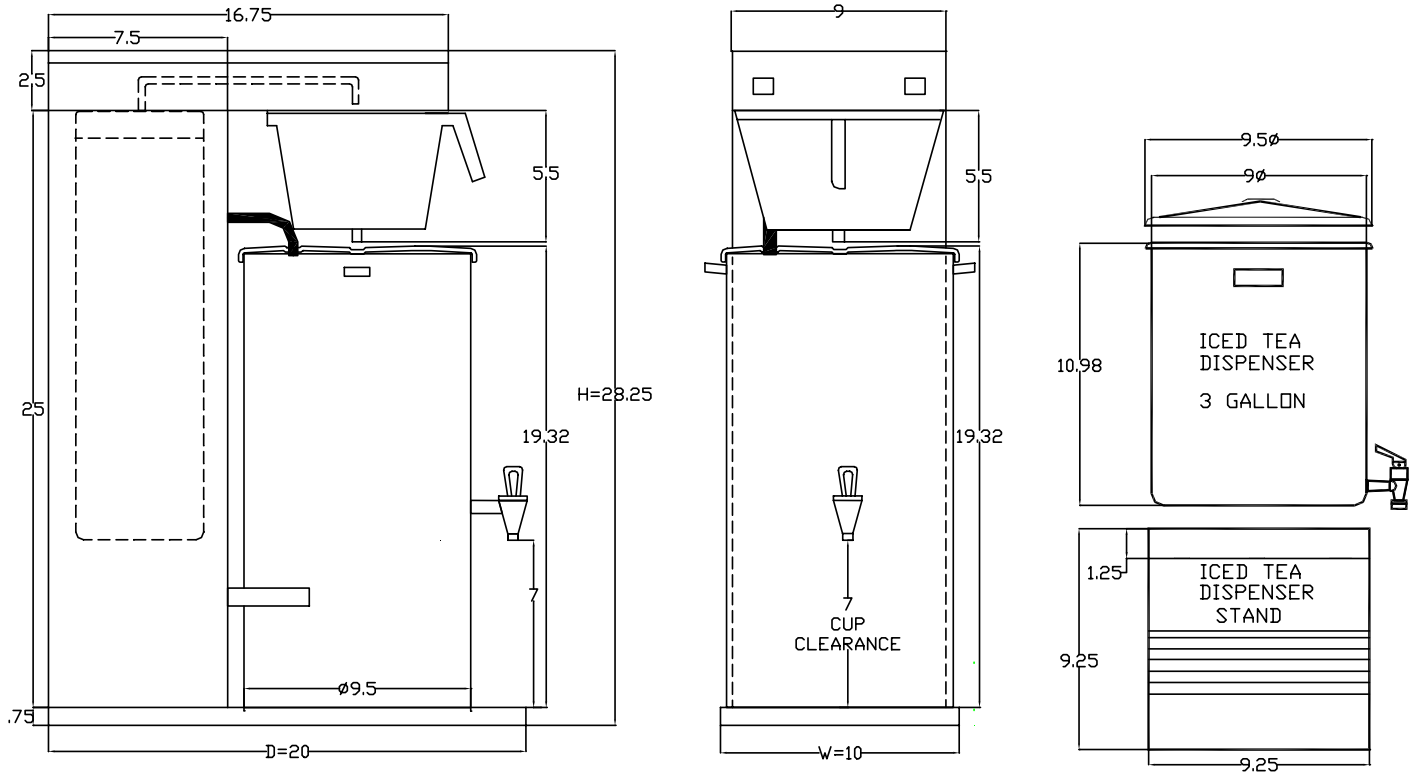

DIMENSIONAL SPECIFICATIONS

MODEL NO.	DESCRIPTION	WIDTH (W)	DEPTH (D)	HEIGHT (H)
FTC-3 SHOWN ABOVE	3 GAL. TEA BREWER	10"	20"	28 3/4"
S3C SHOWN ABOVE	3 GAL ICED TEA DISPENSER	9 1/2" DIA.	-	18 3/4" [19 5/8 W/ BREW COVER]
SU-3P SHOWN ABOVE	3 GAL ICED TEA DISPENSER WITH ROUND STAND	9 1/2" DIA.	-	18 1/4" [18 7/8 W/ BREW COVER]
FTC-5	5 GAL. TEA BREWER	10 1/8"	21 1/2"	34 1/2"
S5C	5 GAL TEA DISPENSER	9 1/2" DIA.	-	24 3/4" [25 1/4 W/ BREW COVER]
S5W	5 GAL TEA DISPENSER- WIDE	12 1/4" DIA.	-	18 3/4" [19 W/ BREW COVER]
SU-5P	5 GAL TEA DISPENSER WITH ROUND STAND	12 3/4" DIA.	-	18" [18 1/4 W/ BREW COVER]
FTC-10	10 GAL TEA BREWER	14 1/2"	22"	35"
S10C	10 GAL TEA DISPENSER	14" DIA.	-	24 3/4" [25 1/4 W/ BREW COVER]

ELECTRICAL SPECIFICATIONS

MODEL NO.	VOLTS	WATTS	AMPS	NEMA LINE CORD
FTC-3	120	1700	14.2	5-15P
FTC-5/10	120	1700	14.2	5-15P
FTC-3	240	2,400	10.0	6-15P
FTC-5	240	2,400	10.0	6-15P
FTC-10	240	3,500	14.6	6-20P

INSTALLATION AND OPERATION INSTRUCTIONS

UNPACKING AND ASSEMBLY:

The machine is shipped with 1 funnel ass'y and a water inlet fitting.

ACCESSORIES USED WITH THE MACHINE:

Sanitary Style Iced Tea Dispenser.

WATER INLET CONNECTION:

The National Sanitation Foundation (NSF) requires the following for an NSF approved hook-up.

This equipment is to be installed to comply with the applicable federal, state, or local plumbing codes having jurisdiction.

In addition:

1. A quick disconnect water connection or enough extra coiled tubing (at least 2x the depth of the unit) so that the machine can be moved for cleaning underneath.
2. An approved back flow prevention device, such as a double check valve to be installed between the machine and the water supply.

The **FTC-3, FTC-5, FTC-10** are equipped with 1/4 flare water inlet fitting, located in the back of the unit.

Connect the 1/4" dia. Copper waterline to the 1/4" flare water inlet fitting of the valve.

HIGHLY RECOMMENDED: A water shut-off valve and a water filter, preferably a combination charcoal/ phosphate filter, to remove odors and inhibit lime and scale build up in the machine.

Note: In areas with extremely hard water, a water softener must be installed in order to prevent a malfunctioning of the equipment and in order not to void the warranty.

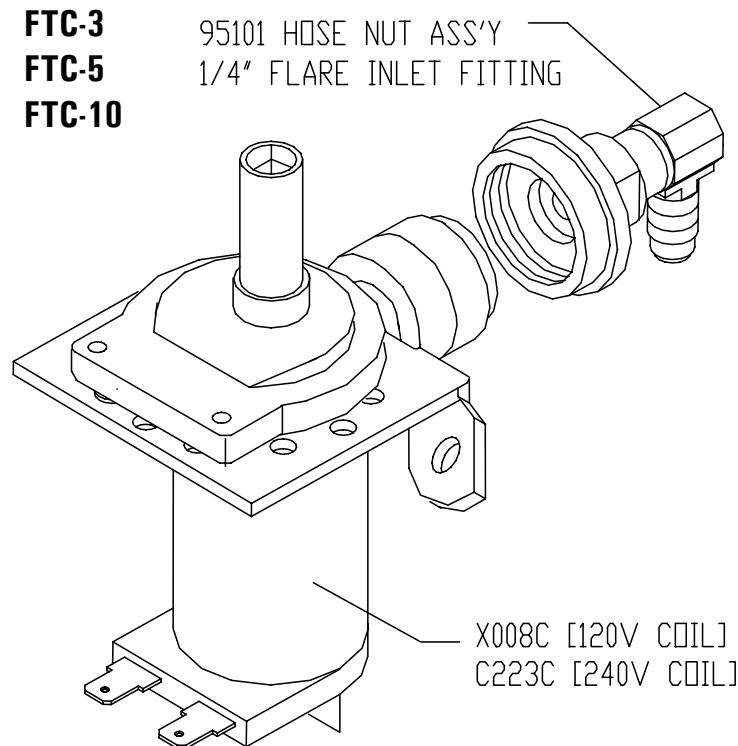

WATER INLET VALVE # 80235

INITIAL PRIMING - FILLING OF TANK

NOTE: DO NOT PLUG BREWER INTO POWER OUTLET UNTIL YOU ARE SURE THE HEATER SWITCH IS IN THE OFF POSITION. Switch must remain in the OFF position until the PRIMING OPERATION has been completed. This procedure protects the Element from accidental burnout.

LOCATION OF TOGGLE HEATER SWITCH:

FTC-3, FTC-5, AND FTC-5L, FTC-10; SEE BACK OF TOP CONTROL BOX.

PRIMING PROCEDURE:

- Turn on the water supply and check for leaks at connections.
- Plug power cord into a 15 amp 120 volt grounded outlet.
- Remove sample filter pack from funnel and insert funnel back into machine.
- Position carrier under funnel making sure holes in cover line up with funnel and dilution tube.
- Push RED POWER SWITCH to ON position.
- Push GREEN BREW SWITCH and release. Water should start to flow from the DILUTION TUBE into the CARRIER. No water will flow from the funnel until halfway through the cycle (about 5 minutes).

PRIMING AND TESTING PROCEDURE BEFORE UNIT HAS REACHED BREWING TEMPERATURE:

- Shut off heater switch [toggle down]. This will bypass the lockout circuit.
- Activate the red power switch.
- Activate the green brew switch for one complete cycle.
- At the end of one brew cycle, discard water from dispenser and reposition under brew funnel.

TOTAL VOLUME OUTPUT CHECK:

- Place empty CARRIER less Cover under funnel.
- Activate GREEN BREW SWITCH.
- At the end of brew cycle (about 10 minutes) water level inside Carrier should be within 2 inches from the top.
- If necessary adjust TIMER. See TIMER ADJUSTMENTS.

TURNING ON HEATING ELEMENTS:

- Flip the Toggle Switch in the back of the brewer to the UP or ON position.
- Allow 20 minutes to reach brewing temperature (195 F).
- When the READY LIGHT comes on, the brewer is ready to brew.

BREWING INSTRUCTIONS:

Place empty CARRIER under Funnel. Make sure openings in cover line up properly with funnel outlet and dilution tube.

TEA BAGS - Place correct number of tea bag(s) directly into brew funnel.

Replace funnel into brew head of unit and push brew switch when GREEN READY LIGHT comes on.

GROUND TEA LEAVES - Place paper filter into brew funnel and add proper amount of fresh ground tea leaves into filter.

Replace funnel into brew head of unit and push brew switch when GREEN READY LIGHT comes on. See chart below for the recommended ounces of ground tea leaves.

TEA BREWING RECOMMENDED MEASUREMENTS

MODEL #	SIZE & QUANTITY OF TEA BAGS	GROUND TEA LEAVES - OUNCE
FTC-3	(1) 3 Gallon Bag	3-4 Ounces
FTC-5	(2) 3 Gallon Bags or (6) 1 Gallon Bags	4-6 Ounces
FTC-10	(3) 3 Gallon Bags or (9) 1 Gallon Bags	9 Ounces

Allow approximately 10 minutes for a complete brew cycle. DO NOT remove brew funnel until it has stopped dripping.

Serve Fresh Brewed Tea from dispensing faucet into tea glass over ice.

ADJUSTMENTS TO BE PERFORMED BY QUALIFIED SERVICE PERSONNEL ONLY.

CAUTION: BREWERS SHOULD BE UNPLUGGED FROM ELECTRICAL OUTLETS

BREW VOLUME and STRENGTH ADJUSTMENTS:

The water flow rate coming from the hot water tank is constant/fixed at 0.75 gal/min.

Increasing or decreasing the amount of hot water dispensed from tank can also be used to adjust the strength of the tea.

Longer water flows – More water – Weaker tea; Less water flows – Less water – Stronger tea.

TIMER ADJUSTMENTS FTC-3, FTC-5:

- Remove top cover and Locate Timer on the left side.
- To brew MORE tea: Turn timer knob one increment CLOCKWISE.
To brew LESS tea: Turn the timer knob one increment COUNTERCLOCKWISE.
- Go through a COMPLETE brew cycle. Repeat if necessary.

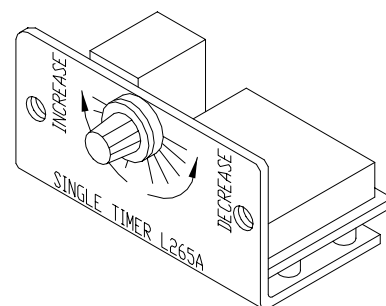

"TEACH ME" TIMER L576A ADJUSTMENTS – FTC 10:

This timer can be programmed from the brew button to dispense different volume of hot water .

<u>PRIMING:</u>	<ol style="list-style-type: none">1. MAKE SURE HEATER SWITCH IS OFF.2. PUSH & HOLD DOWN BREW BUTTON WHILE SWITCHING POWER ON.3. RELEASE BREW BUTTON.4. PUSH BREW BUTTON AGAIN & WAIT FOR WATER TO START FLOWING OUT OF SPRAY HEAD.
<u>PUT TIMER INTO PROGRAM MODE:</u>	<ol style="list-style-type: none">1. START WITH POWER OFF.2. WHILE HOLDING DOWN BREW BUTTON, TURN POWER ON.3. RELEASE DISPENSE BUTTON.
<u>PROGRAM THE BREW BUTTON:</u>	<ol style="list-style-type: none">4. PUSH BREW BUTTON TO START TIME [product begins dispensing].5. PUSH BREW BUTTON AGAIN TO STOP TIME [about 2" from top of dispenser for 10 gal.] [product stops dispensing] .6. BREW BUTTON CAN BE JOGGED TO TOP OFF CONTAINER.
<u>PUT TIMER INTO RUN MODE:</u>	<ol style="list-style-type: none">7. TURN POWER OFF AND ON AGAIN [this locks in total dispense time].
NORMAL OPERATION: TURN POWER ON, TURN HEATER SWITCH ON, WAIT 20 MINUTES UNTIL READY LIGHT COMES ON. UNIT IS READY TO BREW.	

STANDARD - BREW VOLUME ADJUSTMENT DIAGRAM FTC3, FTC-5, FTC-10

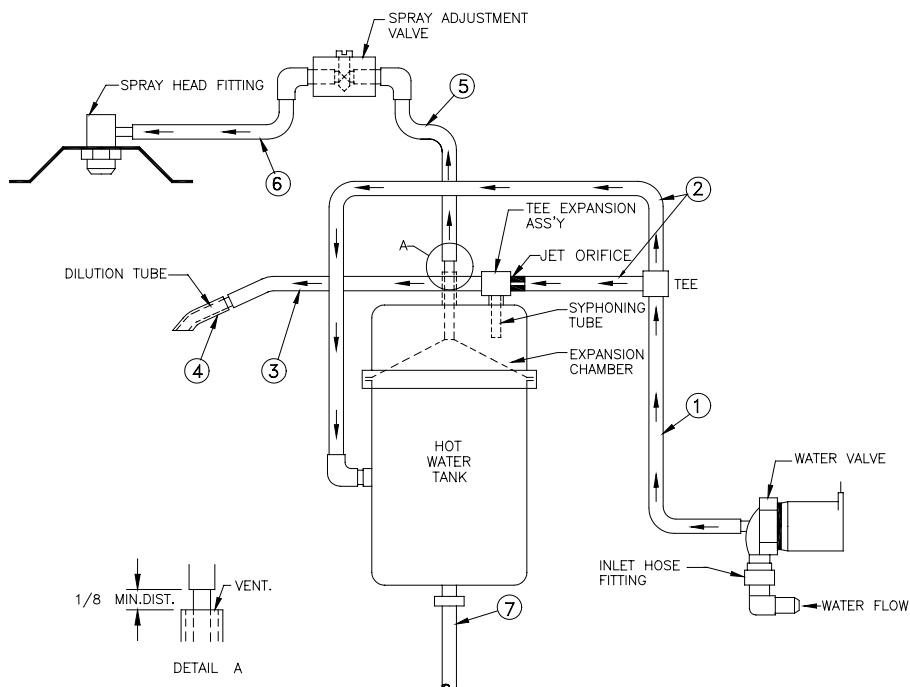
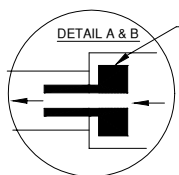

FIG.	DESCRIPTION	PART NO.
1	3/8 O.D. x 21 1/2 L.	77279
2	3/8 O.D. x 7"	77426
3	3/8 O.D. x 9 1/4 L.	77246
4	3/8 O.D. x 4 1/2 L.	77277
5	3/8 O.D. x 10 1/2 L.	77243
6	3/8 O.D. x 10 1/2 L.	77243

FIG.	DESCRIPTION	PART NO.
1	1/2 O.D. x 16" L.	M283C
2	1/2 O.D. x 10" L.	M281C
3	1/2 O.D. x 4" L.	M286C
4	1/2 O.D. x 5 1/2" L.	M274C
5	3/8 O.D. x 11" L.	M284C
6	3/8 O.D. x 9 1/4 "L.	77246
7	3/8 O.D. x 10 1/2"L.	77243



FLOW CONTROLLER - HOT SIDE [25%] - BLACK M647A
 FLOW CONTROLLER - COLD SIDE [75%] - WHITE M279A

THE FLOW CONTROLLER ACTS AS A FLOW REGULATOR IN PLACE OF AN ADJUSTMENT VALVE. IT REGULATES THE VOLUME FLOW TO GIVE AN OUTPUT RATIO OF 75% COLD WATER TO 25% HOT TEA CONCENTRATION.

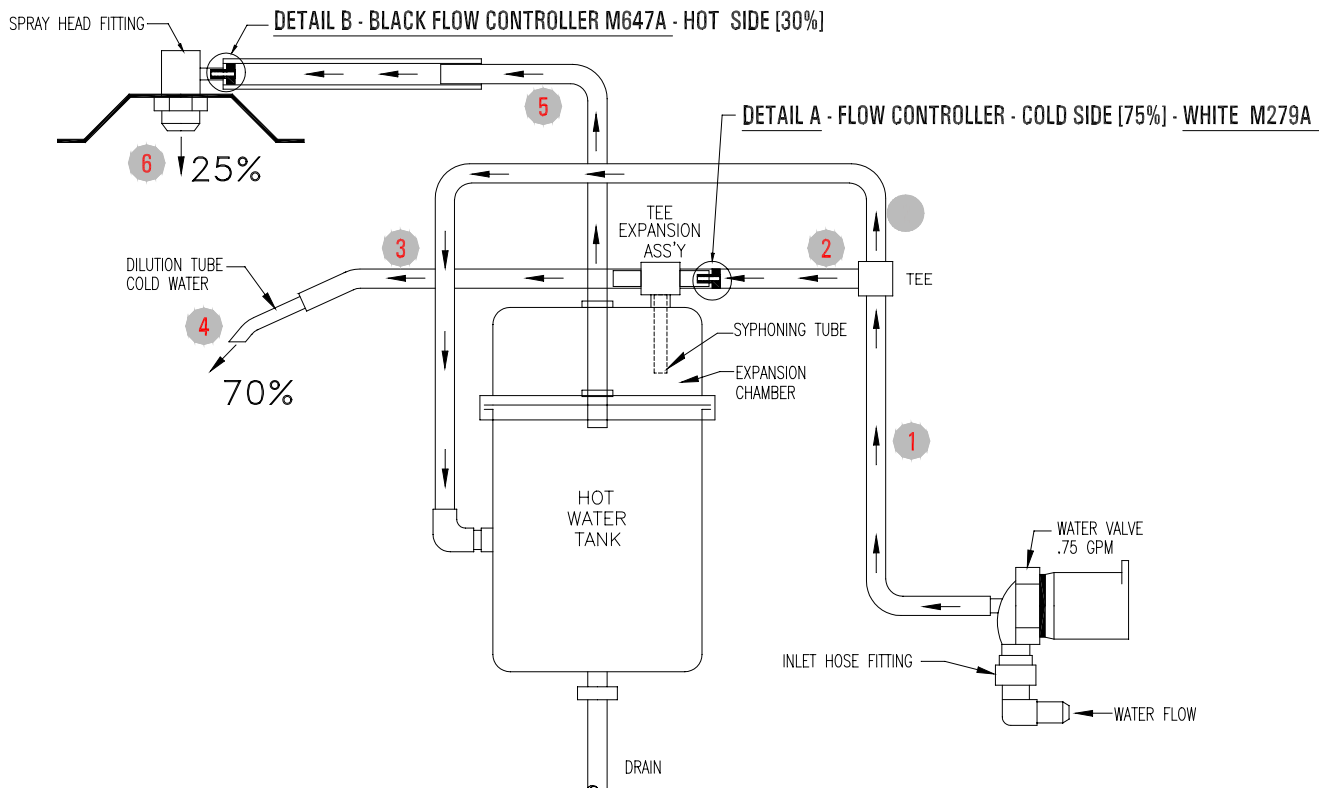

FLOW CONTROLLER

FLOW CONTROLLER - HOT SIDE - BLACK M647A

THE FLOW CONTROLLER ACTS AS A FLOW REGULATOR IN PLACE OF AN ADJUSTMENT VALVE. IT REGULATES THE VOLUME FLOW TO GIVE AN OUTPUT RATIO OF 70% COLD WATER TO 30% HOT TEA CONCENTRATION.

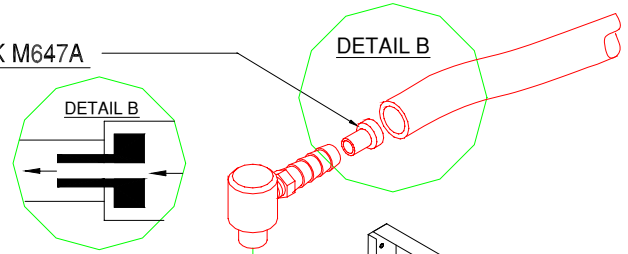

FUNNEL ASSEMBLY

FTC-3/5 FUNNEL ASS'Y #V236A

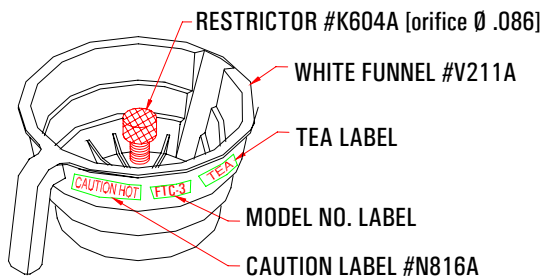

FTC-10 FUNNEL ASS'Y #Q183Q

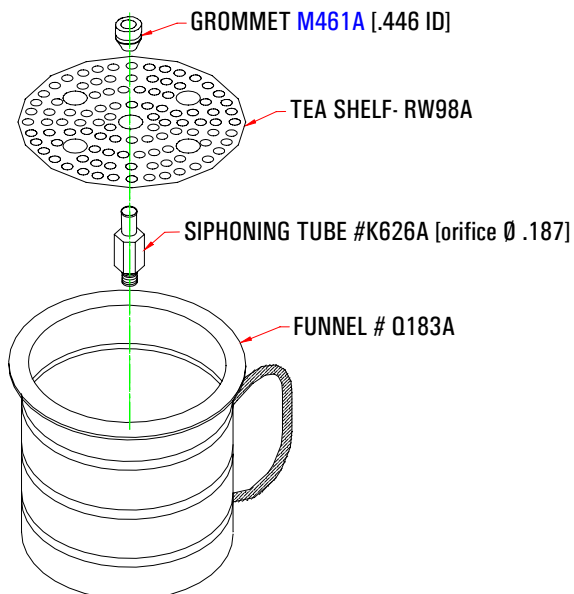

BREW FUNNEL ASS'Y
FOR FTC-3, FTC-5
ICE TEA BREWERS

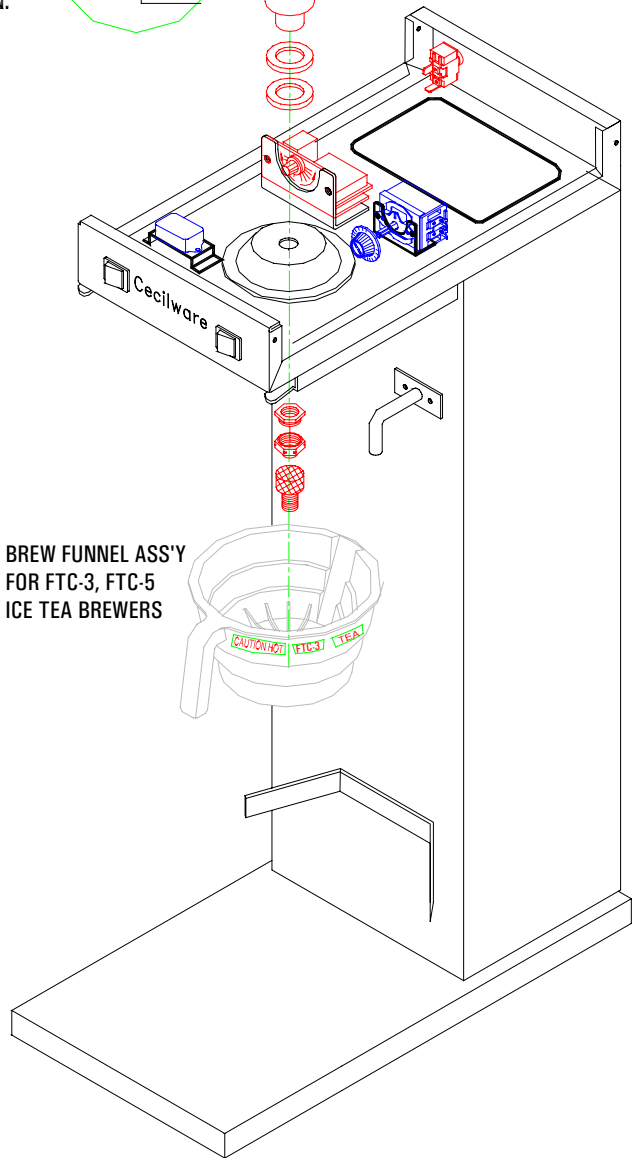

THERMOSTAT ADJUSTMENT

Two types of Thermostats are used on FTC Brewers:

Type A - Surface mounted thermostat with slotted adjustment stem. Should not be adjusted past 195° F.

Type B - Capillary bulb thermostat with adjustment knob. Should not be adjusted past 203° F.

If field adjustments are needed, INCREASE or DECREASE temperature by GRADUALLY rotating the adjustment stem or knob CLOCKWISE OR COUNTER-CLOCKWISE.

Type B - Thermostats can be fine-tuned as follows:

- Make sure ADJUSTMENT KNOB is turned clockwise to its maximum position.
- Pull off ADJUSTMENT KNOB and locate small adjustment screw.
Turn 1/4 turn COUNTER-CLOCKWISE TO INCREASE temperature and CLOCKWISE TO DECREASE temperature.
- When GREEN BREW LIGHT comes on, take all temperature readings at the spray head with the spray head removed.

TYPE A - 59016
SURFACE MOUNT THERMOSTAT
OLDER UNITS

TYPE B - L532A
CAPILLARY- BULB THERMOSTAT
NEW UNITS 7/24/98

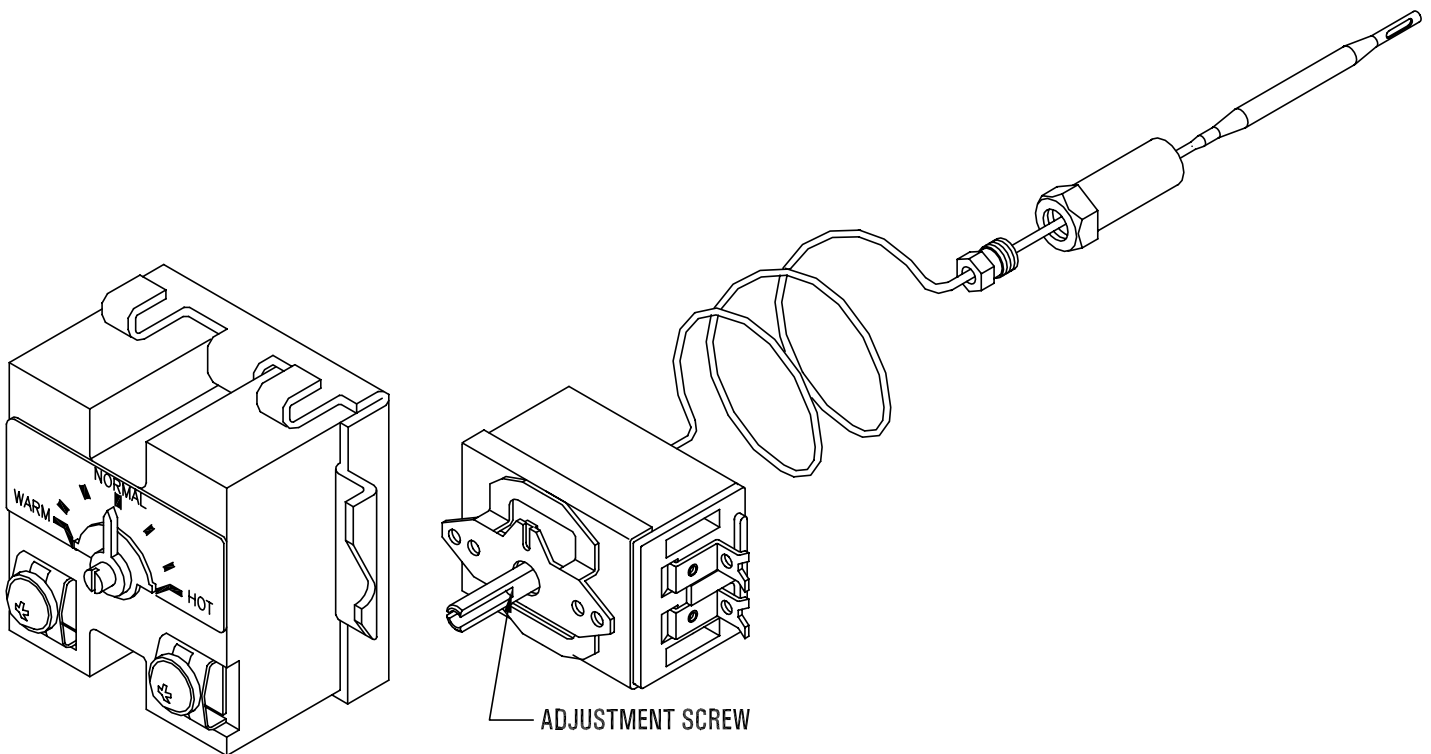

CLEANING AND SANITIZING INSTRUCTIONS

A. MACHINE: Wipe exterior of dMachine with a soft damp cloth.

B. DISPENSER [ICED TEA CONTAINER]: Wash tea carrier with mild soap and warm water.
Rinse thoroughly and replace on stand.

PROPER CLEANING AND SANITIZING OF THE FAUCET ON YOUR TEA DISPENSER IS NECESSARY TO DELIVER GREAT TASTING FRESH BREWED ICED TEA. TOMLINSON SPB/SPBH FAUCET DO NOT REQUIRE TOOLS FOR CLEANING AND SANITIZING.

TO PREVENT BACTERIAL GROWTH FOLLOW STEP BY STEP SEQUENCE AND REFER TO THE DIAGRAM BELOW.

IMPORTANT: TO PREVENT BACTERIAL GROWTH AND PROTECT TEA FLAVOR, CLEAN AND SANITIZE TEA BREWING AND STORAGE EQUIPMENT AT LEAST **ONCE A DAY** AS FOLLOWS:

CONTAINER:

1. Inside Surface - Using hot water and dishwashing detergent, scrub interior of container with a bristle brush, including corners and bottom, to remove residues, then rinse thoroughly.
2. Outside Surface - Wash surface with sponge using hot water and dishwashing detergent.

FAUCET:

1. Remove the entire upper assembly of faucet by unscrewing the bonnet.
2. Pull seat cup off from inside the upper assembly of faucet. Inspect for war or hardening. Replace if necessary.

Clean all parts, including faucet body in hot soapy water.

Sanitize with chlorine [50 ppm], iodine [14 ppm] or quaternary ammonium compound [100 ppm].

Air dry unit, do NOT wipe.

3. Snap seat cup over stem by applying direct pressure.
4. Screw upper assembly back onto the lower assembly of faucet. **HAND TIGHTEN ONLY.**

NOTE: To dismantle all parts of the faucet upper assembly, apply pressure on the bottom of plastic cup, while pulling on top handle. Reassemble in reverse.

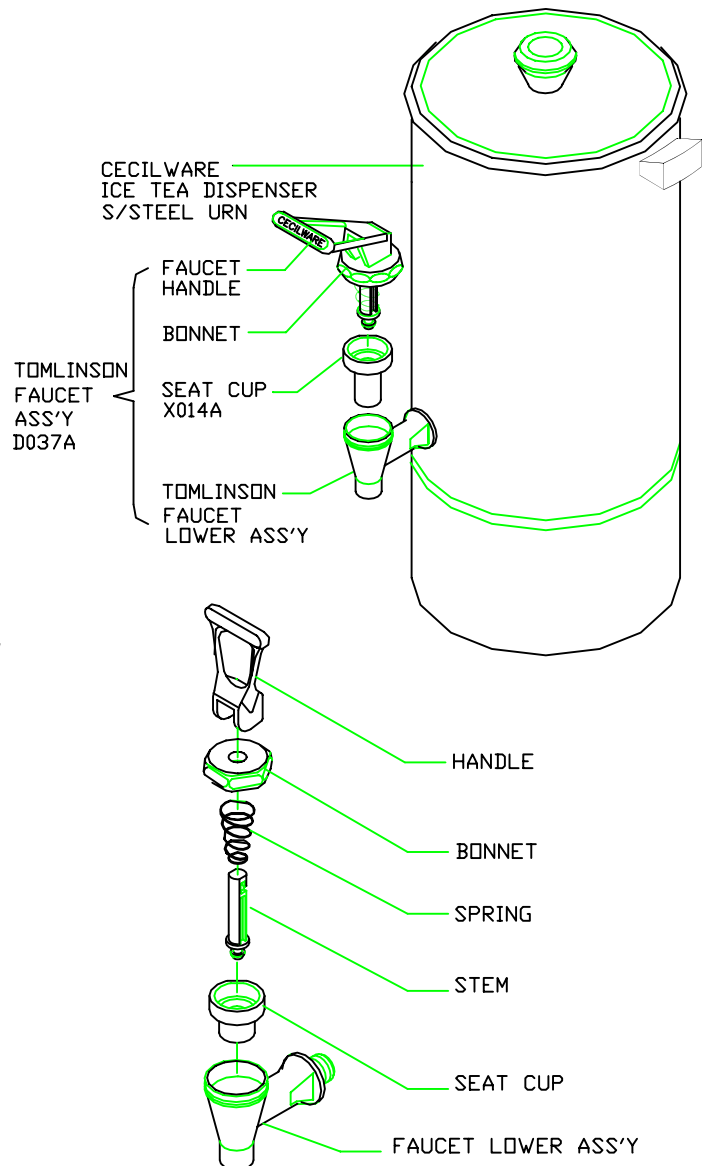

600 Series Pinch Tube Faucet

The Pinch Tube Faucet is used with a super-sanitary, disposable bag and tube. The tube is inserted through the faucet; product does not contact the valve. The pinch tube requires not cleaning.

Faucet Assembly Instructions:

1. Assemble faucet body [1] to existing shank [2]
2. Place handle in lock open position [3].
3. Feed the tube from bag [4] through shank [2] and through faucet body [1].
Pull tube completely through faucet so the bag is flush with the shank on the inside of the container.
4. Return handle to closed position [5].
5. Cut excess tube from bag so only 1/2" extends beyond the end of the faucet.

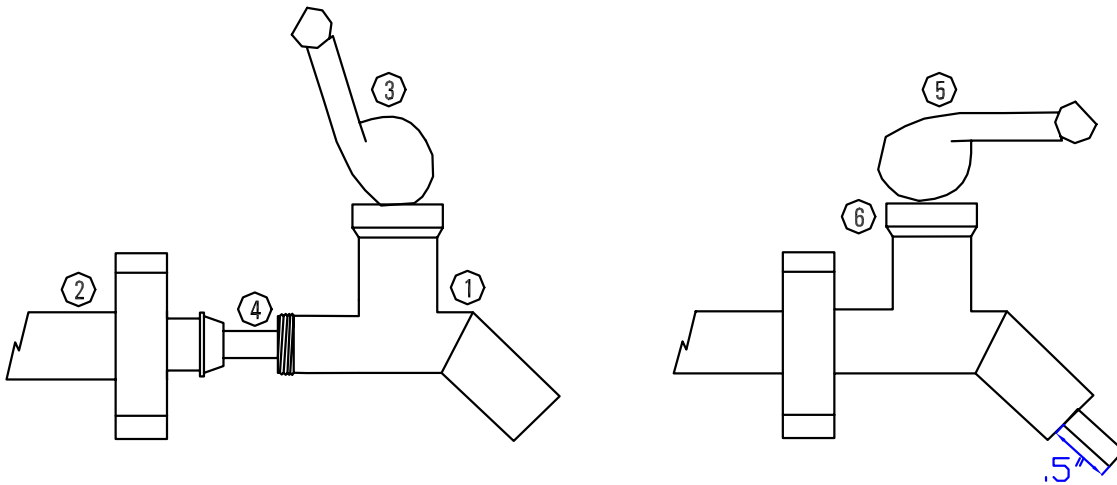

Cleaning Instructions:

Since each bag and tube is discarded after use, this valve requires virtually no daily cleaning. However, should cleaning be required, follow these steps:

With handle in lock open position [3]

1. Remove bag and tube assembly from container.
2. Remove entire upper assembly by unscrewing the bonnet [6].
3. Clean all parts, including faucet body and bushing in hot soapy water.
4. Sanitize with chloring [50 PPM], Iodine [14 PPM], or quaternary ammonium compound [100 PPM].
5. Rinse with clear hot water.
6. Screw upper assembly back onto body [hand tighten only], leaving handle in lock open position [3].
7. Follow assembly steps above.

IMPORTANT: To prevent bacterial growth and protect tea flavor, clean and sanitize tea brewing and storage equipment at least ONCE A DAY according to manufacturer's directions.

TROUBLE SHOOTING GUIDE FOR FTC BREWERS

PROBLEM	PROBLEM CAUSES	REMEDIES
NO WATER WHEN BREW SWITCH IS ACTIVATED	A) DISPENSER UNPLUGGED B) CIRCUIT BREAKER OFF OR TRIPPED C) POWER SWITCH OFF D) INOPERATIVE DISPENSE SWITCH E) INOPERATIVE TIMER F) HOT WATER TANK NOT FULL G) WATER SUPPLY OFF H) INLET SCREEN PLUGGED I) INOPERATIVE INLET WATER VALVE J) LOOSE ELECTRICAL CONNECTION	A) PLUG IT IN B) RESET BREAKER C) PRESS "RED" POWER SWITCH D) REPLACE SWITCH E) REPLACE TIMER F) REFER TO TANK FILLING INSTRUCTIONS G) TURN ON WATER H) REMOVE SCREEN AND CLEAN I) REPLALCE WATER VALVE J) CHECK ALL ELECTRICAL CONNECTIONS FOR CONTACT
WATER DOES NOT SHUT OFF	A) LEAKING INLET WATER VALVE B) BREW SWITCH STUCK C) FAULTY TIMER	A) REPLACE VALVE B) REPLACE SWITCH C) REPLACE TIMER
WATER LEAKS FROM TANK VENT TUBE	A) DILUTION TUBE BLOCKED OR LIMED UP B) VACUUM TEE PLUGGED	A) REMOVE TUBE AND CHECK FOR BLOCKAGE B) REMOVE TEE AND CHECK FOR BLOCKAGE
WATER FROM SPRAY HEAD NOT HOT	A) HEATER SWITCH IN "OFF" POSITION B) INOPERATIVE THERMOSTAT C) INOPERATIVE HEATING ELEMENT D) INOPERATIVE HIGH LIMIT E) LOOSE ELECTRICAL CONNECTION	A) TURN ON SWITCH B) REPLACE THERMOSTAT C) REPLACE HEATING ELEMENT D) REPLACE HIGH LIMIT E) CHECK ALL ELECTRICAL CONNECTIONS
TEA TOO WEAK	A) TOO MUCH WATER (IN EXCESS OF 3 GALLONS) B) ADJUSTOR ASSEMBLY OUT OF ADJUSTMENT C) BREW WATER NOT ENOUGH D) SPRAY HEAD LIMED UP	A) TURN TIMER COUNTER-CLOCKWISE AND REBREW. REPEAT UNTIL DESIRED STRENGTH IS ACHIEVED B) REFER TO ADJUSTOR ASSEMBLY INSTRUCTIONS C) TURN UP THERMOSTAT D) REMOVE SPRAY HEAD AND DELIME. WHEN REPLACING SPRAY HEAD. TIGHTEN ONLY WITH FINGERS
TEA TOO STRONG	A) NOT ENOUGH WATER (LESS THAN 3 GALLONS)	A) TURN TIMER KNOB COUNTER-CLOCKWISE AND RE-BREW. REPEAT UNTIL DESIRED STRENGTH IS ACHIEVED
WATER BOILS	A) MALFUNCTIONING THERMOSTAT B) THERMOSTAT NOT CONTACTING TANK	A) REPLACE THERMOSTAT B) TIGHTEN RETAINING NUTS
FUNNEL OVERFLOWS	A) ADJUSTER ASSEMBLY SET TOO HIGH B) BREW FUNNEL CLOGGED	A) REFER TO ADJUSTOR ASSEMBLY INSTRUCTIONS B) REMOVE RESTRICTOR SCREEN ASSEMBLY & CLEAN

FRESH BREWED ICED TEA BREWER FTC-3, FTC-5,

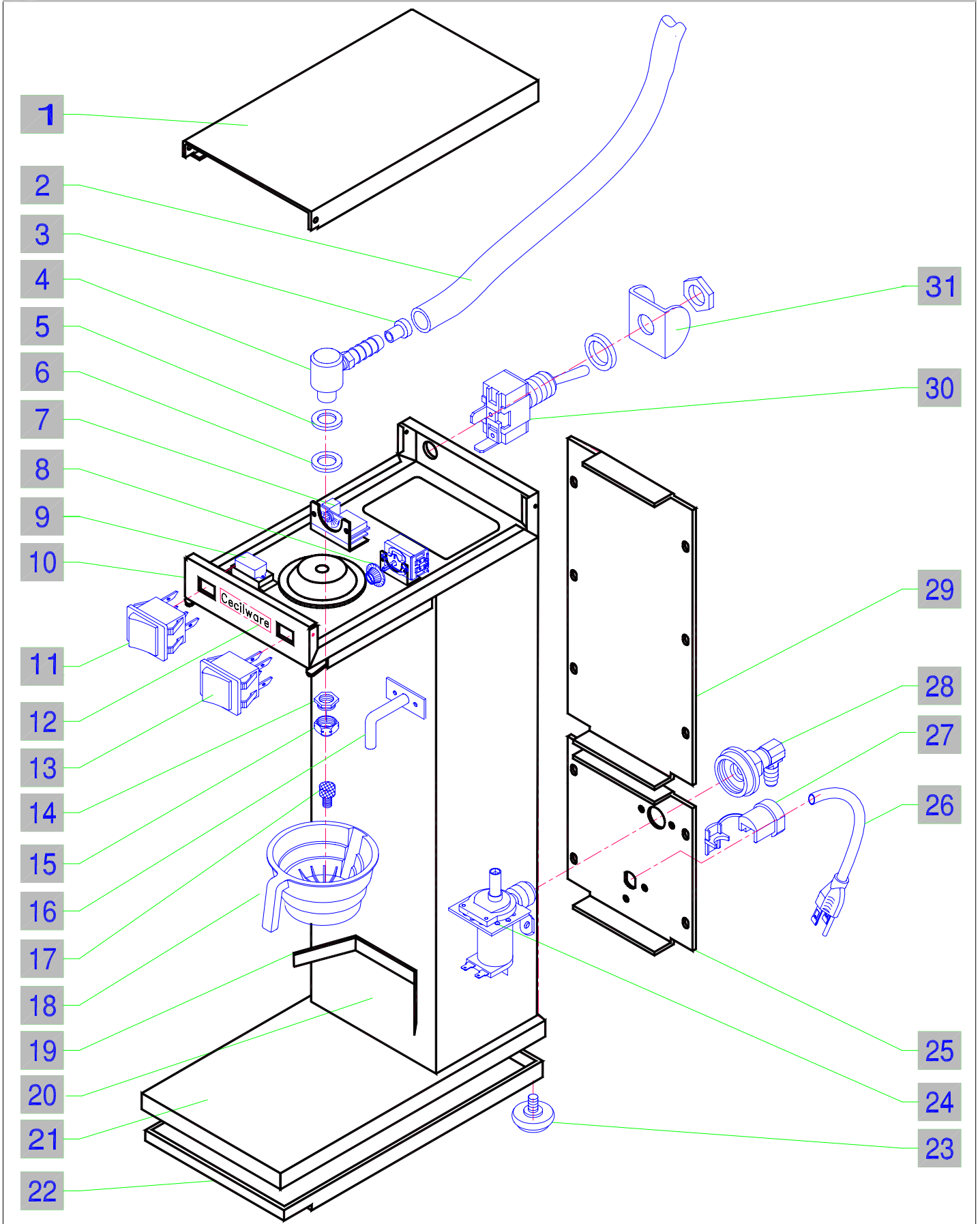

REPLACEMENT PARTS LIST FOR TEA BREWER FTC-3, FTC-5, FTC-5L, FTC-10

ITEM	DESCRIPTION	PART NUMBERS		
		FTC-3	FTC-5 / FTC-5W	FTC-10
1	TOP COVER	40941	40941	R554A
2	HOSE .312 ID. 7.25" LONG	M324A	M324A	M324A
3	FLOW CONTROLLER, HOT SIDE, BLACK [orifice Ø.078]	M647A	M647A	M647A
4	SPRAY HEAD FITTING	95138	95138	95138
5	WASHER FLAT 9/16 ID	P175A	P175A	P175A
6	SILICON WASHER 9/16 ID	M197A	M197A	M197A
7	TIMER 120V ["TEACH ME" TIMER-FTC-10]	L264A or L265A	L201A	L576A
8	THERMOSTAT [WAS 59016- MOUNTED ON TANK]	L532A	L532A	L532A
9	RELAY – TEMPERATURE LOCKOUT – OPTIONAL FEATURE	L539A	L539A	L539A
10	SWITCH PANEL	R741A	R741A	R741A
11	BREW SWITCH 120V	L383A	L383A	L383A
12	DECAL	15547	15547	15547
13	POWER SWITCH 120V	L155A	L155A	L155A
14	SPRAY HEAD NUT	K107A	K107A	K107A
15	SPRAY HEAD	09296	09296	09296
16	DILUTION TUBE ASSEMBLY	97281	H209A	H210A
17	RESTRICTOR W/SCREEN [orifice FTC 3/5 Ø.086 / FTC-10 Ø.187]	K604A	K604A	K626A
18	BREW FUNNEL – WHITE POLYCARBONATE [S.S. FOR FTC-10]	V211A	V211A	Q183A
19	BRACKET, TO CENTER POT	73372	73372	73372
20	TOWER	41023	41023	R533A *
21	BASE TOP	R708A	R708A / RV49A *	R536A *
22	BASE BOTTOM	R709A	R709A / RV50A *	R537A *
	RUBBER BUMPER	M098A	M098A	M098A
23	TINNERMAN NUT	03016	03016	03016
24	WATER VALVE INLET	80235	80235	L022A
25	REAR BOTTOM COVER	41027	41027 / RT90A *	R512A *
26	POWER CORD 120V	C032A	C032A	C032A
27	STRAIN RELIEF 120V	57032	57032	57032
28	HOSE NUT ASS'Y [WATER INLET]	K491A	K491A	K020A
29	BACK PANEL	41024	41024	R534A
30	HEATER SWITCH W/ WASHER AND NUT	L069A	L069A	L069A
31	SWITCH GUARD S.S. [or 15589]	U810A	U810A	U810A

FTC TANK - NON LIPTON UNITS

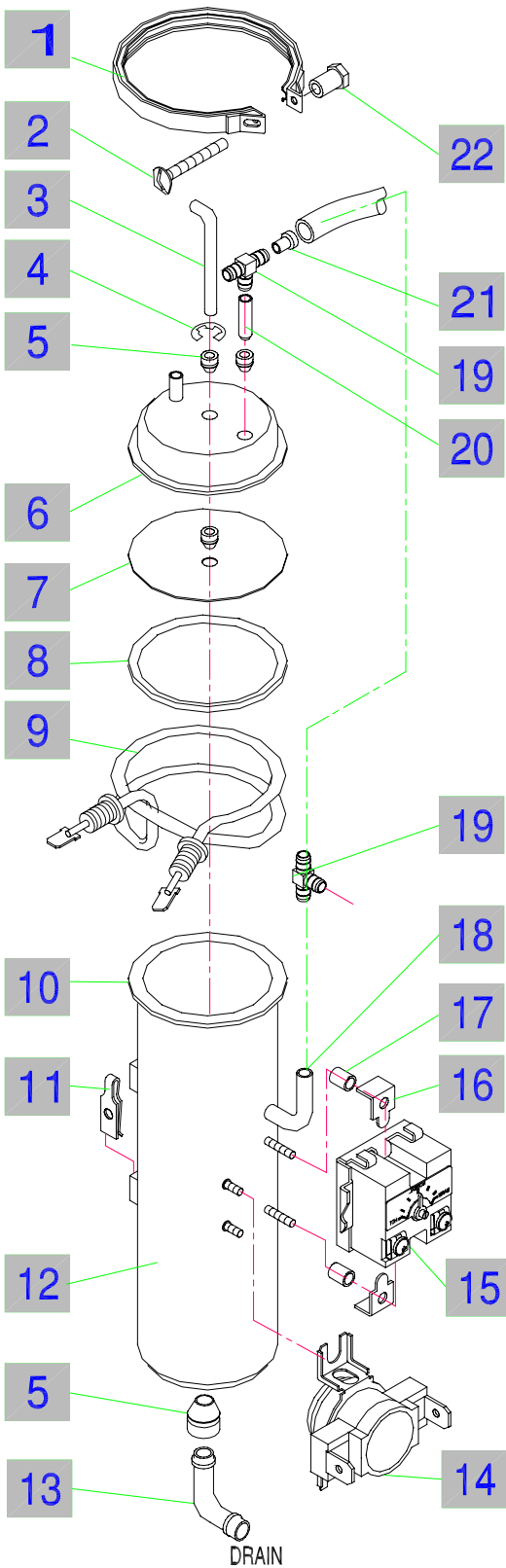

FTC TANK LIPTON UNITS ONLY

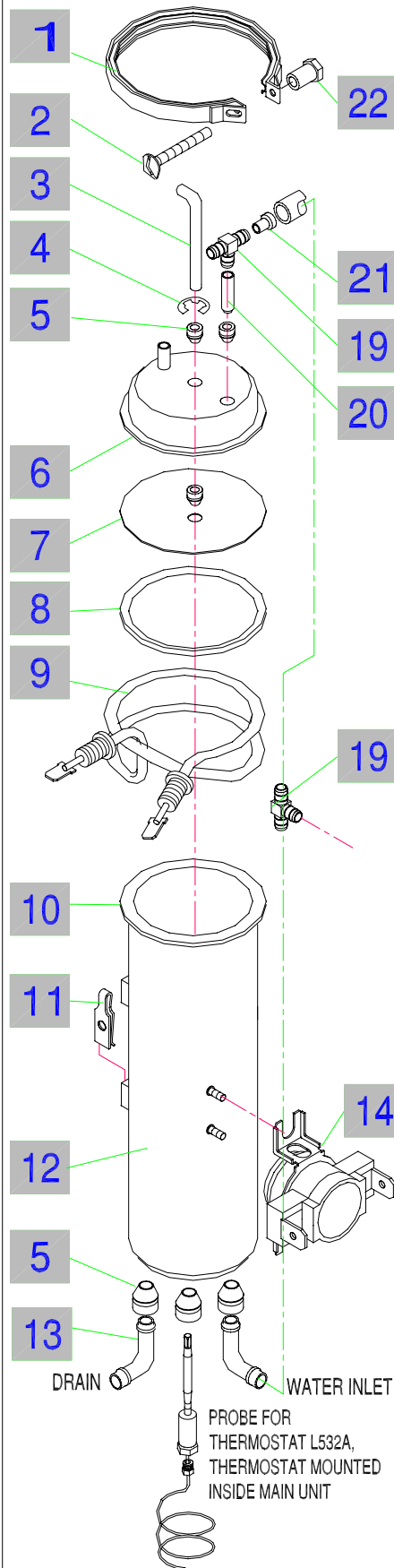

ICED TEA DISPENSER S3C

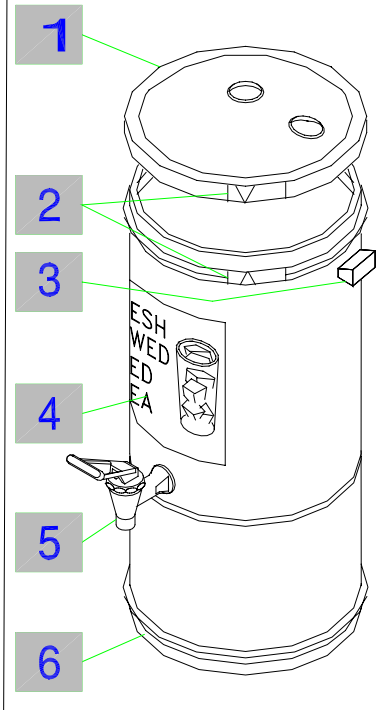

ICED TEA DISPENSER SU-3P

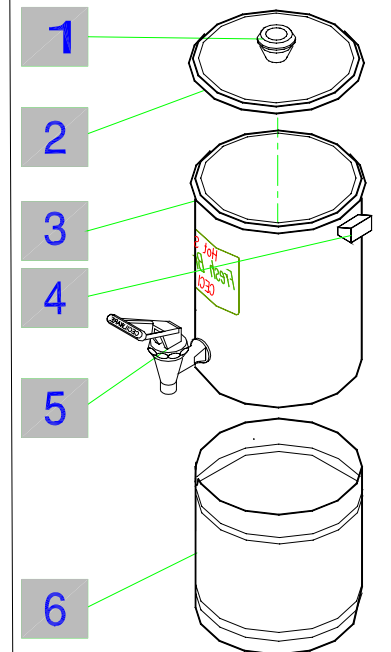

TANK ASSEMBLY

ITEM	PART DESCRIPTION	PART NO.				QTY
		FTC-3	FTC-3 LIPTON	FTC-5	FTC-10	
1	TANK CLAMP	97131	97131	97131	97131	1
2	TANK CLAMP BOLT	06121	06121	06121	06121	1
3	TUBE, WATER OUTLET [TO SIPHONING TUBE]	K538A	K538A	K538A	K538A	4 / 5
4	GRIP RING [WALDES MFR P/N 5555-25H] [.25 ID]	P493A	P493A	P493A	P493A	1
5	GROMMET [.466 ID]	M641A	M641A	M641A	M641A	4 / 5
6	TANK TOP	97214	97214	97214	U781A	1
7	TANK BAFFLE	97215	97215	97215	97215	1
8	TANK BAFFLE SEAL	20039	20039	20039	20039	1
9	ELEMENT 120V - 1800W	87037	87037	G014C	G014A	1
11	TINNERMAN NUT	03011	03011	03011	03011	1
12	TANK ASSEMBLY	97132 / 97300	97132 / 97300	97289	97289	1
13	DRAIN TUBE	80224	80224	80224	80224	1
14	HI-LIMIT CONTROL	59010	59010	59024	59024	1
15	THERMOSTAT	59016	L532A – PROBE ONLY	59016	59016	1
16	THERMOSTAT BRACKET	73276	–	73276	73276	2
17	THERMOSTAT SPACER	38205	–	38205	38205	2
18	HOSE BARB ELBOW	09295	–	09295	09295	1
19	TEE FITTING	10054	10054	10054	10054	2
20	EXPANSION TUBE	97221	97221	K240A	K240A	1
21	FLOW CONTROLLER, COLD SIDE, WHITE, ORIFICE Ø .122	M279A	M279A	M279A	M279A	1
22	TANK CLAMP NUT	03053	03053	03053	03053	1

ICED TEA DISPENSER S3C, S5C, S5W, S10C [ONE PIECE]

ITEM	PART DESCRIPTION	PART NO.				QTY
		S3C	S5C	S5W	S10C	
1	COVER W/KNOB	Q148A	Q102H	Q102H	Q102H	1
	COVER W/HOLES	Q080A				1
2	ARROW ALIGNMENT DECAL	15608	15608	15608	15608	2
3	HANDLE, BLACK	M632A	M632A	M632A	M632A	2
4	FRONT LABEL	15546	15546	15546	15546	1
5	FAUCET	D037A	D037A	D037A	D017A	1
6	BODY WRAP	R068A	R069A	RV51A	R328A	1
	BOTTOM INSERT	Q083A	Q083A	Q124A	Q124A	1

ICED TEA DISPENSER SU-3P, SU-5P [TWO PIECE]

ITEM	PART DESCRIPTION	SU-3P [POT Ø9.5 OD]	SU-5P [POT Ø12.75 OD]	QTY
1	KNOB	M028A	M028A	1
2	COVER W/KNOB OR W/HOLES	Q148C [Ø9.5 ID]	R021A [Ø12.75 ID]	1
3	TANK 3 GAL OR 5 GAL.	Q172A	Q180A	1
4	HANDLE, BLACK	M632A	M632A	2
5	FAUCET	D077A	D077A	1
	FAUCET SHANK	D076A	D076A	1
	SS FAUCET BUSHING	K524A	K524A	1
	RUBBER WASHERS	M080A	M080A	2
	NUT	K110A	K110A	1
6	ROUND STAND	RI65A	RW24A	1

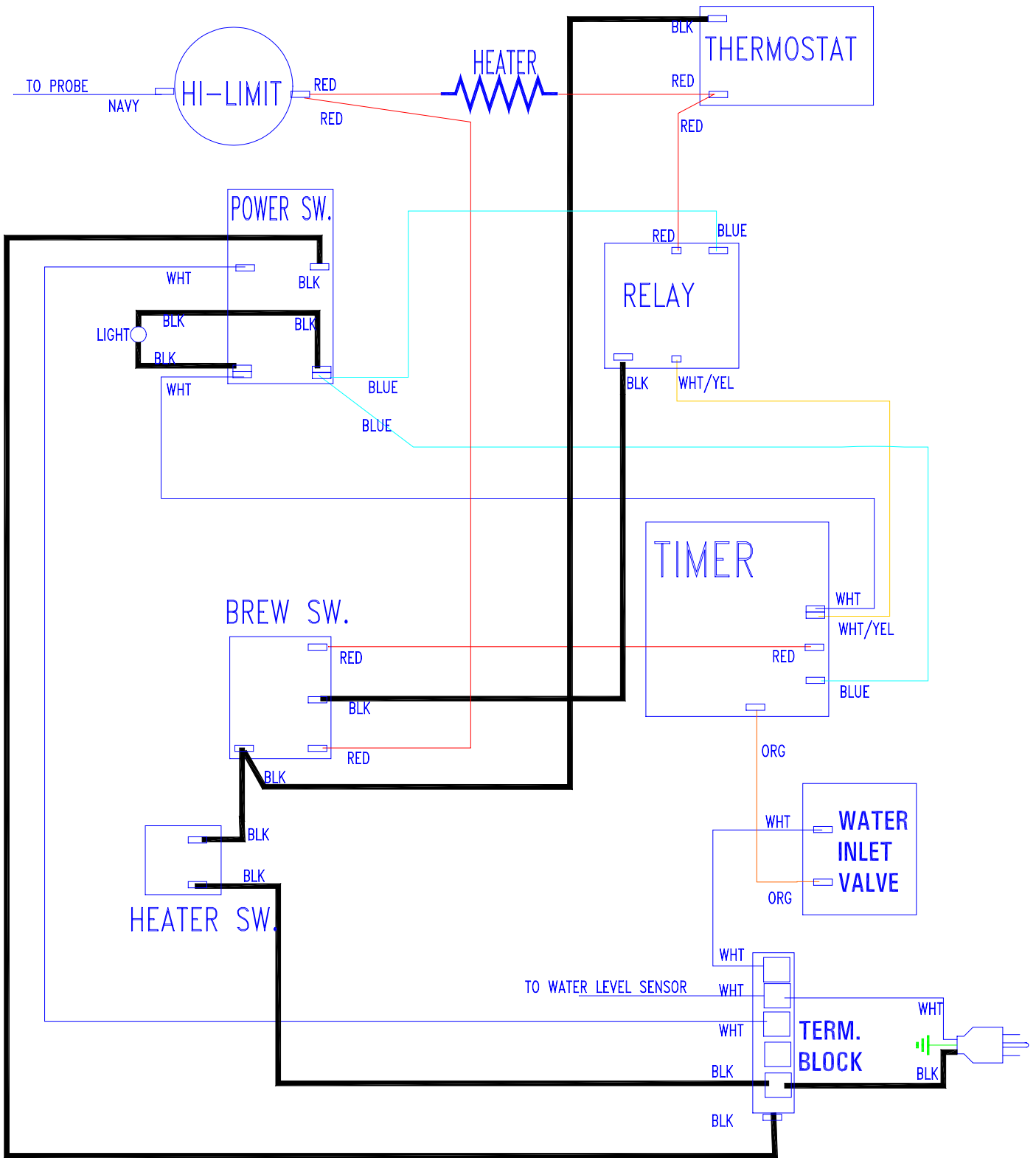

REV	BY	DATE	DESCRIPTION	APPROVED BY	DATE	PART NO. NE70A
MATERIAL:	N/A			DRAWN BY	C.G.	DATE 2/29/98 SCALE N T S
CECILWARE CORPORATION				43-05 20 AVE. L.I.C. NY 11105		
TITLE: ELECTRICAL DIAGRAM FTC-3 W/ TEMP. LOCKOUT RELAY						REV. -



FTC-3P POUROVER