

Operation & Service Manual



FRY-SAVER® Oil Filtration System

MODEL #	OIL CAPACITY	VOLTAGE	SHIP WT.
F-60	60 lbs.	120v/60/1	85 lbs.
F-100	120 lbs.	120v/60/1	95 lbs.
F-150	150 lbs.	120v/60/1	105 lbs.

STANDARD FEATURES:

- All stainless steel body and filter housing construction.
- 1/4 HP heavy-duty reversible pump & motor.
- Built-in suction line heater with indicator light for solid shortening.
- 5-foot (1.5 meter) flexible, sanitary, high temperature hose and heat proof handle assembly.
- Easy to remove pleated filter cartridge for super fine filtering.
- Built-in thermal reset switch.
- Four heavy-duty swivel casters allow easy movement.
- Filters 50 lbs. of oil in 5 minutes.



Cecilware Corporation
43-05 20th Avenue ~ Long Island City, NY 11105
Tel: 800.935.2211 718.932.1414 Fax: 718.932.7860
www.cecilware.com customer.service@cecilware.com

FILTER CARTRIDGE DIRECTIONS:

To insert or replace the filter cartridge in the unit, follow these simple steps:

- 1) Remove cartridge support assembly by lifting straight up, and applying a twisting motion. Discard the used cartridge. Wipe machine down with a clean cloth.

DO NOT USE WATER OR OTHER CLEANING SOLUTIONS WHEN CLEANING THE FRY-SAVER®.

- 2) Place the cartridge support assembly over the center tube in the filter tank. Push down until the cartridge support rests on the bottom of the tank.
- 3) Place the pleated filter cartridge (pleats facing up) over the cartridge support. Push down on the outer rim until the cartridge rests on the support bead.

BE CAREFUL NOT TO DAMAGE PLEATS. Improper handling will crush them.

NOTE: Each filter cartridge can be used to filter up to 1,000 pounds of oil before a new cartridge must be used. This equates to the cartridge being entirely covered with foreign matter.

It is recommended that you only remove and re-insert the cartridge when it needs to be replaced. By continuously removing and re-inserting the cartridge, you will lessen its efficiency by breaking the seal formed around the cartridge diameter. This allows for oil and particles to flow into the filtered oil and re-contaminate the oil.

OPERATING INSTRUCTIONS

Before operating the filter, check the control lever and heater switch to see that they are in the "OFF" position. The drain valve should be in the "CLOSED" position too. The filter cartridge should be inserted as well (SEE FILTER CARTRIDGE DIRECTIONS).

NOTE: The FRY-SAVER® is equipped with a circuit breaker to protect against electric overload or short-circuiting. If the unit is plugged in and does not operate, simply push the circuit breaker button located on the face of the control panel and hold in for a few seconds. If the unit still does not operate, unplug and call either a service technician or our office at 1-800-935-2211 or 718-932-1414. **DO NOT CONTINUE TO PUSH THE BUTTON! THIS WILL HARM THE MOTOR.**

- 1) Turn off the fryer. Wait for the temperature of the oil to cool down to approximately 250° F. If you are using solid shortening, see below.
- 2) Plug the FRY-SAVER® into the correct service outlet.

The FRY-SAVER® is equipped with an additional "pre-heat" feature for when the cooking oil is solidified or thick.

- A) Pre-heat the unit by turning the heater switch to "ON" and allow the unit to heat for approximately 15 minutes. You will know the unit is ready because suction is felt at the nozzle when the control switch is turned to "FILL."
- B) When the machine is pre-heated, turn the heater switch to "OFF" and proceed with filtering.

- 3) Place the nozzle in the cooking oil approximately 2 inches. **DO NOT REST THE NOZZLE ON THE BOTTOM OF THE FRYER.** This will prevent the nozzle from becoming clogged with solid particles.
- 4) Turn the control switch to "FILL", keeping the nozzle tip submerged as oil is pumped into the filter.
- 5) When most of the oil is transferred from the fryer to the filter, turn the control switch to "OFF" and clean the fryer as you normally would. **DO NOT TRANSFER WATER AND SOLID PARTICLES FOUND ON THE BOTTOM OF THE FRYER.** You do not want to mix water and oil together.
- 6) Place the nozzle in the filter tank through the hole in the cover. **DO NOT** rest the nozzle on the cartridge. Turn the control switch to "filter" and allow the oil to pass through the cartridge while you clean the fryer.
- 7) After you have removed most of the oil, only sediment and water is left. Place a container under the drain valve in front of the fryer and open the valve to empty the unit. When the fryer is empty, follow the manufacturer's instructions for cleaning.
- 8) Once the fryer is cleaned, the oil in the FRY-SAVER® tank can be transferred back to the fryer.
- 9) Turn the control switch on the FRY-SAVER® to "OFF" and position the nozzle in the fryer. Switch the control lever to "FILTER" and run until all the cooking oil is transferred back into the fryer. When finished, turn the control switch "OFF" and replace the nozzle in the cover for storage.

Even though you have emptied the FRY-SAVER® of oil, there will still be some residual oil in the valve and hose. This oil must be drained so it does not cause any clogging.

Place a pan or other suitable container under the valve located below the flexible hose connection at the bottom of the filter tank. Turn the valve cock open until dripping stops. Then close the drain valve. **THE DRAIN VALVE MUST BE CLOSED BEFORE FILTERING.**

FRY-SAVER® FILTER CARTRIDGES:

The filter cartridge has an average life of approximately 1,000 pounds of oil before needing to be replaced. If you are uncertain how many pounds you have filtered, the easiest rule of thumb is to replace the cartridge when the pleats are completely filled with sediment.

NOTE: DO NOT CONTINUOUSLY REMOVE AND RE-INSERT THE FILTER CARTRIDGE, AS THIS WILL CAUSE THE SEAL AROUND THE EDGE OF THE PAN TO BECOME STRIPPED.

Two Ways To Extend The Life Of The Cartridge

1. Use the stainless steel pre-filter assembly and pre-filter paper that is available as an accessory
2. Re-use the old cartridge as well as a new one

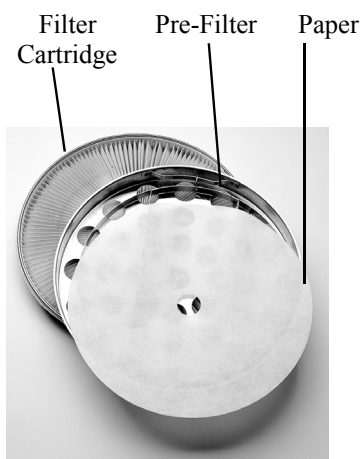

The pre-filter assembly and paper are available from your local dealer and highly recommended to further eliminate larger particles during the filtering process.

To re-use the old cartridge, first remove it from the unit and install a new cartridge. Take the used cartridge and empty out all the particles that have collected in the pleats. Remove the cloth wick around the outside edge of the old cartridge and place it on top of the new cartridge. This will extend the life of the new cartridge.

On the next change of cartridges, remove both the old and the newer discarding the top cartridge. Install the new cartridge on the bottom and place the cartridge that was on the bottom, on the top. This process can be continued indefinitely.

FRY-SAVER® Trouble Shooting Guide

Trouble	Cause	Solution
1) FRY-SAVER® does not start	Power “OFF”	Check that power cord is plugged into the proper outlet and the outlet has current.
	Circuit breaker on the unit may be “OFF”	Check that the “Fill-Filter” switch is in the “OFF” position. Re-set the circuit breaker by pressing the button and holding it for 5 seconds.
	Pump may be jammed	Use hand crank to manually release the pump. Insert the flattened end of the crank onto the pump shaft at the offset vent hole on the bottom of the unit. Turn the crank several times in both directions to release pump. MAKE CERTAIN POWER IS “OFF” BEFOREHAND.
	Solid fat clogged in valve assembly	Turn the heater switch “ON” to pre-heat the fat.
	Motor Burnout	Replace Motor
2) FRY-SAVER® will not fill	Oil temperature is above 250°F.	Allow oil to cool
	Drain valve open	Close the drain valve.
	Loose hose connection	Make certain hose assembly does not have any breaks or loose connections. If hose is cracked, replace hose.
	V-Belt is loose or broken	Tighten V-belt or replace
	Fill-filter switch is not working	Check wiring—if no evidence of loose connection, replace the switch.
3) Gurgling Noise – oil is filling from under the cartridge instead of over the top	Valve assembly is jammed	Contact service agency to repair the raceway.
4) FRY-SAVER® is not filtering	Filter cartridge is clogged	Replace cartridge
	Drain valve open	Close drain
	Loose hose connection	Check hose for breaks and/or loose connections. Replace hose if necessary.
5) FRY-SAVER® leaks at bottom	O-rings in valve assembly are bad	Filtering at excessive temperature. Replace the o-rings.

The **FRY-SAVER** is equipped with an additional crank handle that can be used to free the pump should it become jammed with hardened oil. One or two turns of the pump manually will clear any jammed particles.

Wiring Diagram for Fry-Saver

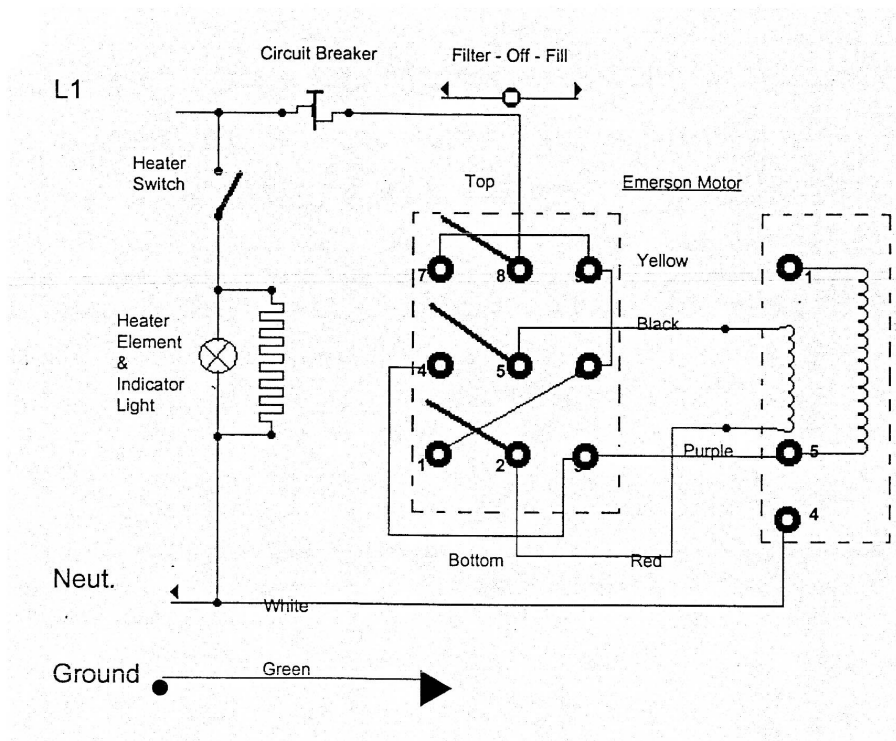

Cecilware Corporation
 43-05 20th Avenue
 Long Island City, NY 11105
 Tel: 718-932-1414
 Fax: 718-932-7860
 www.cecilware.com

Date: 3/1/88 DWG: AE-1A-57

FRY-SAVER® by Cecilware Spare Parts Price List

Cecilware Part #	Blickman Part #	Description
20000	F-101	Filter Cartridge, (1 Dz/Carton)
20003	20000/3	Filter Cartridge (3 Pack)
20005	F-121	Cover w/Knob
20020	F-134-NB	Caster 2", No Brake (4/Set)
20025	F-135	V-Belt, 3L-230
20026	F-135-NUL	V-Belt, 3L-220, For 220v NUL Units
20030	F-140	Valve Assembly, Complete
20035	F-141	Raceway Assembly
20045	F-143	Base Plate, Less Casters
20050	F-144	S/S Ball For Valve Assembly
20055	F-145	Valve Plug
20065	F-146	Heater, 120 Volt
20066	F-146 -NUL	Heater, 220 Volt, NUL
20070	F-147	O-Ring For Cartridge Support
20085	F-151	Motor, 120 Volt, 1/4HP
20086	F-151-NUL	Motor, 220 Volt/50 HZ, 1/4HP
20090	F-152	Sheeve, Pulley
20095	F-156	Catch for Cover (W/Loop)
20100	F-157	Cord Set, 8 FT, 120 Volt, w/Plug
20125	F-171	Cartridge Support, Complete
20130	F-172	O-Ring For Valve Plug
20135	F-181-V	Tubing Bent, Valve To Pump Connection (Viking) - reference last character in serial # of machine
20135	F-181-H	Tubing Bent, Valve To Pump Connection (Haight) -reference last character in serial # of machine
20140	F-182	Compression Fitting, 3/8" Straight
20145	F-183	Compression Fitting, Right Angle
20150	F-185	Fan Blade
20155	F-191	Hose, 5 Ft Neoprene, New Style w/Couplings
20160	F-192	Nozzle, S/S, w/Handle
20165	F-192-7	Grip, For F-192 Nozzle, Black Rubber
20170	F-193-1	Nipple, 1/2 x 4-1/2
20175	F-193-2	Tee Fitting, 3/8 x 1/2
20180	F-193-4	Drain valve
20185	F-194-1A	Switch, Fill/Filter
20190	F-194-1B	Boot, For Fill/Filter Switch
20195	F-194-2	Circuit Breaker
20200	F-194-3	Switch, Heater
20205	F-194-4	Pilot Light
20210	F-199	Hose Assembly, Complete, Nozzle Attached
20215	F-201	Pre-Filter, S/S w/Hold-Down Ring
20220	F-202	Pre-Filter Paper, 150 Sheets Per Case
20225	F-196	Control Box, Complete With All Components
20230	20230	Caster 3", No Brake (4/Set)
20240	20240	Stabilizing Wings For 3" Casters (Model # F-150 Only) *can only be installed at time of order
23090	F-122-1	Knob Only For Cover
2004B	F-142	O-Ring, Thick, For Top Of Valve
2011H	F-160H	Pump, Haight - reference last character in serial # of machine
2011V	F-160V	Pump, Viking - reference last character in serial # of machine
NM25A	F-145-A	Decal, Control Box Cover
20080	F-149	Hand Crank

FRY-SAVER®

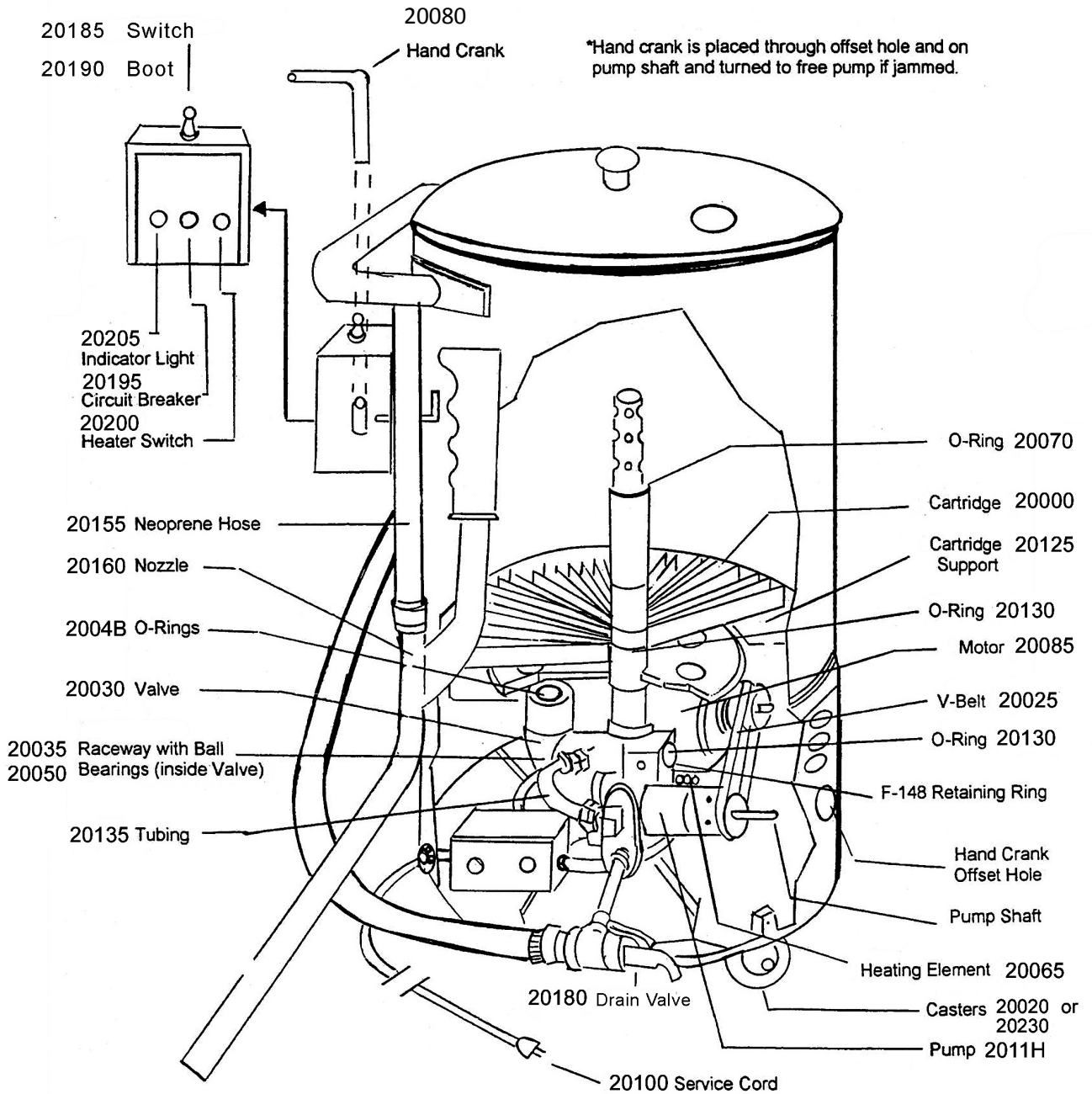

Cecilware Corporation
43-05 20th Avenue
Long Island City, NY 11105
Tel: 718.932.1414 800.935.2211
Fax: 718.932.7860

U.S. Patents:
2,902,161•3,034,827
3,045,928•3,066,656

QUICK TIPS

1. BEFORE FILTERING – TURN FRYER OFF TO COOL THE OIL BELOW 300°.
2. TURN ON THE PRE-HEAT SWITCH LOCATED ON THE FRONT OF THE CONTROL BOX.
3. WAIT AT LEAST 15 MINUTES BEFORE FILTERING.
4. TURN PRE-HEAT SWITCH OFF BEFORE FILTERING.
5. DO NOT STICK NOZZLE TO THE BOTTOM OF THE FRYER.
6. WHEN YOU HAVE REMOVED MOST OF THE OIL FROM THE FRYER, TURN OFF THE FRY SAVER AND INSERT THE NOZZLE THRU THE COVER.
7. TURN THE MAIN SWITCH TO FILTER AND ALLOW THE OIL TO CIRCULATE THRU THE MACHINE WHILE YOU CLEAN THE FRYER.
8. WHEN YOU ARE FINISHED, OPEN THE DRAIN VALVE AT THE END OF THE HOSE, TO REMOVE ANY OIL LEFT IN THE MACHINE.



Cecilware Corporation
43-05 20th Avenue ~ Long Island City, NY 11105
Tel: 800.935.2211 718.932.1414 Fax: 718.932.7860
www.cecilware.com customer.service@cecilware.com