

BREW CENTER IT COFFEE BREWING EQUIPMENT



Models: **Single**

BC301-IT

Twin
BC2-IT
BC302-IT

Manual:

Specifications
Installation
Operating
Instructions
Programming
instructions
Care Maintenance
Adjustments
Parts identifications
Wiring Diagrams



Since 1911

Cecilware Corporation

43-05 20th. Avenue, LIC NY 11105

Tel: 800.935.2211 / 718.932.1414

Fax: 718.932.7860 • www.cecilware.com

Email: customer.service@cecilware.com

Cecilware sells value... Worldwide

Operation Manual

NI90A Jan 2010

To purchase spare parts, please go to www.cecilwarepartsdirect.com

SPECIFICATIONS

ELECTRICAL SPECIFICATIONS

MODEL NO.	BC301-IT	BC2-IT	BC302-IT
Volts	120/230	120/230	120/230
Watts	4100	6200	6200
Amps	18	27	27
Wall Outlet (Receptacle) Power Cord CE202 – 30A optional	6-30R	6-30R	6-30R

All Brew Centers are single phase with 3 wires plus a ground with cord and plug, except Eport 220V, 1 PH, (UROPEAN).

MECHANICAL SPECIFICATIONS

MODEL NO.	BC301-IT (in)	BC2-IT (in)	BC302-IT (in)
Tank Capacity (US gal.)	3.1	6.2	6.2
Cups/Brew Cycle	12/24/36	2 x 36	2 x 12/24/36
Cups/Hour	240	400	400
Height (includes 4" legs)	31	31	31
Width	9 ¼	18	18
Depth (+2"for ¼"water connection)	17 ½	17 ½	17 ½
Ship Weight lbs.	65	105	110

START-UP PROCEDURE

- PLUG THE POWER CORD INTO A PROPER RECEPTACLE.**
- ACTIVATE THE POWER SWITCH ON** (Toggle Up), located in the lower left corner in back of Brewer.
- PUSH THE POWER BUTTON (RED) ON THE TOUCHPAD ON THE FRONT PANEL.**

The power switch controls all power including the Heater Elements in the tank and the Warmers.

The Brewer will automatically start filling the tank, then it will start to heat up the Water in the tank, until it reaches the proper preset temperature (200°F) (About 20 minutes). The LCD window will display a series of messages:

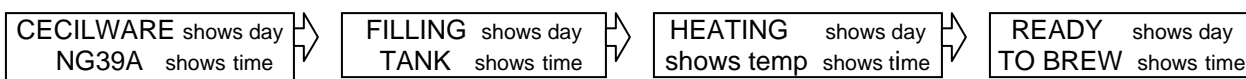

- PLACE PAPER FILTER AND COFFEE IN THE FUNNEL, AND INSERT FUNNEL IN THE BREWER.**
- PUSH THE BREW BUTTON. YOU NEED NOT WAIT FOR THESE MESSAGES TO COME UP FIRST.**

After the brew button is pressed, when the "READY TO BREW" message comes on, the Brewer automatically begins brewing coffee. The LEDs will light up and stay on during the brewing cycle.

NOTE: THE BREWER CAN BE PROGRAMMED TO START ITSELF UP AT ANY DESIRED TIME AND SHUT ITSELF OFF AT ANY DESIRED TIME, PROVIDED THAT THE MAIN POWER SWITCH IN THE BACK OF THE BREWER IS KEPT ON (Toggle Up).

RECOMMENDED COFFEE AMOUNT FOR BREWING

- 2.5 oz. for one (1) decanter, ½ US gal. (12 cups)
- 5 oz. for two (2) decanters, 1 US gal. (24 cups)
- 7.5 oz. for tree (3) decanters, 1½ US gal. (36 cups)

FEATURES AND BENEFITS OF THE DIGITAL, MEMBRANE CONTROL TOUCH PAD BREWER

1. 100% Solid State Control for improved reliability.
2. Modular design and reduced component count for ease of service.
3. Optional Low Water Temperature Lockout to prevent dispensing at water temperatures below an adjustable threshold.
4. Redundant system interlocks for uncompromising user safety.
5. Large two line display for viewing system status on digital display and modifying parameters.
6. Individual brew cycle counters and totalizers for product marketing information and inventory control.
7. Advanced system diagnostics that continuously monitor the status of valves, sensors, and heaters to ensure proper operation and aid in identifying potential problems.
8. Protection from heater burnout due to low water level in the reservoir tank.
9. Stable water temperature regulation with adjustment to one-degree Fahrenheit.
10. Units of measure displayed in either English or Metric.
11. Digital adjustment of brewing size in ounce.
12. Audible alarms: a) When brew cycle is ready b) Warmers Warning "time to brew new batch of coffee".
13. Optional power saving "sleep mode" for extended periods of inactivity (self turn off and on, as programmed).

INSTALLATION AND OPERATING INSTRUCTIONS

Warranty is **void** if the Brewer is connected to any Voltage **other than the Voltage specified on the data label of the Brewer.**

UNPACKING AND INSPECTION

Carefully unpack the Brewer by cutting the straps and lifting the carton off the Brewer.

ASSEMBLY AND SET-UP

The Brewer is shipped complete with:

DESCRIPTION	BC1-301-IT	BC2-IT, 302-IT
Adjustable legs	4	4
Carriers complete with Faucets and Covers	1	2
Funnels with sample Filter pack	1	2

Remove carriers from Brewer, one has the four (4) legs packed inside. Install legs by tilting Brewer on its back and screwing the legs into the threaded leg supports on bottom.

WATER HOOK UP

The National Sanitation Foundation (NSF) requires the following for NSF approved installation:

1. A quick disconnect water connection or enough extra coiled tubing (at least 2x the depth of the unit) so that the Brewer can be moved for cleaning underneath.
2. An approved flow-back prevention device such as a double check valve to be installed between Brewer and water supply.

WATER CONNECTION

The Brewer comes equipped with a ¼ inch compression water inlet fitting located in the back. Use a ¼ inch copper tubing to connect the Brewer to a cold water supply. Water pressure should be: 20 PSI min. to 90 PSI max. An external shut-off valve and a water filtering system with a charcoal filter are highly recommended.

Turn water supply on and check for leaks at the water inlet connections, tighten compression fitting if necessary.

ELECTRICAL CONNECTIONS

A terminal block inside the base compartment is provided for electrical connections. Opening for field conduit connections are provided in the bottom and the back of the base.

To access the Terminal Block, loosen the 2 screws on the side of the base cover. Disengage base cover from rear panel by lifting base cover up and lifting back towards rear panel.

Power Cord CE202 - Optional

RECOMMENDED WIRING SIZES

Model No.	Single (1) Phase
BC301-IT	12 AWG
BC2-IT, BC302-IT	10 AWG

Note:

1. Neutral (**N**) and Ground Wires to be 14 AWG Minimum.
2. Field wiring must be suitable for 75° C.
3. Use Copper wire only for all power supply connections.

PROGRAMMING INSTRUCTIONS

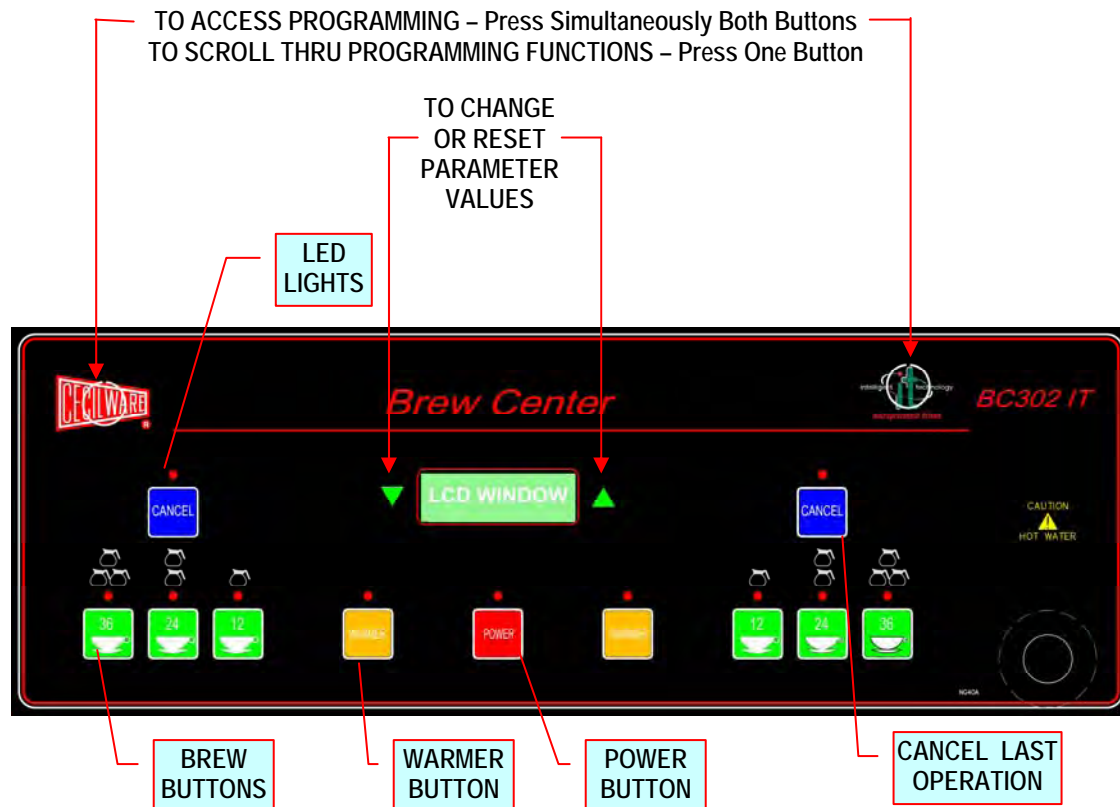

The following is a **Functional Description** of the **Single Station Brewer**:

Modes of Operation - Overview

Initialization Mode – This mode is only active during the first few seconds after a “power-on” or system reset. The main function of this mode is to perform some special self-testing functions and configure the system using the previously saved operating parameters.

Normal Mode – This mode becomes active immediately after Initializing Mode has completed its tasks. The main functions of this mode are to monitor and report system status and control brewing.

Service Mode – This mode becomes active when the hidden keys under the Cecilware Logo (located on the upper-left-hand side of the keypad) and the first letter of the Model Name (located on the upper-right-hand side of the keypad) are simultaneously depressed for more than two seconds while in Normal Mode. The main function of this mode is to allow access (for qualified personnel) to all system parameters that can be modified.

Error Mode – This mode becomes active when the system detects a fatal error. The main function of this mode is to disable the unit and report the error to the operator.

MODES OF OPERATION – DESCRIPTIONS

Initialization Mode: The following screen signifies the presence of this mode:	CECILWARE &&&& REV #.#
Description – This mode is active only during the first few seconds after “power-on”. The purpose of the Initialization Screen is to identify the System Software Title (depicted by “&&&&”) and Revision Number (depicted by “#.#”).	
Normal Mode: The following screen signifies the presence of Normal Mode:	SSSSSS DDD K SSSSSS HH:MMP
Description – Normal Mode is active immediately after Initialization Mode. The left half of the screen displays the present System State (depicted by “S”). Refer to the subsequent State Descriptions in this section for more information on System States. The right half of the screen displays the present day of the week (depicted by “D”), the present time (depicted by “HH”:”MMP”), and the current Key Lock Status (depicted by “K”). The day of the week is identified using familiar three letter abbreviations. The time is identified using hours and minutes along with a “AM/PM” indicator. If KeyLock is enabled the” KL” symbol will be present. Enabling KeyLock will prevent unauthorized users from operating the unit. Refer to the Service Mode Descriptions for more information on the KeyLock function.	
Filling State	FILLING DDD K TANK HH:MMP
Description – This screen is displayed during the initial filling of the water tank (<i>first fill</i>). Once the water in the reservoir tank has reached the appropriate fill level this screen is retired.	
Heating State:	HEATING DDD K TTTT HH:MMP
Description – This screen is displayed when the present water temperature is below the Lockout Temperature Set Point. The actual water temperature is displayed in the lower left-hand portion of the screen (depicted by “TTTT”). If the Brew Key is depressed while in the Heating State the system will advance to the Waiting State. If the Brew Key is depressed for more that three seconds the Waiting State is bypassed and the system will advance to the Brewing State.	
Waiting State	WAITING DDD K TTTT HH:MMP
Description – This screen is displayed when the operator presses the Brew Key while the system is in the Heating State. The actual water temperature is displayed in the lower left-hand portion of the screen (depicted by “TTTT”). The Brew Key LED will blink in this state. Once the water temperature reaches the Lockout Temperature Set Point the system will automatically advance to the Brewing State. Pressing the Brew Key or the Cancel Key while in the Waiting State will cause the system to revert back to the Heating State.	
Ready (to Brew) State	READY DDD K TO BREW HH:MMP
Description – This screen is displayed when the system is ready to begin a Brew Cycle. Pressing the Brew Key while in the Ready State will advance the system to the Brewing State (i.e. begin a Brew Cycle).	
Brewing State	BREWING DDD K MM:SS HH:MMP
Description – This screen is displayed when a Brew Cycle is in progress. The time remaining in the Brew Cycle is displayed in the lower left-hand corner of the screen (depicted as “MM:SS”). The Brew Key LED will blink in this state. The Main Warmer is automatically activated upon entry into this state. The Brewing parameters of Brew Size, Dilution, Pre-Infusion, Pulse Brew, and Drip Time are utilized in this state. Refer to the Service Mode Descriptions for more information on Brew parameters. Pressing the Brew Key or the Cancel Key while in the Brewing State will abort the Brew Cycle and revert the system to the Ready State.	
Brew Fill Constant Calibration State	--

Description – The Brew Fill Constant Calibration State is entered from the Heating State or the Ready State by simultaneously pressing the [Down Arrow] Key and the Brew Key. The system will immediately energize the Dump Solenoid (and dispense hot water) for exactly 10 seconds. The required Brew Fill Constant can be verified by dividing the volume of hot water dispensed by 10 thus yielding the actual Brew Fill Constant in ounces per second.

Dilution Fill Constant Calibration State

Description – The Dilution Fill Constant Calibration State is entered from the Heating State or the Ready State by simultaneously pressing the [Up Arrow] Key and the Brew Key. The system will immediately energize the Dilution Solenoid (and dispense hot water) for exactly 10 seconds. The required Dilution Fill Constant can be verified by dividing the volume of hot water dispensed by 10 thus yielding the actual Dilution Fill Constant in ounces per second.

Warmers

Description – The warmers are generally controlled manually via the Warmer Keys on the keypad. The only situation when this is not the case is during a Brewing Cycle. The Main Warmer is automatically turned ON when the system enters the Brewing State. Each Warmer has an optional timer, power level, audible alarm, and power reduction feature associated with it. The Warmer Timer is particularly useful to indicate when a brew has become stale. Refer to the Service Mode Descriptions for more information on Warmer options.

Real-Time-Clock

Description – The Real-Time-Clock (RTC) allows the system to automatically turn ON at a specified time (usually in the morning) and turn OFF at a specified time (usually at night). The RTC also has separate settings for weekdays and weekends. This feature eliminates the wait associated with heating up the reservoir tank every morning. Refer to the Service Mode Descriptions for more information on Real-Time-Clock parameters.

SERVICE MODE

Description – The main function of Service Mode is to give qualified personnel the ability to configure the system to meet the requirements of each installation.

General Conventions (unless otherwise indicated)

- 1) To enter or exit Service Mode simultaneously depress both the hidden key under the Cecilware Logo (CW Key) and the hidden key under the first letter of the Model Name (MN Key) until the buzzer sounds (approximately two seconds).
- 2) Depressing the MN Key will cause the menu to scroll up and depressing the CW Key will cause the menu to scroll down.
- 3) Depressing the [Up Arrow] Key or [Down Arrow] Key individually will increase, decrease, or toggle the displayed parameter respectively.
- 4) Simultaneously depressing both the [Up Arrow] Key and the [Down Arrow] Key is used to acknowledge a request for confirmation (i.e. ARE YOU SURE?).
- 5) Modified parameters are saved upon scrolling to a different menu.
- 6) The system will automatically exit Service Mode and enter Normal Mode if the keypad remains idle (i.e. no keys are pressed) for more than three minutes.

KEYLOCK	KEYLOCK ON/OFF
Description – The KeyLock feature disables all keys on the keypad except the Power Key. This feature prevents unauthorized users from tampering with the controls. For user convenience a method has been provided to temporarily override KeyLock. While depressing the hidden Cecilware (CW) Key the KeyLock feature is disabled. This allows authorized users to easily start a Brew Cycle while preventing unauthorized users from doing the same. The presence of the “KL” symbol on the screen in Normal Mode indicates the status of KeyLock (see Normal Mode Descriptions).	
DISPENSE TOTAL	DISPENSE TOTAL ##### OZ
Description – The Dispense Total is the total volume of hot water automatically dispensed since the machine was assembled at the factory. <i>This value cannot be changed or reset!</i>	
BREW CYCLES	BREW CYCLES #####
Description – The Brew Cycles screen displays the value of the Brew Cycle Counter. The Brew Cycle Counter contains the total number of completed Brew Cycles since the counter was last reset. The Brew Cycle Counter can be reset (set to zero) by simultaneously depressing the [Up Arrow] Key and [Down Arrow] Key for approximately two seconds.	
BREW SIZE	BREW SIZE ###.# OZ
Description – The Brew Size is the required volume of hot water dispensed during each Brew Cycle.	
BREW FILL CONSTANT	BREW FILL CONST ###.# OZ/SEC
Description – The Brew Fill Constant is the exact value of the rate at which hot water is dispensed from the Dump Solenoid Valve during each Brew Cycle. <i>The accuracy of this value is crucial to the proper operation of this system.</i> This value is directly related to the orifice size of the Dump Solenoid Valve. A simple method for calibrating the Dump Solenoid Valve has been provided in Normal Mode (see Brew Fill Constant Calibration section of Normal Mode Descriptions).	
PRE-INFUSION	PRE-INFUSION ON/OFF
Description – The Pre-Infusion feature gives the user the ability to “wet” the grinds for a period of time (Infusion Time) and then allow the grinds to “soak” for a period of time (Soak Time) before brewing.	
INFUSION TIME	INFUSION TIME ## SECONDS
Description – The Infusion Time is the amount of time that the system will dispense (infuse) hot water into the grinds during the Pre-Infusion process.	

SOAK TIME	SOAK TIME ## SECONDS
Description – The Soak Time is the amount of time that the system will wait between the end of the hot water infusion period and the beginning of brewing.	
PULSE BREW	PULSE BREW ON/OFF
Description – The Pulse Brew feature gives the user the ability to brew by non-continuously dispensing (pulsing) hot water.	
PULSE ON TIME	PULSE ON TIME ## SECONDS
Description – The Pulse ON Time is the amount of time that the system will continuously dispense hot water during a Brew Cycle.	
PULSE OFF TIME	PULSE OFF TIME ## SECONDS
Description – The Pulse OFF Time is the amount of time that the system will wait between hot water dispenses during a Brew Cycle.	
DRIP TIME	DRIP TIME ### SECONDS
Description – The Drip Time is the amount of time that the system will wait after the completion of the hot water dispense before signaling the end of the Brew Cycle. This allows time for any water remaining in the funnel to drain out.	
DILUTION	DILUTION (36) ON/OFF
Description – The Dilution feature gives the user the ability to add hot water directly to the brew without passing through the grinds. <i>This option is only available in models with a 36-Cup Dispense Key.</i>	
DILUTION PERCENT	DILUTION PERCENT ## %
Description – The Dilution Percent is the percentage of the total volume of the brew (Brew Size) that is diluted	
DILUTION FILL CONSTANT	DIL FILL CONST #.# OZ/SEC
Description – The Dilution Fill Constant is the exact value of the rate at which hot water is dispensed from the Dilution Solenoid Valve during each Brew Cycle. <i>The accuracy of this value is crucial to the proper operation of this system.</i> This value is directly related to the orifice size of the Dilution Solenoid Valve. A simple method for calibrating the Dilution Solenoid Valve has been provided in Normal Mode (see Dilution Fill Constant Calibration section of Normal Mode Descriptions).	
DILUTION DELAY	DILUTION DELAY ### SECONDS
Description – The Dilution Delay is the amount of time the system waits from the start of Brewing to the start of Dilution.	
WATER TEMPERATURE	WATER TEMP ### °F
Description – The Water Temperature is the required (set point) temperature of the water in the reservoir tank.	
TEMPERATURE SENSOR CALIBRATION	TEMP SENSOR CAL ARE YOU SURE ?
Description – The Temperature Sensor Calibration allows the user to offset (calibrate) the displayed water temperature to a reference thermometer.	
<i>Instructions</i> – Use the [Arrow] Keys to adjust (calibrate) the displayed temperature to match the reference thermometer. Depress one of the [Hidden] Keys when the calibration is complete.	TEMP SENSOR CAL ### °F
LOCKOUT TEMPERATURE	LOCKOUT TEMP ### °F
Description – The Lockout Temperature is the minimum brewing temperature. The system will not allow a Brew Cycle to begin unless the water is above the Lockout Temperature.	

SLEEP TIMER	SLEEP TIMER ON/OFF
Description – The Sleep Timer feature automatically reduces the water temperature to three degrees above the Lockout Temperature if the machine has not started a Brew Cycle within two hours.	
WARMER POWER	WARMER POWER ### %
Description – The Warmer Power feature allows the user to reduce the actual heating power of the warmers. The percentage displayed is percentage of maximum power.	
WARMER TIMER	WARMER TIMER ON/OFF
Description – The Warmer Timer feature allows the user to set the maximum length of time a brew remains fresh while being warmed. Once the Warmer Timer has expired an alarm is generated. An alarm consists of a blinking warmer LED and (optionally) the audible alarm (buzzer) sounding. The Warmer Timer is reset (restarted) by cycling the warmer Off and On.	
AUDIBLE ALARM	AUDIBLE ALARM ON/OFF
Description – The Audible Alarm feature allows the user to enable/disable the buzzer from indicating that the Warmer Timer has expired.	
WARMER TIME	WARMER TIME ### MINUTES
Description – The Warmer Time is the length of time that a warmer can be continuously energized before an alarm is generated.	
WARMER REDUCTION	WARMER REDUCTION ON/OFF
Description – The Warmer Reduction feature allows the user to gradually reduce the actual heating power of the warmers. This reduction of power is taken over the Warmer Timer period.	
REDUCTION PERCENTAGE	REDUCTION PCT ### %
Description – The Reduction Percentage is the percentage of Warmer Power that is gradually reduced over the Warmer Time.	
WEEKDAY TIMER	WEEKDAY TIMER ON/OFF
Description – The Weekday Timer function allows the system to automatically turn ON at a specified time and turn OFF at a specified time every weekday (Monday – Friday).	
WEEKDAY TIME ON	WEEKDAY TIME ON ##:## #M
Description – The Weekday Time ON function allows the user to set the required weekday turn ON time.	
WEEKDAY TIME OFF	WEEKDAY TIME OFF ##:## #M
Description – The Weekday Time OFF function allows the user to set the required weekday turn OFF time.	
WEEKEND TIMER	WEEKEND TIMER ON/OFF
Description – The Weekend Timer function allows the system to automatically turn ON at a specified time and turn OFF at a specified time every weekend (Saturday - Sunday).	
WEEKEND TIME ON	WEEKEND TIME ON ##:## #M
Description – The Weekend Time ON function allows the user to set the required weekend turn ON time.	
WEEKEND TIME OFF	WEEKEND TIME OFF ##:## #M
Description – The Weekend Time OFF function allows the user to set the required weekend turn OFF time.	
CLOCK SETUP	CLOCK SETUP ON/OFF
Description – The Clock Setup function allows the user to adjust (set and calibrate) the systems Real-Time-Clock.	

ADJUST SECONDS	ADJUST SECONDS DAY HH:MM:##
Description – The Adjust Seconds function allows the user to adjust (set) the systems Real-Time-Clock Seconds placeholder.	
ADJUST MINUTES	ADJUST MINUTES DAY HH:##:SS
Description – The Adjust Minutes function allows the user to adjust (set) the systems Real-Time-Clock Minutes placeholder.	
ADJUST HOURS	ADJUST HOURS DAY ##:MM:SS
Description – The Adjust Hours function allows the user to adjust (set) the systems Real-Time-Clock Hours placeholder.	
ADJUST DAY	ADJUST DAY ### HH:MM:SS
Description – The Adjust Day function allows the user to adjust (set) the systems Real-Time-Clock Day placeholder.	
CLOCK CALIBRATION CONSTANT	CLOCK CAL CONST ##
Description – The Clock Calibration Constant function allows the user to calibrate the systems Real-Time-Clock (RTC). Each unit corresponds to approximately five seconds per month. Thus, if the RTC is running five seconds slow per month then the Clock Calibration Constant needs to be increased by one. Conversely, if the RTC is running five seconds fast per month then the Clock Calibration Constant needs to be decreased by one.	
UNITS	UNITS ENGLISH/METRIC
Description – The Units function allows the user to select English (oz, °F) or Metric (mL, °C) units of measure.	
DEFAULT VALUES	DEFAULT VALUES ARE YOU SURE ?
Description – The Default Values function allows the user to set all system parameters back to their Factory Default Settings. This provides a known (reference) configuration for troubleshooting purposes.	
	DEFAULT VALUES COMPLETED

ERROR MODE

<p>Description – The main function of Error Mode is report any system malfunctions and to disable the unit The system must be “powered down” using the Power Key located on the membrane keypad to reset any reported error</p>	
KEYPAD	! SYSTEM ERROR ! KEYPAD
<p>Description – This screen is displayed and the unit is disabled when a key-press is detected during the initial application of power to the system. This test is <i>not</i> performed during a Power Key initiated “power-on” sequence. Possible Causes – Membrane Keypad or someone depressing a key while applying power to the system</p>	
110/220VAC ON	! SYSTEM ERROR ! 110/220VAC ON
<p>Description – This screen is displayed and the unit is disabled when line voltage is detected before the Safety Relay is energized. Possible Causes – Wiring or Safety Relay</p>	
110/220VAC OFF	! SYSTEM ERROR ! 110/220VAC OFF
<p>Description – This screen is displayed and the unit is disabled when line voltage is <i>not</i> detected after the Safety Relay is energized. Possible Causes – Wiring, Fuse, High Temp Limit Switch, Control Card, or Safety Relay</p>	
HIGH WATER TEMP	! SYSTEM ERROR ! HIGH WATER TEMP
<p>Description – This screen is displayed and the unit is disabled when the present water temperature is sensed as being higher than 208 °F. Possible Causes – Wiring, Power Triac, Control Card, or Water Temperature Sensor</p>	
OVER FLOW	! SYSTEM ERROR ! OVER FLOW
<p>Description – This screen is displayed and the unit is disabled when the Over Flow Level Sensor is detecting the presence of water. Possible Causes – Wiring, Fill Solenoid, Control Card or Level Sensor</p>	
NO FILL RESPONSE	! SYSTEM ERROR ! NO FILL RESPONSE
<p>Description – This screen is displayed and the unit is disabled when the Fill Solenoid has been continuously energized (open & filling) for more than 15 minutes during the <i>first fill</i> or more than 30 seconds thereafter. Possible Causes – Water Supply is turned off, Wiring, Control Card, Fill Solenoid, or Level Sensor</p>	
NO TEMP RESPONSE	! SYSTEM ERROR ! NO TEMP RESPONSE
<p>Description – This screen is displayed and the unit is disabled when the Water Heater has been continuously energized (heating) for more than 45 minutes. Possible Causes – Wiring, Control Card, Water Temperature Sensor, Power Triac, or Water Heater</p>	
DUMP #1 CLOSED	! SYSTEM ERROR ! DUMP #1 CLOSED
<p>Description – This screen is displayed and the unit is disabled when the system has been brewing (dispensing) for more than one minute and the Level Sensor has not sensed the absence of water. Possible Causes – Wiring, Control Card, or Dump Solenoid.</p>	
TEMP SENSOR	! SYSTEM ERROR ! TEMP SENSOR
<p>Description – This screen is displayed and the system is shut down when the Water Temperature Sensor is detecting an invalid (below 32°F or above 220°F) water temperature. Possible Causes – Wiring, Control Card, or Temperature Sensor.</p>	

TROUBLESHOOTING GUIDE

WARNING: To reduce the risk of electrical shock unplug the dispenser power cord before repairing or replacing any internal components of the unit.. Before any attempt to replace a component be sure to check all electrical connections for proper contact

PROBLEM	PROBABLE CAUSE	REMEDY
1. No power to the machine.	a) Loose wire connection. b) Inoperative Power Safety Relay c) Blown fuse.	a) Check wire connections to Relay. See Power Safety Relay Test. b) Replace Power Safety Relay, if inoperative. c) Check fuse.
2. Machine keeps repeating cycle.	a) Touch Pad defective. b) Inoperative Power Safety Relay.	a) Replace Touch Pad. b) Replace Relay.
3. Water does not shut off. Water keeps running into funnel.	a) Leaking Water Inlet Valve [Solenoid]. b) Inoperative Switches on Touch Pad. c) Clogged Dispense Valve	a) Clean/check fittings of Valve. Replace Valve if needed. See "Water Inlet Valve Test" b) Check Touch Pad connections. Replace Touch Pad if needed. c) Clean Dispense Valve. Replace Dispense Valve if inoperative.
3. Water will not stop flowing into tank.	a) Water Level Probe malfunction. b) Water Inlet Valve malfunction..	a) Check Probe. Replace if necessary. See "Probe Test" b) Check Solenoid. Replace if necessary. See "Water Inlet Valve Test"
4. Water drips from brew funnel.	a) Leaking Dispense Valve. b) Too much water in tank. c) Spray Head Fitting is clogged. d) Water Valve blocked by scales.	a) Replace Water Dispense Valve. b) Dispense some water from tank. c) Clean Spray Head Fitting. d) Replace or clean Valve Seat.
5. No water is going into tank at all.	a) Water Inlet Valve (Solenoid) malfunction. b) Water Level Probe malfunction.	a) Check Water Inlet Valve. Replace if necessary. See "Water Inlet Valve Test" b) Check Probe. Replace if necessary. See "Probe Test".
6. Water is not heating up in the water tank.	a) Temperature setting is incorrect. b) Loose connection to Heating Element or Heater Safety Relay. c) Heater is burned out or defective. d) Inoperative Heater Safety Relay.	a) Set Temperature at 200°F – See Programming Instructions. b) Make sure all wires are tight. c) Replace the Heater. d) Replace Heater Safety Relay, if inoperative. See Heater Safety Relay Test.
7. Cold coffee.	a) Run out of hot water in tank. b) Temperature setting is incorrect. c) Loose electrical connection. d) Bad or burnt out Heating Element.	a) Allow time for water in tank to heat after filling. b) Set temperature at 200°F. (See Programming Instructions) c) Check all electrical connections for contact. d) Replace Heater.
8. Coffee too strong.	a) Water flow too low. b) Too much coffee in the brew funnel.	a) Adjust water flow rate on Dispense Valve. b) Put the proper amount of coffee in funnel. See suggested amount.
9. Coffee too weak.	a) Not enough coffee in the brew funnel. b) Water flow too high.	a) Add coffee. b) Adjust water flow rate on Dispense Valve.

SPECIAL COMPONENTS TEST AND ADJUSTMENTS

1) WATER INLET VALVE (SOLENOID) TEST (Located inside bottom cabin)

Turn power off from touchpad. If the water level rises inside the tank, and shoots out of the overflow, the Water Inlet Valve is leaking. Disconnect wires from the Water Inlet Valve coil and connect a 2 wire line cord to the terminals. Plug it into a 115V outlet. If water flows in and stops when you pull it out, the Valve is working fine. Repeat this test a few times. The problem may be in the Probe. If the water does not flow in when the cord is plugged into an electrical outlet, the Solenoid coil may be damaged, opened or the valve may have an obstruction preventing the water from flowing in. Clean or replace it.

A Check Valve is installed to prevent backflow.

To check proper function of Check Valve, disconnect water line from the Check Valve, check for dripping from the disconnected end of the Check Valve. If it leaks replace it.

Water inlet Valve max. flow rate is 1.3 gal/min.

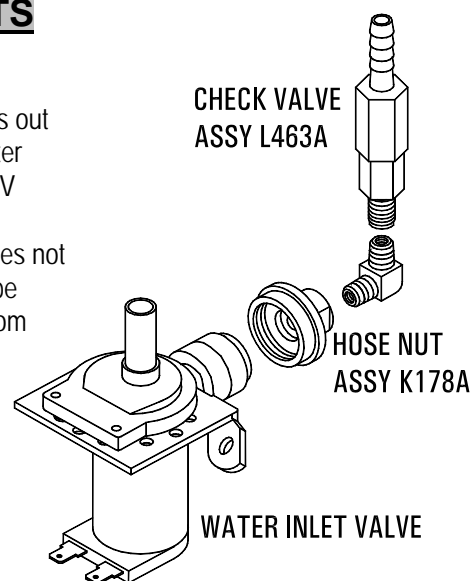

2) WATER LEVEL PROBE TEST (Located on tank top, inside top cabin)

If there is a lack of water, you will get an error message on the LCD window.

Check the probe as follows:

Turn on the power from touchpad and water supply. Check inside the tank to make sure the water is not touching the Probe. Pull the wire and terminal out of the Probe rod. If water starts flowing into the tank, the Probe may be grounded, due to excessive liming. Check with Ohm meter. Clean or replace.

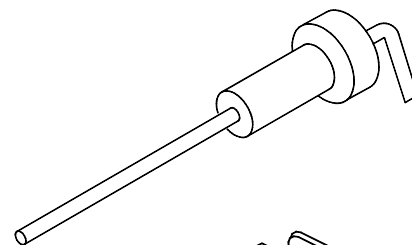

3) POWER SAFETY RELAY TEST (Located inside top cabin)

Turn power switch **on** from touchpad. Measure Voltage across Input to Coil, between terminals 1 & 2. Should read approx. 9V to 10V D.C.

Measure Voltage across Output, between terminals "COM" to Ground. Should read 120V.

Measure Voltage across Input, between terminals "NO" to Ground. Should read 120V.

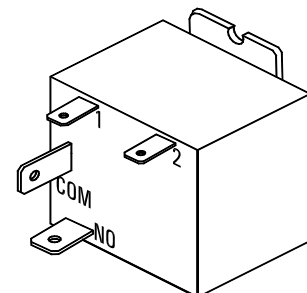

4) HEATER SAFETY RELAY TEST (Located inside top cabin)

Make sure power switch in back of unit is on (toggle up).

Turn power switch **on** (energize) from touchpad. Measure Input Voltage across coil, between terminals 0 & 1. Should read 120V.

Measure Output Voltage across Heater Element. Should read 220 V. If there is no Voltage across the Heating Element, measure Output Voltage between terminals 4 & 8.

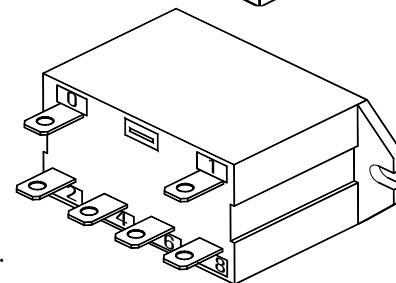

Turn power switch **off** from touchpad. The Voltage should be a constant 220V even when not energized.

Turn power switch **on** from touchpad. Measure Voltage across terminals 2 & 6. Should read 220V.

If 120V was applied to relay coil and it does not energize, replace relay.

5) CHECK DISPENSE VALVES FOR LIME BUILD-UP (Located inside top cabin)

Drain The Water Tank To Just Below The Level Of The Dispense Valves.

Remove The Valves And Clean. You Can Take These Valves Apart By Hand As Shown.

Replace The Assembly As Needed.

Replace The Valve Into The Tank And Refill tank.

- The **SINGLE DISPENSE VALVE** is factory adjusted to dispense **0.5 oz./sec.** of water during the brew cycle (spray duration).
- The **DOUBLE/ DILUTION DISPENSE VALVE** is factory adjusted, on **both sides**, to dispense **0.22 oz./sec** of water during **dilution** cycle.

TO ADJUST WATER FLOW RATE:

Locate adjustment screw on valve (as show here).

Using an Allen Key or a flat screwdriver, rotate ¼ turn at a time,

Clockwise (CW) to decrease water flow rate or

Counter-Clockwise (CCW) to increase water flow rate.

Check water flow output after each ¼ turn.

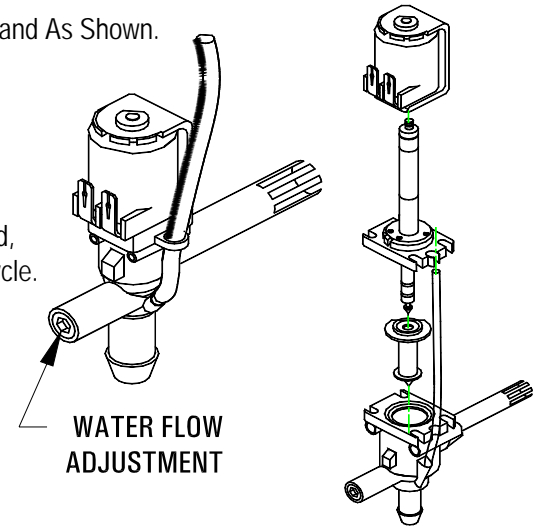

CLEANING AND SANITIZING

SANITIZING:

All food dispensing units should be sanitized periodically. All parts to be sanitized must be cleaned first.

To prepare a sanitizing solution:

ADD 2 TSP. OF LIQUID CLOROX BLEACH (5.25% CONCENTRATION) TO 1 GALLON OF WATER AT ROOM TEMPERATURE (70°-90°F).

Note: Always start with a unopened bottle of Clorox Bleach since the solution from an opened bottle has a short life span.

- Soak all parts for a minimum of 3 min. in the sanitizing solution.
- Let all sanitized parts drain and dry naturally. **DO NOT WIPE THEM DRY.**
- Before using the sanitized unit (or parts) with food stuffs, rinse all parts thoroughly with water.

Water pipe connecting and fixtures directly connected to a potable water supply shall be sized, installed, and maintained in accordance with Federal, State, and Local codes (section 7).

CLEANING:

1. Empty contents from brew funnel, wash and let dry (use a mild dishwasher detergent).
2. To wipe all surfaces of the machine, turn the power switch to OFF first, then wipe surfaces, then turn power back ON.

BC302-IT FRONT VIEW



BC2-IT OPEN FRONT VIEW

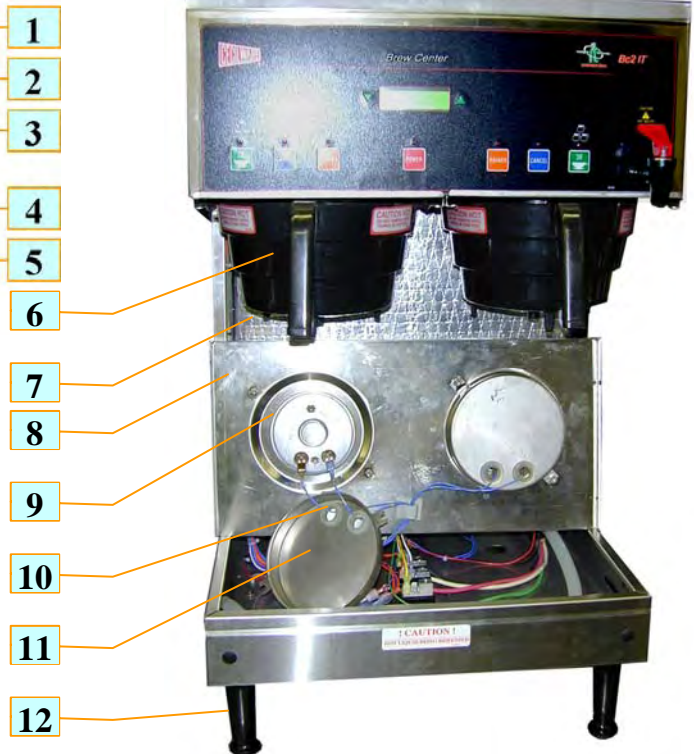

PARTS IDENTIFICATION

ITEM	BC301-IT		BC2-IT BC302-IT		DESCRIPTION
	P/N	QTY	P/N	QTY	
1	SF26A	1	SB49A	1	Cabinet Top Cover
2	----	--	---	--	Touch Pad Label:
	NG35A	1	NG39A	1	BC1-IT /BC2-IT
	NG37A	1	NG40A	1	BC301-IT / BC302-IT
			NG36A	1	BC120-IT
3	DO42A	1	D042A	2	Faucet, Hot Water
4	SF28A	1	SB66A	1	Front Cover
5	SF27A	1	SB65Q	1	Cabinet Frame Ass'y
6	V210Q	1	V210Q	2	Funnel Ass'y, Black Stainless Steel - Optional
7	SF74Q	1	SC81Q	1	Tank Weldment Ass'y
8	R615A	1	SC86A	1	Base Warmer Cover
9	G108A	1	G108A	2	Warmer Element
10	M090A	2	M090A	4	Grommet F/Heat Shield
11	U485A	1	U485A	2	Heat Shield
12	M172S	1	M172S	1	Legs [Set of 4]
13	L069A	1	L069A	1	Power Switch (located at top or bottom)
14	K331A	1	K331A	1	Elbow Fitting, In. Valve
15	C396Q	1	C396Q	1	Fuse Holder Ass'y
16	CE202	1	CE202	1	Power Cord 30A - Optional

BC2-IT, BC302-IT BACK VIEW

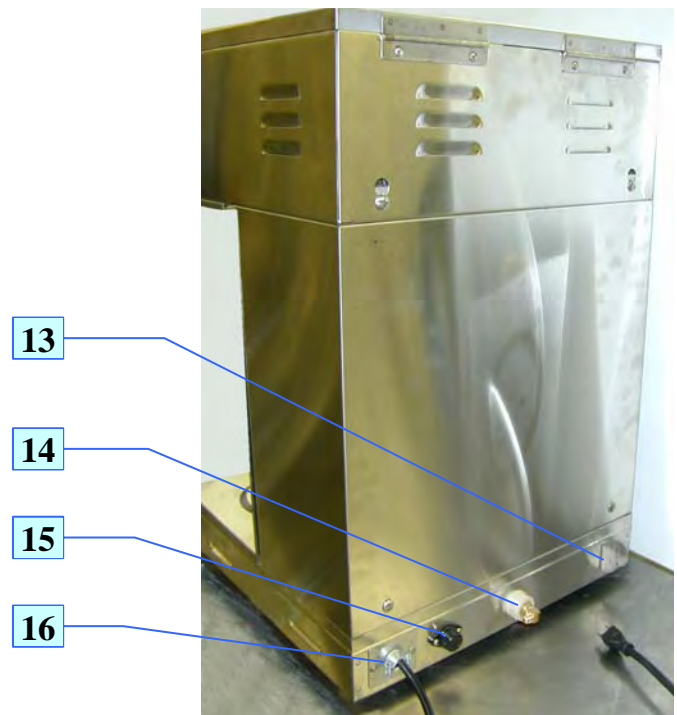

TOP CABIN OPEN VIEW BC302-IT

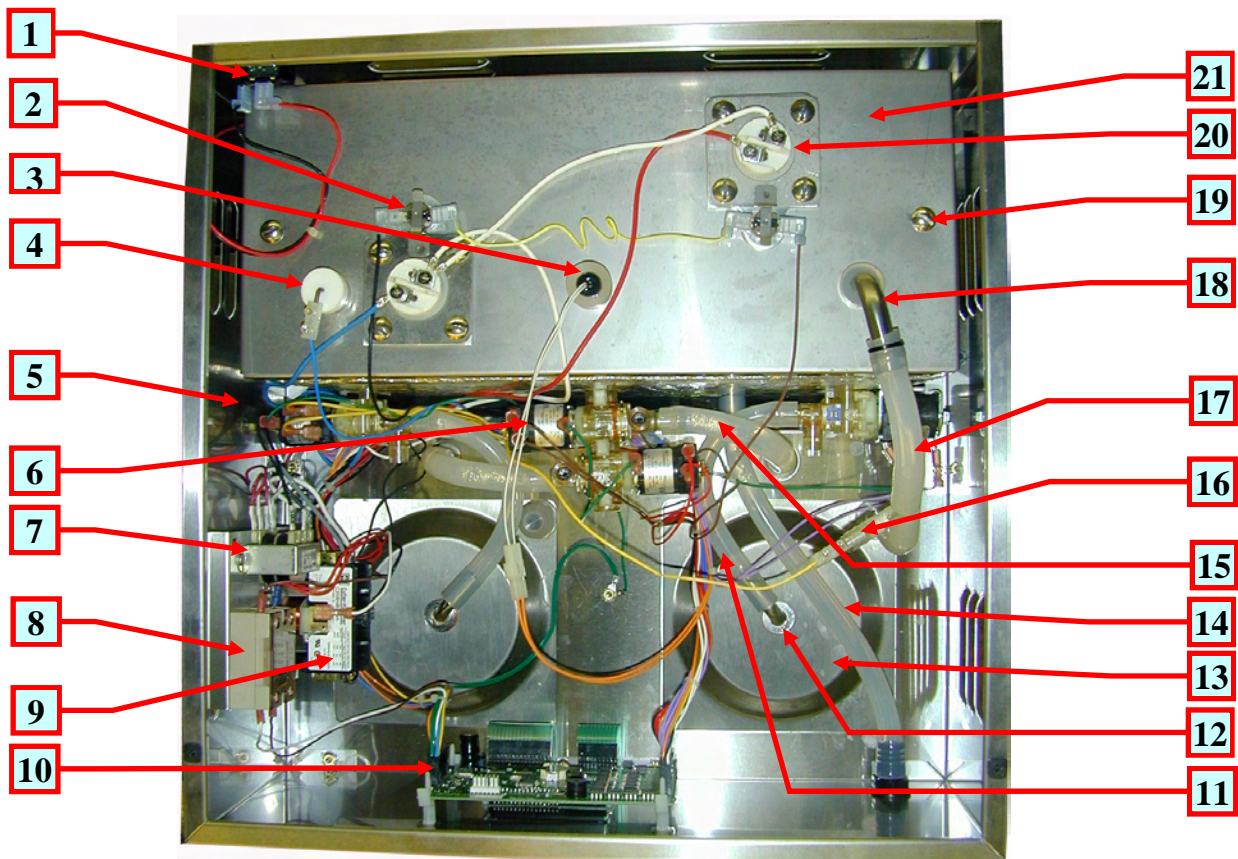

TOP CABIN - PARTS IDENTIFICATION

ITEM	P/N BC301-IT	QTY	P/N BC2-IT BC302-IT	QTY	DESCRIPTION
1	L069A	1	L069A	1	POWER SWITCH
2	L656A	1	L656A	2	HI-LIMIT
3	L639A	1	L639A	1	THERMISTER PROBE
4	K402Q	1	K402Q	1	WATER LEVEL CONTROL PROBE (WAS K355Q)
5	L688B	1	L688B	2	DINSPENSE VALVE, SINGLE WITH BLK MEMBRANE x202A
6	L689A	1	L689A	1	DINSPENSE VALVE, DUAL, BYPASS
7	CH87A	1	CH87A	1	TRANSFORMER
8	L553A	1	L553A	1	RELAY, 120V, 25A (HEATER SAFETY) [USED IN 240V UNITS ONLY]
9	B203A	1	B203A	1	RELAY, 110V, 15A (POWER SAFETY)
10	L669A	1	L669A	1	MAIN CONTROL BOARD (IT)
11	M483A	1	M483A	2	SILICONE HOSE (.312"ID x 7"L)
12	K671Q	1	K671Q	2	SPRAY HEAD FITTING ASS'Y WITH
	M197A	1	M197A	2	RUBER WASHER
13	SD06Q	1	SD06Q	2	SPRAY HEAD BASE ASS'Y
	E107A	1	E107A	2	SPRAY HEAD
	K668A	1	K668A	2	NUT
14	M483A	1	M483A	1	SILICONE HOSE (.312"ID x 11"L)
15	M483A	1	M483A	2	SILICONE HOSE (.312"ID x 6"L)
16	K683A	1	K683A	1	SAFETY OVERFLOW FTB
17	M483A	1	M483A	1	SILICONE HOSE (.312"ID x 10.5"L)
18	K525A	1	K525A	1	S.S ELBOW TUBE
19	P465A	1	P465A	1	SCREW, ¼-20 x 5/8
20	G402A	1	-----		HEATER (1.7 KW 120V) OR
	-----	1	G369A	2	HEATER (3.0 KW 230V)
	G286A				HEATER (4.0 KW 230V)
21	RK70A	1	SC82A	1	TANK TOP

TOP CABIN OPEN VIEW BC301-IT

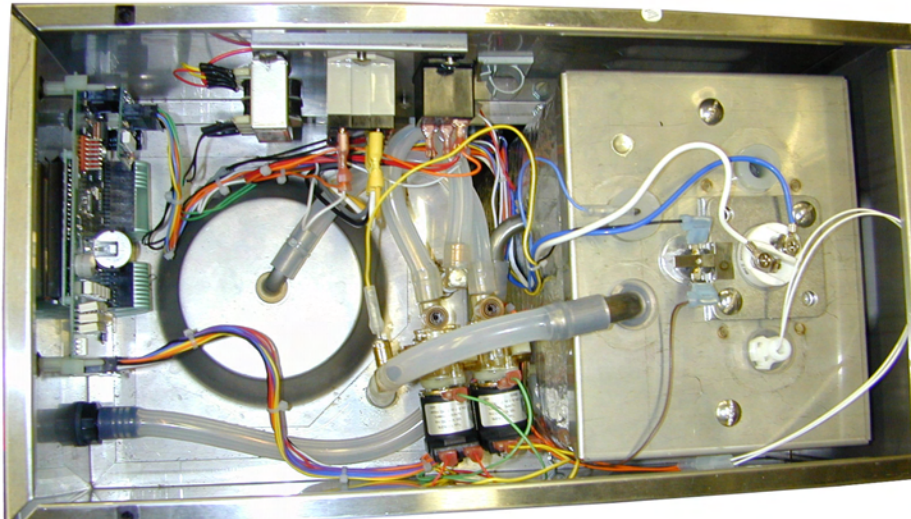

BOTTOM CABIN OPEN VIEW

BC301-IT

BC2-IT, BC302-IT

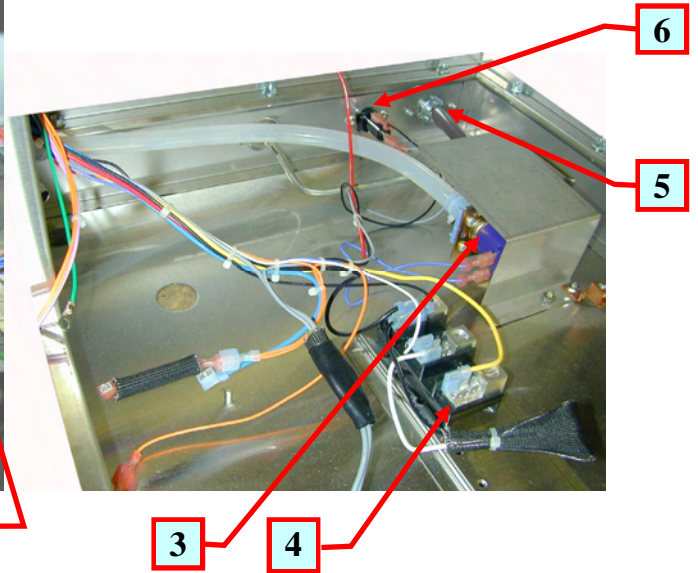
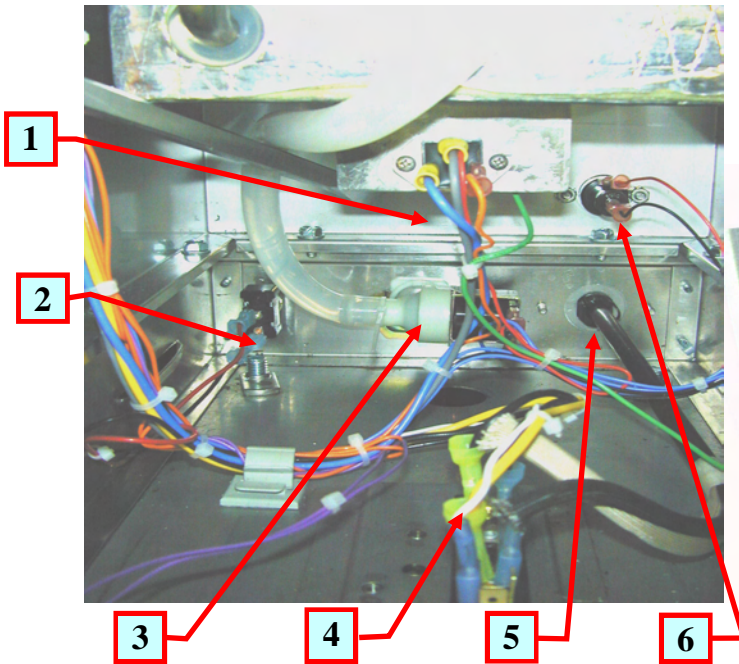

OTTOM CABIN - PARTS IDENTIFICATION

ITEM	P/N BC301-IT	QTY	P/N BC2-IT BC302-IT	QTY	DESCRIPTION
1	L623A	1	L623A	2	TRIAC, 40 Amps
2	LO69A	1	LO69A	1	POWER SWITCH (located in the back at bottom or at the top)
3	CD257	1	CD257	1	WATER INLET VALVE (mounted on back panel or inside bottom compartment)
4	B083A	1	B083A	1	TERMINAL BLOCK
5	CE202	1	CE202	1	POWER CORD
6	C396Q	1	C396Q	1	FUSE HOLDER ASS'Y

CARRIER ASS'Y

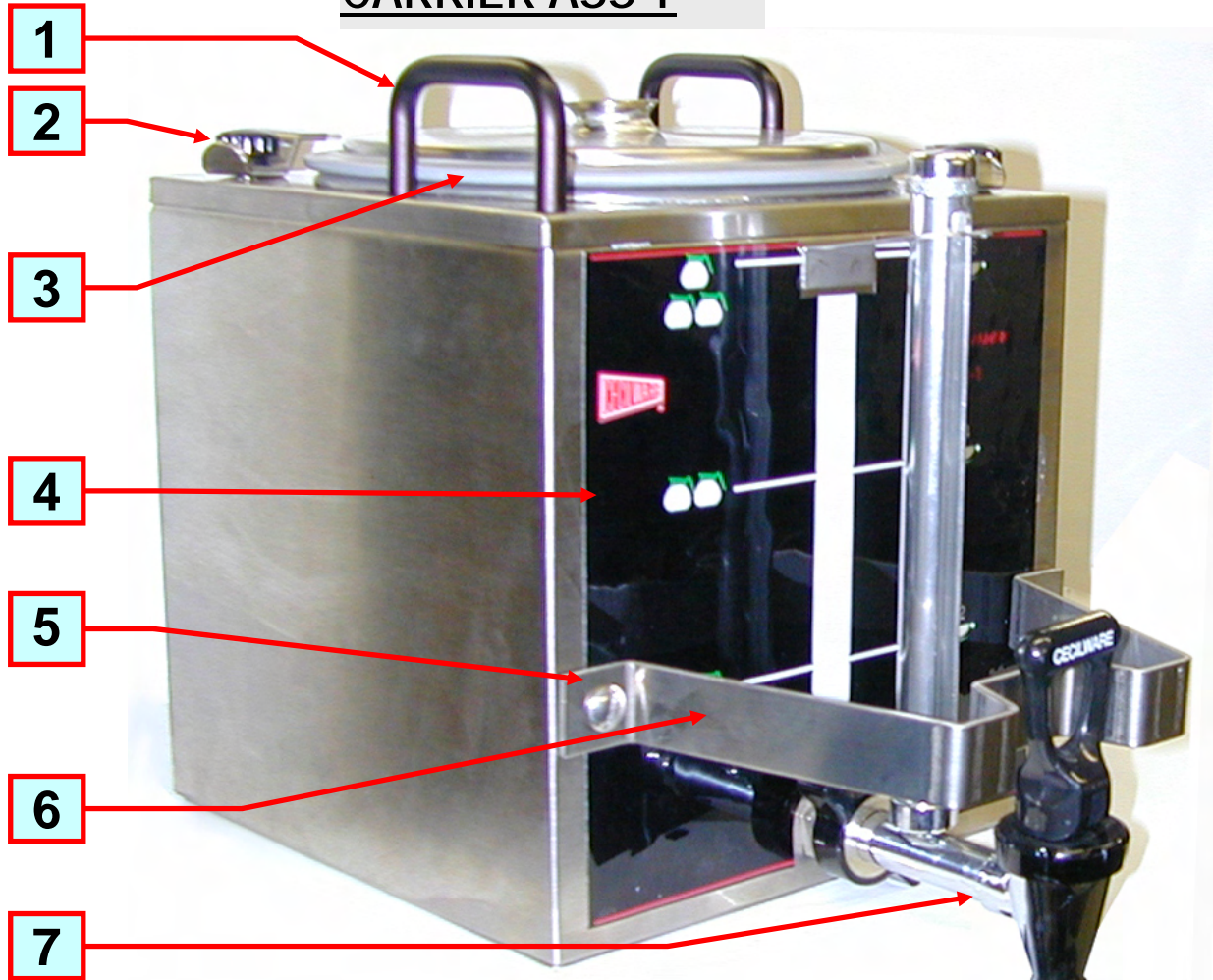

CARRIER ASS'Y 97208

[* RECOMMENDED SPARE PARTS]

Item		Description	Part #
1	*	Handle, black 3"	02015
2	*	Hold Down Bracket	U833A
2	*	Thumb Screw	M299A
3	*	Carrier Cover S.S.	U811A
	*	Gasket, Cover Carrier	M294A
4		Label	NG47A
5		Screw	P808A
6	*	Faucet Guard	U812A
7	*	Faucet & Shank Ass'y 8"	99461
8	*	Faucet Washer	7227
9	*	Faucet Hex Nut	03067
10	*	Washer, Base	38318
11	*	Sight Gauge Shield	38316
12	*	Sight Gauge Glass	38315
13	*	Washer, End Cap	38317
14	*	End Cap	38314

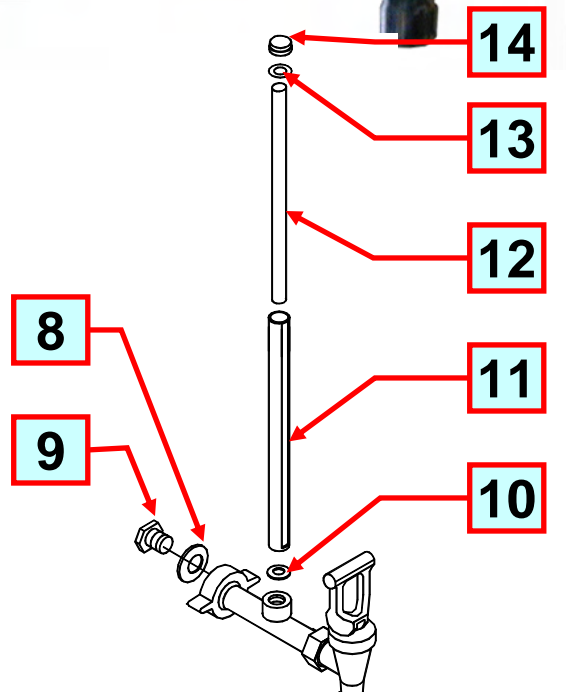

FAUCET & SHANK ASS'Y 99461

FRONT VIEW-BC301-IT



BACK VIEW- BC2-IT, BC302-IT



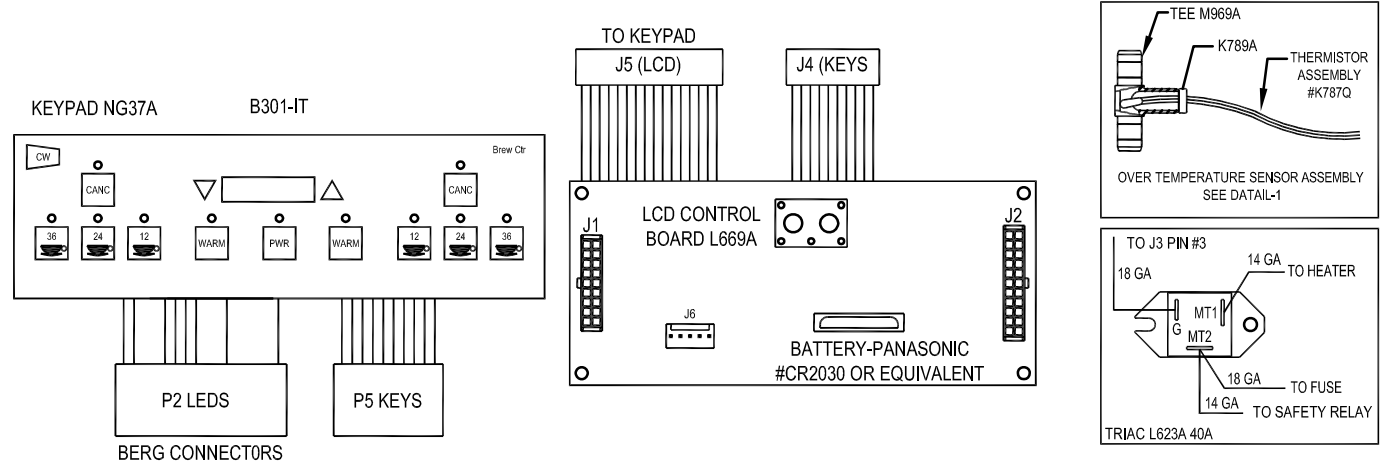
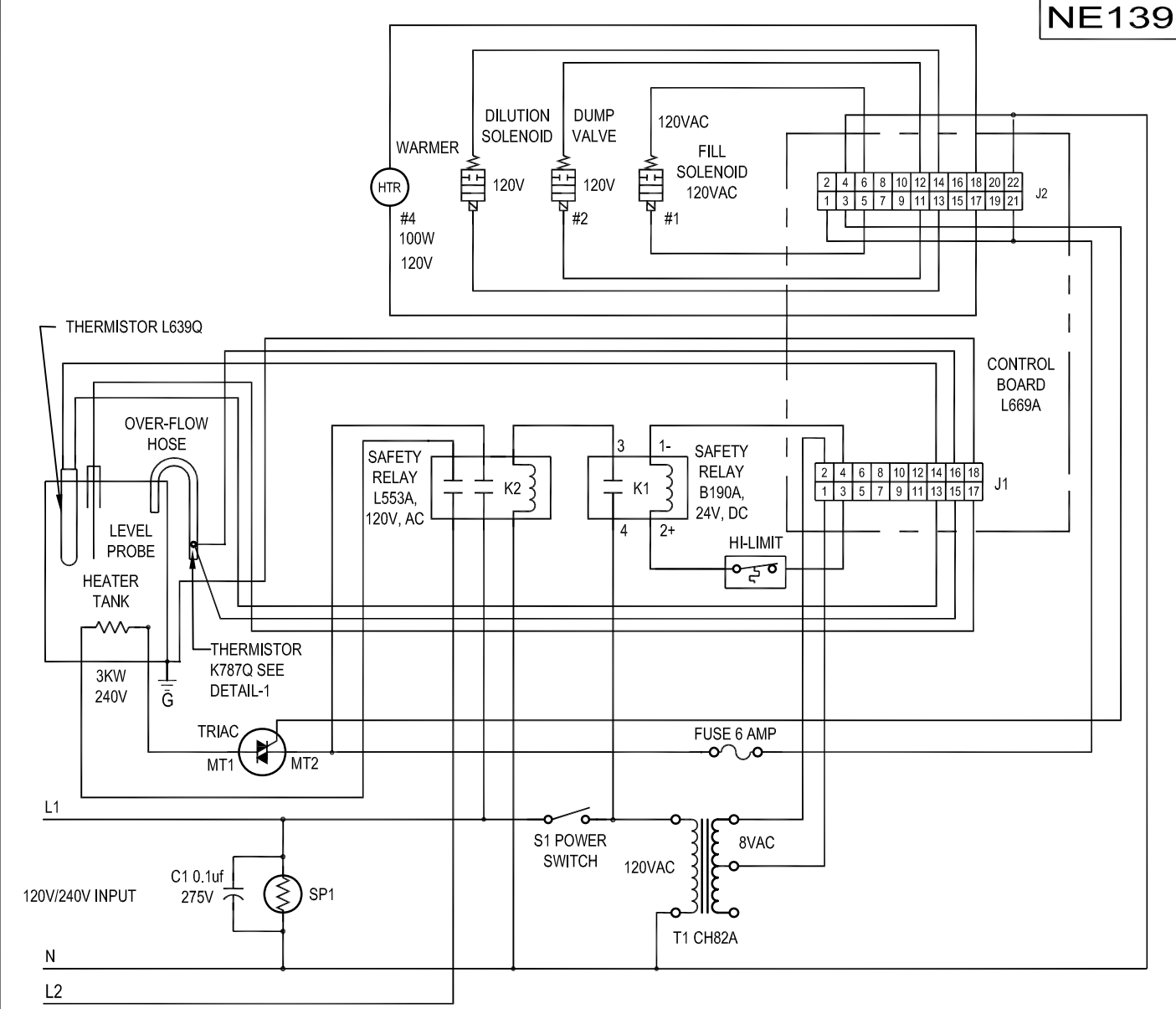

REV	BY	DATE	DESCRIPTION	APP'D BY	DATE	PART NO	NE139
				CG	12/10/2000	SCALE	
<p>CECILWARE CORPORATION 43-05 20 AVE. L.I.C. NY 11105</p>							<p style="writing-mode: vertical-rl; transform: rotate(180deg);">NE139</p>
<p>TITLE: ELECTRICAL DIAGRAM BC301-IT 120/240V, 3KW, 1 PH</p>						<p>REV. C</p>	

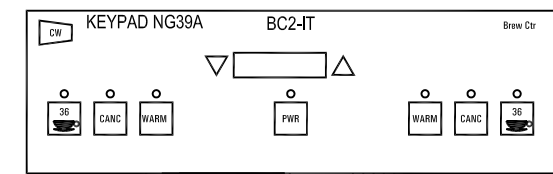
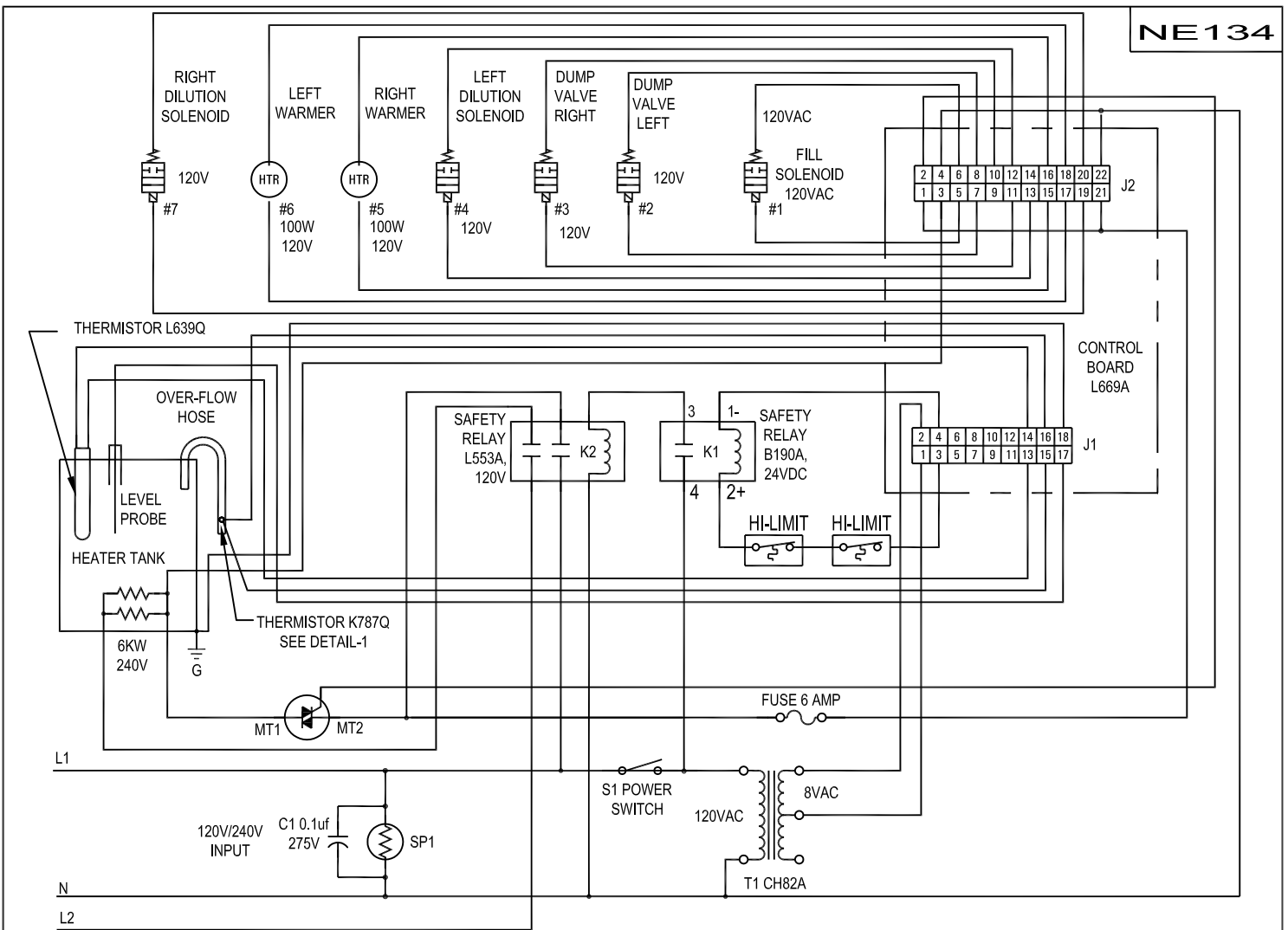

BERG CONNECTORS

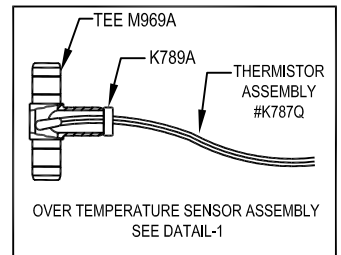
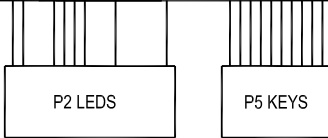

OVER TEMPERATURE SENSOR ASSEMBLY SEE DATAL-1

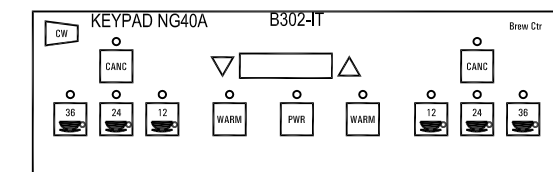

BERG CONNECTORS

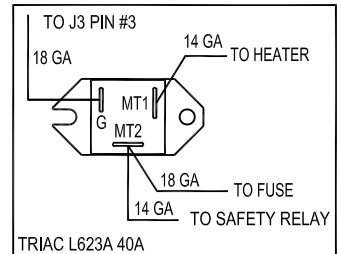
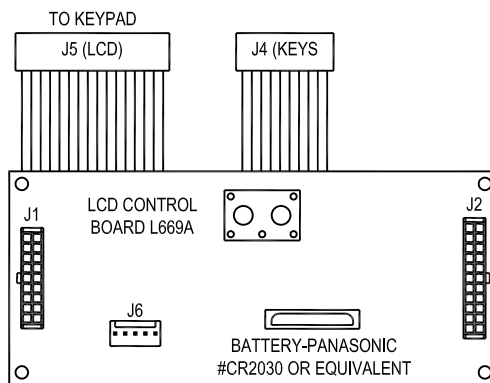
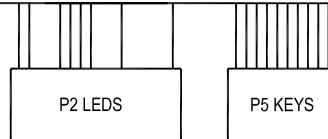

TRIAC L623A 40A

REV	BY	DATE	DESCRIPTION	APP'D BY	DATE	PART NO	NE139
				DRAWN BY	MM	DATE	12/10/2000
						SCALE	
<p>CECILWARE CORPORATION 43-05 20 AVE. L.I.C. NY 11105</p>							
TITLE: ELECTRICAL DIAGRAM BC2-IT, BC302-IT 120/240V (BEFORE 2008)							REV. C

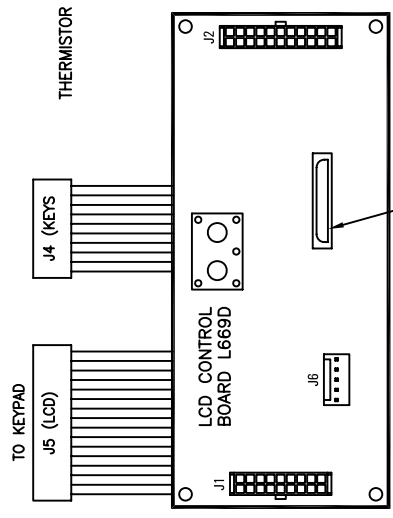
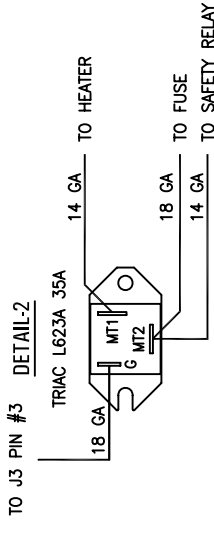
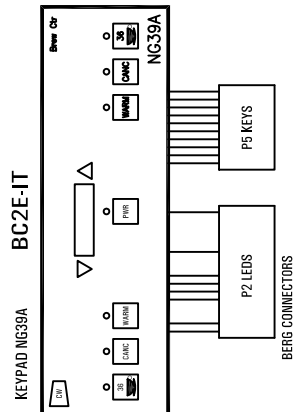
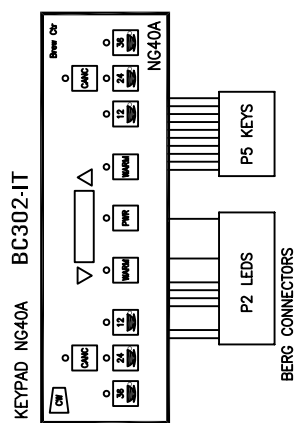
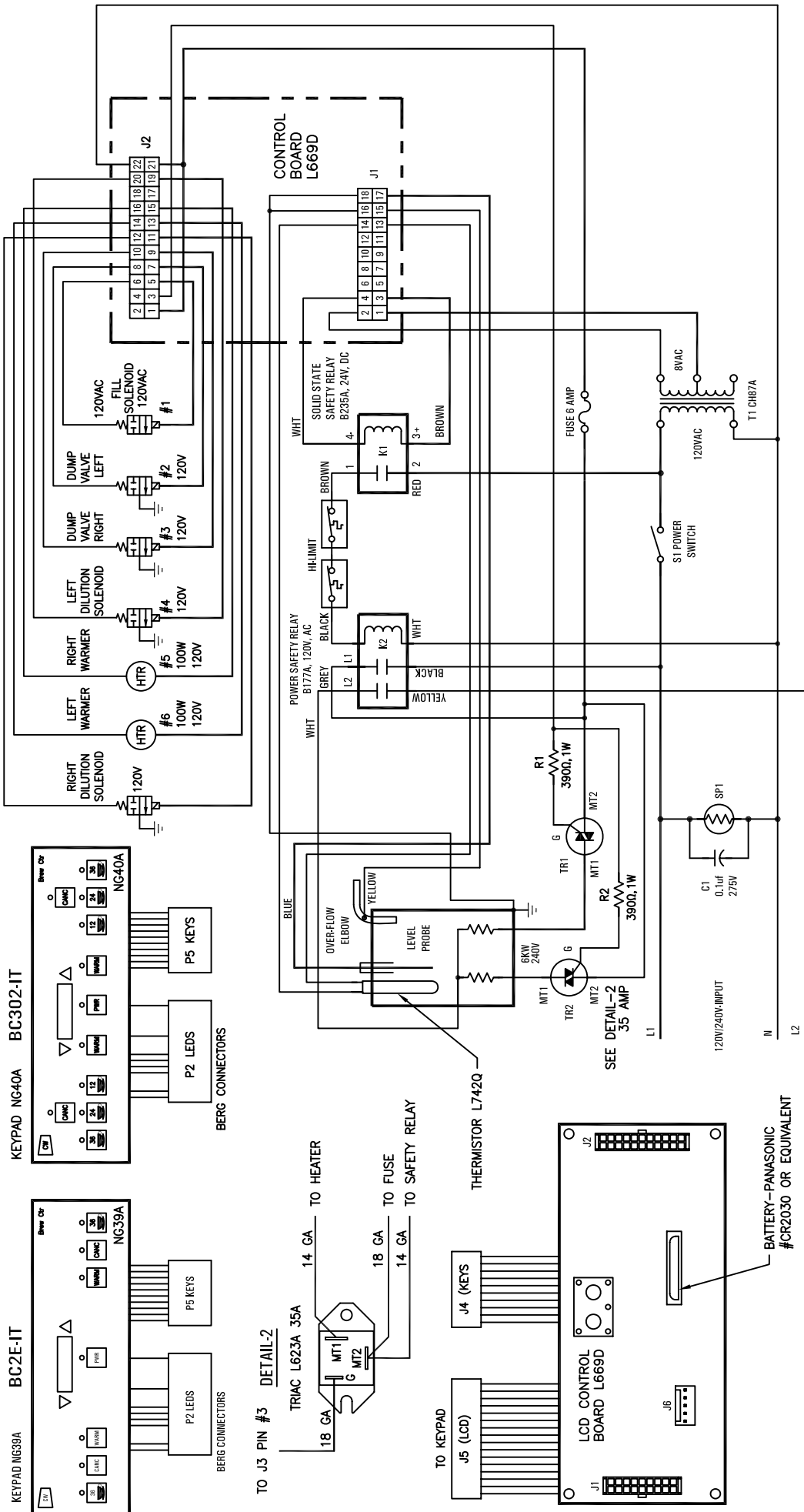

REV	BY	DATE	DESCRIPTION
C		02/01/10	THERMISTOR L742Q WAS L6390, OVER FLOW ELBOW WAS HOSE
B		04/02/09	CHANGED RELAY CONNECTION NUMBERS
A		7/5/06	RELAY WAS B1906, 24V, DC, MOVED HLLIMIT SWITCH

TOLERANCES UNLESS OTHERWISE SPECIFIED	FINISHED DECIMAL DIMENSIONS	FRACTIONAL DIMENSIONS	ANGULAR MATERIAL
DO NOT SCALE THIS DRAWING	±.005	±.1/64	±.1/2°

DATE	APPROVED BY	DATE	SCALE
5/4/2010			

TITLE ELECTRICAL DIAGRAM - 120V/240V 6KW 1PH (BC2E-IT/BC302-IT) DRAWING NO. NE251 REV. C

120/240V