

Belt Drive Tube Axial Duct Fans

BTA, WTA & HTA SERIES

Designed for duct connected applications such as paint booth exhaust, air make-up fans, general exhaust, etc.



FEATURES

BTA - FOR CLEAN, DRY AIR WITH A MAXIMUM TEMPERATURE OF 200°F (95°C)

- Adjustable motor base.
- Heavy duty pillow block ball bearings with high temperature grease.
- Extended lube lines with external grease fittings.
- TEFC motors are standard.
- Cast aluminum blades up to 48"; fans 54" & 60" have polypropylene reinforced fiberglass blades.
- Airfoil shaped belt tube for improved efficiency; motor, belts, drives and bearings are isolated from air stream.

WTA - FOR MOISTURE LADEN AIR WITH A MAXIMUM TEMPERATURE OF 200°F (95°C)

- Heavy duty pillow block bearings with moisture displacement collars + stainless steel shaft.

HTA - FOR CLEAN, DRY AIR WITH A MAXIMUM TEMPERATURE OF 375°F (190°C)

- Paint color is beige on these models, high temperature bearings and grease.



Paint color on HTA models is beige.

BTA, WTA & HTA SERIES

Belt Direct Tube Axial Duct Fans

OPTIONS & ACCESSORIES

For a complete listing of all available options and accessories available for this fan and ordering guidelines, see Tube Axial Duct Fan Options & Accessories page.

When ordering, replace "T" in the model name shown in the specifications table with ALL letters of the options and accessories required, as shown on the Tube Axial Duct Fan Options page.

Options must be requested at time of order, as they cannot be added later.

Non-stock, made-to-order products are non-returnable and cannot be cancelled.
To order WTA or HTA models, replace "BTA" with "WTA" or "HTA" in the specifications table.

DIMENSIONS

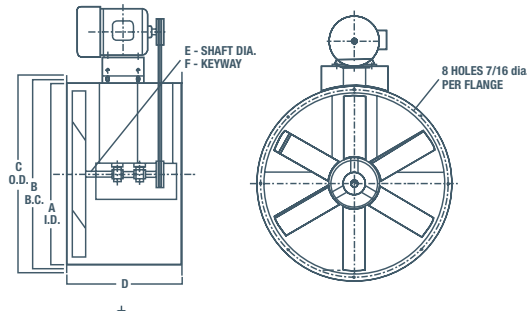

FAN SIZE	A	B	C	D	E	F	WEIGHT (lbs) without motor
12"	12"	14"	15 1/8"	17"	3/4"	3/16"	53
15"	15 3/8"	17"	18 3/8"	17"	3/4"	3/16"	62
18"	18 3/8"	20"	21 3/8"	21"	1"	1/4"	76
24"	24 3/8"	25 7/8"	27 3/8"	21"	1 3/16"	1/4"	132
30"	30 3/8"	32 3/8"	33 3/8"	21"	1 7/16"	3/8"	174
34"	34 3/8"	36 3/8"	37 3/8"	27"	1 7/16"	3/8"	225
36"	36 3/8"	38 3/8"	39 3/8"	27"	1 7/16"	3/8"	239
42"	42 3/8"	44 3/8"	45 3/8"	32"	1 7/16"	3/8"	326
48"	48 3/8"	50 3/8"	51 3/8"	32"	1 15/16"	1/2"	420
54"	54 3/8"	56 3/8"	57 3/8"	40"	1 15/16"	1/2"	552
60"	60 3/8"	62 3/8"	63 3/8"	40"	1 15/16"	1/2"	601

BLADE DIAMETER	CFM @ STATIC PRESSURE																																							
	MODEL #	RPM	HP	dBA @ 5 ft	0"				1/8"				1/4"				3/8"				1/2"				3/4"				1"				1 1/4"				1 1/2"			
					CFM	BHP	FEI	FE _{Pact} (kW)	CFM	BHP	FEI	FE _{Pact} (kW)	CFM	BHP	FEI	FE _{Pact} (kW)	CFM	BHP	FEI	FE _{Pact} (kW)	CFM	BHP	FEI	FE _{Pact} (kW)	CFM	BHP	FEI	FE _{Pact} (kW)	CFM	BHP	FEI	FE _{Pact} (kW)	CFM	BHP	FEI	FE _{Pact} (kW)	CFM	BHP	FEI	FE _{Pact} (kW)
12"	BTA12T30075A*	2535	3/4	60	1650	0.40	-	-	1494	0.40	-	-	1343	0.40	-	-	869	0.40	-	-	-	-	-	-	-	-	-	-	-	-	-	-	-	-	-	-	-	-		
	BTA12T30075B*	2865	3/4	64	1862	0.58	-	-	1729	0.58	-	-	1582	0.57	-	-	1345	0.57	-	-	952	0.58	-	-	-	-	-	-	-	-	-	-	-	-	-	-	-	-		
	BTA12T30075*	3290	3/4+	70	2138	0.87	-	-	2025	0.87	-	-	1896	0.87	-	-	1773	0.87	-	-	1541	0.87	-	-	-	-	-	-	-	-	-	-	-	-	-	-	-	-	-	
15"	BTA15T30075A*	1850	3/4	61	2548	0.28	-	-	2357	0.31	-	-	2114	0.31	-	-	-	-	-	-	-	-	-	-	-	-	-	-	-	-	-	-	-	-	-	-	-	-		
	BTA15T30075B*	2105	3/4	66	2903	0.41	-	-	2739	0.44	-	-	2540	0.46	-	-	2282	0.46	-	-	1415	0.45	-	-	-	-	-	-	-	-	-	-	-	-	-	-	-	-	-	
	BTA15T30075*	2405	3/4	72	3324	0.61	-	-	3179	0.65	-	-	3016	0.68	-	-	2814	0.68	-	-	2560	0.68	-	-	-	-	-	-	-	-	-	-	-	-	-	-	-	-	-	
18"	BTA18T30075A*	1556	3/4	58	4110	-	-	-	3930	-	-	-	3760	-	-	-	3540	-	-	-	3260	-	-	-	1760	-	-	-	-	-	-	-	-	-	-	-	-	-	-	
	BTA18T30075B*	1785	3/4	61	4680	-	-	-	4530	-	-	-	4380	-	-	-	4210	-	-	-	4020	-	-	-	3440	-	-	-	-	-	-	-	-	-	-	-	-	-	-	
	BTA18T30100*	1920	1	63	4161	0.73	1.07	0.71	3994	0.76	1.12	0.74	3734	0.78	1.13	0.76	3411	0.78	1.13	0.76	2765	0.73	1.06	0.71	1629	0.84	0.70	0.81	1115	0.98	0.53	0.94	-	-	-	-	-	-	-	
24"	BTA24T30150*	2255	1 1/2	68	4884	1.19	0.89	1.13	4740	1.22	0.94	1.16	4552	1.25	0.96	1.18	4346	1.27	0.99	1.20	4036	1.27	0.98	1.20	2882	1.20	0.84	1.14	1994	1.34	0.63	1.26	1470	1.50	0.50	1.41	-	-	-	-
	BTA24T30200*	2510	2	72	5441	1.63	0.80	1.53	5313	1.66	0.85	1.56	5151	1.71	0.87	1.60	4969	1.74	0.89	1.60	4754	1.76	0.89	1.65	4099	1.69	0.90	1.58	2968	1.69	0.73	1.58	2226	1.84	0.59	1.72	-	-	-	-
	BTA24T30075*	1180	3/4	58	6750	-	-	-	6325	-	-	-	5880	-	-	-	5360	-	-	-	4700	-	-	-	2180	-	-	-	-	-	-	-	-	-	-	-	-	-	-	
30"	BTA30T30150*	1475	1 1/2	64	6973	0.85	1.37	0.83	6625	0.91	1.39	0.88	6152	0.96	1.37	0.93	5692	0.99	1.37	0.95	5043	1.03	1.28	0.99	3262	1.05	0.99	1.01	1596	1.21	0.56	1.15	-	-	-	-	-	-	-	
	BTA30T30200*	1620	2	67	7657	1.13	1.22	1.10	7321	1.19	1.25	1.15	6942	1.25	1.26	1.20	6531	1.28	1.27	1.23	6026	1.33	1.23	1.27	4741	1.38	1.10	1.31	2883	1.42	0.78	1.35	1652	1.64	0.50	1.54	-	-	-	-
	BTA30T30300*	1890	3	72	8936	1.80	1.08	1.65	8650	1.87	1.11	1.70	8335	1.93	1.14	1.75	8003	1.99	1.15	1.80	7627	2.04	1.16	1.85	6755	2.14	1.12	1.93	5581	2.19	1.03	1.97	4074	2.20	0.85	1.98	2484	2.40	0.56	2.15
36"	BTA36T30100*	965	1	58	10040	0.73	2.09	0.71	9228	0.81	1.97	0.79	8118	0.87	1.81	0.84	6413	0.85	1.61	0.82	2963	0.88	0.85	0.85	-	-	-	-	-	-	-	-	-	-	-	-	-	-		
	BTA36T30150*	1095	1 1/2	61	11401	1.07	1.80	1.03	10758	1.17	1.76	1.11	9812	1.24	1.67	1.18	8772	1.28	1.58	1.21	5974	1.17	1.25	1.11	2590	1.43	0.59	1.35	-	-	-	-	-	-	-	-	-	-		
	BTA36T30300*	1380	3	64	14368	2.14	1.47	1.93	13859	2.26	1.48	2.03	13207	2.38	1.45	2.14	12553	2.48	1.42	2.22	11720	2.55	1.38	2.28	9072	2.48	1.22	2.22	4249	2.59	0.63	2.32	-	-	-	-	-	-	-	
42"	BTA42T30200*	1635	5	73	17004	3.55	1.28	3.14	16604	3.71	1.30	3.28	16092	3.85	1.29	3.51	15587	3.98	1.29	3.51	14986	4.08	1.28	3.60	13538	4.26	1.22	3.76	11797	4.28	1.16	3.78	7221	4.04	0.80	3.57	4664	4.45	0.53	3.93
	BTA42T30300*	1910	2	63	15963	1.59	1.65	1.50	14667	1.66	1.61	1.56	13215	1.71	1.56	1.60	11619	1.72	1.49	1.61	6448	1.58	0.96	1.49	-	-	-	-	-	-	-	-	-	-	-	-	-	-		
	BTA42T30150*	1245	5	71	21797	4.04	1.25	3.57	20909	4.16	1.26	3.67	19928	4.26	1.26	3.76	18909	4.34	1.25	3.83	17799	4.39	1.24	3.88	15337	4.37	1.20	3.86	7728	4.17	0.69	3.68	-	-	-	-	-	-	-	
48"	BTA48T30200*	1425	7 1/2	75	24920	6.07	1.14	5.20	24184	6.19	1.16	5.30	23342	6.32	1.17	5.41	22510	6.42	1.17	5.50	21517	6.49	1.17	5.56	19603	6.62	1.16	5.67	17359	6.55	1.14	5.61	9926	6.09	-	-	-	-	-	
	BTA48T30300*	1770	2	60	20355	1.55	2.01	1.46	18518	1.67	1.91	1.57	16460	1.75	1.80	1.64	13937	1.75	1.67	1.64	6625	1.63	0.94	1.53	-	-	-	-	-	-	-	-	-	-	-	-	-	-		
	BTA48T30150*	1005	5	67	26521	3.44	1.57	3.04	25236	3.61	1.56	3.19	23633	3.75	1.52	3.31	22152	3.88	1.48	3.42	20399	3.92	1.45	3.46	14476	3.65	1.23	3.22	-	-	-	-	-	-	-	-	-	-		
54"	BTA54T30200*	1205	7 1/2	72	31901	5.92	1.38	5.07	30764	6.13	1.38	5.25	29581	6.33	1.37	5.42	28298	6.49	1.36	5.56	26965	6.63	1.34	5.68	23978	6.77	1.30	5.81	19659	6.55	1.20	5.61	9465	6.36	0.64	5.45	-	-	-	-
	BTA54T30300*	1335	10	75	34336	8.29	1.16	7.08	34336	8.29	1.28	7.08	33163	8.48	1.28	7.25	32120	8.65	1.28	7.39	31016	8.89	1.27	7.60	28318	9.11	1.24	7.79	25650	9.22	1.22	7.89	21450	8.89	1.13	7.60	-	-	-	-
	BTA54T30150*	670	3	63	29487	2.55	1.99	2.28	27685	2.74	1.94	2.45	24670	2.88	1.78	2.57	21127	2.93	1.62	2.62	9969	2.75	0.85	2.46	-	-	-	-	-	-	-	-	-	-	-	-	-			
60"	BTA60T30200*	900	7 1/2	71	39588	6.17	1.54	5.28	38376	6.44	1.55	5.52	36741	6.71	1.52	5.75	34802	6.91	1.49	5.93	32129	7.04	1.41	6.04	25944	7.03	1.25	6.04	11119	6.89	0.59	5.91	-	-	-	-	-	-		
	BTA60T30300*	990	10	73	43627	8.26	1.42	7.06	42434	8.54	1.43	7.30	41056	8.83	1.43	7.55	39487	9.03	1.42	7.72	37361	9.26	1.37	7.92	32438	9.45	1.27	8.09	18303	8.52	0.80	7.28	10359	9.54	0.46	8.17	-	-	-	-
	BTA60T31500*	1130	15	76	49758	12.31	1.30	10.40	48797	12.64	1.32	10.70	47594	12.91	1.33	10.90	46282	13.20	1.33	11.20	44877	13.47	1.32	11.40	41032	13.91	1.26	11.80	36521	14.06	1.18	11.90	30198	13.69	1.06	11.60	14336	13.55	0.52	11.50
60"	BTA60T30500*	710	5	69	39490	-	-	-	37130	-	-	-	34510	-	-	-	31680	-	-	-	28260	-	-	-	-	-	-	-	-	-	-	-	-	-	-	-	-	-		
	BTA54T30750*	810	7 1/2	72	45020	-	-	-	42890	-	-	-	40760	-	-	-	38660	-	-	-	35890	-	-	-	29810	-	-	-	20380	-	-	-	-	-	-	-	-			
	BTA54T31000*	905	10	75	50330	-	-	-	48450	-	-	-	46590	-	-	-	44640	-	-	-	42420	-	-	-	37520	-	-	-	31620	-	-	-	22910	-	-	-	15230	-	-	
60"	BTA54T31500*	1025	15	78	57010	-	-	-	55520	-	-	-	53850	-	-	-	52110	-	-	-	50170	-	-	-	46260	-	-	-	42140	-	-	-	36610	-						

Options & Accessories For Tube Axial Duct Fans

When ordering, replace "T" in the Model Number (in the Performance Specification Chart) with ALL accessory code as shown on this page.

Options must be requested at time of order, as they cannot be added later.
Non-stock, made-to-order products are non-returnable and cannot be cancelled.



DISCONNECT SWITCH

Accessory Code: **A**

See page K4 in Controls & Thermostats section for more information.

Ships loose.

Available as an accessory ordered separately.



INLET GUARDS OUTLET GUARD

Accessory Code:

B Inlet | J Outlet

Spiral plated OSHA guard. Fits intake or exhaust. Can be used in conjunction with companion ring.

To order installed, add letter to part number.

Also available as an accessory ordered separately.



CR - COMPANION RING

Accessory Code: **C**

1/4" plate angle ring. Used to attach guards or ducts to tube axial fans.

To order installed, add letter to part number.

Also available as an accessory ordered separately.

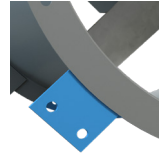

SCV - VERTICAL SUPPORT CLIPS

Accessory Code: **D**

1/4" plate horizontal support clips.

Bolts to the vertical support clips welded to the fan. Two clips per end. Must be used with vertical clips (D).

Must be requested at time of order.

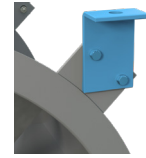

SCH - HORIZONTAL SUPPORT CLIP

Option Code: **K**

Heavy duty support legs welded to the fan.

Suitable for floor-mount tube axial fans. 4" standard; 16" available (consult factory).

Sold in pairs.

Must be requested at time of order.

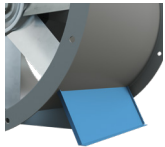

SPL - SUPPORT LEGS

Accessory Code: **E**

Heavy duty support legs welded to the fan. Suitable for floor-mount tube axial fans.

4" standard; 16" available (consult factory).

Sold in pairs. Must be requested at time of order.



MCVR - MOTOR & BELT COVER

Accessory Code: **F**

8-gauge galvanized steel. Acts as both motor and belt cover.

3/4" expanded-metal screen allows motor heat escape. Bolts to motor mount.

For HTA/BTA/WTA fans only. To order installed, add letter to part number.

Also available separately.



BLG - BELT GUARD

Accessory Code: **G**

Protects belts and drives. 18-gauge galvanized steel.

For HTA/BTA/WTA fans only. Not required if using Motor Cover (F).

To order installed, add letter to part number.

Also available separately.

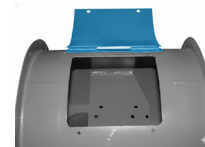

ID - INSPECTION DOOR

Accessory Code: **H**

10" x 12" hinged and bolted door.

Air-dry finish.

Can be installed in a location specified by customer.

Must be requested at time of order.

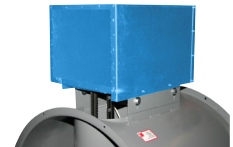

WC - WEATHER COVER

Accessory Code: **L**

18-gauge galvanized steel. Acts as both motor and belt cover.

Fully enclosed for weather protection.

Bolts to motor mount.

For HTA/BTA/WTA fans only. To order installed, add letter to part number.

Also available separately.

SPECIALS

Accessory Code: **I**

Explosion-proof motors

Steel fan blades

Optional coating

Must be requested at time of order.

ORDERING EXAMPLES



EX 1) If ordering a BTA18T10050 with support legs (E) and an inspection door (H), use E & H here: **BTA18EH10050**.

EX 2) If ordering a BTA18T10050 with horizontal clips & belt guard, use **BTA18DKG10050**.

WIRED JUNCTION BOX

Option Code: **W**

Wired junction box using BX cable.

For BTA models only.

Must be requested at time of order.

ACCESSORIES			OPTIONS INSTALLED WELDED TO TUBE				ACCESSORIES		
FAN SIZE	COMPANION RING	GUARD	HORIZONTAL CLIP	SUPPORT LEG	VERTICAL CLIP	INSPECTION DOOR	BTA SIZE	WEATHER COVER	MOTOR COVER
12"	CR12P	MC12G	SCH12-60 (Must order vertical clip accessory)	SPL12	SCV12-60	ID12	12" - 18"	MCVR1-WP	MCVR1
15"	CR15P	MC15G		SPL15		ID15	24" - 30"	MCVR2-WP	MCVR2
18"	CR18P	MC18G		SPL18		ID18	34" - 36"	MCVR3-WP	MCVR3
20"	CR20P	MC20G		SPL20		ID20	42" - 48"	MCVR4-WP	MCVR4
24"	CR24P	MC24G		SPL24		ID24	54" - 60"	MCVR5-WP	MCVR5
30"	CR30P	MC30G		SPL30		ID30			
34"	CR34P	MC34G		SPL34		ID34			
36"	CR36P	MC36G		SPL36		ID36			
42"	CR42P	MC42G		SPL42		ID42			
48"	CR48P	MC48G		SPL48		ID48			
54"	CR54P	MC54G		SPL54		ID54			
60"	CR60P	MC60G		SPL60		ID60			
							ACCESSORIES		
							FRAME SIZE	BELT GUARD	
							48 - 145T	BLGD1	
							182T - 184T	BLGD2	
							213T - 256T	BLGD3	
							284 AND UP	BLGD4	