

Forward Curved Roof Exhausters

300 SERIES



FEATURES

- Square base allows discharge to be oriented in any of 4 directions.
- Back draft damper and bird screen included.
- Heavy duty ball bearings suitable for -65° to +250° F.
- Cabinet insulated with 1/2" fiberglass insulation.
- Automatic gravity back draft damper and bird screen are included.
- Low operating RPM of forward curved blowers results in low noise levels.
- Quiet operation. Blower is mounted on heavy steel angle with rubber isolators.
- Grey baked powder coat finish.
- Motor receives the cooling benefits of being in the air stream for increased motor life.
- Recessed base ensures weather proof mounting to curb.



**AVAILABLE WITH MOTORS &
DRIVES FACTORY INSTALLED**
Consult Delair Software for details



Easy to service. Blower, motor and drives accessible through the convenient removable top.



300 SERIES Forward Curved Roof Exhausters

PERFORMANCE SPECIFICATIONS

TYPICAL MAXIMUM CFM @ SP																						
MODEL	1/2" SP				1" SP				1 1/2" SP				2" SP				2 1/2" SP				Min HP	Max HP
	CFM	BHP	FEI	FEPact (kW)	CFM	BHP	FEI	FEPact (kW)	CFM	BHP	FEI	FEPact (kW)	CFM	BHP	FEI	FEPact (kW)	CFM	BHP	FEI	FEPact (kW)		
307	1200	0.73	0.52	0.74	1100	0.71	0.73	0.72	900	0.66	0.89	0.67	700	0.69	0.88	0.70	500	0.73	0.81	0.74	1/4	3/4
309	1800	0.71	0.72	0.72	1600	0.75	0.92	0.76	1300	0.71	1.08	0.72	1000	0.73	1.07	0.74	700	0.73	0.99	0.74	1/4	3/4
310	2800	1.44	0.54	1.37	2500	1.43	0.73	1.36	2200	1.41	0.88	1.34	2000	1.5	0.95	1.42	1600	1.5	0.94	1.42	1/4	1 1/2
312	3700	1.88	0.53	1.74	3300	1.94	0.70	1.80	2900	1.92	0.83	1.78	2500	1.93	0.91	1.79	1700	1.94	0.78	1.80	1/4	2
315	5700	2.98	0.50	2.68	5200	2.99	0.69	2.69	4600	2.9	0.84	2.61	4100	2.94	0.94	2.65	3400	2.97	0.94	2.67	1/2	3
318	8800	4.9	0.46	4.29	8100	4.96	0.63	4.34	7300	4.88	0.78	4.27	6700	4.92	0.90	4.31	5900	4.93	0.95	4.32	1/2	5

CFM values listed are summarized for convenience. For full performance data refer to our Delair program. Power rating (BHP) does not include transmission losses. Performance certified is for installation type B: Free inlet, Ducted outlet. Performance ratings do not include the effect of appurtenances (accessories).

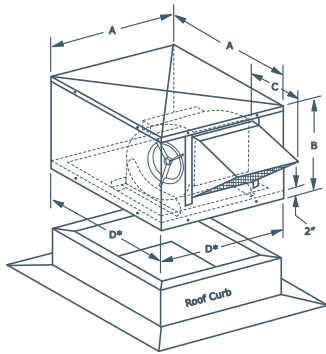

D is an inside dimension. Curb size must be smaller to allow for flashing.

DIMENSIONS

*D is an inside dimension. Curb size must be smaller to allow for flashing.						
MODEL	A	B	C	* D INSIDE	SHAFT DIAMETER	WEIGHT (lbs) without motor
307	20 3/8"	16 5/8"	9"	20"	3/4"	45
309	24 3/8"	19 3/8"	10 5/8"	24"	3/4"	63
310	28 3/8"	21 3/8"	11 3/8"	28"	3/4"	88
312	32 3/8"	24 5/8"	13 1/8"	32"	3/4"	113
315	36 3/8"	28 3/8"	14 7/8"	36"	1"	156
318	40 3/8"	33 3/4"	17 3/8"	40"	1"	224

BACK DRAFT DAMPER RESISTANCE CALCULATION

To estimate back draft damper resistance, use the following formula:

$$S.P. = \frac{CFM^2 \times DAMPER FACTOR}{1,000,000}$$

Example

Example Model 315, 1500 CFM

$$S.P. = \frac{1500 \times 1500 \times 0.052}{1,000,000} = 0.117 \text{ in. w.g.}$$

MODEL	DAMPER FACTOR
307	1.520
309	0.469
310	0.175
312	0.167
315	0.052
318	0.033



SCAN TO VIEW FEI CHARTS



SCAN TO USE DELAIR SOFTWARE



Canarm certifies that the 300 Series shown herein are licensed to bear the AMCA Seal. The ratings shown are based on tests and procedures performed in accordance with AMCA Publication 211 and AMCA Publication 311 and comply with the requirements of the AMCA Certified Ratings Programme.

The AMCA certified ratings seal applies to air and sound performance only. The 300 Series shown herein are not approved by AMCA for FEI ratings. May 2026