



Innovative Foodservice Equipment Custom
Designed for Performance, Service and Value.

**INSTALLATION AND OPERATING
INSTRUCTIONS**

Cinnabon™ Proofing Cabinet

PICA70-32-AED

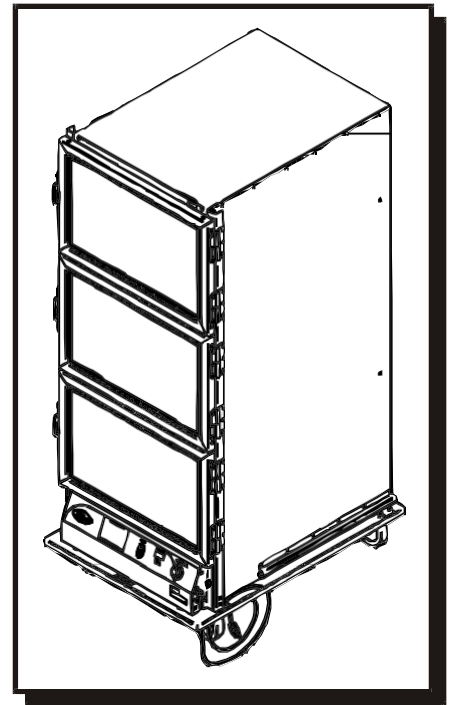

**INTENDED FOR OTHER THAN HOUSEHOLD USE
RETAIN THIS MANUAL FOR FUTURE REFERENCE
UNIT MUST BE KEPT CLEAR OF COMBUSTIBLES AT ALL TIMES**



FOR YOUR SAFETY

Do not store or use gasoline or other flammable vapors and liquids in the vicinity of this or any other appliance.



WARNING

Improper installation, adjustment, alteration, service or maintenance can cause property damage, injury or death. Read the Installation, Operating and Maintenance Instructions thoroughly before installing or servicing this equipment.



This equipment has been engineered to provide you with year round dependable service when used according to the instructions in this manual and standard commercial kitchen practices.



Toll Free: (844) 265-0250

P/N 780086 3/06

Fax: (800) 548-9392

Website: www.BevLes.com

E-mail: sales@BevLes.com

BevLes
1525 East Lake Rd
Erie, Pa 16511

The **BevLes Company** takes pride in the design and quality of our products. When used as intended and with proper care and maintenance, you will experience years of reliable operation from this equipment. To ensure best results, it is important that you read and follow the instructions in this manual carefully.

Installation and start-up should be performed by a qualified installer who thoroughly read, understands and follows these instruction.

If you have questions concerning the installation, operation, maintenance or service of this product, write Technical Service Department BevLes Company, Inc., 1525 east Lake Rd. Erie, PA 16511

TABLE OF CONTENTS

ITEM	PAGE
Safety Precautions_____	1
General Information_____	2
Unpacking Instructions_____	3
Setting-Up_____	3
Operation_____	4
Operating Tips_____	5
Safety And Health_____	5
Maintenance_____	5
Trouble Shooting_____	6
Parts Replacement_____	7
Wiring Diagram 120v_____	8
Wiring Diagram 208/230v_____	9
Parts List_____	10
Notes_____	11
Warranty_____	12

SAFETY PRECAUTIONS

Before installing and operating this equipment be sure everyone involved in its operation is fully trained and aware of all precautions. Accidents and problems can result by a failure to follow fundamental rules and precautions.

The following words and symbols, found in this manual, alert you to hazards to the operator, service personnel or the equipment. The words are defined as follows:



DANGER: This symbol warns of imminent hazard which may result in serious injury or death.



WARNING: This symbol refers to a potential hazard or unsafe practice, which could result in serious injury or death.



CAUTION: This symbol refers to a potential hazard or unsafe practice, which may result in minor or moderate injury or product or property damage.



NOTICE: This symbol refers to information that needs special attention or must be fully understood even though not dangerous.

THIS MANUAL SHOULD BE RETAINED FOR FUTURE REFERENCE

GENERAL INFORMATION



NOTICE: This product is intended for commercial use only. Not for household use.



CAUTION: These models are designed, built, and sold for commercial use. If these models are positioned so the general public can use the equipment make sure that cautions, warnings, and operating instructions are clearly posted near each unit so that anyone using the equipment will use it correctly and not injure themselves or harm the equipment.



WARNING: Check the data plate on this unit before installation. Connect the unit only to the voltage and frequency listed on the data plate. Connect only to 1 phase as listed on the data plate.



WARNING: Install per the spacing requirements listed in the installation section of this manual. We strongly recommend having a competent professional install the equipment. A licensed electrician should make the electrical connections and connect power to the unit. Local codes should always be used when connecting these units to electrical power. In the absence of local codes, use the latest version of the National Electrical Code.



WARNING: This device should be safely and adequately grounded in accordance with local codes, or in the absence of local codes, with the National Electrical code, ANSI/NFPA 70, latest edition to protect the user from electrical shock. It requires a grounded system and a dedicated circuit, protected by a fuse or circuit breaker of proper size and rating. Canadian installation must comply with the Canadian Electrical Code, CSAC22.2, as applicable.



NOTICE: Local codes regarding installation vary greatly from one area to another. The National Fire Protection Association, Inc. states in its NFPA96 latest edition that local codes are “Authority Having Jurisdiction” when it comes to requirement for installation of equipment. Therefore, installation should comply with all local codes.



DANGER: SHOCK HAZARD De-energize and lock-out all power to equipment before performing any maintenance, servicing or, cleaning of the equipment.



DANGER: SHOCK HAZARD Never clean any electrical unit by immersing it in water.



DANGER: SHOCK HAZARD- Operators should not open any panels that require the use of tools.

IMMEDIATELY INSPECT FOR SHIPPING DAMAGE

All containers should be examined for damage before and during unloading. The freight carrier has assumed responsibility for its safe transit and delivery. If equipment is received damaged, either apparent or concealed, a claim must be made with the delivering carrier.

A) Apparent damage or loss must be noted on the freight bill at the time of delivery. It must then be signed by the carrier representative (Driver). If this is not done, the carrier may refuse the claim. The carrier can supply the necessary forms.

B) If concealed damage or loss is not apparent until after equipment is uncrated, a request for inspection must be made to the carrier within 15 days. The carrier should arrange an inspection. Be certain to hold all contents and packaging material.

Installation and start-up should be performed by a qualified installer who has thoroughly read, understands and follows these instructions.

UNPACKING INSTRUCTIONS:

Note: All Bevi's cabinets are tested, inspected and expertly packed to insure arrival in a ready-to-use condition. If any damage or loss is discovered when unpacking, ask the carrier's agent (in writing) to inspect the product. This must be done within 15 days of delivery. You can then file a formal claim with the carrier. This product has been shipped securely packed on a wooden pallet, covered with a protective bag and corrugated shipping container and sealed with durable banding material. Carefully read the following unpacking instructions and properly dispose of all packaging materials.

To open:

1. Carefully cut and remove banding material.
2. Carefully lift the corrugated container off the product.
3. Open door(s) and remove the cartons containing the wire racks, pan supports, and all packing materials (tape, cardboard, etc.)
4. Carefully lift cabinet off pallet.
5. Check model number on the serial number label, located on the left side of the unit.
6. Release all wheel brakes

SETTING-UP

1. Remove all protective film from interior and, exterior surfaces on cabinet, and doors.
2. Place the cabinet in the location where it will be operated. When in position secure the brakes on the front two wheels. These brakes should always be locked when the cabinet is in use.
3. Install 1" NPT drain coupling, if needed (fig. 1) and connect drain line (by others) This will be used to drain the cast aluminum water pan.
4. Make certain that your unit is properly connected to the correct power source as specified on the serial number label, located on the side of the unit.
5. Insert a half size sheet pan 18" x 13" (not provided with proofer) in the slides under the base of the cabinet. This will serve as a condensation drip pan when cabinet is in use.
6. Open the cartons containing the pan supports and install all supports in cabinet. Starting from the bottom. Skip (2) slots between each support, to achieve a 4 1/2" spacing between racks.
7. Open the cartons containing the wire racks, and install racks in cabinet.

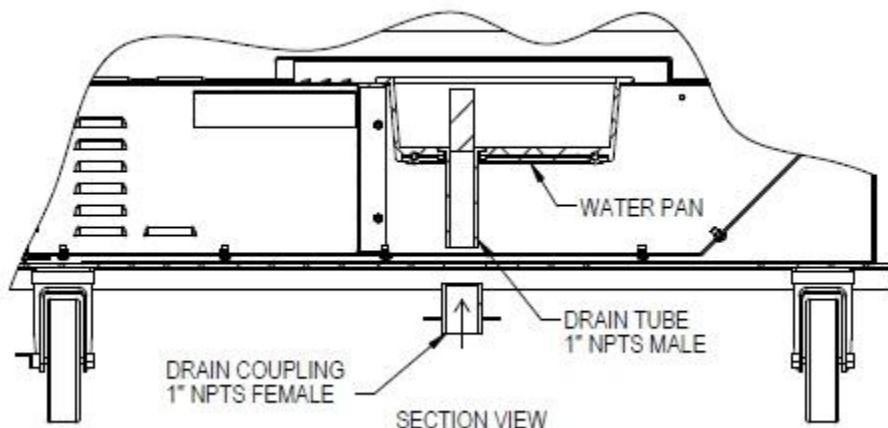

Fig. 1

OPERATION

1. Verify that wheel brakes are in locked position (front two casters).
2. Make sure stainless steel drain plug is in place in the cast aluminum water pan, and fill it 1/2 to 3/4 full
3. Make sure the polycarbonate water pan cover is properly in place with the holes over the pan.

for steps 4,5 and 6 see fig.2

4. Push the power switch to the "ON" Position. Always use this switch to turn the unit "ON" or "OFF".
5. Set the temperature control to the desired cabinet temperature. 90°F to 110°F is recommended as a starting position. Increase or decrease the cabinet temperature as needed to best suit your application.

To select desired cabinet temperature:

1. Press SET key under cabinet temperature display.
 2. Press INCREASE key or DECREASE key to adjust cabinet temperature.
 3. Press SET key to lock-in desired cabinet temperature. (If you don't press the SET key the temperature setting will revert back to previous setting).
6. Set the humidity control to the #3 or #4 position. This can be increased if necessary to suit your specific application.
 7. Make certain that the 18" x 13" sheet pan (not provided with proofer) that has been inserted in the slides on the bottom of the base is under the square hole to catch any condensation.
 8. Verify that the door(s) is closed and latched.
 9. Allow approximately 30-45 minutes for the cabinet to achieve the necessary temperature and humidity that you desire.
 10. The cabinet is now ready for product placement and the start of the proofing process.

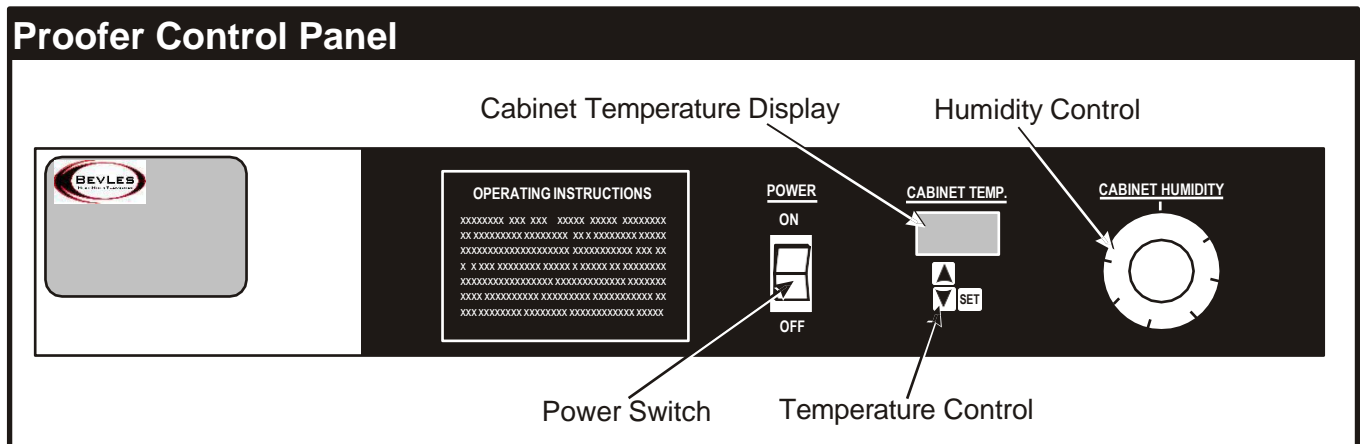

Fig.2

Note: Different products, or even different batches of the same product may require different cabinet temperatures and humidity settings. This may result in longer, or possibly even shorter proofing times.

OPERATING TIPS

Always inspect wheel brakes before attempting to move the cabinet. Make certain that brakes are in the locked position before placing cabinet into operation.

During "cold" start-up you may want to set the Humidity Control to the HI setting for 10 to 15 minutes to accelerate the humidity process. Remember to re-set the Humidity Control back to the desired setting before beginning the proofing process. Once the cabinet has been loaded with product and the proofing

process has started, the proofer door(s) should not be opened until proofing has been completed. The 18" x 13" sheet pan (not provided with proofer) that serves as a drip pan under the cabinet base should be checked, and if necessary, emptied at the end of each day.

The cabinet should be cleaned whenever necessary. It should be thoroughly cleaned at least once a week.

Note: It is recommended that humidity be kept at the minimum level that is practical for your operation. Excessive humidity with condensation on the walls and/or base of the cabinet is not considered desirable.

SAFETY AND HEALTH

BevLes Proofing Cabinets meet all cUL and NSF requirements. Always operate this proofer in accordance with the operating instructions found in this manual. Never remove the humidity-heating module without first disconnecting (unplugging) the unit from its power source. The cabinet is designed and built for easy cleaning. It should be cleaned frequently as described in the maintenance section.

MAINTENANCE

Cleaning: This cabinet was designed and built for maximum sanitation. It is not self cleaning, so it should be cleaned frequently with soap and water.

1. NEVER USE STEEL WOOL OR CAUSTIC CLEANING COMPOUNDS.
2. Make sure that the unit is turned OFF and **disconnected** from the electrical service.
3. Remove the polycarbonate water pan cover and side covers from the humidity-heating module.
4. Remove the pan supports and vertical uprights.
5. Remove the vent from the rear wall.
6. Clean inside of cabinet with soap and water. Clean polycarbonate water pan cover and door(s) with soft sponge, soap and water.
NEVER USE HARSH CLEANING SUBSTANCES OR ABRASIVES TO CLEAN POLYCARBONATE SURFACES, OR THE CAST ALUMINUM WATER PAN.
7. Remove and clean the 18" x 13" drip pan (not provided with proofer) from under the cabinet base.

If necessary, the humidity-heating module can be removed by, first disconnecting the external drain and removing the coupling,(fig.1). Then removing the two (2) black knobs (one located at each side on the module on the exterior of the cabinet). The module can be pulled out of the cabinet for additional cleaning. We suggest that you clean the water pan at least once a month with a solution of white vinegar and hot water. Allow white vinegar to remain in water pan overnight. Then use a soft cloth to wipe away any mineral buildup.

Important: When placing the humidity heating module back into the cabinet make certain that the module is pushed tightly against the cabinet and secured with the two (2) black knobs. Check to see that the one inch air flow opening at the rear of the humidity-heating module is behind the back vent that hangs on the rear wall of the cabinet. This is necessary to maintain uniform temperature and humidity distribution throughout the cabinet.

IF REPLACEMENT PARTS ARE EVER REQUIRED, ONLY USE PARTS THAT HAVE BEEN APPROVED BY BEVLES COMPANY, INC.

Should you require assistance, or service contact the BevLes service line at (844)265-0250 When you phone please have the model number and serial number of the proofer. This will assist our service technicians in providing you immediate assistance. You may want to briefly review the Troubleshooting Tips before you contact our factory.

TROUBLESHOOTING TIPS

No Power

If your proofer fails to start when the power is applied via power switch:

1. Check to see if the unit is properly connected to correct power source as specified on the serial number label.
2. Check to see that your power source (wall receptacle) has power - inspect circuit breaker.
3. Disconnect power cord and visually inspect for any damage.
4. Contact the BevLes Technical Service Department for assistance.

Excessive Humidity

If your proofer is producing excessive humidity:

1. Check the setting on the humidity control knob on the control panel, to see if it is set where you normally operate at.
2. Check the base of the cabinet to see if the excess humidity is draining through the drain hole in the center of the base.
3. Contact the BevLes Technical Service Department for assistance.

No Humidity

If your proofer is producing no humidity, or considerably less than normally achieved:

1. Inspect water level in the water pan.
2. Check the setting on the humidity control knob on the control panel, to see if it is set where you normally operate at.
3. Check to see if the cabinet door(s) are closed.
4. Make certain that the humidity-heating module's one inch air flow opening (at rear of module) is behind the cabinet back vent that hangs on the rear wall of the cabinet.
5. Make certain that the polycarbonate water pan cover is correctly positioned over the entire water pan and the louvers located in front of the water pan.
6. Verify that the fan blower is operating.
7. Contact the BevLes Technical Service Department for assistance.

Excessive Heat

If your proofer temperature is higher than normal:

1. Check the setting on the temperature control to see if it is set where you normally operate at.
2. Check the ambient room temperature to see if it is greater than your desired proofing temperature.
3. Contact the BevLes Technical Service Department for assistance.

No Heat

If your proofer is producing no heat, or considerably less than you normally achieve:

1. Check the setting on the temperature control to see if it is set where you normally operate at.
2. Check to see if the cabinet door(s) is completely closed.
3. Make certain that the humidity-heating module's one inch air-flow opening (at rear of module) is behind the cabinet back vent that hangs on the rear wall on the cabinet.
4. Verify that the fan blower is operating.
5. Contact the BevLes Technical Service Department for assistance.

Parts Replacement

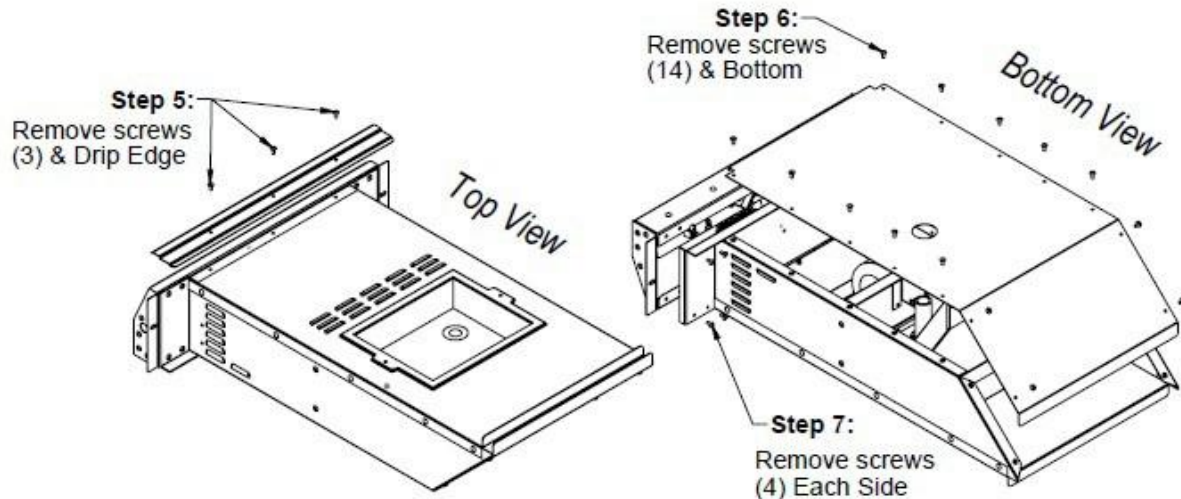

TO ACCESS ELECTRICAL COMPONENTS:

1. Make sure the unit is turned off and disconnected from electrical service.
2. Disconnect drain line and remove coupling (see fig. 1 page 4)
3. Remove the two black handled knobs (one located on each side of the control panel).
4. Pull the module out from the cabinet.

Refer to drawings above for steps 5, 6 and 7.

5. Remove screws(3) and stainless steel drip edge.
6. Turn module over, and remove screws from the bottom of the module. (7 screws each side). There will be (4) nylon caps and spacers, save and reuse.
7. Remove screws from the back side of control panel. (4 screws each side).
8. Carefully pull control panel forward.

After installing any new components, reverse the above steps. Make certain that the one inch air-flow opening at the back of the module is up behind the cabinet's back vent hanging on the rear wall.

Refer to wiring diagrams for additional information.

Amp rating: 120v Models

13 amps

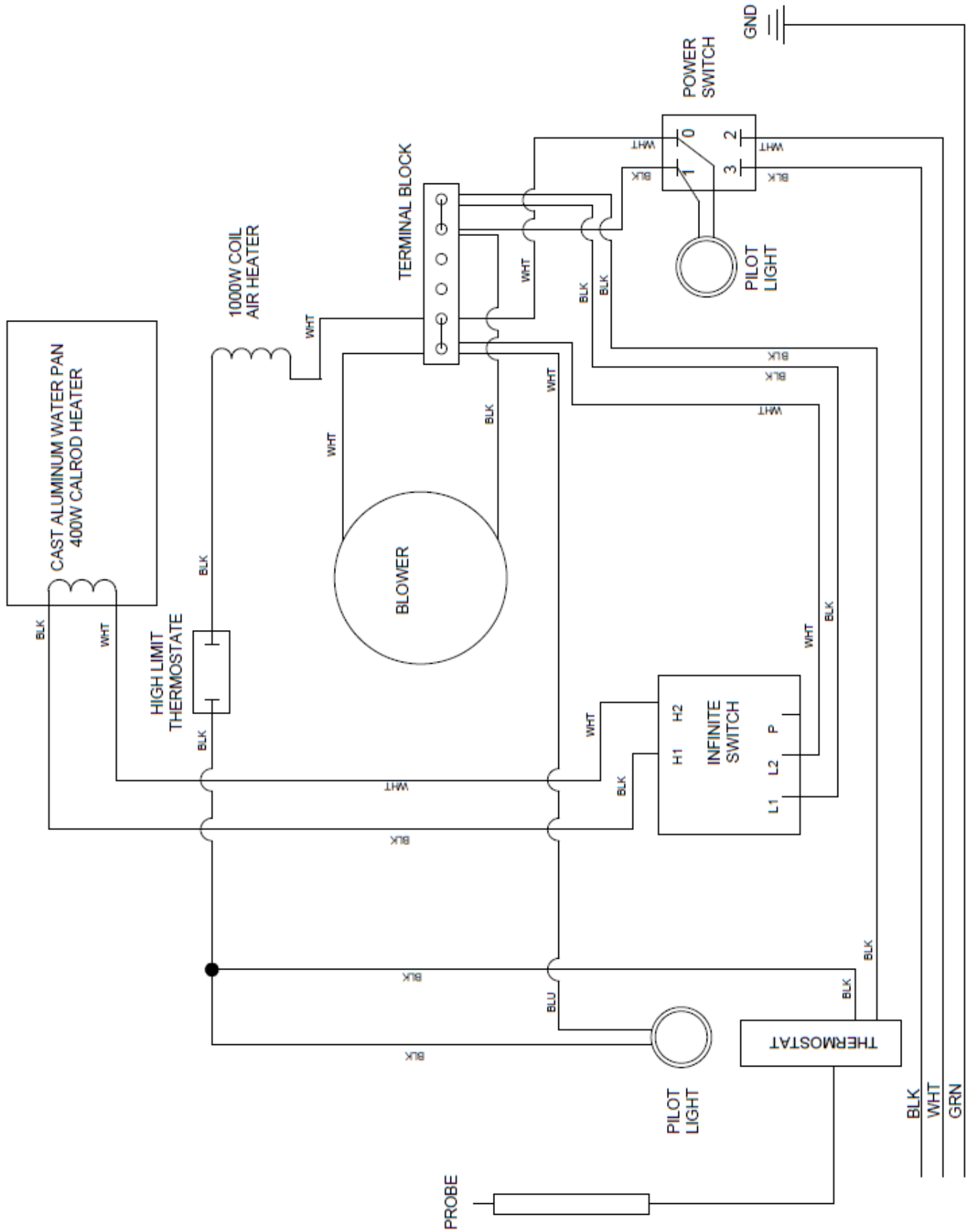

120/60-50/1

Replacement Parts Mechanical		
Part Number	Description	Qty.
720671	Pin Hinge	6
741874	Hinge, Cabinet Side	6
741875	Hinge, Door Side	6
750720	Pin, Latch	3
750419	Latch	3
781285	Latch Spring	3
750132	Latch, Butt	6
780036	Caster 5" Swivel w/Brake	2
780040	Caster 5" Swivel	2
783116	Knob Threaded 1/4-20 Bottom Module	2
784013	Wire Shelf	11
751121	Hanger, Slide Guide (Shelf/Pan Support)	22
740352	Back Vent Panel	1
751061	Retainer, Wiper Strip Extrusion	3
702520	Wiper Strip, White Silicone	3
742764	Side Cover, Heating Unit Aluminum	2
760040	Water Pan Cover, Polycarbonate	1
784124	Handle, Water Pan Cover	1
760055	Replacement Door Glass Polycarbonate, Clear	3
740223	Bracket, Mounting, Sensor	1
782092	Knob, Infinite Switch, Black	1
740348	Upright, 50.75" Long 1 1/2" Spacing	4
781295	Drain Brass	1
742745	Drain Coupling Weldment	1
781503	Drain Plug Stainless Steel	1
		1
Replacement Parts Electrical		
784448	Transformer, 120/240V	1
782204	Motor, Blower, & Housing 120V Proofer	1
782205	Motor, Blower & Housing, 240V Proofer	1
782088	Switch, Infinite, 120V/15A	1
782224	Switch, Infinite, 240V/15A	1
782226	Switch, Rocker, DPST, Black/Whi, 277V, 20A	1
1107200	Block Terminal, 6 Station 600V	1
782020	Heating Element Blower 1000W, 120V	1
784308	Heating Element Blower 1000W, 240V	1
782162	Relay, Solid State, 50A-240VAC	1
784737	Controller, Temperature Set 60-125 Deg. F	1



BEVLES COMPANY LIMITED WARRANTY

1525 East Lake Road • Erie, PA 16511

Phone: (844) 265-0250 Fax: (800) 548-9392

1. Bevles warrants to the original purchaser that on the date the equipment is shipped (sold), it will be free of defects in materials or workmanship. Bevles will, at its discretion, repair or replace, during the warranty period printed below, any part that has a defect in material or workmanship that was present when the product shipped from Bevles, and which manifests itself during the warranty period under normal use and service.

Parts: Two* years from date of original shipment from the Bevles factory.

Labor: One** year from date of original shipment from the Bevles factory.

* Air Circulation Blower Assemblies (motors) and Power Switches shall be one year from date of original shipment.

Calrod "Air" Heating Elements shall be three years from date of original shipment.

** All electrical components 120 days from date of original shipment.

2. Bevles must be contacted, and pre-approval must be issued by the Bevles factory prior to any type of service being performed. Bevles assumes no responsibility for any charges that were not expressly authorized by the Bevles factory, or for any charges that exceed, in Bevles' sole judgement, normal and customary amounts.
3. Bevles will pay UPS Ground charges for any part that has a defect in material or workmanship that was present when the product shipped from Bevles, and which manifests itself during the **first year** of the warranty period under normal use and service. All warranty replacement parts will ship F.O.B. Bevles factory, Erie, PA 16511.
4. This warranty shall be void in its entirety if any abuse of, misuse of, alteration/modification of or improper maintenance of original product occurs. If, at any time a claim is reported to Bevles, and the purchaser is delinquent in payment for the product, warranty will not apply.
5. Buyer's Remedies-If a Bevles product fails due to a defect in material or workmanship in conformity with the warranties in paragraph one, buyer shall notify Bevles of such failure within a reasonable time, but in no event beyond fifteen (15) days of such discovery of defect in material or workmanship. Bevles shall provide, in its sole discretion, either the repair or replacement of any defective or any non-conforming part. Bevles specifically disavows any other representation, warranty or liability relating to the continued use of the product.
6. Exclusion of consequential and incidental damages-In no event shall Bevles be liable for any incidental, special, indirect, or consequential damages, whether resulting from non-delivery or from the use, misuse, or inability to use the product, or from defects in the product, or from Bevles' own negligence or other tort. This exclusion applies regardless of whether such damages are sought for breach of warranty, breach of contract, negligence, or strict liability in tort or under any other legal theory.
7. Disclaimer of warranties-The warranties contained in paragraph one above are the exclusive warranties given by Bevles and supersede any prior, contrary, or additional representations, whether oral or written. Bevles hereby disclaims and excludes all other warranties-whether expressed, implied, or statutory-including any warranty of merchantability, any warranty of fitness for a particular purpose, and any implied warranties otherwise arising from course of dealing or usage of trade.

12/15



Toll Free: (844) 265-0250
Fax: (800) 548-9392
Website: www.BevLes.com
E-mail: sales@BevLes.com

BevLes
1525 East Lake Rd
Erie, Pa 16511