

Innovative Foodservice Equipment Custom
Designed for Performance, Service and Value.

INSTALLATION AND OPERATING INSTRUCTIONS

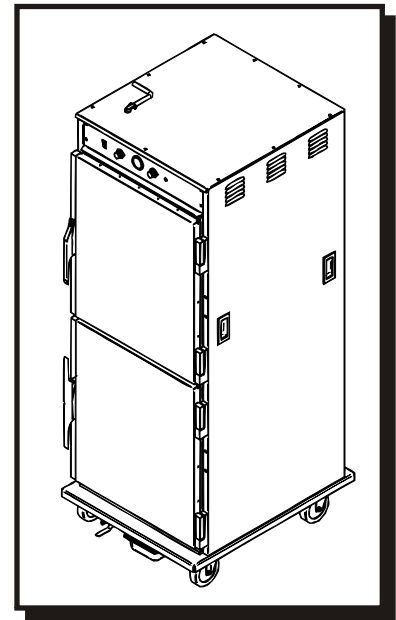

CLIMATE SELECT

HCSS74W12 (Full Size), HCSS44W6 (Half Size)
& HCSS34W5 (Under Counter Design)

**INTENDED FOR OTHER THAN HOUSEHOLD USE
RETAIN THIS MANUAL FOR FUTURE REFERENCE
UNIT MUST BE KEPT CLEAR OF COMBUSTIBLES AT ALL TIMES**



WARNING: For your safety do not store or use gasoline or other flammable vapors or liquids in the vicinity of this or any other appliance. Keep the area free and clear of combustibles. (See ANZI Z83.14B, 1991)



WARNING: Improper installation, adjustment, alteration, service or maintenance can cause property damage, injury or death. Read the Installation, Operating and Maintenance Instructions thoroughly before installing or servicing this equipment.



WARNING: Initial heating of unit may generate smoke or fumes and must be done in a well-ventilated area. Overexposure to smoke or fumes may cause nausea or dizziness.



This equipment has been engineered to provide you with year round dependable service when used according to the instructions in this manual and standard commercial kitchen practices.



ANSI/NSF 4

Toll Free: +1 (800) 840-9577
Fax: +1 (214) 548-9392

P/N 882200 2/08

Website: www.BevLes.com
E-mail: sales@BevLes.com

BevLes
1525 East Lake Road
Erie, PA 16511

IMMEDIATELY INSPECT FOR SHIPPING DAMAGE

All containers should be examined for damage before and during unloading. The freight carrier has assumed responsibility for its safe transit and delivery. If equipment is received damaged, either apparent or concealed, a claim must be made with the delivering carrier.

A) Apparent damage or loss must be noted on the freight bill at the time of delivery. It must then be signed by the carrier representative (Driver). If this is not done, the carrier may refuse the claim. The carrier can supply the necessary forms.

B) Concealed damage or loss if not apparent until after equipment is uncrated, a request for inspection must be made to the carrier within 15 days. The carrier should arrange an inspection. Be certain to hold all contents and packaging material.

Installation and start-up should be performed by a qualified installer who thoroughly reads, understands and follows these instructions.

The **BevLes Company** takes pride in the design and quality of our products. When used as intended and with proper care and maintenance, you will experience years of reliable operation from this equipment. To ensure best results, it is important that you read and carefully follow the instructions in this manual.

Installation and start-up should be performed by a qualified installer who thoroughly reads, understands and follows these instructions.

If you have questions concerning the installation, operation, maintenance or service of this product, write Technical Service Department BevLes Company, Inc., 1525 East Lake Road, Erie, PA 16511.

1. SAFETY PRECAUTIONS

Before installing and operating this equipment be sure everyone involved in its operation is fully trained and aware of all precautions. Accidents and problems can result by a failure to follow fundamental rules and precautions.

The following words and symbols, found in this manual, alert you to hazards to the operator, service personnel or the equipment. The words are defined as follows:



DANGER: This symbol warns of imminent hazard which will result in serious injury or death.



WARNING: This symbol refers to a potential hazard or unsafe practice, which could result in serious injury or death.



CAUTION: This symbol refers to a potential hazard or unsafe practice, which may result in minor or moderate injury or product or property damage.



NOTICE: This symbol refers to information that needs special attention or must be fully understood even though not dangerous.



2. GENERAL INFORMATION

THIS MANUAL SHOULD BE RETAINED FOR FUTURE REFERENCE



WARNING: Check the data plate on this unit before installation. Connect the unit only to the voltage and frequency listed on the data plate. Connect only to 1 or 3 phase as listed on the data plate.







WARNING: Electrical and grounding connections must comply with the applicable portions of the national electrical code and/or other local electrical codes.







NOTICE: The unit when installed, must be electrically grounded and comply with local codes, or in the absence of local codes, with the national electrical code ANSI/NFPA70- latest edition. Canadian installation must comply with CSA-STANDARD C.22.2 Number 0 M1982 General Requirements-Canadian Electrical Code Part II, 109-M1981- Commercial Cooking Appliances.







 **WARNING:** In Europe, appliance must be connected by an earthing cable to all other units in the complete installation and thence to an independent earth connection in compliance with EN 60335-1 and/or local codes 

 **NOTICE:** This equipment has been engineered to provide you with year round dependable service when used according to the instructions in this manual and standard commercial kitchen practices. 

 **WARNING:** Do not use oven cleaners, caustic solutions or mechanical means to clean the appliance as they will damage the interior stainless surface. 

 **WARNING:** This appliance must be serviced by an Authorized Service Technician only. Disconnect the power supply before cleaning or servicing the cabinet. Regular and thorough cleaning will help to keep the cabinets operating properly. If service is required, contact an Authorized Service Agency, your dealer or the factory to obtain a qualified technician for the required maintenance/service. 

 **WARNING:** Disconnect device from electrical power supply and place a Tag Out-Lockout on the power plug, indicating that you are working on the circuit. 

 **WARNING:** Neglecting to keep fan opening clean could result in cabinet failure. 

IMPORTANT FOR FUTURE REFERENCE

Please complete this information and retain this manual for the life of the equipment. For Warranty Service and/or Parts, this information is required.

Model Number Serial Number Date Purchased

TABLE OF CONTENTS

<u>SECTION</u>	<u>ITEM</u>	<u>PAGE</u>
1	Safety Precautions	2
2	General Information	2
3	Installation Instructions	3
4	Operating Instructions	4
5	Cleaning Instructions	5
6	Specifications	6
7	Parts List & Exploded Views	9
8	Wiring Diagrams	13
9	Climate Select Recommended Settings - Guidelines Only	15
10	Warranty	16

The data plate for the unit is located on the left side panel on the upper rear of that panel. Check the voltage requirements on the data plate. Connect the unit only to the voltage configuration specified on the data plate.

3. INSTALLATION INSTRUCTIONS

BEFORE USING THE CABINET:

1. Place cabinet on level floor.
2. Plug unit into proper wall outlet.
3. Fill water pan with water.
4. Place the cabinet in a well ventilated area.
5. Push the power switch to ON and set the Air thermostat to 9. Let run for one hour.
6. Let the cabinet cool and clean the inside with a mild detergent and hot water.

CAUTION: During operation the air is **VERY HOT** when the door is opened.

4. OPERATING INSTRUCTIONS

USING THE CABINET TO PROOF:

1. Fill water pan with HOT water.
2. Turn power switch ON.
3. Set Air thermostat to PROOF (No. 1).
4. Set HUMIDITY thermostat to 3 ½.
5. Let the unit preheat for 30 minutes.
6. Put fresh or fully thawed dough into cabinet.

NOTE: Do not put frozen dough into cabinet. Refer to Temperature Settings for more proofing options.

FOR HOLDING FOOD WITH NO HUMIDITY:

No water is needed in water pan.

1. Set HUMIDITY thermostat to "0".
This will turn the water heater off.
2. Push power switch to ON.
3. Set AIR thermostat to desired temperature.
4. Preheat the cabinet for 30 minutes.

NOTE: Safe food holding temperature is 150°F/65°C or higher. Refer to Temperature and Humidity Settings Chart for options.

FOR HOLDING FOOD WITH HUMIDITY:

It is important to maintain water in the water pan when using the humidity feature.

1. Fill water pan with HOT water.
2. Push power switch to ON.
3. Set AIR thermostat to desired temperature.
4. Set HUMIDITY thermostat to desired setting.
5. Preheat the cabinet for 30 minutes.
6. Place product into cabinet.

Note: Refer to Temperature and Humidity Settings Chart for options.

FULL SIZE CLIMATE SELECT WITH SOLID STATE CONTROL

WATER SETTINGS											
AIR	0	1	2	3	4	5	6	7	8	9	10
1	80 F	83 F 51%	86.5 F 60%	90 F 78%	95.5 F 82%	99.0 F 86 %	104 F 86%	108 F 90%	118 F 92%	134 F 96%	200 F 99%
2	99 F	99 F 27%	100 F 31%	101 F 43%	99 F 66%	99 F 78%	101 F 86%	107 F 89%	114 F 97%	127 F 96%	200 F 99%
3	110 F	113 F 28%	113 F 37%	114 F 49%	115 F 59%	115 F 72%	116 F 83%	117 F 93%	125 F 97%	140 F 98%	200 F 99%
4	130 F	130 F 12%	130 F 14%	132 F 22%	132 F 30%	132 F 43%	134 F 52%	135 F 61%	135 F 74%	136 F 91%	199.5 F 99%
5	145 F	145 F 16%	14.5 F 17%	147 F 21%	146 F 23%	146 F 31%	146 F 43%	147 F 52%	147 F 66%	147 F 85%	199 F 99%
6	155 F	156 F 10%	156 F 11%	157 F 12%	159 F 15%	160 F 22%	160 F 32%	162 F 40%	162 F 50%	162 F 68%	200 F 99%
7	166 F	171 F 8%	172 F 9%	172 F 10%	172 F 13%	172 F 17%	172 F 25%	173 F 30%	172 F 40%	173 F 51%	200 F 99%
8	182 F	182 F 5%	182 F 6%	183 F 8%	182 F 11%	183 F 14%	185 F 18%	185 F 22%	188 F 30%	188 F 43%	200 F 99%
9	192 F	198 F 3%	198 F 4%	198 F 5%	198 F 7%	198 F 10%	199 F 13%	199 F 17%	199 F 24%	200 F 36%	200 F 99%
10	205 F	208 F 4%	212 F 4%	212 F 5%	215 F 6%	215 F 8%	215 F 11%	215 F 14%	215 F 21%	215 F 28%	200 F 99%

Note: These settings are based on tests under laboratory conditions. Results will change at your location based on weather conditions and elevation. Experiment with the settings to determine the proper setting for your use.

5. CLEANING INSTRUCTIONS

Daily Cleaning:

1. Turn off power switch and unplug the unit from the wall outlet.
2. Allow the unit to cool before cleaning.



WARNING: To avoid burns allow the unit to cool before cleaning.



3. Open the doors and remove all pans and hangers from the unit. Take them to the sink and thoroughly clean.
4. Clean the interior and exterior of the cabinet with warm soapy water.



WARNING: Do not use steel wool or other abrasive cleaners. Do not use cleaners or sanitizers containing chlorine, iodine, ammonia or bromine as these will damage the finish on the stainless steel.



WARNING: Do not use a water jet (pressure sprayer) to clean the unit. This could damage some of the components.



5. Wash the control panel with a damp cloth, do not use excess water on the control panel.
6. Reinstall the hangers and pans. Leave the door partially open to allow these parts and the interior of the cabinet to thoroughly dry.

Weekly Cleaning:

1. In addition to the daily cleaning remove the top air ducts from each side of the internal cabinet. To remove these lift up and then pull away from the internal wall.
2. Remove the bottom air duct from each side of the internal cabinet. After the top air ducts have been removed you can lift and pull away from the internal wall.
3. Take these parts to the sink and thoroughly clean.



WARNING: Do not use steel wool or other abrasive cleaners. Do not use cleaners or sanitizers containing chlorine, iodine, ammonia or bromine as these will damage the finish on the stainless steel.



4. Open the drain valve and empty the water into a pan or floor drain.



WARNING: Hot Water. Do not place your hands under the drain while draining the unit. Failure to do so could result in severe burns and injury.



5. Liberally spray the water pan with a concentrated deliming agent and let stand for 10 minutes.



CAUTION: Delime the unit weekly, failure to do so will shorten the life of the components.



6. Scrub the pan with a brush and flush the water.
7. Rinse the pan.
8. Fill the water pan.
9. Reinstall these parts by installing the bottom air ducts first. Place the openings in the back of the air duct over the spacers on the side wall and slide down into position. After the bottom air ducts are installed repeat the process with the top air ducts.

Monthly Cleaning

1. Vacuum the openings in the center of the rear panel.



Caution: Failure to clean these openings on a regular basis can cause the control components to overheat and shorten their life.



6. SPECIFICATIONS:

SPECIFICATIONS - CLIMATE SELECT (FULL SIZE) MODEL HCSS74W12

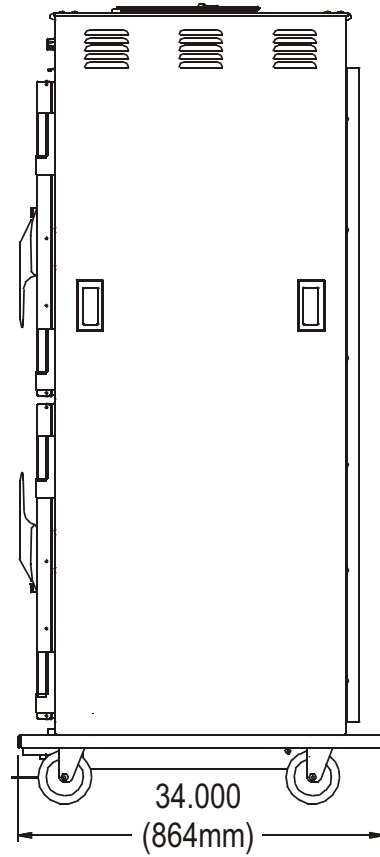
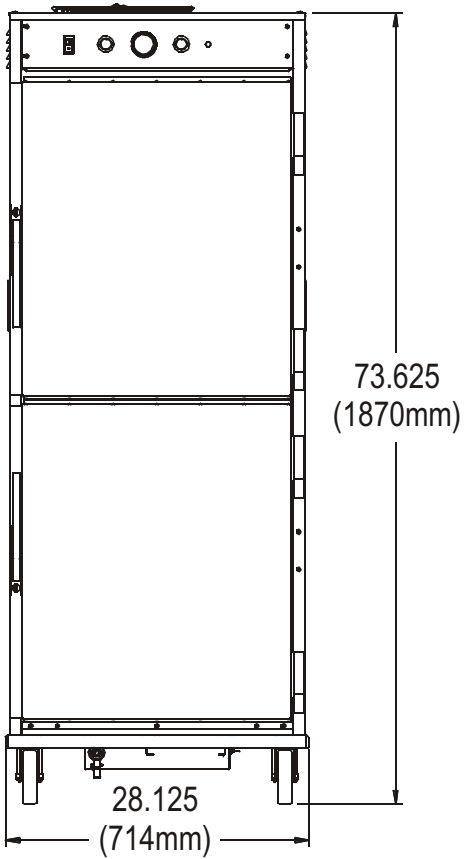
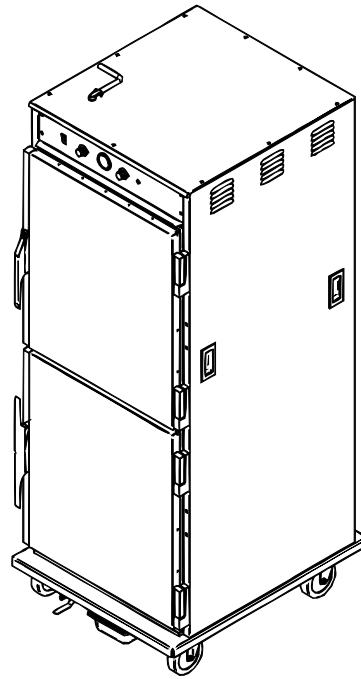
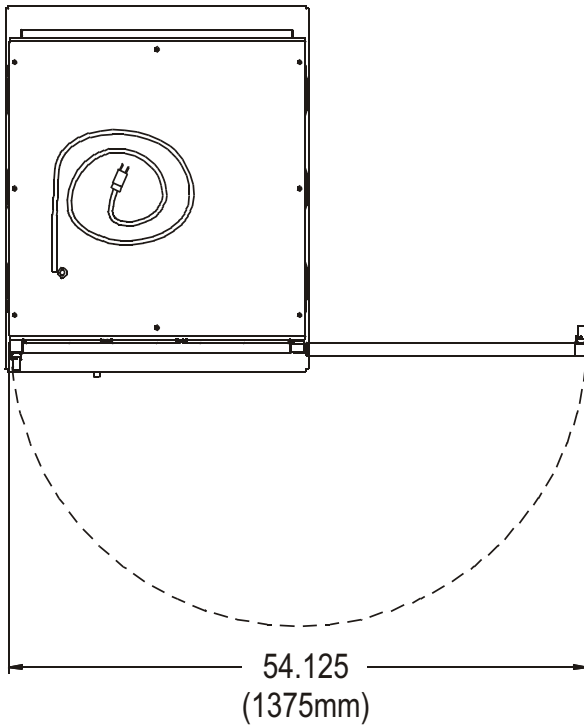

SPECIFICATIONS - CLIMATE SELECT (HALF SIZE) MODEL HCSS44W6

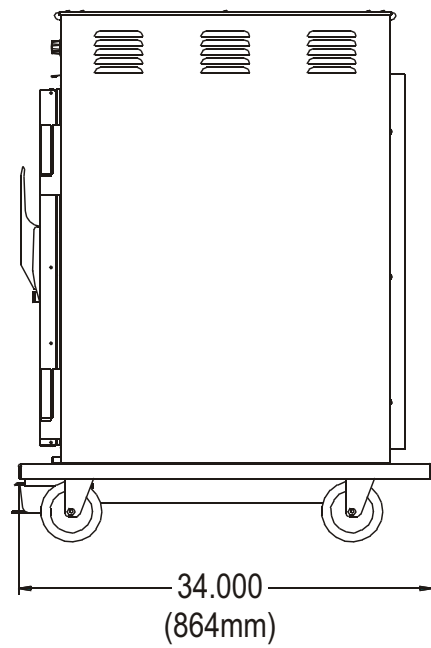
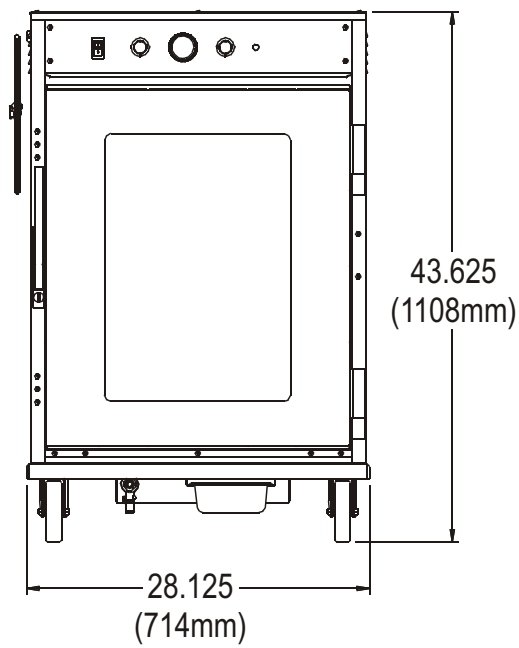
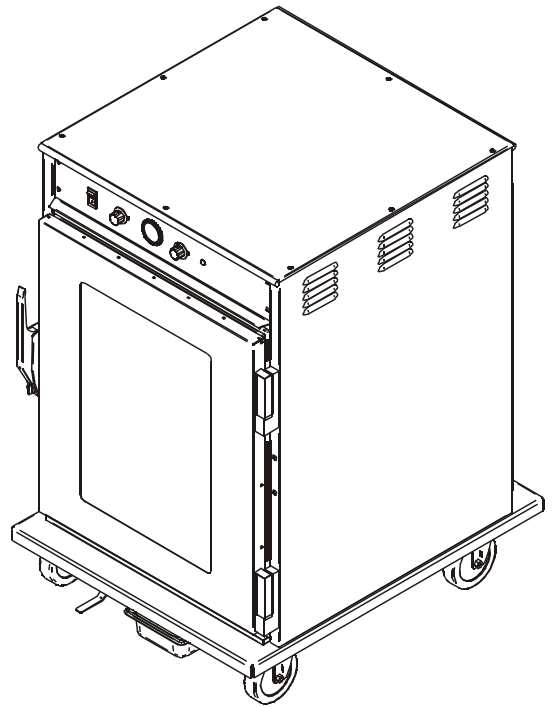
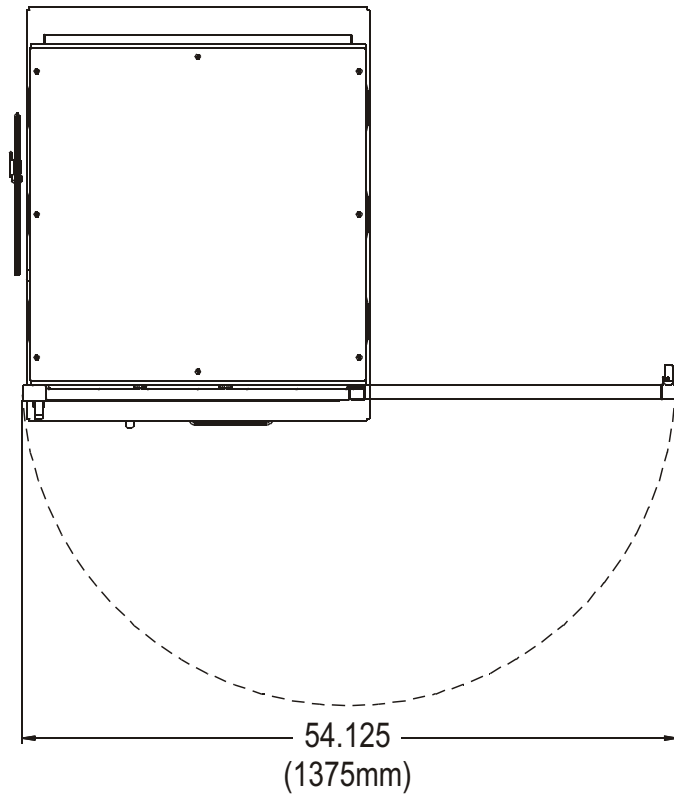

Note: Unit shown with optional glass doors.

SPECIFICATIONS - CLIMATE SELECT (UNDER COUNTER DESIGN) MODEL HCSS34W5

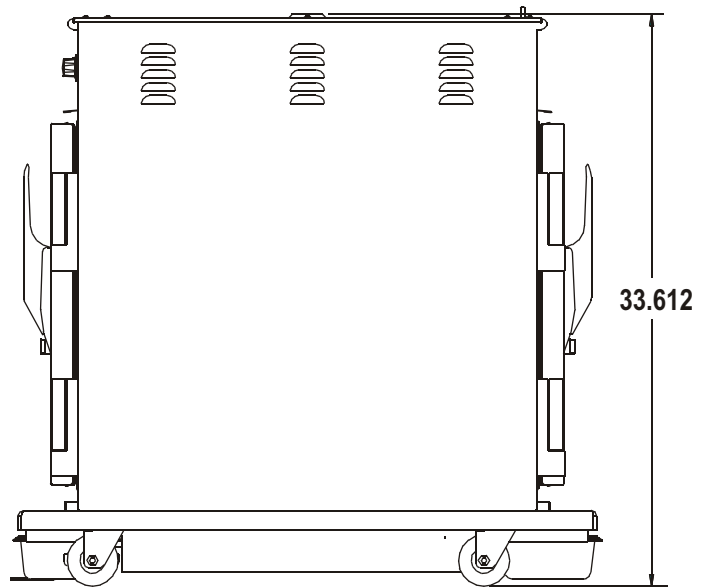
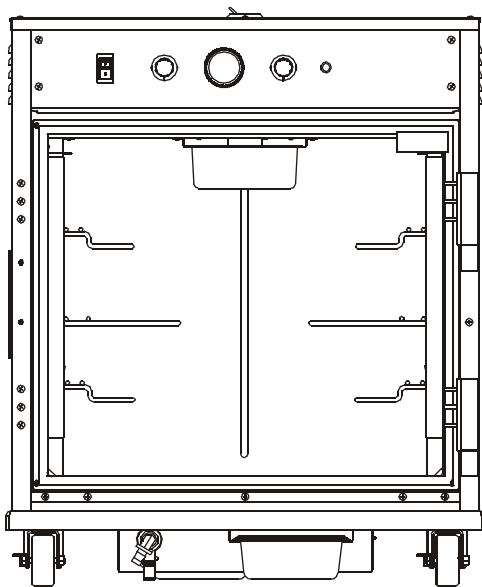
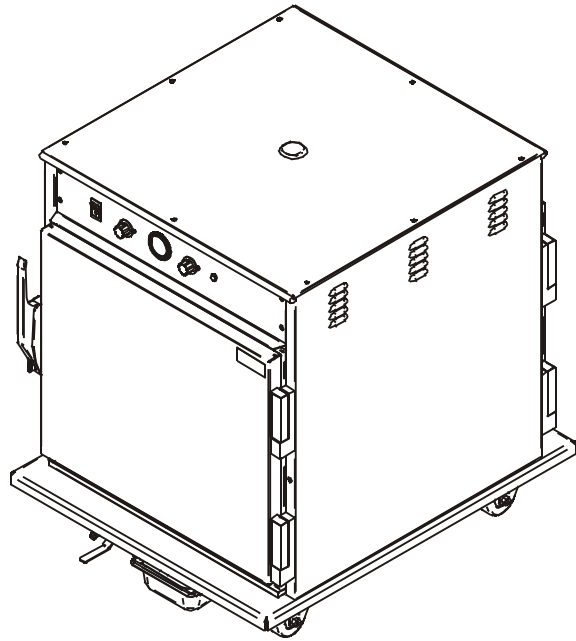
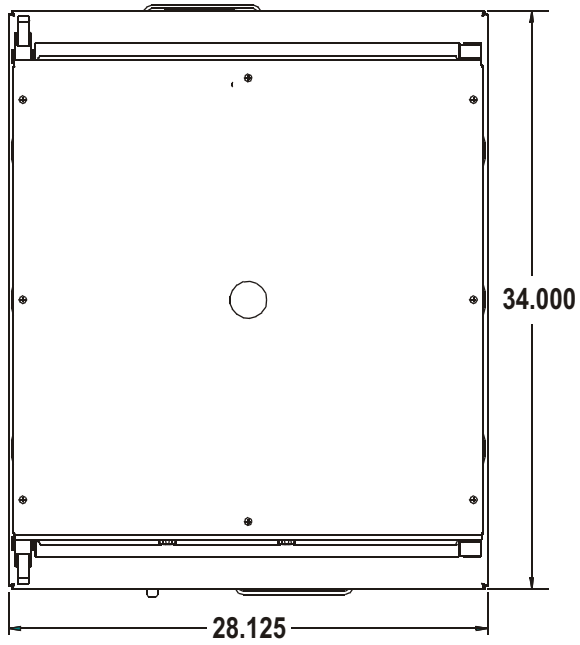

7. PARTS LIST & EXPLODED VIEWS

PARTS LIST - CLIMATE SELECT				
(FULL SIZE HCSS74W12, HALF SIZE HCSS44W6 & UNDER COUNTER HCSS34W5)				
Item	120V P/N	208V P/N	240V P/N	Description
1	781185	781185	781185	Magnetic Latch
2	784692	784692	784692	Lift-Off Hinge
3	781155	781155	781155	Magnetic Gasket
4	781284	781284	781284	Hanger 25 x 5 Stainless Steel
5	741134	741134	741134	Bottom Air Duct (Full Size Units Only)
6	741135	741135	741135	Top Air Duct (Full Size Units Only)
7	780040	780040	780040	5" Caster
8	780036	780036	780036	5" Caster w/Brake
9	741113	741113	741113	Water Pan Cover
10	785018	785018	785018	Hi Limit Switch - Water Pan
11	750357	750357	750357	Male Connector - Water Probe
12	781154	781154	781154	Ball Valve - Drain
13	781157	781157	781157	90° Fitting
14	781147	781147	781147	Pull Handle (Full Size Units Only)
15	720319	720319	720319	Door
16	720321	720321	720321	Door With Window
17*	783004	783004	783004	Spacer - Air Duct (Not Shown)
18	782068	701015	701015	Power Cord
19	1101500	1101500	1101500	Stain Relief
20	1302200	1302200	1302200	Power Switch
21	1512503	1512503	1512503	Low Water Light
22	784058	784058	784058	Thermometer
23	781173	781173	781173	Temperature Controller
24	781227	781227	781227	Probe - Air And Water
25	781189	781189	781189	Thermostat Knob
26	781276	781276	781276	Hi Limit Switch - Air
27	781149	781149	781149	Float Switch
28	784680	784682	784682	Cooling Fan
29	781160	781163	781163	Air Heater
30	781190	781277	781278	Water Heater
31	781279	781280	781280	Blower Motor
32	1210810	1210810	1210810	Blower Wheel
33	1101600	1101600	1101600	Terminal Block
34	781172	781172	781172	Water Pan
35	741094	741094	741094	Channel Support
36	741485	741485	741485	Bottom Air Duct (Half Size Units Only)
37	780108	780108	780108	3" Caster
38	780112	780112	780112	3" Caster w/Brake
39	742050	742050	742050	Air Duct
40	741110	741488	741488	Water Pan Weldment (Before 1/08)
	742097	742096	742096	Water Pan Weldment (After 1/08)
41	760279	760279	760279	Gasket (Before 1/08)
	760290	760290	760290	Gasket (After 1/08)
42	760281	760281	760281	Gasket (Before 1/08)
	760291	760291	760291	Gasket (After 1/08)
43	781386	781386	781386	Magnetic Gasket
44	720735	720735	720735	Door
45	742051	742051	742051	Channel Support

EXPLODED VIEW - CLIMATE SELECT (HALF SIZE)

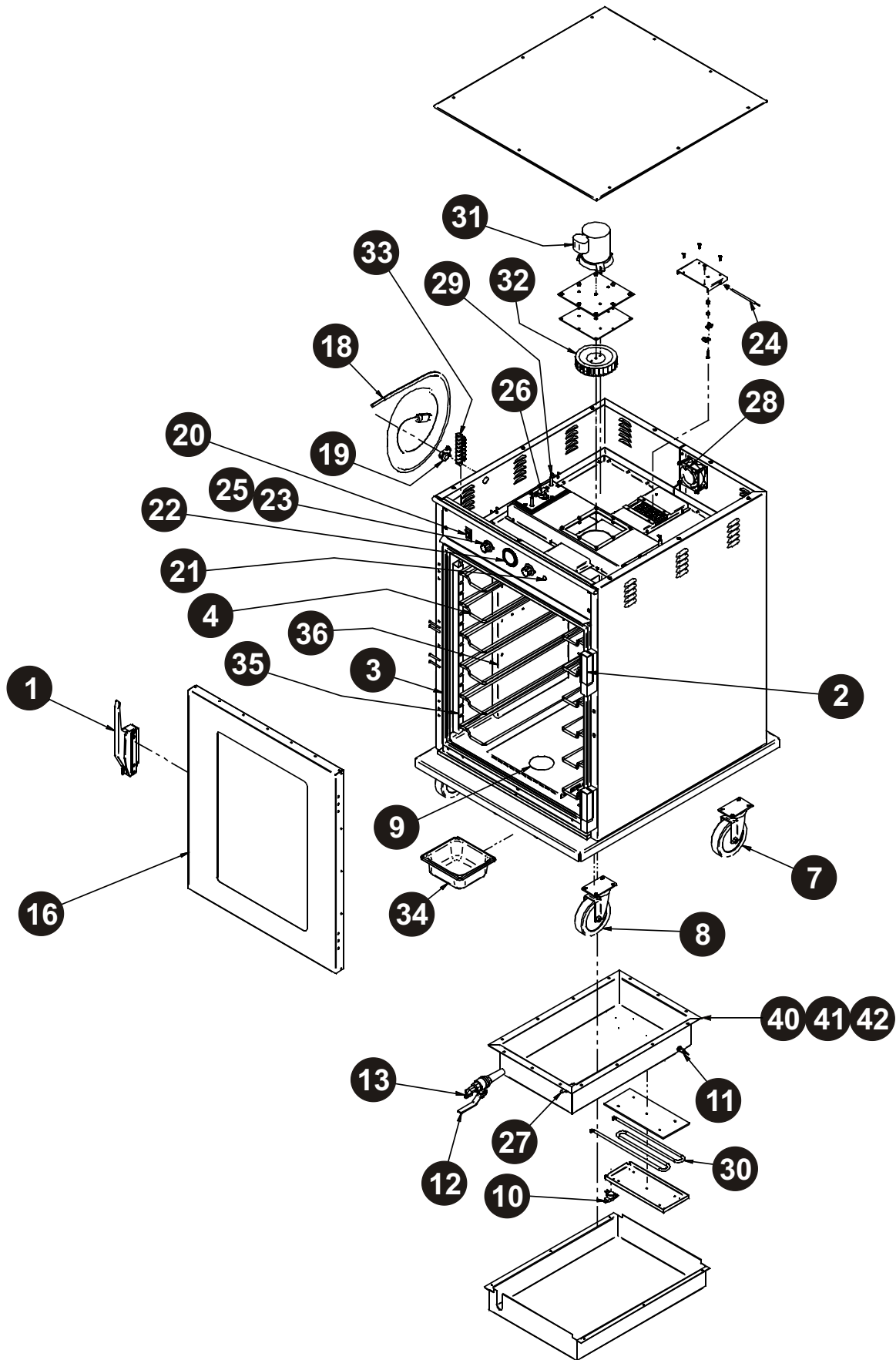

EXPLODED VIEW - CLIMATE SELECT (FULL SIZE)

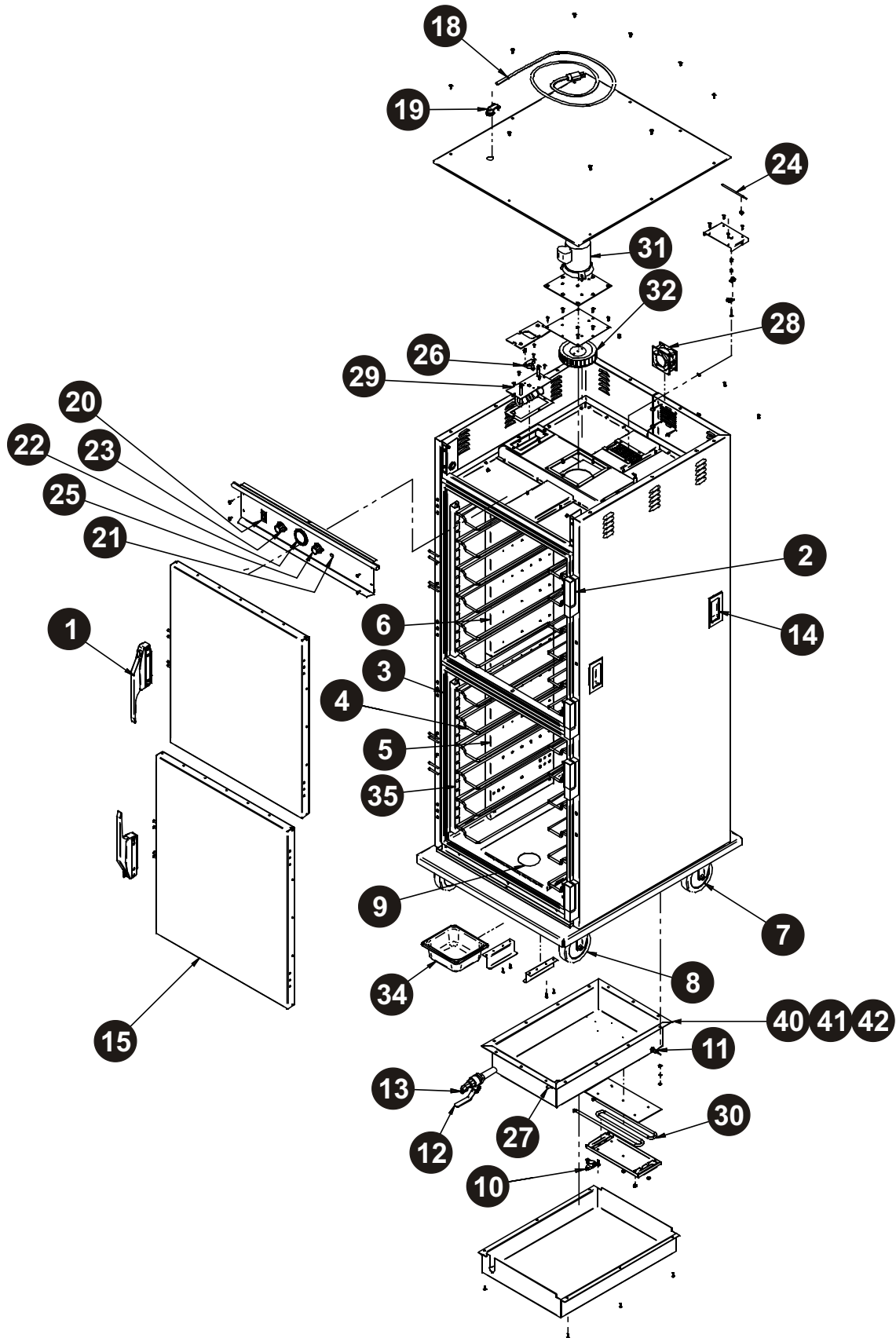

EXPLODED VIEW - CLIMATE SELECT (UNDER COUNTER DESIGN) MODEL HCSS34W5

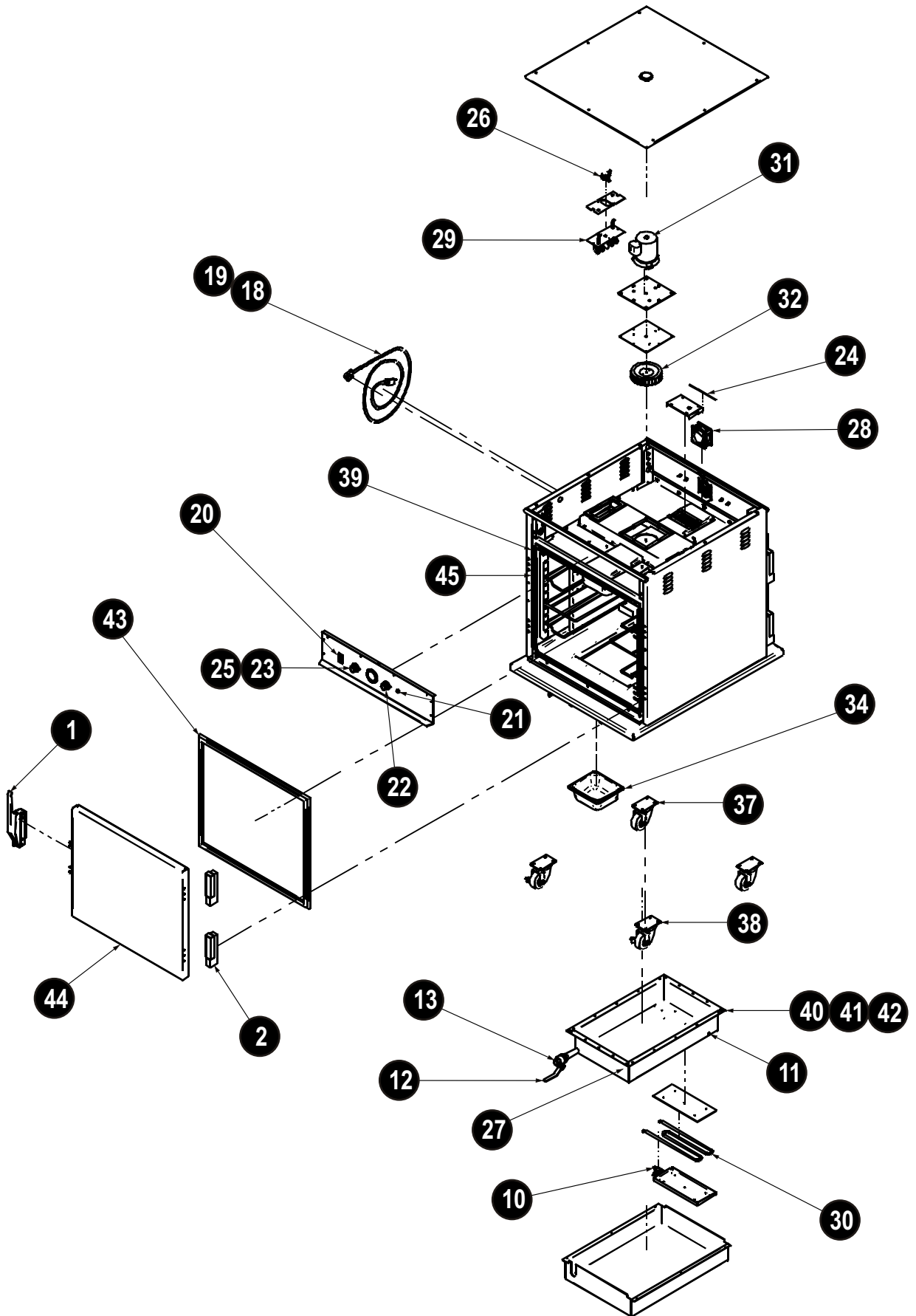

8. WIRING DIAGRAMS

WIRING DIAGRAM - CLIMATE SELECT

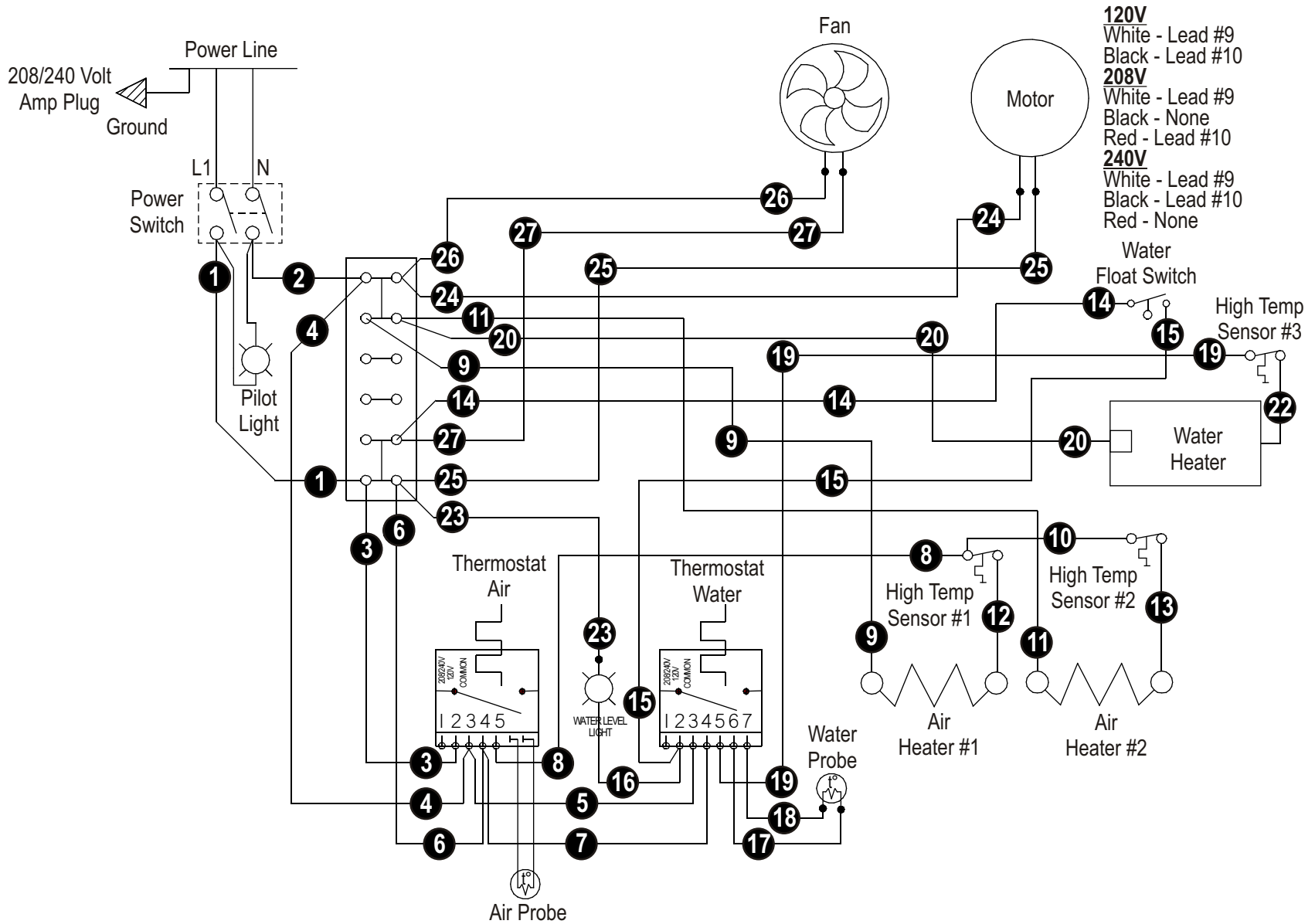

WIRING DIAGRAM - CLIMATE SELECT (w/OPTIONAL DIGITAL CONTROL)

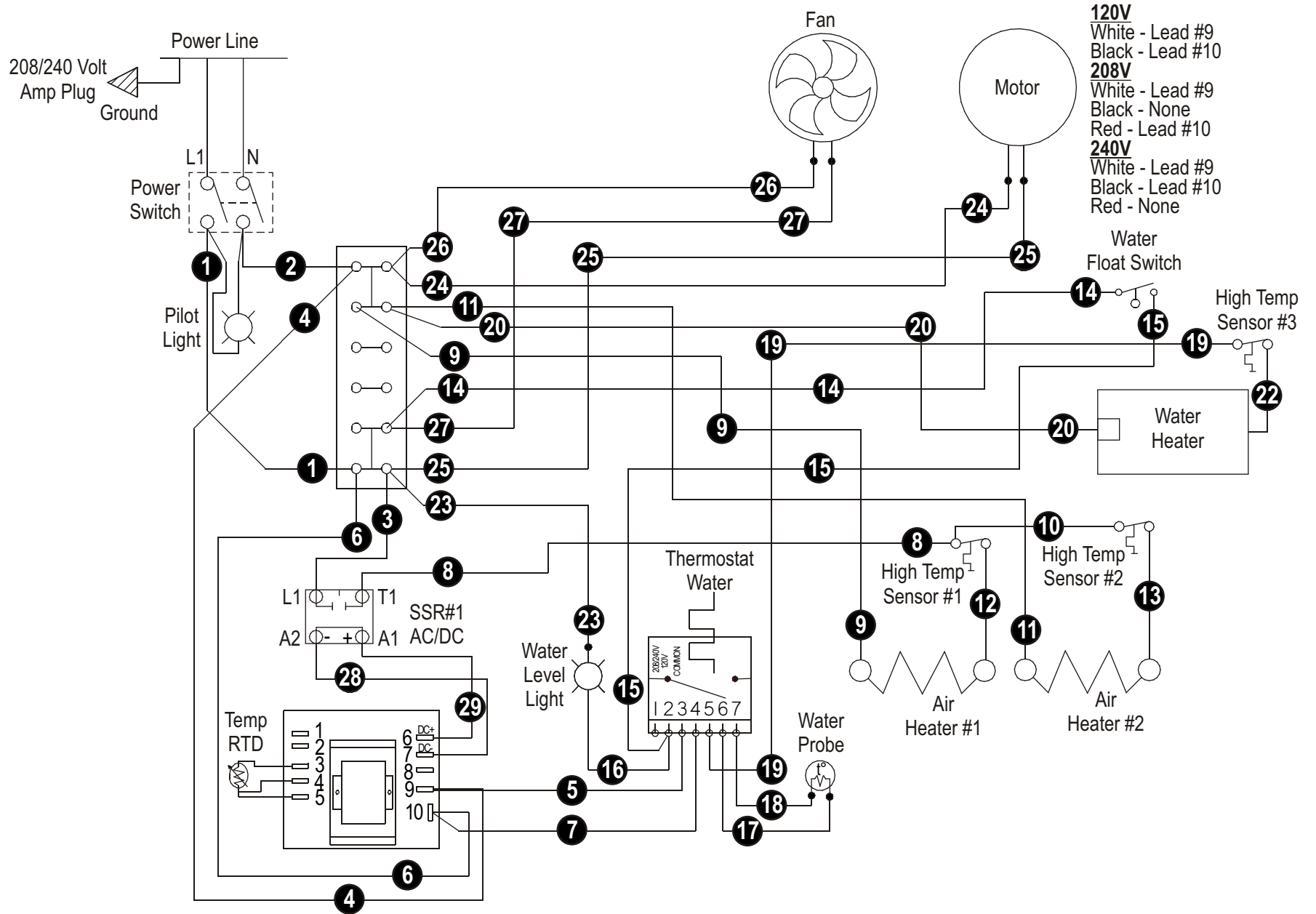

9. CLIMATE SELECT RECOMMENDED SETTINGS - GUIDELINES ONLY



Item	Recommended Temperature Range	Approximate Dial Setting For Temperature	Suggested Humidity %	Approximate Dial Setting For Humidity	Comments
Baked Potato	170 - 180°F	7	75 - 80	9	Foil on Potato not required, but if baking process required foil, then it can be left on.
Biscuits	150 - 160°F	5	85 - 90	9	Recommend single layer on bun pan
Fish Broiled/Baked	165 - 175°F	7	75 - 80	6	Recommend single layer on bun pan
Fish Fried	165 - 175°F	7	35 - 45	6	Recommend single layer on bun pan
Breakfast Sausage	165 - 175°F	6	75 - 80	9	Can be stacked in 12 x 20 pans, but should not be stacked over the top of pan.
Poultry Broiled/Baked	170 - 180°F	7	80 - 85	6	Recommend placing on bun pan with roasting rack. Whole poultry with the large
Poultry Fried	170 - 180°F	7	35 - 45	6	cavity opening facing to the left.
Croissants	145 - 155°F	5	75 - 80	9	Recommend single layer on bun pan
Eggs	150 - 160°F	5	75 - 80	8	Can be stacked in 12 x 20 pans, but should not be stacked over the top of pan.
French Toast	160 - 170°F	5	80 - 85	9	Can be stacked in 12 x 20 pans, but should not be stacked over the top of pan.
Hamburger patties	170 - 180°F	6	85 - 90	9	Can be stacked in 12 x 20 pans, but should not be stacked over the top of pan.
Hot Dogs	170 - 180°F	6	85 - 90	9	Can be stacked in 12 x 20 pans, but should not be stacked over the top of pan.
Muffins	150 - 160°F	5	80 - 85	9	Recommend single layer on bun pan
Pancakes	150 - 160°F	5	80 - 85	9	Can be stacked in 12 x 20 pans, but should not be stacked over the top of pan.
Tortillas	150 - 160°F	5	70 - 75	9	Can be stacked in 12 x 20 pans, but should not be stacked over the top of pan.
Vegetables	165 - 170°F	5	80 - 85	9	Can be stacked in 12 x 20 pans, but should not be stacked over the top of pan.
Waffles	150 - 160°F	5	80 - 85	9	Can be stacked in 12 x 20 pans, but should not be stacked over the top of pan.
Cinnamon Rolls	150 - 160°F	5	80 - 85	9	Recommend single layer on bun pan
Pizza	170 - 175°F	7	25 - 35	6	Recommend perforated bun pan
Prime Rib	150 - 165°F	6	75 - 85	9	Recommend placing on bun pan with roasting rack
Ribs	150 - 165°F	6	75 - 85	9	Recommend placing on bun pan with roasting rack

15

Suggested settings only: Actual settings may vary depending on ingredients, cooking methods, & individual preferences.

Suggested holding times only: Actual holding times may vary depending on frequency of door openings, ingredients, cooking methods, & individual preferences.



10. BEVLES COMPANY LIMITED WARRANTY

1525 East Lake Road, Erie, PA 16511
Toll Free: (800) 840-9577 • Fax: (800) 548-9392

1. Bevles warrants to the original purchaser that on the date the equipment is shipped (sold), it will be free of defects in materials or workmanship. Bevles will, at it's discretion, repair or replace, during the warranty period printed below, any part that has a defect in material or workmanship that was present when the product shipped from Bevles, and which manifests itself during the warranty period under normal use and service.
 - Parts: Two* years from date of original shipment from the Bevles factory.
 - Labor: One** year from date of original shipment from the Bevles factory.

* Air Circulation Blower Assemblies (motors) and Power Switches shall be one year from date of original shipment.

Calrod "Air" Heating Elements shall be three years from date of original shipment.

** All electrical components 120 days from date of original shipment.
2. Bevles must be contacted, and pre-approval must be issued by the Bevles factory prior to any type of service being performed. Bevles assumes no responsibility for any charges that were not expressly authorized by the Bevles factory, or for any charges that exceed, in Bevles' sole judgement, normal and customary amounts.
3. Bevles will pay UPS Ground charges for any part that has a defect in material or workmanship that was present when the product shipped from Bevles, and which manifests itself during the **first year** of the warranty period under normal use and service. All warranty replacement parts will ship F.O.B. Bevles factory, Erie, PA 16511
4. This warranty shall be void in its entirety if any abuse of, misuse of, alteration/modification of or improper maintenance of original product occurs. If, at any time a claim is reported to Bevles, and the purchaser is delinquent in payment for the product, warranty will not apply.
5. Buyer's Remedies-If a Bevles product fails due to a defect in material or workmanship in conformity with the warranties in paragraph one, buyer shall notify Bevles of such failure within a reasonable time, but in no event beyond fifteen (15) days of such discovery of defect in material or workmanship. Bevles shall provide, in its sole discretion, either the repair or replacement of any defective or any non-conforming part. Bevles specifically disavows any other representation, warranty or liability relating to the continued use of the product.
6. Exclusion of consequential and incidental damages-In no event shall Bevles be liable for any incidental, special, indirect, or consequential damages, whether resulting from non-delivery or from the use, misuse, or inability to use the product, or from defects in the product, or from Bevles' own negligence or other tort. This exclusion applies regardless of whether such damages are sought for breach of warranty, breach of contract, negligence, or strict liability in tort or under any other legal theory.
7. Disclaimer of warranties-The warranties contained in paragraph one above are the exclusive warranties given by Bevles and supersede any prior, contrary, or additional representations, whether oral or written. Bevles hereby disclaims and excludes all other warranties-whether expressed, implied, or statutory-including any warranty of merchantability, any warranty of fitness for a particular purpose, and any implied warranties otherwise arising from course of dealing or usage of trade.

1/05