

BUNN®

**DUAL® &
DUAL® SH**
(Serial # DUAL010000 - Up)

**SINGLE® &
SINGLE® SH**
(Serial # SNG0005000 - Up)

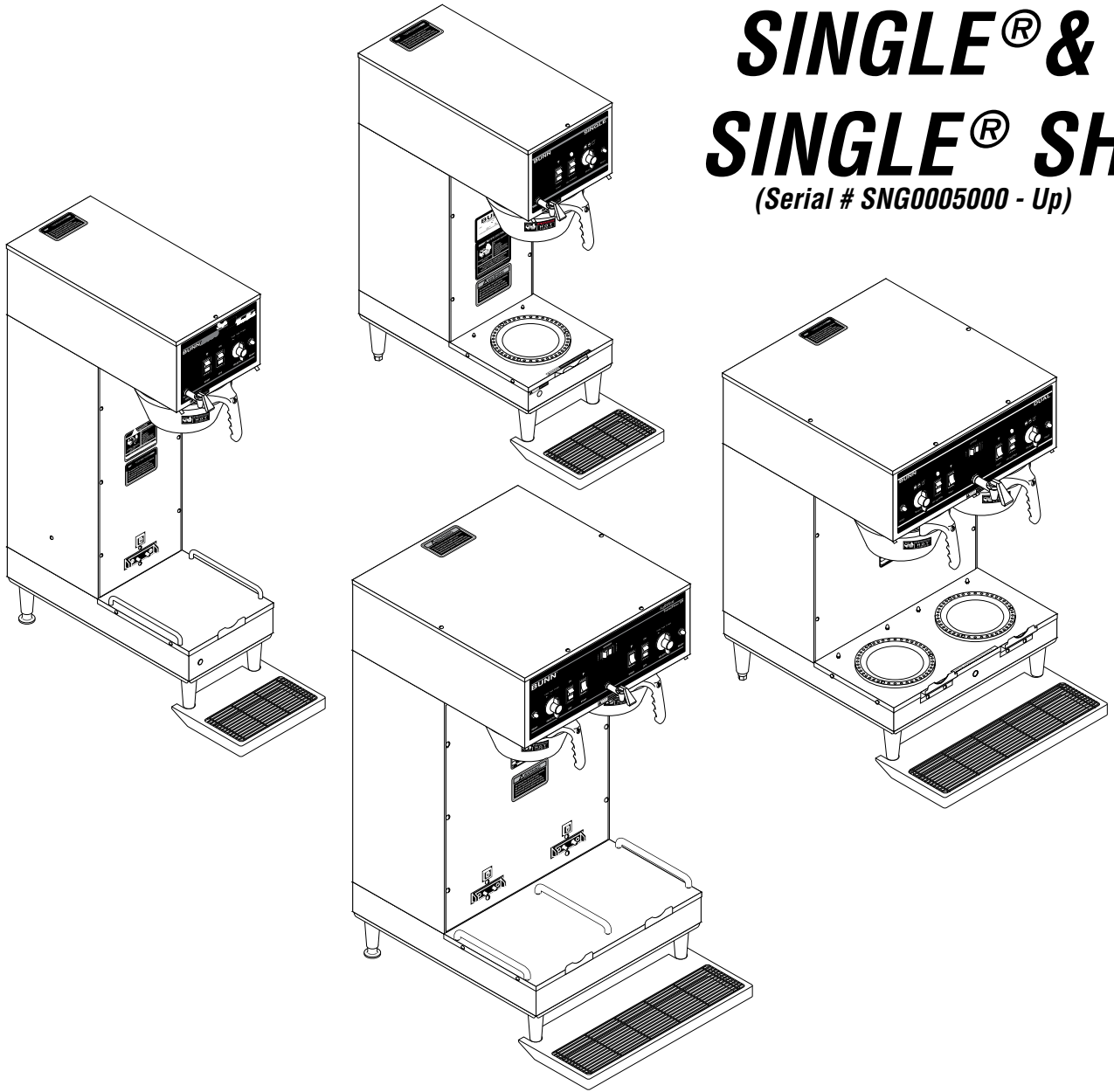

SERVICE & REPAIR MANUAL

BUNN-O-MATIC CORPORATION

POST OFFICE BOX 3227

SPRINGFIELD, ILLINOIS 62708-3227

PHONE: (217) 529-6601 FAX: (217) 529-6644

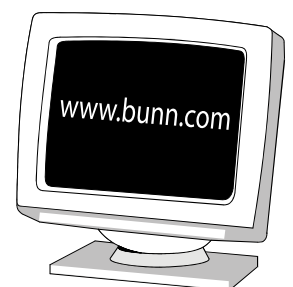

BUNN-O-MATIC COMMERCIAL PRODUCT WARRANTY

Bunn-O-Matic Corp. ("BUNN") warrants equipment manufactured by it as follows:

- 1) Airpots, thermal carafes, decanters, GPR servers, iced tea/coffee dispensers, MCP/MCA pod brewers thermal servers and Thermofresh servers (mechanical and digital)- 1 year parts and 1 year labor.
- 2) All other equipment - 2 years parts and 1 year labor plus added warranties as specified below:
 - a) Electronic circuit and/or control boards - parts and labor for 3 years.
 - b) Compressors on refrigeration equipment - 5 years parts and 1 year labor.
 - c) Grinding burrs on coffee grinding equipment to grind coffee to meet original factory screen sieve analysis - parts and labor for 4 years or 40,000 pounds of coffee, whichever comes first.

These warranty periods run from the date of installation BUNN warrants that the equipment manufactured by it will be commercially free of defects in material and workmanship existing at the time of manufacture and appearing within the applicable warranty period. This warranty does not apply to any equipment, component or part that was not manufactured by BUNN or that, in BUNN's judgment, has been affected by misuse, neglect, alteration, improper installation or operation, improper maintenance or repair, non periodic cleaning and descaling, equipment failures related to poor water quality, damage or casualty. In addition, the warranty does not apply to replacement of items subject to normal use including but not limited to user replaceable parts such as seals and gaskets. This warranty is conditioned on the Buyer 1) giving BUNN prompt notice of any claim to be made under this warranty by telephone at (217) 529-6601 or by writing to Post Office Box 3227, Springfield, Illinois 62708-3227; 2) if requested by BUNN, shipping the defective equipment prepaid to an authorized BUNN service location; and 3) receiving prior authorization from BUNN that the defective equipment is under warranty.

THE FOREGOING WARRANTY IS EXCLUSIVE AND IS IN LIEU OF ANY OTHER WARRANTY, WRITTEN OR ORAL, EXPRESS OR IMPLIED, INCLUDING, BUT NOT LIMITED TO, ANY IMPLIED WARRANTY OF EITHER MERCHANTABILITY OR FITNESS FOR A PARTICULAR PURPOSE. The agents, dealers or employees of BUNN are not authorized to make modifications to this warranty or to make additional warranties that are binding on BUNN. Accordingly, statements by such individuals, whether oral or written, do not constitute warranties and should not be relied upon.

If BUNN determines in its sole discretion that the equipment does not conform to the warranty, BUNN, at its exclusive option while the equipment is under warranty, shall either 1) provide at no charge replacement parts and/or labor (during the applicable parts and labor warranty periods specified above) to repair the defective components, provided that this repair is done by a BUNN Authorized Service Representative; or 2) shall replace the equipment or refund the purchase price for the equipment.

THE BUYER'S REMEDY AGAINST BUNN FOR THE BREACH OF ANY OBLIGATION ARISING OUT OF THE SALE OF THIS EQUIPMENT, WHETHER DERIVED FROM WARRANTY OR OTHERWISE, SHALL BE LIMITED, AT BUNN'S SOLE OPTION AS SPECIFIED HEREIN, TO REPAIR, REPLACEMENT OR REFUND.

In no event shall BUNN be liable for any other damage or loss, including, but not limited to, lost profits, lost sales, loss of use of equipment, claims of Buyer's customers, cost of capital, cost of down time, cost of substitute equipment, facilities or services, or any other special, incidental or consequential damages.

392, AutoPOD, AXIOM, BrewLOGIC, BrewMETER, Brew Better Not Bitter, BrewWISE, BrewWIZARD, BUNN Espresso, BUNN Family Gourmet, BUNN Gourmet, BUNN Pour-O-Matic, BUNN, BUNN with the stylized red line, BUNNlink, Bunn-OMatic, Bunn-O-Matic, BUNNserve, BUNNSERVE with the stylized wrench design, Cool Froth, DBC, Dr. Brew stylized Dr. design, Dual, Easy Pour, EasyClear, EasyGard, FlavorGard, Gourmet Ice, Gourmet Juice, High Intensity, iMIX, Infusion Series, Intellisteam, My Café, Phase Brew, PowerLogic, Quality Beverage Equipment Worldwide, Respect Earth, Respect Earth with the stylized leaf and coffee cherry design, Safety-Fresh, savemycoffee.com, Scale-Pro, Silver Series, Single, Smart Funnel, Smart Hopper, SmartWAVE, Soft Heat, SplashGard, The Mark of Quality in Beverage Equipment Worldwide, ThermoFresh, Titan, trifecta, Velocity Brew, A Partner You Can Count On, Air Brew, Air Infusion, Beverage Bar Creator, Beverage Profit Calculator, Brew better, not bitter., BUNNSource, Coffee At Its Best, Cyclonic Heating System, Daypart, Digital Brewer Control, Nothing Brews Like a BUNN, Pouring Profits, Signature Series, Tea At Its Best, The Horizontal Red Line, Ultra are either trademarks or registered trademarks of Bunn-O-Matic Corporation.

TROUBLESHOOTING

A troubleshooting guide is provided to suggest probable causes and remedies for the most likely problems encountered. If the problem remains after exhausting the troubleshooting steps, contact the Bunn-O-Matic Technical Service Department.

- Inspection, testing, and repair of electrical equipment should be performed only by qualified service personnel.
- All electronic components have 120 - 240 volt ac and low voltage dc potential on their terminals. Shorting of terminals or the application of external voltages may result in board failure.
- Intermittent operation of electronic circuit boards is unlikely. Board failure will normally be permanent. If an intermittent condition is encountered, the cause will likely be a switch contact or a loose connection at a terminal or crimp.
- Solenoid removal requires interrupting the water supply to the valve. Damage may result if solenoids are energized for more than ten minutes without a supply of water.
- The use of two wrenches is recommended whenever plumbing fittings are tightened or loosened. This will help avoid twists and kinks in the tubing.
- Make certain that all plumbing connections are sealed and electrical connections tight and isolated.
- This brewer is heated at all times. Keep away from combustibles.

WARNING

- Exercise extreme caution when servicing electrical equipment.
- Disconnect the brewer from the power source when servicing, except when electrical tests are specified.
- Follow recommended service procedures.
- Replace all protective shields or safety notices.

Problem	Probable Cause	Remedy
Equipment will not operate.	1. No power or incorrect voltage.	(A1) Check the terminal block for 120 volts across the red and white terminals and the black and white terminals on 120V, 120/208 or 120/240 volt brewers. (A2) Check the terminal block for 200 volts on "B Series" brewers or 240 volts on "A Series" brewers across the red and black terminals. (B) Check circuit breakers or fuses.
Brew cycle will not start.	1. No water 2. Water strainer/flow control (.750 GPM)	Check plumbing and shut-off valves (A) Direction of flow arrow must be pointing towards brewer. (B) Remove the strainer/flow control and check for obstructions. Clear or replace.

TROUBLESHOOTING (cont.)

Problem

Probable Cause

Remedy

Brew cycle will not start (cont.)

3. ON/OFF switch

Refer to *Service* - ON/OFF switch for testing procedures.

4. Start switch

Refer to *Service* - Start switch for testing procedures.

5. Timer

Refer to *Service* - Timer for testing procedures.

6. Dispense Valve

Refer to *Service* - Dispense valve for testing procedures.

7. Control Assembly (Electronic)

Refer to *Service* - Control assembly for testing procedures.

8. Server not in place (SH models)

Make sure server is in place and server present lamp is lit.

Automatic refill will not operate

1. No water

Check plumbing and shut-off valves.

2. Water strainer/flow control

(A) Direction of flow arrow must be pointing towards brewer.

(B) Remove the strainer/flow control and check for obstructions. Clear or replace.

3. Solenoid Valve

Refer to *Service* - Solenoid valve for testing procedures.

4. Limit thermostat (Electro/mechanical and Electronic)

Refer to *Service* - Limit thermostat for testing procedures.

5. Overflow protection switch

Refer to *Service* - Overflow protection switch for testing procedures.

6. (A) Level control board & level probe. (Electro/mechanical controlled)

Refer to *Service* - Level control board for testing procedures.

(B) Electronic controls

Refer to *Service* - Electronic controls for testing procedures.

TROUBLESHOOTING (cont.)

Problem	Probable Cause	Remedy
Beverage level will not adjust (Selector switch in any position)	1. Brew Selector switch	Refer to <i>Service</i> - Selector switch for testing procedures.
Water flows into tank continuously (On/Off Switch "OFF").	1. Solenoid valve	Refer to <i>Service</i> - Solenoid valve for testing procedures.
	2A. Level control board and level probe (Electro/mechanical)	Refer to <i>Service</i> - Level control board for test procedures.
	2B. Control assembly (Electronic)	Refer to <i>Service</i> - Control assembly for testing procedures.
Water flows into tank continuously (ON/OFF switch "ON").	3. Overflow protection switch	Refer to <i>Service</i> - Timer for testing procedures.
	1. Timer	Refer to <i>Service</i> - Overflow protection switch for testing procedures.
Water from tank is not hot	1. Limit thermostat	Refer to <i>Service</i> - Limit thermostat for testing procedures.
	CAUTION - Do not eliminate or bypass limit thermostat. Use only replacement part #23717.0001	
	2A. Control Thermostat (Electro/mechanical)	Refer to <i>Service</i> - Control Thermostat for testing procedures.
	2B. Control assembly (Electronic)	Refer to <i>Service</i> - Control assembly for testing procedure.
	3. Contactor (Brewers with Recovery Booster)	Refer to <i>Service</i> - Contactor for testing procedures.
4. Tank heaters	Refer to <i>Service</i> - Tank heaters for testing procedures.	
5. Triac assembly (Electronic)	Refer to <i>Service</i> - Triac assembly for testing procedures.	

TROUBLESHOOTING (cont.)

Problem	Probable Cause	Remedy
Water from tank is not hot (cont.).	6. Relay (Brewers with Recovery Booster)	Refer to <i>Service</i> - Relay for testing procedures.
Server warmer is not hot.	1. ON/OFF switch	Refer to <i>Service</i> - ON/OFF switch for testing procedures.
	2. Warmer element	Refer to <i>Service</i> - Warmer element for testing procedures.
Spitting or unusual steaming from sprayhead or airvents.	1A. Control thermostat (Electro/mechanical)	Refer to <i>Service</i> - Control thermostat for testing procedures.
	1B. Control assembly (Electronic)	Refer to <i>Service</i> - Control assembly for testing procedures.
	2. Triac assembly (Electronic)	Refer to <i>Service</i> - Triac assembly for testing procedures.
	3. Lime build-up	Inspect the tank assembly for excessive lime deposits. Delime as required.
Inconsistent beverage level in server.	CAUTION - Tank and tank components should be delimed regularly depending on local water conditions. Excessive mineral build-up on stainless steel surfaces can initiate corrosive reactions resulting in serious leaks.	
	1. Strainer/flow control	(A) Direction of flow arrow must be pointing towards the brewer. (B) Remove the strainer/flow control and check for obstructions. Clear or replace.
	2. Improper water pressure	Check operating water pressure to the brewer. It must be between 20 and 90 psi (138 and 620 kPa) .

TROUBLESHOOTING (cont.)

Problem	Probable Cause	Remedy
Inconsistent beverage level in server (cont.).	3. Dispense valve	Refer to <i>Service</i> - Dispense valve for testing procedures.
Consistently high or low beverage level in server.	1. Timer adjustment	Adjust the timer as required to achieve the recommended volume for each brew cycle.
Dripping from sprayhead.	1. Dispense valve	Refer to <i>Service</i> - Dispense valve for testing procedures.
Water overflows filter.	1. Bypass valve	Refer to Installation & Operating Guide, <i>Initial Set-Up</i> .
	2. Needle Valve	Refer to Installation & Operating Guide, <i>Initial Set-Up</i>
	3. Type of paper filters	BUNN paper filters should be used for proper extraction.
	4. No sprayhead	Check sprayhead
Beverage overflows server.	1. Beverage left in server	The brew cycle should be started only with an empty server under the funnel.
	2. Timer adjustment	Adjust the timer as required to achieve the recommended volume for each brew cycle. Refer to <i>Service</i> - Timer for testing procedures.
	3. Dispense valve	Refer to <i>Service</i> - Dispense valve for testing procedures.
Weak beverage.	1. Type of paper filters	BUNN paper filters should be used for proper extraction.
	2. Coffee	A sufficient quantity of fresh drip or regular grind should be used for proper extraction.

TROUBLESHOOTING (cont.)

Problem	Probable Cause	Remedy
Weak beverage (cont.)	3. Sprayhead	A clean sprayhead should be used to properly wet the bed of ground coffee in the funnel.
	4. Funnel loading	The BUNN paper filter should be centered in the funnel and the bed of ground coffee leveled by gentle shaking.
	5. Water temperature	Empty the server, remove its cover, and place the server on the warmer. Place empty funnel over the server entrance, with ON/OFF switch in the "ON" position press the start switch and release it. Check the water temperature immediately below the sprayhead with a thermometer. The reading should not be less than 195°F(91°C).
Brewer is making unusual noises.	1. Solenoid (Inlet)	The nut on back of the solenoid must be tight or it will vibrate during operation
	2. Plumbing lines	Plumbing lines should not be resting on the counter top.
	3. Water supply	(A) The brewer must be connected to a cold water line.
		(B) Water pressure to the brewer must not be higher than 90 psi (620 kPa). Install a regulator if necessary to lower the working pressure to approximately 50 psi (345 kPa).
	4. Tank Heater(s)	Remove and clean lime off tank heater(s).
5. Contactor	Check for low voltage	

TROUBLESHOOTING (cont.)

Problem	Probable Cause	Remedy
Server will not heat	1. Circuit breaker	A) Check and reset if necessary B) Refer to <i>Service</i> - Circuit breaker for test procedures.
	2. Receptacle Contacts	Clean or replace.
	3. Relay (Server Power) (Prior to S.N. DUAL026000)	Refer to <i>Service</i> - Relay (Soft Heat) for test procedures.
	4. Transformer	Refer to <i>Service</i> - Transformer for test procedures.
	5. Rectifier	Refer to <i>Service</i> - Rectifier for test procedures.

SERVICE

This section provides procedures for testing and replacing various major components used in this brewer should service become necessary. Refer to *Troubleshooting* for assistance in determining the cause of any problem. Illustrations shown are DUAL brewers with SINGLE brewers similar except where noted.

WARNING - Inspection, testing, and repair of electrical equipment should be performed only by qualified service personnel. The brewer should be unplugged when servicing, except when electrical tests are required and the test procedure specifically states to plug in the brewer.

COMPONENT ACCESS

WARNING - Unplug the brewer before the removal of any panel or the replacement of any component.

All components are accessible by the removal of the top cover, front access panel, warmer base plate and/or server platform cover. The covers and panels are attached with slotted head screws as follows:

SINGLE & SINGLE SH top cover	(1) #4-40
DUAL & DUAL SH top cover	(4) #4-40
SINGLE front access panel	(4) #6-32
SINGLE SH front access panel	(8) #6-32
DUAL front access panel	(5) #6-32
DUAL SH front access panel	(11) #6-32
SINGLE & DUAL warmer base	(4) #6-32
SINGLE SH & DUAL SH server platform	(4) #6-32

Contents

Brewer Selector Switch	12
Bypass Valve	11
Circuit Breakers.....	14
Contact Assembly	15
Control Thermostat.....	17
Dispense Valve.....	18
Grinder Selector Switch	20
Level Control Board and Level Probe	21
Limit Thermostat.....	23
Main Power Switch	45
ON/OFF Switch (Warmer).....	24
Overflow Protection Switch.....	25
Receptacle	26
Rectifiers.....	26
Relay	27
Solenoid.....	33
Start Switches (Brew)	35
Tank Heaters	36
Timers (Early Models).....	37
Digital Timer (Late Models).....	40
Transformers.....	42
Warmer Elements.....	44
Wiring Diagrams	46

SERVICE (cont.)

BYPASS VALVE

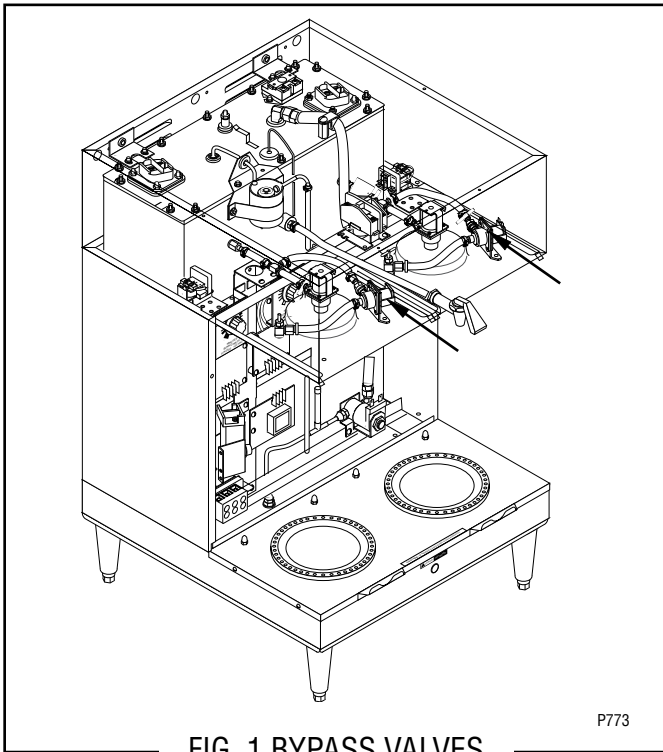

FIG. 1 BYPASS VALVES

Location:

The bypass valves are located on the sprayhead panel inside the hood.

Test Procedures:

1. Disconnect the brewer from the power source and place a server beneath the funnel.
2. Check the water level in the tank to confirm that it is within 1/2" from the top of the tank.
3. Connect the brewer to the power source.
4. Check the bypass valve for coil action. Place the ON/OFF switch in the "ON" position, press and release the BREW switch. Listen carefully in the vicinity of the bypass valve for a "clicking" sound as the coil magnet attracts and repels the plunger.
5. Disconnect the brewer from the power source.

If the sound is heard as described, there may be a blockage in the bypass valve or the water line to the sprayhead. Remove the bypass valve and inspect for wear, and remove waterborne particles.

If the sound is not heard as described, proceed to #6.

6. Connect the voltmeter lead ends to the bypass valve coil terminals. Connect the brewer to the power source. With the selector switch in the 1 or 1-1/2 gallon position, place "ON/OFF" Switch in the "ON" position. Press and release the brew switch. The indication must be:
 - a.) 120 volts ac for two wire 120 volt models, three wire 120/208 volt and three wire 120/240 volt models.
 - b.) 200 to 240 volts ac for two wire 200 or 240 volt models.

7. Disconnect the brewer from the power source.

If voltage is present as described, but no coil action is observed, nor "clicking" heard, bypass valve is defective. Replace valve and test again to verify repair.

If voltage is not present as described, refer to *Wiring Diagrams* and check the brewer wiring harness. Also check the control board for proper operation.

Removal and Replacement:

1. Remove the wires from the bypass valve.
2. Drain enough water from the tank so bypass valve is above the water line.
3. Remove water lines from bypass valve.
4. Remove the two nuts retaining the bypass valve inside the hood and remove bypass valve.
5. Remove hose barb fitting and attach to new bypass valve.
6. Install new bypass valve with hose barb fitting.
7. Reconnect the water tubes and the wires to the bypass valve.
8. Refer to Fig. 2 when reconnecting the wires.

NOTE: If one of the terminals is marked "1", connect WHI/GRN wire to it.

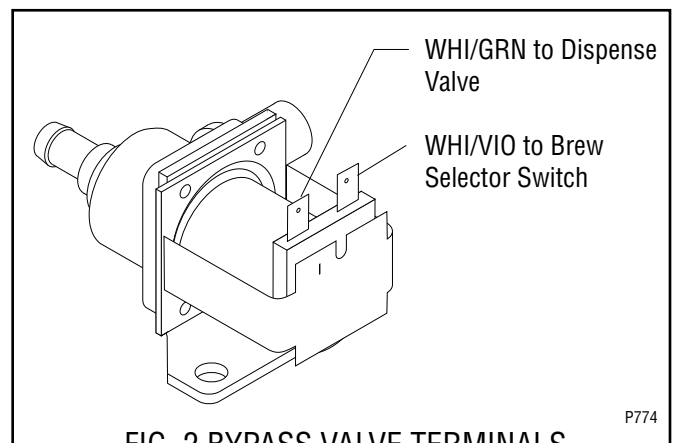

FIG. 2 BYPASS VALVE TERMINALS

SERVICE (cont.)

BREW SELECTOR SWITCH

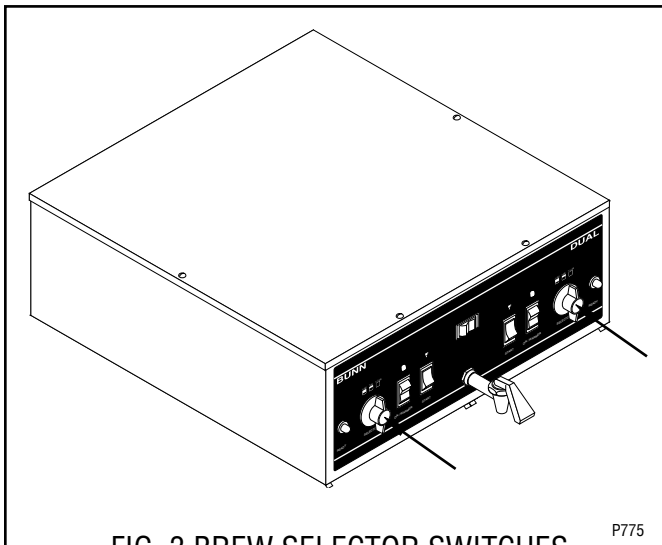

FIG. 3 BREW SELECTOR SWITCHES

Location:

The brew selector switch(es) are mounted in the front panel of the hood.

Test Procedure (Early model Selector Switch):

1. Disconnect the brewer from the power supply.
2. Separate the connector on the selector switch harness from the brew timer circuit board.
3. Carefully slide the plastic cover off of the connector from the switch harness.
4. Check for continuity across the pink and tan wires on the connector when the switch is in the small batch position. Continuity must not be present in any other switch position.
5. Check for continuity across the pink wire and gray wire when the switch is in the medium batch position. Continuity must not be present in any other position.
6. Reattach the connector to the brew timer circuit board.
7. Disconnect the gray wire from the left or right selector switch and gray wire from the interface socket.
8. Check for continuity across the gray wires.
9. Reconnect the gray wires from the selector switches and the interface socket.
10. Disconnect the pink wire from the left or right selector switch to the grinder switch.
11. Check for continuity across the pink wire and the terminal on the grind switch.

12. Reconnect the pink wire to the grind switch.
13. Disconnect the tan wire from the left or right selector switch and tan wire from interface socket.
14. Check for continuity across the tan wires.
15. Reconnect the tan wires.
16. With the selector switch set at the medium and large batch positions, disconnect the white/violet from the bypass valve.
17. Check for continuity across the white/violet wire and terminal on bypass valve.
18. Reconnect the white/violet wire to the terminal on the bypass valve.
19. Disconnect the white/red wire from the dispense valve.
20. Check for continuity across white/red wire and terminal on dispense valve.
21. Reconnect white/red wire to the terminal on the dispense valve.

If continuity is present as described the switch is operating properly.

If continuity is not present as described replace switch assembly.

Removal and Replacement:

1. Disconnect the connector on the selector switch harness from the brewer timer circuit board.
2. Disconnect wires from the selector switch, interface socket, dispense valve and bypass valve.
3. Loosen the set screw on the switch knob.
4. Remove the 9/16" nut and washer holding the switch to the hood.
5. Remove the switch.
6. Install the new switch. The positioning tab must be in the hole in the hood for proper switch and knob alignment.
7. Install the knob so that the arrow lines up in the large batch position when the switch is turned to the full right position.
8. Reattach the connector to the brew timer circuit board.
9. Refer to Fig. 4 when reconnecting the wires.

SERVICE (cont.)

BREW SELECTOR SWITCH (cont.)

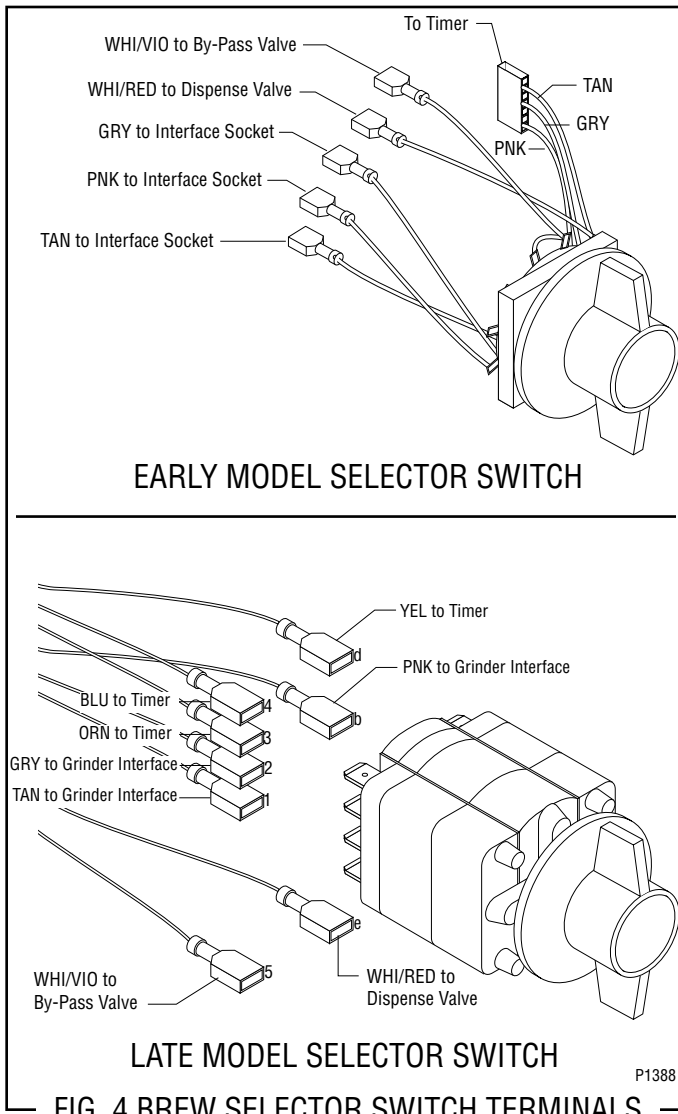

5. Check for continuity across terminals (e) and (5). When the selector switch is in the small batch position, continuity should not be present. When the selector switch is in the medium or large batch positions, continuity should be present.

If continuity is present as described the switch is operating properly.
If continuity is not present as described replace switch assembly.

Removal and Replacement:

1. Disconnect all wires from the brew selector switch.
2. Loosen the set screw on the switch knob.
3. Remove the 9/16" nut and washer holding the switch to the hood.
4. Remove the switch.
5. Install the new switch. The positioning tab must be in the hole in the hood for proper switch and knob alignment.
6. Install the knob so that the arrow lines up in the large batch position when the switch is turned to the full right position.
7. Refer to Fig. 4 when reconnecting the wires.

Test Procedure (Late model Selector Switch):

1. Disconnect the brewer from the power supply.
2. Disconnect all wires from the brew selector switch.
3. Check for continuity across terminals (b) and (1) when the switch is in the small batch position. Continuity must not be present in any other switch position.
4. Check for continuity across terminals (b) and (2) when the switch is in the medium batch position. Continuity must not be present in any other position.

SERVICE (cont.)

CIRCUIT BREAKERS

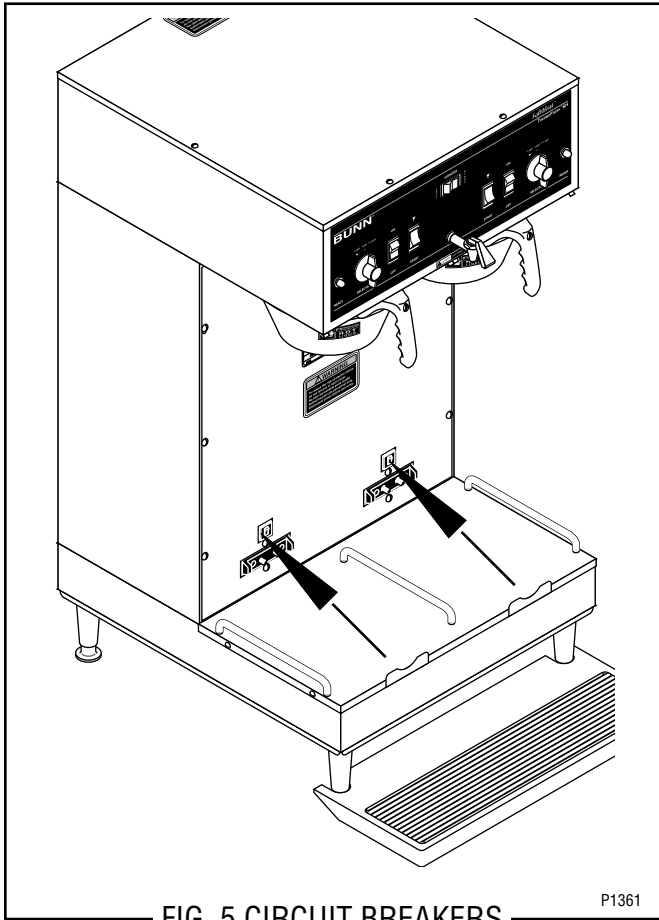

FIG. 5 CIRCUIT BREAKERS
(SH Brewers only)

P1361

Removal and Replacement:

1. Remove the wires from the circuit breaker.
2. Compress the clips on the back side of the server platform and gently push the circuit breaker through the opening in the server platform.
3. Push the new circuit breaker into the opening in the server platform until the clips snap into position.
4. Reconnect the wires to the circuit breaker.
5. Refer to Fig. 6 when reconnecting the wires.

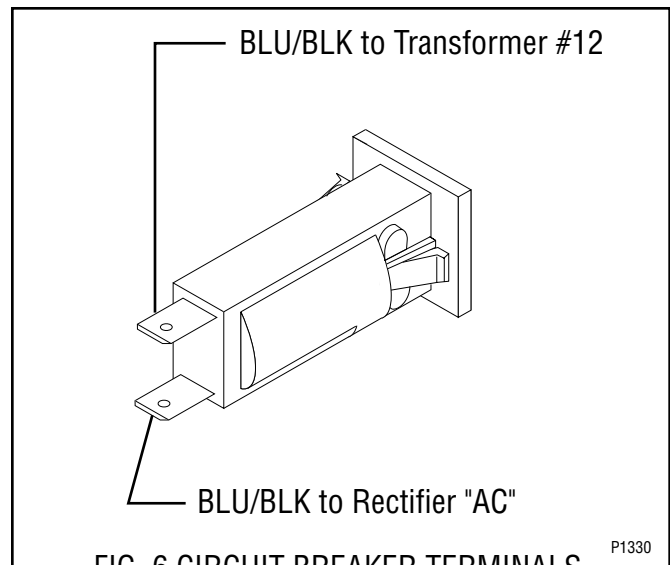

FIG. 6 CIRCUIT BREAKER TERMINALS

P1330

Location

The circuit breakers are located on the lower front of the brewer, mounted on the server platform just above the spring contact receptacle assembly.

Test Procedures:

1. Disconnect the dispenser from the power source.
2. Remove the wires from the circuit breaker.
3. Check for continuity between the terminals. Continuity must be present between the terminals.

If continuity is present as described the circuit breaker is functioning properly.

If continuity is not present as described, press reset button and repeat step #3, if continuity is not present as described, replace the circuit breaker.

SERVICE (cont.)

CONTACTOR ASSEMBLY

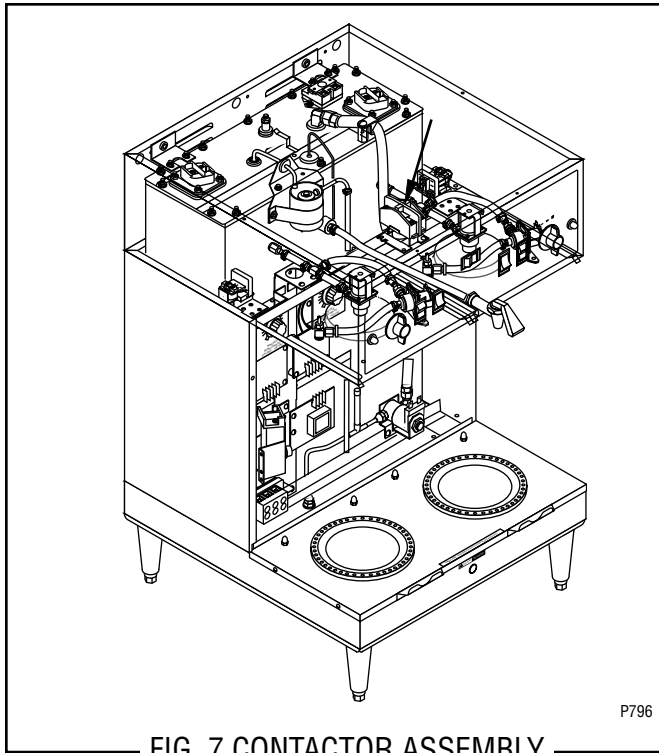

FIG. 7 CONTACTOR ASSEMBLY

Location:

The contactor assembly is located inside the hood just to the rear of the dispense valve (Right side for DUAL and DUAL SH models).

Test Procedures:

Mechanical Thermostat (Brewers with or without Recovery Booster)

1. Disconnect the brewer from the power source.
2. Disconnect the white wire of the two pole 120V terminal block, white wire of the three pole 120/208V or 120/240V or the red wire of the two pole 200V or 240V terminal block and the black wire of the contactor coil. Disconnect the black wire of the control thermostat from the remaining black wire of the contactor coil.
3. Gently remove the capillary bulb and grommet from the tank.
4. With a voltmeter, check the voltage across the white wire from the terminal block on 120, 120/208, 120/240 volt units or the red wire from 200 or 240 volt units and the black wire from the control thermostat when the thermostat is turned clockwise to the "FULL ON" position. Connect the brewer to the power source. The indication must be:
 - a.) 120 volts ac for two wire 120 volt models, three

wire 120/208 volt models and three wire 120/240 volt models.

b.) 200 to 240 volts ac for two wire 200 or 240 volt models.

5. Disconnect the brewer from the power source.

If voltage is present as described, proceed to #6. If voltage is not present as described, refer to the *Wiring Diagrams* and check the brewer wiring harness.

6. Check for continuity between the two black wires of the contactor coil.

If continuity is present as described, reconnect one black wire to red or white wire from the terminal block and the other black wire to the black wire from the control thermostat. Reinstall capillary tube into the tank to a line 7" above the bulb and proceed to #7. If continuity is not present as described, replace the contactor.

7. Locate the white wire or red wire on L1 terminal and black wire on the L2 terminal on the contactor.
8. With a voltmeter, carefully check the voltage across the white or red and black wires. The indication must be:
 - a.) 120 volts ac for two wire 120 volt models, 208 volts ac for three wire 120/208 volt models and 240 volts ac for three wire 120/240 volt models.
 - b.) 200 to 240 volts ac for two wire 200 or 240 volt models.
9. Disconnect the brewer from the power source.

If voltage is present as described, proceed to #10. If voltage is not present as described, refer to the *Wiring Diagrams* and check brewer wiring harness.

10. Check for continuity across the terminals on the left side of the contactor by manually closing the contacts. Continuity must not be present when the contact is released.
11. Check for continuity across the terminals on the right side of the contactor by manually closing the contacts. Continuity must not be present when the contact is released.

If continuity is present as described, the contactor is operating properly.

SERVICE (cont.)

CONTACTOR ASSEMBLY (cont.)

If continuity is not present as described, replace the contactor.

Test Procedures :

Electronic Control (Brewers w/Recovery Booster)

1. Disconnect the brewer from the power source.
2. Disconnect the gray wire from the black wire on the rear of the contactor coil and white/brown wire from the black wire on the front of the contactor coil.
3. With a voltmeter, check the voltage across the gray wire and white/brown wire with both "ON/OFF" switches in the "ON" position. Connect the brewer to the power source and press both start switches. The indication must be:
 - a.) 120 volts ac for three wire 120/208 volt models and three wire 120/240 volt models.
 - b.) 200 to 240 volts ac for two wire 200 or 240 volt models.
4. Disconnect the brewer from the power source.

If voltage is present as described, proceed to #5.

If voltage is not present as described, refer to the *Wiring Diagrams* and check brewer wiring harness.

5. Disconnect the blue and red wires from the contactor terminals. Check for continuity across the terminals of the contactor by manually closing the contacts. Continuity must not be present when the contact is released.

If continuity is present as described, reconnect the blue and red wires to the contactor terminals. Connect one black lead from the contactor coil to the gray wire and the white/brown wire to the remaining black lead of the contactor coil. The contactor is operating properly.

If continuity is not present as described, replace the contactor.

Removal and Replacement:

1. Remove all wires from the contactor.
2. Remove the two #10-32 slotted head screw securing contactor to the inside of the hood.

3. Securely install the new contactor inside the hood.
4. Refer to Fig. 8 when reconnecting the wires.

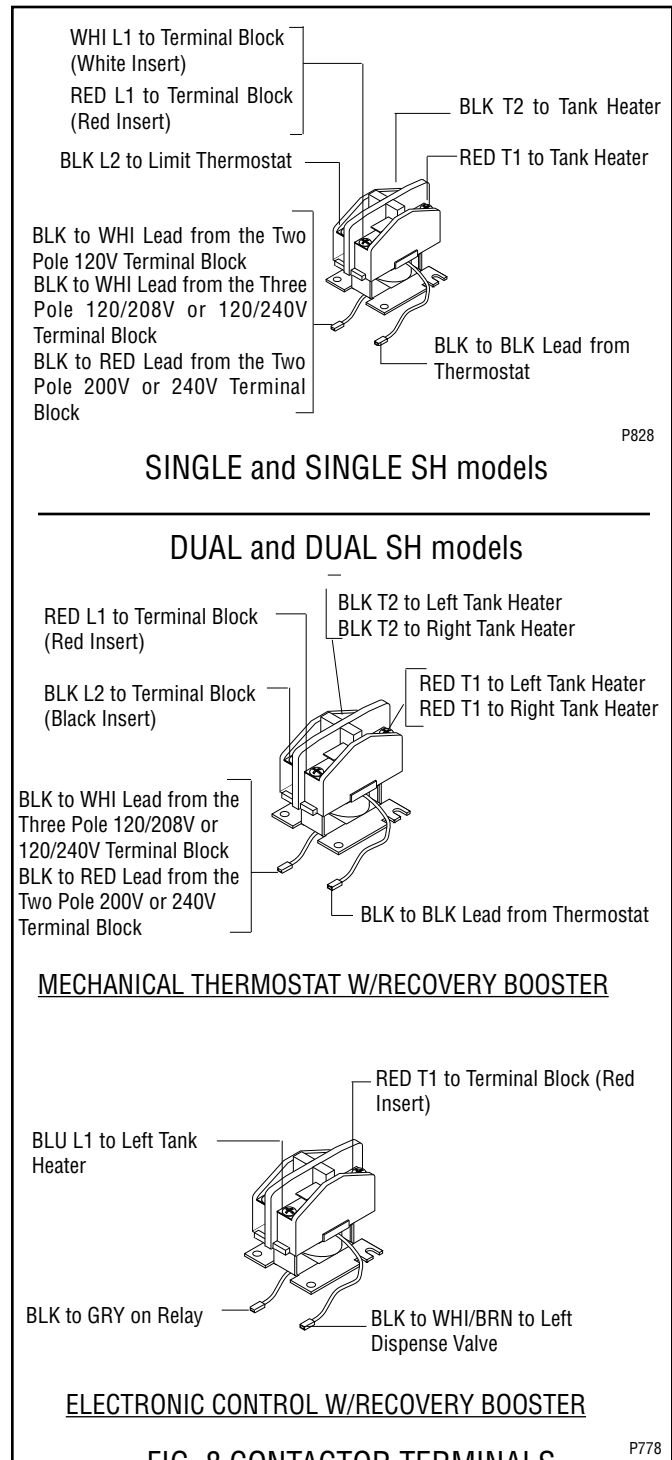

FIG. 8 CONTACTOR TERMINALS

SERVICE (cont.)

CONTROL THERMOSTAT

Location:

The control thermostat is located inside the lower left front of the brewer on the component bracket.

1. Disconnect the brewer from the power source.
2. Locate the blue wire on the control thermostat.
3. With a voltmeter, check the voltage across the blue wire on the control thermostat and the white insert on the two or three pole 120V, 120/208V, 120/240V terminal block and the red insert on two pole 200V, 240V terminal block. Connect the brewer to the power source. The indication must be:
 - a.) 120 volts ac for two wire 120V models, three wire 120/208 volt models and three wire 120/240 volt models.
 - b.) 200 to 240 volts ac for two wire 200 or 240 volt models.
4. Disconnect the brewer from the power source.

If voltage is present as described, proceed to #5.
If voltage is not present as described, refer to the *Wiring Diagrams* and check brewer wiring harness.

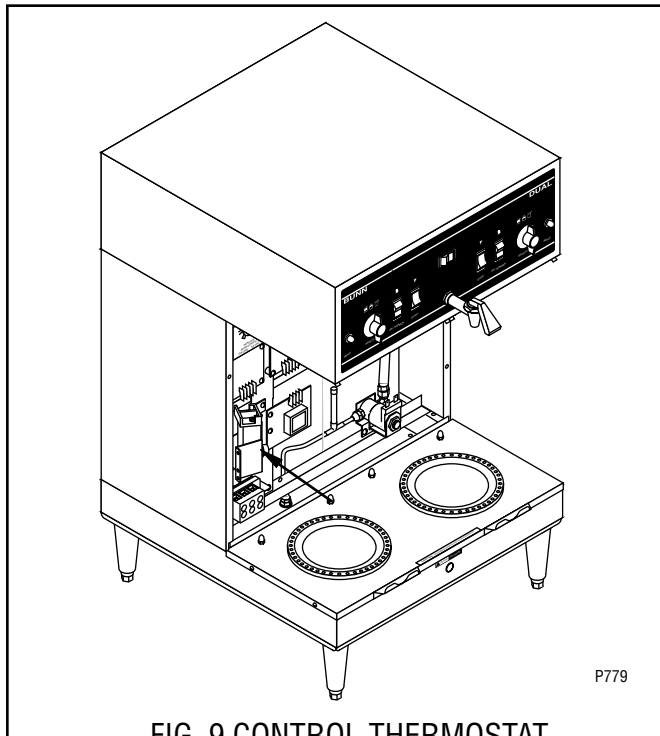

FIG. 9 CONTROL THERMOSTAT

5. Locate the black wires from the control thermostat.
6. Gently remove the capillary bulb and grommet from the tank.
7. With a voltmeter, check the voltage across the black wires of the control thermostat and the white insert on the two pole or three pole 120V, 120/208V, 120/240V terminal blocks and the red insert on two pole 200V, 240V terminal blocks when the control thermostat is turned "ON" (fully clockwise). Connect the brewer to the power source. The indication must be:
 - a.) 120 volts ac for two wire 120V models, three wire 120/208 volt models and three wire 120/240 volt models.
 - b.) 200 to 240 volts ac for two wire 200 or 240 volt models.Voltage must not be indicated across these terminals when the thermostat is turned "OFF" (fully counterclockwise).
8. Disconnect the brewer from the power source.

If voltage is present as described, reinstall the capillary tube into the tank to the line 7" above the bulb, the control thermostat is operating properly.

If voltage is not present as described, replace the thermostat.

Removal and Replacement:

1. Remove wires from the control thermostat.
2. Remove the thermostat capillary bulb by firmly pulling up on the capillary tube at the tank lid. This will disengage the grommet from the tank lid.
3. Remove the #8-32 slotted head screw holding the control thermostat to the component bracket.
4. Slide the grommet to the line 7" above the bulb on the new capillary tube.
5. Insert the capillary bulb through the hole in the tank lid and press the grommet firmly and evenly so that the groove in the grommet fits into the tank lid.
6. Carefully bend the capillary tube so that the tube and bulb inside the tank are in the vertical position.

SERVICE (cont.)

CONTROL THERMOSTAT (cont.)

NOTE - The capillary tube must be clear of any electrical termination and not kinked.

7. Using a #8-32 slotted head screw fasten the control thermostat to the component bracket.
8. Refer to Fig. 10 when reconnecting the wires.
9. Adjust the control thermostat as required.

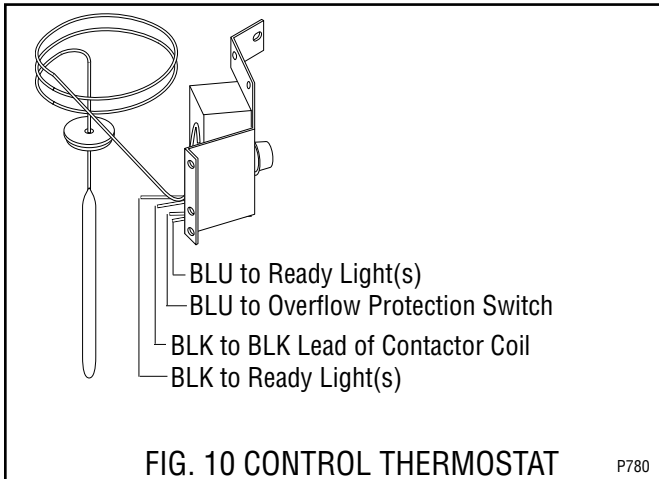

DISPENSE VALVE

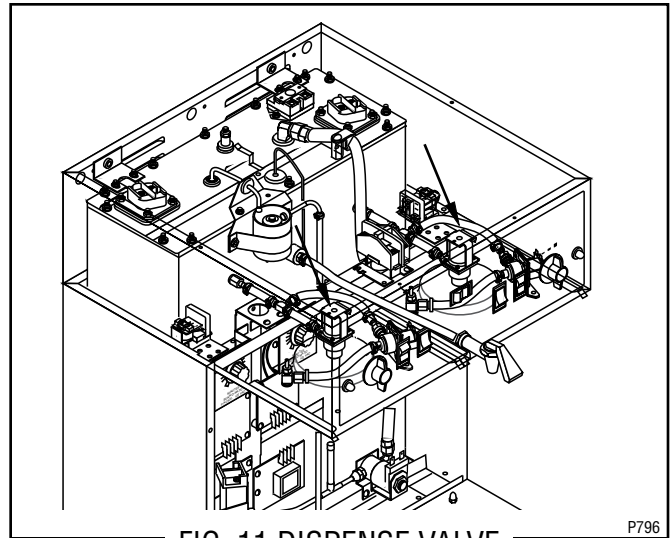

Location:

Dispense valves are located inside the hood in the center of each sprayhead panel.

Test Procedures:

1. Disconnect the brewer from the power source.
2. Disconnect the wires from the right dispense valve and check the voltage across the white/violet wire and white/green wire. Connect brewer to the power source. Place the "ON/OFF" switch in the "ON" position, press and release the start switch. The indication must be:
 - a.) 120 volts ac for two wire 120V models, three wire 120/208 volt models and three wire 120/240 volt models.
 - b.) 200 to 240 volts ac for two wire 200 or 240 volt models.
3. Disconnect brewer from the power source.
4. Disconnect the wires from the left dispense valve and check voltage across the white/red wire and the white/brown wire. Connect the brewer to the power source. Place the "ON/OFF" switch in the "ON" position and press and release the start switch. The indication must be:
 - a.) 120 volts ac for two wire 120V models, three wire 120/208 volt models and three wire 120/240 volt models.
 - b.) 200 to 240 volts ac for two wire 200 or 240 volt models.
5. Disconnect brewer from power source.

SERVICE (cont.)

DISPENSE VALVE (cont.)

If voltage is present as described in steps 2 & 4 proceed to #6.

If voltage is not present as described, refer to the *Wiring Diagrams* and check brewer wiring harness.

6. Check for continuity across the dispense valve coil terminals.

If continuity is present as described, reconnect the wires to the dispense valve and proceed to #7

If continuity is not present as described, replace the dispense valve.

7. Check the dispense valve for coil action. Connect the brewer to power source. Place the ON/OFF switch in the "ON" position, press and release the start switch. Listen carefully in the vicinity of the dispense valve for a "clicking" sound as the coil magnet attracts and repels the plunger.
8. Disconnect the brewer from the power source.

If the sound is heard as described, there may be a blockage in the dispense valve or the water line to the dispense valve. Remove the dispense valve and inspect for wear, and remove waterborne particles.

If the sound is not heard as described, replace the dispense valve.

Removal and Replacement:

1. Disconnect wires and water tubes from dispense valve.
2. Drain enough water from the tank so the dispense valves are above the water line.
3. Remove dispense valve from the sprayhead panel.
4. Install new dispense valve.
5. Reconnect the water lines and the wires to the dispense valve.
6. Refer to Fig. 12 when reconnecting wires.

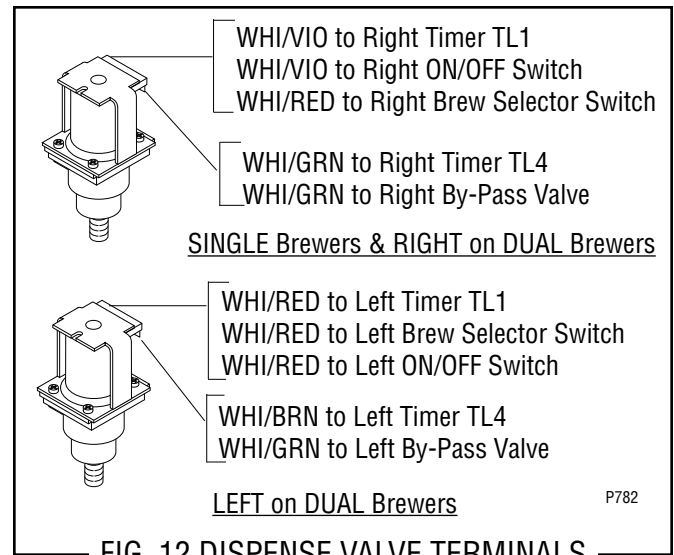

FIG. 12 DISPENSE VALVE TERMINALS

SERVICE (cont.)

GRINDER SELECTOR SWITCH

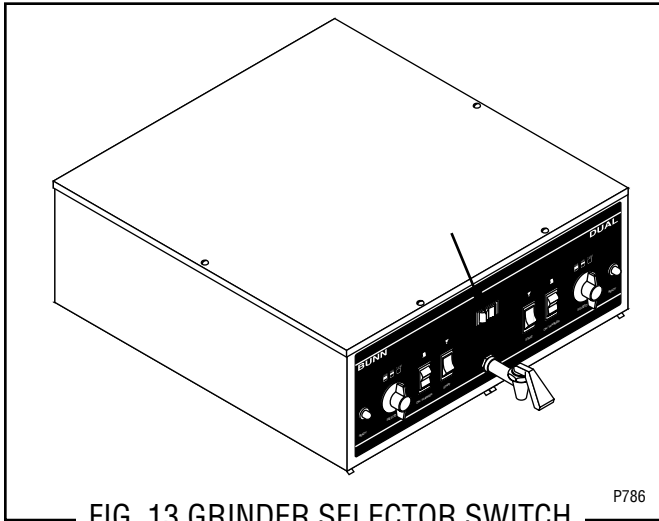

FIG. 13 GRINDER SELECTOR SWITCH
(DUAL and DUAL SH BREWERS only)

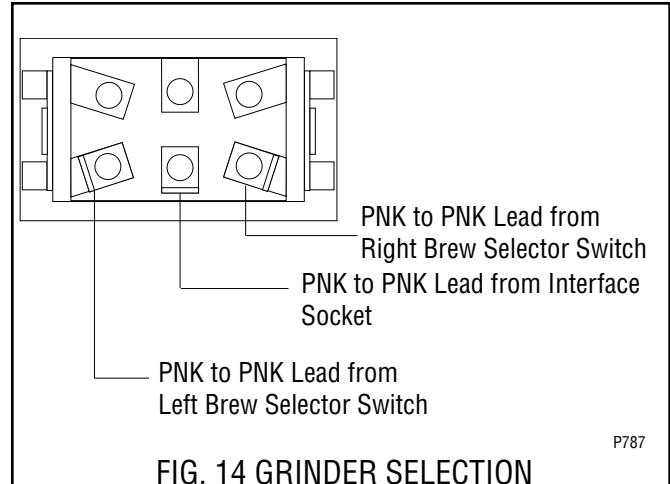

FIG. 14 GRINDER SELECTION
SWITCH TERMINALS

P787

Location:

The grinder selector switch is located in the upper center on the front of the hood.

Test Procedure:

1. Disconnect the brewer from the power source.
2. Remove all wires from the switch terminals.
3. Place the selector switch in the left position.
4. Check for continuity across the center and right terminals on the rear of the switch.
5. Continuity must not be present across the center and left terminals on the rear of the switch.
6. Check the bottom row, then the top row of terminals.

If continuity is present as described proceed to #7.

If continuity is not present as described replace the switch.

7. Place the selector switch in the right position.
8. Check for continuity across the center and left terminals on the rear of the switch.
9. Continuity must not be present across the center and right terminals on the rear of the switch.
10. Check the bottom row, then the top row.

If continuity is present as described, reconnect the wires, the switch is operating properly.

If continuity is not present as described, replace the switch.

11. Refer to Fig. 14 when reconnecting the wires.

SERVICE (cont.)

LEVEL CONTROL BOARD AND LEVEL PROBE (Electro/mechanical only)

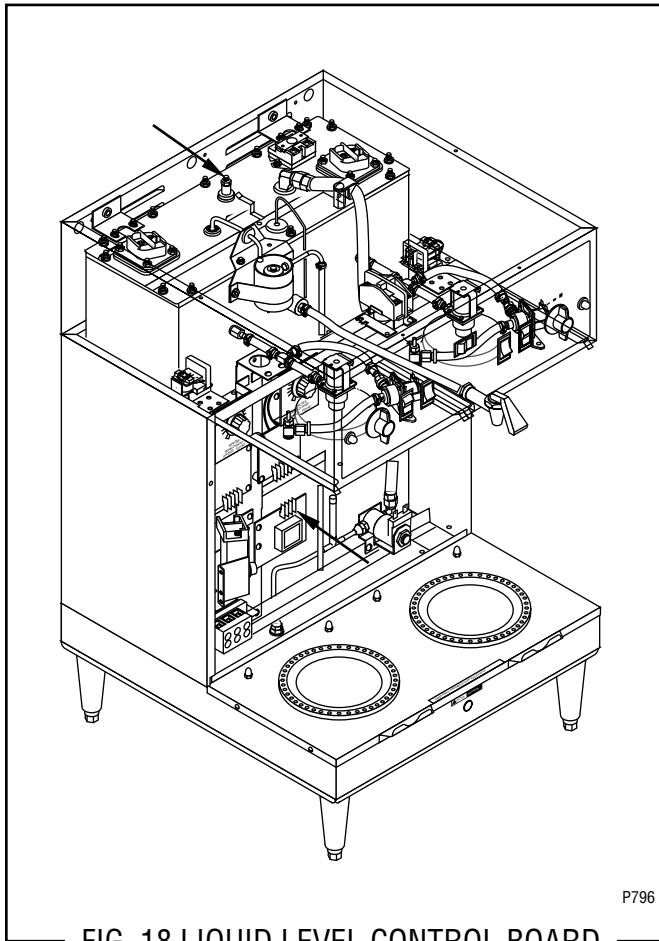

FIG. 18 LIQUID LEVEL CONTROL BOARD

Location:

The level control board is located inside the front of the brewer just left of center on the component bracket

Test Procedure:

1. Disconnect the brewer from the power source.
2. Remove the violet wire from terminal 1 & pink wire from terminal 4 of the circuit board.
3. With a voltmeter, check the voltage across terminals 2 & 3. Connect the brewer to the power source. The indication must be:
 - a.) 120 volts ac for two wire 120 volt models, three wire 120/208 volt models and three wire 120/240 volt models.
 - b.) 200 to 240 volts ac for two wire 200 or 240 volt models.
4. Disconnect the brewer from the power source.

If voltage is present as described, proceed to #5.

If voltage is not present as described, refer to the *Wiring Diagrams* and check brewer wiring harness.

5. Reconnect the violet wire to terminal 1.
6. Carefully connect a piece of insulated jumper wire to terminal 4. Keep the other end of this wire away from any metal surface of the brewer.
7. With a voltmeter, check the voltage across terminals 1 & 3. Connect the brewer to the power source. The indication must be:
 - a.) 120 volts ac for two wire 120 volt models, three wire 120/208 volt models and three wire 120/240 volt models after a delay of approximately 1 second.
 - b.) 200 to 240 volts ac for two wire 200 or 240 volt models after a delay of approximately 1 second.
8. Touch the free end of jumper wire to the brewer housing. The indication must be 0.
9. Move the jumper wire away from the brewer housing. The indication must again be:
 - a.) 120 volts ac for two wire 120 volt models, three wire 120/208 volt models and three wire 120/240 volt models after a delay of approximately 1 second.
 - b.) 200 to 240 volts ac for two wire 200 or 240 volt models after a delay of approximately 1 second.
10. Disconnect the brewer from the power source and remove the jumper wire from terminal 4.

If voltage is present as described, the level control board is operating properly, proceed to #11.

If voltage is not present as described, replace the level control board.

11. Reconnect the pink wire to terminal 4.
12. Gently pull the probe out of the tank lid and inspect for corrosion. Replace it if necessary.
13. Place the probe so that neither end is in contact with any metal surface of the brewer.
14. With a voltmeter, check the voltage across terminals 1 & 3. Connect the brewer to the power source. The indication must be:
 - a.) 120 volts ac for two wire 120 volt models, three wire 120/208 volt models and three wire 120/240 volt models after a delay of approximately 1 second.

SERVICE (cont.)

LEVEL CONTROL BOARD AND LEVEL PROBE (cont.)

- b.) 200 to 240 volts ac for two wire 200 or 240 volt models after a delay of approximately 1 second.
15. Move the probe's flat end to the brewer housing. The indication must be 0.
 16. Move the probe's flat end away from the brewer housing. The indication should again be:
 - a.) 120 volts ac for two wire 120 volt models, three wire 120/208 volt models and three wire 120/240 volt models.
 - b.) 200 to 240 volts ac for two wire 200 or 240 volt models.
 17. Disconnect the brewer from the power source.

If voltage is present as described, reinstall the probe, the level control board and level probe are operating properly.

If voltage is not present as described, check the pink probe wire.

Removal and Replacement:

1. Remove all wires from the level control board.
2. Remove two #8-32 slotted head screws holding level control board to component bracket.
3. Install the new level control board to the component bracket. Make certain that the lockwashers are between the level control board and the component bracket.
4. Refer to Fig. 19 when reconnecting the wires.

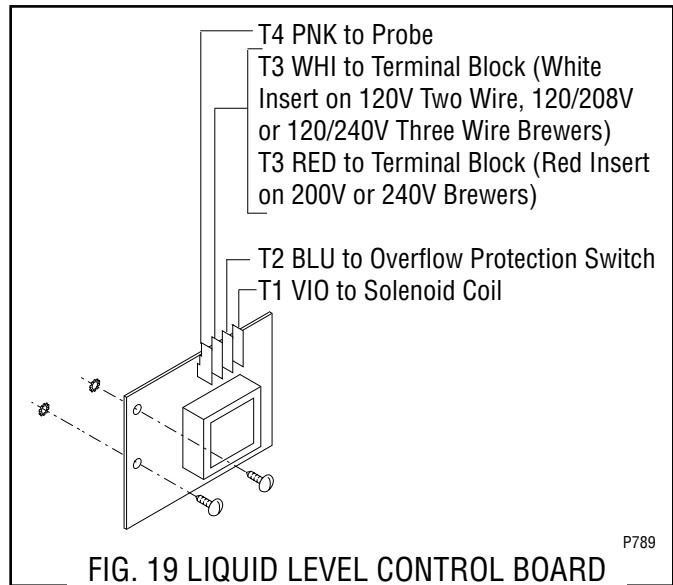

FIG. 19 LIQUID LEVEL CONTROL BOARD
TERMINALS

SERVICE (cont.)

LIMIT THERMOSTAT

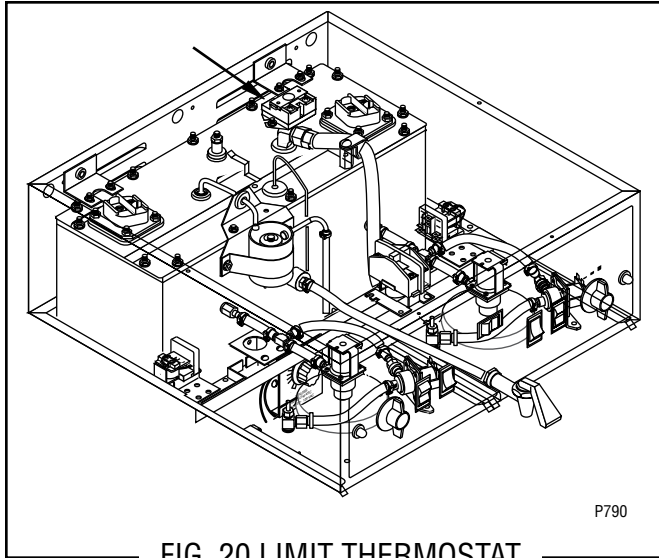

FIG. 20 LIMIT THERMOSTAT

Location:

The limit thermostat is located inside the hood on the tank lid just to the left of the right tank heater.

Test Procedure:

1. Disconnect the brewer from the power supply.
2. Disconnect the black wire from the limit thermostat to the terminal block.
3. With a voltmeter, check the voltage across the black wire removed from the limit thermostat and the black wires to the tank heater terminals.
4. Connect the brewer to the power supply.
5. The indication must be:
 - a.) 120 volts ac for two wire 120 volt models, three wire 120/208 volt models and three wire 120/240 volt models.
 - b.) 200 to 240 volts ac for two wire 200 or 240 volt models.
6. Disconnect the brewer from the power supply.

If voltage is present as described, reconnect the black wire to the limit thermostat from the terminal block, the limit thermostat is operating properly.

If voltage is not present as described, refer to the *Wiring Diagrams* and check brewer wiring harness.

Removal and Replacement:

1. Remove all wires from the limit thermostat terminals.
2. Carefully remove the two #8-32 nuts securing the limit thermostat to tank lid and remove limit thermostat.
3. Carefully secure new limit thermostat to tank lid.
4. Refer to Fig. 21 when reconnecting the wires.

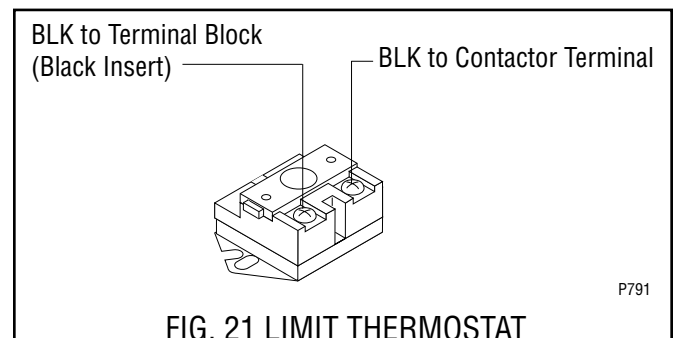

FIG. 21 LIMIT THERMOSTAT
TERMINALS

SERVICE (cont.)

ON/OFF SWITCH (Warmers)

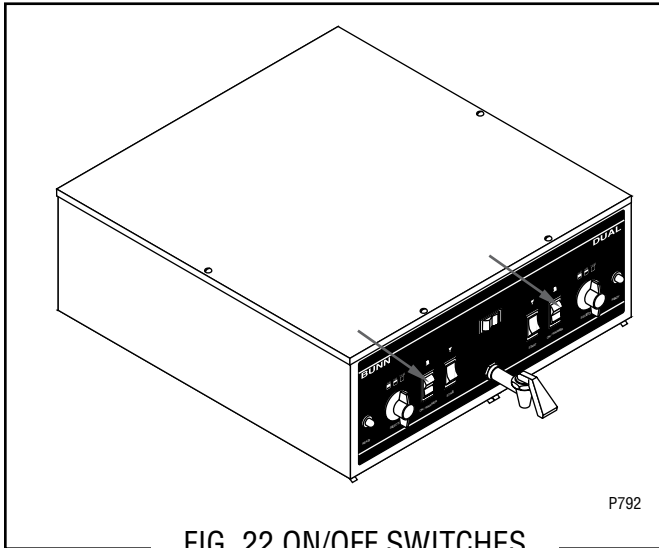

FIG. 22 ON/OFF SWITCHES

Location:

The ON/OFF switch(es) are located on the front of the hood next to the start switch(es).

Test Procedure:

1. Disconnect the brewer from the power source.
2. Viewing the switch from the back remove the white or red wire from the upper right terminal and the black wire from the center terminal.
3. With a voltmeter, check the voltage across the white wire and the black wire or red and black wire. Connect the brewer to the power source. The indication must be:
 - a.) 120 volts ac for two wire 120 volt models, three wire 120/208 volt models and three wire 120/240 volt models.
 - b.) 200 to 240 volts ac for two wire 200 or 240 volt models.
4. Disconnect the brewer from the power source.

If voltage is present as described, reconnect the white or the red wire, and proceed to #5.

If voltage is not present as described, refer to the *Wiring Diagrams* and check the brewer wiring harness.

5. With the black wire removed, remove the white/red wire on the left switch or the white/violet wire on the right switch from the lower left terminal.
6. Check for continuity across the center and lower left terminal with switch in the "ON" position.

Continuity must not be present when switch is in the "OFF" position.

If continuity is present as described, reconnect the black wire to the center terminal and the white/red wire on the left switch or the white/violet on the right switch to the lower left terminal.

If continuity is not present as described, replace the switch.

Removal and Installation:

1. Remove the wires from the switch terminals.
2. Compress the clips inside the hood and gently push the switch through the opening.
3. Push the new switch into the opening and spread the clips to hold switch in the hood.
4. Refer to Fig. 23 when reconnecting the wires.

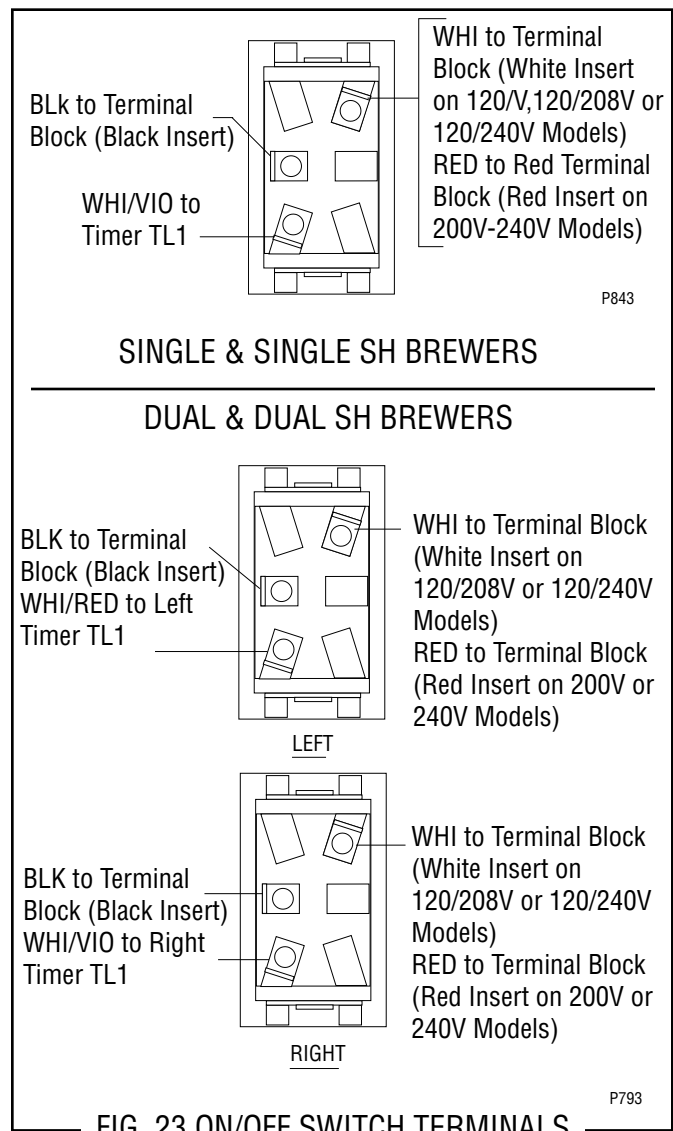
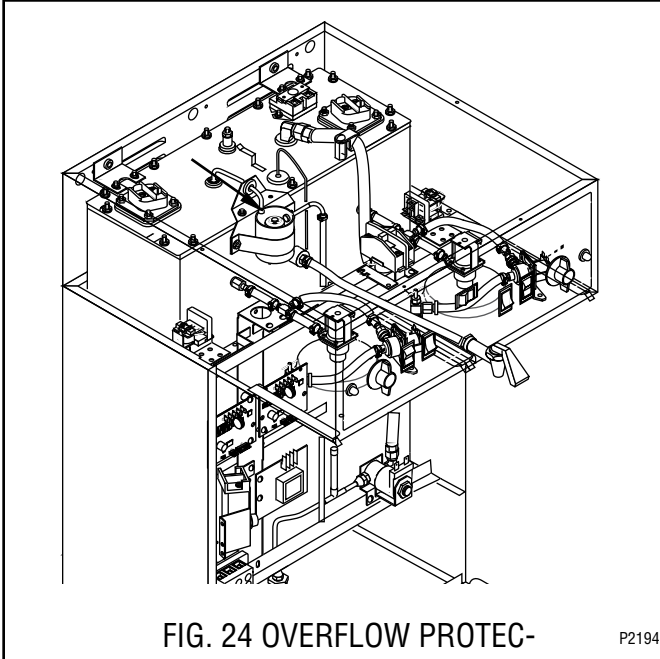

FIG. 23 ON/OFF SWITCH TERMINALS

SERVICE (cont.)

OVERFLOW PROTECTION SWITCH



Location:

The overflow protection switch is located inside the hood on the tank inside the copper overflow cup.

To test the overflow protection switch, access will also be needed to the level control board or electronic control assembly and terminal block.

Test Procedure:

1. Disconnect the brewer from the power source.
2. Remove the wire nuts connecting the red wires from the overflow protection switch to the black wire from the terminal block and blue wire from the thermostat or the black and red wires from the electronic control assembly.
3. Check for continuity across the overflow protection switch red wires only until the plastic float is raised and check that continuity returns when the plastic float is again lowered.

If continuity is present as described, reconnect the red wires to the blue wire from the thermostat and Liquid Level Control and the black wire from terminal block or black and red wires from electronic control assembly.

If continuity is not present as described, replace the

overflow protection switch.

Removal and Replacement:

1. Disconnect the red leads from the overflow protection switch from the blue wire from the thermostat and the black wire from the terminal block or black and red wires from electronic control assembly.
2. Remove the nut beneath the copper overflow cup.
3. Remove the entire switch assembly from the cup.
4. Place the new switch assembly into the cup, wires first. Make sure that the gasket is in place around the threaded switch stem.

NOTE - The magnets must be at the top of float and there must be NO adjusting washers installed for the overflow protection switch to operate properly.

5. Install the nut beneath the copper overflow cup. Be sure not to overtighten.
6. Refer to Fig. 25 when reconnecting wires.

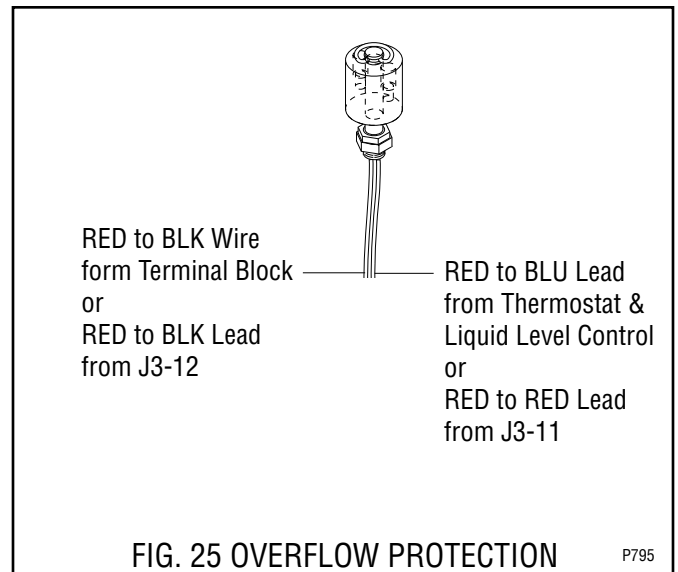

SERVICE (cont.)

RECEPTACLE ASSEMBLIES (SH Brewers only)

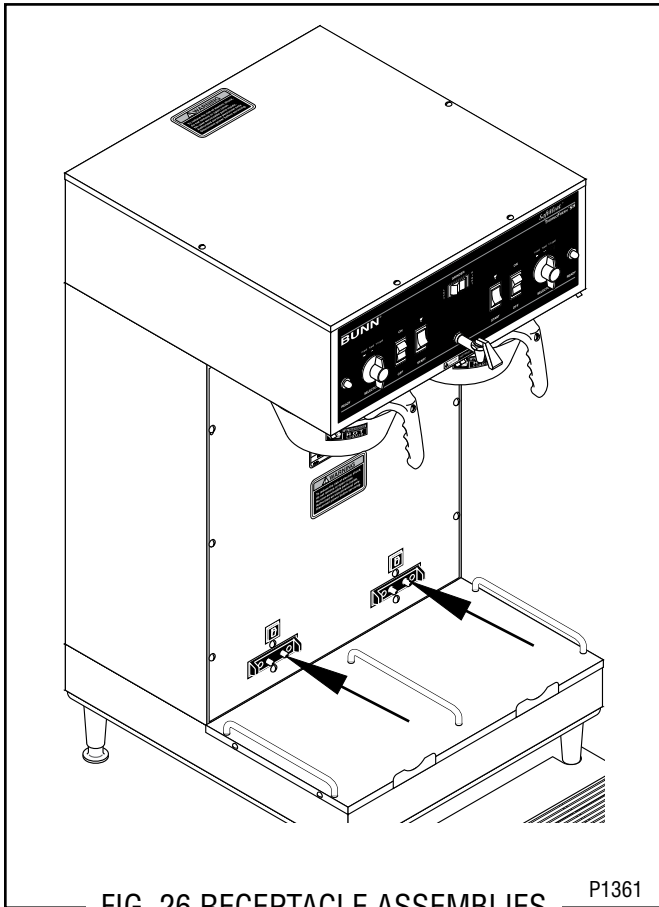

FIG. 26 RECEPTACLE ASSEMBLIES

P1361

Location:

The receptacle assemblies are located on the lower front of the brewer mounted on the server platform. Only one used on Single SH Brewers.

Test Procedures:

1. Clean or replace spring contacts.

Removal and Replacement:

1. Disconnect the brewer from the power source.
2. Disconnect the wires from the receptacle assembly.
3. Remove the two #6-32 flat head screws securing the receptacle to the server platform.
4. Remove and discard receptacle.
5. Install new receptacle in the server platform and secure two #6-32 flat head screws..
6. Refer to Fig. 27 and reconnect the wires.

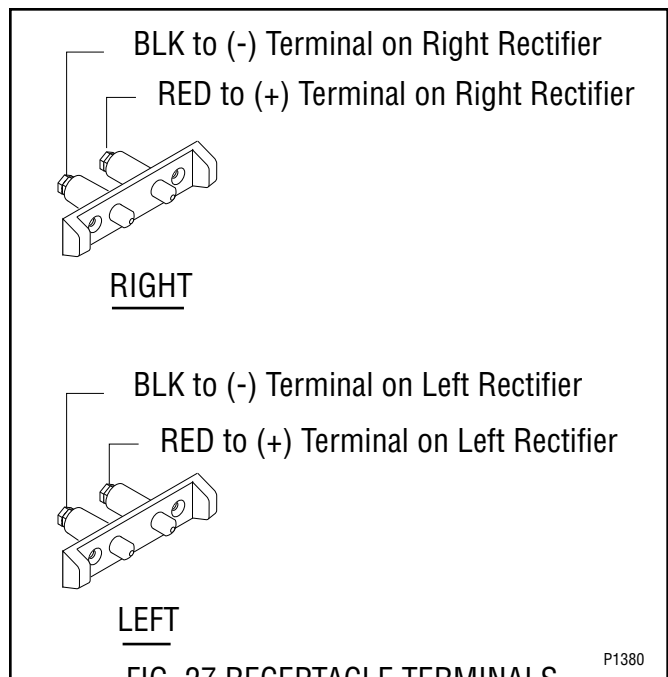

FIG. 27 RECEPTACLE TERMINALS

P1380

RECTIFIERS (SH Brewers only)

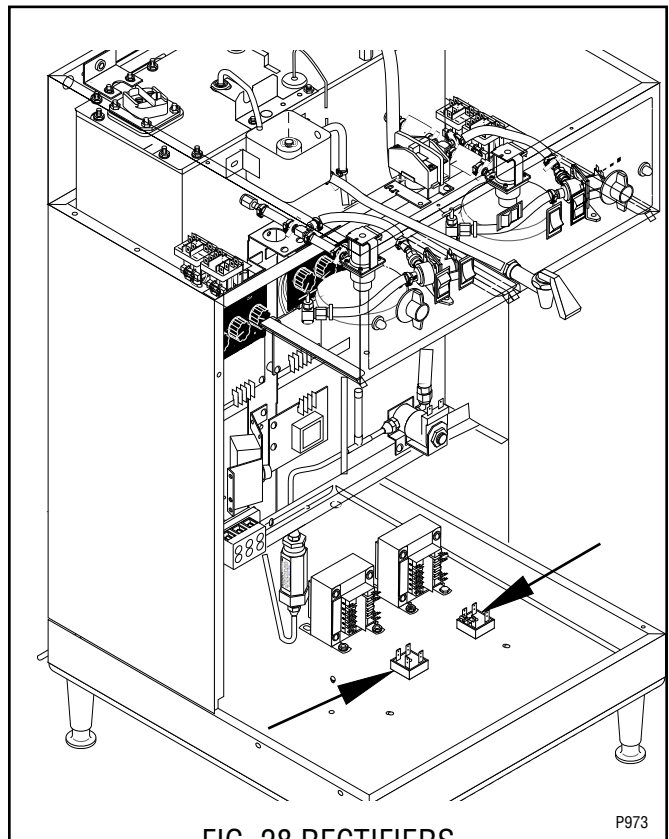

FIG. 28 RECTIFIERS

P973

Location:

The rectifiers are located inside the base housing on the right side of the base plate just in front of the transformers. Only one used on Single SH Brewers.

SERVICE (cont.)

RECTIFIERS (cont.)

Test Procedures:

1. Disconnect the brewer from the power source;
2. Remove the red wire and the black wire from the rectifier to be tested.
3. With a voltmeter check the voltage across the (+) and (-) terminals on the rectifier. Connect the brewer to the power source. The indication must be 24 volts dc.
4. Disconnect the brewer from the power source.

If voltage is present as described, the rectifier is operating properly.

If voltage is not present as described, refer to the brewer wiring diagrams and check the brewer wiring harness.

Removal and Replacement:

1. Disconnect the wires from the rectifier.
2. Remove the #6-32 truss head screw securing the rectifier to the brew base plate.
3. Remove the rectifier and discard.
4. Install new rectifier on base plate and secure with a #6-32 truss head screw.
5. Refer to Fig. 29 when reconnecting the wires.

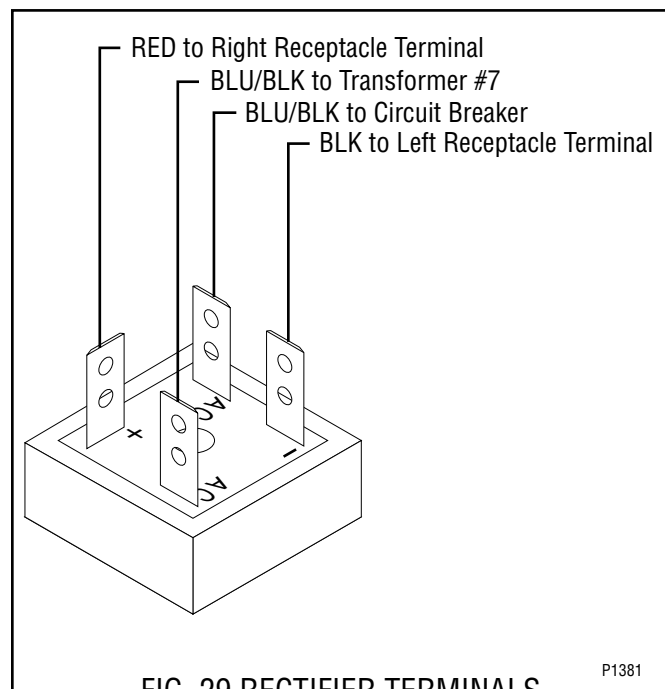

FIG. 29 RECTIFIER TERMINALS

RELAY (Brewers W/Recovery Booster)

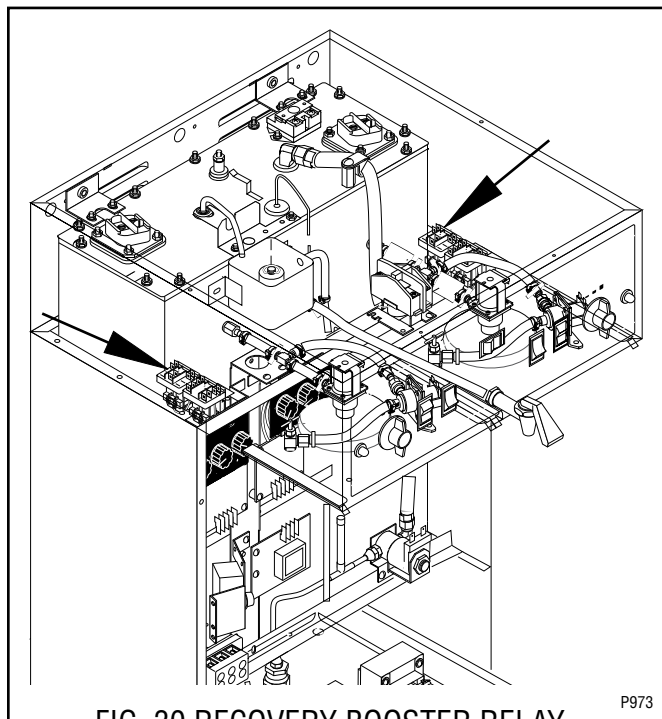

FIG. 30 RECOVERY BOOSTER RELAY

Location:

The relays are located inside the hood, the right relay is just to the right of the contactor in front of the tank and the left relay is just left of the component bracket in front of the tank.

Test Procedures:

1. Disconnect the brewer from the power source.
2. Locate the black wire on the left relay center terminal and the blue wire on the right relay center terminal.
3. Check the voltage across the black and blue wire with a voltmeter. Connect the brewer to the power source. The indication must be:
 - a.) 120 volts ac for three wire 120/208 volt models and three wire 120/240 volt models.
 - b.) 200 to 240 volts ac for two wire 200, 230 or 240 volt models.
4. Disconnect brewer from the power source.

If voltage is present as described, proceed to #5. If voltage is not present as described, refer to the wiring diagrams and check the brewer wiring harness.

5. Remove the white/green wire from the "A" terminal and white/violet wire from the "B" terminal on the right relay, the white/brown from the "A" terminal

SERVICE (cont.)

Relay (Brewers W/Recovery Booster) (cont.)

and white/red wire from "B" terminal on the left relay.

6. Check for continuity across the "A" and "B" terminals of each relay.

If continuity is present as described, reconnect the white /green wire and white/violet wire to the right relay or the white/brown and the white /red wire to the left relay and proceed to #7.

If continuity is not present as described, replace the relay(s).

7. Remove the two blue wires from terminal 5 and the red wire from terminal 7 on the right relay, the black wires from terminal 5 and the red wire from terminal 7 on the left relay.
8. Check for continuity across terminals 5 and 7 of each relay by manually closing relay contact. Continuity must not be present when contact is released.

If continuity is present as described, reconnect blue wires to terminal 5 on the right relay, the black wires to terminal 5 on the left relay and the red wire to left and right terminal 7, the relays are operating properly. If continuity is not present as described, replace the relay(s).

Removal and Replacement:

1. Remove all wires from relay terminals.
2. Remove the #6-32 truss head screw securing relay to the relay mounting bracket.
3. Remove the relay and discard.
4. Securely install the new relay to the mounting bracket using a #6-32 truss head screw.
5. Refer to Fig. 31 when reconnecting the wires.

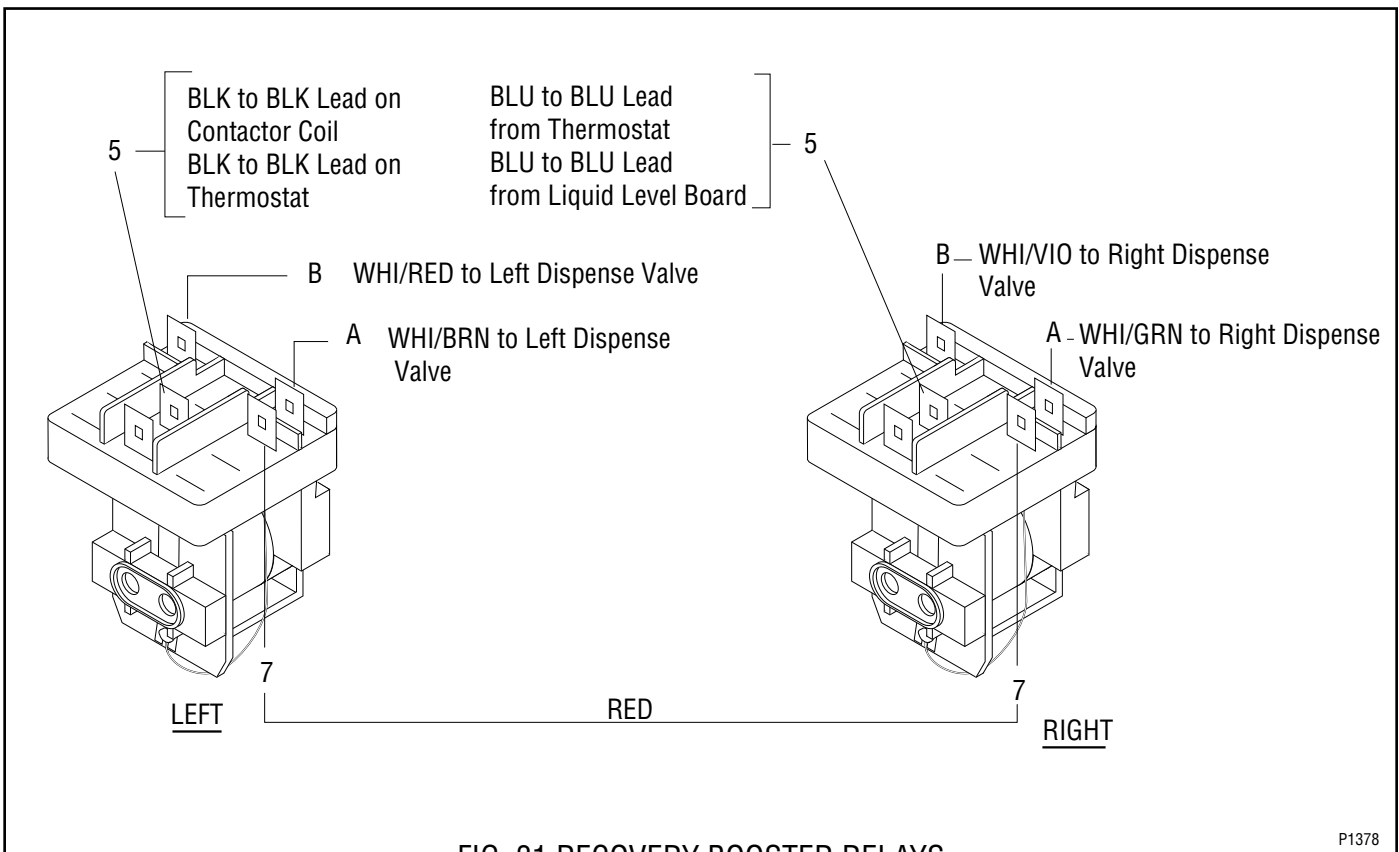

FIG. 31 RECOVERY BOOSTER RELAYS

P1378

SERVICE (cont.)

RELAY (SERVER POWER)

(Dual brewers prior to S.N. DUAL026000)

(Single brewers prior to S.N. SNG0014000)

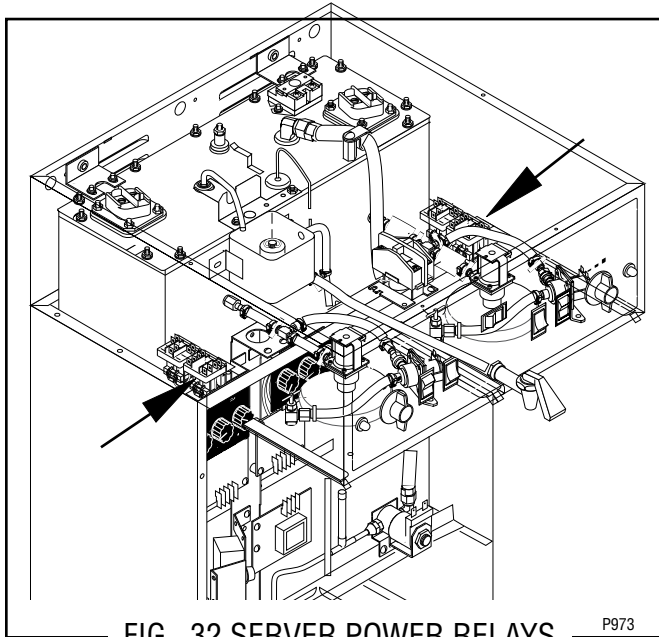

FIG. 32 SERVER POWER RELAYS P973

Location:

The relay(s) are located inside the hood, in front of the tank.

NOTE: On brewers with recovery boost, the server power relays are located just in front of the recovery boost relays.

Test Procedures:

1. Disconnect the brewer from the power source.
2. Disconnect the white or red wire from terminal "B" and the green wire from the terminal "A" of the left or right server power relay coil. Check the voltage across the white or red wire and the green wire. Connect the brewer to the source. Place the ON/OFF switch in the "ON" position, press and hold the start switch. The indication must be:
 - a.) 120 volts ac for two wire 120 volt models, three wire 102/208 volt models and three wire 120/240 volt models.
 - b.) 200 to 240 volts ac for two wire 200, 230 or 240 volt models.
3. Disconnect the brewer from the power source.

If voltage is present as described, proceed to #4

If voltage is not present as described, refer to the wiring diagram and check the brewer wiring harness.

4. Check for continuity across the "A" and "B" terminals of the relay.

If continuity is present as described, reconnect the white or red wire to terminal "B" and the green wire to terminal "A" and proceed to #5.

If continuity is not present as described, replace the relay.

5. Disconnect the yellow wire from terminal 6 and the orange wire from terminal 9 on the left relay or the white/yellow from terminal 6 and white/orange wire from terminal 9 on Single brewers and the right relay on Dual brewers.
6. Check for continuity across terminals 6 and 9 of the relay by manually closing the relay contacts. Continuity must not be present when the contacts are released.

If continuity is present as described, reconnect the yellow wire to terminal 6 and the orange wire to terminal 9 for the left relay or the white/yellow wire to terminal 6 and the white/orange wire to terminal 9 of the relay for Single brewers or right relay for Dual brewers.

7. On Single brewers or left or right relay on Dual brewers, disconnect the black wires from terminals 1 and 7 of the relay.
8. Check for continuity across terminals 1 and 7 until the contacts are manually opened and that continuity returns when the contacts are released.

If continuity was present as described, reconnect the wires to terminals 1 and 7.

If continuity was present as described in steps #6 and #8 the relay is operating properly.

If continuity is not present as described, replace the relay.

Removal and Replacement:

1. Remove all the wires from the relay terminals.
2. Remove the #6-32 screw securing the relay to the relay mounting bracket.
3. Remove and discard relay.
4. Securely install the new relay to the mounting bracket using a #6-32 screw.
5. Refer to Fig. 33 when reconnecting the wires.

SERVICE (cont.)

RELAY (SERVER POWER)(cont.)

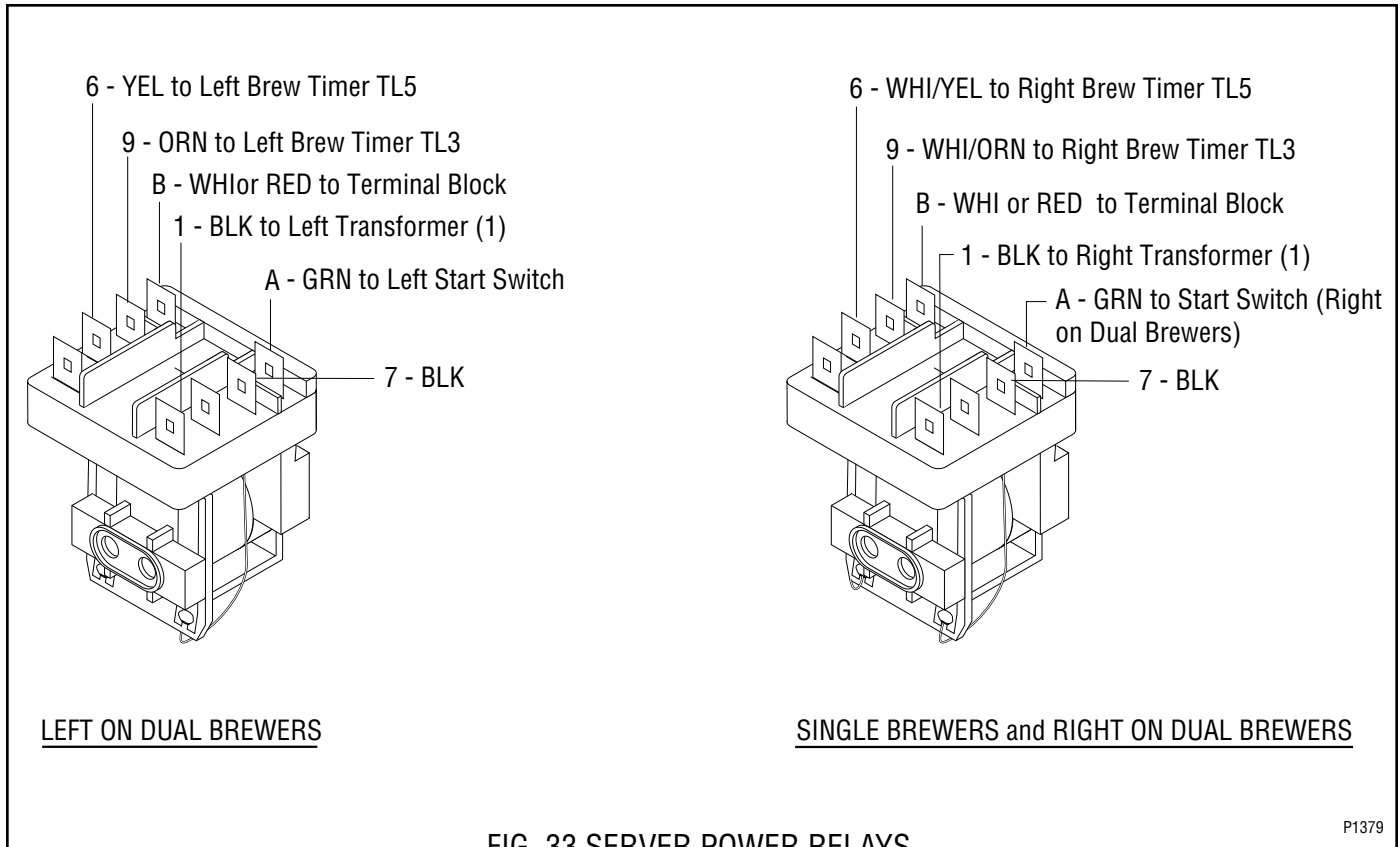

P1379

SERVICE (cont.)

RELAY (Brewers W/Recovery Booster)

NOTE - Electro/mechanically controlled brewers have two relays and the electronically controlled have one.

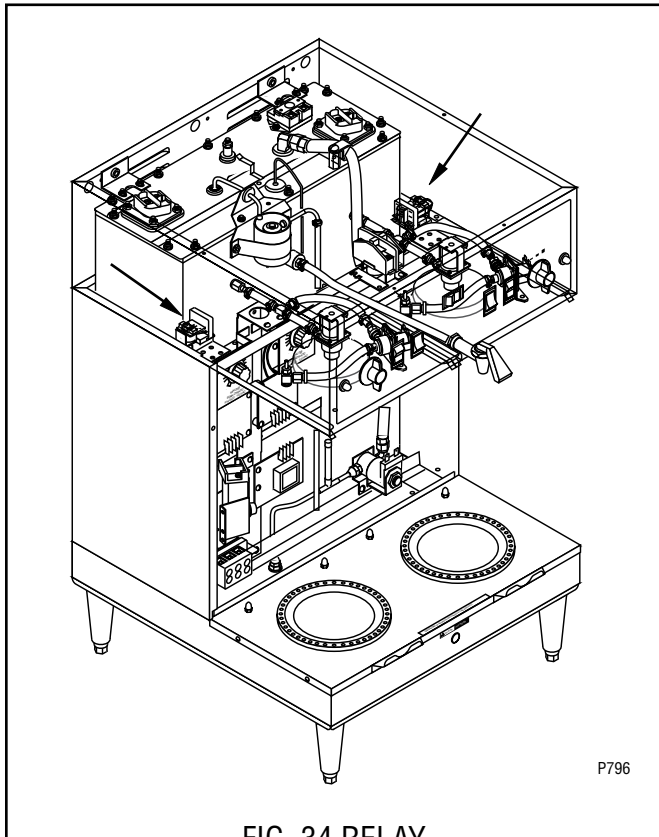

FIG. 34 RELAY

Location:

Electro/mechanically Controlled Brewers

The relays are located inside the hood, the right relay just to the right of the contactor in front of the tank and left relay is just left of the component bracket in front of the tank.

Electronically Controlled Brewers

The relay is located inside the hood just to the right of the contactor in front of the tank.

Test Procedures:

Electro/mechanically Controlled Brewers.

1. Disconnect the brewer from the power source.
2. Locate the black wire on the left center relay terminal and the blue wire on the right center relay terminal.
3. With a voltmeter, check the voltage across the black and blue wire. Connect the brewer to the power source. The indication must be:

a.) 120 volts ac for three wire 120/208 volt models and three wire 120/240 volt models.

b.) 200 to 240 volts ac for two wire 200 or 240 volt models.

4. Disconnect brewer from the power source.

If voltage is present as described, proceed to #5. If voltage is not present as described, refer to the *Wiring Diagrams* and check brewer wiring harness.

5. Remove the white/green wire from the "A" terminal and white/violet wire from the "B" terminal on the right relay, the white/brown wire from the "A" terminal and white/red wire from "B" terminal on the left relay.
6. Check for continuity across the "A" and "B" terminals of each relay.

If continuity is present as described, reconnect the white/green wire and white/violet wire to the right relay or the white/brown wire and the white/red wire to the left relay and proceed to #7.

If continuity is not present as described, replace the relay(s).

7. Remove the two blue wires from terminal 5 and the red wire from terminal 7 on the right relay, the black wires from terminal 5 and the red wire from terminal 7 on the left relay.
8. Check for continuity across terminals 5 and 7 of each relay by manually closing relay contact. Continuity must not be present when contact is released.

If continuity is present as described, reconnect blue wires to terminal 5 on the right relay, the black wires to terminal 5 on the left relay and the red wire to left and right terminal 7, the relays are operating properly.

If continuity is not present as described, replace the relay(s).

Electronically Controlled Brewers

1. Disconnect brewer from the power source.
2. Locate the gray wire on terminal 7 and the white/green wire on terminal B of the relay.
3. Check the voltage across the gray and white/green

SERVICE (cont.)

Relay (Brewers W/Recovery Booster) (cont.)

wire with left and right "ON/OFF" switch in the "ON" position. Connect the brewer to the power source and press the left and right start switch. The indication must be:

- a.) 120 volts ac for three wire 120/208 volt models and three wire 120/240 volt models.
- b.) 200 to 240 volts ac for two wire 200 or 240 volt models.

4. Disconnect brewer from the power source.

If voltage is present as described, proceed to #5. If voltage is not present as described, refer to the *Wiring Diagrams* and check brewer wiring harness.

- 5. Locate the white/red wire on the relay terminal 5 and the gray wire relay terminal 7.
- 6. Check for continuity across the relay terminals 5

and 7 by manually closing relay contact. Continuity must not be present when contact is released.

If continuity is present as described, reconnect the wires, the relay is operating properly.

If continuity is not present as described, replace the relay.

Removal and Replacement:

- 1. Remove all wires from relay terminals.
- 2. Remove the #8-32 slotted screw holding relay mounting bracket to the hood.
- 3. Remove the relay from the mounting bracket.
- 4. Securely install the new relay to the mounting bracket.
- 5. Install the relay mounting to the hood.
- 6. Refer to Fig. 27 when reconnecting the wires.

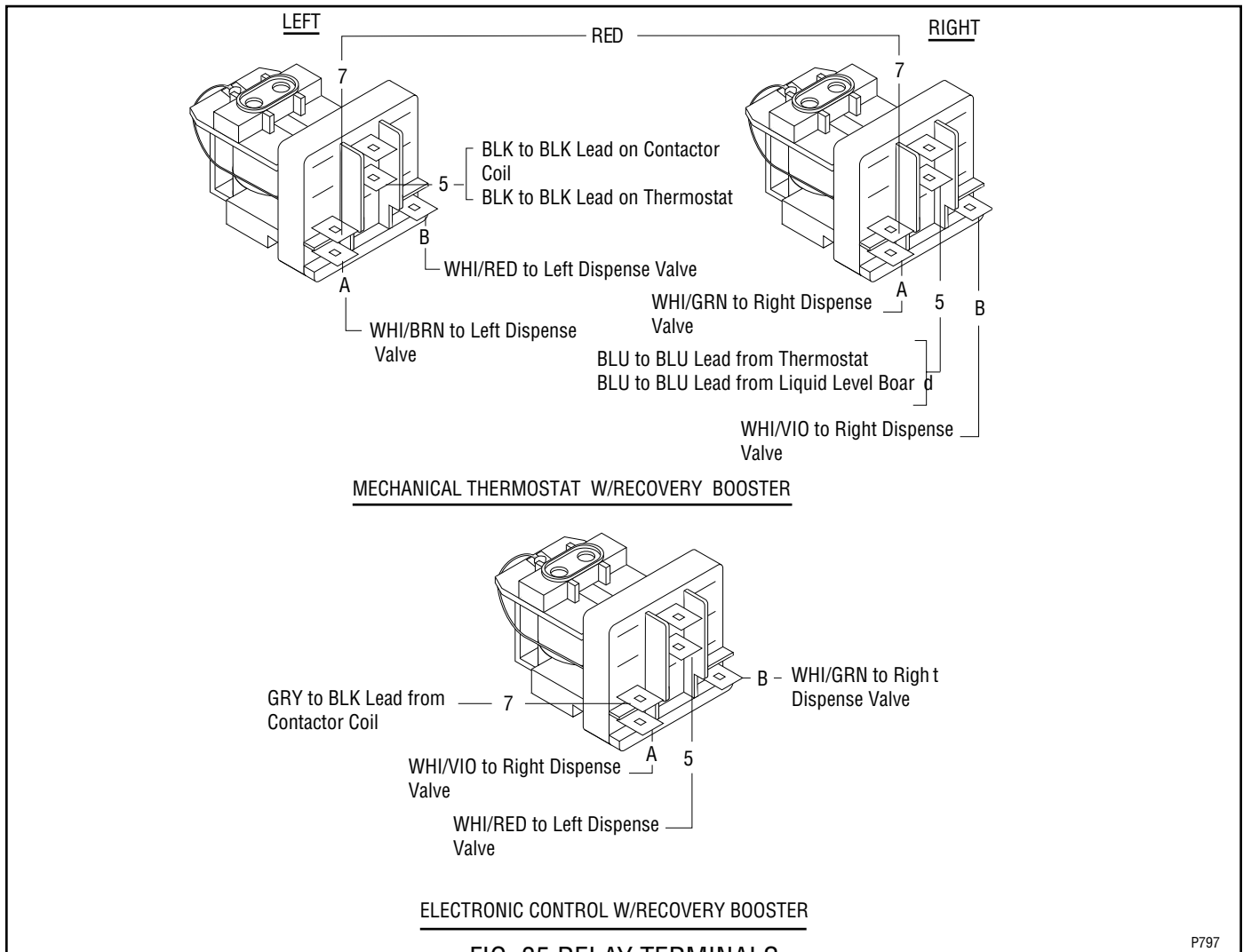

FIG. 35 RELAY TERMINALS

P797

SERVICE (cont.)

SOLENOID VALVE (Inlet)

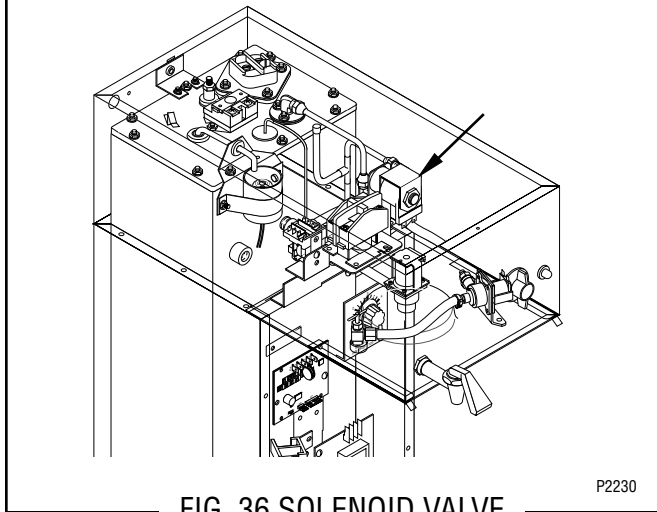
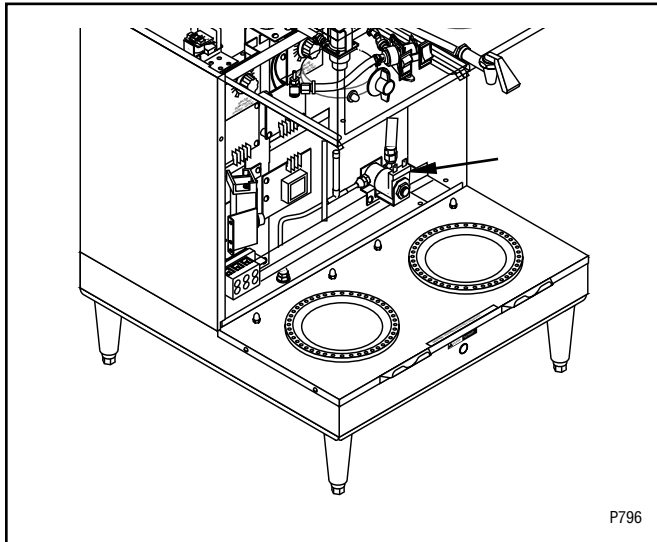

FIG. 36 SOLENOID VALVE

Location:

The solenoid valve is located inside the lower right front of Dual brewers and inside the hood on the upper component bracket on Single brewers.

Test Procedure:

1. Disconnect the brewer from the power source.
2. Remove both wires from the solenoid valve coil terminals.
3. With a voltmeter, check the voltage across the removed wires:
 - a.) Violet and white on 120, 120/208 and 120/240 volt three wire electro/mechanical models.
 - b.) Violet and red on 200, 230 and 240 volt electro/mechanical models.
 - c.) White/blue and white on 120/208 volt and 120/240 volt electronic models.

d.) White/blue and red on 200 volt and 240 volt electronic models.

Connect the brewer to the power source. The indication must be:

a.) 120 volts ac for two wire 120 volt models, three wire 120/208 volt models and three wire 120/240 volt models.

b.) 200 to 240 volts ac for 200V or 240V two wire models.

4. Disconnect the brewer from the power source.

If voltage is present as described, proceed to #5. If voltage is not present as described, refer to the *Wiring Diagrams* and check brewer wiring harness.

5. Check for continuity across the solenoid valve coil terminals.

If continuity is present as described, reconnect the wires and proceed to #6.

If continuity is not present as described, replace the solenoid valve.

6. Check the solenoid valve for coil action. Connect the brewer to the power source. Listen carefully in the vicinity of the solenoid valve for a "clicking" sound after approximately 1 second, as the coil magnet attracts.

7. Disconnect the brewer from the power source.

If the sound is heard as described and water will not pass through the solenoid valve, there may be a blockage in the water line before or after the solenoid valve, or the solenoid valve may require inspection for wear, and removal of waterborne particles.

If the sound is not heard as described, replace the solenoid valve.

Removal and Replacement:

1. Remove all wires from the solenoid valve coil.
2. Turn off the water supply to the brewer.
3. Disconnect the water lines to and from the solenoid valve.
4. SINGLE BREWERS: Remove the two #10-32 slotted head screws and lockwashers holding the solenoid valve to the upper component bracket.
DUAL BREWERS: Remove the two #8-32 slotted head screws holding the solenoid valve and mounting bracket to the brewer trunk. Remove the two

41976 031709

SERVICE (cont.)

- #10-32 slotted head screws holding the solenoid valve to the mounting bracket.
7. Securely install the new solenoid valve to its mounting bracket.
 8. DUAL BREWERS: Attach the solenoid valve and mounting bracket to the brewer trunk.
 9. Securely fasten the water lines to and from the solenoid valve.
 10. Refer to Fig. 37 when reconnecting the wires.

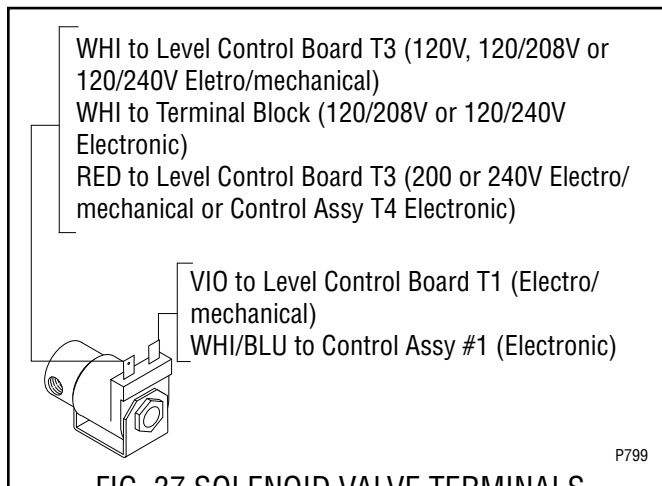

SERVICE (cont.)

START SWITCHES

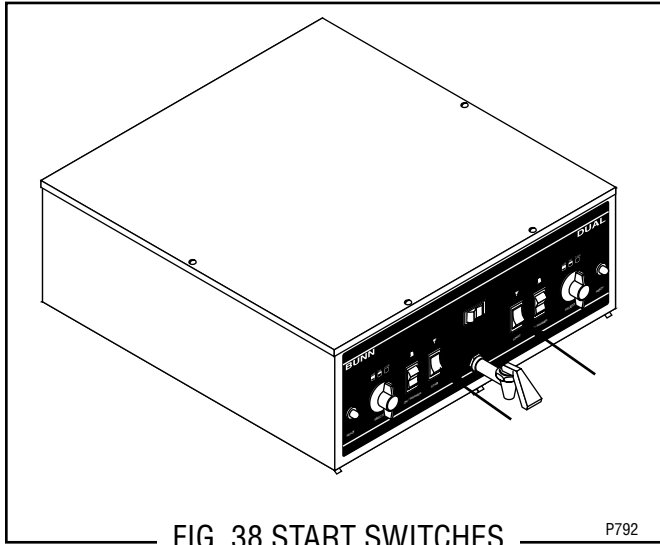

FIG. 38 START SWITCHES

P792

Location:

The momentary start switches are located on the front of the hood next to the on/off switches.

Test Procedure:

1. Disconnect the brewer from the power source and remove the wires from both terminals of the switch.
2. Check for continuity across the two terminals on the switch when it is held in the lower position. Continuity must not be present across these terminals in the upper position.

If continuity is present as described, reconnect the wires, the switch is operating properly.

If continuity is not present as described, replace the switch.

Removal and Replacement:

1. Remove wires from the switch terminals.
2. Compress the clips inside the hood and gently push the switch through the opening.
3. Push the new switch into the opening and spread the clips to hold the switch in the hood.
4. Refer to Fig. 39 when reconnecting the wires.

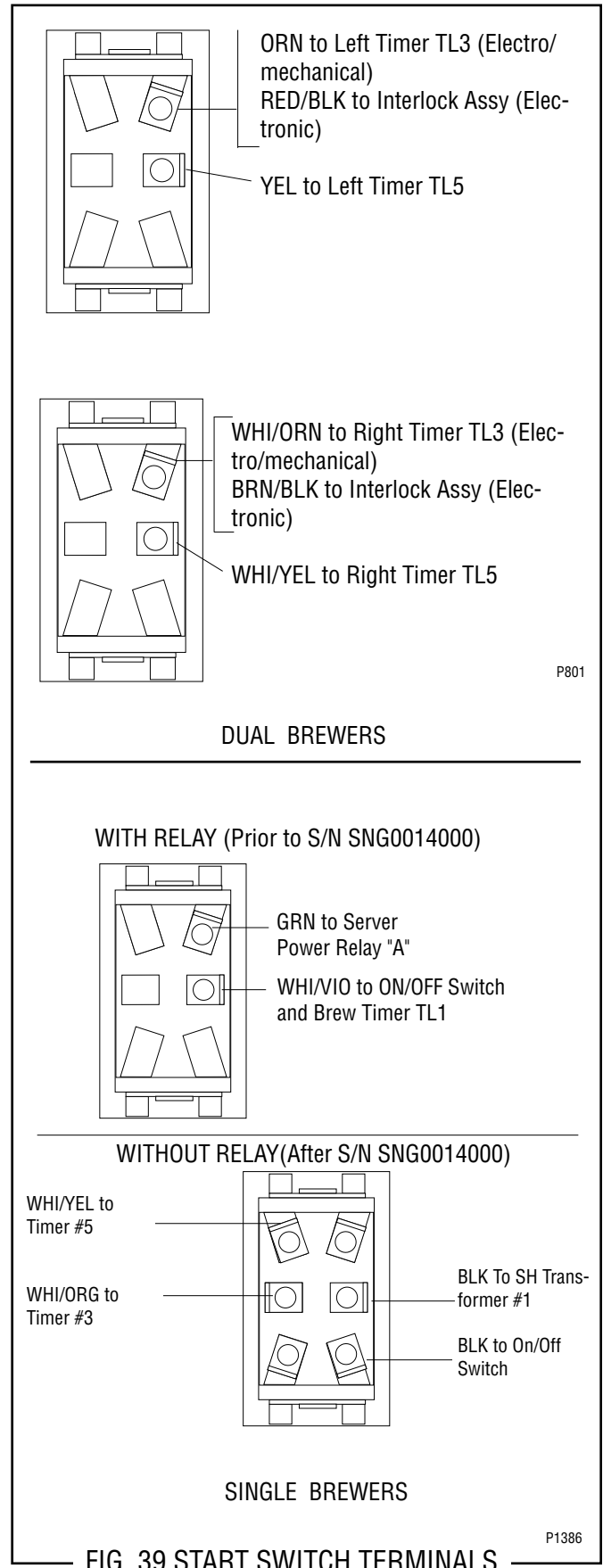

DUAL BREWERS

P801

WITH RELAY (Prior to S/N SNG0014000)

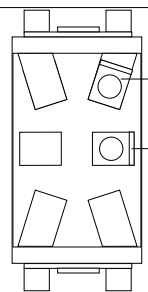

WITHOUT RELAY (After S/N SNG0014000)

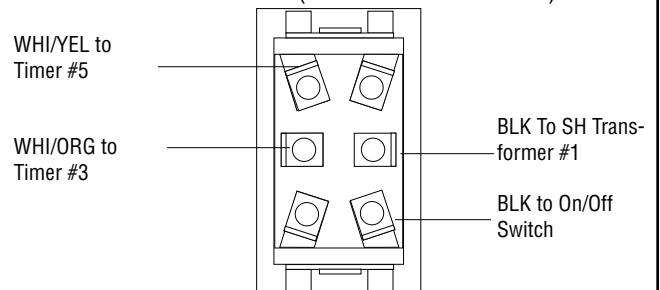

SINGLE BREWERS

FIG. 39 START SWITCH TERMINALS

P1386

SERVICE (cont.)

TANK HEATERS

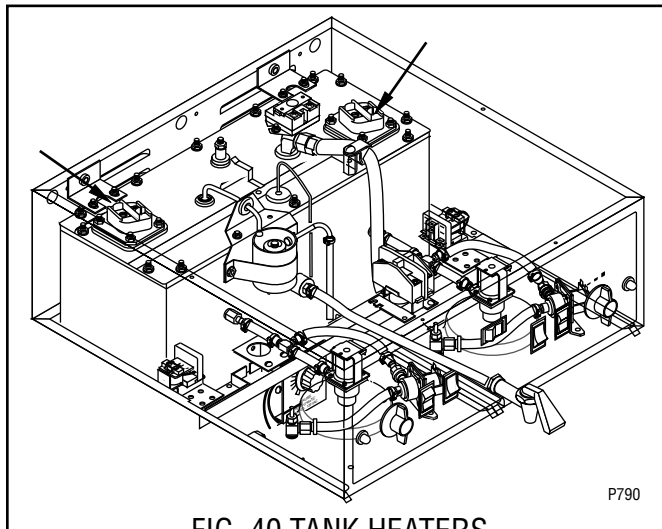

FIG. 40 TANK HEATERS

Location:

The tank heaters are located on the left and right side of the tank lid.

Test Procedure:

Electro/Mechanical Models.

1. Disconnect the brewer from the power supply.
2. Check the voltage across the black and the red wires on 120V, 120/208V or 120/240V models on the tank heaters. With the control thermostat turned to the "ON" position (fully clockwise), connect the brewer to the power supply and with a voltmeter, check the voltage across the wires. The indication should be:
 - a.) 120 volts ac for two wire 120V models, 208 volts ac for three wire 120/208 volt models and 240 volts ac for three wire 120/240 volt models.
 - b.) 200 to 240 volts ac for two wire 200 or 240 volt models.
3. Disconnect the brewer from the power supply.

If voltage is present as described, proceed to #4.

If voltage is not present as described, refer to the *Wiring Diagrams* and check the wiring harness.

4. Disconnect wires from the tank heater(s) and check for continuity across the terminals of the tank heater(s).

If continuity is present as described, reconnect the wires, the tank heaters are operating properly.

If continuity is not present as described, replace the tank heater(s).

NOTE - If the tank heater remains unable to heat, remove and inspect the heater for cracks in the sheath.

Electronic Models:

1. Disconnect the brewer from the power source.
2. Disconnect wires from heater(s).
3. Check for continuity across the tank heater terminals.

If continuity is present as described, the tank heater is operating properly.

If continuity is not present as described, replace the tank heater.

NOTE - If the tank heater remains unable to heat, remove and inspect the heaters for cracks in the sheath.

Removal and Replacement:

1. Remove wires from tank heater.
2. Remove the four #8-32 nuts securing tank heater to tank lid.
3. Remove tank heater and gasket.
4. Install new tank heater and gasket with four #8-32 nuts on tank lid.
5. Refer to Fig. 41 when reconnecting the wires.

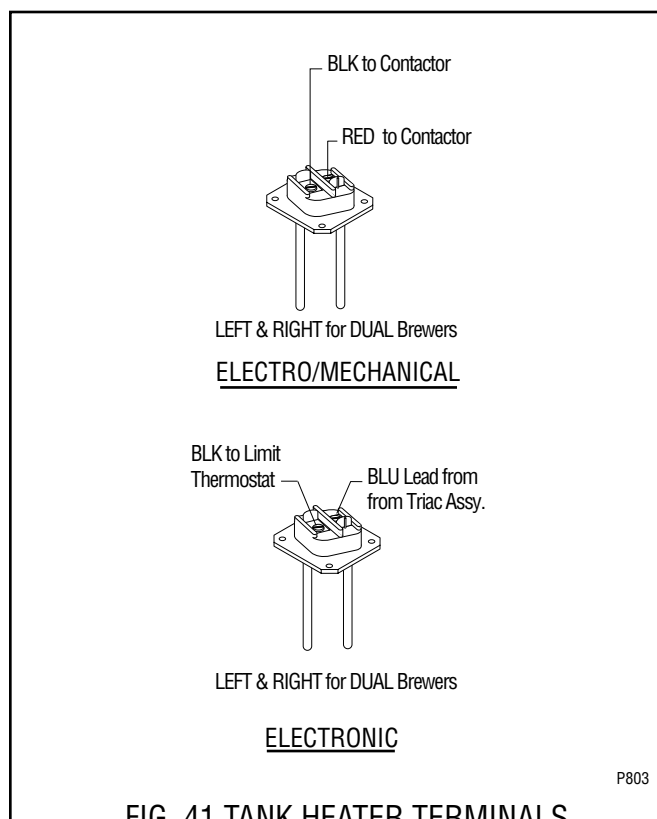
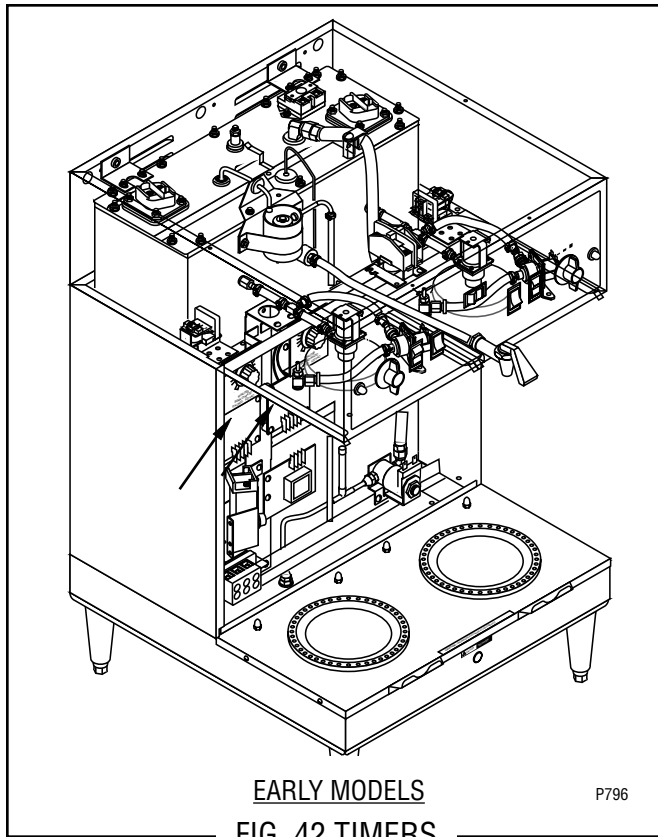

FIG. 41 TANK HEATER TERMINALS

SERVICE (cont.)

TIMERS (Early Models)



Location:

The timers are located inside the left front of the brewer on the upper part of the component bracket.

Test Procedures:

1. Disconnect the brewer from the power source.
2. Disconnect the wires from the timer terminals TL3, TL4 and TL5 and rotate the dial(s) fully counter-clockwise.
3. With a voltmeter, check the voltage across terminals TL1 and TL2 when the "ON/OFF" switch is in the "ON" position. Connect the brewer to the power source. The indication must be:
 - a.) 120 volts ac for two wire 120 volt models, three wire 120/208 volt models and three wire 120/240 volt models.
 - b.) 200 to 240 volts ac for two wire 200 or 240 volt models.
4. Disconnect the brewer from the power source. If voltage is present as described, proceed to #5. If voltage is not present as described, refer to the *Wiring Diagrams* and check brewer wiring harness.

NOTE: ECA MODELS ONLY - Brewer must be at operating temperature to perform step 5 or brew-lock must be bypassed. To bypass brew-lock on DUAL models, disconnect white/orange wire and brown/black wire for right timer or orange wire and red/black wire for left timer from brew-lock of ECA and connect the harness leads together. To bypass brew-lock on SINGLE models, disconnect white/yellow and orange wires from brew-lock of ECA and connect the harness leads together.

5. With the start switch pressed, check for continuity across the wires disconnected from TL3 and TL5 of the timer. DUAL models will be white/orange and white/yellow wires for right timer or the orange and yellow wires for left timer. SINGLE models will be white/orange and white yellow wires for electro/mechanical brewers and white/yellow and yellow wires on electronic brewers.

If continuity is present as described, reconnect the wires to terminals TL3, TL4 and TL5 of the timer board and brew-lock wires if necessary, and proceed to #6.

6. Check the voltage across terminals TL1 and TL4 with a voltmeter when the "ON/OFF" switch is in the "ON" position. Connect the brewer to the power source and press the start switch. The indication must be:
 - a.) 120 volts ac for two wire 120 volt models, three wire 120/208 volt models and three wire 120/240 volt models for approximately 1 minute for 1-1/2 gallon batch.
 - b.) 200 to 240 volts ac for two wire 200 or 240 volt models for approximately 1 minute for 1-1/2 gallon batch.
7. Select a 1 gallon batch and repeat #6. The indication should remain for approximately 40 seconds.
8. Select a 1/2 gallon batch and repeat #6. The indication should remain approximately 20 seconds.

Removal and Replacement:

1. Remove all wires from the timer.
2. Remove the four #6-32 slotted head screws holding circuit board and dial plate on to the component mounting bracket.
3. Remove circuit board, nylon spacers and dial plate.

SERVICE (cont.)

Timers (Early Models)(cont.)

4. Install new timer circuit board as described in *Digital Timer* section on the following pages.
5. Refer to Fig. 43 or 44 when reconnecting wires.
6. Install the timer setting decal provided with the replacement timer kit, on the inside of the front access panel.
7. Adjust timer as required. Refer to *Digital Timer* section on the following pages.

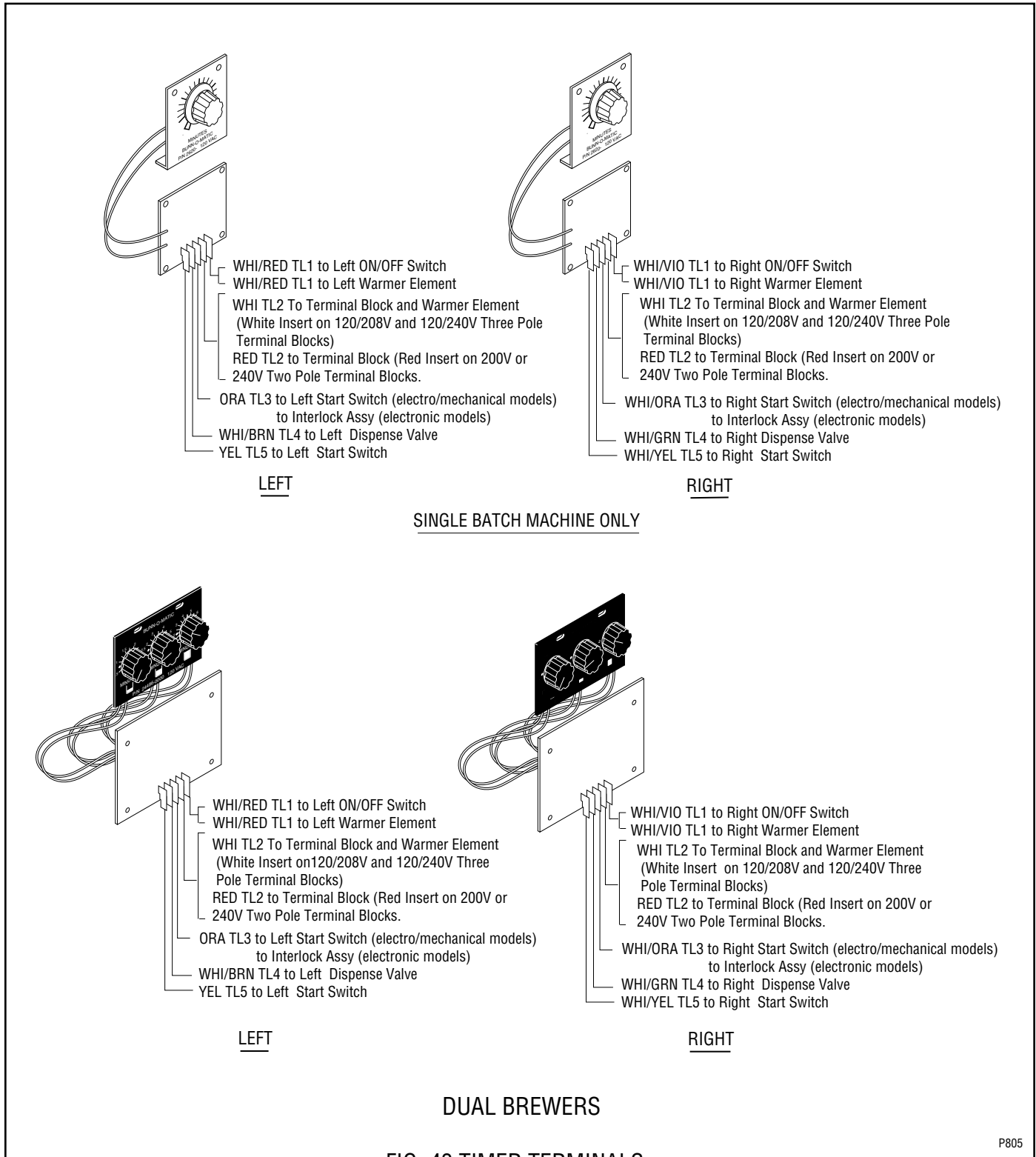
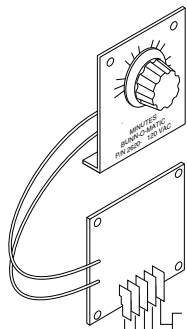

FIG. 43 TIMER TERMINALS

P805

SERVICE (cont.)

Timers (Early Models)(cont.)



- WHI/VIO TL1 to ON/OFF Switch
- WHI/VIO TL1 to Warmer Element
- WHI TL2 To Terminal Block and Warmer Element (120V Two Pole, 120/208V or 120/240V Three Pole Terminal Block)
- RED TL2 to Terminal Block and Warmer Element (200V or 240V Two Pole Terminal Block)
- WHI/ORA TL3 to Start Switch (Top)
- WHI/GRN TL4 to Dispense Valve (Upper Front)
- WHI/YEL TL5 to Start Switch (Bottom)

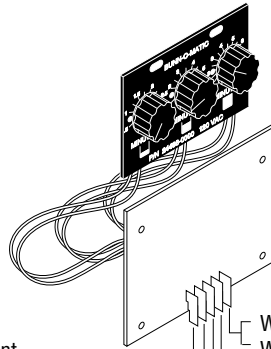

- WHI/VIO TL1 to ON/OFF Switch
- WHI/VIO TL1 to Warmer Element
- WHI TL2 To Terminal Block and Warmer Element (120V Two Pole, 120/208V or 120/240V Three Pole Terminal Block)
- RED TL2 to Terminal Block and Warmer Element (200V or 240V Two Pole Terminal Block)
- WHI/ORA TL3 to Start Switch (Top)
- WHI/GRN TL4 to Dispense Valve (Upper Front)
- WHI/YEL TL5 to Start Switch (Bottom)

ELECTRO/MECHANICAL

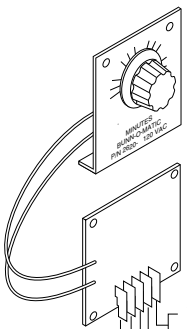

- WHI/VIO TL1 to ON/OFF Switch
- WHI/VIO TL1 to Warmer Element
- WHI TL2 To Terminal Block and Warmer Element (120V Two Pole, 120/208V or 120/240V Three Pole Terminal Block)
- RED TL2 to Terminal Block and Warmer Element (200V or 240V Two Pole Terminal Block)
- WHI/YEL TL3 to Interlock Assy
- WHI/GRN TL4 to Dispense Valve
- YEL TL5 to Start Switch

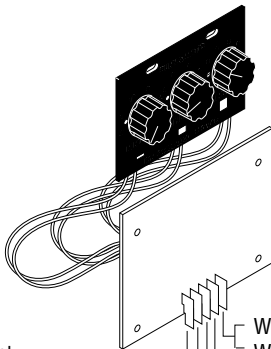

- WHI/VIO TL1 to ON/OFF Switch
- WHI/VIO TL1 to Warmer Element
- WHI TL2 To Terminal Block and Warmer Element (120V Two Pole, 120/208V or 120/240V Three Pole Terminal Block)
- RED TL2 to Terminal Block and Warmer Element (200V or 240V Two Pole Terminal Block)
- WHI/YEL TL3 to Interlock Assy
- WHI/GRN TL4 to Dispense Valve
- YEL TL5 to Start Switch

ELECTRONIC

SINGLE BREWERS

FIG. 44 TIMER TERMINALS

P838

SERVICE (cont.)

TIMERS (Late Models)

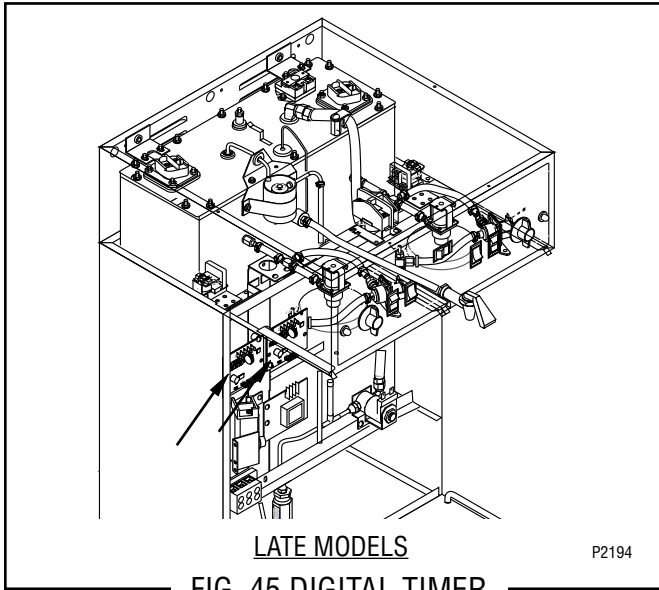

FIG. 45 DIGITAL TIMER

Location:

The timers are located inside the left front of the brewer on the upper part of the component bracket.

Test Procedure.

NOTE: Do not remove or install wires while timer board is installed. Pressure applied to one side may cause damage to the board.

1. Disconnect the brewer from the power source and remove the front access panel.
2. Remove the two #8-32 screws securing circuit board to the mounting bracket.
3. Remove circuit board and spacers (as required).
4. With a voltmeter, check the voltage across terminals TL1 and TL2 when the "ON/OFF" switch is in the "ON" position. Connect the brewer to the power source. The indication must be:
 - a) 120 volts ac for two wire 120 volt models, three wire 120/208 volt models and 120/240 volt models.
 - b) 200 to 240 volts ac on two wire 200 volt or 240 volt models.
5. Disconnect the brewer from the power source.

If voltage is present as described, proceed to #6. If voltage is not present as described, refer to the *Wiring Diagrams* and check the brewer wiring harness.

6. With a voltmeter, check the voltage across terminals TL1 and TL4 when the "ON/OFF" switch is in the "ON" position. Connect the brewer to the power source. The indication must be 0 volts.

If voltage is as described, proceed to #7.

If voltage is not as described, disconnect the brewer from the power source and replace the timer.

7. With a voltmeter, check the voltage across terminals TL1 and TL4 when the "ON/OFF" switch is in the "ON" position. Connect the brewer to the power source and press the "START" switch. The indication must be as follows:
 - a) 120 volts ac for two wire 120 volt models, three wire 120/208 volt models and 120/240 volt models.
 - b) 200 to 240 volts ac on two wire 200 volt or 240 volt models.

If voltage is present as described, the brew timer is operating properly. Reset the timer as required, to obtain the desired brew volume.

If voltage is not present as described, disconnect the brewer from the power source and replace the timer.

Removal and Replacement:

NOTE: Do not remove or install wires while timer board is installed. Pressure applied to one side may cause damage to the board.

1. Remove the two #8-32 screws securing circuit board to the mounting bracket.
2. Remove circuit board and spacers (as required).
3. Remove all wires from the timer.
4. Attach all wires to the replacement timer board prior to installation to the component mounting bracket. Refer to FIG. 46 when reconnecting the wires.
5. Install new circuit board with spacers (as required) to the component mounting bracket.
6. Adjust the timer as described below.

Timer Setting:

NOTE: Prior to setting or modifying volumes, check that the brewer is connected to water supply, the tank is properly filled, and a funnel and server are in place.

NOTE: All volume settings must be done with the sprayhead installed.

SERVICE (cont.)

TIMERS (Late Models)(cont.)

1. **Modifying brew volumes.** To modify a brew volume, first check that the SET/LOCK switch is in the "SET" position on the circuit board.

To increase a brew volume, place the ON/OFF switch in the "ON" position, press and hold the START switch until three clicks are heard. Release the switch and press it again one or more times. (Failure to release the switch within two seconds after the third click causes the volume setting to be aborted and previous volume setting will remain in memory.) Each time the switch is pressed, two seconds are added to the brew time period. Allow the brew cycle to finish in order to verify that the desired volume has been achieved.

To decrease a brew volume, place the ON/OFF switch in the "ON" position, press and release the START switch once for every two-second interval to be removed from the total brew time period; then immediately press and hold down the START switch until three clicks are heard. Release the switch. (Failure to release the switch within two seconds after the third click causes the volume setting to be aborted and previous volume setting will remain in memory). Allow the brew cycle to finish in order to verify that the desired volume has been achieved.

2. **Setting brew volumes.** To set a brew volume, first check that the SET/LOCK switch is in the "SET" position on the circuit board. Place the ON/OFF switch in the "ON" position, press and hold the START switch until three distinct clicks are heard and then release the switch. (Failure to release the switch within two seconds after the third click causes the volume setting to be aborted and previous volume setting will remain in memory.)

View the level of the liquid being dispensed. When the desired level is reached, turn the ON/OFF switch to "OFF".

NOTE: The brewer remembers this volume and will continue to brew batches of this size until the volume setting procedure is repeated.

NOTE: When brewing coffee, volume will decrease due to absorption by the coffee grounds.

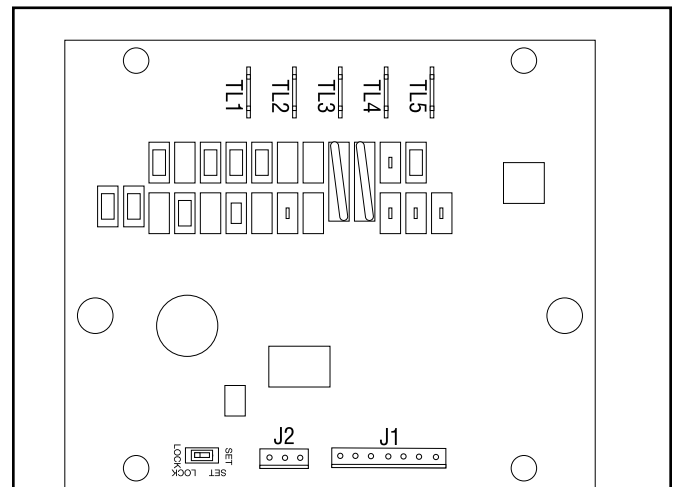

LEFT TIMER (Dual Brewers)

YEL	TL5
WHI/BRN	TL4
ORA	TL3
WHI	TL2 (120V Two Pole, 120/208V or 120/240V Three Pole Terminal Block)
RED	TL2 (200V or 240V Two Pole Terminal Block)
WHI/RED	TL1

TIMER (Single Brewers)

RIGHT TIMER (Dual Brewers)

WHI/YEL	TL5
WHI/GRN	TL4
WHI/ORA	TL3
WHI	TL2 (120V Two Pole, 120/208V or 120/240V Three Pole Terminal Block)
RED	TL2 (200V or 240V Two Pole Terminal Block)
WHI/VIO	TL1

P2037

FIG. 46 DIGITAL TIMER TERMINALS

3. **Setting programming disable feature.** If it becomes necessary to prevent anyone from changing brew time once programmed, you can set the SET/LOCK switch to the "LOCK" position. This will prevent any further programming until switch is once again put into the "SET" position.

SERVICE (cont.)

TRANSFORMERS (SH models only)

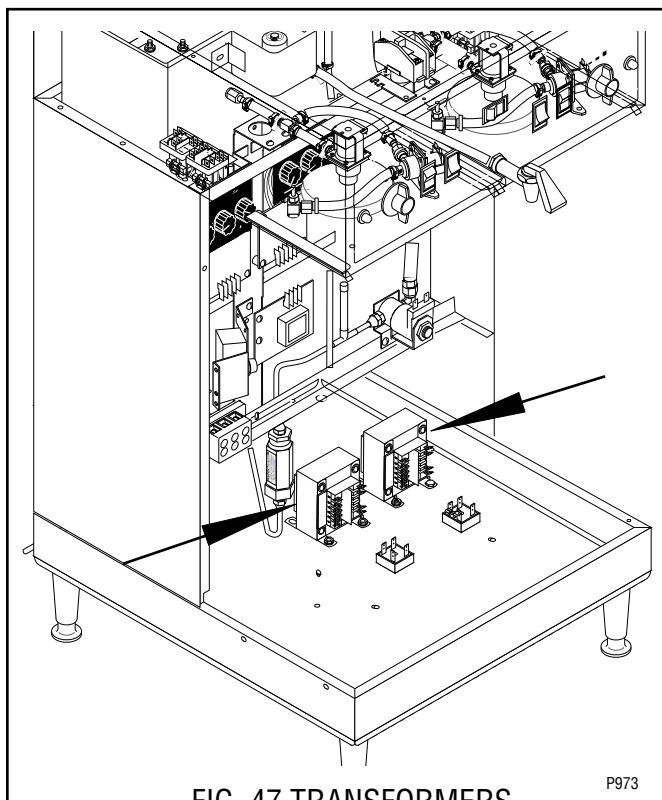

FIG. 47 TRANSFORMERS

Location:

The transformers are located in the brewer base on the right center of the base plate.

Test Procedures:

1. Disconnect the brewer from the power source.
2. Disconnect the black wire from terminal #1 (from the server relay) and the white or red wire from terminal # 6.
3. With a voltmeter check the voltage across the black and white wire. Connect the brewer to the power supply. The indication must be:
 - a.) 120 volts ac for three wire 120/208 volt models and three wire 120/240 volt models.
 - b.) 200 to 240 volts ac for two wire 200, 230 or 240 volt models.
4. Disconnect the brewer from the power supply.

If voltage is present as described reconnect the wires and proceed to #5.

If voltage is not present as described, refer to the wiring diagrams and check the brewer wiring harness.

5. Disconnect the blue/black wires from terminals #7 and #12 on the transformer.
6. With a voltmeter check the voltage across the blue/black wires. Connect the brewer to the power source. The indication must be 24 volts ac.

If voltage is present as described the transformer is operating properly.

If voltage is not present as described, replace the transformer.

Removal and Replacement:

1. Disconnect all the wires from the transformer that is to be replaced.
2. Transformers on early model brewers were attached to the base plate with four #6-32 screws or two #6-32 screws and the two #6-32 keps nuts, all must be removed to remove transformer. Late model brewers use four #6-32 keps nuts, remove the two front nuts and loosen the two rear nuts.
3. Remove transformer and discard.
4. Install new transformer on the brewer base plate securing with the #6-32 screws and/or nuts removed in step 2.
5. Refer to Fig. 48 to reconnect the wires.

SERVICE (cont.)

TRANSFORMERS (cont.)

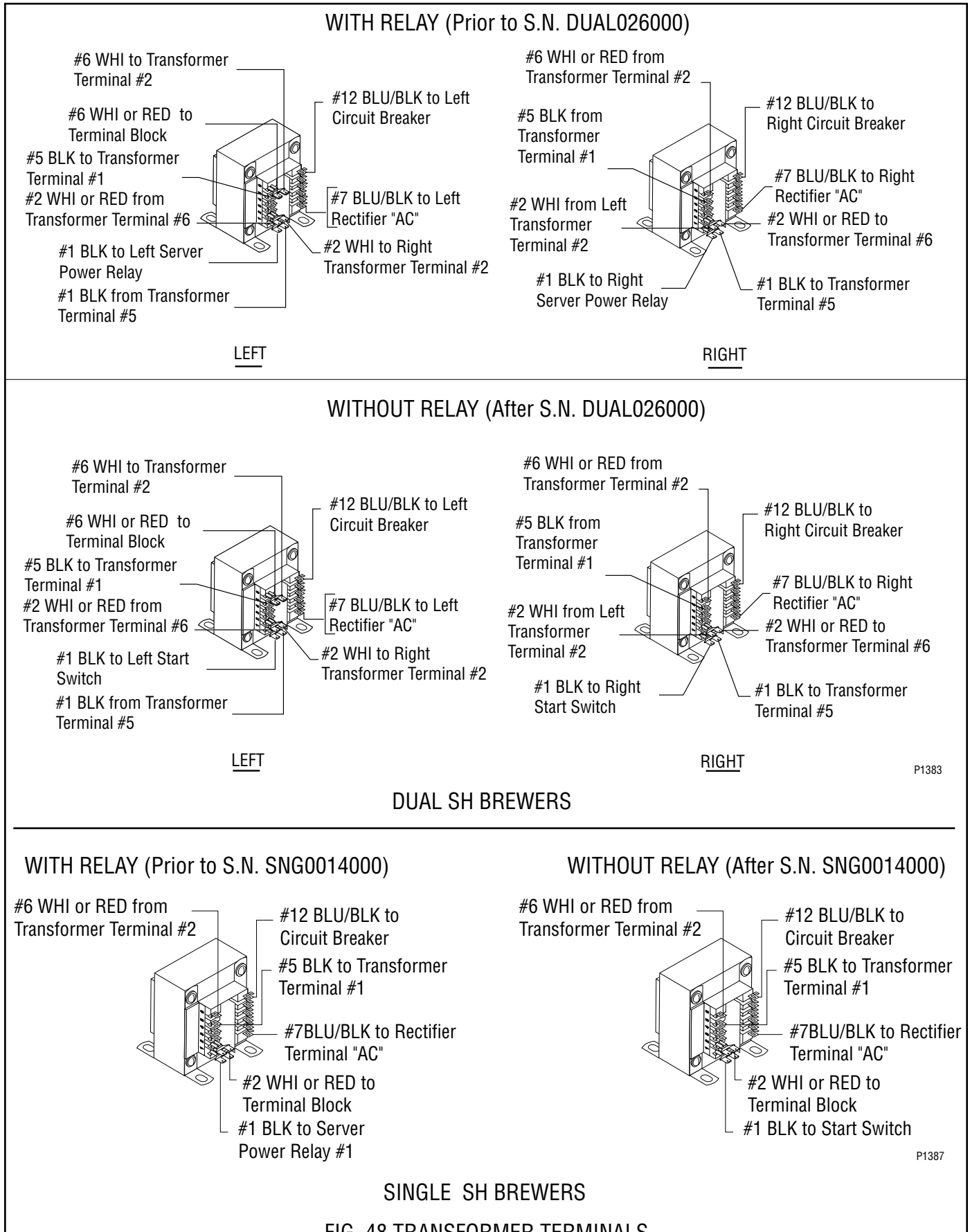

P1383

P1387

SERVICE (cont.)

WARMER ELEMENTS

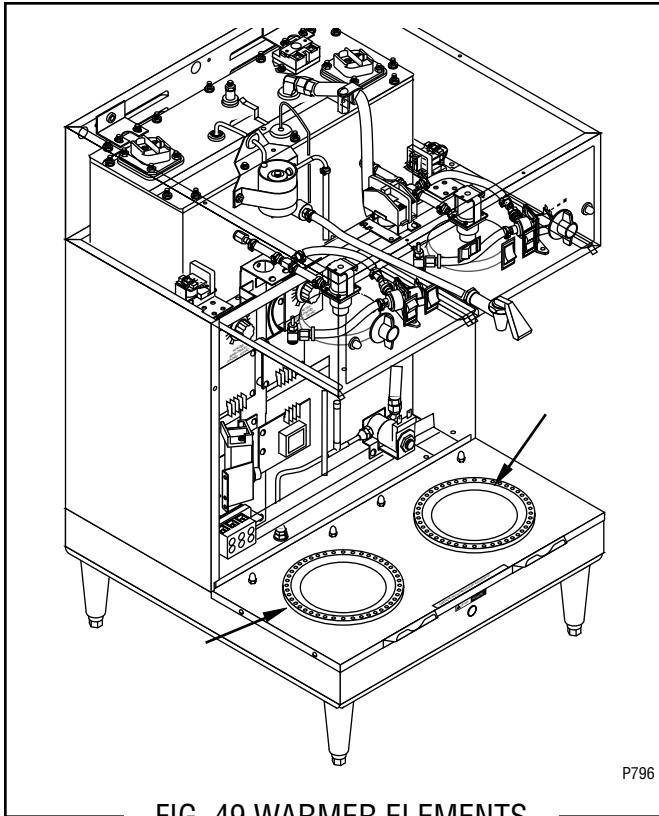

FIG. 49 WARMER ELEMENTS

Location:

The warmer element(s) are located in the base of the brewer under the warmer plate.

Test Procedures:

1. Disconnect the brewer from the power source.
2. Using the white wire in the terminal block and the white/red wire to left warmer (Dual Brewers) or the white/violet wire to warmer (Single Brewers) or right warmer (Dual Brewers) check the voltage. With a voltmeter, check voltage across the white and white/red wire or the white wire and white/violet wire with the "ON/OFF" switch in the "ON" position. The indication must be 120 volts ac for two wire 120 volt models, three wire 120/208 volt models and three wire 120/240 volt models.
3. With a voltmeter, check the voltage across the red wire and white/red wire or red wire and white/violet wire with the "ON/OFF" switch in the "ON" position. The indication must be 200 to 240 volts ac for two wire 200 or 240 volt models.
4. Disconnect the brewer from the power source.

If voltage is present as described, proceed to #5.
If voltage is not present as described, refer to the *Wiring*

Diagrams and check brewer wiring harness.

5. Check the continuity across the two terminals on the warmer element(s).

If continuity is present as described, reconnect the wires to the warmer element(s).

If continuity is not present as described, replace the warmer element(s).

Removal and Replacement:

1. Remove the three #4-40 slotted head screws securing the warmer assembly to the brewer base.
2. Lift the warmer assembly from the brewer base.
3. Disconnect the two wires from the warmer element terminals.
4. Remove the two #8-32 nuts securing the warmer element to the warmer plate.
5. Securely install new warmer element.
6. Reconnect the two wires to warmer element terminals.
7. Securely install warmer assembly in brewer base.
8. Reconnect the two wires to the warmer element.

SERVICE (cont.)

MAIN ON/OFF SWITCH

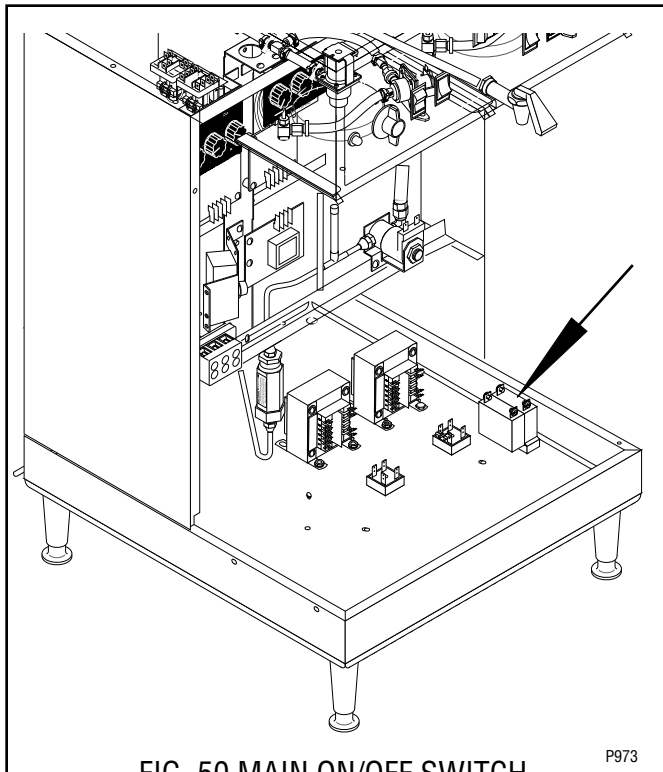

FIG. 50 MAIN ON/OFF SWITCH

P973

Location:

The MAIN ON/OFF switch is located in the base housing behind the right front leg.

Test Procedure:

1. Disconnect the brewer from the power source.
2. Remove the red wires from the terminals.
3. Check the voltage across the red wires with a voltmeter. Connect the brewer to the power source. The indication must be 120 volts ac.
4. Disconnect the brewer from the power source.

If voltage is present as described, reconnect the red wires, and repeat steps 2 and 3 for the black wires. If voltage is not present as described, refer to the *Wiring Diagrams* and check the brewer wiring harness.

5. With the red and black wires removed, check for continuity across the right terminals and across the left terminals with switch in the "ON" position. Continuity must not be present when switch is in the "OFF" position.

If continuity is present as described, reconnect the red and black wires to the terminals.

If continuity is not present as described, replace the switch.

Removal and Installation:

1. Disconnect the wires from the switch terminals.
2. Remove the two screws securing the switch to the base plate from the bottom side of the brewer.
3. Position the new switch into the opening in the base plate and secure with the two mounting screws.
4. Refer to Fig. 51 when reconnecting the wires.

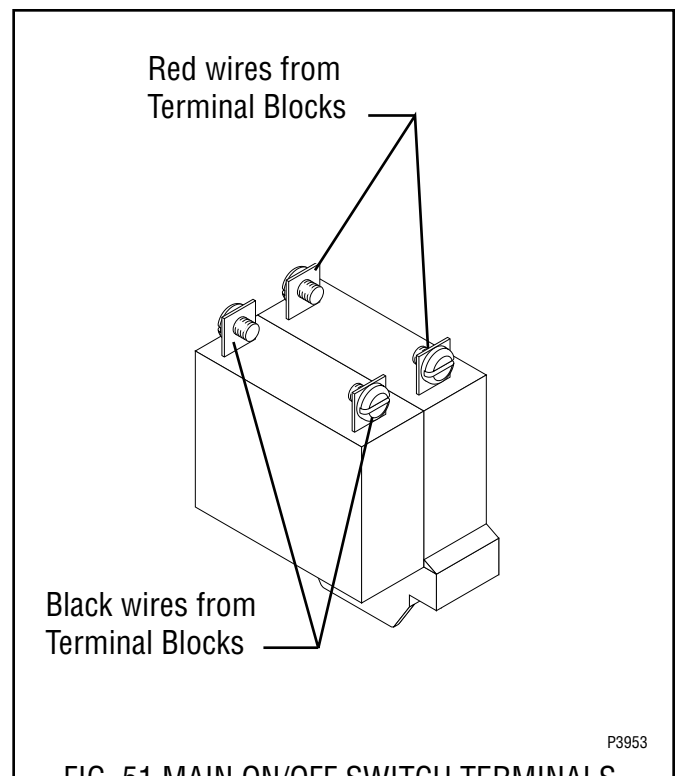
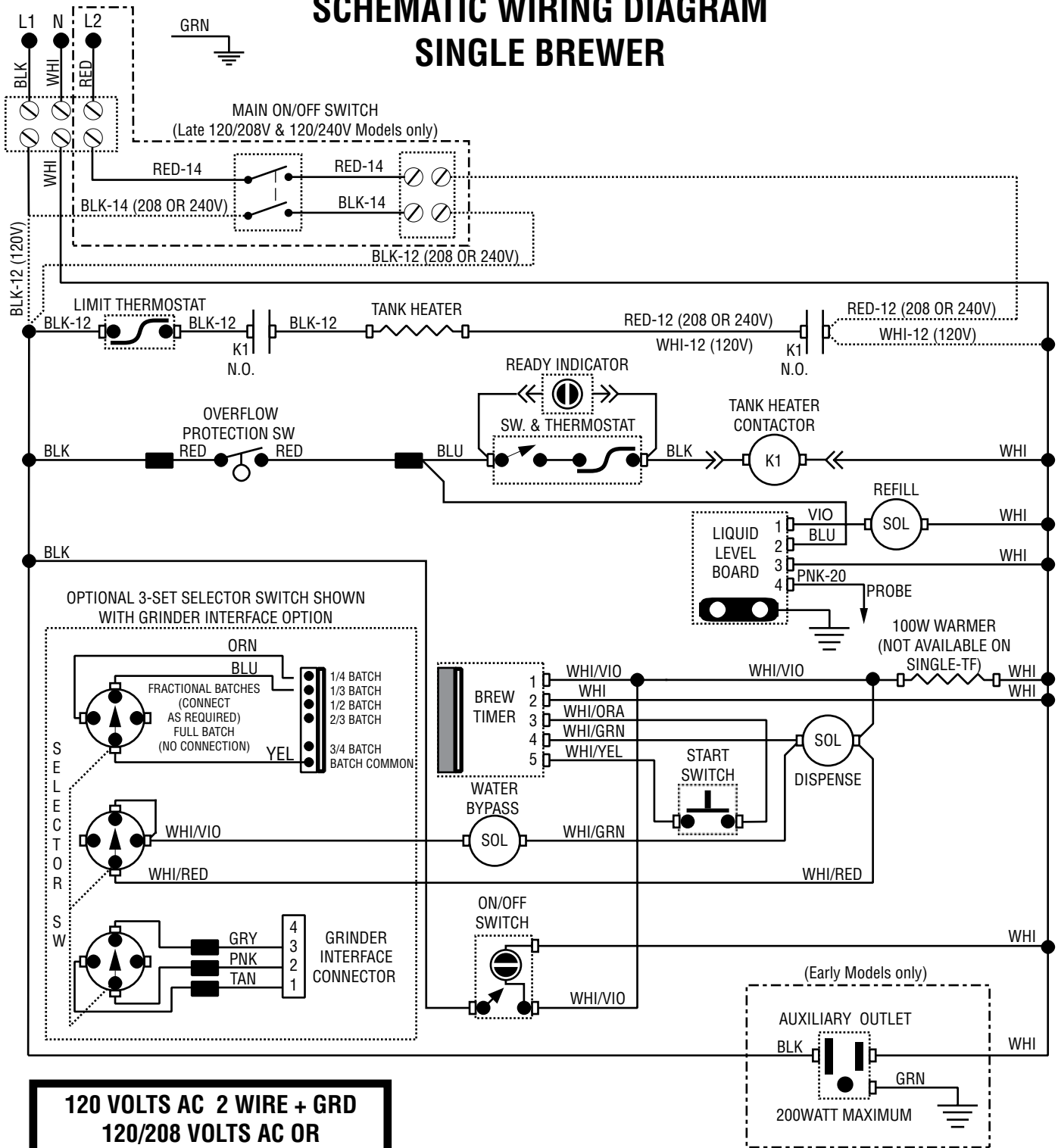

FIG. 51 MAIN ON/OFF SWITCH TERMINALS

P3953

SCHEMATIC WIRING DIAGRAM SINGLE BREWER



**120 VOLTS AC 2 WIRE + GRD
120/208 VOLTS AC OR
120/240 VOLTS AC 3 WIRE + GRD
SINGLE PHASE**

SCHEMATIC WIRING DIAGRAM SINGLE-A & -B BREWER

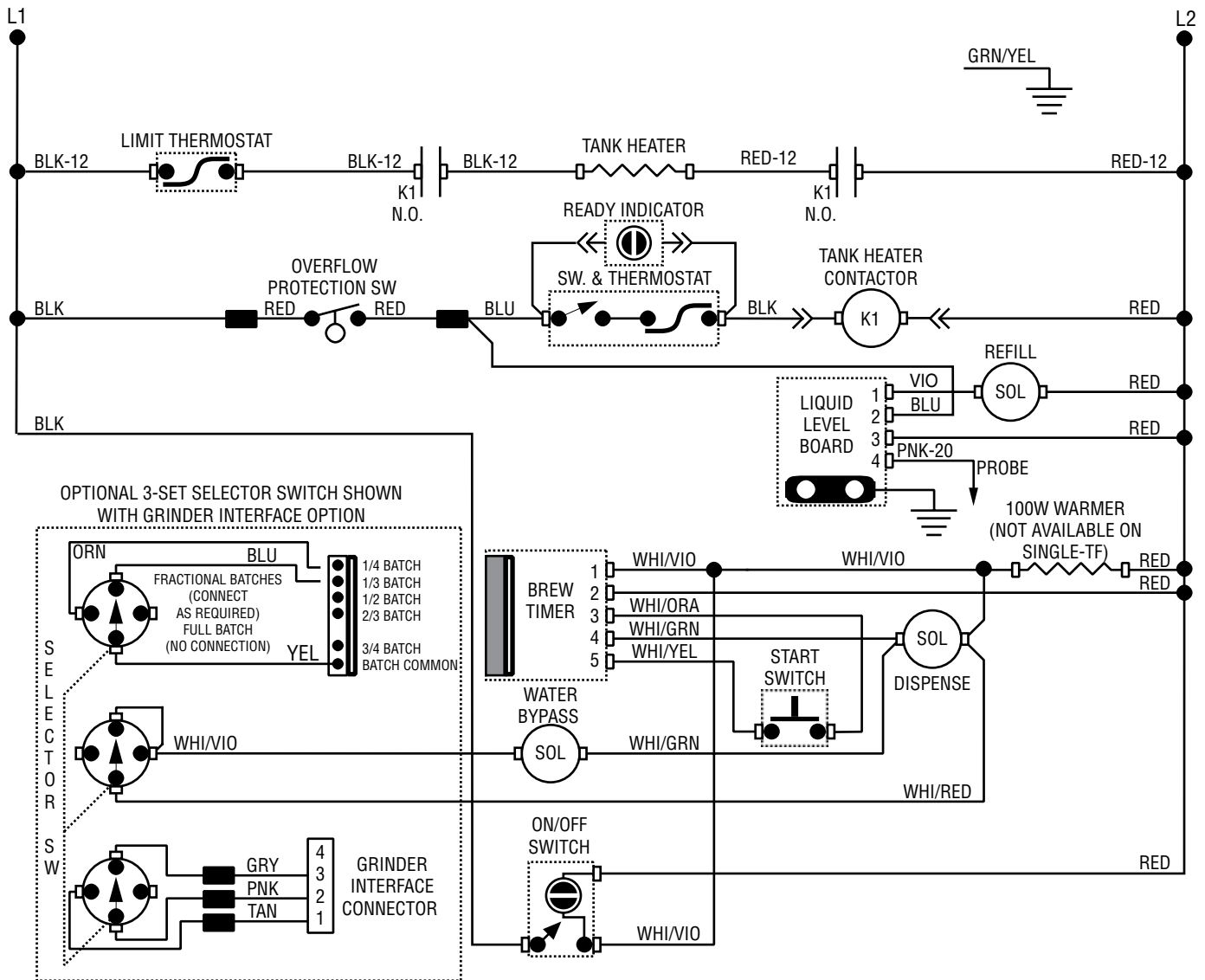

**200 OR 240 VOLTS AC
2 WIRE + GRD**

SINGLE BREWER W/DIGITAL BREWER CONTROL SCHEMATIC WIRING DIAGRAM

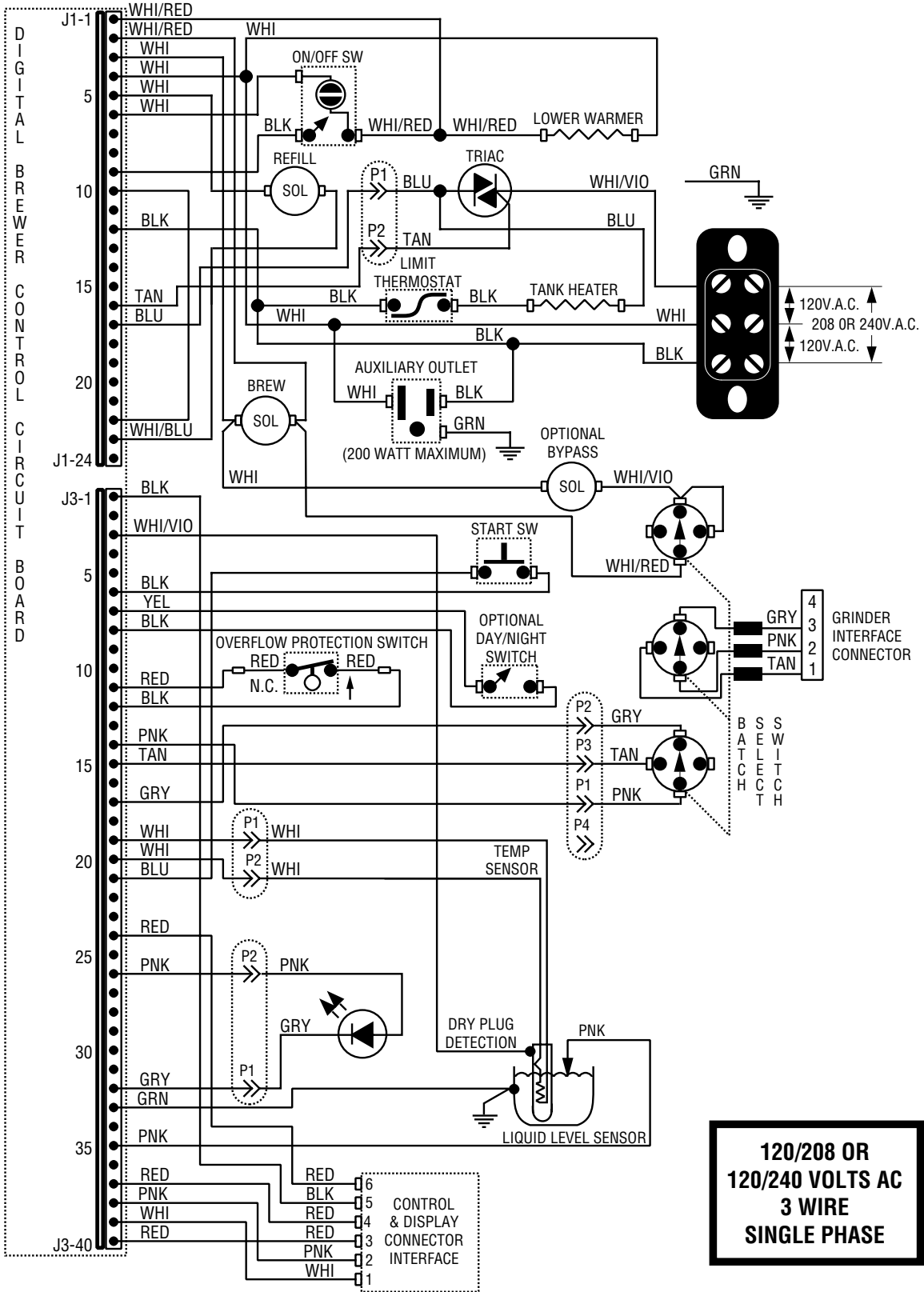

SCHEMATIC WIRING DIAGRAM

SINGLE BREWER SH

(Prior to S/N SNG0014000)

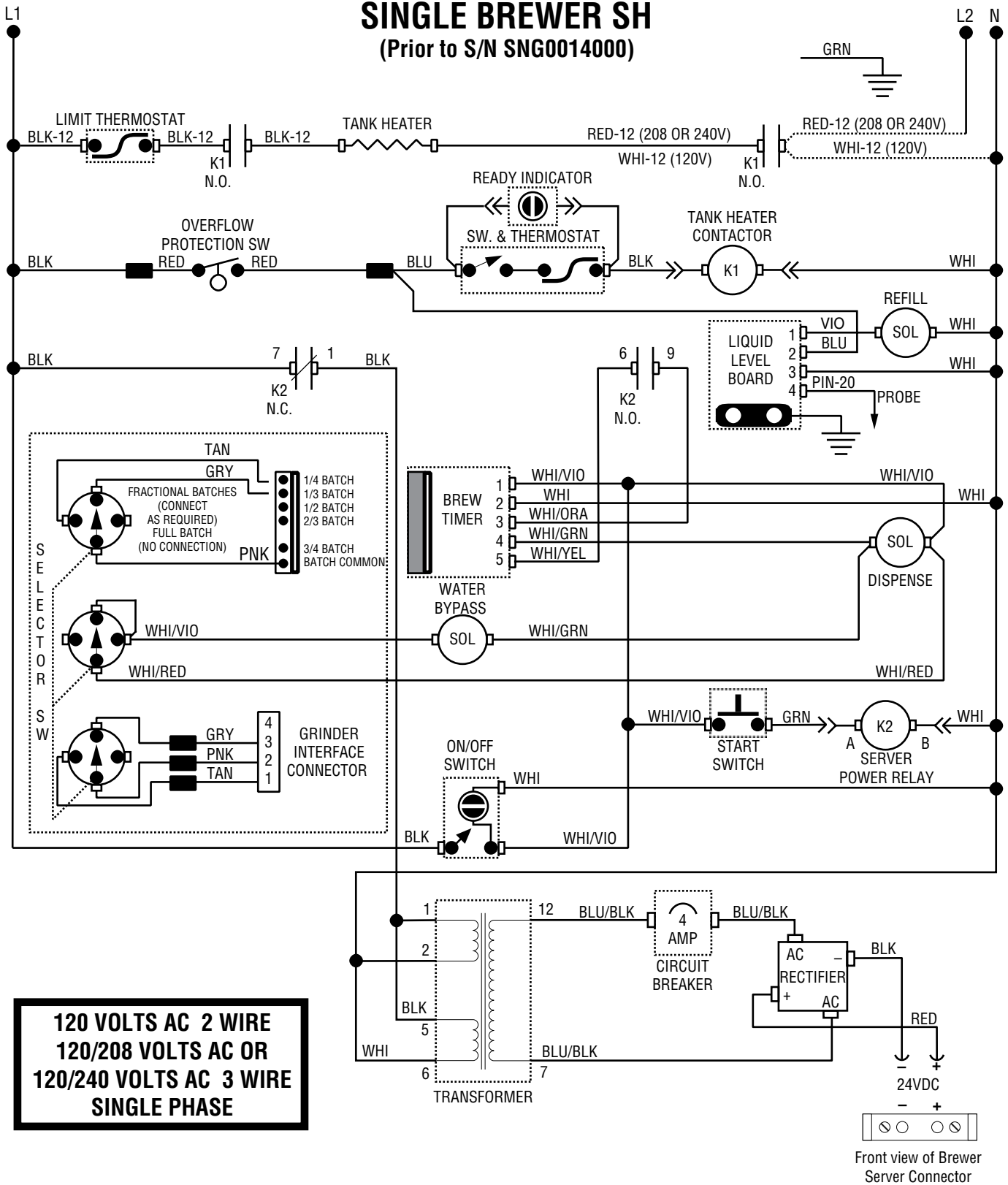

**120 VOLTS AC 2 WIRE
120/208 VOLTS AC OR
120/240 VOLTS AC 3 WIRE
SINGLE PHASE**

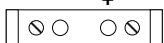

Front view of Brewer Server Connector

SCHEMATIC WIRING DIAGRAM SINGLE SH, 230V CE

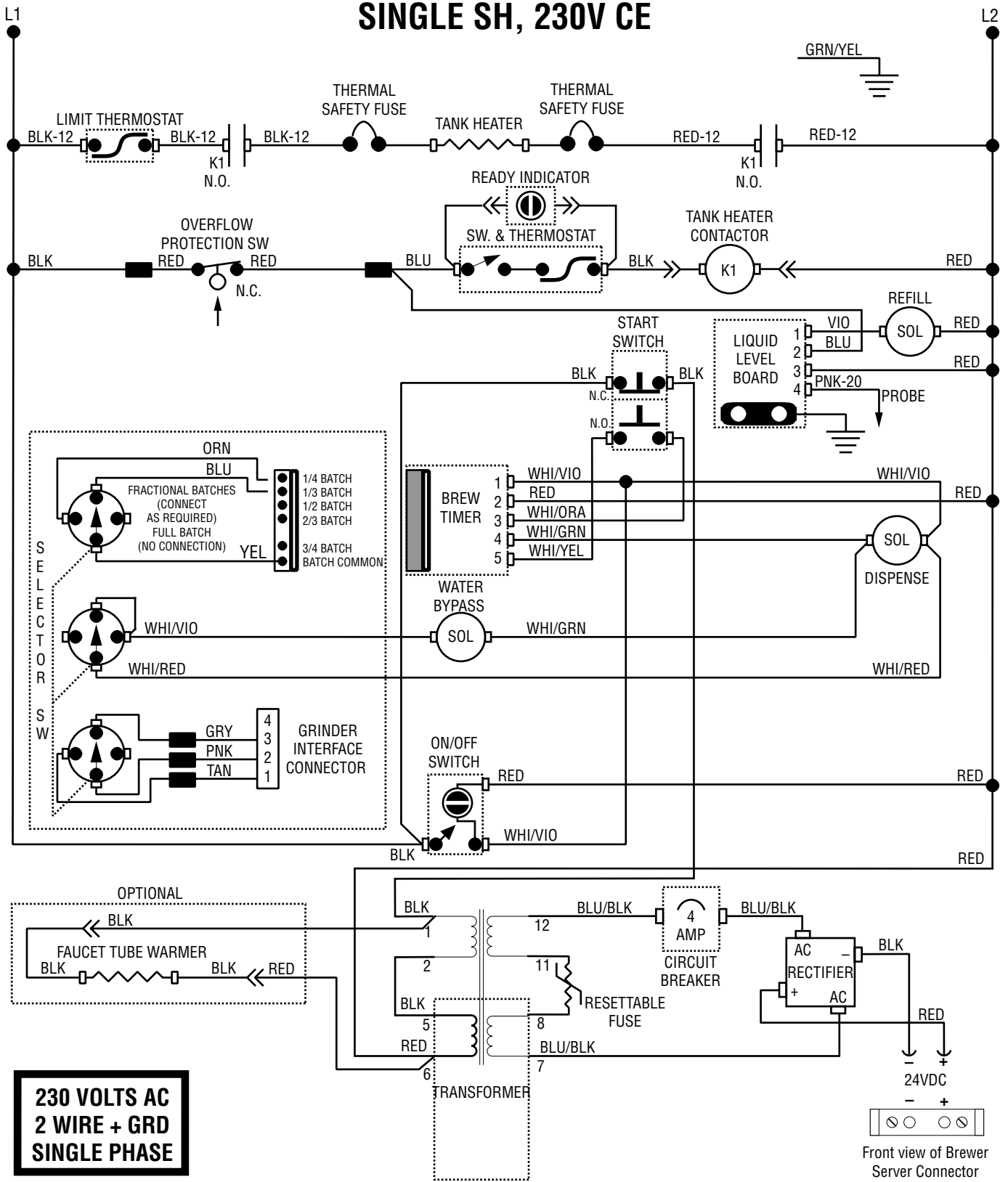

**230 VOLTS AC
2 WIRE + GRD
SINGLE PHASE**

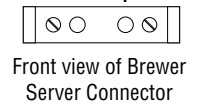

SCHEMATIC WIRING DIAGRAM SINGLE SH, 230V CE

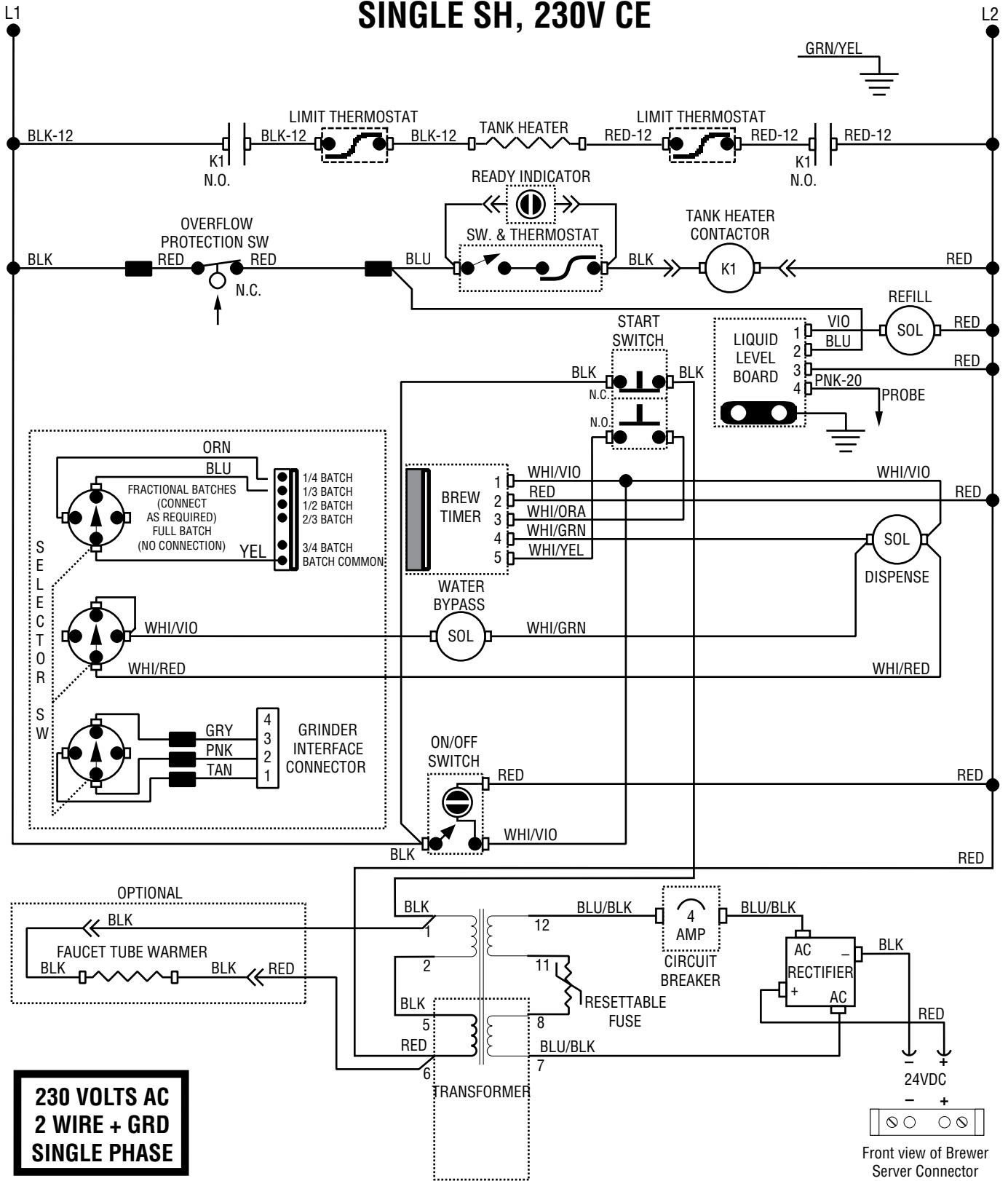

SCHEMATIC WIRING DIAGRAM

SINGLE SH, 230V CE

(Brewers W/Product #27800.0010)

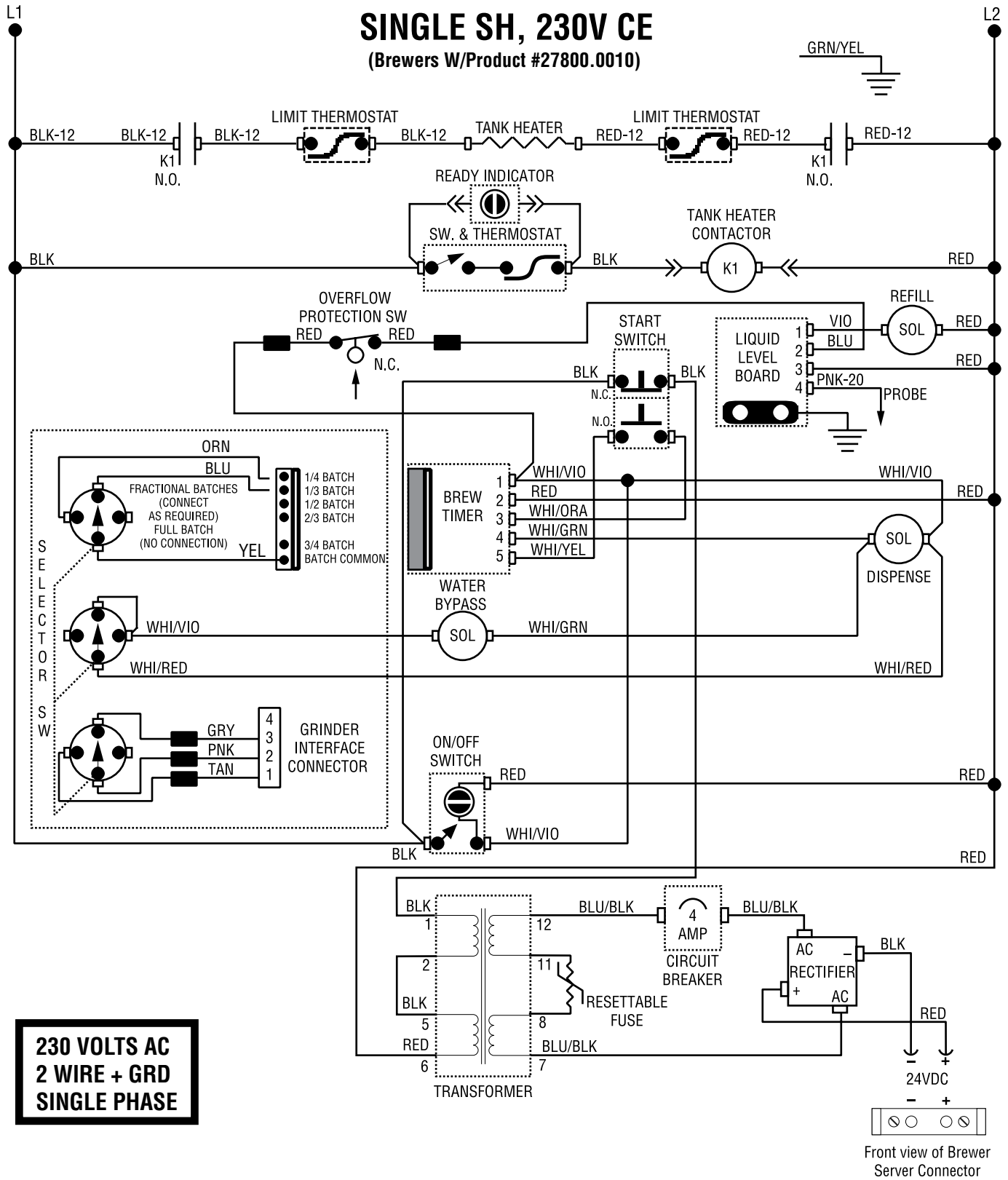

SCHEMATIC WIRING DIAGRAM SINGLE BREWER SH (After S/N SNG0014000)

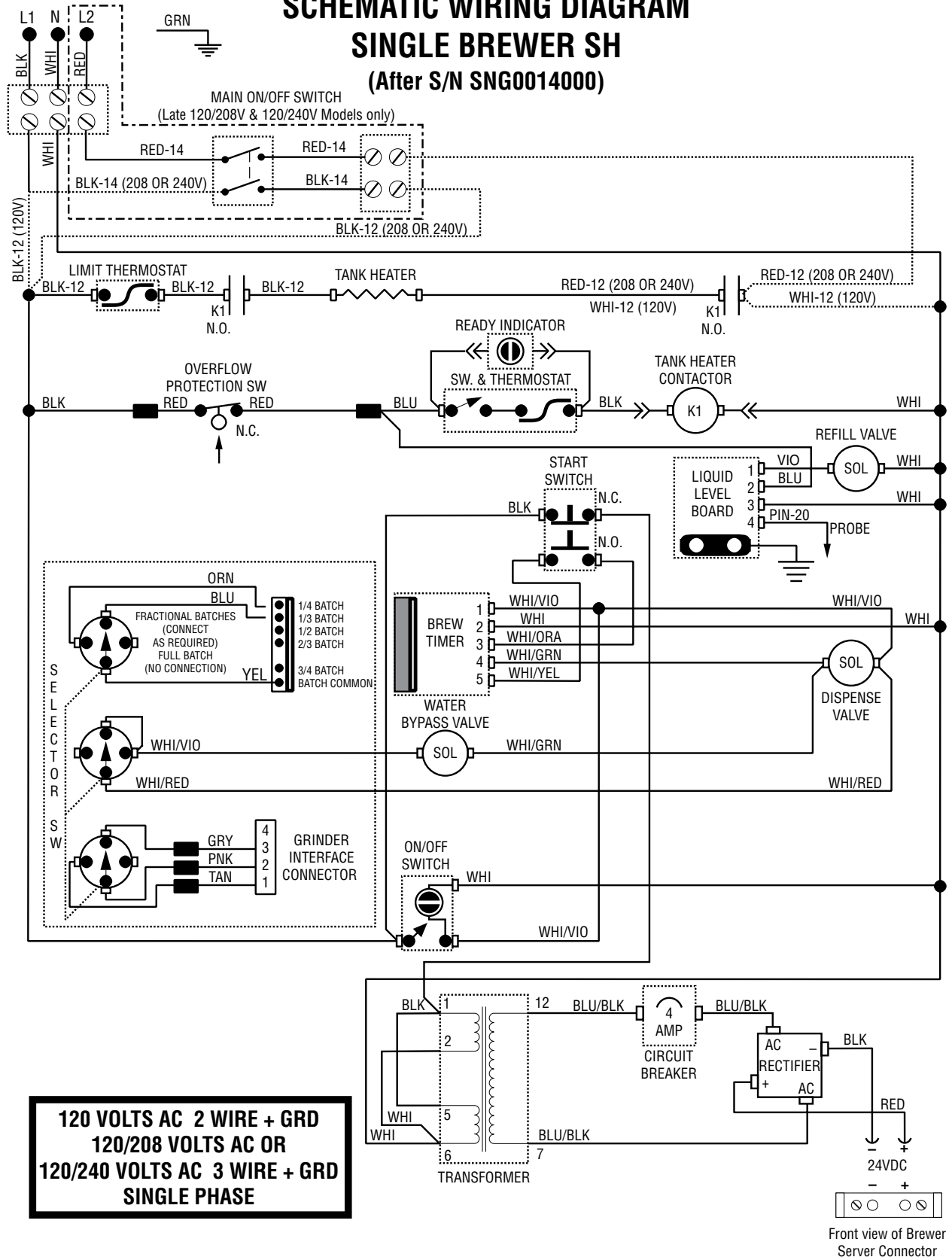

**120 VOLTS AC 2 WIRE + GRD
120/208 VOLTS AC OR
120/240 VOLTS AC 3 WIRE + GRD
SINGLE PHASE**

SCHEMATIC WIRING DIAGRAM SINGLE SH BK

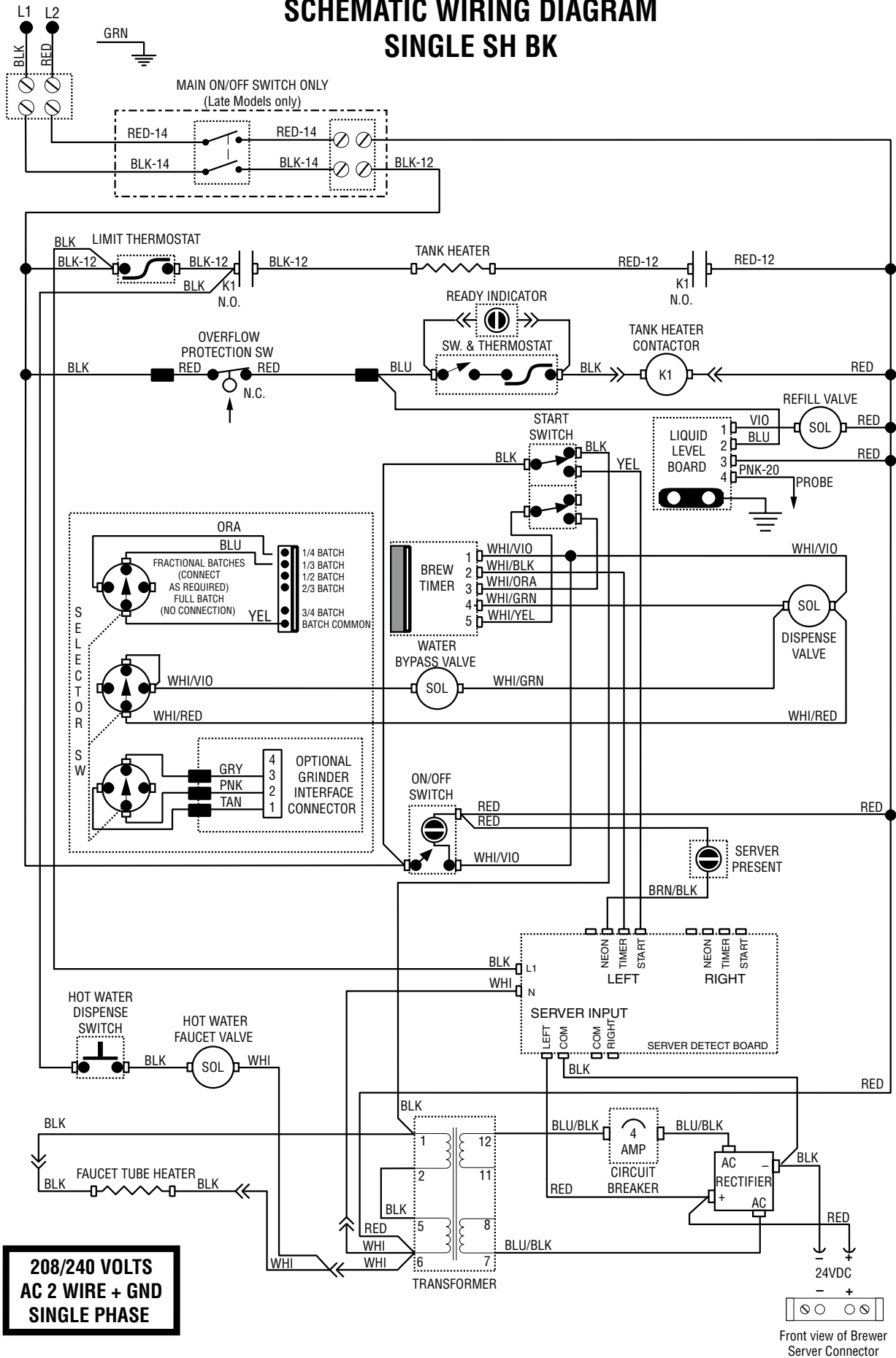

SINGLE SH BREWER W/DIGITAL BREWER CONTROL SCHEMATIC WIRING DIAGRAM

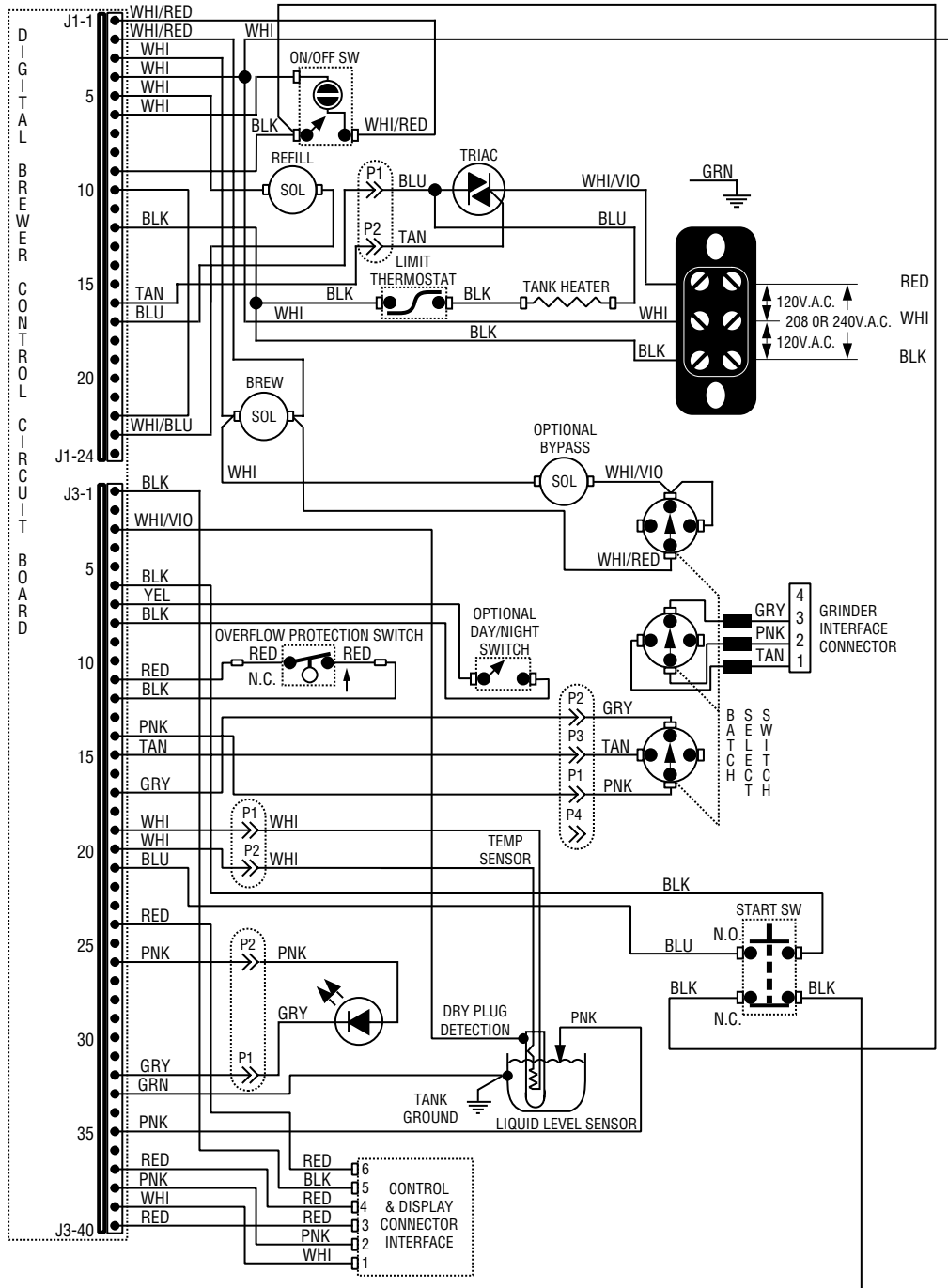

**120 VOLTS AC 2 WIRE
120/208 VOLTS AC OR
120/240 VOLTS AC 3 WIRE
SINGLE PHASE**

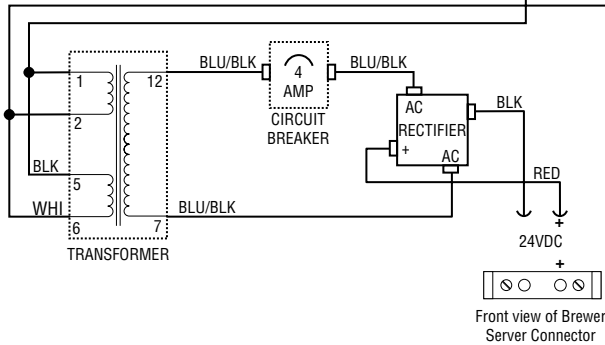

SCHEMATIC WIRING DIAGRAM DUAL BREWER (W/TWO-GRINDER INTERFACE)

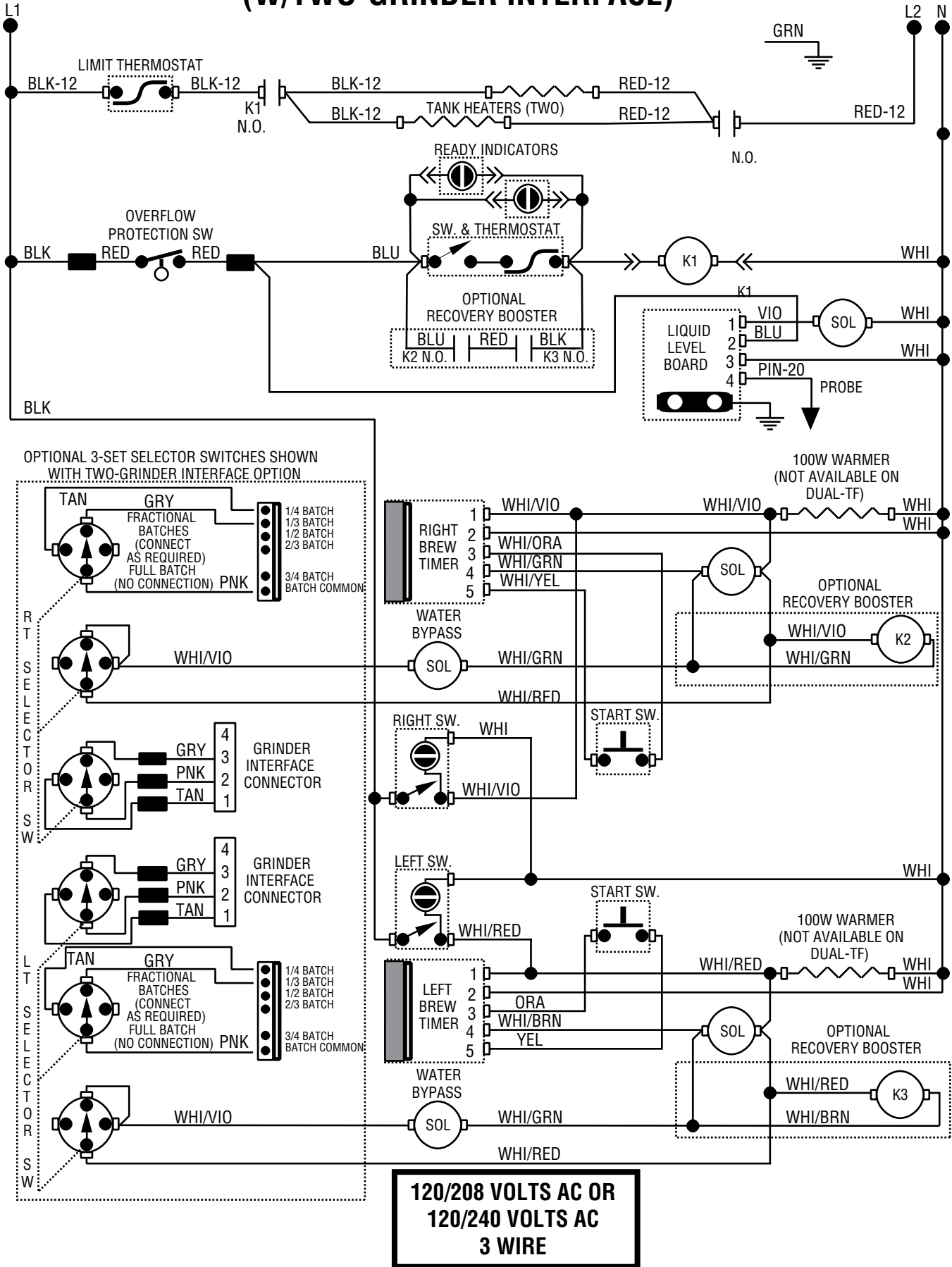

SCHEMATIC WIRING DIAGRAM DUAL-A & -B BREWER (W/TWO-GRINDER INTERFACE)

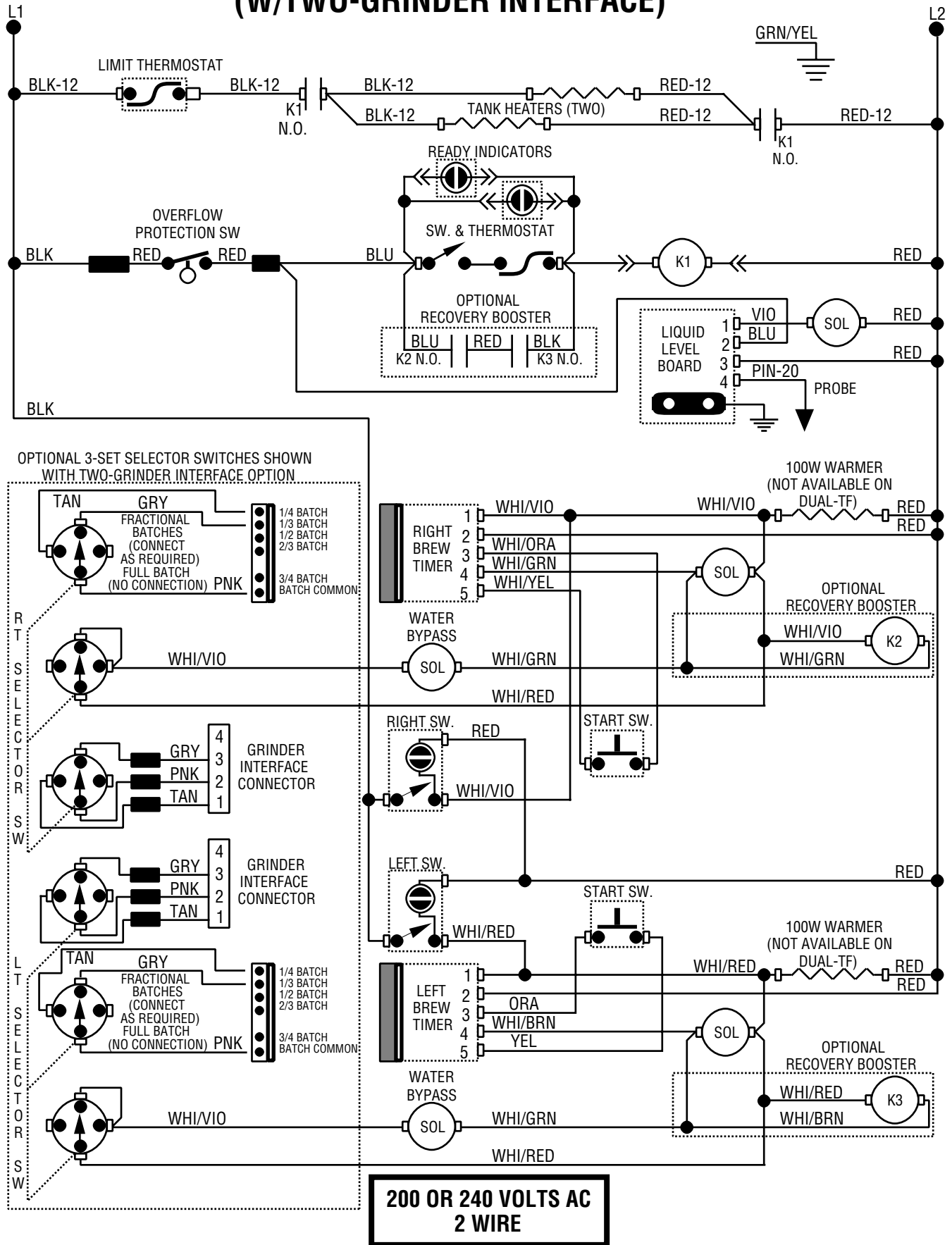

SCHEMATIC WIRING DIAGRAM DUAL BREWER (W/ONE-GRINDER INTERFACE)

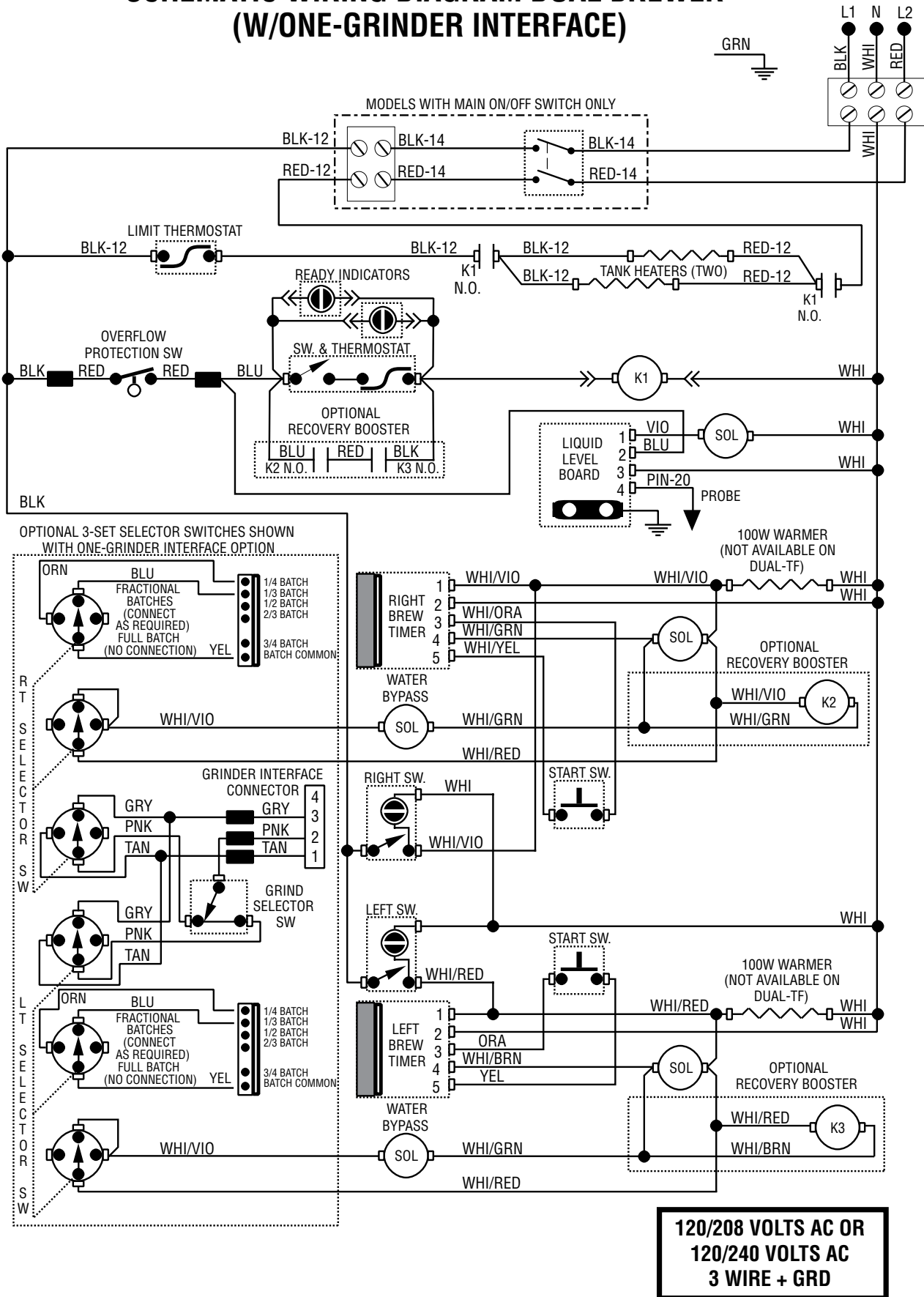

SCHEMATIC WIRING DIAGRAM DUAL-A & -B BREWER (W/ONE-GRINDER INTERFACE)

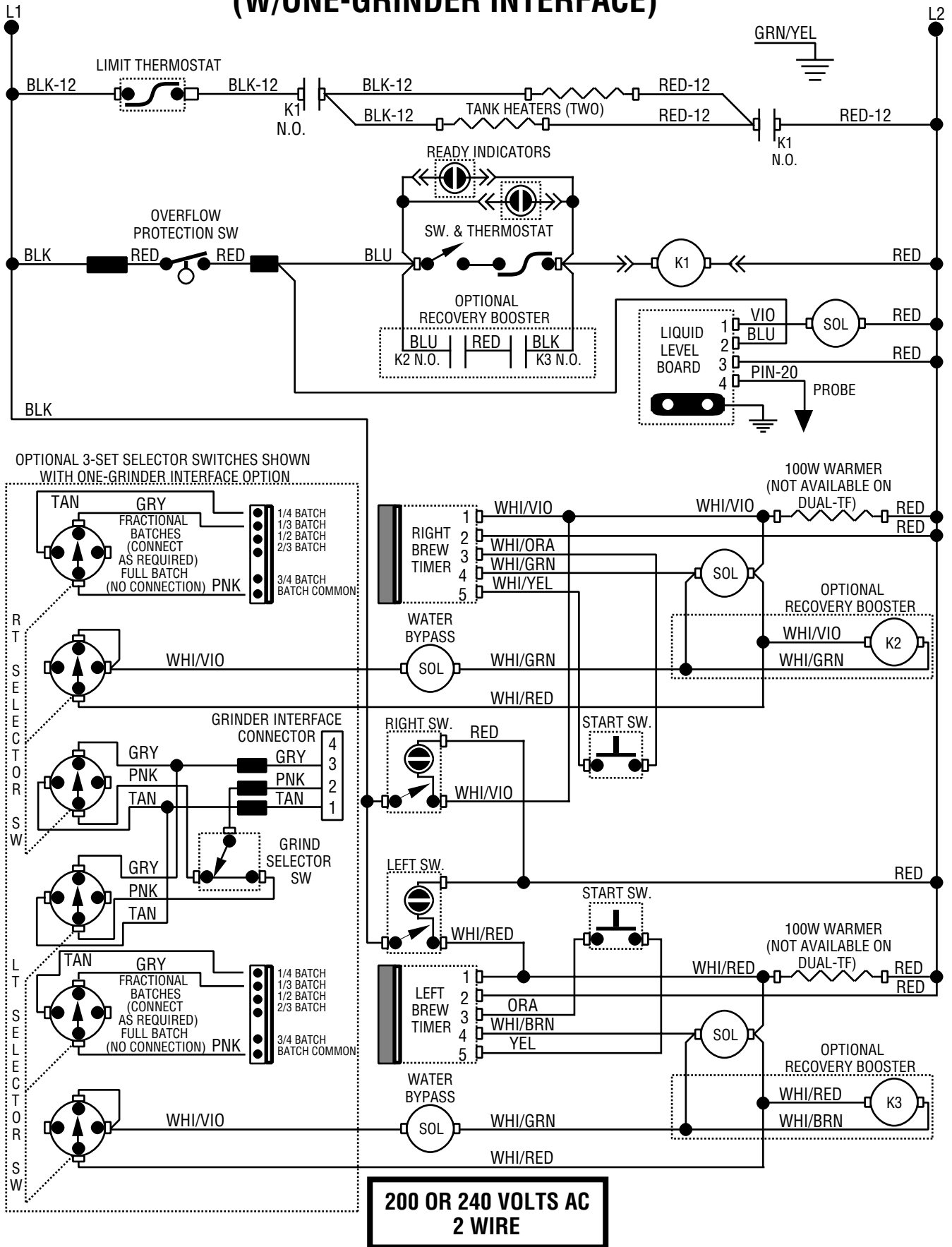

SCHEMATIC WIRING DIAGRAM DUAL BREWER W/DIGITAL BREWER CONTROL

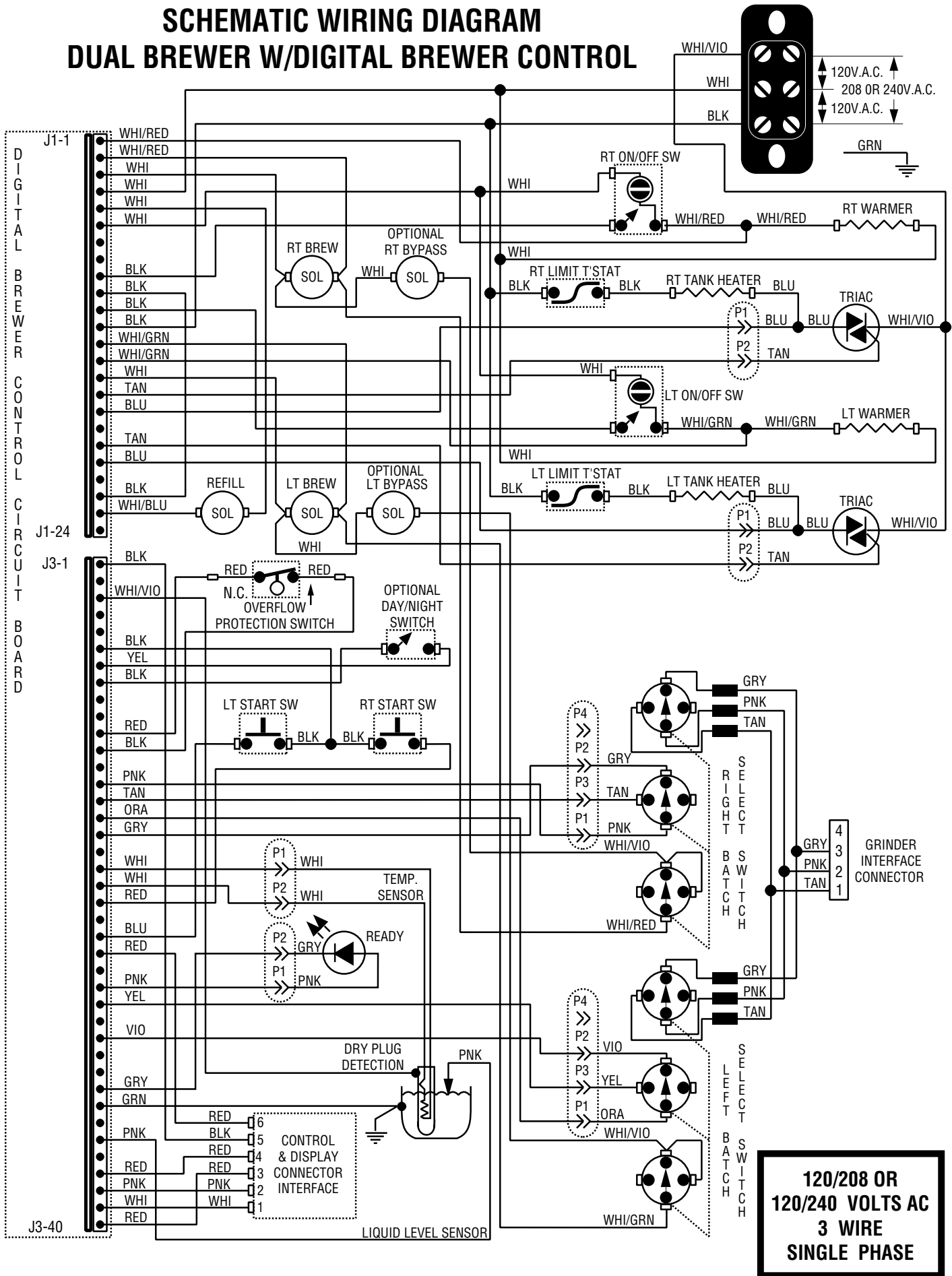

**120/208 OR
120/240 VOLTS AC
3 WIRE
SINGLE PHASE**

SCHEMATIC WIRING DIAGRAM DUAL BREWER SH (W/ONE-GRINDER INTERFACE) (Prior to S.N. DUAL026000)

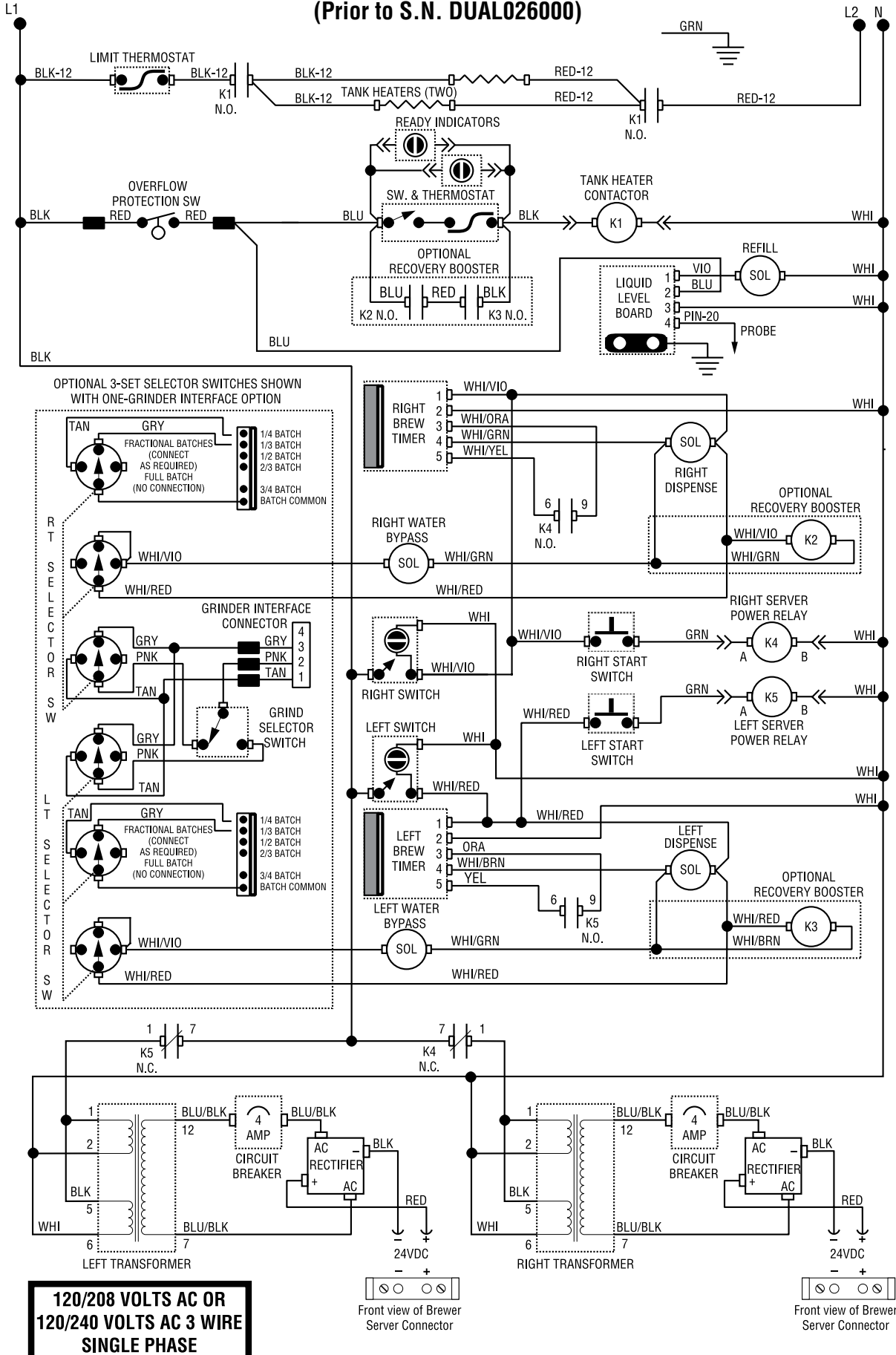

SCHEMATIC WIRING DIAGRAM DUAL BREWER SH (W/ONE-GRINDER INTERFACE) (After S.N. DUAL026000)

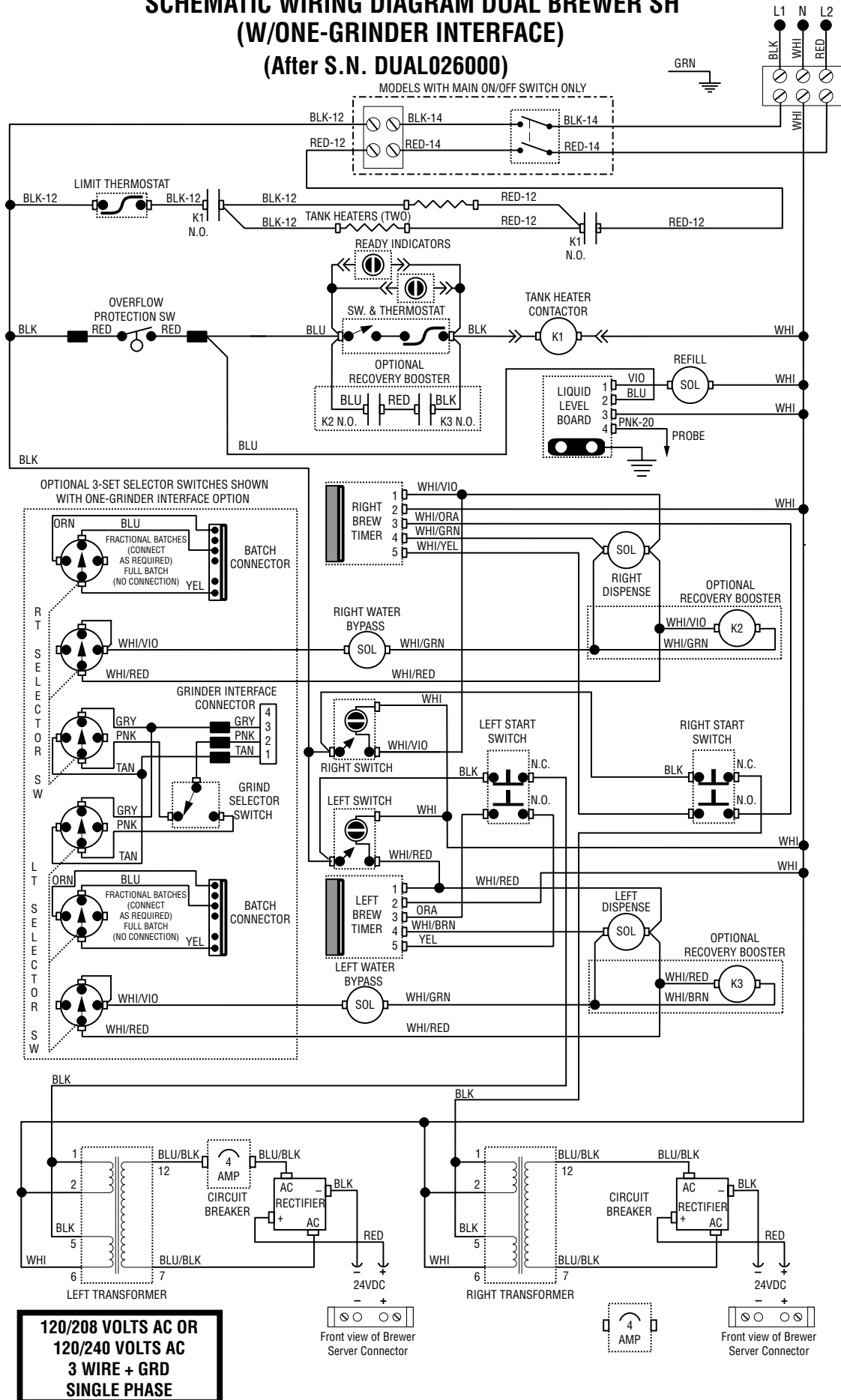

SCHEMATIC WIRING DIAGRAM DUAL (CE) BREWER (W/ONE-GRINDER INTERFACE)

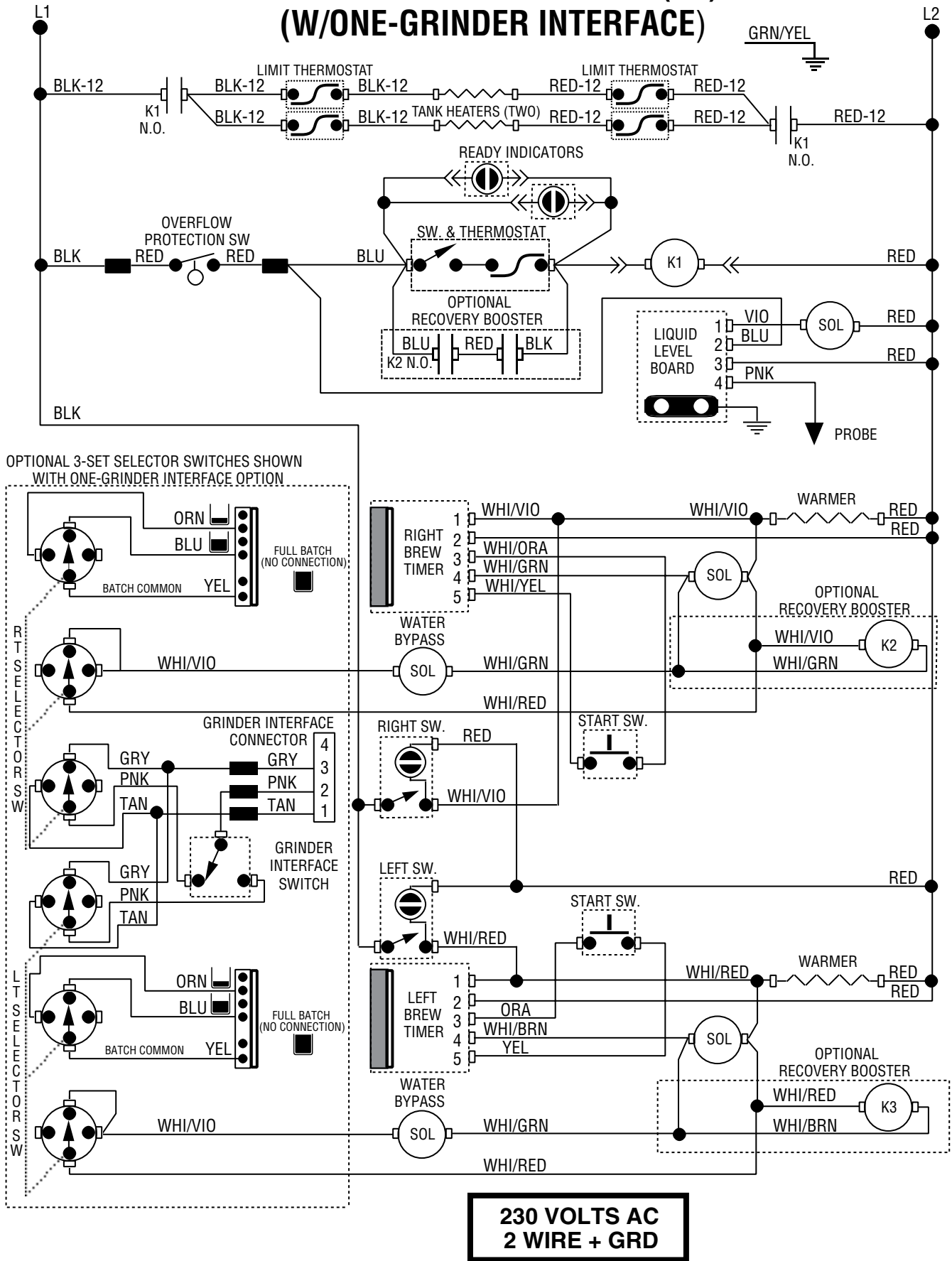

SCHEMATIC WIRING DIAGRAM DUAL SH, CE 3 PHASE W/NEUTRAL

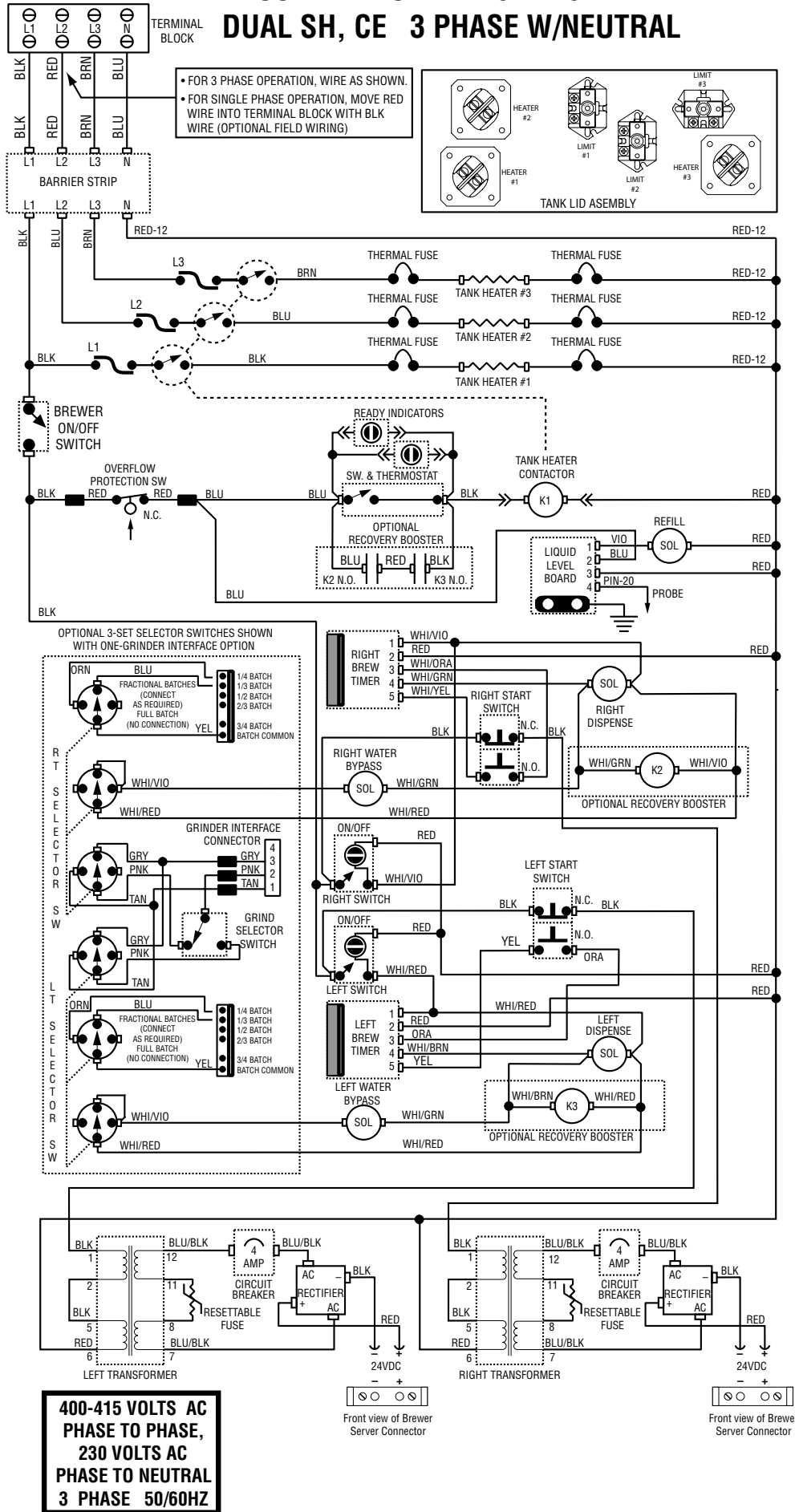

SCHEMATIC WIRING DIAGRAM DUAL SH, 230V CE (W/Thermal Safety Fuse)

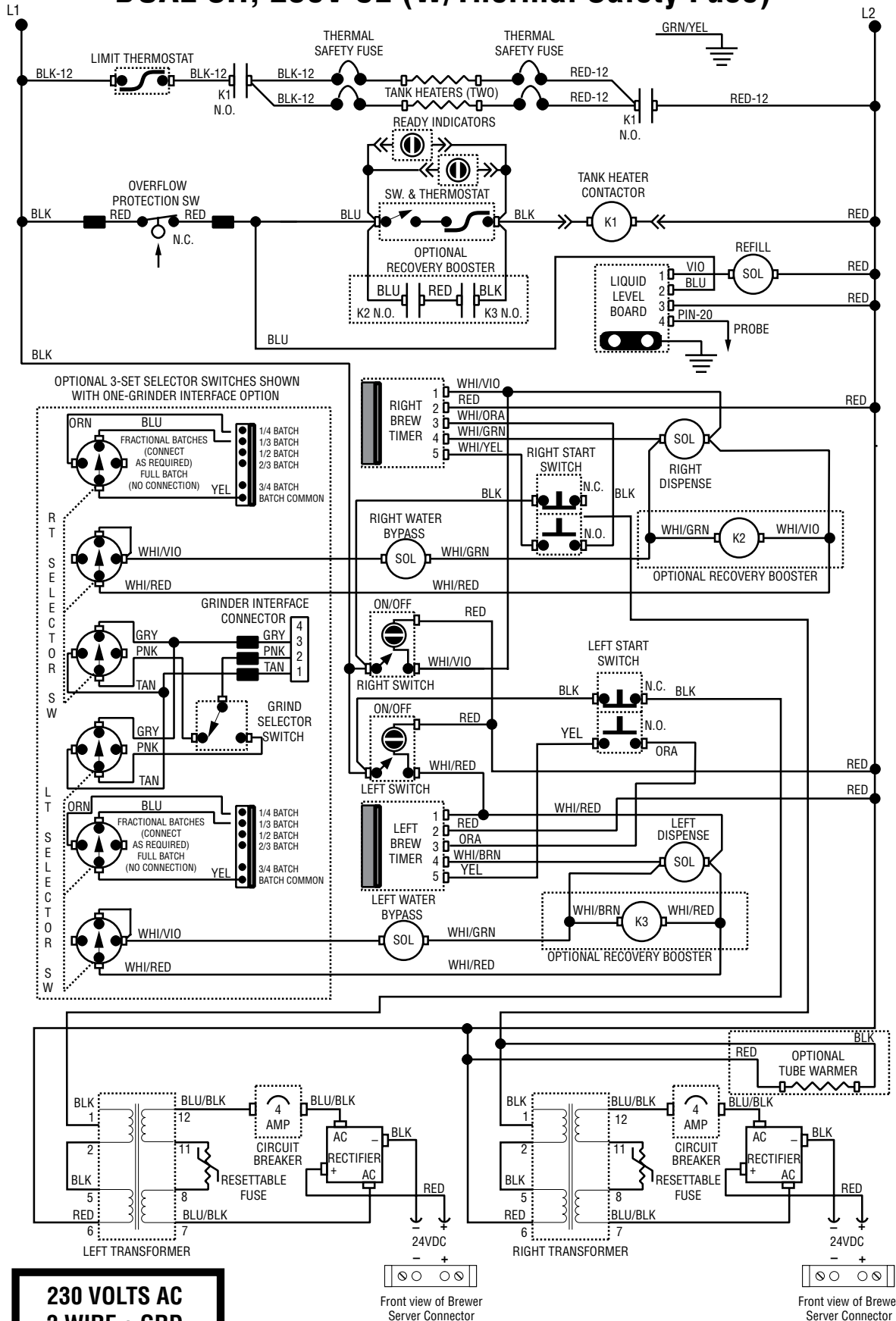

SCHEMATIC WIRING DIAGRAM DUAL SH, 230V CE (W/Limit Thermostat)

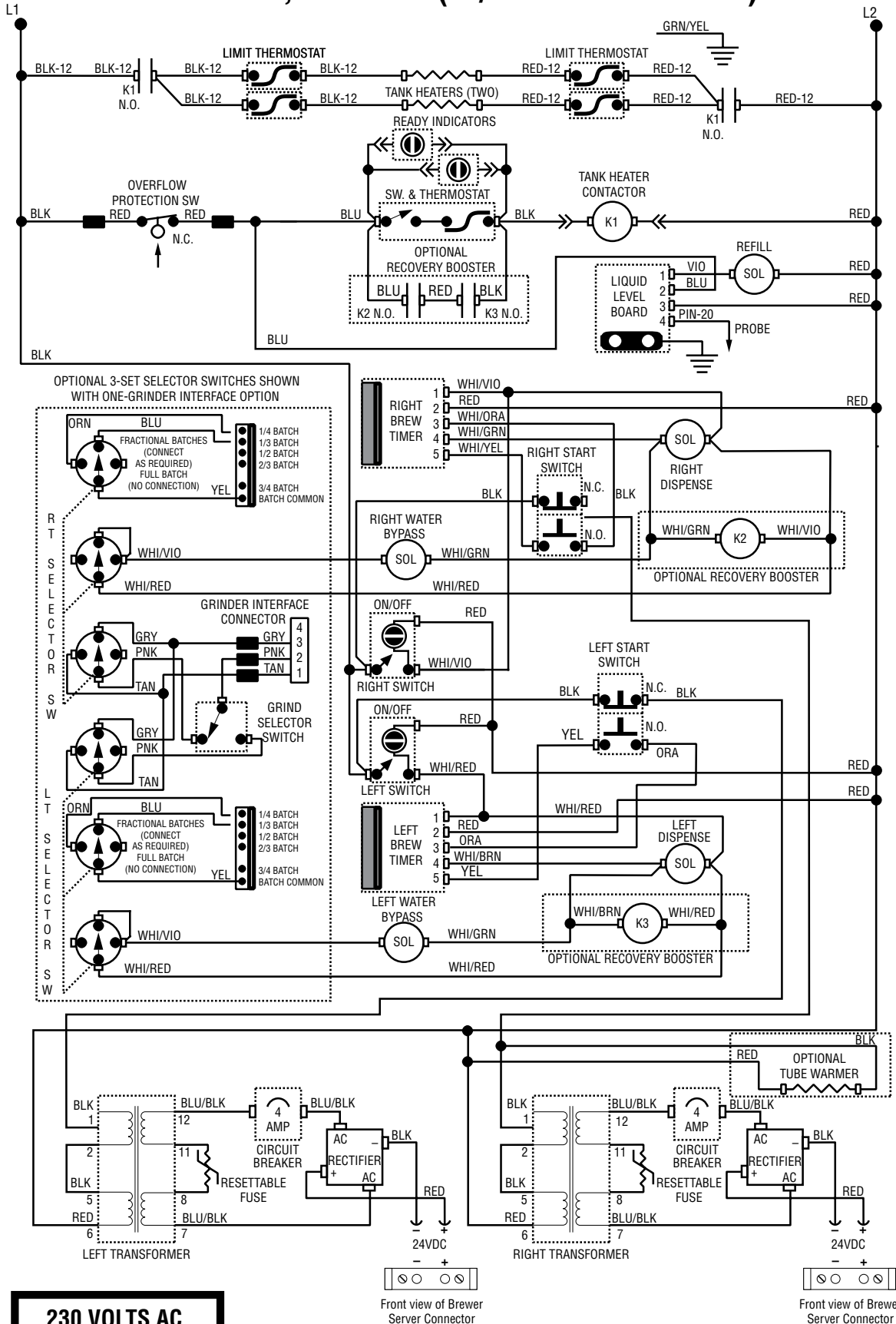

**230 VOLTS AC
2 WIRE + GRD
SINGLE PHASE**

Front view of Brewer Server Connector

Front view of Brewer Server Connector

SCHEMATIC WIRING DIAGRAM

DUAL SH, 230V CE

(Brewers W/Product #27900.0016)

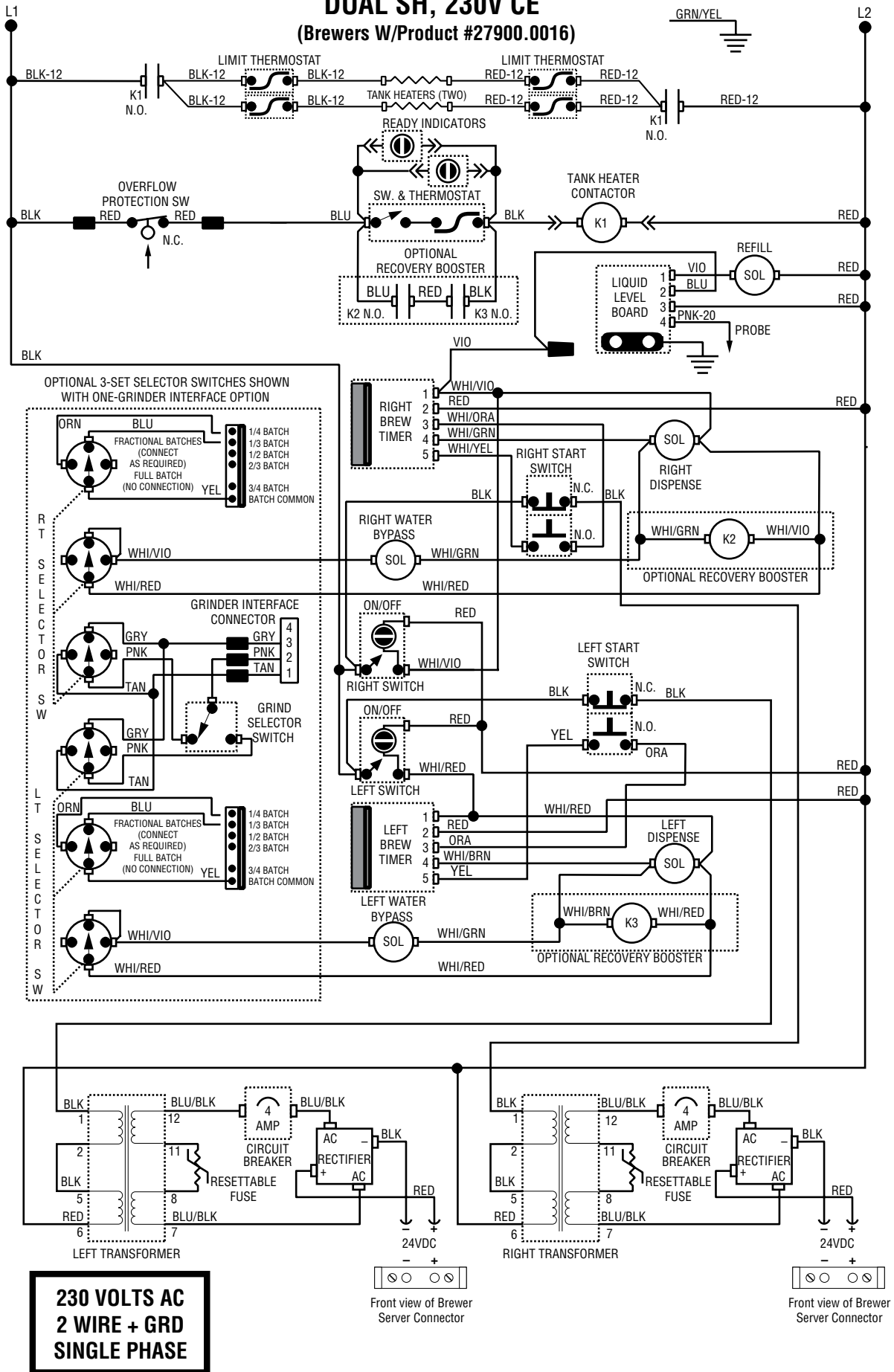

SCHEMATIC WIRING DIAGRAM DUAL SH, 230V CE (ISRAEL)

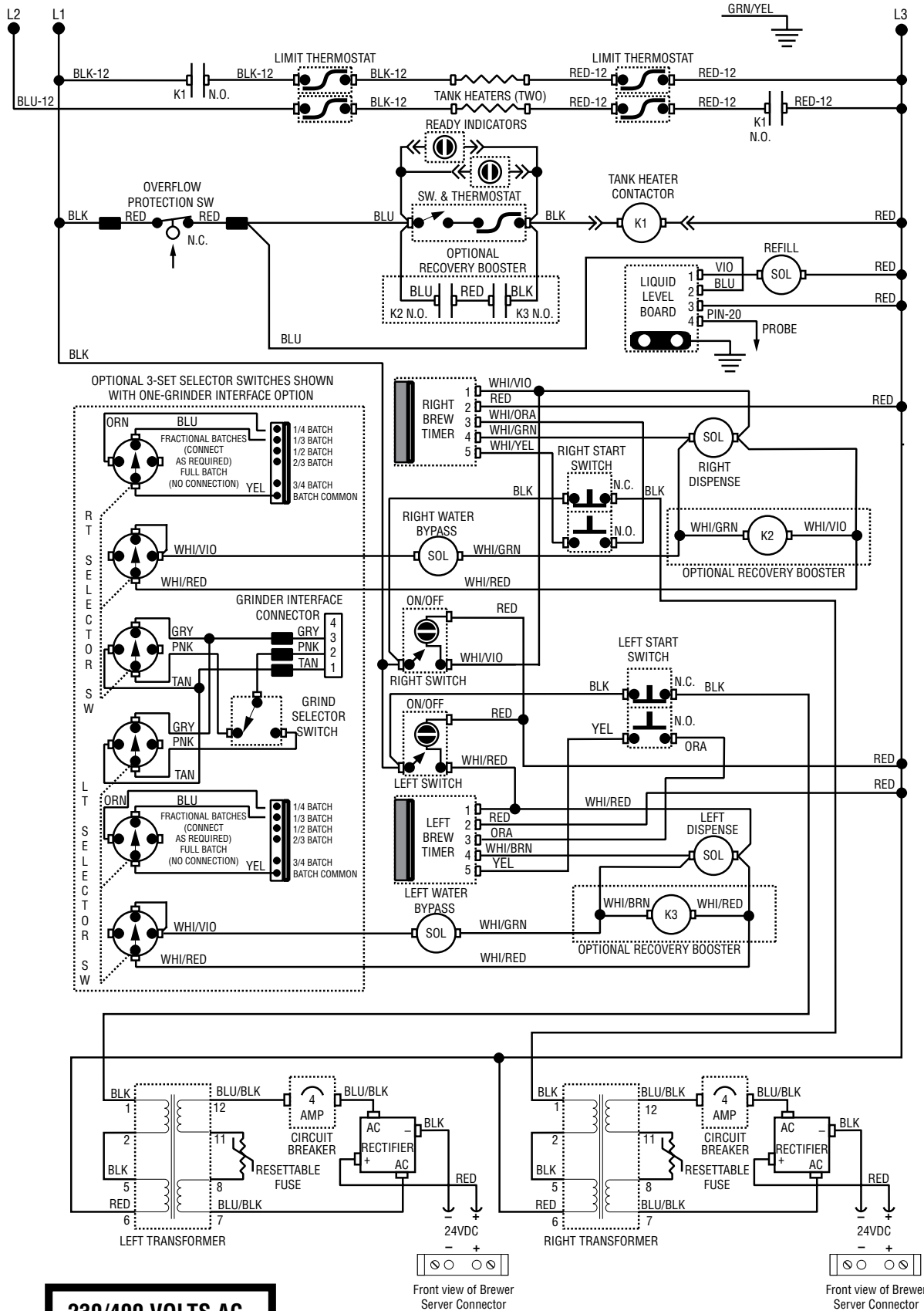

**230/400 VOLTS AC
3 WIRE + GRD
3 PHASE**