

BUNN®

Soft Heat® *Server* 1.75 Gallon

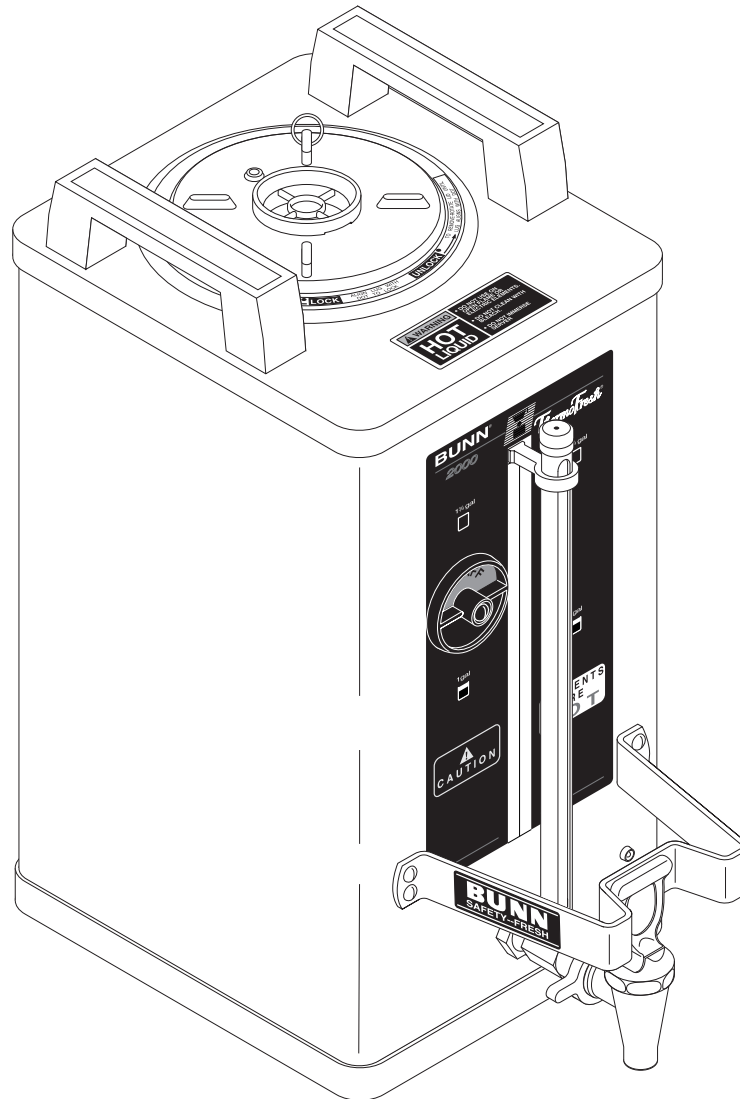

INSTALLATION & OPERATING MANUAL

BUNN-O-MATIC CORPORATION

POST OFFICE BOX 3227

SPRINGFIELD, ILLINOIS 62708-3227

PHONE: (217) 529-6601 FAX: (217) 529-6644

To ensure you have the latest revision of the manual or to obtain the illustrated parts catalog, please visit the Bunn-O-Matic website, at www.bunn.com. This is absolutely FREE, and the quickest way to obtain the latest catalog and manual updates. Contact Bunn-O-Matic Corporation at 1-800-286-6070 to obtain a paper copy of the required Illustrated Parts Catalog mailed via U.S. Postal Service.



28167.0000H 12/14 ©1997 Bunn-O-Matic Corporation

DIR Num: 28167.0000

07, January 2015

BUNN-O-MATIC COMMERCIAL PRODUCT WARRANTY

Bunn-O-Matic Corp. ("BUNN") warrants equipment manufactured by it as follows:

- 1) Airpots, thermal carafes, decanters, GPR servers, iced tea/coffee dispensers, MCR/MCP/MCA single cup brewers, thermal servers and ThermoFresh® servers (mechanical and digital) 1 year parts and 1 year labor.
- 2) All other equipment - 2 years parts and 1 year labor plus added warranties as specified below:
 - a) Electronic circuit and/or control boards - parts and labor for 3 years.
 - b) Compressors on refrigeration equipment - 5 years parts and 1 year labor.
 - c) Grinding burrs on coffee grinding equipment to grind coffee to meet original factory screen sieve analysis - parts and labor for 4 years or 40,000 pounds of coffee, whichever comes first.

These warranty periods run from the date of installation BUNN warrants that the equipment manufactured by it will be commercially free of defects in material and workmanship existing at the time of manufacture and appearing within the applicable warranty period. This warranty does not apply to any equipment, component or part that was not manufactured by BUNN or that, in BUNN's judgment, has been affected by misuse, neglect, alteration, improper installation or operation, improper maintenance or repair, non periodic cleaning and descaling, equipment failures related to poor water quality, damage or casualty. In addition, the warranty does not apply to replacement of items subject to normal use including but not limited to user replaceable parts such as seals and gaskets. This warranty is conditioned on the Buyer 1) giving BUNN prompt notice of any claim to be made under this warranty by telephone at (217) 529-6601 or by writing to Post Office Box 3227, Springfield, Illinois 62708-3227; 2) if requested by BUNN, shipping the defective equipment prepaid to an authorized BUNN service location; and 3) receiving prior authorization from BUNN that the defective equipment is under warranty.

THE FOREGOING WARRANTY IS EXCLUSIVE AND IS IN LIEU OF ANY OTHER WARRANTY, WRITTEN OR ORAL, EXPRESS OR IMPLIED, INCLUDING, BUT NOT LIMITED TO, ANY IMPLIED WARRANTY OF EITHER MERCHANTABILITY OR FITNESS FOR A PARTICULAR PURPOSE. The agents, dealers or employees of BUNN are not authorized to make modifications to this warranty or to make additional warranties that are binding on BUNN. Accordingly, statements by such individuals, whether oral or written, do not constitute warranties and should not be relied upon.

If BUNN determines in its sole discretion that the equipment does not conform to the warranty, BUNN, at its exclusive option while the equipment is under warranty, shall either 1) provide at no charge replacement parts and/or labor (during the applicable parts and labor warranty periods specified above) to repair the defective components, provided that this repair is done by a BUNN Authorized Service Representative; or 2) shall replace the equipment or refund the purchase price for the equipment.

THE BUYER'S REMEDY AGAINST BUNN FOR THE BREACH OF ANY OBLIGATION ARISING OUT OF THE SALE OF THIS EQUIPMENT, WHETHER DERIVED FROM WARRANTY OR OTHERWISE, SHALL BE LIMITED, AT BUNN'S SOLE OPTION AS SPECIFIED HEREIN, TO REPAIR, REPLACEMENT OR REFUND.

In no event shall BUNN be liable for any other damage or loss, including, but not limited to, lost profits, lost sales, loss of use of equipment, claims of Buyer's customers, cost of capital, cost of down time, cost of substitute equipment, facilities or services, or any other special, incidental or consequential damages.

392, A Partner You Can Count On, Air Infusion, AutoPOD, AXIOM, BrewLOGIC, BrewMETER, Brew Better Not Bitter, BrewWISE, BrewWIZARD, BUNN Espresso, BUNN Family Gourmet, BUNN Gourmet, BUNN Pour-O-Matic, BUNN, BUNN with the stylized red line, BUNNlink, Bunn-O-Matic, Bunn-O-Matic, BUNNserve, BUNNSERVE with the stylized wrench design, Cool Froth, DBC, Dr. Brew stylized Dr. design, Dual, Easy Pour, EasyClear, EasyGard, FlavorGard, Gourmet Ice, Gourmet Juice, High Intensity, iMIX, Infusion Series, Intellisteam, My Café, Phase Brew, PowerLogic, Quality Beverage Equipment Worldwide, Respect Earth, Respect Earth with the stylized leaf and coffee cherry design, Safety-Fresh, savemycoffee.com, Scale-Pro, Silver Series, Single, Smart Funnel, Smart Hopper, SmartWAVE, Soft Heat, SplashGard, The Mark of Quality in Beverage Equipment Worldwide, ThermoFresh, Titan, trifacta, TRIFECTA (stylized logo), Velocity Brew, Air Brew, Beverage Bar Creator, Beverage Profit Calculator, Brew better, not bitter., Build-A-Drink, BUNNSource, Coffee At Its Best, Cyclonic Heating System, Daypart, Digital Brewer Control, Element, Milk Texturing Fusion, Nothing Brews Like a BUNN, Picture Prompted Cleaning, Pouring Profits, Signature Series, Sure Tamp, Tea At Its Best, The Horizontal Red Line, Ultra are either trademarks or registered trademarks of Bunn-O-Matic Corporation. The commercial trifacta® brewer housing configuration is a trademark of Bunn-O-Matic Corporation.

INTRODUCTION

This server allows portable storage and dispensing of up to 1¾ gallon of hot beverage at remote locations. Coffee can be brewed directly into the server without removing the cover when used with a BUNN® Dual® SH or Single® SH coffee brewer. The spill-resistant design lessens the chance of hot beverage burns and splashes.

USER NOTICES

The notices on this server should be kept in good condition. Replace unreadable or damaged labels.



#26186.0000

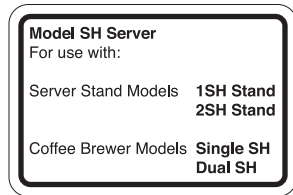

#28056.0000



#28151.0000

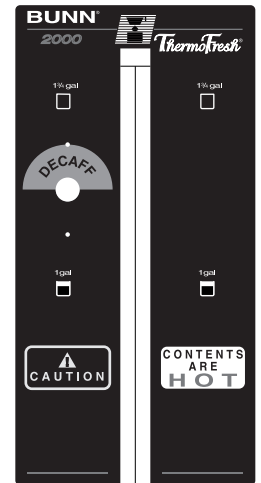

#26178.0001

USING THE SERVER

Simply select the desired brew batch size with the rotary switch on the brewer and place the server beneath the funnel dripout. One half, one, or one and three-quarter gallon batches may be brewed into the 1¾ gallon server. Press and release the START switch to initiate a brew cycle. Place the decaffeinated coffee indicator in the proper position for the type of coffee being brewed. Fresh HOT coffee is immediately available at the faucet.

NOTE – Be careful not to overfill the server.

The power indicator will remain on for thirty minutes from power up then begin to flash. The flashing indicator alerts the operator that the product is thirty minutes old.

CLEANING

NOTE: Bunn-O-Matic recommends the three step method for cleaning and sanitizing the server. The 3 step method consists of hot soapy water using a mild, non-citrus detergent, a fresh water rinse and an aqueous sanitizing solution using a non-chlorine sanitizer. Do not submerge the server. Failure to follow the recommended cleaning procedures can cause corrosion to the stainless steel surface and damage the vacuum seal. **USE OF ANY CHLORINATED PRODUCT VOIDS THE FACTORY WARRANTY.**

1. Turn the entire lid assembly one-quarter turn counterclockwise to remove it for daily dishwasher cleaning.
2. Remove the cap from the lid assembly by unscrewing in a counterclockwise direction. Remove the gasket from the bottom side of the lid assembly.
3. Fill server with non-chlorine cleaning solution and thoroughly clean inside of server using a SOFT, Non-abrasive cloth or brush. Drain and thoroughly rinse using fresh water.
4. Fill server with non-chlorine sanitizing solution and let server set for no more than five (5) minutes, then drain through fully open faucet.
5. Clean the airvents with the small brush provided (26367.0000) using a cleaning product and water solution.



CLEANING - continued

6. Clean the inlet tube with the medium-size brush using the cleaning product solution. Clean gasket with cleaning product solution.



7. Rinse all lid assembly components well. Reassemble lid components.



8. Unscrew the sight gauge cap. Remove the sight gauge glass tube and washers.



9. Clean the sight gauge with the large brush (00675.0000) and reassemble.



10. Turn the faucet wingnut in a counter-clockwise direction and remove the faucet from the dispenser. Unscrew the faucet cap from the faucet body and disassemble all faucet parts.



11. Transfer all the faucet parts to a three compartment sink for cleaning. Fill the first sink with a soap solution using a mild detergent, the second sink is used for clean rinse (Hot Water), and the third is used for a sanitizer solution (75° F warm water and approved sanitizer).



12. Use a small brush (00674.0000) to thoroughly scrub the faucet body.



CLEANING - continued.

13. Allow the parts to soak in the sanitizer solution for a minimum of five (5) minutes. Remove the faucet parts from the sanitizer solution and allow to air-dry overnight.



14. Reassemble faucet.

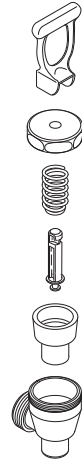

15. Clean the faucet shank with the supplied brush (00674.0000).

16. Re-attach faucet to server faucet shank. When reassembling - CAUTION: DO NOT over-tighten faucet wing nut - HAND TIGHTEN ONLY.

17. Clean the entire outside surface of the server using a clean SOFT, Non-abrasive cloth dampened with any mild, non-citrus, non-abrasive, liquid detergent.

18. Thoroughly rinse the entire server after cleaning.

SCHEMATIC WIRING DIAGRAM FOR SH SERVER

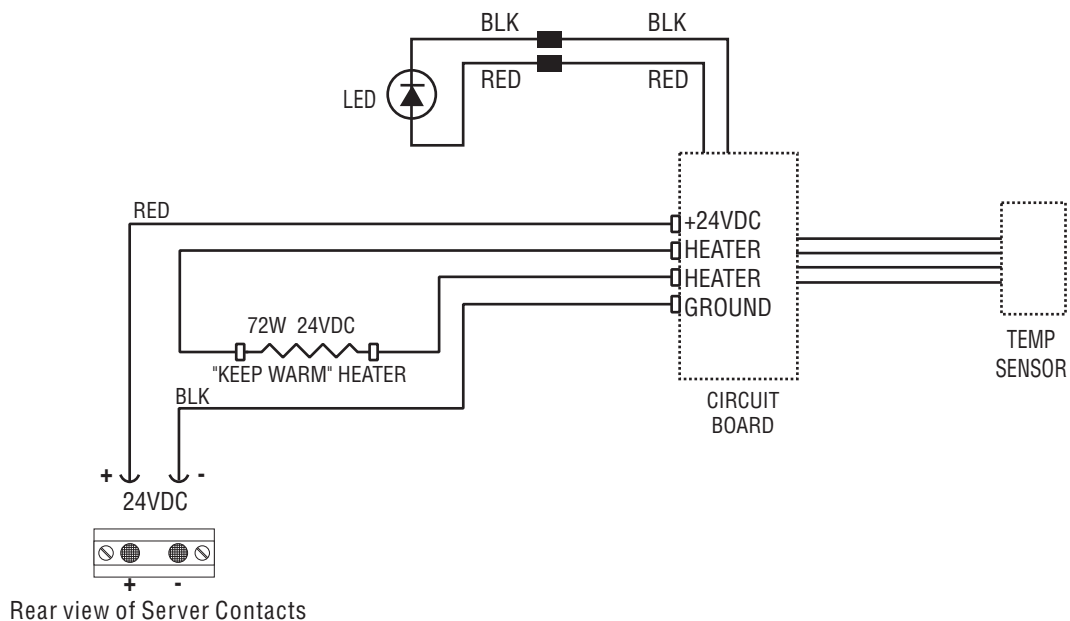

24 VOLTS DC