

# DTU03 REPLACEMENT PARTS

ITEM	PART NAME	18" UNIT - PART #	26" UNIT - PART #
1	FILTER - ALUMINUM MEDIA & FRAME	80ALM1F4ALM-0516	80ALM1F4ALM-0524
2	END CAP	40DTU000CVR-U-BP	40DTU000CVR-U-BP
3	WALL BRACKET - ADJUSTABLE	66DTU008WMB	66DTU008WMB
4	WALL BRACKET - SPANNING ARM	40DTU000WMB-U-SA	40DTU000WMB-U-SA
5	HARDWARE - SPANNING ARM - BOLT	530300140034CS-HHF5	530300140034CS-HHF5
6	HARDWARE - SPANNING ARM - NUT	53010014WZ	53010014WZ
7	WALL BRACKET - STD.	40DTU000WMB-U	40DTU000WMB-U
8	THUMBSCREW - PIVOT	530300140038MS-TH-1F2	530300140038MS-TH-1F2
9	THUMBSCREW - DOGPOINT	530300140916MS-TH-DP-1F2	530300140916MS-TH-DP-1F2
10	ELECTRIC HEATER 2KW, 120VOLT (optional)	11DTU018A002A	11DTU026A002A
11	ROCKER SWITCH, 20 AMP - AMBIENT UNIT (FAN ON/OFF)	33A020B-DS	33A020B-DS
11	ROCKER SWITCH, 20 AMP - ELEC. HEATED UNIT (FAN-OFF-FAN/HEAT)	33A020B-DD	33A020B-DD
12	INLET SCREEN	08DTU018IS	08DTU026IS

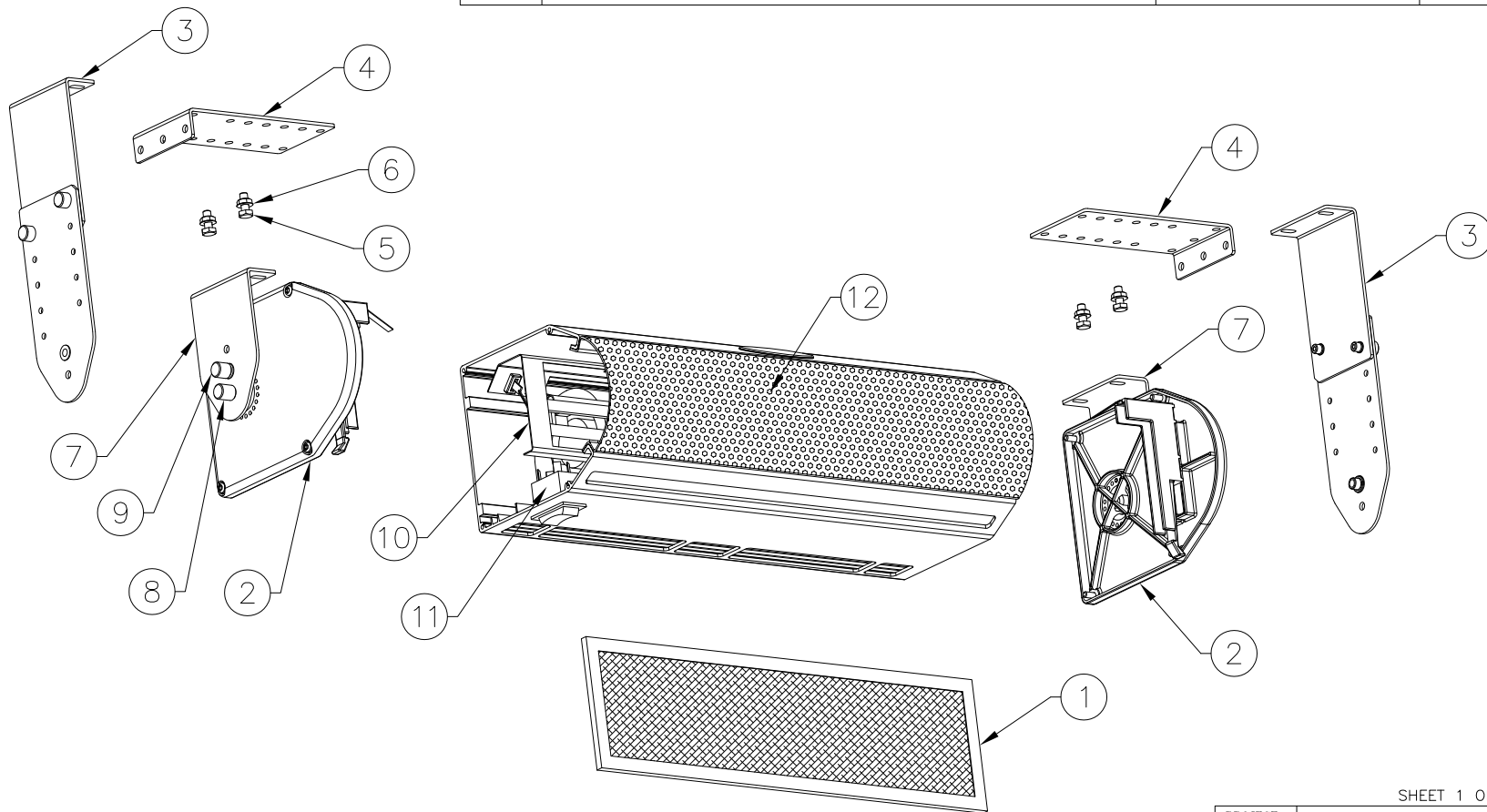

SHEET 1 OF 1

PROJECT		
LOCATION		
ARCHITECT		
ENGINEER		REV. -
DWG. NO.	DTU03-RP	TITLE: <b>BERNER</b> MODEL DTU03 AIR CURTAIN REPLACEMENT PARTS
DATE	04NOV14	
BY	S. Beil	BERNER INTERNATIONAL CORP. NEW CASTLE, PA.
REPLACES	-	
BY	-	