

**BLODGETT**<sup>®</sup>

**BLODGETT**<sup>®</sup>

**BLODGETT**<sup>®</sup>

**BLODGETT**<sup>®</sup>

**BLODGETT**<sup>®</sup>

**BLODGETT**<sup>®</sup>

**BLODGETT**<sup>®</sup>

**BLODGETT**<sup>®</sup>

**BLODGETT**<sup>®</sup>

**BLODGETT**<sup>®</sup>

**BLODGETT**<sup>®</sup>

---

**BLODGETT**<sup>®</sup>

**MT3240 SERIES  
CONVEYOR OVENS  
SERVICE AND REPAIR MANUAL**

**BLODGETT OVEN COMPANY**

[www.blodgett.com](http://www.blodgett.com)

50 Lakeside Avenue, Box 586, Burlington, Vermont 05402 USA Telephone (802) 658-6600 Fax: (802)864-0183

PN M9911 Rev C (11/01)

© 2001 – G.S. Blodgett Corporation

**TABLE OF CONTENTS**

---

*This page intentionally left blank.*

# TABLE OF CONTENTS

---

<b>1. INTRODUCTION</b>	
Oven Specifications .....	1-1
Ventilation Requirements .....	1-1
Electrical Specifications .....	1-3
Gas Specifications .....	1-5
<b>2. OPERATION</b>	
Computer Controller .....	2-1
Sequence of Operation .....	2-3
MT3240G Domestic and General Export – M4193 Rev C .....	2-3
MT3240E domestic and General Export – M4196 Rev C .....	2-5
MT3240G Australia – M4174 Rev A .....	2-6
MT3240G CE – M4172 Rev C .....	2-8
MT3240e CE – M6509 Rev C .....	2-10
Oven Adjustments for Cooking .....	2-17
<b>3. CALIBRATION AND ADJUSTMENT</b>	
Convection Blower Motors .....	3-1
Regulated Gas Pressure .....	3-2
Computer Controller Configuration .....	3-3
Temperature Calibration .....	3-5
Belt Speed Calibration .....	3-6
Closed Loop System .....	3-6
Open Loop System – Single belt .....	3-7
Open Loop System – Twin Belt .....	3-8
Rerating the Appliance .....	3-9
Checking the Firing Rate .....	3-10
<b>4. TROUBLESHOOTING</b>	
DC Drive System .....	4-1
Computer Control System .....	4-2
Heating System .....	4-3
Convection System .....	4-5
Reference Tables .....	4-7
Heating Element Resistance .....	4-7
Probe Resistance vs Temperature .....	4-7

## TABLE OF CONTENTS

---

*This page intentionally left blank.*

*CHAPTER 1*

---

***INTRODUCTION***

---

## OVEN SPECIFICATIONS

### VENTILATION REQUIREMENTS

A mechanically driven ventilation system is required for the removal of excess heat and cooking vapors. For gas models, a ventilation system is also required for the removal of the products of gas combustion. The necessity for a properly designed and installed ventilation system cannot be over emphasized.

The following are general recommendations and guidelines for good ventilation. Your specific application may require the services of a ventilation engineer or consultant

The ventilation hood must work well with the building heating, ventilation and air conditioning (HVAC) system. The hood exhaust and the supply air flows should be sized appropriately. Supply air must be provided by either the hood system or the building HVAC system in order to prevent a negative pressure in the oven area. Supply air should replace approximately 80% of the air flow exhausted by the hood. The table below can be used as a guideline, but the correct air flow values depend on the efficiency of the hood design, the amount of air flow around the oven, and the current air flow in and out of the kitchen or oven area (for existing facilities).

SINGLE	DOUBLE	TRIPLE
<b>Exhaust Volume – CFM (M<sup>3</sup>/min)</b>		
800-1000 (23-28)	1200-1600 (34-46)	2000-2400 (57-68)
<b>Supply Requirements – CFM (M<sup>3</sup>/min)</b>		
640-800 (18-23)	960-1280 (27-36)	1600-1920 (46-54)

TABLE 1

Ideally, supply air is provided through the building HVAC system or, secondly, through the hood with an in-line tempering unit. Air supplied directly from outside the building to the kitchen or oven area, non-

tempered, can be used as supply air but the design must accommodate potential operational and environmental drawbacks.

*NOTE: In NO case should supply air blow at or near the cooking chamber openings as that would adversely affect the cooking consistency and the reliability of the oven.*

The hood should be sized to completely cover the equipment plus an overhang of at least 6" (15cm) on all sides not adjacent to a wall. The distance from the floor to the lower edge of the hood should not exceed 7' (2.1m). See FIGURE 1.

#### U.S. and Canadian installations

Refer to your local ventilation codes. Requirements may vary by city, county, province or state. In the absence of local codes, refer to the National ventilation code titled, "Standard for the Installation of Equipment for the Removal of Smoke and Grease Laden Vapors from Commercial Cooking Equipment", NFPA-96-Latest Edition.

#### General export installations

Installation must conform with Local and National installation standards. Local installation codes and/or requirements may vary. If you have any questions regarding the proper installation and/or operation of your Blodgett oven, please contact your local distributor. If you do not have a local distributor, please call the Blodgett Oven Company at 0011-802-860-3700.

#### WARNING:

**Failure to properly vent the oven can be hazardous to the health of the operator and may result in operational problems, unsatisfactory baking and possible damage to the equipment.**

**Damage sustained as a direct result of improper ventilation will not be covered by the Manufacturer's warranty.**



## MT3240 Series

---

### ELECTRICAL SPECIFICATIONS

#### MT3240G

##### U.S. and Canadian installations

The MT3240G requires a 15 Amp, 60HZ, 1 $\Phi$ , 208-240VAC, 4 wire service consisting of L1, L2, neutral and ground. Wiring from the power source to these units must be a minimum of #16 AWG CU. stranded wire or larger.

Single phase units MUST NOT be connected to the high leg of a three phase system. The high leg refers to a potential of 240 volts between one phase and neutral. The remaining two legs have a potential of 120 volts between each phase and neutral.

##### General export installations

The MT3240G requires a 15 Amp, 50Hz, 1 $\Phi$ , 220-240 VAC, 3 wire service consisting of L1, neutral and ground. Use 90°C wire and size wire according to local codes.

##### CE Approved installations

Connect exhaust fan connector 1 and 2. See FIGURE 2.

Connect phase + neutral + ground .

##### **WARNING!!**

**Incorrect single phase wiring may result in extensive damage to electrical components and fire in the electrical box.**

#### MT3240E

##### U.S. and Canadian installations

The MT3240E requires a 80 amp, 60 HZ, 3 $\Phi$ , 208-240 VAC 4 wire service consisting of L1, L2, L3, and ground. Use 90°C wire and size to National Electric or local codes.

##### General export installations

The MT3240E requires a 56 amp, 50 HZ, 3 $\Phi$ , 220-240 VAC, 4 wire service consisting of L1, L2, L3 and ground. Use 90°C wire and size to National Electric or local codes.

##### CE Approved installations

Connect the oven to a separate group 230V, 50 hz with rigid connection and circuit breaker. The circuit breaker should disconnect all poles, including neutral with a contact separation of at least 3 mm.

Connect L1 + L2 + L3 + neutral + ground.

THE BLODGETT OVEN COMPANY CANNOT ASSUME RESPONSIBILITY FOR LOSS OR DAMAGE SUFFERED AS A RESULT OF IMPROPER INSTALLATION.

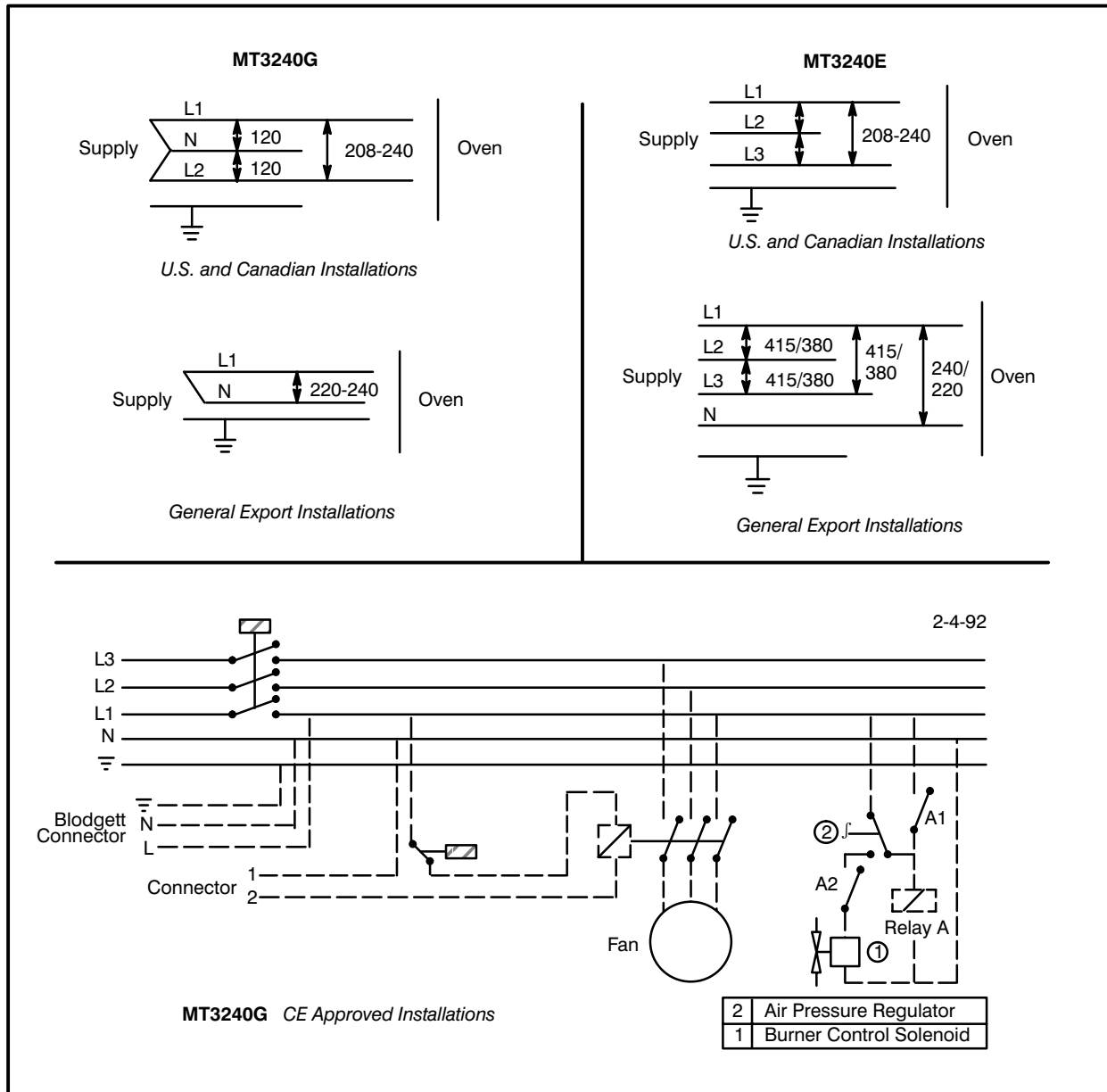

FIGURE 2

# MT3240 Series

## GAS SPECIFICATIONS

### GAS CONNECTIONS

#### Domestic and General Export installations

The gas line should be large enough to accommodate the peak demand of all the gas appliances. TABLE 2 reflects a straight line, 50 foot run with no coupling restrictions and no other appliances drawing service. Gas line installations MUST conform to National Fuel Gas Code NFPA 54/ANSI Z223.1 Sec. 1.4 (Latest Edition). TABLE 2 should be used as a guideline only.

*NOTE: For any pipe runs over 50 feet (15 m), consult the factory.*

#### CE approved installations

1. Connect the oven to the gas line with the proper type of gas according to Local and National Installation Standards. See TABLE 2.

### GAS REQUIREMENTS

The firing rate for both the MT3240G is 100,000 BTU/Hr. (29.3 kW/Hr.) (105 MJ/hr)

*NOTE: For natural gas meter sizing, consult your local gas company to ensure that your meter will provide the proper supply.*

#### Installations within the U.S.

1. Add the total BTU's/hr of all the gas appliances.
2. Convert BTU's to cubic ft/hr using the formula  
Cu Ft/Hr = 1000 BTU/Hr for natural gas.
3. Size the meter accordingly.

#### Installations outside the U.S.

1. Add the total M<sup>3</sup>/min of all the appliances.
2. Size the meter accordingly.

DOMESTIC AND GENERAL EXPORT						
	Natural Gas			Propane Gas		
<b>Gas Line Sizing</b>						
Single	3/4" line			3/4" line		
Double	1-1/4" line			1" line		
Triple	1-1/4" line			1-1/4" line		
<b>Orifice Size</b>	#X			#X		
<b>Incoming Gas Pressure</b>	W.C.	kPa	mbar	W.C.	kPa	mbar
Static	7"	1.74	17.4	12.5"	3.11	31.1
Operational	5.5"	1.36	13.7	11"	2.73	27.4
CE APPROVED UNITS						
Type of Gas	Inlet Pressure mbars	Burner Pressure mbars	Injector Diameter mm	Air Opening mm	Pilot Injector mm	Standard Delivery Value kW (H <sub>s</sub> )
G25	25	12	4,8	8	2 x 0,63	31,7 Nat. Gas
G20	20	8	4,8	8	2 x 0,63	31,7 Nat. Gas
G20/G25	20/25	Totally Inscrewed Pressure Regulator	4,8	8	2 x 0,63	31,7 Nat. Gas
G30	30/50	17	2,8	8	2 x 0,30	31,7 Butane
G31	30/37/50	24	2,8	8	2 x 0,30	31,7 Propane

TABLE 2

*CHAPTER 2*

---

***OPERATION***

**COMPUTER CONTROLLER**

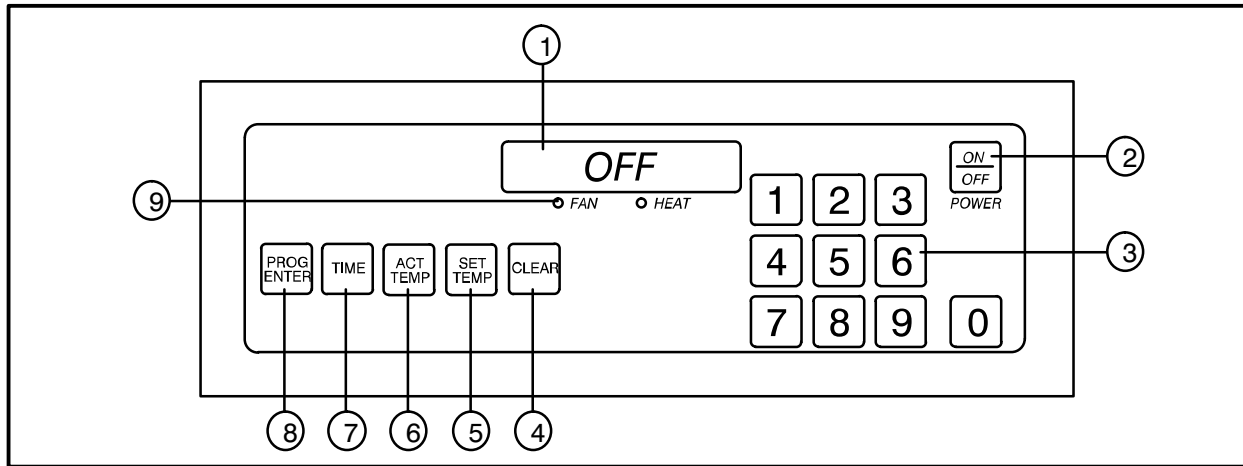

FIGURE 3

**CONTROL DESCRIPTION**

1. DIGITAL DISPLAY – Displays the time, temperature and controller related information.
2. OVEN ON/OFF – Controls power to the oven.
3. NUMERIC KEYS – Used to enter numerical data in the programming mode.
4. CLEAR KEY – Used to clear the display if an error is made in the programming mode.
5. SET TEMP KEY – Used to view or program the temperature setpoint.
6. ACT TEMP KEY – Used to view the current oven temperature.
7. TIME KEY – Used to view or program the cook time.
8. PROG/ENTER KEY – Used to enter and exit the programming mode. Also used to lock in programmed settings.
9. STATUS LAMPS – When lit indicate that the fan or burners are operating.

This oven, supplied with remote control, is equipped with an emergency shut down switch. Should you need to stop the belt, fans, or heat press the emergency switch.

**Do not use the emergency switch as a GENERAL on/off switch!**

**CONTROL OPERATION**

**To turn the oven on:**

1. Press and hold the ON/OFF key (2). The display reads *OFF* when the oven is idle.
2. The display flashes *WAIT • LOW • SET • TIME*.
3. The FAN and HEAT status lamps (9) light. The fans begin to run. The heat rises to the programmed temperature. The conveyor belt travels at the programmed speed.

**To view the cook time setting:**

1. Press the TIME key (7). The LED on the key lights and the display flashes *SET • TIME*.

**To display the actual oven temperature:**

1. Press the ACT TEMP key (6). The LED on the key lights and the display reads *ACTUAL • °F*.

**To view the temperature set point:**

1. Press the SET TEMP key (5). The LED on the key lights and the display flashes *SET • TEMP • °F*.

**To turn the oven off:**

1. Press the ON/OFF key (2). The blower motor(s) continue to run regardless of the controller status until the temperature drops below 180°F (82°C).

## PROGRAMMING PROCEDURES

### Programming the Cook Time:

1. Press the PROGRAM/ENTER key (8).
2. Press the TIME key (7). The display reads *PROG-? • SET • TIME-? • \_ \_ \_ \_*.
3. Use the NUMERIC keys (3) to enter the desired cook time. The display will read the numbers as they are entered. If an error is made, press the CLEAR key (4) and re-enter the number.
4. Press the PROGRAM/ENTER key (8) a second time to lock-in the new time. The new cook time will be stored in the computer's memory.

### Programming the Temperature:

1. Press the PROGRAM/ENTER key (8).
2. Press the SET TEMP key (5). The display reads *PROG-? • SET • TEMP-? • \_ \_ \_ \_ °F*.
3. Use the NUMERIC keys (3) to enter the desired temperature set point. The control displays the numbers as they are entered. If an error is made, press the CLEAR key (4) and re-enter the number.
4. Press the PROGRAM/ENTER key (8) a second time to lock-in the new temperature. The new temperature setpoint will be stored in the computer's memory.

### Operation at the Programmed Settings:

1. Press and hold the ON/OFF key (2).
2. The FAN and HEAT status lamps (9) light. The fans begin to run. The heat rises to the temperature setting stored in the computer's memory. The conveyor belt begins to travel at the timed speed stored in memory.
3. The display will flash *WAIT • LOW • SET • TIME* until the programmed bake temperature is reached. The HEAT lamp (9) will remain lit until the oven reaches the temperature set point.
4. The display reads *READY* and the HEAT lamp (9) goes out.
5. The oven is now ready to accept product.
6. Press and hold the ON/OFF key (2) to turn the oven off. The fans continue to run while the oven cools to a safe temperature.

## DISPLAY INFORMATION

- *WAIT • LOW* – indicates that the present oven temperature is lower than the set point temperature. When the oven reaches the set point temperature the display changes to *READY*.
- *READY* – indicates that the oven is ready to accept product.
- *SET • TEMP • mmss* – indicates the current cook time setting.
- *HIGH • TIME* – indicates that the temperature is well above the set point. This usually occurs when moving from a higher to a lower temperature. Wait until the display reads ready before loading product.
- *HIGH • TEMP • LIMIT* – indicates that the oven temperature exceeds the high limit from the 2nd level program. The Over Temperature Alarm buzzer will sound. Shut the oven off and wait for the unit to cool down.
- *HIGH • TEMP • PANEL* – indicates that the control area reaches an excessive temperature. Shut the oven off and wait for the unit to cool down. Error code generally means loose ground wire.
- *PROBE • OPEN • PROBE • SHORT* – indicates that the temperature sensor has failed. The Alarm buzzer sounds. Shut the oven off and contact a service representative.

# MT3240 Series

---

## SEQUENCE OF OPERATION

*NOTE: The following instructions represent the most common configurations. For questions regarding other options call the Blodgett Service Department at (800)331-5842.*

### MT3240G DOMESTIC AND GENERAL EXPORT – M4193 REV C

#### COMPONENT REFERENCE

*NOTE: Refer to FIGURE 4 page 2–12 for component locations.*

1. COOKING COMPUTER (FW525)
2. BELT STOP RELAY (22672)
3. BLOWER RELAY (22672)
4. HEAT RELAY (22672)
5. DC SPEED CONTROL BOARD (M2379)
6. SPST THERMAL SWITCH (M1362 L140-20F, M2734 L163-30F)
7. HI LIMIT SWITCH (M3295)
8. 115/24 STEP DOWN TRANSFORMER (M2381)
9. COMBUSTION MOTOR (22132)
10. CENTRIFUGAL SWITCH
11. IGNITION MODULE (M1054)
12. PILOT VALVE (LP – 22190, Natural – M5495)
13. BURNER VALVE (LP – 22190, Natural – M5495)
14. MOTOR CONTACTOR (M0708)
15. CONVECTION FANS
16. SPDT THERMAL SWITCH (M3453 L140-20F)
17. COOLING FANS (M2469)
18. RTD PROBE (M7427)
19. 130 VDC MOTOR (M2378)
20. 240/120 STEP DOWN TRANSFORMER (M2352)

#### OPERATION

1. Apply power to the oven. Program the time and temperature into the computer (1). The belt stop relay (2), blower relay (3) and the heat relay (4) energize powering up the oven.
2. When the belt stop relay closes, 120 VAC goes to the DC speed control board (5) and one terminal of a SPST thermal switch (6). If switch is closed, power goes to the manual resettable hi limit switch (7).

*NOTE: The high limit switch is a bulb and capillary style switch. It reacts when the oven cavity temperature exceeds the high limit programmed into the cooking computer.*

*NOTE: The thermal switch is located in the control compartment. This switch opens when the face of the switch sees 140 °F and closes when there is a 10-20 ° drop in temperature across the face of the switch. The switch interrupts the heat circuit.*

If the high limit switch is closed power flows to the primary side of a 115/24 volt step down transformer (8) and the combustion motor (9) of the flame blower. The combustion motor powers up. When the combustion motor reaches full speed, a centrifugal switch (10) closes sending 24 VAC to the ignition module (11). After the module's self diagnostics are complete, the pilot valve (12) opens. A proof of flame allows the burner valve (13) to cycle on and off for every call for heat.

3. The blower relay sends 115 volts to the coil of the motor contactor (14) starting the two convection fans (15) in the rear of the oven. This contactor also supplies power to the N.C. terminal of a SPDT thermal switch (16). The switch toggles if the temperature passing its face exceeds the rating on the back of the switch and may start the fans even if the oven is off. If this switch is cold, it should be made between common and N.C. terminals sending power to the cooling fans (17).

*NOTE: The SPDT thermal switch is located in the junction box in the rear of the oven in the blower compartment.*

4. On a call for heat from the cooking computer as sensed by an RTD probe (18), the heat relay closes sending 24 VAC to the burner valve. This valve opens sending gas to the flame blower for ignition.

*NOTE: The RTD probe is located in the back of the oven in the convection fan compartment. It should be checked with an ohm meter.*

5. The conveyor is driven by an open loop DC control system consisting of a DC speed control board, a 130 VDC motor (19) and the DAC located in the cooking computer. If a time is programmed into the cooking computer, a voltage ranging between .47 and 4.7 is applied to the DC speed control board. The output voltage measured at A1 and A2 of the board to the motor varies from 20 to 130 VDC based on the DAC voltage applied to the board or the time programmed into the computer.

*NOTE: The DAC receives 20 VDC from the speed control boards. The DAC returns a portion of the voltage (between .47 and 4.7 VDC). The amount of voltage is dependent on the time programmed into the computer.*

*NOTE: This type of system does not sense the weight of the product and will slow down slightly if the belt is fully loaded.*

*NOTE: The control voltage is supplied by a 240/120 step down transformer (20). The transformer is located in the control compartment.*

# MT3240 Series

---

## MT3240E DOMESTIC AND GENERAL EXPORT – M4196 REV C

### COMPONENT REFERENCE

*NOTE: Refer to FIGURE 5 page 2–13 for component locations.*

1. COOKING COMPUTER (FW525)
2. BELT STOP RELAY (22672)
3. BLOWER RELAY (22672)
4. MOTOR CONTACTOR (M0708)
5. CONVECTION FANS
6. SPDT THERMAL SWITCH (M2453 140-20F)
7. COOLING FANS (M2469)
8. RTD PROBE (M7427)
9. SPST THERMAL SWITCH (M1362 L140-20F)
10. HIGH LIMIT SWITCH (M3295)
11. HEAT RELAY (22672)
12. MERCURY CONTACTOR
13. DC SPEED CONTROL BOARD (M2379)
14. 130 VDC MOTOR (M2378)

### OPERATION

1. Apply power to the oven. Program the time and temperature into the computer (1). The belt stop relay (2) and blower relay (3) energize powering up the oven.
2. The blower relay sends 115 volts to the coil of the motor contactor (4) starting the two convection fans (5) in the rear of the oven. Power is also applied to the N.C. terminal of a SPDT thermal switch (6). The switch toggles if the temperature passing its face exceeds the rating on the back of the switch and may start the fans even if the oven is off. If this switch is cold, it should be made between common and N.C. terminals sending power to the cooling fans (7).

*NOTE: The SPDT thermal switch is located in the cooking computer control compartment. This switch toggles when the temperature passing its face exceeds the rating on the back of the switch and closes when there is a 10-20° drop in temperature across the face of the switch.*
3. On a call for heat from the cooking computer, as sensed by an RTD probe (8), the heat relay (11) closes sending 115 VAC to one side of a SPST thermal switch (9). If the switch is closed power goes to one terminal of the manual resettable high

limit switch (10). If this switch is closed 115VAC goes to the coil of a mercury contactor (12).

*NOTE: The thermal switch is located in the control compartment. This switch opens when the face of the switch sees 140 °F and closes when there is a 10-20 ° drop in temperature across the face of the switch. The switch interrupts the heat circuit.*

*NOTE: The high limit switch is a bulb and capillary style switch. It reacts when the oven cavity temperature exceeds the high limit programmed into the cooking computer.*

*NOTE: When the coil is energized on the contactor, mercury is displaced completing a circuit within the contactor, sending power to the heating elements.*

*NOTE: The RTD probe is located in the rear of the oven in the convection fan compartment.*

4. The conveyor is driven by an open loop DC control system consisting of a DC speed control board (13), a 130 VDC motor (14) and the DAC located in the cooking computer. If a time is programmed into the cooking computer, a voltage ranging between .47 and 4.7 is applied to the DC speed control board. The output voltage measured at A1 and A2 of the board to the motor varies from 20 to 130 VDC based on the DAC voltage applied to the board or the time programmed into the computer.

*NOTE: The DAC receives 20 VDC from the speed control boards. The DAC returns a portion of the voltage (between .47 and 4.7 VDC). The amount of voltage is dependent on the time programmed into the computer.*

*NOTE: This type of system does not sense the weight of the product and will slow down slightly if the belt is fully loaded.*

*NOTE: The control voltage is supplied by a 240/120 step down transformer. The transformer is located in the control compartment.*

## MT3240G AUSTRALIA — M4174 REV A

### COMPONENT REFERENCE

*NOTE: Refer to FIGURE 6 page 2–14 for component locations.*

1. COOKING COMPUTER
2. BELT STOP RELAY
3. BLOWER RELAY
4. HEAT RELAY
5. DC SPEED CONTROL BOARD
6. SPST THERMAL SWITCH
7. HI LIMIT SWITCH
8. SPST PRESSURE SWITCH
9. COMBUSTION MOTOR
10. STEP DOWN TRANSFORMER
11. IGNITION CONTROL MODULE
12. PILOT VALVE
13. BURNER VALVE
14. RTD PROBE
15. SPDT PRESSURE SWITCH
16. MOTOR CONTACTOR
17. CONVECTION FANS
18. COOLING FANS
19. SPST THERMAL SWITCH
20. 180VDC MOTOR

### OPERATION

1. Apply power to the oven. Program the time and temperature into the computer (1). The belt stop relay (2), blower relay (3) and the heat relay (4) energize powering up the oven.
2. When the belt stop relay closes, 120 VAC goes to the DC speed control board (5) and one terminal of a SPST thermal switch (6). If switch is closed, power goes to the manual resettable hi limit switch (7).

*NOTE: The high limit switch is a bulb and capillary style switch. It reacts when the oven cavity temperature exceeds the high limit programmed into the cooking computer.*

*NOTE: The thermal switch is located in the control compartment. This switch opens when the face of the switch sees 140 °F and closes when there is a 10-20 ° drop in temperature across the face of the switch. The switch interrupts the heat circuit.*

If the high limit switch is closed power flows to one terminal of a SPST pressure switch (8).

*NOTE: This pressure switch senses pressure from the convection fans. If any of the convection fans fail this switch opens cutting power to the combustion motor.*

If the pressure switch is closed, 240 volts is applied to the combustion motor (9) and a 240/24VAC step down transformer (10). When the step down transformer is powered up, 24 volts is applied to terminal #2 of the ignition control module (11). After the module's self diagnostics are complete, the pilot valve (12) opens. A proof of flame allows the burner valve (13) to cycle on and off for every call for heat.

3. On a call for heat from the cooking computer as sensed by an RTD probe (14), the heat relay closes sending 24 VAC to a SPDT pressure switch (15).

*NOTE: This pressure switch senses a vacuum created by the combustion blower. If the blower fails, the switch toggles between de-energizing the main valve and illuminating a red indicator light.*

## MT3240 Series

---

If the switch is closed, 24 volts is applied to the coil of the main burner valve.

4. The blower relay sends 240 volts to the coil of the motor contactor (16) starting the two convection fans (17) in the rear of the oven. This contactor also supplies power to the N.C. terminal of a SPDT thermal switch (19). The switch toggles if the temperature passing its face exceeds the rating on the back of the switch and may start the fans even if the oven is off. If this switch is cold, it should be made between common and N.C. terminals sending power to the cooling fans (18).

*NOTE: The SPDT thermal switch is located in the junction box in the rear of the oven in the blower compartment.*

5. The conveyor is driven by an open loop DC control system consisting of a DC speed control board, a 180 VDC motor (20) and the DAC located in the cooking computer. If a time is programmed into the cooking computer, a voltage ranging between .47 and 4.7 is applied to the DC speed control board. The output voltage measured at A1 and A2 of the board to the motor varies from 20 to 180 VDC based on the DAC voltage applied to the board or the time programmed into the computer.

*NOTE: The DAC receives 20 VDC from the speed control boards. The DAC returns a portion of the voltage (between .47 and 4.7 VDC). The amount of voltage is dependent on the time programmed into the computer.*

*NOTE: This type of system does not sense the weight of the product and will slow down slightly if the belt is fully loaded.*

## MT3240G CE – M4172 REV C

### COMPONENT REFERENCE

*NOTE: Refer to FIGURE 7 page 2–15 for component locations.*

1. COOKING COMPUTER (FW525)
2. BLOWER RELAY (22672)
3. BELT STOP RELAY (22672)
4. HEAT RELAY (22672)
5. MOTOR CONTACTOR (M2247)
6. CONVECTION FANS (Clockwise – , Counter-clockwise – )
7. CONVECTION FAN PRESSURE SWITCH (M0595)
8. DC DRIVE BOARD (M3153)
9. HI LIMIT SWITCH (M3295)
10. DC MOTOR (M3128)
11. SPST THERMAL SWITCH (M1362)
12. SPST RELAY (16775)
13. TPDT RELAY (90250)
14. TEN SECOND TIMER (M3173)
15. DIFFERENTIAL PRESSURE SWITCH (M2819)
16. COMBUSTION BLOWER MOTOR (M2386)
17. LANDIS & GYR IGNITION CONTROL SYSTEM (M3168)
18. 2 SECOND TIMER (M3172)
19. DUAL SOLENOID GAS VALVE (Natural – M6000, LP – M6001)
20. RTD PROBE (M7427)
21. SPDT THERMAL SWITCH (M2453)
22. COOLING FANS (23034)

### OPERATION

1. Apply power to the oven. Program the time and temperature into the computer (1). The blower relay (2), belt stop relay (3) and heat relay (4) pull in and power up three separate circuits. The voltage to the relay coils is 12 VDC.
2. The blower relay closes sending 230 volts to the coil of the motor contactor (5). Points 1, 2, 5 and 6 close powering the convection fans (6 & NO TAG).
3. The convection fan pressure switch (7) closes due to the vacuum that is established in the burner tube chamber by the operation of the convection fans.
4. The belt stop relay sends 230 volts to the DC drive board (8) and the manual reset hi limit switch (9). The DC motor (10) starts provided there is a time entered in the cooking computer.  
*NOTE: The motor used in this oven is 180 volts DC at its highest speed.*  
*NOTE: This relay will only be powered if there is a time programmed into the computer. THE OVEN WILL NOT HEAT IF TIME IS NOT PROGRAMMED INTO THE COMPUTER.*  
*NOTE: The high limit switch is a bulb and capillary style switch. It reacts when the oven cavity temperature exceeds the high limit programmed into the cooking computer.*
5. The heat relay sends 230 volts to a single pole single throw thermal switch (11). If closed the relay continues to send power to one side of a single pole single throw relay (12). This relay will not see power at it's coil until a triple pole double throw relay (13) closes and the ten second timer (14) counts down.
6. Once the convection fan pressure switch closes, 230 volts go to a differential pressure switch (15), the combustion blower motor (16), terminal #7 and the coil of the triple pole double throw relay.
7. When a differential is sensed at the differential pressure switch the switch changes position allowing power to go to terminal #9 of the triple pole double throw relay. This relay is a latching

## MT3240 Series

---

relay and is held closed by power that was applied at terminal #7.

8. Power flows from terminal #8 of the triple pole double throw relay to a ten second purge timer. This timer allows the combustion blower to operate for ten seconds allowing the combustion chamber to clear of any combustible gasses.
9. After the timer times out the voltage is applied to the other side of the coil of the single pole single throw relay. When that set of contacts closes, voltage goes to terminal #1 of the Landis & Gyr ignition control system (17). Terminal #8 will send power to one side of a two second timer (18) and the pilot coil of the dual solenoid gas valve (19). After two seconds elapse, the voltage is applied to the main coil of the dual solenoid gas valve. This voltage will remain provided there is a call for heat from the computer. If proof of flame is strong the ignition system stays powered up. Should the flame signal be lost, the ignition control system will lock out.

*NOTE: Cooking computer receives information from an RTD probe (20) located in front of the combustion blower motor. The information is in the form of resistance. The resistance ascends as temperature increases.*

10. When power is applied to the motor contactor coil voltage is also applied to the NC terminal of a single pole double throw thermal switch (21). This switch in a cold state should be made between NC and common powering up the cooling fan (22) located in the cooking computer compartment.

*NOTE: The single pole double throw switch powers up the cooling fan even if the oven is turned off.*

## MT3240E CE – M6509 REV C

### COMPONENT REFERENCE

*NOTE: Refer to FIGURE 8 page 2–16 for component locations.*

1. COMPUTER (FW525)
2. BELT STOP RELAY (22672)
3. BLOWER RELAY (22672)
4. HEAT RELAY (22672)
5. MOTOR CONTACTOR (M0708)
6. SPDT THERMAL SWITCH (M2453 L140–20F)
7. COOLING FANS (M2469)
8. CONVECTION FANS (Clockwise – , Counter-clockwise – )
9. RTD PROBE (M7427)
10. SPST THERMAL SWITCH (M1362 L140–20F, M2734 L165–30F)
11. MANUAL RESETABLE HIGH LIMIT SWITCH (M3295)
12. HEATING ELEMENT CONTACTOR (R1530)
13. HEATING ELEMENTS (M2573)
14. 130 VDC MOTOR (M2378)
15. #2 HALL EFFECT PICKUP (M0984)
16. DC SPEED CONTROL BOARD (M2379)
17. STEP DOWN TRANSFORMER (M7170)

### OPERATION

1. Apply power to the oven. Program the time and temperature into the computer (1). The belt stop relay (2), blower relay (3) and the heat relay (4) energize powering up the oven.
2. The blower relay closes sending power to the motor contactor (5) and the N.C. terminals a SPDT thermal switch (6). The switch toggles if the temperature passing its face exceeds the rating on the back of the switch and may start the fans even if the oven is off.

*NOTE: The thermal switch is located in the junction box in the convection fan compartment.*

Two cooling fans (7) are located in the rear of the oven. These cooling fans protect the convection fans from high ambient heat. Two additional cooling fans (7) are located in the computer control compartment. These cooling fans protect the controls from high ambient heat.

The motor contactor closes energizing three convection fans (8) in the rear of the oven.

3. On a call for heat from the cooking computer, as sensed by an RTD probe (9), the heat relay closes sending 115 VAC to one terminal of a N.C. SPST thermal switch (10). The switch toggles if the temperature passing its face exceeds the rating on the back of the switch.

*NOTE: The RTD probe is located in the control compartment. It should be checked with an ohm meter. The SPST thermal switch is located in the rear of the convection fan compartment.*

If the switch is closed, 115 VAC is delivered to one terminal of the manual resetable high limit switch (11). The high limit switch is a bulb and capillary style switch. It reacts when the oven cavity temperature exceeds the high limit programmed into the cooking computer.

If the manual resetable high limit switch is closed power is sent to the contact coil of the heating element contactor (12) energizing the heating elements (13).

4. The conveyor belt is driven by a closed loop D.C. drive system consisting of a 130 VDC motor (14), a #2 Hall effect pickup (15), a DC speed control board (16) and the DAC located

## MT3240 Series

---

in the cooking computer. The motor speed varies based on the time programmed into the cooking computer. If time is programmed, a voltage from .3 to 3.8 is applied to the DC speed control board. The output voltage measured at terminals A1 and A2 varies from 20 to 130 VDC based on the DAC voltage applied to the board or the time programmed into the computer.

*NOTE: The DAC receives 20 VDC from the speed control board. The DAC returns a portion of the voltage (between .3 and 3.8 VDC). The amount of voltage is dependent on the time programmed into the computer.*

*NOTE: This type of system does sense the weight of the product and will not slow down if the belt is fully loaded.*

*NOTE: The control voltage is supplied by a 240/120 step down transformer (17). The transformer is located in the control compartment.*

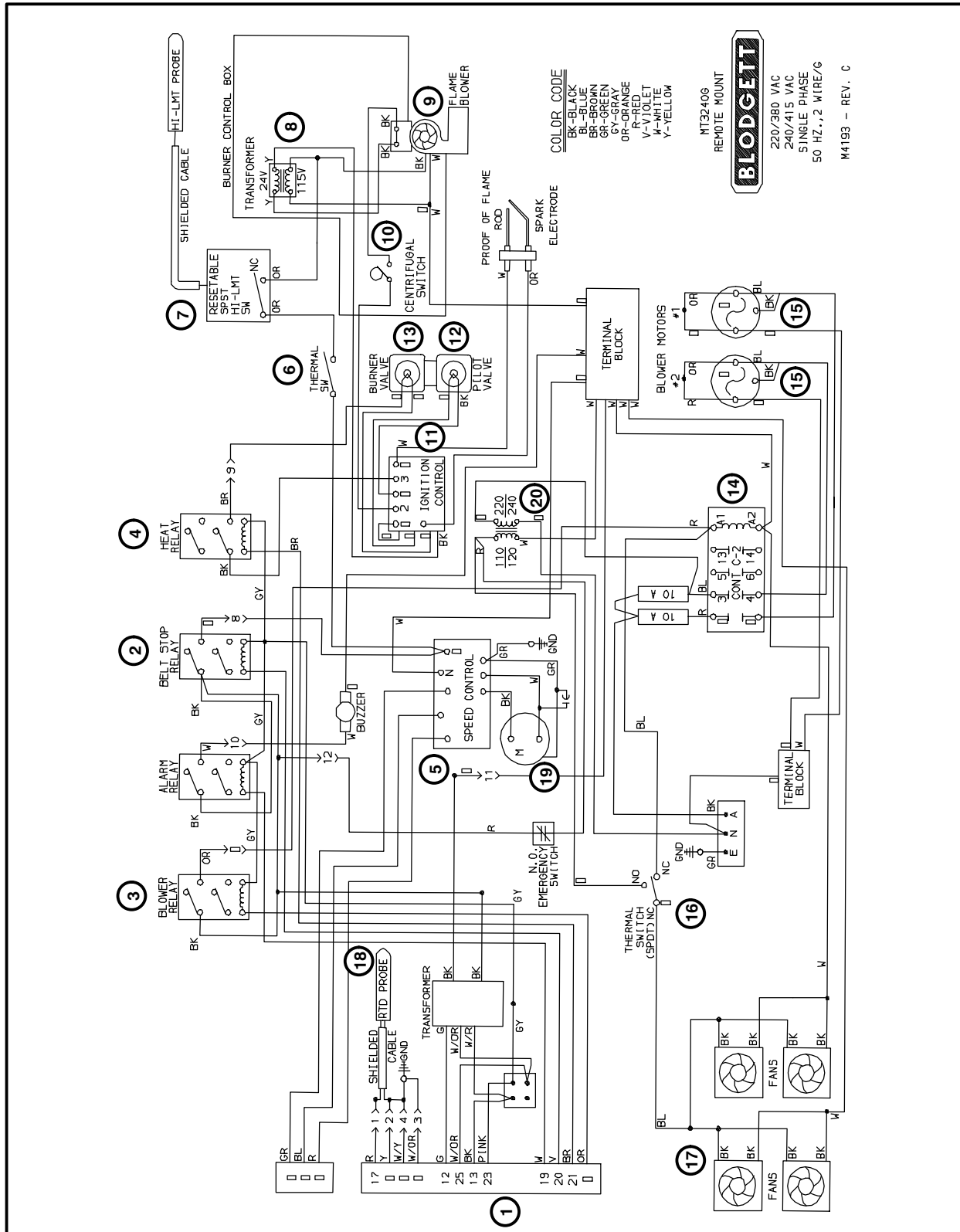

FIGURE 4

# MT3240 Series

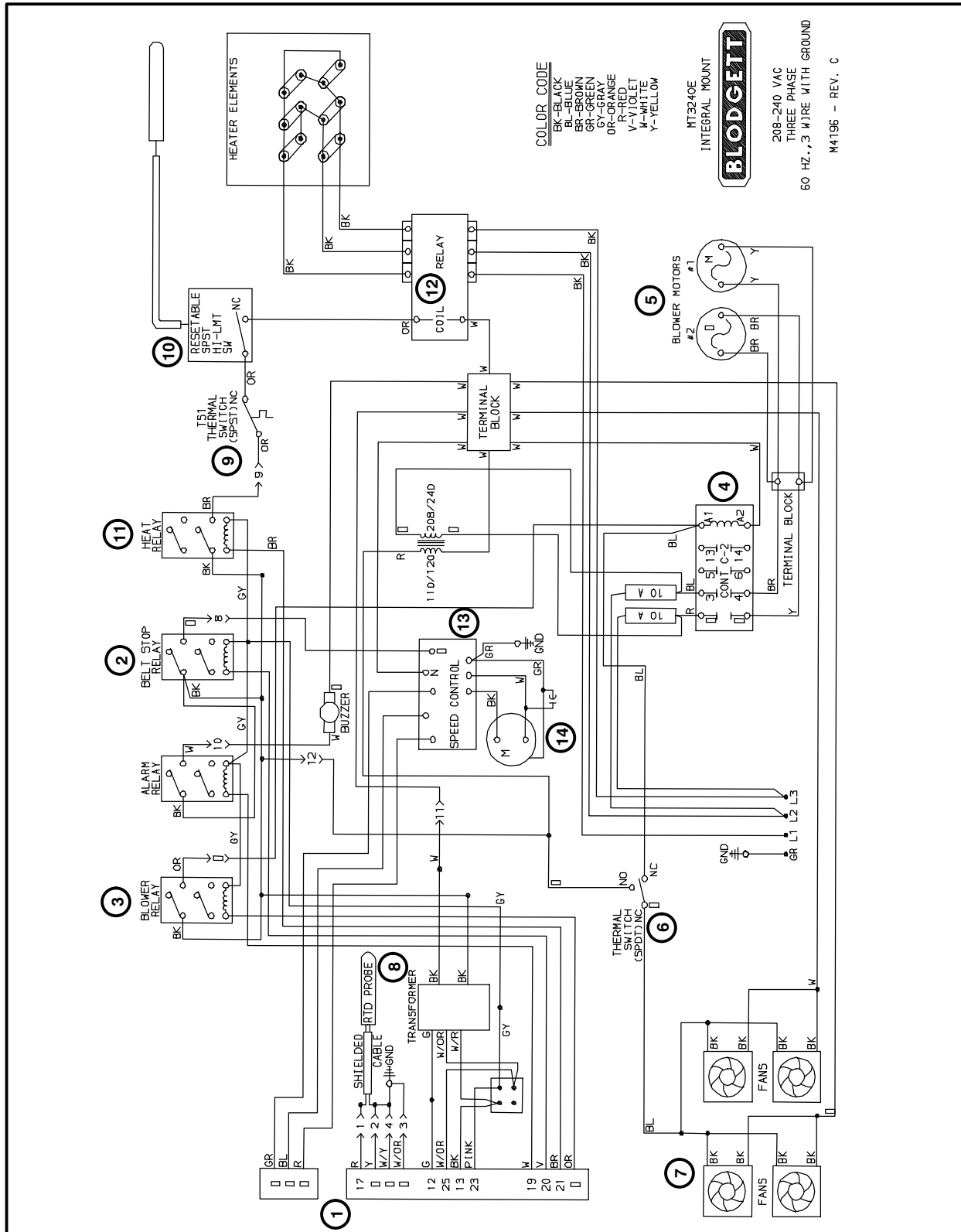

FIGURE 5

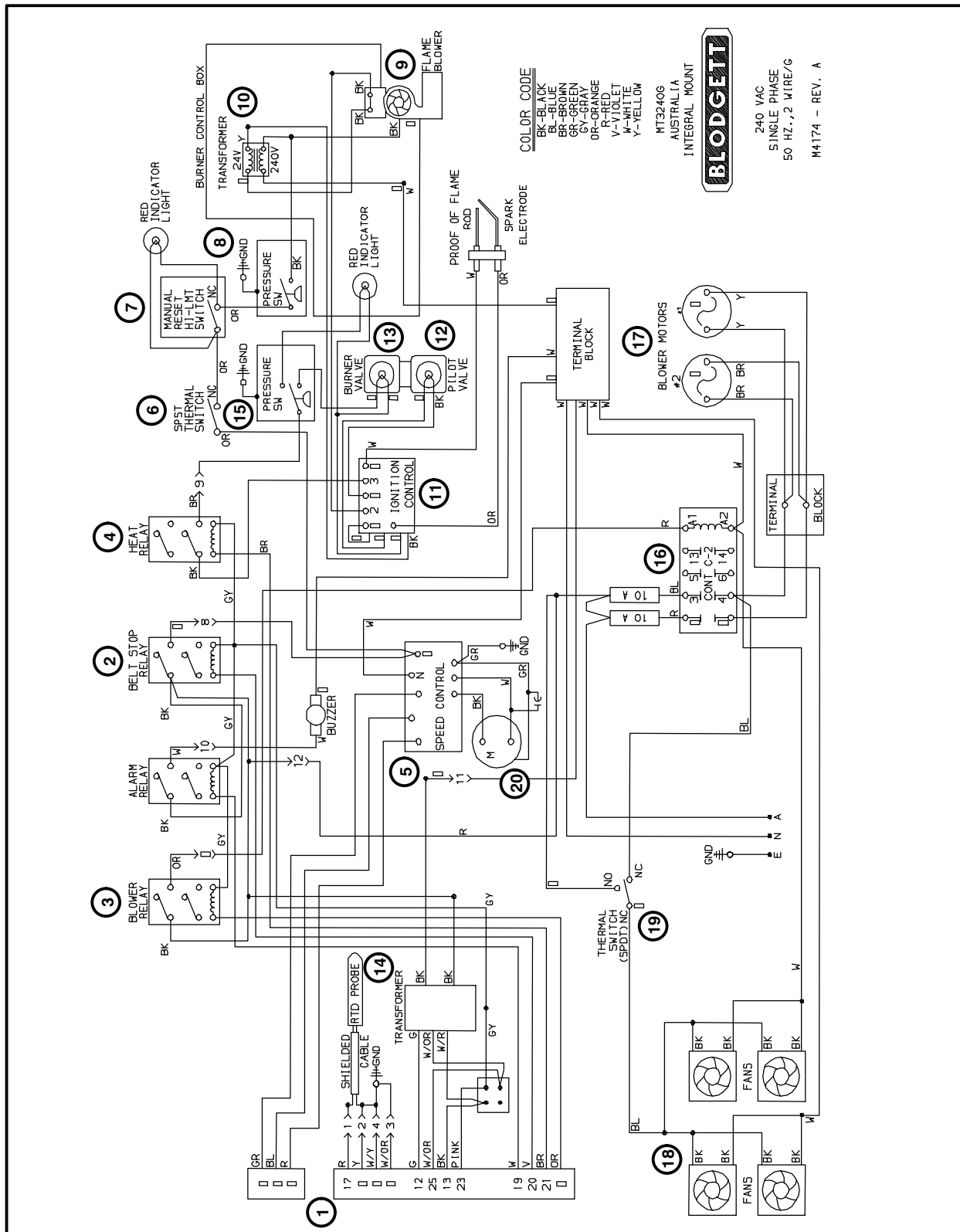

FIGURE 6

# MT3240 Series

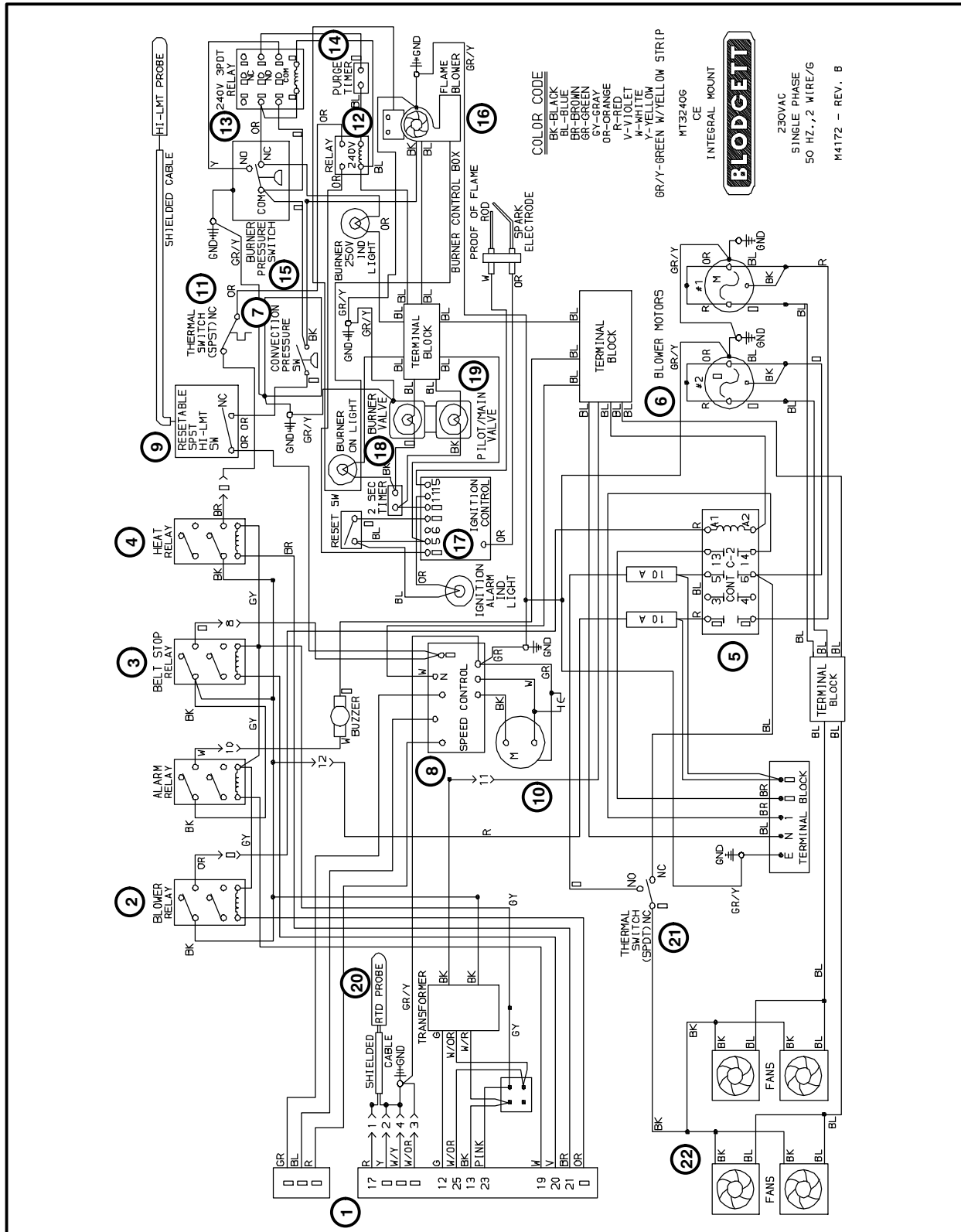

FIGURE 7



### OVEN ADJUSTMENTS FOR COOKING

The combination of belt time, oven temperature, and air flow are important for achieving quality results from your Blodgett conveyor oven. Use the following guidelines to adjust the belt time and oven temperature of your unit. For questions regarding further oven adjustments, please contact your local Blodgett Sales Representative for assistance.

#### CONVEYOR SPEED AND OVEN TEMPERATURE

Conveyor belt speed (cook time) and oven temperature are the two variables used when fine tuning your oven for a specific product. To determine the optimum bake time and temperature, make small changes for each trial and keep one variable constant. For example, if the oven temperature is 460°F (238°C) and the belt speed is 7 minutes, but the pizza is not browned enough, increase the temperature to 475°F (246°C) and keep the belt speed the same. However, if the center of the pizza is not completely cooked, keep the oven temperature the same, and increase the bake time to 7 minutes and 30 seconds. In general, raise the bake temperature to increase browning, and lengthen the belt time to increase doneness.

#### FINISHED PRODUCT TEMPERATURES

Internal temperatures of the cooked products should be measured immediately after the product exits the cooking chamber to ensure a safe food temperature. Internal pizza temperatures should be over 165°F (74°C). Minimum temperature guidelines vary depending on the food items.

#### AIR FLOW ADJUSTMENTS

Slide the product clearance adjustment plates to the lowest possible setting for your menu items. Lowering the clearance plates will reduce the amount of hot air escaping from the chamber openings.

*NOTE: The product clearance adjustment plates can be found on the SG3240 Series ovens only.*

Air flow adjustments may be necessary to fine tune the oven for your particular product. The air plate, located at the top of the baking chamber, contains holes that can be covered using Block-off Plates. The plates can easily be adjusted to regulate the air flow for your particular needs. Use the following guidelines to adjust the Block-off Plates. See NO TAG.

1. Ensure the oven is Off and completely cooled.
  2. Remove the upper end plug from the drive side of the oven.
  3. Using the supplied air plate hook, pull the air plate out of the oven.
  4. Remove the wing nuts, screws, and washers holding the Block-off Plates.
  5. Adjust the plates.
  6. Replace the wing nuts, screws, and washers to tightly secure the Block-off plates in their new locations. Make a sketch of the final air-plate setup for future reference.
- NOTE: One or two block-off plates may be left off entirely if appropriate to obtain the desired results.*
7. Replace the air plate.
  8. Replace the upper end plug.

The following examples illustrate air flow regulation.

*NOTE: The first half of the oven chamber greatly affects the initial baking of the product, while the last half largely affects the browning.*

- A good bake time and temperature have been established, but more top browning is desired. Slide one of the Block-off Plates to uncover a row of holes toward the exit end of the oven.
- The bottom of the pizza is golden brown, but the top is too dark. Close rows at the exit end of the oven to reduce final browning.
- The center of the pizza is still doughy and the toppings are not fully cooked. Open up rows at the chamber entrance and close rows at the chamber exit.

*CHAPTER 3*

---

***CALIBRATION AND  
ADJUSTMENT***

## CONVECTION BLOWER MOTORS

### TO CHECK MOTOR ROTATION

1. Remove the back of the oven body and verify proper motor rotation. (See FIGURE 1)

For motor placement, the direction of rotation is viewed left to right from the oven's rear. Typically the motor direction is referenced to the end of the shaft (EOS). However due to the vertical positioning of the motors in Blodgett Conveyor ovens, it is more instructive to reference the end of the motor (EOM) as looking from the rear of the oven. In FIGURE 1 all directions are taken from EOM. The correct rotation amperage draw is approximately 1 amp. If the measured amperage is less than .5, check for proper motor rotation direction.

### TO CHECK LOW-LIMIT

1. Turn the oven on and let it heat up to approximately 200°F (93°C).
2. Shut the oven off. The blowers should come back on in several seconds.
3. When the blowers shut off, turn the oven on.

If computer controlled press the "ACT TEMP" key to verify that the blowers shut off between 135°F (57°C) and 170°F (77°C). If the blowers do not shut off refer to the Troubleshooting section.

For standard controls, turn the blower switch to on to record the temperature. Adjust the hi/lo board if necessary. See page 3–5 for temperature calibration procedure.

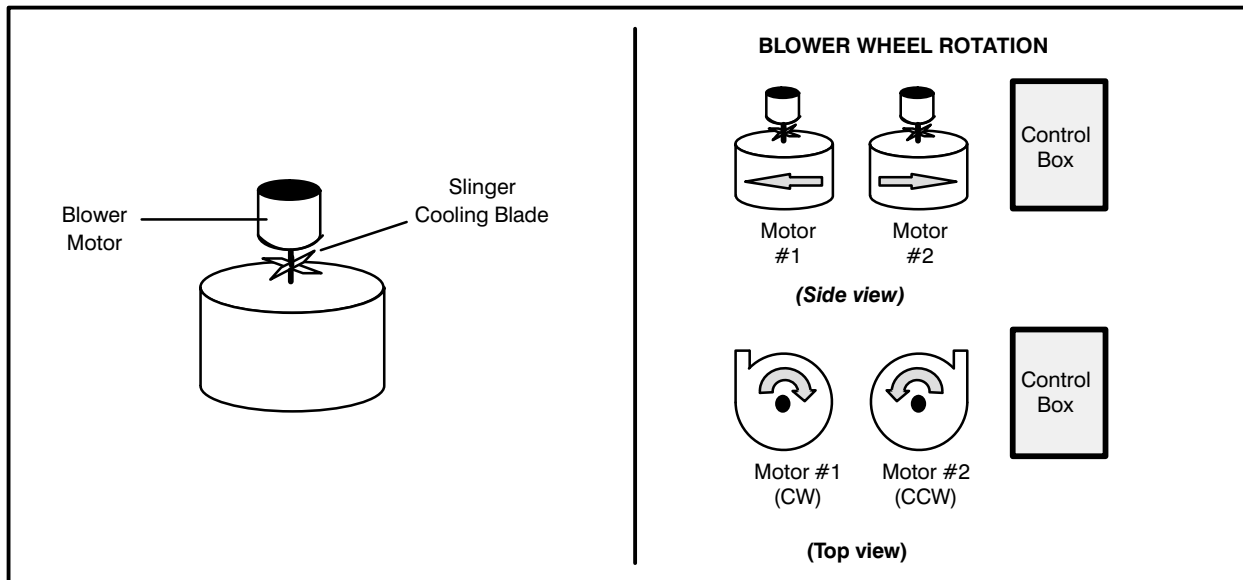

FIGURE 1

## CALIBRATION AND ADJUSTMENT

### REGULATED GAS PRESSURE

1. Let the oven run up to 510°F (266°C). You may now verify the operational and regulated gas pressures.

Incoming static gas pressure to the unit, with all the gas appliances drawing from the supply, should be a minimum of 5.5" W.C. (13.7 mbar) for natural gas and 11" W.C. (28 mbar) for propane gas. The maximum pressure should not exceed 13" W.C. (32 mbar). The manifold pressure, if measured after the regulator located inside the control box, must be 3.5" W.C. (9 mbar) for natural gas and 10" W.C. (25 mbar) for propane gas. For CE pressures reference TABLE 2 on page 1–5 of the Introduction.

Both gas pressures should be measured at the same time with two water manometers. This method will reveal any obstructions in the pipe line or inadequate pipe size.

The pressure can be checked at the tap on the dual regulated gas valve or at the tap on the tee valve. If pressure adjustments are needed, turn the adjusting screw located under a screw cap of the dual regulated valve. Adjust the gas pressure by turning the screw clockwise to raise the gas pressure and counter-clockwise to lower the gas pressure. Be sure to reinstall the screw cap; should the diaphragm rupture this cap acts as a flow limiter.

The air shutter disc on the burner blower motor, located inside the control box at the top of the assembly, is factory adjusted to provide the most efficient blue flame possible at sea level. Visually examine the flame to verify it's quality. Should it need adjustment, increase or decrease the air mixture to attain the best flame quality.

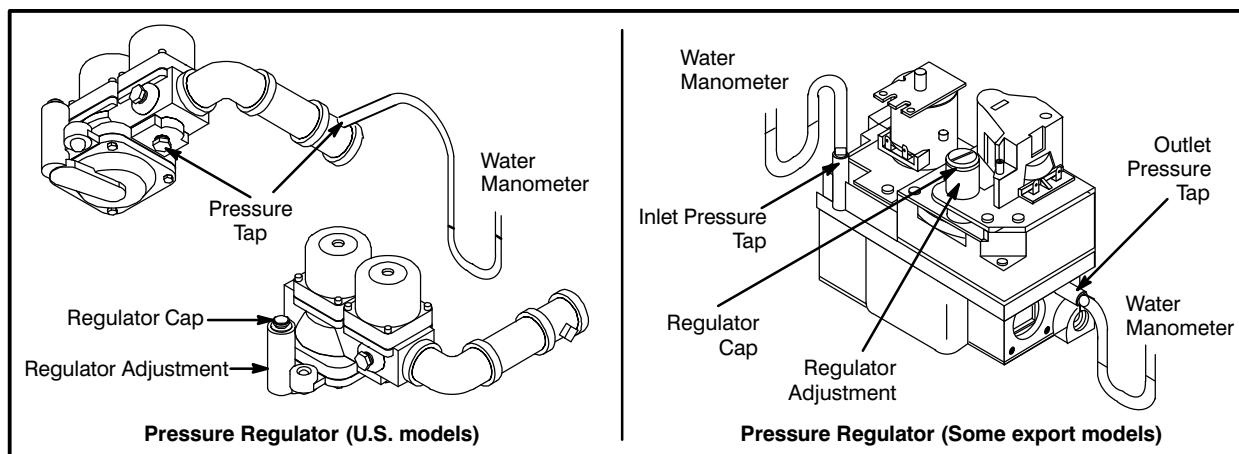

FIGURE 2

### Setting Equipment for Other Types of Gas – CE Models

1. Shut off the gas valve and turn off the operating switch.
2. Dismantle the gas block by means of couplings.
3. Dismantle the main burner and replace the pilot injector.
4. Install the burner and gas block.
5. Check for leakage and possible loose electrical connections.
6. Adjust gas pressure if necessary. See FIGURE 3.

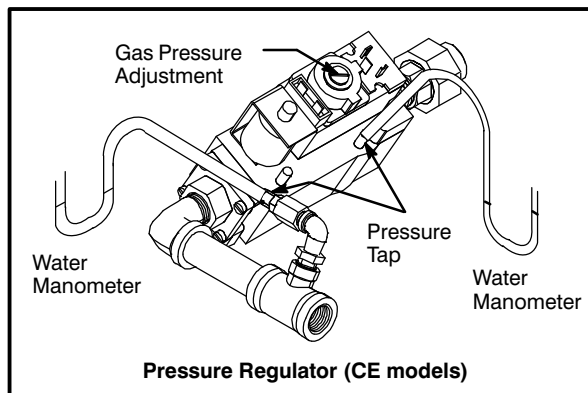

FIGURE 3

**COMPUTER CONTROLLER CONFIGURATION**

**INITIATING ACCESS MODE**

The Cooking Computer provides a special Access Mode for setting and displaying certain computer special functions. To initiate the Access Mode place the control in the OFF state, (OFF is shown in the display when power is first applied to the control). Press the following sequence of keys to set the control to Access Mode: CLEAR 1 2 3 4 5 6 ENTER. The display reads ACCESS.

**CONFIGURATION**

When the controller is in the “ACCESS” mode, press the following buttons: CLEAR 1 1 1 ENTER. With the exception of the positive and negative off-sets, to be addressed later, all display data should correspond to the entries in the chart below. If the data does not match the chart, it should be changed accordingly. When the correct data is displayed press the PROG/ENTER key, the display will cycle on to the next screen. If a step is missed, press the CLEAR button to backup.



















DISPLAY	ACTION TAKEN	DISPLAY	ACTION TAKEN
F/CMODE?	Press 	T $\downarrow$ F° (°C)	Press  again or hit any number and it will change.
POS OFFSET?	Press 	0° (0°)	Press 
NEG OFFSET?	Press 	0° (0°)	Press 
MAX-T ENTRY?	Press 	600° (315°)	Press  or change then press  again.
MAX-T LIMIT?	Press 	625° (330°)	Press 
READY BAND?	Press 	10	Press 
MIN-HT ON?	Press 	60	Press 
DISPLAY INTEG?	Press 	30	Press 
T-CTRL INTEG?	Press 	10	Press 

TABLE 3

NOTE: Press the CLEAR key to back up one parameter.

## CALIBRATION AND ADJUSTMENT

---

### Boost Option – (versions 2.00 or 3.00)

When the controller is in the “ACCESS” mode, press the following buttons: CLEAR 2 1 2 ENTER to enter the boost option.



DISPLAY	ACTION TAKEN	DISPLAY	ACTION TAKEN
BOOST / MODE-? (Flash alternately)	Press 	OPT-1      or OPT-2	Press any numeric key to toggle between OPT-1 and OPT-2
Select OPT-1 to turn off boost mode.			
OPT-1	Press 	DONE SAVE EXIT	Press 

TABLE 4

### EXITING THE ACCESS MODE

After pressing PROG/ENTER the last time, the display will show “EXIT” then beep and return to the “ACCESS” mode. Pressing and holding the ON/OFF key will turn the oven on. A new time and temperature must be entered upon exiting the “ACCESS” mode since the oven will automatically default to 0. The oven will not fire until both time and temperature are entered.

### Firmware Model Version Display

Password: CLEAR 1 2 3 ENTER

**MODEL** - Computer Model Number – 6028  
(Blodgett Conveyor Oven With Speed Control)

**SW-VER** - Firmware version number. V-xyyy xx =  
major version, yy = minor version

**DATE-?** -Firmware release date

**CHKSUM** - ROM checksum stored in PROM. xxxx  
- Value is display in hexadecimal format.

## TEMPERATURE CALIBRATION

### TO ENTER THE CALIBRATION MODE

1. Press the ON/OFF key until *OFF* is displayed.
2. Press CLEAR 1 2 3 4 5 6 ENTER to enter the access mode. The display reads *ACCESS*.
3. Press CLEAR ACT\_TEMP ACT\_TEMP ACT\_TEMP ENTER to access the Temperature Calibration mode.
4. Disconnect the white wire from the D.C. motor. Secure so the wire will not ground against any part of the oven. This will disable the conveyor.

*NOTE: Disregard the controller display. The only numbers of concern are the pyrometer reading and the temperature set point.*

### TO CALIBRATE THE OVEN TEMPERATURE

During operation, the temperature control is based on the measured temperature and the temperature offset which is programmed into the control. If the temperature measured in the center of the oven is below the oven setpoint a positive offset is needed. If the temperature measured in the center of the oven is above the oven setpoint a negative offset is needed.

*NOTE: In the calibration mode the display gives the current measured temperature only.*

#### To view the current temperature setpoint:

1. Press the SET\_TEMP, key.

#### To change the temperature setpoint :

1. Press PROG/ENTER SET\_TEMP.
2. Enter the desired setpoint.
3. Press the PROG/ENTER key.

#### To program the temperature offset:

To change the temperature calibration an offset, positive or negative, must be programmed.

1. Press PROG/ENTER followed by ACT\_TEMP. The display flashes either *POS \* OFFSET* or *NEG \* OFFSET*

*NOTE: POS OFFSET is displayed if a value has been programmed in for a positive offset. NEG OFFSET is displayed if a value has been programmed for a negative offset. The only time both will be displayed is if a value of 0 has been entered for both.*

2. Enter a value for the desired offset. The display flashes *DISPLAY \* INTEG?*.
3. Press the PROG/ENTER key. The default value of 30 will be displayed.
4. Press the PROG/ENTER key. The display will flash *T-CTRL \* INTEG?*.
5. Press the PROG/ENTER key. The default value of 10 will be displayed.
6. Press the PROG/ENTER key.

The control will now resume using the new parameters.

Verify the temperature calibration once the unit has cycled for 5 minutes with the new settings. Repeat calibration using a new offset value if necessary.

### TO EXIT THE CALIBRATION MODE

1. Press the CLEAR key twice.
2. The display flashes *REBOOT* then displays the set time and temperature. You must re-enter a temperature for the oven to start heating again.
  - A.) Press PROG/ENTER SET\_TEMP
  - B.) Enter the desired temperature.
  - C.) Press the PROG/ENTER key. The heat light turns on and the burner begins to cycle at set point.

## BELT SPEED CALIBRATION

### CLOSED LOOP SYSTEM

#### To enter the calibration mode:

1. Press the ON/OFF key until *OFF* is displayed.
2. Press CLEAR 1 2 3 4 5 6 ENTER to enter the Access mode. The display reads *ACCESS*.
3. Press CLEAR TIME TIME TIME ENTER to access the Belt Speed Calibration mode. The display flashes *INIT*.

#### Belt speed calibration:

1. OVEN LENGTH – Set the length of the conveyor belt to 40.
2. MOTOR RATIO – Set the motor gear ratio to 600.
3. SHAFT TEETH – Set the shaft teeth number to 15
4. MOTOR TEETH – Set the motor teeth number to 12.
5. BELT RADIUS – Set the belt radius to 8,893.

*NOTE: The values given are estimates. If you reenter the calibration mode after setting the belt speed, the belt radius may differ from the table.*

6. The display gives a four digit value followed by the letter K. Press ENTER twice to verify the belt time.

#### Belt speed verification:

1. ENTER TEST TIME – Enter a test time to verify the belt speed. The default setting is 7 minutes.
2. WAIT – 1 second delay before the belt moves.
3. ENTER ACTUAL TIME – Place an object on the belt. Note the time from entrance to exit. Enter the actual measured time.
4. ENTER TEST TIME – If the actual measured time is not within 5 seconds of the test time, re-

peat the belt verification test to obtain better accuracy. If the actual measured time is acceptable, press the CLEAR key to continue the belt speed calibration.

5. MAX/MIN CALC TIME – The control sets the fastest and slowest cook time the user can program. This requires a 1 minute delay in the calibration process.

*NOTE: If the control cannot read the shaft encoder the display reads ERROR then ABORT before exiting belt calibration. Verify the connection of the encoder Restart the belt speed calibration.*

6. The display flashes *MIN SET TIME?* Press the PROG/ENTER key to display the calculated minimum set time. Press the PROG/ENTER key to accept this value or enter a new time with a value higher than the default. Press PROG/ENTER again to accept.
7. The display flashes *MAX SET TIME?* Press the PROG/ENTER key to display the calculated maximum set time. Press the PROG/ENTER key to accept this value or enter a new time with a value lower than the default. Press PROG/ENTER again to accept.
8. The display reads *DONE*.

#### To save the new belt speed:

1. Press ENTER to save the belt speed calibration program in the control's memory.

*NOTE: During these adjustments, pressing the clear button will abort all entries and require reprogramming of belt time mode. When exiting the Belt Speed Calibration Mode, enter a time. Otherwise the time defaults to zero, the oven will not heat, and the belt will not move.*

# MT3240 Series

---

## OPEN LOOP SYSTEM – SINGLE BELT

### To enter the calibration mode:

1. Press the ON/OFF key until *OFF* is displayed.
2. Press CLEAR 1 2 3 4 5 6 ENTER to enter the Access mode. The display reads *ACCESS*.
3. Press CLEAR TIME TIME TIME ENTER to access the Belt Speed Calibration mode. The display flashes *INIT*.

### Belt speed calibration:

1. The display reads *BELT SIZE-?*. Enter 40 for the length of the conveyor belt. Press the PROG/ENTER key.
2. The display reads *STEP-1*. The controller is in Step 1 of the calibration procedure: maximum belt speed. The motor control is automatically set to its maximum output. Place an object on the belt and note the time from entrance to exit.

*NOTE: Be certain to measure either the leading edge in and out or the trailing edge in and out. Do not use the leading edge in and the trailing edge out.*

- A.) The display reads *STEP-1TIME-?*. Enter the time measured in STEP-1. Min: 0 Max: 59:59 (min:sec). Press the PROG/ENTER key.
  - B.) The display reads *STEP-1DIST-?*. Enter 36 for the belt length. Press the PROG/ENTER key.
3. The display reads *STEP-2*. The controller is in Step 2 of the calibration procedure: minimum belt speed. The motor control is automatically set to its minimum output.

The belt will travel very slowly during this part of the calibration procedure. To minimize the time spent on STEP-2, measure off 10" on the conveyor support. Place an object on the belt and note the travel time for the 10" measured distance.

- A.) The display reads *STEP-2 TIME-?*. Enter the measured travel time for STEP-2. Min: 0 Max: 59:59 (min:sec). Press the PROG/ENTER key.
  - B.) The display reads *STEP-2 DIST-?*. Enter 10". Press the PROG/ENTER key.
4. The display reads *MIN-TM ENTRY?* (the fastest belt speed). Limits of this value are determined by the Step-1 and Step-2 calibration values. Use 300 (3 min). Press the PROG/ENTER key.
  5. The display reads *MAX-TM ENTRY?* (slowest belt speed). Limits of this value are determined by the Step 1 and Step 2 calibration values. Use 1600 (16 min). Press the PROG/ENTER key.
  6. The display flashes *DONE* and *SAVE*. Press the PROG/ENTER key to permanently store the calibration values in non-volatile memory (NOVRAM).

*NOTE: During these adjustments, pressing the clear button will abort all entries and require reprogramming of belt time mode. When exiting the Belt Speed Calibration Mode, enter a time. Otherwise the time defaults to zero, the oven will not heat, and the belt will not move.*

---

## CALIBRATION AND ADJUSTMENT

---

### OPEN LOOP SYSTEM – TWIN BELT

#### To enter the calibration mode:

1. Press the ON/OFF key until *OFF* is displayed.
2. Press CLEAR 1 2 3 4 5 6 PROG/ENTER. The display flashes *ACCESS*.
3. Press CLEAR, FRONT BELT, FRONT BELT, FRONT BELT, PROG/ENTER to enter the Access mode. The display reads *FRONT*.
4. Press FRONT BELT to toggle between front and rear belt.
5. The display reads *FRONT–INIT–F*.

#### Belt speed calibration:

1. The display reads *BELT SIZE–?*. Enter 40 for the length of the conveyor belt. Press the PROG/ENTER key.
2. The display reads *STEP–1*. The controller is in Step 1 of the calibration procedure: maximum belt speed. The motor control is automatically set to its maximum output. Place an object on the belt and note the time from entrance to exit.

*NOTE: Be certain to measure either the leading edge in and out or the trailing edge in and out. Do not use the leading edge in and the trailing edge out.*

- A.) The display reads *STEP–1TIME–?*. Enter the time measured in STEP–1. Min: 0 Max: 59:59 (min:sec). Press the PROG/ENTER key.
- B.) The display reads *STEP–1DIST–?*. Enter 36 for the belt length. Press the PROG/ENTER key.

3. The display reads *STEP–2*. The controller is in Step 2 of the calibration procedure: minimum belt speed. The motor control is automatically set to its minimum output.

The belt will travel very slowly during this part of the calibration procedure. To minimize the time spent on STEP–2, measure off 10” on the conveyor support. Place an object on the belt and note the travel time for the 10” measured distance.

- A.) The display reads *STEP–2 TIME–?*. Enter the measured travel time for STEP–2. Min: 0 Max: 59:59 (min:sec). Press the PROG/ENTER key.
  - B.) The display reads *STEP–2 DIST–?*. Enter 10”. Press the PROG/ENTER key.
4. The display reads *MIN–TM ENTRY?* (the fastest belt speed). Limits of this value are determined by the Step–1 and Step–2 calibration values. Use 300 (3 min). Press the PROG/ENTER key.
  5. The display reads *MAX–TM ENTRY?* (slowest belt speed). Limits of this value are determined by the Step 1 and Step 2 calibration values. Use 1600 (16 min). Press the PROG/ENTER key.
  6. The display flashes *DONE* and *SAVE*.

*NOTE: During these adjustments, pressing the clear button will abort all entries and require reprogramming of belt time mode. When exiting the Belt Speed Calibration Mode, enter a time. Otherwise the time defaults to zero and the oven will not heat, and the belt will not move.*

### RERATING THE APPLIANCE

Due to the lack of oxygen at higher elevations, the unit may need to be rerated. (The orifice size may need to be adjusted to accommodate different air pressures at higher elevations.) If not rerated, incomplete combustion may occur releasing Aldehydes and CO or Carbon Monoxide. **Any of these are unacceptable and may be hazardous to the health of the operator.**

To choose the correct orifice for different altitudes several factors must be known:

1. Altitude
2. BTUs per burner
3. Manifold pressure
4. Correct orifice size at sea level
5. BTU value of the gas

The following are generally accepted heating values:

- A.) Natural Gas – 1000 BTU/Cu Ft
- B.) Propane – 2550 BTU/Cu Ft
- C.) Butane – 3000 BTU/Cu Ft

6. Specific gravity

The following are generally accepted values (Air = 1.0):

- A.) Natural Gas – 0.63
- B.) Propane – 1.50
- C.) Butane – 2.00

*NOTE: For other gases contact your local gas supplier for values.*

Use the following formulas to calculate the correct orifice:

1. 
$$\frac{\text{Firing rate}}{\# \text{ of burners}} = \text{BTU per burner}$$
2. 
$$\frac{\text{BTU per burner}}{\text{Heating value of Gas}} = \text{CuFt/hr}$$
3. 
$$\frac{\text{CuFt/Hr}}{\text{Specific Gravity Multiplier}} = \text{Equiv. CuFt/hr}$$
4. Use TABLE F-1 from the National Fuel Gas Code Handbook to determine the proper orifice size at sea level.  
*NOTE: The sea level orifice size is needed to determine the proper orifice at any elevation.*
5. Use TABLE F-4 from the National Fuel Gas Code Handbook to determine the correct orifice for the applicable elevation.
6. Use TABLE F-3 from the National Fuel Gas Code Handbook to determine the specific gravity multiplier.

#### EXAMPLE

Known factors:

1. Altitude = 5000 ft.
2. BTUs per appliance = 55,000
3. Number of burners = 2
4. BTU value of the gas = 900
5. Specific gravity = .50

Calculations:

1. 
$$\frac{55,000}{2} = 27,500 \text{ BTU per burner}$$
2. 
$$\frac{27,500}{900} = 30.55 \text{ CuFt/hr}$$
3. 
$$\frac{30.55}{1.10} = 27.77 \text{ Equiv. CuFt/hr}$$

Using the tables in the National Fuel Gas Code Handbook we can determine that:

1. Correct orifice size at sea level = #40
2. Correct orifice size at 5000 ft = #42

## CHECKING THE FIRING RATE

### Method #1

1. Turn off all other appliances on the line. Turn on the appliance to be measured.
2. Using either the 1/2 cu. ft. or the 2 cu. ft. dials located on the gas meter, note the time it takes the indicator to complete one revolution. See FIGURE 4.
3. Use the following formula to determine the firing rate of the meter.

$$\frac{3600 \times \text{size of test dial} \times 1000}{\# \text{ of seconds per revolution}} = \text{BTU/burner}$$

### Example:

A.)  $3600 \times 2 = 7200$

B.)  $\frac{7200}{60} = 120 \text{ Cu. Ft./Hr}$

- C.) To convert to BTU/Hr, multiply by one of the following generally accepted heating values:

Natural Gas –  $1000 \times 120 = 120,000 \text{ BTU}$

Propane –  $2550 \times 120 = 306,000 \text{ BTU}$

Butane –  $3000 \times 120 = 360,000 \text{ BTU}$

*NOTE: You may also use TABLE XII from the National Fuel Gas Code Handbook to aid in determining the firing rate of the appliance. This table eliminates the use of the formulas above. Refer to NO TAG in the Technical Appendix of this manual.*

Locate the time observed in STEP 2. Move across the table to either the 1/2 cu. ft. or the 2 cu. ft. column to find the gas input to the burner.

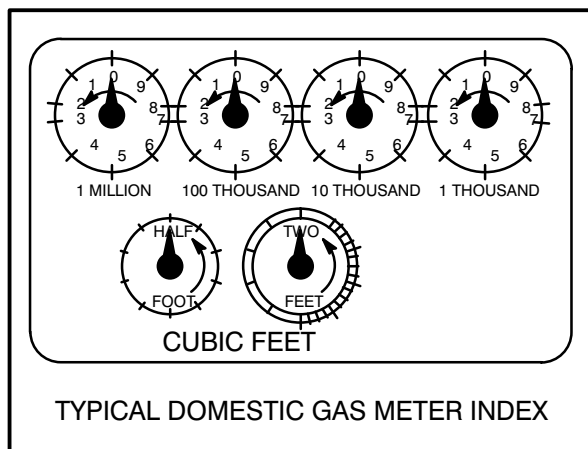

FIGURE 4

### Method #2

You may also determine the firing rate by sizing the main burner orifice and measuring manifold gas pressure. Either way is accurate, however method #1 is faster.

*This page intentionally left blank.*

*CHAPTER 4*

---

***TROUBLESHOOTING***

# MT3240 Series

## DC DRIVE SYSTEM

POSSIBLE CAUSE(S)	SUGGESTED REMEDY
<b>Symptom #1 – Conveyor Belt will not run</b>	
<ul style="list-style-type: none"> <li>• Oven in OFF mode.</li> <li>• Loose computer controller cord connection.</li> <li>• Time not programmed into computer.</li>   <li>• Emergency stop switch on OFF.</li> <li>• Control circuit breaker tripped.</li> <li>• Belt hooked on something in oven.</li> <li>• 5 amp line fuse blown.</li> <li>• 200 milliamp armature fuse blown.</li> <li>• Hall Effect Pickup not connected. (<i>Closed loop systems only</i>) Display reads <i>MOTOR</i>.</li>   <li>• Motor brushes worn out.</li> <li>• Defective conveyor drive motor.</li> <li>• Defective conveyor drive motor controller.</li> <li>• Wire from pickup open or misplaced.</li> </ul>	<ul style="list-style-type: none"> <li>• Turn to ON position.</li> <li>• Adjust and retighten cables and set screws.</li> <li>• Program in a cook time. See Operation Section (page 2–2).</li> <li>• Pull switch out to ON.</li> <li>• Reset breaker.</li> <li>• Turn oven OFF, unhook and repair problem.</li> <li>• Replace fuse. Determine amp draw.</li> <li>• Replace fuse. Determine amp draw.</li> <li>• Verify the unit is set for a single pulse pickup. If not, reset for a single pulse pickup. If yes reattach the pickup. Note #2 on magnet = 1 pulse per rev. #10 on magnet = 5 pulse per rev.</li> <li>• Replace brushes.</li> <li>• Replace conveyor drive motor.</li> <li>• Replace conveyor drive motor controller.</li> <li>• Repair or replace wire.</li> </ul>
<b>Symptom #2 – Computer error code MOTOR - SPEED - ERROR</b>	
<ul style="list-style-type: none"> <li>• Belt speed needs calibration.</li> </ul>	<ul style="list-style-type: none"> <li>• See Calibration and Adjustments (page 3–7).</li> </ul>
<ul style="list-style-type: none"> <li>• Voltage from Bodine controller to DAC not present. The DAC (Digital Analog Control) is a non-repairable component of the computer. There should be approximately 20 VDC between the red and green wires on the 3 pin connection of the DC drive board.</li> </ul>	<ul style="list-style-type: none"> <li>• Replace the drive motor controller.</li> </ul>
<ul style="list-style-type: none"> <li>• DAC voltage is present but not regulated between 4.7 and .47 VDC (open loop) or 3.5 and .38 (closed loop) when different times are programmed into the cooking computer. Measure the voltage between the green and blue wires of the 3 pin connection.</li> </ul>	<ul style="list-style-type: none"> <li>• Replace the computer.</li> </ul>

**COMPUTER CONTROL SYSTEM**

POSSIBLE CAUSE(S)	SUGGESTED REMEDY
<b><i>Symptom #1 – Computer controller displays: PROBE - OPEN - PROBE - SHORT and alarm buzzer sounds</i></b>	
<ul style="list-style-type: none"> <li>• Internal problem with computer controller.</li> <li>• Loose connections at computer controller.</li> <li>• Shorted or open RTD probe.</li> </ul>	<ul style="list-style-type: none"> <li>• Verify display integ. in the 2nd level programming. If the controller has been programmed the computer may need to be replaced.</li> <li>• Tighten connections.</li> <li>• Use the chart in the Technical Appendix (page NO TAG) to determine if probe is bad. Replace if necessary.</li> </ul>
<b><i>Symptom #2 – Computer controller displays: ERROR - HIGH - TEMP - LIMIT</i></b>	
<ul style="list-style-type: none"> <li>• Actual temperature exceeds programmed limit value. Default 605°F (319°C).</li> <li>• Internal problem with computer controller.</li> </ul>	<ul style="list-style-type: none"> <li>• Faulty burner valve relay. Replace relay.</li> <li>• Verify display integ. in the 2nd level programming. If the controller has been programmed the computer may need to be replaced.</li> </ul>

# MT3240 Series

## HEATING SYSTEM

POSSIBLE CAUSE(S)	SUGGESTED REMEDY
<b>Symptom #1 – Burner will not fire</b>	
<ul style="list-style-type: none"> <li>• Oven in OFF mode.</li> <li>• Emergency stop switch on OFF.</li> <li>• Control circuit breaker tripped.</li> <li>• Combustion motor not running.</li>   <li>• Main Temperature Controller not set above ambient temperature.</li> <li>• Manual gas valve closed.</li> <li>• Intermittent Ignition Device (IID) system locked out.</li> <li>• Air pressure switch may be open.</li>   <li>• Blower motor(s) not running.</li>   <li>• High Limit control tripped.</li>   <li>• Thermal switch in control compartment tripped.</li> <li>• Excessive intake air temperature.</li> <li>• If pilot fails to go out when the unit is shut down, the solenoid valve is bad. Unit will not refire if pilot fails to go out when unit is off.</li> </ul>	<ul style="list-style-type: none"> <li>• Turn to ON position.</li> <li>• Pull switch out to ON.</li> <li>• Reset breaker.</li> <li>• Check transformer in combustion burner box for primary and secondary voltage.</li> <li>• Check main control and burner valve relays to see if closed.</li> <li>• Check relay in combustion burner box. If bad replace relay.</li> <li>• Set to desired temperature.</li>   <li>• Open valve.</li> <li>• Reference Technical Appendix (page NO TAG through NO TAG).</li> <li>• Check convection blower (or convection fans) for proper operation. Verify that tube is clear.</li> <li>• Verify voltage to motor. If voltage is present, replace the motor or start capacitor.</li> <li>• Verify that 625°F (330°C) high limit is programmed into the controller. If so reset the high limit. Set the computer to 500°F (260°C). Use a pyrometer to verify the oven temperature. If the oven climbs significantly above the setpoint, use the chart in the Technical Appendix (page NO TAG) to check the probe. If the probe is alright the computer may need replacement.</li> <li>• Verify cooling fan operation and hood system.</li> <li>• Check hood system.</li> <li>• Replace valve.</li> </ul>

## TROUBLESHOOTING

POSSIBLE CAUSE(S)	SUGGESTED REMEDY
<b>Symptom #2 – Oven will not reach desired temperature</b>	
<ul style="list-style-type: none"> <li>• Gas pressure to oven is too low.</li> <li>• Top air plates missing.</li> <li>• Faulty RTD probe.</li>   <li>• Blower motor(s) running backward.</li>   <li>• Controller out of calibration.</li>   <li>• Excessive food/debris accumulation blocking the airflow.</li> </ul>	<ul style="list-style-type: none"> <li>• Verify pressure.</li> <li>• Install air plates.</li> <li>• Use the chart in the Technical Appendix (page NO TAG) to determine if probe is bad. Replace if necessary.</li> <li>• Verify voltage to motor. If voltage is present, replace the motor or start capacitor.</li> <li>• Recalibrate the controller. See Technical Appendix (page 3–5).</li> <li>• The inside of the oven should be cleaned to remove any materials that could have dropped off the conveyor belt and possibly blocked some of the air flow holes. This would include the removal of the conveyor belt, conveyor belt supports, and the nozzles. The oven interior and all parts removed should then be cleaned with an appropriate oven cleaner safe for aluminum.</li> </ul>
<b>Symptom #3 – Burner operates sporadically</b>	
<ul style="list-style-type: none"> <li>• Air pressure switch may be open.</li>   <li>• Thermal switch tripped.</li>   <li>• Faulty RTD probe.</li>   <li>• Excessive food/debris accumulation blocking the airflow.</li> </ul>	<ul style="list-style-type: none"> <li>• Check convection blower (or 4 convection fans) for proper operation. Check pressure switch tube for obstructions.</li> <li>• Determine the ambient temperature in the control compartment. If above 140°F (60°C) check the cooling fan operation.</li> <li>• Use the chart in the Technical Appendix (page NO TAG) to determine if probe is bad. Replace if necessary.</li> <li>• The inside of the oven should be cleaned to remove any materials that could have dropped off the conveyor belt and possibly blocked some of the air flow holes. This would include the removal of the conveyor belt, conveyor belt supports, and the nozzles. The oven interior and all parts removed should then be cleaned with an appropriate oven cleaner safe for aluminum.</li> </ul>

**CONVECTION SYSTEM**

POSSIBLE CAUSE(S)	SUGGESTED REMEDY
<b>Symptom #1 – Blower motor(s) not running</b>	
<ul style="list-style-type: none"> <li>• Oven in OFF mode.</li> <li>• Emergency stop switch on OFF.</li> <li>• No power to oven.</li>   <li>• Motor circuit breaker tripped.</li> <li>• Faulty start capacitor.</li> <li>• Motor(s) burnt out.</li> <li>• Motor contactor open.</li>   <li>• Thermal overload tripped.</li> </ul>	<ul style="list-style-type: none"> <li>• Press ON/OFF key.</li> <li>• Pull switch out to ON.</li> <li>• Verify power to motor(s). If there is voltage present, replace the motor. If voltage is not present, check the motor contactor.</li> <li>• Reset circuit breaker. Determine amp draw.</li> <li>• Replace capacitor.</li> <li>• Check draw (3amps or greater).</li> <li>• Check that the computer is turned on and that a cook time and temperature have been programmed. Check for voltage to the coil of the motor contactor. If voltage is present, replace the contactor. If voltage is not present, check that the blower relay is closed. If not, check for voltage at the blower relay coil. If a 12 VDC voltage is present at the coil the blower relay is bad. If there is no voltage present at the coil the computer may need to be replaced.</li> <li>• Determine if the cooling blower (or fans) are operating. If not, verify voltage to the cooling blower. If voltage is present, replace the cooling blower motor. If voltage is not present, verify voltage through the thermal switch. If no voltage is present, replace the thermal switch.</li> </ul>
<b>Symptom #2 – Blower motor(s) do not shut off</b>	
<ul style="list-style-type: none"> <li>• Faulty motor contactor.</li> <li>• Faulty blower motor relay.</li>   <li>• Faulty auxiliary contact (mounted to motor contactor).</li> <li>• Faulty probe.</li>   <li>• Faulty computer.</li> </ul>	<ul style="list-style-type: none"> <li>• Replace contactor.</li> <li>• If the temperature probe is good check for voltage at the coil of the blower relay. If voltage is not present the relay is bad. Replace the blower relay.</li> <li>• Replace auxiliary contactor.</li> <li>• Check the resistance values of the temperature probe for values from 135-170°F (57-77°C). Reference NO TAG on page NO TAG of the Technical Appendix. If the values do not agree with the chart change the probe.</li> <li>• If voltage is present at the blower relay, the computer is bad. Replace the computer.</li> </ul>

## TROUBLESHOOTING

POSSIBLE CAUSE(S)	SUGGESTED REMEDY
<b>Symptom #3 – Hood system does not operate when oven is on (if interlock is used)</b>	
<ul style="list-style-type: none"><li>• Fan exhaust/supply problem.</li><li>• Defective interlock circuit.</li></ul>	<ul style="list-style-type: none"><li>• Contact HVAC service.</li><li>• Replace auxiliary contactor.</li></ul>
<b>Symptom #4 – Blower motor running backward</b>	
<ul style="list-style-type: none"><li>• Motor off by thermal overload (other fans forcing blower to spin).</li> <li>• Faulty capacitor.</li></ul>	<ul style="list-style-type: none"><li>• Determine if the cooling blower (or fans) are operating. If not, verify voltage to the cooling blower. If voltage is present, replace the cooling blower motor. If voltage is not present, verify voltage through the thermal switch. If no voltage is present, replace the thermal switch.</li> <li>• Replace capacitor.</li></ul>

## MT3240 Series

---

### REFERENCE TABLES

#### HEATING ELEMENT RESISTANCE

Element	Resistance
208 volt 3 $\Phi$	2.95–3.27 $\Omega$
240 volt 3 $\Phi$	3.94–4.35 $\Omega$
220/380 volt 3 $\Phi$ + N	4.96–5.48 $\Omega$
230/400 volt 3 $\Phi$ + N	5.42–5.99 $\Omega$

#### PROBE RESISTANCE VS TEMPERATURE

MT3240					
200	93	679.2	400	204	886.55
250	121	732.2	450	232	937.70
300	149	784.7	500	260	988.45
350	177	836.75	550	288	1038.7