

CIRCUIT DIAGRAM

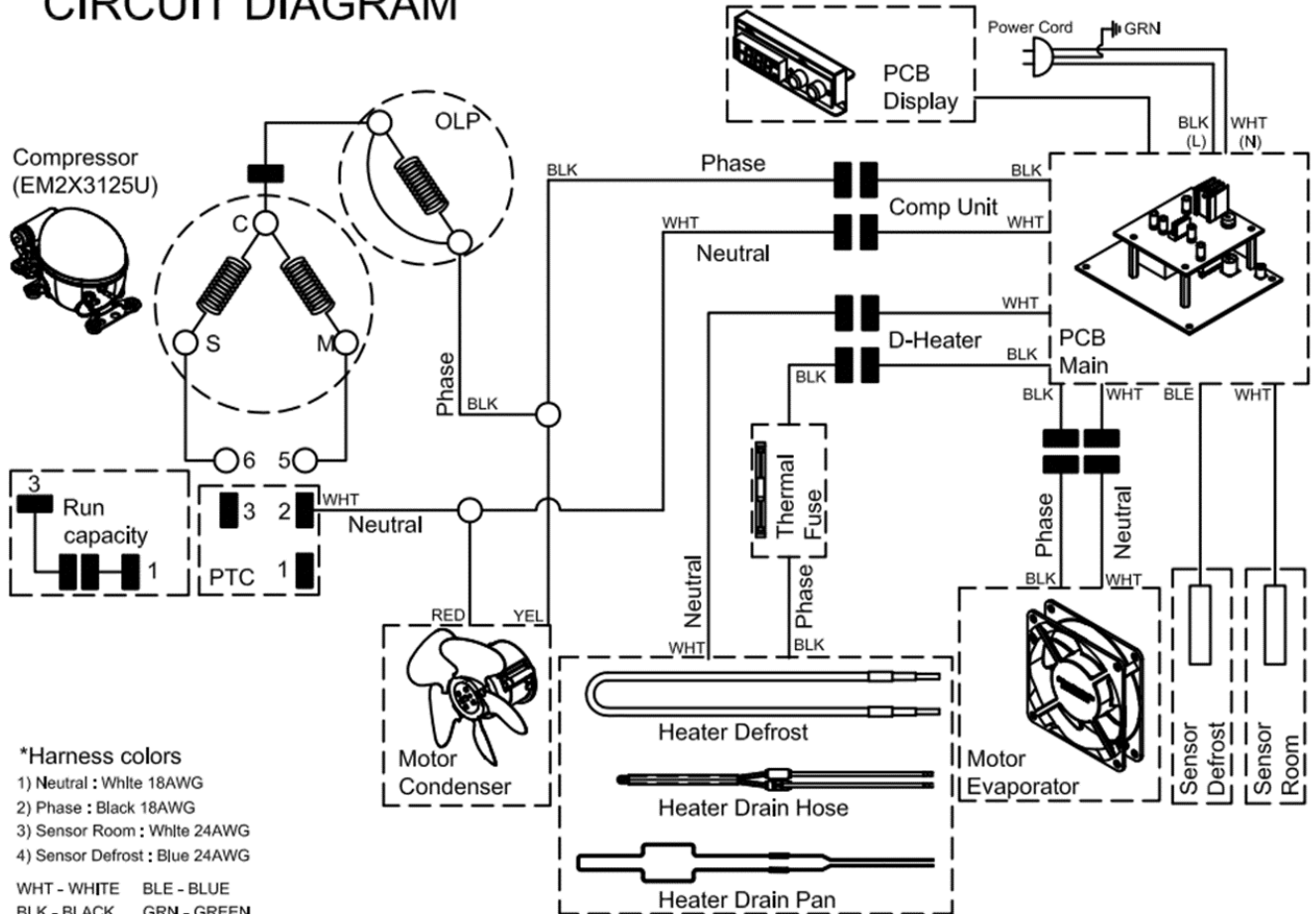

***Harness colors**
 1) Neutral : White 18AWG
 2) Phase : Black 18AWG
 3) Sensor Room : White 24AWG
 4) Sensor Defrost : Blue 24AWG

WHT - WHITE BLE - BLUE
 BLK - BLACK GRN - GREEN
 RED - RED YEL - YELLOW

(115V/60Hz)

*28F-HC

PCB LAYOUT

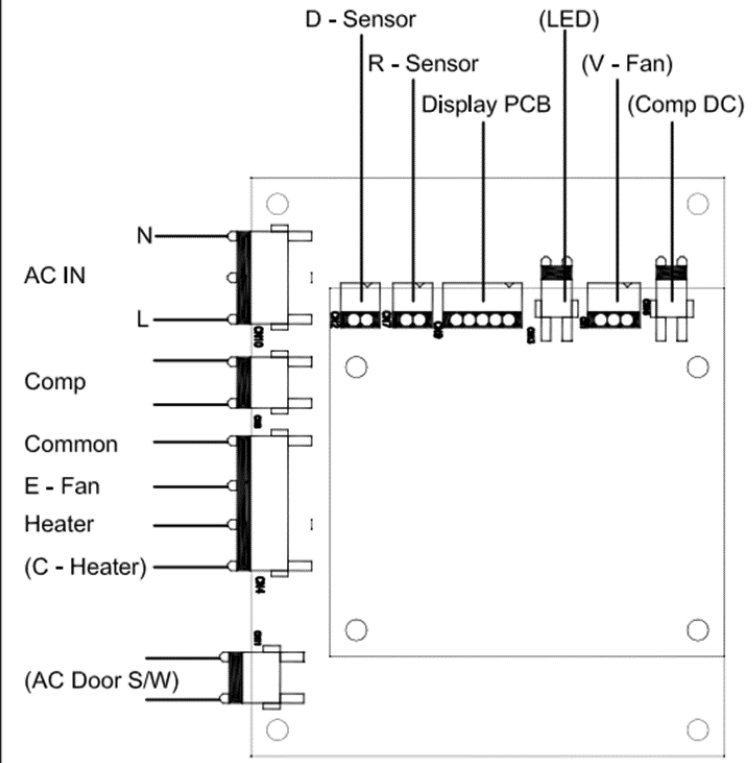

R510D-830