

10 Sunnen Drive
St. Louis, MO 63143
telephone: 314-678-6336
fax: 314-781-2714
www.bloomfieldworldwide.com

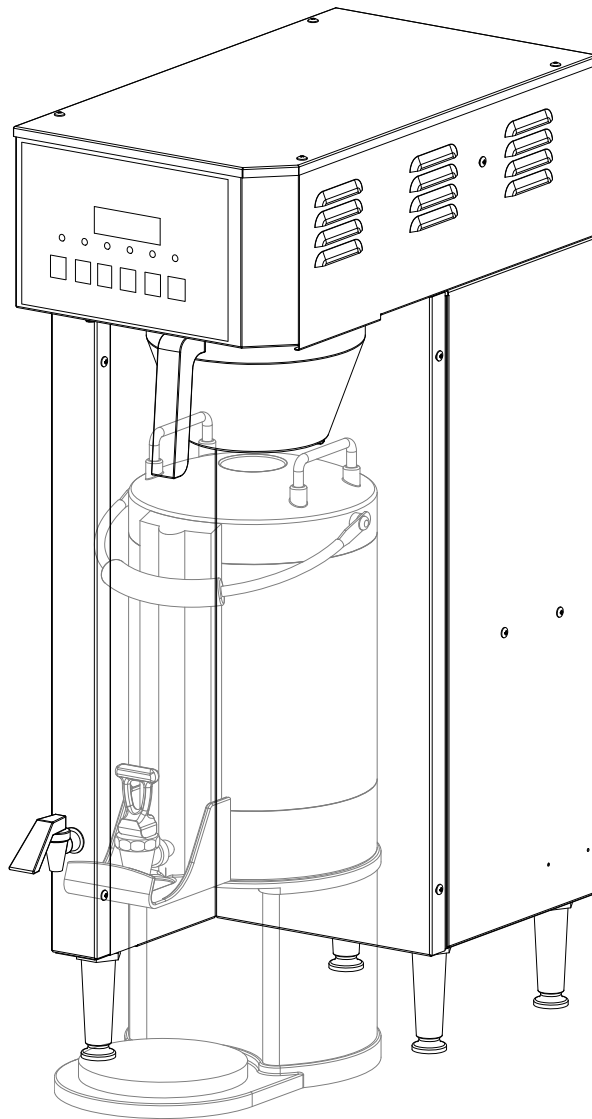

*Model 2795TF Single E-Max Thermal Brewer
(Servers Sold Separately)*

**OWNERS MANUAL
for**

**2795TF- SERIES
THERMAL
COFFEE BREWER
with
E-Max
CONTROL**

**MODEL:
2795TF**

Includes:

**Installation
Operation
Use & Care
Servicing Instructions
Exploded View & Parts List**

WARRANTY STATEMENT

All equipment manufactured by Bloomfield is warranted against defects in materials and workmanship for the time periods listed in the chart starting from the date the equipment is placed into service and is for the benefit of the original purchaser:

THE FOREGOING OBLIGATION IS EXPRESSLY GIVEN IN LIEU OF ANY OTHER WARRANTIES, EXPRESSED OR IMPLIED, INCLUDING ANY IMPLIED WARRANTY OF MERCHANTABILITY OR FITNESS FOR A PARTICULAR PURPOSE, WHICH ARE HEREBY EXCLUDED.

BLOOMFIELD, LLC SHALL NOT BE LIABLE FOR INDIRECT, INCIDENTAL OR CONSEQUENTIAL DAMAGES OR LOSSES FROM ANY CAUSE WHATSOEVER.

This warranty is void if it is determined that upon inspection by an authorized service agency that the equipment has been modified, misused, misapplied, improperly installed, or damaged in transit or by fire, flood or act of God.

It also does not apply if the serial nameplate has been removed or unauthorized service personnel perform service. The prices charged by Bloomfield for its products are based upon the limitations in this warranty. Seller's obligation under this warranty is limited to the repair of defects without charge by a Bloomfield Authorized Service Agency or one of its sub-agencies. This service will be provided on customer's premises for non-portable models. Portable models (a device with a cord and plug or a dispenser) must be taken or shipped to the closest authorized service agency, transportation charges prepaid, for services.

Agencies are located in principal cities, please visit our website to locate one.

This warranty is valid in the United States and Canada and void elsewhere. Please consult your classified telephone directory or your food service equipment dealer; or, for information and other details concerning warranty, write to:

Service Parts Department; Bloomfield
10 Sunnen Drive, St. Louis, MO 63143
Phone: (314) 678-6336 : Fax: (314) 781-2714
Technical@ bloomfieldworldwide.com / www.bloomfieldworldwide.com

Equipment	Parts	Labor
pour over, automatic coffee brewers	2 yrs.	2 yrs.
EBC, EMAX coffee brewers	2 yrs.*	2 yrs.
* EBC, EMAX coffee brewer control	3 yrs.	no labor
POD coffee brewers	1 yr.	1 yr.
ECO coffee brewers	1 yr.	1 yr.
coffee warmers	1 yr.	1 yr.
tea brewers	2 yrs.	2 yrs.
tea dispensers	1 yr.	1 yr.
tea dispenser BBTea	1 yr.	no labor
hot water machines	2 yrs.	2 yrs.
thermal servers	90 days	no labor
airpots	30 days	no labor
decanters	no warranty	no warranty

BLOOMFIELD SERVICE POLICY AND PROCEDURE GUIDE ADDITIONAL WARRANTY EXCLUSIONS

1. Resetting of safety thermostats, circuit breakers, overload protectors, or fuse replacements.
2. All problems due to operation at voltages other than specified on equipment nameplates - conversion to correct voltage must be the customer's responsibility.
3. All problems due to electrical connections not made in accordance with electrical code requirements and wiring diagrams supplied with the equipment.
4. Replacement of items subject to normal wear, to include such items as knobs and light bulbs. Normal maintenance functions including adjustment of thermostats, microswitches, and replacement of fuses and indicating lights are not covered under warranty.
5. All problems due to inadequate water supply, such as fluctuating, or high or low water pressure.
6. All problems due to mineral/calcium deposits, or contamination from chlorides/chlorines. De-liming is considered a preventative maintenance function and is not covered by warranty.
7. Full use, care and manuals may or may not be sent with each unit, only a condensed version. Please visit our web site to download the full version.
8. Travel mileage is limited to fifty (50) miles from an authorized service agency or one of its sub-service agencies.
9. All labor shall be performed during normal working hours. Overtime premium shall be charged to the customer.
10. All genuine Bloomfield replacement parts are warranted for ninety (90) days from date of purchase on non-warranted equipment. **Any use of non-genuine Bloomfield parts completely voids any warranty.**
11. Installation, labor and job checkouts are not considered warranty.
12. Charges incurred by delays, waiting time or operating restrictions that hinder the service technicians ability to perform services are not covered by warranty. This includes institutional and correctional facilities.

SHIPPING DAMAGE CLAIMS PROCEDURE

NOTE: For your protection, please note that equipment in this shipment was carefully inspected and packaged by skilled personnel before leaving the factory. Upon acceptance of this shipment, the transportation company assumes full responsibility for its safe delivery.

IF SHIPMENT ARRIVES DAMAGED:

1. **VISIBLE LOSS OR DAMAGE:** Be certain that any visible loss or damage is noted on the freight bill or express receipt, and that the note of loss or damage is signed by the delivery person.
2. **FILE CLAIM FOR DAMAGE IMMEDIATELY:** Regardless of the extent of the damage.
3. **CONCEALED LOSS OR DAMAGE:** if damage is unnoticed until the merchandise is unpacked, notify the transportation company or carrier immediately, and file "CONCEALED DAMAGE" claim with them. This must be done within fifteen (15) days from the date the delivery was made to you. Be sure to retain the container for inspection.

Bloomfield cannot assume liability for damage or loss incurred in transit. We will, however, at your request, supply you with the necessary documents to support your claim.

TABLE OF CONTENTS

WARRANTY STATEMENT	xi
SPECIFICATIONS	1
FEATURES & OPERATING CONTROLS	2
GENERAL INFORMATION & PRECAUTIONS	4
AGENCY APPROVAL INFORMATION	4
INSTALLATION	5
OPERATION	6
CLEANING INSTRUCTIONS	10
SERVICING INSTRUCTIONS	12
TROUBLESHOOTING SUGGESTIONS	19
E-MAX T™ TEST PROGRAM	20
EXPLODED VIEWS	22
WIRING DIAGRAM	26

Thank You for purchasing this Bloomfield appliance.

Proper installation, professional operation and consistent maintenance of this appliance will ensure that it gives you the very best performance and a long, economical service life.

This manual contains the information needed to properly install this appliance, and to use, care for and maintain or repair the appliance in a manner which will ensure its optimum performance.

SPECIFICATIONS

Model	Volts	Hr	Watts	Amps	Phase	Power Cord
2795TF	120V	50/60	1550	12.9	1	5-15P
	120/240V 3/W N	50/60	3050	12.7		None

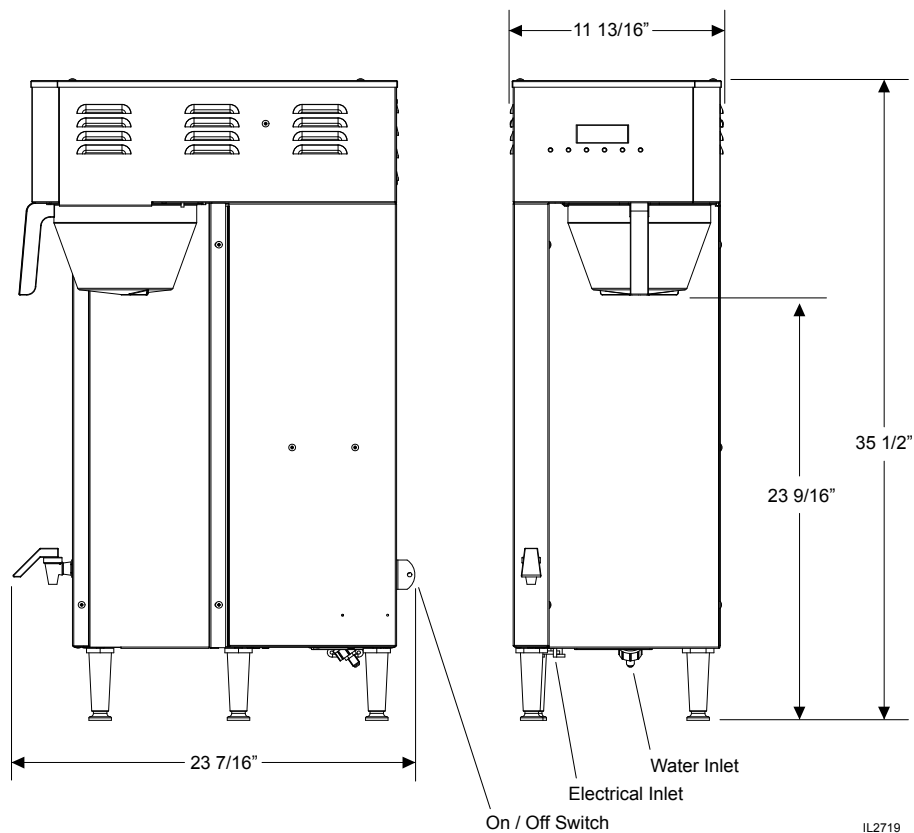

2795TF SHOWN ABOVE

FEATURES AND OPERATING CONTROLS

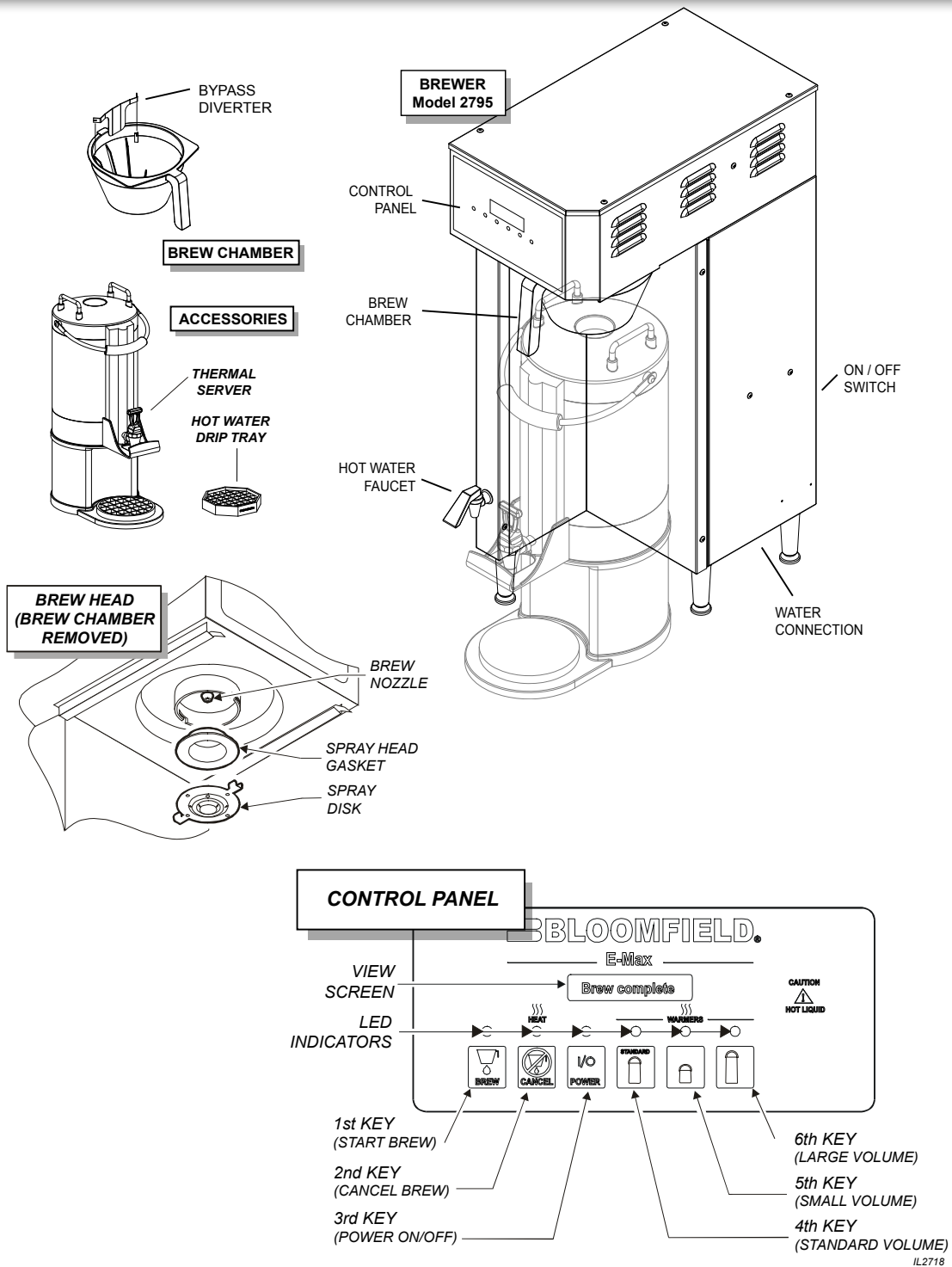

Fig 1. 2795 E-Max Thermal Brewing System; Features & Operating Controls

FEATURES AND OPERATING CONTROLS (continued)

Brewer

Adjustable Legs	Allows brewer to be leveled. Also allow clearance for cleaning underneath brewer.
Brewing Controls	Start or stop brew and select brew volume.
Bypass Valve	Dilution water flows into brew chamber channel from here. Dilution water DOES NOT flow through the coffee grounds.
Hot Water Faucet	Hot water dispensed here.
Nameplate	Lists manufacturer, model and serial number. Also lists voltage and wattage rating of brewer.
Ready-To-Brew Light	Glowes when the tank water is up to temperature.
System Switch (not shown)	Located on lower right rear of brewer. Turns main power to brewer <i>ON</i> or <i>OFF</i> .

Brew Chamber

Brew Chamber	Holds coffee grounds during brew cycle.
Bypass Diverter	Forms dilution flow channel by holding filter clear of the brew chamber wall.

Thermal Server

(sold separately)

Brew-Thru Lid	Allows entry of brewed coffee and dilution water into thermal. Minimizes splashing in the event satellite is tipped.
Handles	Allow the thermal to be safely carried.
Nameplate	Lists manufacturer, model and serial number.
Serving Faucet	Fresh coffee dispensed from thermal brewer here.
Sight Glass	Check the level of coffee remaining here.
Drip Tray	Catches drips and spills from the thermal server and the waffle grid is easily removed for easy cleaning.

Drip Tray (optional)

Optional drip tray catches drips and spills from hot water faucet. Easily removed for cleaning.

GENERAL INFORMATION AND PRECAUTIONS



WARNING: SHOCK HAZARD

All servicing requiring access to non-insulated electrical components must be performed by a factory authorized technician.

DO NOT open any access panel that requires the use of tools. Failure to follow this warning can result in severe electrical shock.



CAUTION: BURN HAZARD

Surfaces of this brewer can be hot and can cause burns on contact.

This appliance is intended for use in commercial establishments only.

This appliance is intended to brew hot beverage, specifically coffee, for human consumption. No other use is recommended or authorized by the manufacturer or its agents.

Operators of this appliance must be familiar with the appliance use, limitations and associated restrictions. Operating instructions must be read and understood by all persons using or installing this appliance.

Cleanliness of this appliance is essential to good sanitation. Read and follow all included cleaning instructions and schedules to ensure the safety of the food product.

Surfaces of the brewer, brew basket and servers can be hot to the touch, and may cause burns on contact.

Disconnect the brewer from electrical power before performing any maintenance or servicing.

DO NOT submerge servers in water.

DO NOT splash or pour water over, onto or into any controls, control panel or wiring.



Any procedure which requires the use of tools must be performed by a qualified technician.

This manual is considered to be a permanent part of the appliance. This manual and all supplied instructions, diagrams, schematics, parts breakdown illustrations, notices and labels must remain with the appliance if it is sold or moved to another location.

This appliance is made in the USA. Unless otherwise noted, this appliance has American sizes on all hardware.

AGENCY APPROVAL INFORMATION



This single thermal brewing system is  listed under E9253 and  listed under E9253.



This single thermal brewing system meets NSF Standard 4 only when installed and maintained per the instructions in this manual.



INSTALLATION INSTRUCTIONS

INSTALL LEGS

The brewer is provided with 4" adjustable legs and rubber feet. Be sure the legs are securely screwed into the base of the brewer, and that the rubber feet are properly installed.

LEVEL THE UNIT

The adjustable legs allow the brewer to be leveled. Set the brewer in its ultimate operating location and check for level with a spirit level. Adjust the brewer for level from front-to-rear, and from side-to-side. Be sure all four feet rest firmly on the counter.

PLUMBER'S INSTALLATION INSTRUCTIONS

IMPORTANT:

This equipment must be installed in accordance with the Basic Plumbing Code of the Building Officials and Code Administrators International (BOCA), and the Food Service Sanitation Manual of the Food and Drug Administration (FDA). Also, this equipment installation must comply with all local plumbing codes and ordinances.

IMPORTANT:

Brewer must be installed on a water line with a full-flow pressure between 20 psi and 90 psi.

NOTE: If water pressure varies greatly, or exceeds 90 psi at any time, a water pressure regulator must be installed. Plumbing installer must supply the regulator.

Brewer must be connected to a portable water supply. Bloomfield recommends not less than 1/4" copper tubing for installations of 12' or less, and not less than 3/8" copper tubing for installations exceeding 12'. Brewer must be connected to a COLD water line.

NOTE: DO NOT use a saddle tap for this water line connection.

A shut-off valve must be installed between the main water supply and the brewer. Plumbing installer must supply the shut-off valve. A 1/4-turn ball valve is recommended.

Bloomfield highly recommends the use of the provided water strainer to help prevent deposits in the brewing system.

Flush the water line before connecting to the brewer.

ELECTRICIAN'S INSTALLATION INSTRUCTIONS

Brewer requires a dedicated single-phase circuit:

Model 2795TF 120/208-240 Volt AC, 50-60 Hz
22.9 / 25.2 Amp circuit
3-Wire (L1, L2, N plus Gnd)

NOTE:

To enable the installer to make a quality installation and to minimize installation time, these tests and suggestions should be completed before the actual installation is begun.



CAUTION: UNSTABLE EQUIPMENT HAZARD

Legs must be adjusted so that all four feet rest firmly on the counter. Failure to properly install the feet can result in movement of the brewer, which can cause personal injury and/or damage to the brewer.

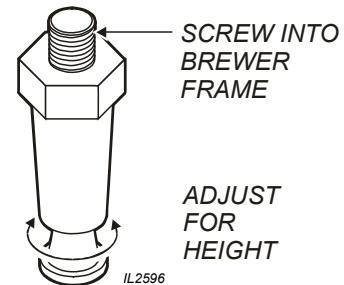

Fig. 2 Adjustable Legs



CAUTION: SHOCK HAZARD

Brewer must be properly grounded to a reliable earth ground to prevent possible shock hazard. Do not assume a plumbing line will provide such a ground. Electrical shock may cause serious injury.

OPERATION

OPERATING INSTRUCTIONS

IMPORTANT:

All E-Max T brewers are tested and set at the factory. If programming adjustments are necessary, refer to the E-Max Programming Manual (p/n 2M-73674).

To over-ride the Brew Wait mode, press and hold the BREW key for 3 seconds when the brewer is in Brew Wait mode (i.e. when brew light is flashing). The brew will proceed immediately regardless of water temperature. This feature should only be used when testing water volume, otherwise the brew will proceed with the water below the precise brew temperature.

Note: the following safety features have been incorporated to prevent multiple unattended brews:

The brew key is disabled during a brew cycle. This minimizes the possibility of double brewing.

When the "Brew" light is on or flashing, repeated pressing of the BREW switch will be ignored, (there will be a beep each time it is pressed). A Brew will only be activated when the "Brew" light is off.

- 1. Energizing the Brewer:** When electricity has been connected to the unit, there will be a momentary flash of the power light.

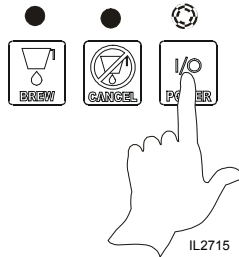

Turn the brewer on by pressing the POWER key. The brewer will start to fill the tank. With the proper water supply the tank should be filled in about 2½ minutes. Once filled, the heating element will come on until the proper tank temperature has been reached, (which will take about 20 minutes on 120-Volt models or about 12 minutes on 120/240 Volt models).

- 2. Brewing (Precise Temperature for Brewing — PTB):** In the regular operating mode, the E-Max T maintains the tank temperature within +/- 1°F of the brew temperature. Normally this will mean that a brew will be started as soon as the BREW key is pressed. However, there may be a slight delay if the BREW key is pressed immediately after a brew has been completed (notably on 120 volt models). If the tank temperature is below the brew temperature, the brew will be delayed,

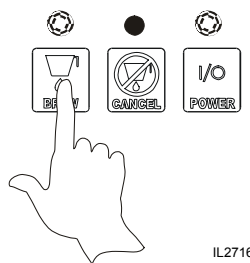

going into the "Brew Wait" mode, with the brew light flashing. As soon as the correct temperature is reached the brew will commence with the brew light on continuously during the brew. When the brew begins the main warming station will be turned on automatically (if it is not already on). During the brew cycle, if the BREW key is pressed, it will be ignored. Only when the brew is complete can another brew be started.

- 3. Brew Cancel:** To cancel a brew in progress, press the CANCEL KEY: two beeps will sound and the "Brew" light will go out. Water flowing to the brew chamber will be stopped immediately, but if there is already water in the brew chamber, it will take a few moments before this drips through as coffee.



- 4. Normal Operation (Non Brewing):** When the unit is not brewing, the E-Max T maintains the water temperature at the Precise Temperature for Brewing (PTB). The heating element will cycle on and off automatically to maintain this temperature.
- 5. After Hours Mode:** If no brew is detected for a pre-selected length of time, the brewer will enter the After Hours mode. Temperature will be allowed to drop to save energy. Pressing the BREW KEY returns the brewer to normal operation.

USER'S GUIDE

1. Remove the **brew chamber** from under the spray head. Place one (1) genuine Bloomfield paper filter into the brew chamber. Add your choice of measured coffee grounds. Shake the brew chamber gently to level the grounds flat. Slide the brew chamber back into place.

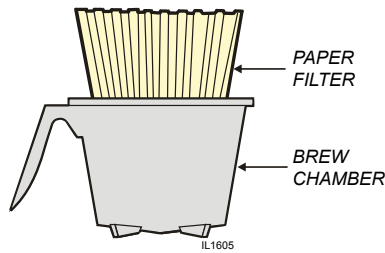

WARNING: Burn Hazard

This appliance dispenses very hot liquid. Serious bodily injury from scalding can occur from contact with dispensed liquids.

2. Place an empty **dispenser** under the brew chamber.

3. If any volume other than "Standard" brew volume is required, press the appropriate volume key.

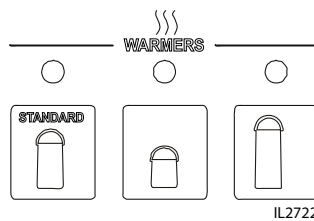

CAUTION: Burn Hazard

To avoid splashing or overflowing hot liquids, ALWAYS use an empty dispenser before starting the brew cycle. Failure to comply can cause serious burns.

4. To begin the brew cycle, press BREW key. Hot water will start spraying over the coffee grounds, and brewed coffee will start filling the server. Cold water will flow from the bypass valve to bring the coffee to the proper concentration. When the coffee stops flowing from the brew chamber, the fresh coffee is ready to serve.

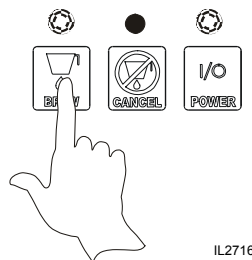

CAUTION: Burn Hazard

After a brew cycle, brew chamber contents are HOT. Remove the brew chamber and dispose of used filter and grounds with care. Failure to comply can cause serious burns.

NOTE: Brewing will not begin until the Precise Temperature for Brewing has been reached. (See page 6)

5. At the end of the brew cycle, the view screen will read "Brew complete". After all dripping has stopped, remove the brew chamber from the brewer. Discard the used paper filter and coffee grounds.

Brew complete



CAUTION: Burn Hazard

Exposed surfaces of the appliance, as well as brew chamber may be HOT to the touch, and can cause serious burns.

6. The brewer is now be ready to begin another brewing cycle.

OPERATION (continued)

PROGRAMMING FEATURES AND OPTIONS

1. **View Water Temperature in Tank:** To view the water temperature on the screen, E-Max T brewer must be ON, and not brewing or in the filling mode. Press and hold the 4th key, and depress the 6th key. The actual water temperature will be displayed for 3 seconds.
2. **Daily Brew Count:** The E-Max T maintains a count of the number of completed brews for a 7-day period. To access the count, turn the brewer OFF. In the OFF mode, press and hold the CANCEL key for 3 seconds. The current day and brew count will be displayed. Depress the ON/OFF key repeatedly to view each preceding day. When all 7 days have been displayed a 7-day total will be displayed. If you wish to exit the daily brew count before viewing all of the days, press CANCEL key.
3. **ON/OFF – Non Automatic Timer:** To turn the brewer OFF, press the ON/OFF switch: 2 beeps will be heard and the brewer will be turned OFF, indicated by all lights being off. To turn the brewer ON, press the ON/OFF switch: 2 beeps will sound, all lights will flash once, then the “Power” light will remain on, (the “Heat” light may come on if water temperature is too low).
4. **ON/OFF – Automatic Timer Feature:** The factory programmed E-Max T has the automatic timer turned off. To set the automatic timer, refer to the E-Max Programming Manual, “Time Functions” Menu. If the Automatic Timer feature is programmed off, the brewer can be turned on and off by depressing the ON/OFF switch, as noted above.
 - * When the Automatic Timer feature is programmed ON, the E-Max T will turn on and off automatically, at a programmed time, Monday to Friday; with a separate on and off programmed time schedule for Saturday and Sunday.
 - * Temporarily Overriding the Automatic ON/OFF function. While in the automatic timed OFF mode the brewer can be started by depressing the ON/OFF switch. The brewer will remain ON until the automatic programmed off time, when it will turn OFF and resume normal automatic timed functioning. Similarly, if turned OFF during the automatic timed ON mode the brewer will remain OFF until the next programmed on time, when it will turn on and resume normal automatic timed functioning.
5. **Automatic Start-Up in Previous Mode:** If the E-Max T automatic timer is OFF (the factory setting) and power is disconnected, the brewer will start up when power is restored, in the mode it had been in prior to the power disconnection. If the E-Max has the timer setting ON and power is disconnected, the brewer will start up in the mode that it should be in at the time the power is restored.
6. **Viewing Programmed Brew Volume:** The E-Max T can have up to 4 different brew volumes. When a volume other than the standard, or first brew volume, is selected, the E-Max will complete that volume and then automatically reset to the standard, or first brew volume. With the brewer ON, press and hold the CANCEL key. The 1st, or standard, volume will be displayed for 3 seconds (i.e. Volume #1 3 G), and then the day and time will be displayed.
7. **Changing Brew Volume:** Press the required volume key. If a volume is programmed for that key, the volume will be displayed on the screen for 3 seconds and the light above the key will be turned on. If no volume is programmed, the previous light will remain on and the screen will read “no volume prog” (i.e. no volume programmed). When a brew volume other than the 1st, or standard brew volume is selected, the E-Max T will complete the brew then return to the 1st or standard brew volume automatically.
 - a. With Volume Keys: Brewers with 3 volume keys can change brew volumes as outlined above
 - b. Without Volume Keys. For Brewers without volume keys, only one brew volume is normally programmed. To change the brew volume refer to E-Max Programming Manual.

8. Clock

- A. **Time – Battery Backup.** The E-Max T has a battery backup system which will maintain the proper time during power failures, or when the brewer is unplugged (even for very prolonged periods of time). Normally there will not be a need to set the time except for Daylight Saving Time changes, or moving the brewer to different time zones.
- B. **Changing Day and Time:** To change time, turn the E-Max T off. Press the 2nd key twice followed by the 1st key twice to access the time change mode, (i.e. press CANCEL, CANCEL, BREW, BREW). In the time change mode the screen will read “Day:” followed by the current day setting. Use the 6th key to advance the day, or the 5th key to reverse. When day has been properly set, press the 3rd key. The screen will now read “Time:” with the set time on the screen, the hour and am or pm flashing. Use the 5th key to go back or the 6th key to advance the hour, making sure that the am or pm is correct. When the hour and am/pm is correctly set, press the 3rd key, and the screen will read “Time:” with the set time on the screen, minutes flashing. As previously use the 5th or 6th keys to adjust the minutes, and press the 3rd key when complete. E-Max T will return to the off mode. (Changing time can also be done in the regular programming mode. Consult the E-Max *Programming Manual*)
- C. **After Hours:** Consult the E-Max Programming Manual to set the After Hours mode. The factory programming has the After Hours mode turned OFF. The After Hours can be programmed to come on from 1 to 6 hours after the last brew. When the E-Max T goes into the After Hours mode, the water in the tank will be allowed to drop from the normal brewing temperature and will reheat less frequently – this feature saves energy and extend component life. While in the After Hours mode, the power light will flash continuously. When the BREW switch is pressed the E-Max T automatically reverts back to normal operation, heating the water to the Precise Temperature for Brewing (PTB), before starting the brew. (The power light will be on continuously and the Brew light will flash until the correct water temperature is reached.)

9. **Countdown Quality Timer:** Refers to coffee warmers, not applicable for Thermal Brewers.

10. Pulse or Pre-Infusion Volume Options:

To set these features, refer to E-Max Programming Manual, Brew Settings Menu. If a particular brew volume has utilized the pulse or pre-infusion option, that volume will be displayed with an asterisk (*) after the volume. As an example “**Volume#2 3 G***” would indicate that the second programmed brew volume has utilized the pulse or pre-infusion program options.

DEFAULT PROGRAMS			
Type: Satellite	Position		
	1 Gal	1/2 Gal	1-1/2 Gal
Total Valve	215	142	322
Press 4th Key			
Init. Valve Time	30		
Pulse Delay	5		
Pulse Valve On	10		25
Bypass Tiem	150	20	200
Brew Complete	45	30	60

11. **Keypadlock:** This feature is OFF in the standard factory settings. To set the feature refer to E-Max Programming Manual, Machine Settings Menu. If the Keypadlock feature is activated, there will be no response by the brewer when the keys are depressed (except for the beep after a key is depressed). To temporarily “unlock” the keypad, press and hold the CANCEL key for 6 seconds. A beep will be heard indicating the keypad is now “unlocked”, — a brew can be initiated, warmer plates turned on or off, etc. The keypad will remain unlocked until the brew is completed, then automatically return to keypadlock mode. If a brew is not initiated 60 seconds after “unlocking”, the system will time out and return to the “locked” position.

Approximate Flow Rates
To determine brew time for a volume divide ounces by flow rate:
Brew Valve: .50oz sec
Bypass Valve .27oz sec

OPERATING INSTRUCTIONS (continued)

- 12. View Filter Statistics:** To view filter statistics, turn the brewer off. Press and hold the 1st key (Brew), and depress the 3rd (ON/OFF) key. Total water volume will be displayed (TotalVol.). Press the 3rd key to view the Filter Life (FltrLife:). Press the 3rd key to view the percentage of the filter that has been used. (If the filter option is used, the filter life volume needs to be entered in the program – see E-Max Programming Manual, Service & Counters Menu.)
- 13. Diagnostic Messages – Programmed Safety Features:** When E-Max T senses a problem, it will automatically turn off all elements and valves, flash lights, display the message “Call For Service” and display one of the messages below. (Additionally: a service phone number may appear if it has been programmed into the system.)
- * To reset the brewer it can be re-energized (or press and hold CANCEL for 3 seconds for all faults except the Valve Fault, which must be reset by re-energizing). The brewer will try to re-start, but if the same problem persists, the appropriate error message will appear again. Consult the Trouble Shooting section to determine how to solve the problem.
 - A. **“Probe/Heater Error”:** Overheating Detection (1): If the heating element is on for 5 minutes and the temperature does not change by +2°F (1°C) in the five minute period, the unit will go into the Over Temperature Mode with all lights flashing. When in this mode the brewer turns off the heating elements, the solenoid valves are turned off; the switches disabled; (and all lights flashing continuously). The LCD display will read **“Probe/Heater Error”**, followed by the message **“Call for Service”**, and then the service phone number (if it has been entered into memory). To reset press and hold CANCEL for 3 seconds, or re-energize the brewer. (Possible causes of problem: high limit needs to be re-set; defective high limit, element, triac, water level probe or control board.)
 - B. **“Overheat Error”:** Overheating Detection (2): If the E-Max senses a temperature over the Maximum Temperature set in the program (factory set at 208°F or 98°C) it will go into the over temperature mode as above with all lights flashing, except the LCD will read **“overheat error”**, and **“Call for Service”**. To reset press and hold CANCEL for 3 seconds, or re-energize the brewer. (Possible cause of problem is a defective triac, temperature probe or related wiring and connections.)
 - C. **“No Water Sensed” — Time-Out — Inlet Valve:** When filling for the first time, the inlet valve will remain open for 4¼ minutes, (the screen will read **“filling...”**). If water is not detected at the end of this time the E-Max will shut down with the message **“no water sensed”**. The valves and all elements are turned off, and the Brew and Power light flash alternately with the Heat light, until the brewer is reset. To reset press and hold CANCEL for 3 seconds, or re-energize the brewer. (Possible causes of the problem are: no incoming water; slow flow of incoming water (i.e. less than 45 oz/minute); sensor not reading (check for placement, connections or lime scale).)
 - D. **“No Water Sensed” — Time-Out – Brew Valve:** During the brew the inlet solenoid valve cycles on intermittently to maintain the proper level in the tank. If the valve is open for 60 seconds without water being detected at the proper level, the brewer will go into the same error mode as above (**“no water sensed”**). To reset press and hold CANCEL for 3 seconds, or re-energize the brewer. (Possible causes of the problem are: no incoming water; slow flow of incoming water, sensor not reading, etc.)
 - E. **Keyswitch Locked:** If a key switch is depressed for 10 seconds this error message will occur. Lights will flash alternately and the brewer will turn off all valves and elements. Press and hold the CANCEL key for 3 seconds to reset the brewer (or re-energize the brewer). If the problem re-occurs this indicates a defective switch on the key pad.
 - F. **“Valve Fault”- Faulty Valve Detection:** When an electric or switching problem is detected with either the inlet or brew valve the brewer turns off all elements and valves and displays **“valve fault...”**. All of the lights will be turned on. Before re-setting the brewer the valves must be checked to determine the problem. The brewer must be re-energized to re-set, (pressing CANCEL for 3 seconds will not reset a valve fault).

OPERATING INSTRUCTIONS (continued)

WATER FLOW

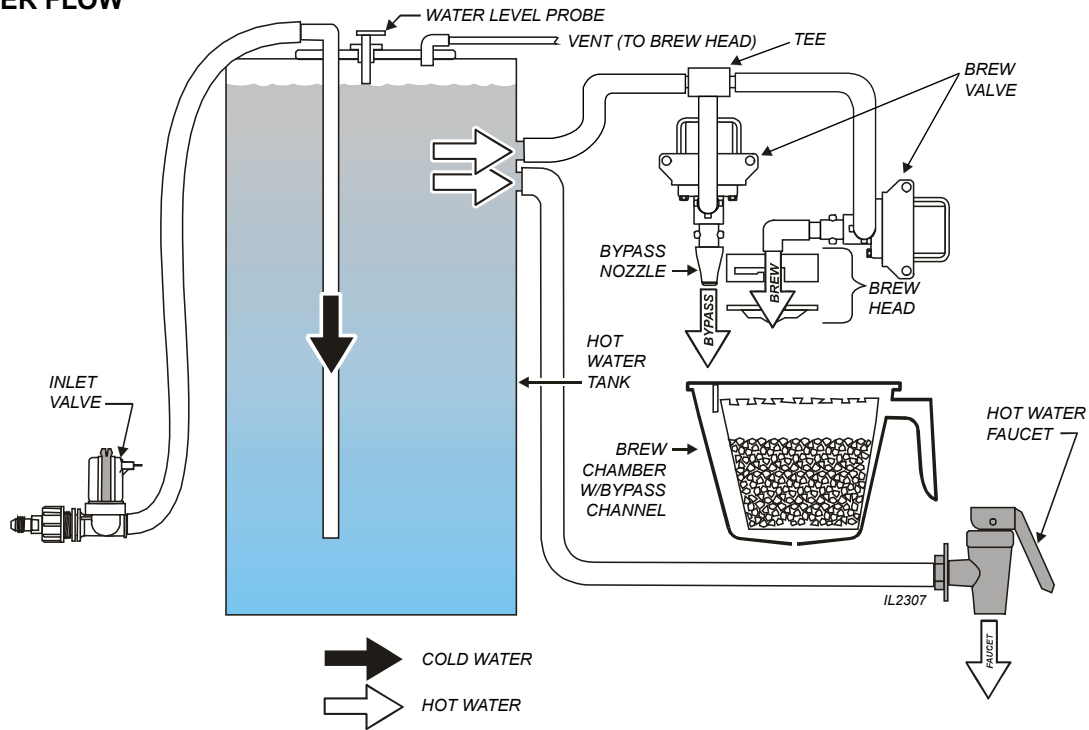

INLET

The INLET VALVE is controlled by a signal from the CONTROL BOARD. If the WATER LEVEL PROBE does not detect water, the inlet solenoid is opened until water is again sensed.

BREW AND BYPASS

The BREW VALVE is fed by gravity from the hot water tank. The brew valve is opened for a length of time as determined by the CONTROL setting. The brew valve discharges through the BREW HEAD:

- A portion of water is fed to the BYPASS through a reducing “tee”. The amount of bypass water is PRESET @ approx. .27oz per second. Bypass water flows through the brew basket, but is diverted from the grounds by a bypass channel.
- The remainder of the water is discharged through the BREW HEAD and flows over the grounds in the brew basket at a PRESET of approx. .50 oz per second.

HOT WATER FAUCET

The HOT WATER FAUCET is fed by gravity from the hot water tank. The faucet is spring-loaded closed and manually opened.

The hot water faucet is fed by the hot water tank, but is otherwise independent of the brewing systems.

NOTE:

Use of the hot water faucet during a brew cycle will not change the delivered volume. However, excessive use of the faucet during brew may lower the brew water temperature.

CLEANING INSTRUCTIONS



CAUTION: BURN HAZARD

Brewing and serving temperatures of coffee are extremely hot. Hot coffee will cause serious skin burns.

PROCEDURE: Clean Coffee Brewer

PRECAUTIONS: Press POWER key to OFF.
Allow brewer to cool.

FREQUENCY: Daily

TOOLS: Mild Detergent, Clean Soft Cloth or Sponge
Bristle Brush

IMPORTANT:

DO NOT use steel wool, sharp objects, or caustic, abrasive or chlorinated cleansers to clean the brewer, brew baskets or servers.

DO NOT immerse or submerge satellites in water.

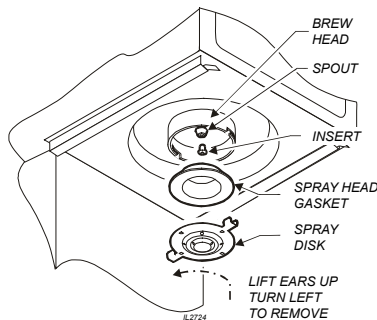

1. Disconnect brewer from electric power.
Allow brewer to cool.
 2. Remove servers.
 3. Remove and empty brew baskets.
 4. Remove spray disks and gaskets from spray heads
 5. Wipe inside of spray head and area around spray head with a soft clean cloth or sponge moistened with clean water.
 6. Wash spray disks in a sink using warm water and a mild detergent. A bristle brush may be used to clear clogged spray holes. Rinse spray disks with clean water and allow to air dry.
 7. Wash brew baskets in a sink using warm water and a mild detergent. A bristle brush may be used to clean around the bypass diverters. Rinse with clean water and allow to air dry. Be sure bypass diverters are properly installed.
 8. Wipe exterior of brewer and servers with a soft clean cloth or sponge moistened with clean water.
 9. Reinstall gaskets INSIDE brew heads, and then reinstall spray disks.
 10. Reinstall brew chambers.
 11. Reinstall servers.
- Procedure is complete

CLEANING INSTRUCTIONS (continued)

PROCEDURE: Clean Thermals

PRECAUTIONS: Drain Thermal before Cleaning

FREQUENCY: Daily

TOOLS: Sanitizer, Soft Clean Cloth, Bucket



CAUTION: BURN HAZARD

Brewing and serving temperatures of coffee are extremely hot. Hot coffee will cause serious skin burns.

1. Remove and drain thermals. Remove lids.
2. Remove funnel assembly and clean with mild detergent and warm water.
3. Fill Server 1/4 to 1/2 full with hot water, (use a non-caustic cleaning solution if appropriate).
4. Use a brush to clean the inside of the server.
5. Drain server, rinse & dry the outside surfaces with dry cloth.
6. Reinstall funnel assembly, lids & drip tray. Install satellites on brewer.
7. Rinse servers: with an empty brew chamber in place, press the BREW key and run 1 full cycle into each server.
8. Drain water from server.

Procedure is complete

IMPORTANT:

DO NOT submerge thermals in water.

IMPORTANT:

DO NOT use steel wool, sharp objects, or caustic, abrasive or chlorinated cleansers to clean the servers.

SERVICING INSTRUCTIONS



CAUTION: CHEMICAL BURN HAZARD

Deliming chemicals may be caustic. Wear appropriate protective gloves and goggles during this procedure. Never siphon deliming chemicals or solutions by mouth.

This operation should only be performed by qualified and experienced service personnel.

PROCEDURE: Delime the Water Tank

PRECAUTIONS: Disconnect brewer from electric power.
Allow brewer to cool.

FREQUENCY: As required (Brewer slow to heat)

TOOLS: Deliming Solution
Protective Gloves, Goggles & Apron
Mild Detergent, Clean Soft Cloth or Sponge
Bristle Brush, Bottle Brush
Large Sink (or other appropriate work area)

IMPORTANT: DO NOT spill, splash or pour water or deliming solution into or over any internal component other than the inside of the water tank.

IMPORTANT: DO NOT allow any internal components to come into contact with the deliming solution. Take care to keep all internal components dry.

NOTE: Repeat steps 4 and 7 as required to remove all build-up.

1. Disconnect brewer from the electrical supply.
2. Remove the brewer top panel, then remove the tank lid assembly. Do not disconnect the tank assembly at this time.
3. Drain all water from the hot water tank
(see *DRAINING HOT WATER TANK procedures*).
4. Mix 10 gallons of deliming solution according to the manufacturer's directions. Carefully pour the deliming solution into the water tank. Lower the lid assembly back onto the tank. Allow to sit for 30 minutes, or as directed by the chemical manufacturer.
5. At end of soaking period, reconnect brewer to electrical power. Install the brew chamber without filter paper or grounds. Place an empty server under the brew chamber. Force a 1-1/2 gallon brew:
 - a. Press the 1-1/2 gallon key
 - b. Press the brew key, then press and hold the brew key until a brew is initiated.Empty the server and **repeat for the other side**.
6. Disconnect brewer from electrical power and allow to cool.
7. Remove lid assembly from tank.
 - a. Using a stiff bristle brush, scrub internal components to remove lime and calcium build-up.
 - b. Thoroughly rinse internal components of lid assembly with clear water.
 - c. Store lid assembly in a safe location.
8. Using a stiff bristle brush, scrub exposed portions of the heating element and the inside surfaces of the tank to remove lime and calcium build-up.
9. Siphon all solution from the tank.

SERVICING INSTRUCTIONS (continued)

10. Reinstall tank lid assembly into hot water tank. Make sure the lid gasket is properly in place, then reinstall the hold-down clamps.
11. Remove spray disks and gaskets. Rinse both brew heads with clean water. Using a stiff brush, scrub spray disk to remove any lime or calcium build-up. Inspect gaskets and replace if it shows any loss of plasticity, reinstall gaskets and spray disks.
13. Reconnect brewer to electrical supply .
14. Install the brew chamber without filter paper or grounds.
15. Place an empty server under the brew chamber. Run at least five 1-1/2 gallon brew cycles and discard all water generated at the end of each cycle.
Repeat for the other side.
16. Rinse server with clean water. Reinstall one empty satellite under each brew chamber.

Brewer is ready to use.

DRAINING HOT WATER TANK

1. Disconnect brewer from the electrical supply
 2. Remove the top panel assembly (4 Screws)
 3. Remove the front panel assembly (4 Screws)
 4. Release the drain hose & hose clamp assy from the retaining clip.
 5. Bring the drain hose down out the front panel so its lower than the tank.
 6. Remove the red hose cap.
 6. Open the hose clamp and drain into container.
- CAUTION:** Tank holds 6 gallons of water and can may contain HOT WATER,
7. When tank is empty, close the hose clamp and place the red cap back into position.
 8. Place the end of the hose back into its retaining clip.

NOTE: Normally, silicone hoses do not need to be delimed. Should deliming hoses become necessary, Bloomfield recommends replacing the hoses.

IMPORTANT: DO NOT allow any internal components to come into contact with the any deliming solution. Take care to keep all internal components dry.

NOTES

TROUBLESHOOTING SUGGESTIONS

If the E-Max T goes into the error mode as outlined below, it will likely be necessary to reset the brewer in order to test individual components. Note the reset procedure below:

- For the first four error modes, press and hold CANCEL for 3 seconds, or RE-ENERGIZE the brewer by disconnecting from electric power for 5 seconds, then reconnecting.
- From “VALVE FAULT”, the brewer must be *RE-ENERGIZED!* Using the CANCEL button will not reset the brewer from “Valve Fault”.

The Test Program will also assist in isolating and testing specific components. As an example to test the three main components in the heater system, go to the test program and proceed to turn the “heater on”. Use a meter or test light to determine if power is getting to and from: the triac, the high limit and the element.

ERROR MESSAGE	CAUSE	SUGGESTIONS FOR REMEDIAL ACTION
1 “Probe/Heater” Error RESET by holding CANCEL switch for 3 seconds	Controller has turned heating element on for 5 minutes without sensing a +2°F change in water temperature.	1 Temp Probe may not be connected properly, or may be defective. CHECK & CORRECT. To test probe, go to Test Program and view probe value. A value of over 155 indicates a defective probe; a value of under 15 indicates a bad connection of the probe to the board. With an ohmmeter measure resistance of probe. At 212°F, resistance is approx. 2,000W If less than 1800W at room temperature probe is defective.
		2 May be boiling due to high altitude (boiling point below Brew Temp.) or Triac has failed ON and hi-limit has interrupted power to heating element. REDUCE BREW TEMP. CHECK TRIAC; REPLACE IF DEFECTIVE.
		3 Heating element defective. CHECK ELEMENT; replace if defective.
		4 Hi-limit thermostat may be cutting out at too low a temperature. CHECK HI-LIMIT THERMOSTAT; REPLACE IF DEFECTIVE. (Note; hi-limit will reset itself if allowed to cool by 30°F, making troubleshooting a challenge as the brewer cools then functions normally.)
		5 Heating element may be encrusted with lime or scale build-up. DELIME BREWER AS DETAILED ON PAGE 16.
2 “Overheat” Error RESET by holding CANCEL switch for 3 seconds	Water temperature has exceeded Maximum Water Temperature programmed into “Machine Settings” menu.	1 Brew Temperature may be set too close to Maximum Temperature. Brew Temperature should be at least 5°F below Maximum Water Temperature. LOWER BREW TEMPERATURE or RAISE MAXIMUM TEMPERATURE (Software versions after May, 1999 enforce the 5°F differential)
		2 Triac has failed ON; element continues to heat even when controller is OFF. CHECK TRIAC; REPLACE IF DEFECTIVE.
		3 Temp Probe defective. See probe test procedure in Item #1 above. CHECK PROBE; REPLACE IF DEFECTIVE.
3 “No Water Sensed” Error RESET by holding CANCEL switch for 3 seconds	Inlet valve energized but no water is sensed during regular operation for 60 seconds; or no water sensed during start-up (manual or timed) for 4½ minutes.	1 Sleeve on water level sensor is too long, or sensor is not pushed down fully. Sensor should extend beyond sleeve a minimum of ¼” to a maximum of 1”. REMOVE TANK LID, CUT SLEEVE TO PROPER LENGTH. ENSURE SENSOR IS PUSHED DOWN ALL THE WAY.
		2 Wiring to water level sensor disconnected or defective; or, sensor pulled out of tank. CHECK & CORRECT.
		3 Water level sensor may be encrusted with lime build-up. CLEAN SENSOR.
		4 Water supply may be OFF. CHECK & RESTORE WATER SUPPLY.
4 Keypad Locked” Error RESET as above	A switch on the keypad has been held down for more than 10 seconds.	1 Switch has been accidentally held for 10 or more seconds. RELEASE SWITCH
		2 Defective keypad. PRESS & HOLD “CANCEL” FOR 3 SECONDS. Observe brewer to determine if problem persists. (Note: available on software versions MFW 275 Rev. 3.4 and later versions only).
5 Valve Fault” Error RESET by disconnecting/reconnecting electric power	Detection of a problem with the valve switching system, or with the wiring to the valves.	1 Wiring to either inlet or outlet valve not properly connected. CHECK WIRING AND CONNECTIONS.
		2 The controller has two switches for each valve and one or both has been detected as failing ON. (This prevents the brewer from operating unless both switches are working properly.) REPLACE CONTROLLER.

E-Max T™ TEST PROGRAM

Remember: Exiting Test Program Mode:

To exit the Test Program, press the 2nd key (Cancel) at any time, except during the key switch tests below. Alternately, complete the full test and the E-Max T will return to the OFF mode.

Note: each key press should be followed by an audible beep.

Note: Bloomfield recommends that, should the keypad fail a test, the test be carefully repeated at least three times to verify the keypad failure.

Instructions for testing procedures for the following system components (using the E-Max T Built-In Diagnostic):

Electronic Board Software (Firmware) Revision
Keypad switches
LED's
Inlet valve, Dump (Brew) valve, By Pass Valve
Water level probe, Temperature probe

A. Entering Test Program Mode:

1. Make sure to have power to the system. Press the 3rd key to enter the OFF mode.
2. In the Off mode, hold down the 3rd (ON/OFF) and 4th keys (1st volume key or "E" in "E-Max T"). Hold both keys down for approximately 3 seconds.

If successful, a message containing the revision of the firmware will be displayed: (e.g. "MFW275T Rev 1.2")

3. Press the 3rd key.

B. Check Data Revision

1. The next display contains the revision number of the data programmed into the EEPROM: (e.g. "Data Rev1.2").
2. Press the 3rd key to continue.

C. Time

Time is preset

D. Switch Test - The keys are tested in this stage.

1. Test 1st key by pressing the "BREW" key. You will hear a beep, and the display will change to "Test Switch 2".
2. Test 2nd key by pressing the "CANCEL" key. You will hear a beep, and the display will change to "Test Switch 3"
3. Test the 3rd key by pressing the "ON/OFF" key. You will hear a beep, and the display will change to "Test Switch 4"
4. Continue by pressing the 4th key (1st volume key, or "E" in "E-Max T");
5. 5th key (2nd volume key, or "a" in "E-Max T"); and,
6. 6th key (3rd volume key, or "T" in "E-Max T")

Except for Switch 1, if a key press is not detected within five seconds, the "Switch Error" message Will be displayed followed by two beeps. For Switch 1, the time limit is 30 seconds.

If an error occurs when the correct key is pressed, the keypad has failed the test.

E. LED Test The display should read “Testing LED’s”:

Individual LED’s will be tested individually, beginning with the first on the left, and proceeding through all six LED’s at one-second intervals. Screen will read “Testing LED’s” during the entire test.

1. Verify that only one LED at a time is lit, and that each of the six LED’s light in their proper sequence.

L1	L2	L3	L4	L5	L6
BREW	CANCEL	ON/OFF	Volume 1 or “E”	Volume 2 or “a”	Volume 3 or “T”

2. Verify that each LED is the correct RED color:
3. When all lights have been tested, press the 3rd key (ON/OFF) to continue.

F. Output Test The valves and heater are tested in this stage. Display should read “Inlet 1 Off”:

1. Press the 3rd key. The inlet valve should turn on, and the display should read “Inlet 1 ON”
2. Continue pressing the 3rd key, in sequence, to advance through the component tests. Each component should turn ON then OFF in the following order:

Output 1	Inlet
Output 2	Dump
Output 3	Heater
Output 4	Bypass
Output 5	(Future - not functional at this time)
Output 6	(Future - not functional at this time)

3. Each component should turn ON in order, with only one component ON at a time. If the components fail to turn on in the proper sequence, or if a “Valve Fault” message is displayed, the controller has failed the test.

G. Probes Test This section ensures the proper functioning of the Water Level Probe and Temperature Probe:

1. The left number determines whether the WATER-sensing probe is in contact with water.
 - a. A number of “0” (or close to 0) means that water is in contact with the probe.
 - b. A number of 255 (or close to 255) means water is not in contact with the probe.
2. The right number represents what the reads. The table at right is an approximate correlation between the value and the temperature the probe is sensing. (Note a number less than 10 would indicate the probe is not properly connected to the board, while a number higher than 155 indicate a defective probe.)

Right Number	Approx. Water Temp.
< 10	Probe not connected
20	74°F
25	83°F
30	92°F
↓	↓
120	181°F
125	186°F
130	191°F
135	196°F
140	201°F
≥ 155	Defective Probe

H. Test Done. Indicates completion, press ON/OFF to reset controller. The controller should restart with the message “BLOOMFIELD”, then return to the OFF mode.

EXPLODED VIEW ; 2795TF CABINET AND EXTERIOR COMPONENTS

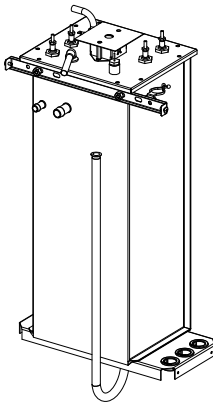
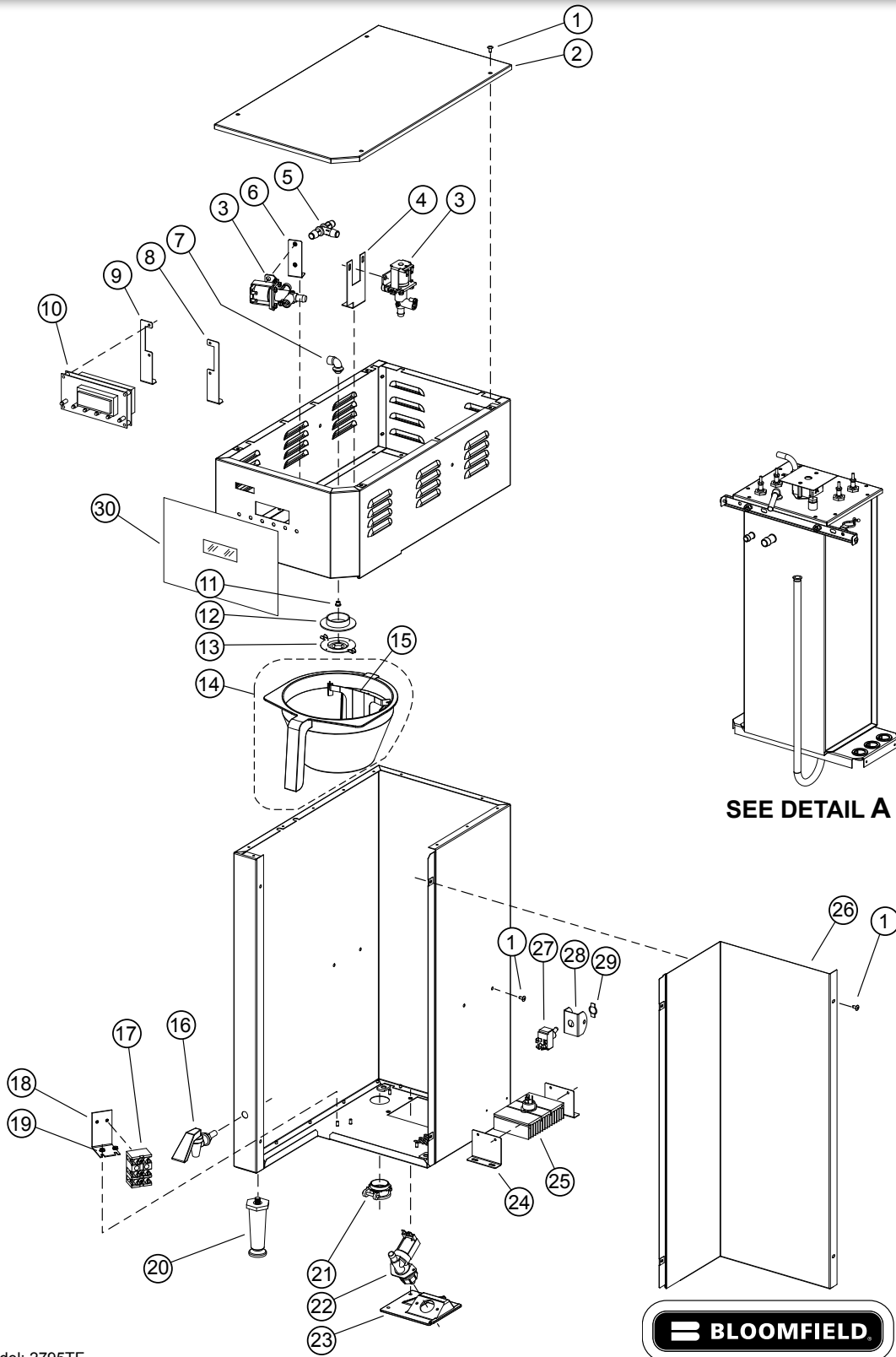

SEE DETAIL A

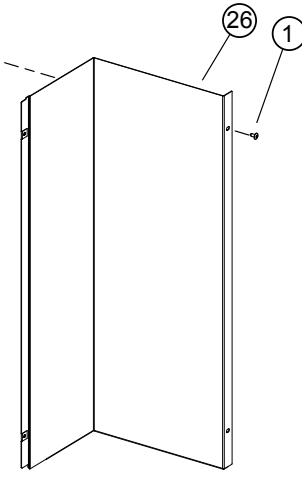

Model: 2795TF
E-Max Thermal Brewer

SK2731, Rev. - 12/23/13

PARTS LIST ; 2795TF CABINET AND EXTERIOR COMPONENTS

Model: 2795 E-Max Thermals Brewer				
Fig No.	Parts List	Qty	Description	Application
1	2C-6349	12	SCREW #8X3/8 B THP STL NP	
2	D7-Z16539	1	TOP COVER	
3	2V-73388	2	VALVE ADJ. WATER OUTLET	
4	D7-Z17807	1	BRACKET, BYPASS	
6	D7-76576	1	BRKT OUTLET VALVE	
7	2K-73152	1	ELBOW SPRAYER 1/4 ID	
8	D7-Z16740	1	BRKT BOARD MTG RIGHT EMAX	
9	D7-Z16739	1	BRKT BOARD MTG LEFT EMAX	
10	2E-Z17751	1	BOARD SET, CONTROL	
11	2G-73571	1	INSERT SPRAY HEAD SS2	
12	2I-72215	1	GASKET SPRAY HEAD 1.5 ID	
13	A6-72727	1	SPRAY HEAD DISC EMBOSSED	
14	D7-76652	1	CHAMBER BREW ASSY	
15	D7-Z16812	1	BRKT BYPASS PLASTIC BREW	
16	2U-71061	1	FAUCET HOT WATER	
17	2E-37465	1	TERM BLOCK 3POLE 85AMP	
18	D7-Z17065	1	BRKT- TERMINAL BLOCK	
19	2C-Z2594	2	NUT 6-32 HEX W STL NP	
20	2A-73098	4	LEG 4 BLK PLASTIC W/FLAN	
21	2K-300102	1	STRAIN RELIEF 1NPT.375-1.	240V
	2K-76118		STRAIN RELIEF	120V
22	2V-74427	1	SOLENOID SINGLE 120V 1.0	
23	2Q-75089	1	DOOR ACCESS PLASTIC	
27	Z1-70-07-0343	1	SWITCH GUARD	
28	2E-30330	1	SWITCH ON OFF TOGGLE 20A	
29	2E-33192	1	PANEL ON & OFF SWITCH	
30	2M-Z17916	1	KEYPAD SINGLE - THERMAL	
NI	2A-76574	1	TUBE BYPASS	
NI	2M-Z17591	1	DIAGRAM WIRE LABEL	240V
	2M-Z19069			120V
NI	A6-73537	3	TUBE SIL .312 ID X 9 LG	
NI	D7-Z16477	1	TUBE SILICONE .312 X 41.5	
NI	D7-Z17081	1	TUBE, SIL .500 ID 8.5	

EXPLODED VIEW ; 2795TF INTERIOR COMPONENTS

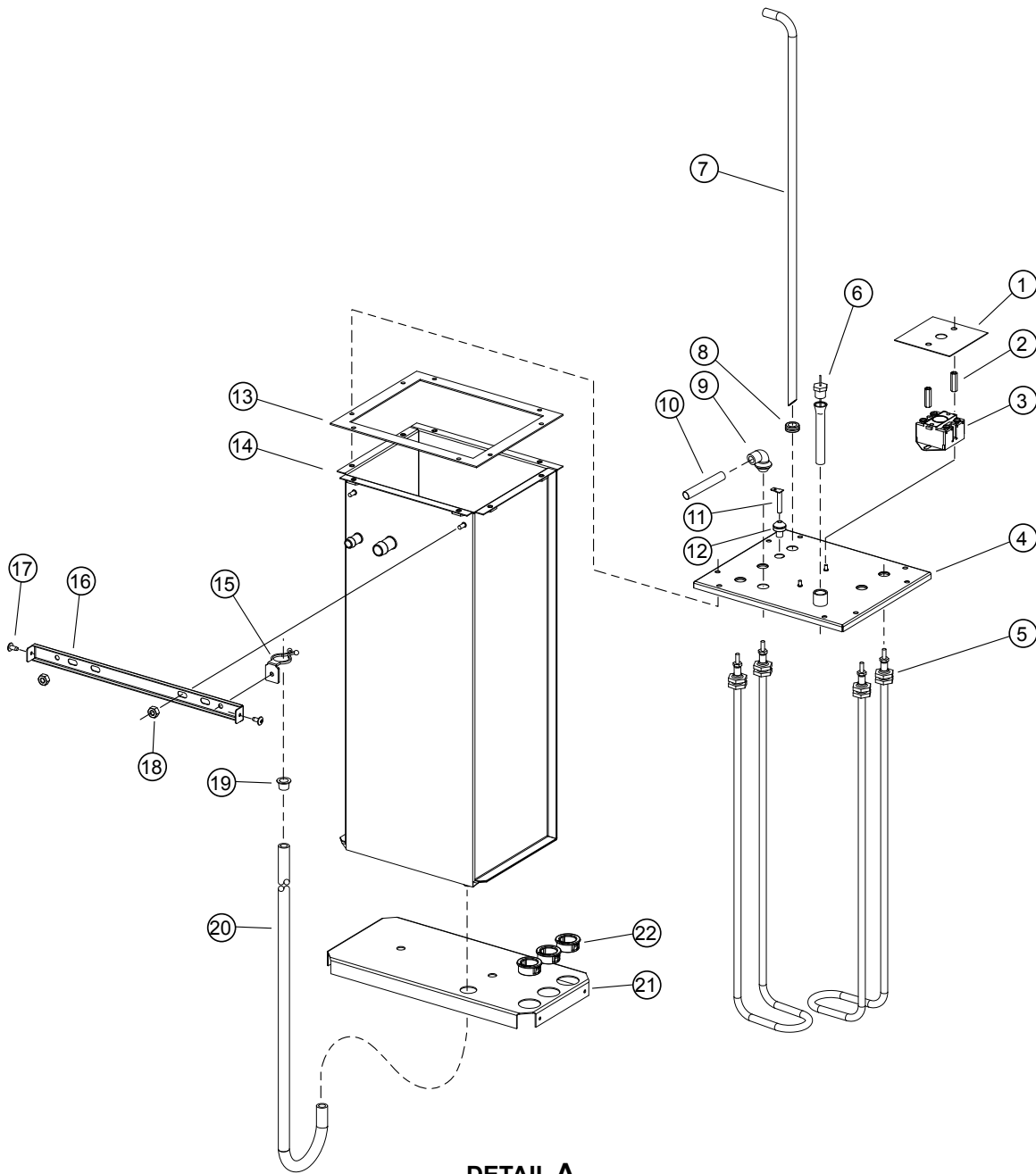

DETAIL A

Model: 2795TF
E-Max Thermal Brewer: Tank Assy



SK2732, Rev. - 12/23/13

655 2M-Z17970 Owners Manual E-Max Thermal Brewer

PARTS LIST: 2795TF INTERIOR COMPONENTS

Detail A: 2795 Tank Assy				
Fig No	Part No.	Qty	Description	Application
1	D7-73414	1	SHIELD HI-LIMIT	
2	2C-73415	2	NUT 6-32 HEX 1.00 LG ALUM	
3	2T-73312	1	THERMO HI LIMIT DBL POLE	
4	D7-WL0347	1	TANK COVER ASSY	
5	2N-76571UL	2	ELEM HEATIN 120V 1500W HW	240V
		1		120V
6	2J-73644	1	PROBE TEMPERATURE 5 1/2	
7	2A-74343	1	TUBE FILL 90 DEGREE	
8	2I-72390	1	GROMMET .375 ID TRANSLUCE	
9	2K-70103	2	ELBOW OUTLET	
10	2A-73384	3	TUBE SPRAY HEAD 2 3/8 LG	
11	A6-73521	1	PROBE ASSY WATER LEVEL	
12	2A-73532	1	SLEEVE WATER LEVEL PROBE	
13	2I-Z16545	1	TANK GASKET	
14	D7-WL0346	1	TANK WELDMENT	
15	2C-43914	1	TIE WIRE MTG STUD M4200-2	
16	D7-Z16559	1	BRACKET, TANK TOP	
17	2C-6349	2	SCREW #8X3/8 B THP STL NP	
18	2C-35485	2	NUT 1/4-20 HEX FINISHED S	
19	2P-306831	1	CAP PLUG PLASTIC .5 DIA.	
20	F4-73977	1	TUBE SIL .312 ID X 35	
21	D7-Z16537	1	TANK SUPPORT BOTTOM	
22	2K-Y5093	3	BUSHING-SNAP #SB-1000-12	
NI	2C-76564	1	CLAMP HOSE SHUT OFF	

WIRING DIAGRAM

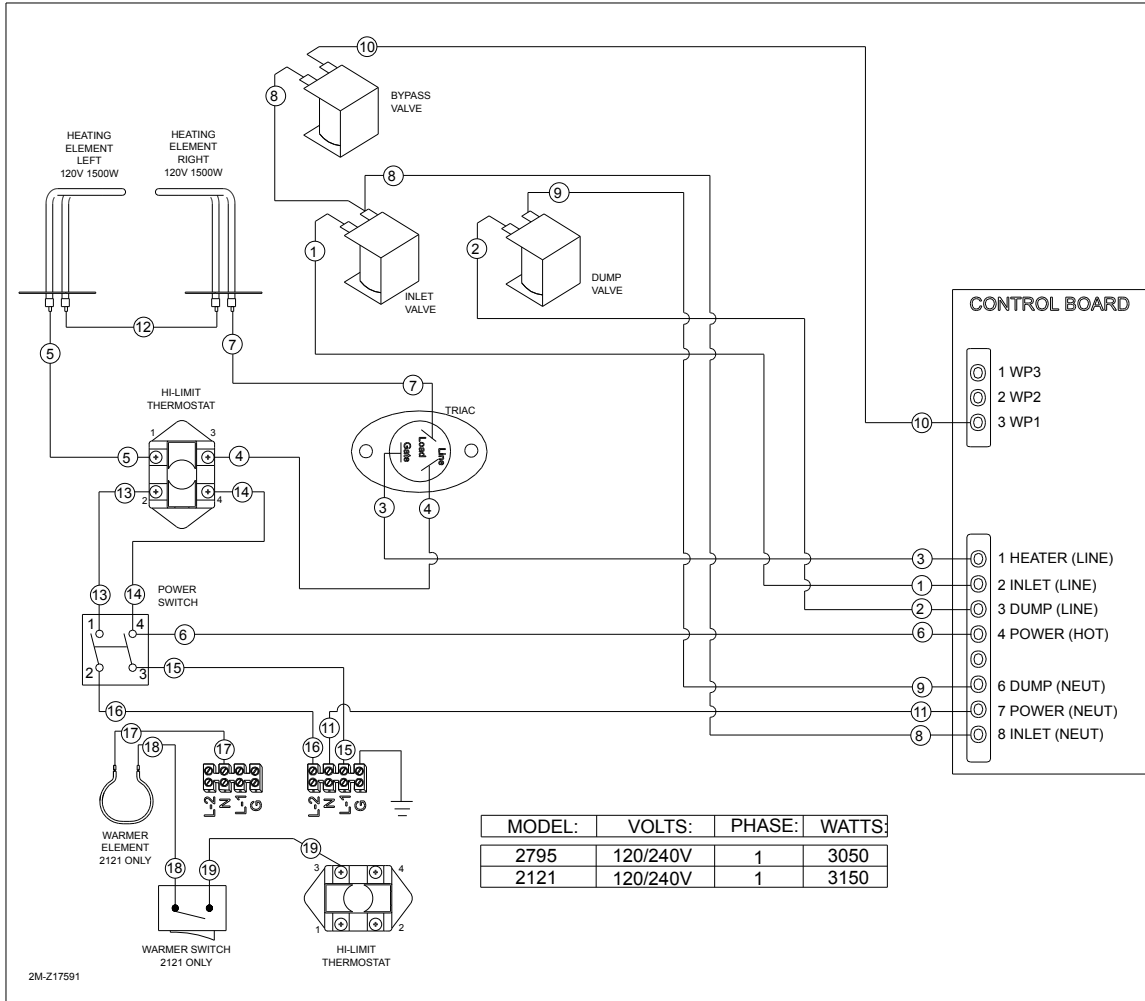

WIRING DIAGRAM

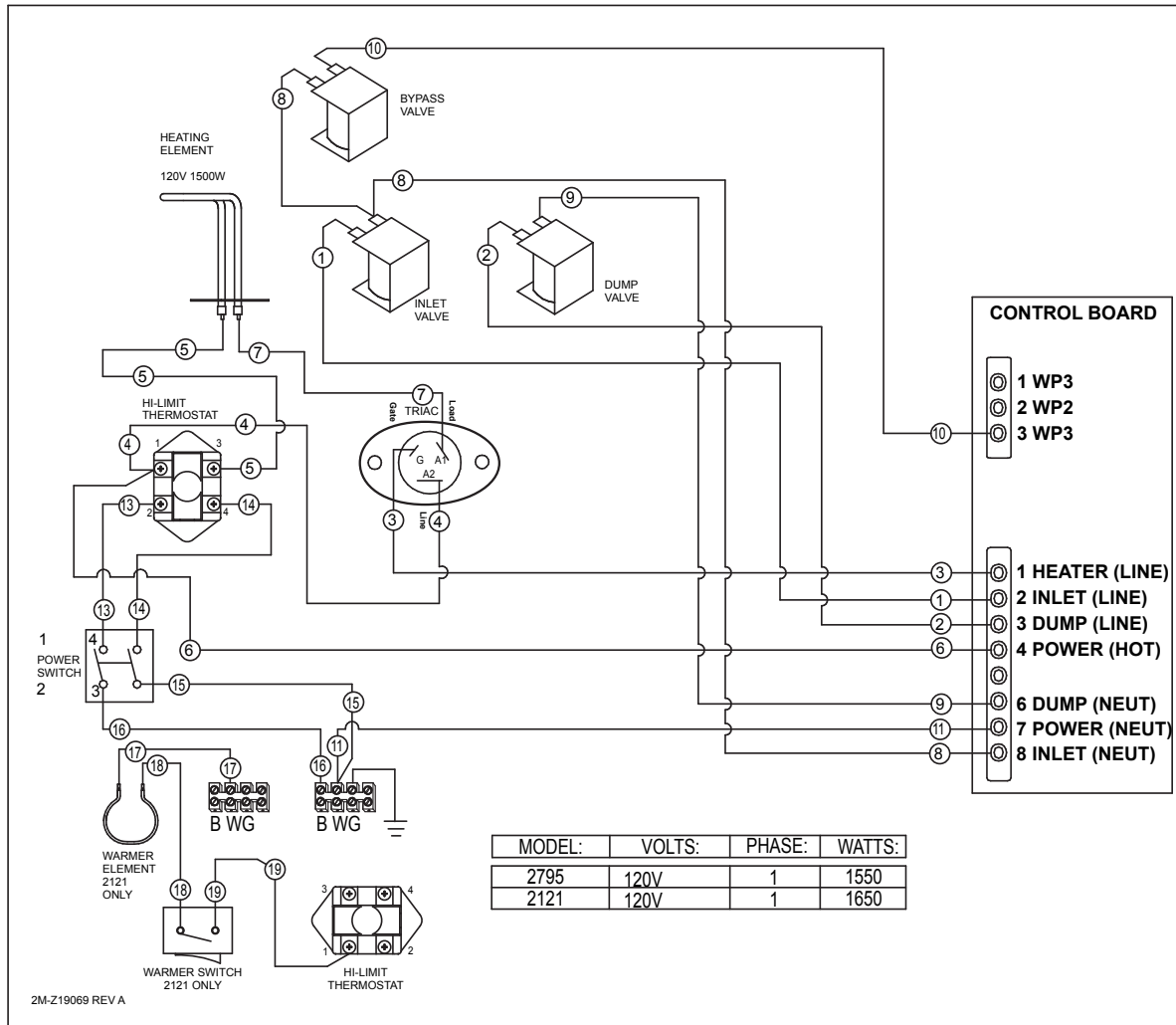



Wells Bloomfield proudly supports CFESA
Commercial Food Equipment Service Association

SERVICE TRAINING - QUALITY SERVICE



CUSTOMER SATISFACTION



10 Sunnen Drive, St. Louis, MO 63143
telephone: 314-678-6336 fax: 314-781-2714
www.bloomfieldworldwide.com