

BLAKESLEE

Division of The Legacy Companies

OWNER'S MANUAL

MODELS BB914, BB2016, BB1224 **BURNISHER**

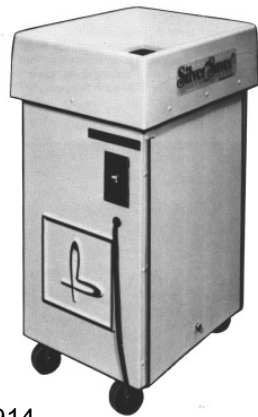

BB914



BB2016



BB1224

1228 Capitol Dr.
Addison, IL 60101
Phone (630) 532-5021
Fax (630) 532-5020

www.blakesleeinc.com
service@blakesleeinc.com

1149 Bellamy Road North Unit 19
Scarborough, Ontario Canada M1H1H7
Phone (416) 751-2625
Fax (416) 751-8539

Revised 01/2013

**BLAKESLEE**

Date of Installation _____

Serial
No. _____Model
No. _____

Limited Warranty

Your new Blakeslee burnisher is warranted for one year from date of installation shown above against defective materials and workmanship. If any defects are found within the warranty period; parts, and labor involved with their replacement will be covered free of charge. Service must be performed by a Blakeslee authorized service agency. All labor to be performed during regular working hours. Overtime premium will be charged to the customer. All warranty parts are shipped by surface transportation. If other means of transportation is requested the customer is required to pay the premium. This warranty does not apply to damages resulting from errors in installation on the part of other contractors, nor does it apply to machines which have been subject to accident, misuse, or abuse. It is understood that Blakeslee's warranty obligation with respect to machines located outside of the United States or located in the state of Alaska is limited to the furnishing of replacement parts only. In the state of Hawaii, repair labor is provided free of charge; travel time and expenses paid by the customer. On the island of Oahu, repair labor, travel time and expenses are provided free of charge. This is the entire and only warranty of Blakeslee. We neither assume nor authorize anyone else to assume for us any other obligation or liability in connection with Blakeslee Machines.

- In no case can this warranty exceed eighteen (18) months from the date of shipment from our plant at Addison, Illinois
- Tub lining is guaranteed for 3 years from date of installation. Service labor is not included in this extended warranty.

Your new Blakeslee product has been carefully manufactured and tested.

Occasionally you may experience a problem with your new machine and if it is due to a defective part or workmanship, we will be more than happy to repair it at no charge to you as stated in our guarantee.

Like any other piece of equipment that is being heavily used, the machine will require periodic cleaning and maintenance. This cleaning and maintenance is the owner's responsibility and is not covered under our warranty. The compound recirculating tank must be emptied and replenished every eight hours of use to prevent the waste material from damaging the pump seal. Compound and water must be in the tank whenever the machine is in operation to lubricate the seal of the pump.

TABLE OF CONTENTS

SECTION 1.	INTRODUCTION	1
	1-1. General	1
	1-2. Description	1
	1-3. Specifications	1
SECTION 2.	INSTALLATION	3
	2-1. Unpacking the Unit	3
	2-2. Installation	4
SECTION 3.	OPERATION	7
	3-1. General	7
	3-2. Preparing the compound	7
	3-3. Operation	7
	3-4. Draining and cleaning the Unit	8
SECTION 4.	MAINTENANCE	9
	4-1. Daily	9
	4-2. Monthly	9
	4-3. Bi-Monthly	9
	4-4. Replacing Tub Drain Screen	9
	4-5. Media Replacement	10
	4-6. Motor Belt Replacement & Adjustment	10
	4-7. Converting "V" Belt Drive to "O" Ring Drive	10
	4-8. Eccentric Bearing Replacement	11
	4-9. Media Tub Replacement	12
	4-10. Compound Pump	13
	4-11. Drive Motor Rotation	13
	4-12. Wiring Diagrams and Schematics	13
	4-13. Troubleshooting	14
SECTION 5.	ILLUSTRATED PARTS LIST	15

SECTION 1 INTRODUCTION

1-1. GENERAL

This manual covers Installation, Operation, and Maintenance Instructions and Illustrated Parts Lists for Blakeslee Burnishers – Models BB914, BB2016 and BB1224.

burnishing media and chemical compound that restores luster to stainless steel, silver, pewter, etc.

1-2. DESCRIPTION

The Blakeslee Burnisher uses a special procelain ceramic

These procelain ceramic burnishing balls are 1/3 lighter than steel balls, consequently all types of flat and hollow ware items can be burnished without damage. Knives and other items are not dulled no matter how long they remain in the machine.

1-3. SPECIFICATIONS

	BB914	BB2016	BB1224
Motor	1/2 H.P., 3450 RPM	1 H.P., 3450 RPM	1 H.P., 3450 RPM
Compound Pump	P:AAA (Constant) 6 GPH	P:AAA (Constant) 6 GPH*	P:AAA (Constant) 6 GPH*
Media Capacity	40 Lbs	160 Lbs	160 Lbs
Weight	140 Lbs, w/o media	265 Lbs, w/o media	265 Lbs, w/o media
Dimensions	20-3/4" l x 15-3/4" w x 35-5/8" h	20" l x 23" w x 35" h	37" l x 25" w x 30" h
Power Requirement	6 amp 115V	12 amp 115V	12 amp 115V
Tub Opening	9" x 14"	20" x 16"	12" x 24"

*Compound pumps on later model burnishers operate in conjunction with a 1 minute timer. When the burnisher is initially turned on, the pump will run for 2 minutes, then turn off.

SECTION 2 INSTALLATION

2-1. UNPACKING THE UNIT

1. Remove unit from shipping carton (See fig. 2-1.)
2. Lift unit from skid.
3. **MODEL BB914.** Remove media bags stowed in tub.
MODELS BB2016 and BB1224. Remove media bags stowed inside skid. (See fig. 2-2.)
4. **MODELS BB914 and BB2016.** To remove rear cover, push in and turn quick disconnect screws 1/4 turn counterclockwise. (See fig. 2-3.)
MODEL BB1224. To open front doors, push in and turn quick disconnect screws 1/4 turn counterclockwise. (See fig. 2-4.)
5. Remove compound tank from unit. (See fig. 2-5.)
Remove packing material and compound from tank.

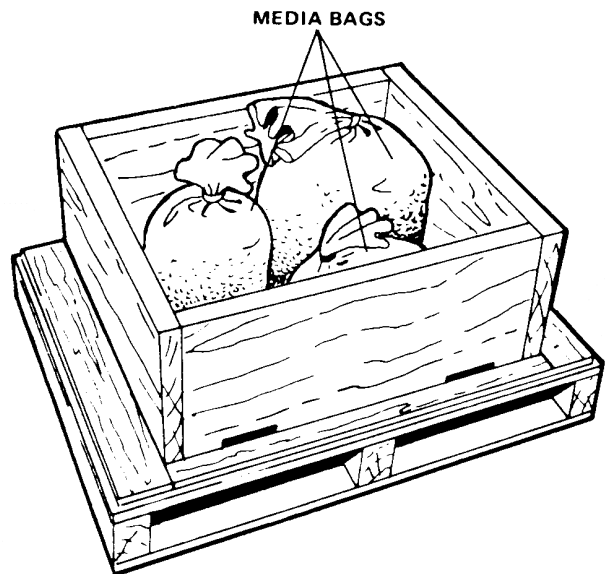

Figure 2-2. Location of Media Bags (Models BB2016 and BB1224)

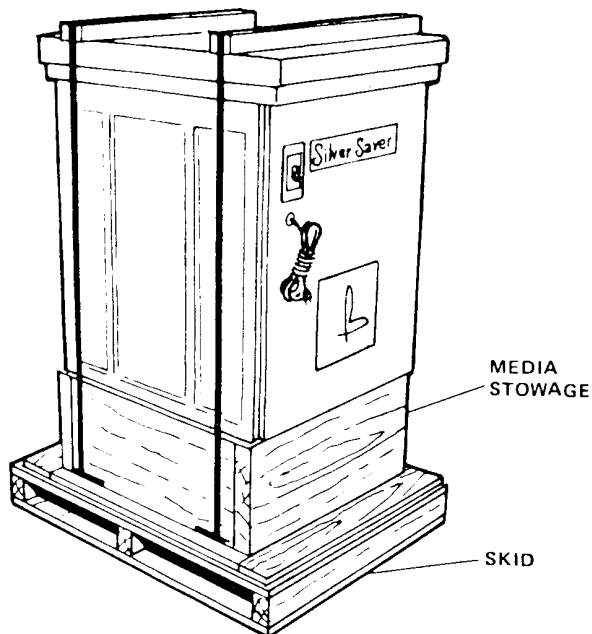

Figure 2-1. Model BB2016 with Shipping Carton Removed

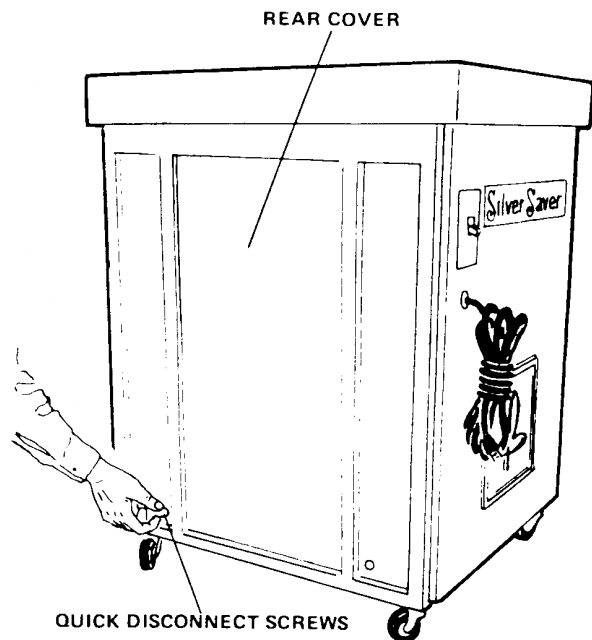

Figure 2-3. Removing Rear Cover (Model BB2016)

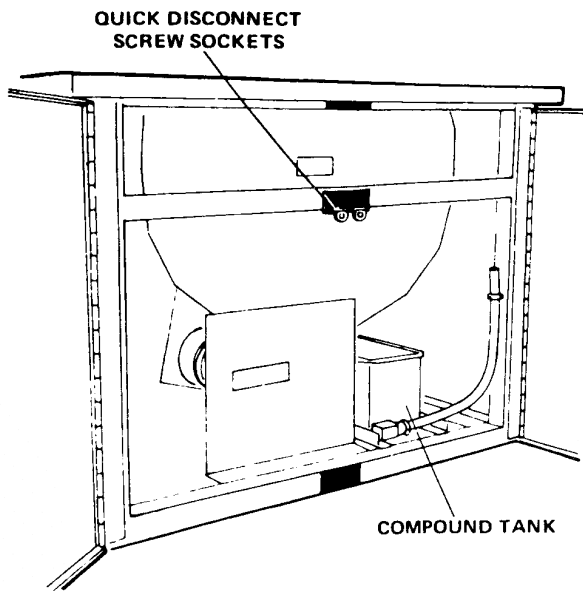

Figure 2-4. Model BB1224 with Front Doors Open

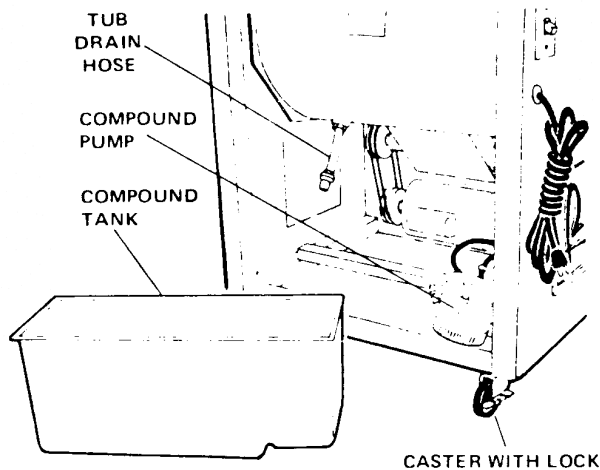

Figure 2-5. Compound Tank Removed (Model 2016)

2-2. INSTALLATION

1. **MODELS BB914 and BB2016.** Lay unit on its side on some of the foam packaging (to prevent scratching the finish) and install casters to bottom of unit. (See fig. 2-6.)

NOTE: One of the casters has a brake (large wing type nut on side of wheel). The most convenient location for the brake caster is the corner directly under the motor starting switch. (See fig. 2-5.)

MODEL BB1224. Place unit in desired operating location (near floor drain if possible). Level machine by loosening jam nut on adjustable feet and screwing feet in or out until unit is level. (See fig. 2-7.)

2. Be sure that compression springs are positioned correctly between upper and lower bumpers. (See fig. 2-8.)

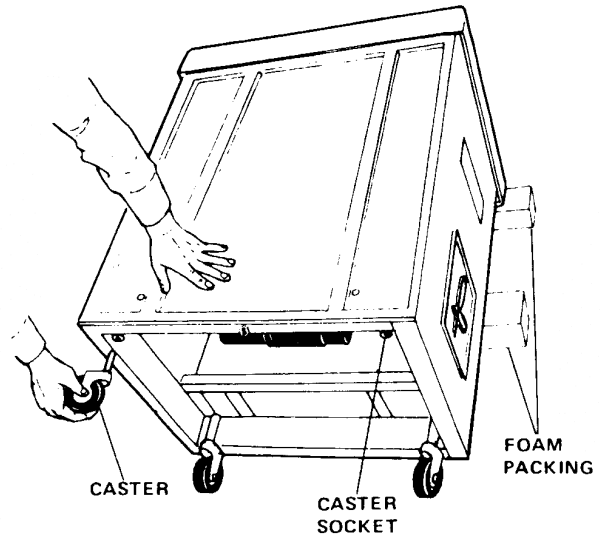

Figure 2-6. Installing Casters (Model BB2016)

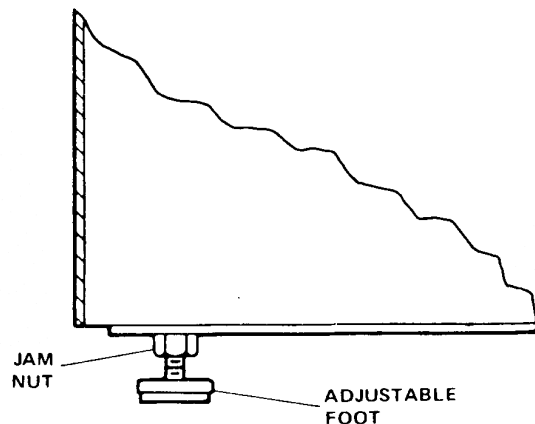

Figure 2-7. Adjustable Foot (Model BB1224)

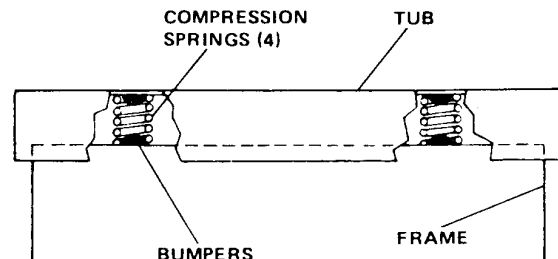

Figure 2-8. Compression Springs Properly Positioned

3. Check the following to make sure nothing has come loose during shipment:
 - A. Drain hose assembly attached to tub.
 - B. Compound hose connected to compound pump and tub.
 - C. Cords, hoses clear of motor belts.
4. Check Motor O-ring belts for correct installation and tension (see fig. 2-9). If belt deflection is not approximately 1/2 inch, adjust as described in MOTOR BELT REPLACEMENT AND ADJUSTMENT (paragraph 4-6).
5. Uncoil motor cable and place on floor next to unit.
6. Install compound tank in unit and place compound pump in recess in bottom of tank. (See fig. 2-10.)
7. Place end of tub drain hose in compound tank.
8. Clean inside of media tub with a cloth dampened in menthal alcohol.

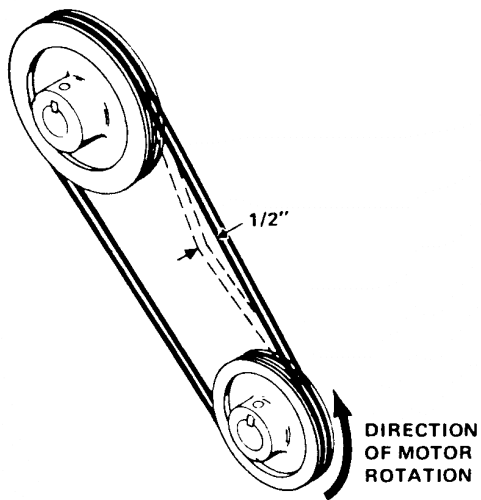

Figure 2-9. Checking Belt Tension

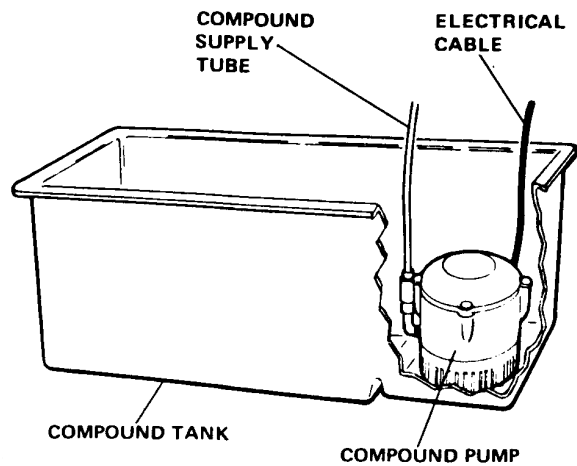

Figure 2-10. Compound Pump Installed In Tank

9. Open bag(s) and empty media into tub (approximately two level inches below compound inlet to tub). (See fig. 2-11.)
10. If unit is to be put into service immediately, refer to operating instructions. If unit is not to be put into service immediately, replace cover.

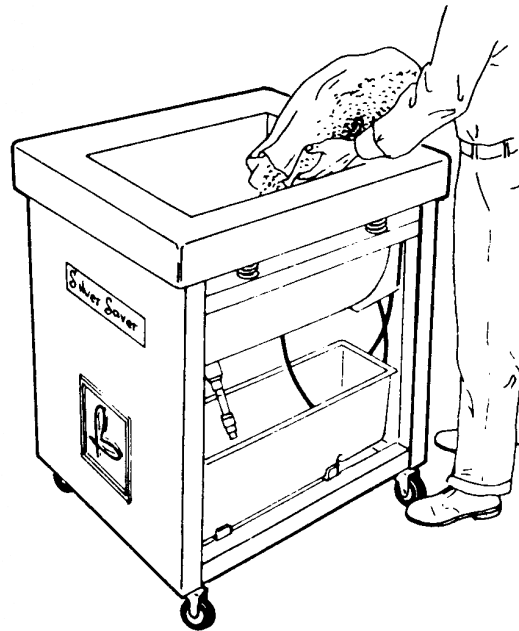

Figure 2-11. Emptying Media Bags Into Tub

SECTION 3 OPERATION

3-1. GENERAL

Before putting unit in operation, be sure all steps outlined in installation instructions have been covered.

NOTE: On initial start-up, it is desirable to flush media before initial use. This is accomplished by going thru steps described in paragraph 3-2 and running unit for approximately 1/2 hour, then draining the unit by following steps described in paragraph 3-4.

IMPORTANT

USE ONLY BLAKESLEE SPECIAL COMPOUND. USE OF OTHER COMPOUND MAY GIVE INCOMPLETE OR UNSATISFACTORY RESULTS. IN SOME CASES DAMAGE TO FINE SILVER COULD OCCUR.

UNDER NO CIRCUMSTANCES SHOULD ITEMS BE PLACED OR SOAKED IN DETAR-NISHING SOLUTION BEFORE BEING PLACED IN BURNISHER.

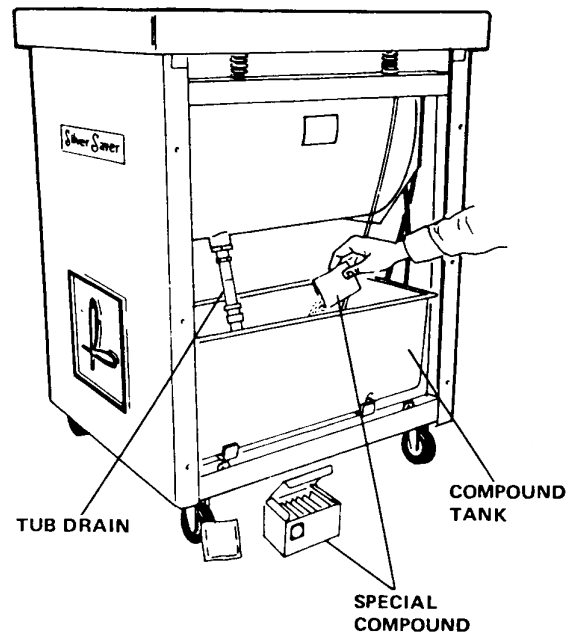

Figure 3-1. Adding Special Blakeslee Compound to Tank (Models 914 & 2016)

3-2. PREPARING COMPOUND SOLUTION (See fig. 3-1.)

1. **MODEL BB914.** Remove rear cover and add one oz. of compound to compound tank.
MODEL BB2016. Remove rear cover and add two oz. of compound to compound tank.
MODEL BB1224. Open front door and add two oz. of compound to compound tank.
2. Be sure end of tub drain hose is in compound tank and external drain hose is held in vertical position by the clip (BB1224 only).
3. Fill compound tank with water to full line (approximately 1-1/2 inch from top of tank).

3-3. OPERATION

1. **MODELS BB914 and BB2016.** Replace rear cover. Place unit in desired operating position and lock brake on caster located under ON-OFF switch.

2. Plug power supply cord into any convenient 115V outlet.

NOTE: Model BB914 requires 6 amp 115V circuit. Models BB2016 and BB1224 require 12 amp 115V circuit.

3. **MODEL BB914 and EARLY MODELS BB2016.** Turn unit on. Motor and compound pump will continue to run as long as switch is in the ON position.

MODEL BB1224 and LATE MODELS BB2016. Turn unit on. Compound pump will run for approximately two minutes then stop automatically. This charge is adequate for 6 hours of operation under normal operating conditions.

NOTE: If unit is turned off for any reason, wait 10 minutes before restarting.

4. Deposit washed items in Burnisher tub.

5. **MODEL BB914** will hold approximately 144 pieces of mixed flatware.

MODELS BB2016 and BB1224 will hold approximately 576 pieces (4 gross) of mixed flatware.

Burnishing a large amount of similar items (all knives, all forks, etc.) at one time is not recommended. Normal burnishing time is 10 minutes. Naturally this will depend on the condition of the ware. Items that have not been burnished for a long period will require more time. A weekly burnishing program will decrease the amount of burnishing time and keep all items looking like new.

NOTE: Items need not be detarnished. If you choose to detarnish, items **MUST** be run through dishwasher again before being placed in Burnisher (all items must be dishwasher clean before processing in Burnisher System).

6. Condition of flatware can be checked while the unit is in operation by observing the items as they rotate in the tub or they can be removed for closer visual inspection.
7. After desired burnishing results have been obtained, remove all items from tub. It is best to remove items from the machine while it is in operation.

NOTE: Do not remove the media (porcelain ceramic balls).

8. Burnished items must then be processed through your dishwashing system in the normal fashion.
9. If more items are to be burnished, repeat steps 4 thru 8.

3-4. DRAINING AND CLEANING THE UNIT

1. If Burnisher will not be used for the remainder of the day, turn off the switch and allow system to drain for a few minutes.

2. **MODELS BB914 and BB2016.** Remove rear cover. Remove compound tank from unit and discard compound solution. Clean tank with fresh water and reinstall in unit.

MODEL BB1224. Open doors and drain compound solution by removing external drain hose from clip and allowing solution to drain into a suitable receptacle or floor drain. (See fig. 3-2.) Flush and clean compound tank with fresh water.

NOTE: Compound must be replaced daily for best results.

3. No cleaning of media is necessary.

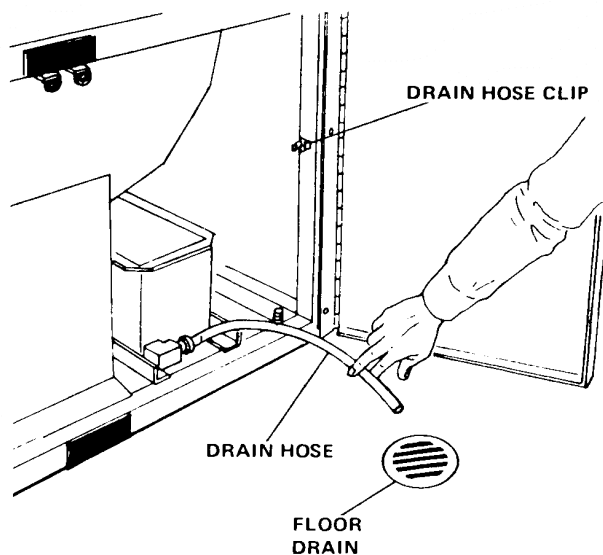

Figure 3-2. Draining Compound Tank (Model BB1224)

SECTION 4 MAINTENANCE

4-1. DAILY

1. Empty and clean compound tank using fresh water and soap.
2. Clean inside and outside of unit with a soft damp cloth. Stainless steel components should be cleaned with stainless steel cleaner and polish.
3. Check to be sure screen in media tub drain is clear of foreign objects. On later model BB2016 and BB1224 Burnishers this screen is located on the end of the drain hose inside the faucet aerator. Remove the aerator and clear or dislodge foreign objects using a wooden toothpick or similar item. (See fig 4-1.)

NOTE: Grasping the tubing tightly or bending the tubing up will prevent any media from falling out when the aerator is removed. (See fig 4-2.) A small cork or rubber stopper can then be inserted in the coupling until the aerator is reinstalled.

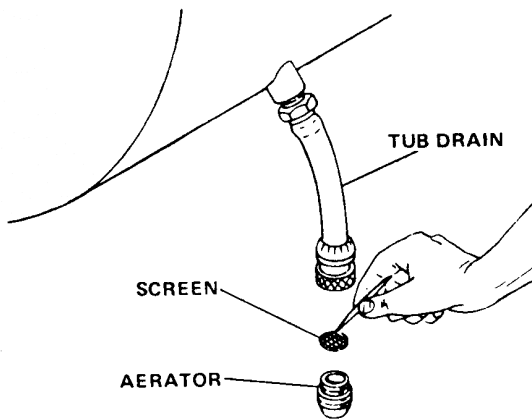

Figure 4-1. Cleaning Tub Drain Screen

4-2. MONTHLY

Check condition of motor belts and hoses. Replace as necessary. See MOTOR BELT REPLACEMENT AND ADJUSTMENT (paragraph 4-6).

4-3. BI-MONTHLY

Lubricate both vibrator bearings through grease fittings provided on flanged bearing assy. Use good grade (E.P.O.) of bearing grease.

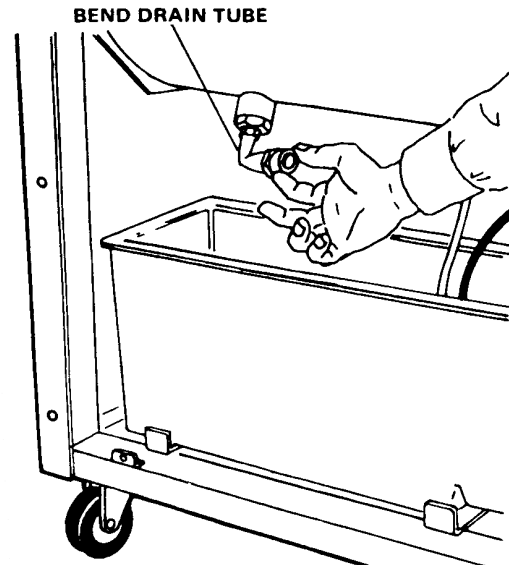

Figure 4-2. Grasping Drain Tube to Prevent Media from Falling Out

4-4. REPLACING TUB DRAIN SCREEN (Early Models)

On model BB914 and older models BB2016 and BB1224 the tub drain screen is located inside the media tub in the tub drain inlet. The redesigned hose assy. can be retrofitted on models BB2016 and BB1224 (except some very early models) by simply prying the old screen out of the tub drain inlet (see fig 4-3) and installing the new drain hose assy. (part no. W-0-95016).

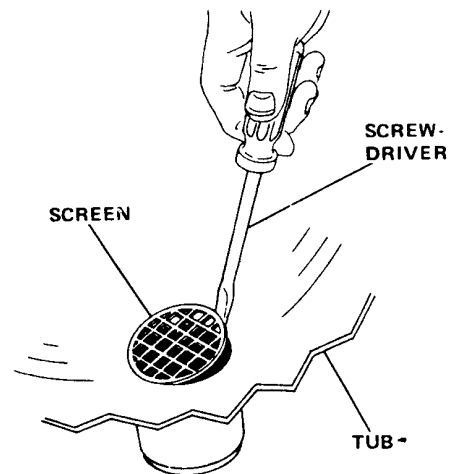

Figure 4-3. Removing Tub Drain Screen From Early Models BB2016 and BB1224

4.5. MEDIA REPLACEMENT

The best burnishing results are obtained when both 1/8" and 1/4" porcelain-ceramic media (balls) are mixed. Proper mixture is 3 parts 1/8" media (white color) to one part 1/4" media (blue color) by weight.

The burnishing media supplied with your machine has been pre-mixed as described above. When replacement media is ordered, it also will be mixed as shown above.

4-6. MOTOR BELT REPLACEMENT AND ADJUSTMENT

MODELS BB914 and BB2016. Remove rear covers by turning quick disconnect screws 1/4 turn counterclockwise.

MODEL BB1224. Open front doors by turning quick disconnect screws 1/4 turn counterclockwise.

CAUTION

MAKE SURE SWITCH IS OFF AND POWER CORD IS DISCONNECTED FROM WALL OUTLET.

ALL MODELS USING DOUBLE "O-RING" TYPE BELTS.

1. Because these belts have more "stretch" than ordinary "V" belts they can be removed and replaced without loosening the motor mounts. Simply pull the belt to the top of the pulley groove and rotate pulley by hand until belt pops off. These belts should be replaced in sets.
2. Install new belts making sure belts are seated properly in grooves and are not twisted.
3. Check belt tension for approximately 1/2-inch deflection when moderate pressure is applied to belts as shown in fig. 2-9. If adjustment is required, loosen motor mount bolts and slide motor until proper tension is obtained.

NOTE: Media tub should be filled with proper amount of media before checking or adjusting belt tension.

ALL MODELS USING "V" BELT DRIVE

1. Removal and replacement is the same as for O-ring belts except that the motor mount bolts must be loosened in order to remove or replace the belt.
2. Adjustment is the same as O-ring belts.

4-7. CONVERTING "V" BELT DRIVE TO "O-RING" DRIVE

MODEL BB914. Parts needed for conversion are as follows:

Double groove driven pulley W-0-20456
Double groove drive pulley W-0-20458
Special "O-ring" belt (2 required) . . . W-0-20459
1/2 hp, 3450 rpm motor W-0-95057

CAUTION

MAKE SURE SWITCH IS OFF AND POWER CORD IS DISCONNECTED FROM WALL OUTLET.

1. Disconnect electrical wires from motor.
2. Remove bolts securing motor to motor mount plate.
3. Remove "V" belt and motor.
4. Remove driven pulley from eccentric shaft.
5. Install new 3450 rpm motor with the same bolts used on the old motor.
6. Connect electrical wires to motor terminals.
7. Install driven pulley (large diameter) on eccentric shaft with setscrew side of hub facing out.
8. Install drive pulley (small diameter) on motor shaft with setscrew side of hub facing out.
9. Using a straight edge or ruler, adjust the pulleys so they are exactly in line (see fig. 4-4) then tighten setscrews.
10. Install new belts as described in MOTOR BELT REPLACEMENT AND ADJUSTMENT (paragraph 4-6).

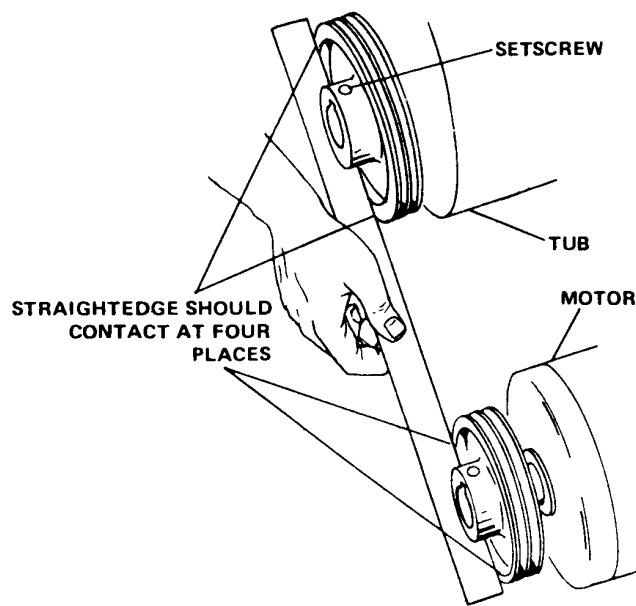

Figure 4-4. Checking Pulley Alignment

MODEL BB2016. Parts needed for conversion are as follows:

- Double groove driven pulley W-0-20456
- Double groove drive pulley W-0-20457
- Special "O-ring" belt (2 required) . . . W-0-20459
- 1 hp, 3450 rpm motor W-0-95058

CAUTION

MAKE SURE SWITCH IS OFF AND POWER CORD IS DISCONNECTED FROM WALL OUTLET.

1. Disconnect electrical wires from motor.
2. Remove the entire motor and motor mount assy. (see fig. 5-3). These parts will not be reused.
3. Remove motor mount plate. Layout and drill two new holes in the plate as shown in fig. 4-5.
4. Reinstall motor mount plate.
5. Install new 3450 rpm motor.
6. Connect electrical wires to motor terminals.
7. Install drive pulley (small diameter) on motor shaft with setscrew side of hub facing out.
8. Remove old driven pulley from eccentric shaft and replace with new double groove pulley (large diameter). Setscrew side of hub should face out.

9. Using a straightedge or ruler, adjust the pulleys so they are exactly in line (see fig. 4-4) then tighten setscrews.
10. Install new belts as described in MOTOR BELT REPLACEMENT AND ADJUSTMENT (paragraph 4-6).

4-8. ECCENTRIC BEARING REPLACEMENT

1. Remove front cover, rear cover, and guards as necessary to gain access to both flange bearings.
2. Remove drive belts.
3. Remove driven pulley from eccentric shaft.
4. Model BB914 refer to insert in fig. 5-1. Models BB2016 and BB1224 refer to fig. 5-4. Remove three bearing bolts, nuts, and lockwashers.
5. Remove flange bearings and eccentric shaft assy. from housing.

NOTE: If the unit is still equipped with the old style 2 piece lead weight it should be converted at this time to the one piece steel weight. Refer to parts list for parts required for conversion.

6. Reinstall eccentric shaft assy. in housing.
7. Install flange bearings on eccentric shaft and line up bolt holes with grease fittings positioned for easiest access for servicing.
8. Install and tighten three flange bolts, nuts and washers.
9. Install pulley on eccentric shaft and line up pulleys as shown in fig. 4-4. Tighten setscrew.
10. Install belts and check for proper tension as described in MOTOR REPLACEMENT AND ADJUSTMENT (paragraph 4-6).
11. Replace all guards and covers.
12. After unit has run approximately 30 minutes, lubricate both flange bearings through grease fittings on housings.

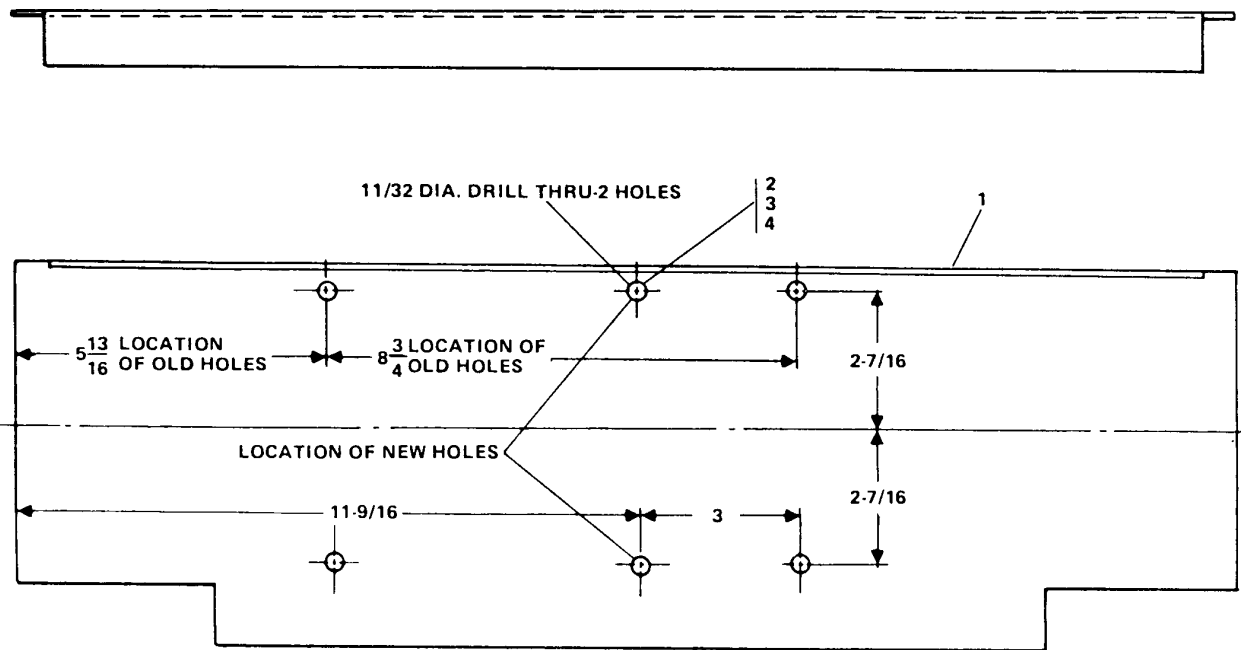

- NOTE:
1. DRILL 2 HOLES 11/32 DIA. TO INSTALL ITEMS 2, 3 & 4 FOR BOLTING MOTOR TO MOUNT PLATE.
 2. USE OLD 5/16 BOLTS FOR CONVERSION.

4	A/R		5/16 WASHER
3	2		5/16-18 HEX NUT
2	4		5/16-18 x 1/2 LG H.H.C.S. PLATED
1	1		11 GA C.R. STL 7-15/16 x 22-3/4
ITEM NO.	QTY.	PART NO.	DESCRIPTION

Figure 4-5. Layout Drawing for Modifying BB2016 Motor Mount Plate

4-9. MEDIA TUB REPLACEMENT

CAUTION

MAKE SURE SWITCH IS OFF AND POWER CORD IS DISCONNECTED FROM WALL OUTLET:

1. Remove all media from tub.
2. Remove drive belts.
3. Disconnect compound supply tube from compound pump.
4. Lift media tub out of unit.
5. Transfer eccentric assy. from old tub to new tub. Refer to ECCENTRIC BEARING REPLACEMENT (paragraph 4-8).
6. Transfer rubber bumpers, compound supply tube and tub drain hose assy. to new tub.
7. Insert new tub into unit making sure springs are properly positioned (see fig 2-8.)
8. Reconnect compound supply tube to compound pump.
9. Reinstall drive belts.
10. Remove any foreign objects from tub and wash tub lining with methol alcohol.
11. Fill tub to proper level with media.

4-10. COMPOUND PUMP

The compound pump is the same for all units, however its operation varies between units. On model BB914 and early model BB2016 the pump continues to run as long as the switch is on. On model BB1224 and later model BB2016 a timing relay is used to automatically turn the pump off 2 minutes after the unit is started. This 2 minute charge is sufficient for approximately 6 hours or until the unit is turned off. Once the unit is turned off it must remain off for 10 minutes to allow the compound solution to drain into the compound tank.

The compound pump is a sealed unit and requires no service or maintenance. If the pump fails to operate it can easily be replaced by disconnecting the compound supply tube and wires from the switch or timing relay.

4-11. DRIVE MOTOR ROTATION

The electric drive motor should rotate in a counterclockwise direction (see fig 2-9). The direction of rotation can be

reversed by changing the internal wiring of the motor. Instructions are usually provided on the motor data plate. When the motor is rotating properly the media will be pitched as shown in fig 4-6.

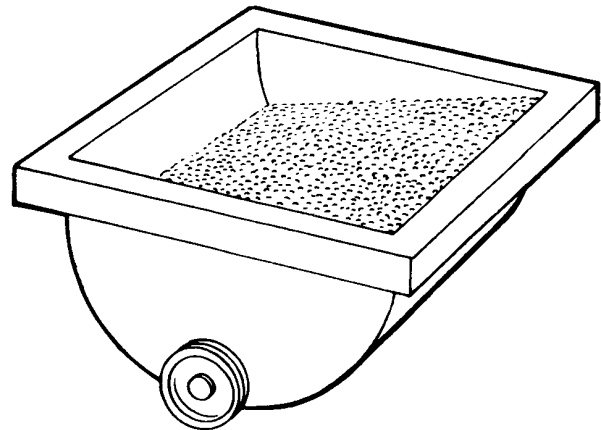

Figure 4-6. Pitch of Media as Viewed from Pulley Side of Tub

4-12. WIRING DIAGRAMS AND SCHEMATICS

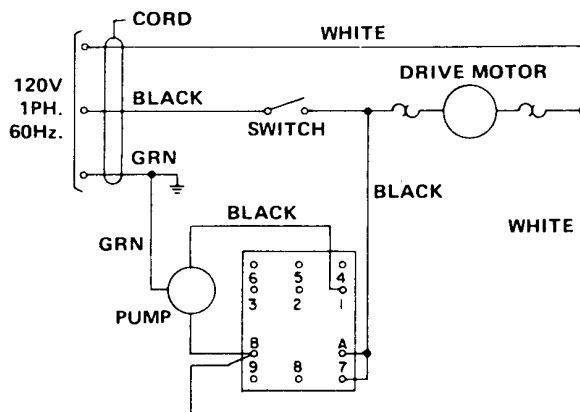

Figure 4-7. Wiring Diagram, Model BB1224 and Late Model BB2016

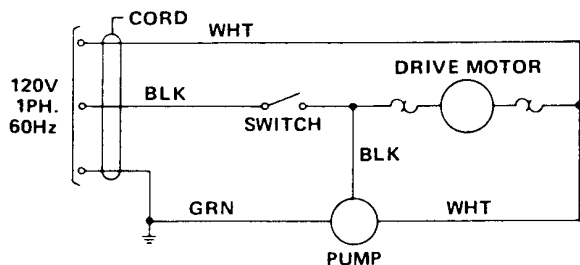

Figure 4-8. Wiring Diagram, Model BB914 and Early Model BB2016

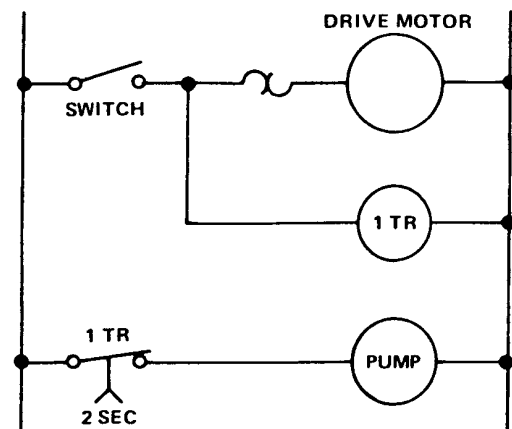

Figure 4-9. Schematic, Model BB1224 and Late Model BB2016

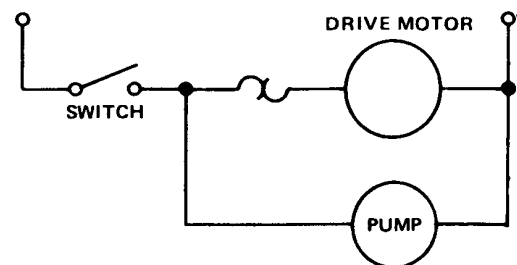

Figure 4-10. Schematic, Model BB914 and Early Model BB2016

4-13. TROUBLESHOOTING

PROBLEM	CAUSE	REMEDY
Unit fails to operate.	Unit not plugged in. Blown fuse or circuit breaker. Defective switch. Broken wire in power supply cord.	Plug in power cord. Replace fuse or reset circuit breaker. Replace switch. Repair or replace.
Drive motor overheats.	Eccentric bearings seizing due to lack of lubrication. Low supply voltage to motor. Internal defect in motor.	Lubricate or replace bearings as necessary. Check voltage at wall outlet. Possibly too much load on that circuit. Reduce load on circuit or use different circuit. Have motor tested by qualified technician.
Excessive noise.	Media tub spring(s) broken or out of position. Eccentric bearings worn. Pulleys loose on motor or eccentric shaft. Eccentric bearings need lubrication. Drive belts worn or frayed. Loose covers or panels.	Replace spring or reposition. See fig. 2-8. Replace eccentric bearings. Tighten setscrew in pulley hub. Lubricate bearings through grease fittings. Replace belts. Tighten screws.
Media tub fails to maintain proper level of compound solution.	Compound pump inlet plugged. Compound pump inoperative. Timing relay improperly adjusted or inoperative. Late Model 2016 and Model 1224 only. Drive motor rotating in wrong direction (new unit or new motor only).	Clean pump inlet. Replace pump. Readjust or replace as necessary. Check that motor rotates counterclockwise when facing front of pulley. Have wiring checked by qualified technician.

SECTION 5 ILLUSTRATED PARTS LIST

To expedite delivery, all parts must be ordered by name and number listed in this parts list.

All orders must include Serial Number of the machine. Place your order with your local Blakeslee Parts Distributor or Service Agency. Their name and address can be found in the Service Agency Booklet which accompanies this manual. If you need further assistance, contact:

BLAKESLEE
1844 S. Laramie Avenue
Chicago, Illinois 60804
708-656-0660

REPLACEMENT BURNISHING MEDIA AND CHEMICAL COMPOUND

PART NO.	DESCRIPTION
W-0-18021-A W-0-18026-A	<p style="text-align: center;">BURNISHING MEDIA</p> <p>Consisting of 1/8" x 1/4" diameter balls mixed, 3 parts 1/8" balls and 1 part 1/4" balls BY WEIGHT.</p> <p>8 carton case of 5 lb. cartons 1 - 40 lb. carton</p>
W-0-18020	<p style="text-align: center;">CHEMICAL COMPOUND</p> <p>Case of 4 Gallons</p>

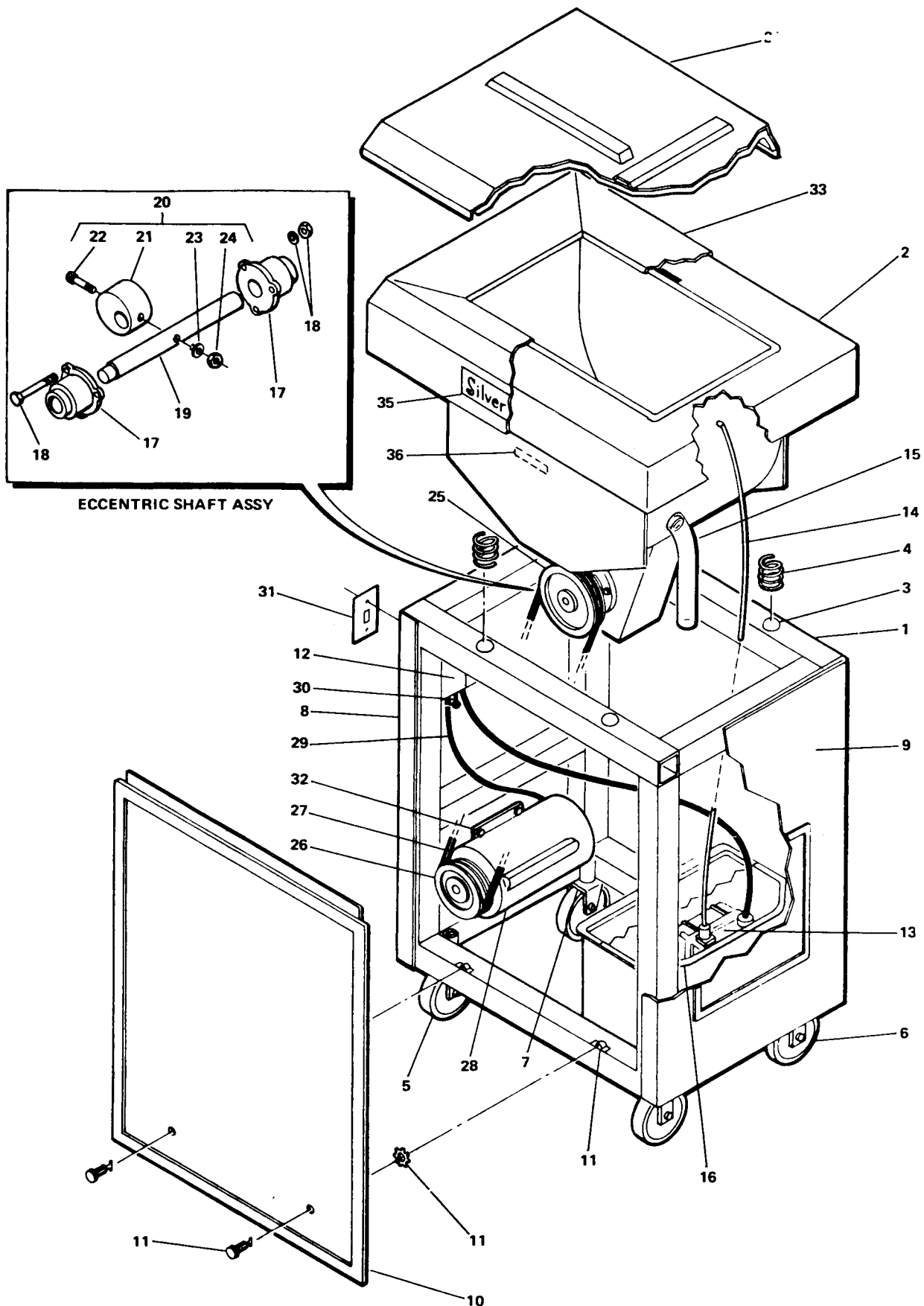

Figure 5-1. Model BB914 Main Assembly

FIGURE 5-1. MODEL BB914 MAIN ASSEMBLY

ITEM NO.	PART NO.	DESCRIPTION	QTY. REQD.
1	W-0-17916	FRAME ASSY, w/electric box and casters, epoxy painted	1
2	W-0-17917	TUB WELDMENT, Complete w/urethane lining and epoxy paint	1
3	W-0-17919	RUBBER BUMPER	8
4	W-0-17920	SPRING, Painted, set of 4	1
5	W-0-17921	CASTER, w/brake, w/o bracket	1
6	W-0-18017	CASTER w/brake, w/ bracket	1
7	W-0-17922	BRACKET, For casters, unpainted	1
8	W-0-17923	ABS GUARD, Left side switch opening, w/double coated tape and rivets	2
9	W-0-17924	ABS GUARD, Right side w/tape and rivets	1
10	W-0-17925	ABS GUARD Front and/or rear, w/o fasteners	1
11	W-0-17926	FASTNER KIT, Quick disconnect, for front and rear guards, 3 piece Assy.	1
12	W-0-17942	TOGGLE SWITCH (Older machines)	1
12A	W-0-77589	STARTER SWITCH	1
12B	W-0-77590	HEAT ELEMENT	1
13	W-0-17929	COMPOUND PUMP 110V 60 CYCLE	1
13A	W-0-95556	COMPOUND PUMP 230V 50/60 CYCLE	
14	W-0-17930	HOSE ASSY, Compound supply, ¼"-28 x 1 ½" long	1
15	W-0-95016	DRAIN HOSE ASSY, Complete with 5/8" hose	1
16	W-0-17932	COMPOUND TANK	1
17	W-0-17933	FLANGED BEARING ASSY, Painted	2
18	W-0-17935	BEARING BOLT KIT	1
19	W-0-17934	SHAFT	1
20	W-0-20766	ECCENTRIC WEIGHT ASSY, Consists of:	1
21	W-0-20765	• ECCENTRIC WEIGHT	1
22	W-0-20460	• SCREW, Socket head, ¼"-28 x 1 ½: long	1
23	W-0-07023	• LOCKWASHER, ¼"	1
24	W-0-20313	• NUT, ¼"	1
25	W-0-20456	PULLEY, Driven, double groove, serial no. 77-001 and up	1
25A	W-0-17936	PULLEY, Driven, single groove, serial no. 77-000 and below	1
26	W-0-20458	PULLEY, Drive, double groove, serial no. 77-001 and up	1
26A	W-0-17938	PULLEY, Drive, single groove, serial no. 77-000 and below	1
27	W-0-20459	BELT, "O"-ring type, serial no. 77-001 and up	2
27A	W-0-16907	BELT, "V" type, serial no. 77-000 and below	1
28	W-0-95057	MOTOR, ½ hp, 3450 rpm, 110/220 V, 1 phase, 60 cycle	1
28A	P-1-05280	MOTOR, 1/3 hp, 1725 rpm, 110/220 V, 1 phase, 60 cycle	1
28C	W-0-76306	MOTOR, ¾ hp, 3450 rpm, 110/220 V, 1 phase, 60 cycle	1
29	W-0-17940	CABLE, Electrical w/connectors, motor to switch	1
30	W-0-17941	CABLE, Electrical, w/connectors power supply	1
31	W-0-17943	COVER s/s toggle switch	1
32	NLA		
33	W-0-17927	MEDIA RETURN TOP DECK, w/decals and chrome fastener	1
34	W-0-17928	TUB COVER, Can be used only with media return top deck	1
35	W-0-18618	DECAL, Silver Saver	1
36	W-0-20340	DECAL, Serial no.	1

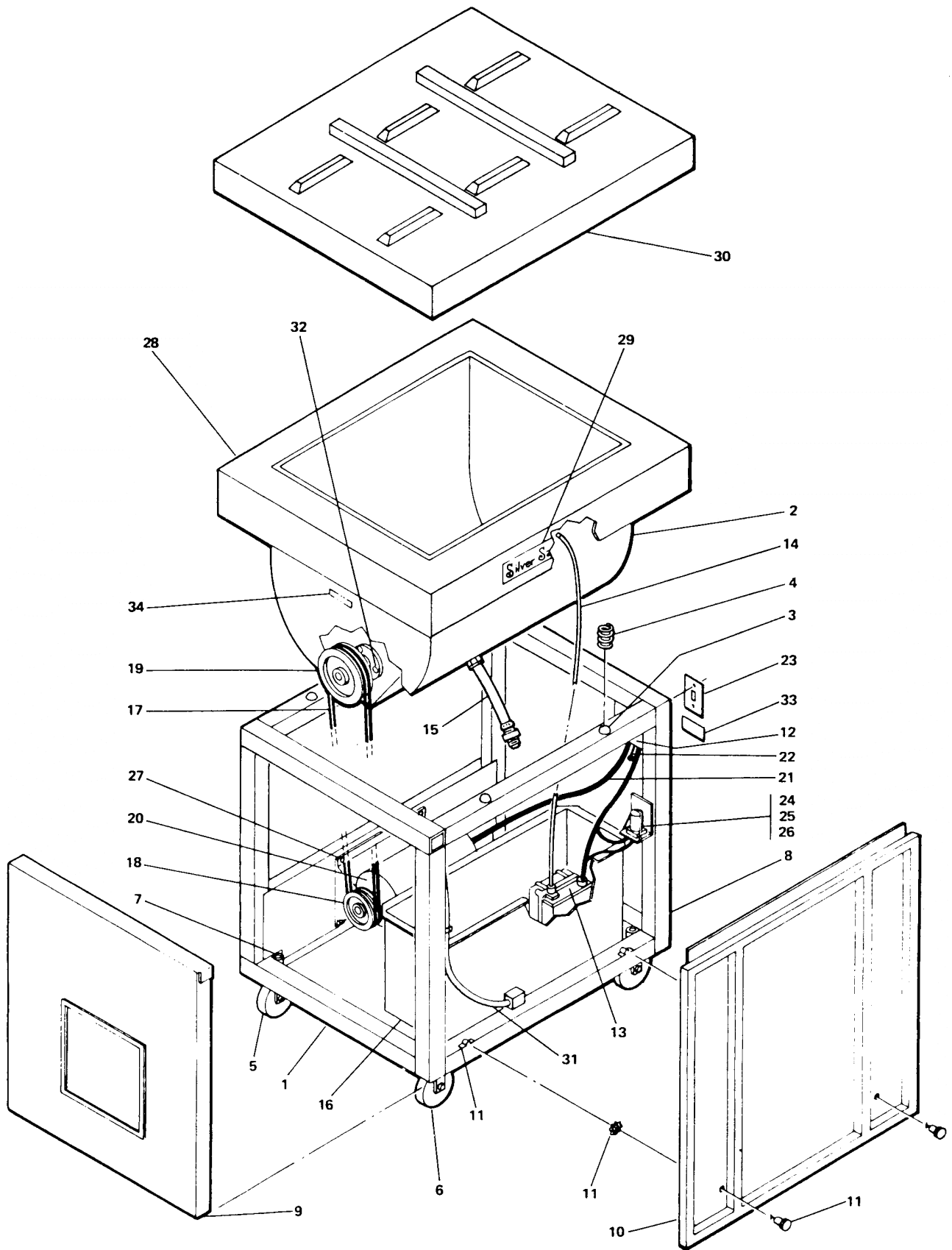

Figure 5-2. Model BB2016 Main Assembly

FIGURE 5-2. MODEL BB2016 MAIN ASSEMBLY

ITEM NO.	PART NO.	BB2016 DESCRIPTION	QTY. REQD.
1	W-0-18675	FRAME ASSY, w/electric box and casters, epoxy painted	1
2	W-0-17917	TUB WELDMENT, Complete w/urethane lining and epoxy paint	1
3	W-0-17919	RUBBER BUMPER	8
4	W-0-17920	SPRING, Painted, set of 4	1
5	W-0-17921	CASTER, w/brake, w/o bracket	1
6	W-0-18017	CASTER w/brake, w/ bracket	1
7	W-0-17922	BRACKET, For casters, unpainted	1
8	W-0-18678	COVER, Left side w/switch opening, included double sided tape and screws	2
9	W-0-18678	COVER, Right side includes double sided tape and screws	1
10	W-0-18680	COVER, Front and/or rear	1
11	W-0-17926	FASTNER KIT, Quick disconnect, for front and rear guards, 3 piece Assy.	4
12	W-0-17942	TOGGLE SWITCH (Older machines)	1
12A	W-0-77589	STARTER SWITCH	1
12B	W-0-77590	HEAT ELEMENT	1
13	W-0-17929	COMPOUND PUMP 110V 60 CYCLE	1
13A	W-0-95556	COMPOUND PUMP 230V 50/60 CYCLE	
14	W-0-17930	HOSE ASSY, Compound supply, ¼"-28 x 1 ½" long	1
15	W-0-95016	DRAIN HOSE ASSY, Consists of the following parts	1
		• FAUCET AERATOR	1
		• ADAPTER, Hose connector to aerator	1
		• HOSE CONNECTOR, ½" male	1
		• POLYVINYL TUBING, 5/8" x ½" x 6 ½" long	1
	W-0-20325	• COUPLING, Reusable	1
16	W-0- 18681	COMPOUND TANK	1
17	W-0-20459	BELT, "O"-ring type, serial no. 77-001 and up	2
17A	W-0-16907	BELT, "V" type, serial no. 77-000 and below	1
18	W-0-20456	PULLEY, Driven, double groove, serial no.20S-77-001 and up	1
18A	W-0-17936	PULLEY, Driven, single groove, serial no. 20S-77-000 and below	1
19	W-0-20458	PULLEY, Drive, double groove, serial no. 20S-77-001 and up	1
19A	W-0-17938	PULLEY, Drive, single groove, serial no. 20S-77-000 and below	1
20	W-0-95058	MOTOR, 1 hp, 3450 rpm, 110/220 V, 1 phase, 60 cycle	1
20A	W-0-18684	MOTOR, ¾ hp, 1725 rpm, 110/220 V, 1 phase, 60 cycle	1
21	W-0-17940	CABLE, Electrical w/connectors, motor to switch	1
22	W-0-17941	CABLE, Electrical, w/connectors power supply	1
23	W-0-17943	COVER, s/s toggle switch	1
24	W-0-20336	RELAY, Timing, (late production models) 110V 60cycle	1
24A	W-0-95557	RELAY, Timing, (late production models) 220V 50cycle (export only)	1
25	W-0-20335	SOCKET, Timing, (late production models)	1
26	W-0-15971	TIE WRAP, Timing, (late production models)	1
27	NLA		
28	W-0-18687	TUB EXTENSION	1
29	W-0-18618	DECAL, Silver Saver	1
30	W-0-18688	TUB COVER	1
31	W-0-18691	HOSE KIT, Compound tank drain, includes connector and spring clip	1
32	W-0-20338	ECCENTRIC SHAFT ASSY (See fig. 5-4 for details)	1
33	W-0-20338	DECAL	1
34	W-0-20340	DECAL	1

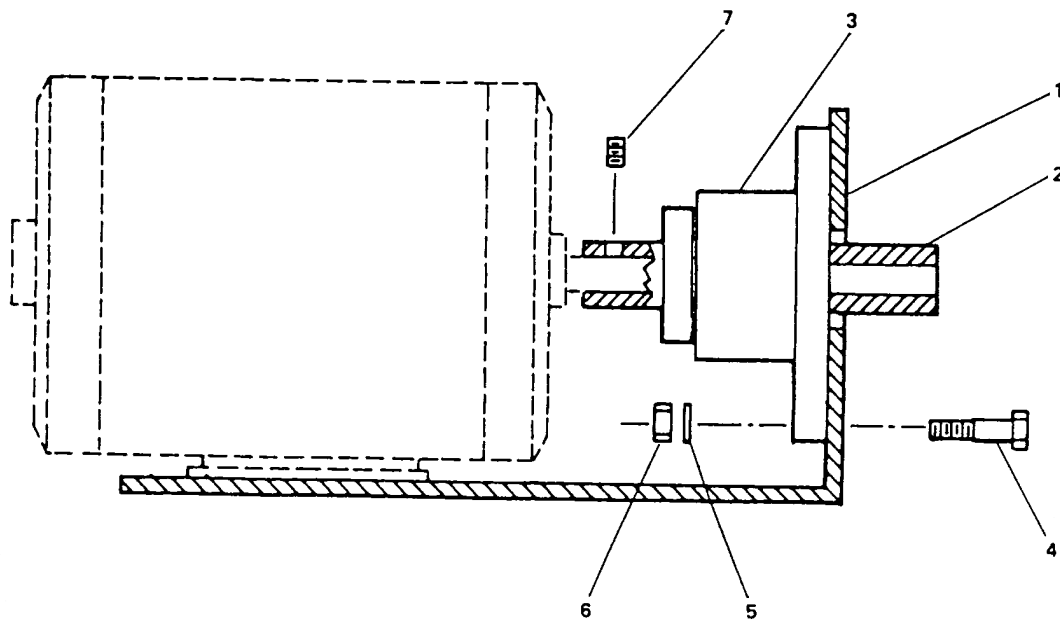

Figure 5-3. Motor Mount Assembly, Model BB2016
(Serial No. 20S-77-000 and Below)

ITEM NO.	PART NO.	DESCRIPTION	QTY. REQD.
1	W-0-18806	SUPPORT, Motor bearing	1
2	W-0-18807	SHAFT, Extension	1
3	W-0-18808	BEARING, Flanged	1
4	W-1-7657	BOLT, Hex head, 3/8-16 x 1-1/4" lg	3
5	W-1-15334	LOCKWASHER, 3/8"	3
6	W-1-7115	NUT, Hex, 3/8"-16	3
7	P-1-17243	SETSCREW, 1/4-10 x 3/8" lg	1

NOTE: These parts are no longer used starting with serial number 20S-77-001 and up. When either the motor or flanged bearing need replacing on older models, the system should be changed to the new style. Refer to Section 4 for instructions on converting to the new system.

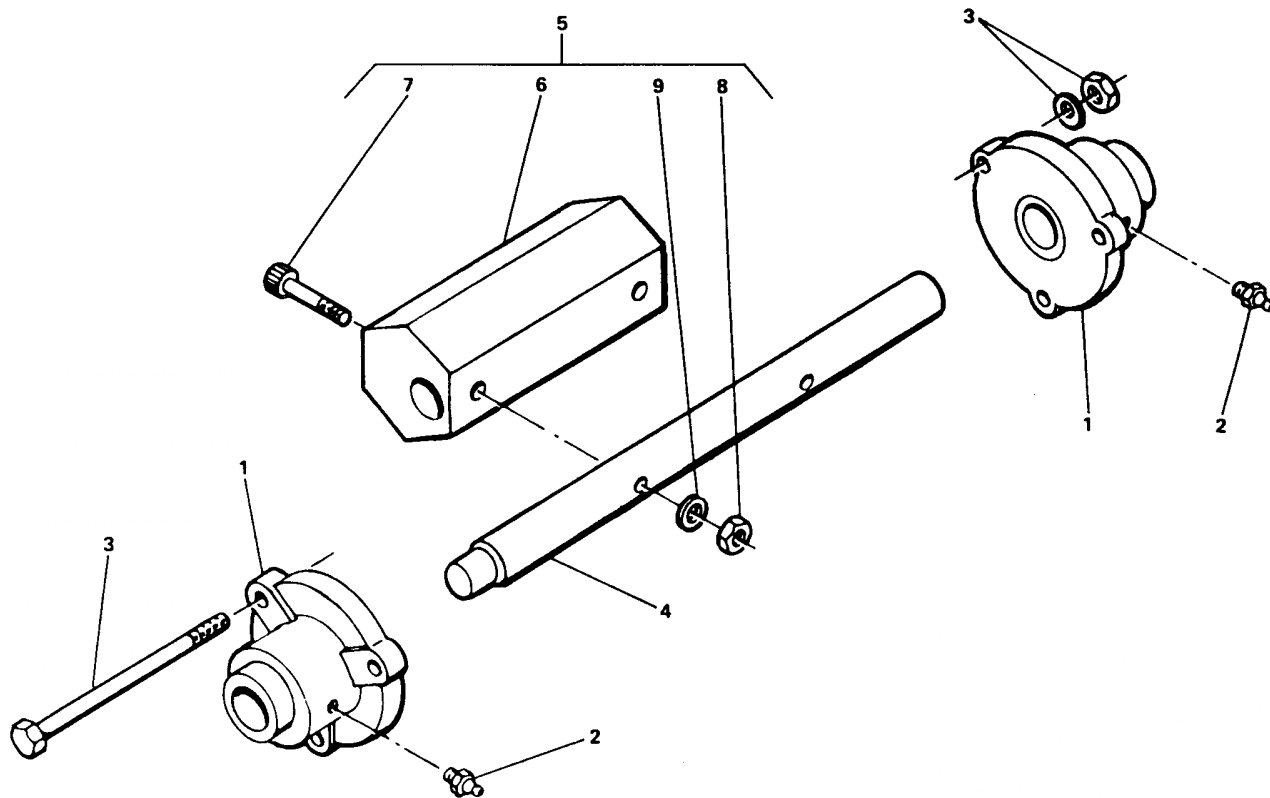

Figure 5-4. Eccentric Shaft Assembly
Models BB2016 and BB1224

ITEM NO.	PART NO.	DESCRIPTION	QTY. REQD.
1	W-0-17933	FLANGED BEARING ASSY	2
2	W-0-20314	GREASE FITTING	2
3	W-0-18683	BEARING BOLT KIT	1
4	W-0-18682	ECCENTRIC SHAFT	1
5	W-0-20767	ECCENTRIC WEIGHT ASSY, Consists of:	1
6	W-0-20432	• ECCENTRIC WEIGHT	1
7	W-0-20460	• SCREW, Socket head, 1/4-28 x 1-1/2" lg	2
8	W-0-20313	• NUT, Hex, 1/4"-28	2
9	W-0-7023	• LOCKWASHER, 1/4"	2

NOTE: When replacing old style 3 piece eccentric weight order item 5, Eccentric Weight Assy.

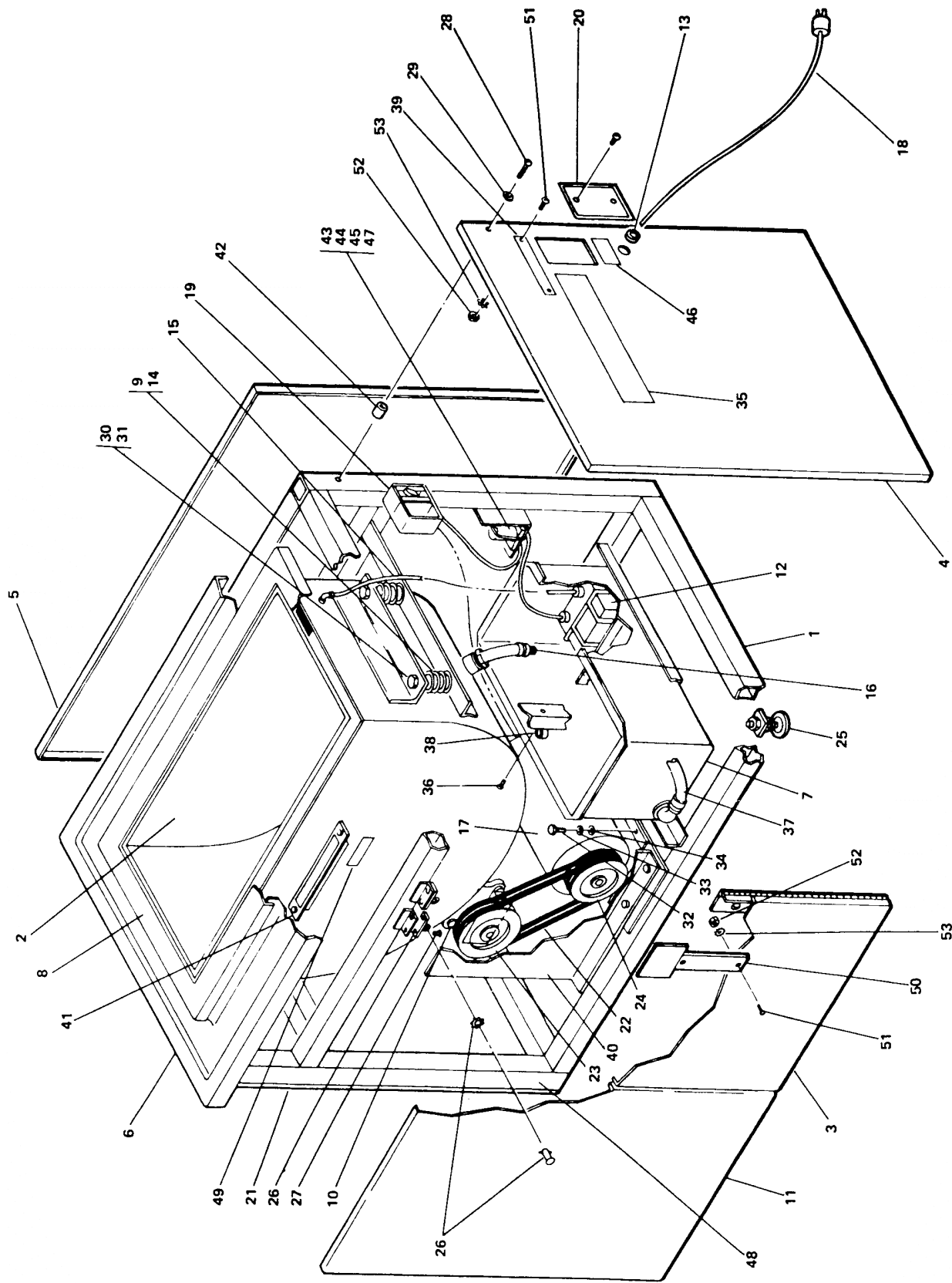

Figure 5-5. Model BB1224 Main Assembly

FIGURE 5-5 MODEL BB1224 MAIN ASSEMBLY

ITEM NO.	PART NO.	DESCRIPTION	QTY. REQD.
1	W-0-18675	FRAME WELDMENT	1
2	W-0-18676	TUB WELDMENT, Complete w/urethane lining and epoxy paint	1
3	W-0-20317	DOOR, Front, RH	
4	W-0-20318	COVER, Side, RH	
5	W-0-20319	COVER, Back	
6	W-0-20320	COVER, Frame Top	
7	W-0-20321	TANK, Compound	
8	W-0-20322	COVER, Tub	
9	W-0-17920	SPRING, Compression	1
10	W-0-20338	ECCENTRIC SHAFT ASSY (See fig. 5-4 for details)	1
11	W-0-20345	DOOR, Front, LH	1
12	W-0-17929	COMPOUND PUMP 110V 60 CYCLE	1
12A	W-0-95556	COMPOUND PUMP 230V 50/60 CYCLE	
13	W-0-20323	GROMMET	1
14	W-0-17919	RUBBER BUMPER	8
15	W-0-17931	HOSE ASSY, Compound supply w/connectors	1
16	W-0-95016	DRAIN HOSE ASSY, Consists of the following parts	1
		• FAUCET AERATOR	1
		• ADAPTER, Hose connector to aerator	1
		• HOSE CONNECTOR, 1/2" male	1
		• POLYVINYL TUBING, 5/8" x 1/2" x 6 1/2" long	1
	W-0-20325	• COUPLING, Reusable	1
17	W-0-95058	MOTOR, 1.5 hp, 3450 rpm, 110/220 V, 1 phase, 60 cycle	
17A	W-0-95555	MOTOR	
18	W-0-17941	CABLE, Electrical, w/connectors power supply	
19	W-0-17942	TOGGLE SWITCH (Older machines)	1
19A	W-0-77589	STARTER SWITCH	1
19B	W-0-77590	HEAT ELEMENT	1
20	W-0-17943	COVER, s/s toggle switch	1
21	W-0-20346	COVER, Side, LH	
22	W-0-20459	BELT, "O"-ring type, serial no. 77-001 and up	
23	W-0-20456	PULLEY, Driven, double groove	
24	W-0-20457	PULLEY, Drive, double groove	
25	W-0-20326	FEET, Level mount	
26	W-0-17926	FASTNER KIT, Quick disconnect, for front and rear guards, 3 piece Assy.	
27	W-0-20327	RIVET, Aluminum	4
28	W-1-05599	SCREW, Rd. hd, s/s, 10-32 x 1-1/2: lg.	36
29	W-1-07285	LOCK WASHER, s/s, no. 10	36
30	W-1-07680	NUT, Hex, no 10-24	8
31	W-1-07647	LOCK WASHER, No. 10	14
32	W-1-07291	SCREW, Cap, hex hd, 5/16-18X1" lg	4
33	W-1-05996	LOCK WASHER, Split, 5/16"	4
34	W1-105587	WASHER, Flat, 5/16"-10	4
35	W-0-18618	DECAL, Silver Saver	1
36	W-0-20328	SCREW, Self tapping washer hd, Rollex, 6/32 x 1/2" lg.	1
37	W-0-20329	TUBING, Polyvinyl, 5/8" OD X 1/2" ID X 30" lg>	1
38	W-0-20330	CLIP, Spring	1
39	W-2-16380	NAMEPLATE, Blakeslee (horizontal)	1
40		GUARD, Drive belt	1
41	W-0-20333	PAN, Frame cover	1
42	W-0-20334	SPACER, Cover	
43	W-0-20335	SOCKET, Timing, (late production models)	1

FIGURE 5-5 MODEL BB1224 MAIN ASSEMBLY (Continued)

44	W-0- 20336	RELAY, Timing, (late production models) 110V 60cycle	1
44A	W-0- 95557	RELAY, Timing, (late production models) 220V 50cycle (export only)	1
45	W-0- 20337	SMITH SHAFT LOCK	
46	W-0-20338	DECAL	1
47	W-0- 15971	TIE WRAP, Timing, (late production models)	1
48	W-0-02339	TAPE, Scotch foam, 16 ft	1
49	W-0-20340	DECAL, Serial no.	1
50	W-2- 16380	NAPEPLATE, Blakeslee (vertical)	1
51	W-1- 07476	SCREW	4
52	W-1- 07104	NUT	4
53	W-1- 08839	LOCKWASHER	4

Blakeslee Authorized Parts & service Distributors and Preferred Service Agents are the focal point for service and are responsible for all warranty/repair work and for maintaining a complete stock of replacement parts.

They have factory-trained servicemen and are kept informed by the factory on the latest servicing procedures.

To receive service and/or parts, call the Blakeslee Distributor nearest you. If you happen to be in an area not covered by a distributor, phone the Blakeslee Service Department in Chicago at 708-656-0660 for the name and location of one of over 300 strategically-located Blakeslee Authorized Service Agencies, which is nearest you.

ALABAMA

Jones McLeod Appliance Co.
1616 Seventh Ave. North
Birmingham, AL 35203
205-251-0159

ARIZONA

Byassee Equipment
1939 E. Washington
Phoenix, AZ 85034
602-252-0402

ARKANSAS

Bromley Parts & Service
10th & Ringo Street
Little Rock, AR 72202
501-374-0281

CALIFORNIA

Acme Pacific Repairs, Inc.
1347 Fulton Place
Fremont, CA 94539
510-252-2070

Barker's Food Machinery Ser.
5367 Second Street
Irwindale, CA 91706
626-960-9390

Chapman Appliance Service
1784 San Diego Ave.
San Diego, CA 92126
619-298-7106

Sterling Service
644 W. Hawthorn Street
Glendale, CA
818-243-1234

COLORADO

Metro Appliance Service
1640 S. Broadway
Denver, CO 80210
303-778-1126

CONNECTICUT

A-Tech Service, Inc.
161 Sanrico Drive
Manchester, CT 06040
860-649-6627

DISTRICT OF COLUMBIA

Electric Motor Repair
700 East 25th Street
Baltimore, MD 21218
410-467-8080

FLORIDA

Commercial Appliance Service
8416 Laurel Fair Circle
Tampa, FL 33610
813-663-0313

Dade Restaurant Repair
2001 W. 27th Street
Hialeah, FL 33010
305-887-0783

GCS
3373 Northwest 168th Street
Miami, FL 33056
305-623-7001

FLORIDA (Cont.)

Nass Service Co. Inc.
1108 S. Woods Ave.
Orlando, FL 32805
407-425-2681

GEORGIA

TWC
5080 Highlands Pkwy S. A150
Smyrna, GA 20082
770-438-9797

HAWAII

Commercial Appliance
Parts & Service Co.
1623 Democratic St.
Honolulu, HI 96819
808-841-4545

IDAHO

Boise Appliance
1503 Main Street
Boise, ID 83702
208-343-0102

ILLINOIS

Eichenauer Food Equipment
130 S. Oakland Ave.
Decatur, IL 62522
217-429-4229

General Parts Inc
248 James Street
Bensenville, IL 60106
630-595-3300

Rescor
5344 East Ave.
Countryside, IL 60525
708-352-3155

INDIANA

GCS
5310 East 25th Street
Indianapolis, IN 46218
317-545-9655

IOWA

Goodwin-Tucker
2900 Delaware Ave
Des Moines, IA 50137
515-262-9308

KANSAS

General Parts, Inc.
1101 E. 13th Street
Kansas City, MO 64101
816-421-5400

KENTUCKY

GCS
4204 S. Brook Street
Louisville, KY 40214
502-367-1788

GCS
533 A Codell Drive
Lexington, KY
859-269-7484

LOUISIANA

Chandler's Parts & Service
11656 Darryl Drive
Baton Rouge, LA 70815
225-272-6620

MARYLAND

Electric Motor Repair CO.
700 East 25th Street
Baltimore, MD 21218
410-467-8080

MASSACHUSETTS

Ace Service Co. Inc.
95 Hampton Ave.
Needham (Boston), MA 02194
617-449-4220

MICHIGAN

E & G Appliance Service Co.
1435 Lawndale Ave.
Detroit, MI 48209
313-842-2252

Midwest Food Equipment Serv.
3055 Dixie
Grandville, MI 49418
616-261-2000

MINNESOTA

GCS
2857 Louisiana Ave. North
Minneapolis, MN 55427
763-546-4221

MISSISSIPPI

Camp Service & Parts Inc.
328 B Oakdale Street
Jackson MS 39201
601-353-9700

MISSOURI

Kaemmerlen Parts & Service
2728 Locust Street
St. Louis, MO 63105
314-535-2222

NEBRASKA

Goodwin-Tucker Group
7535 D Street
Omaha, NE 68124
402-397-2880

NEVADA

Burney's Commercial Service
4480 Aldebaran Ave.
Las Vegas, NV 89103
702-736-0006

NEW MEXICO

R & B Service
4412 Towner N.E.
Albuquerque, NM 87110
505-889-4090

NEW YORK

Acme American Repairs Inc.
99 Scott Ave.
Brooklyn, NY 112237
718-456-6544

Duffys Rest. Equip. Service
3138 Oneida Street
Sauquoit (Utica), NY 13456
315/737-9401

NORTH CAROLINA

Authorized Appliance Service
1020 Tuckaseegee Road
Charlotte, NC 28208
704/377-4501

OHIO

Akron Restaurant Equipment
1169 W. Waterloo Road
Akron, OH 44314
330/753-6635

Commercial Parts & Service
6940 Plainfield Road
Cincinnati, OH 45236
513-984-1900

Electrical Appliance Repair
5805 Valley Belt Road
Cleveland, OH 44131
216-459-8700

OKLAHOMA

Krueger Electric Service Inc.
100 N.E. 24th Street
Oklahoma City, OK 73105
405-528-8883

OREGON

Ron's Service Inc.
16364 S.W. 72nd Ave.
Portland, OR 97224
503-624-0890

PENNSYLVANIA

American Kitchen Mach. Corp.
204 Quarry Street
Philadelphia, PA 19106
215-627-7760

GCS
210 Vista Park Dr.
Pittsburgh, PA 15205
412-787-1970

K & D Parts
1833-41 N. Cameron Street
Harrisburg, PA 17103
717-236-9039

SOUTH CAROLINA

Whaley Foodservice Repairs
137 Cedar Road
Lexington, SC 29171
803-996-9920
800-877-2662

TENNESSEE

A-Tech Inc
424 Sixth Avenue South
Nashville, TN 37203
615-255-2002

FESCO
1209 S. Watkins
Chattanooga, TN 37404
423-624-3381

GCS
3717 Cherry Road
Memphis, TN 38118
901-366-4587

TEXAS

Commercial Kitchen Repair
1377 N. Bravos
San Antonio, TX 78207
210-735-2811

Kenco Service
26 Lyerly - Suite 1
Houston, TX 77022
713-691-2935

Stove Parts Supply Co.
2120 Solana
Fort Worth, TX 76117
817-831-0381

UTAH

LaMonicas Restaurant
Equipment Service
6182 South Stratler
Murray, UT 84107
801-263-3221

VERMONT

Authorized Appliance
74th River Street
Rutland, VT 05701
802-775-5588

VIRGINIA

Daubers Inc.
7645 Dynatech Court
Springfield, VA 22153
703-866-3600

WASHINGTON

Walsh Equipment Repair
1519 128th Place N.E.
Bellevue, WA 98005
425-462-1645

WEST VIRGINIA

Authorized Factory Service
Edens Fork Exit I 77
Charleston, WV 53186
304-344-8225

WISCONSIN

General Parts Inc.
W223 N. 735 Saratoga Dr.
Waukesha, WI 53186
262-650-6666

ALBERTA

Great West Comm. Kit. Rep.
5664 Burleigh Cresc. S.E.
Calgary, AB T2H 1Z8
Tel: 403-276-7832

L.D.I. Technical Services
4 – 3600 21st St. N.E.
Calgary, AB T2E 6V6
Tel: 403-299-9591

North Star Repair
11518 119th Street
Edmonton, AB T5G 2X7
Tel: 780-453-6213

Robertshaw Refrigeration
P.O. Box 840
Cold Lake, AB T9M 1P2
Tel: 780-594-3488

Re-Nu Mechanical Ltd.
1710 Bay F – 31st St. N.
Lethbridge, AB T1H 5H1
Tel: 403-327-7368

Medicine Hat Refrigeration
666 17th Street S.W.
Medicine Hat, AB T1A 4X7

Satellite Mechanical Ltd.
#1 – 5571 45th Street
Red Deer, AB T4N 1L2
Tel: 403-343-6122

BRITISH COLUMBIA

Key Food Equip. Services
180 – 3700 North Fraser
Burnaby, BC V5J 5H4
Tel: 604-433-4484

Marsh & Sons Ventures
10411 – 95th Avenue
Fort St. John, BC V1J 5Z4
Tel: 250-787-9733

J.D. Appliance Repairs
1965 Moss Crt.
Kelowna, BC V1Y 9L3
Tel: 250-860-5057

Jemco Food Equip. Service
7431 Industrial Road
Lantzville, BC V0R 2H0
Tel: 250-390-3244

Sheridan Appliances
764 Chaparral Place
Kamloops, BC V2C 5W4
Tel: 250-314-1722

Mark's Rest. Services
515 Dupplin Road, #3
Victoria, BC V8Z 1C2
Tel: 250-475-6275

Key Food Services
2740 Bridge St., #105
Victoria, BC V8T 5C5
Tel: 250-920-4888

Triumph Food Equip. Service
4671 Slocan Street
Vancouver, BC V5R 1Z8
Tel: 604-454-9326

MANITOBA

Grand Valley Mechanical
360 Park Avenue E.,
Brandon, MB R7A 6N2
Tel: 204-728-3898

Commercial Kitchen Equip.
731 Wall Street
Winnipeg, MB R3G 2T6
Tel: 204-528-8273

Res Tech Service Ltd.
593 Sherburne Street
Winnipeg, MB R3G 2K8
Tel: 204-228-5399

NEW BRUNSWICK

D & L Electric
83 Sister Green Road
Campbellton, NB E3N 3Y5
Tel: 506-753-5076

Electrical & Refrigeration Serv.
88 Beaverbrook Street
Moncton, NB E1C 8H7
Tel: 506-857-2232

EMR
122 Driscoll Avenue
Moncton, NB E1E 3R8
Tel: 506-855-4228

I Line Electric Ltd.
280 Dalton Avenue
Miramichi, NB E1V 3N9
Tel: 506-622-2214

Fundy Gas & Electric
45 Glen Road
Saint John, NB E2H 2C9

NEWFOUNDLAND

Bob's Electric
14 Cooks Avenue
Cornerbrook, NF A2H 1P1
Tel: 709-634-7588

Domestic Service Centre
27 McCurdy Drive, P.O. Box 83
Gander, NF A1V 1W5
Tel: 709-256-7738

Harold Snow & Son Ltd.
451 Kenmount Road
St-John's, NF A1B 3P9
Tel: 709-754-0330

NOVA SCOTIA

Jerome Cameron
R.R. #5, Salt Springs
Antigonish, NS B2G 2L3
Tel: 902-863-4528

Harry Rhyno Refrigeration
233 North Street
Bridgewater, Lun. Co. NS
B4A 2V7
Tel: 902-543-4737

Walker's Electric
2608 Windsor Street
Halifax, NS B3K 5C8
Tel: 902-454-0291

NOVA SCOTIA Continued

Buddens Appliance Service
164 Nichols Avenue
Kentville, NS B4N 2H6
Tel: 902-678-7895

J.R. Mahoney Ltd.
1810 Kings Road
Sydney, NS B1L 1C5
Tel: 902-564-8775

Syd Tech Appliances
Box 1907
Sydney, NS B1P 6W4
Tel: 902-561-0156

Fundy Appliance Service
Truro, NS B2N 5B3
Tel: 902-897-0479

ONTARIO

OFS Restaurant Appl. Serv.
16 Lennox Dr., R.R. #2
Barrie, ON L4M 4S4
Tel: 705-728-5289

ChemMark
52 Highway 17, P.O. Box 371
Chalk River, ON K0J 1J0
Tel: 613-584-2988

Kitchenworks Rest. Equip. Sup
R.R. #5, 823974 Massie Rd.
Chatsworth, ON N0H 1G0
Tel: 519-794-3633

G.R. Garrity
39 Regal Road
Guelph, ON N1K 1B6
Tel: 519-836-1090

Barbers Rest. Eq. & Repairs
927 Barton Street E.
Hamilton, ON L8L 3C4
Tel: 905-527-2525

J.I.K.S. Ind. Kitchen Serv.
42 Groff Place, #4
Kitchener, ON N2E 2L6
Tel: 519-748-5361

R.G. Henderson & Son Ltd.
660A Justus Drive
Kingston, ON K7M 4H4
Tel: 613-384-1718

A-1 Plumbing & Heating
P.O. Box 414
Ilderton, ON N0M 2A0
Tel: 519-455-6559

Action Rest. & Serv. Equip.
151 Bentley Street, #9
Markham, ON L3R 3L1
Tel: 905-475-1499

Stell Mechanical
25 Iron Street
Etobicoke, ON M9W 5E3
Tel: 905-569-8270

Repco Restaurant Equip.
9208 Lundy's Lane
Niagara Falls, ON L2E 6S4
Tel: 905-358-9071

ONTARIO Continued

Blanchfield Comm. Kit. Serv.
770 Industrial Ave., Unit 13
Ottawa, ON K1G 4H3
Tel: 613-737-6632

McNabb Appliances
370 Burnham Street
Peterborough, ON K9H 1T6
Tel: 705-743-5350

Erlmar Plumbing Ltd.
795 Batory Avenue
Pickering, ON L1W 2W5
Tel: 905-420-5252

Sure-Fix Food Equip. Serv.
52 Vine Street S.
St. Catharines' ON L2R 3X8
Tel: 905-685-0480

W.J. Barnes & Son
116 Talford Street
Sarnia, ON N7T 7J2
Tel: 519-332-1770

Sault Rapid Repair
1496 Wellington St. E.
Sault Ste. Marie, ON P6A 2R1
Tel: 705-759-3311

Tisdale Plumbing & Heating
40 Golden Avenue
South Porcupine, ON P0N 1H0
Tel: 705-235-4045

Sudbury Rapid Service
23 Main Street
Chelmsford, ON P0M 1L0
Tel: 705-671-6477

Jemm Service
1211 Ford Street
Thunder Bay, ON P3A 4R8
Tel: 807-623-7851

R.G. Henderson & Son Ltd.
100 Thorncliff Park Dr.
Toronto, ON M4H 1G9
Tel: 416-423-4357

P.E.I.

Waites Enterprises
626 South Drive
Summerside, PEI C1N 3Z7
Tel: 902-436-7509

QUEBEC

Choquette CKS
8487 19th Avenue
Montreal, QC H1Z 4J2
Tel: 514-723-5000

L. Chasse Inc.
448 Richelieu
Pointe au Pic, QC G5M 1C9
Tel: 418-723-9100

Majella Vaillancourt
82 St. Cyrille
Riviere de Loup, QC G5R 2G8
Tel: 418-862-2503

QUEBEC

Electro Ref. Service Ent.
161 Pere Divet
Sept-Iles, QC G4R 3P8
Tel: 418-962-9186

Kitchen Equipment Services
893 King Street W.
Sherbrooke, QC J1H 1R9
Tel: 819-821-2153

Choquette CKS
900 Pierre Bertrand, #220
Ville Vanier, QC G1M 3K2
Tel: 418-681-3944

SASKATCHEWAN

Comfort Mechanical
1355 11th Avenue
Regina, SK S4P 0G8
Tel: 306-352-0544

Northcote Sales & Serv. Co.
1327 Hamilton Street
Regina, SK S4R 2B6
Tel: 306-525-1979

Evan's Restaurant Serv.
410 Lauriston Street
Saskatoon, SK S7K 0R5
Tel: 306-653-2772

YUKON

Oscar's Electric
310 Alexander St.
Whitehorse, YK Y1A 2L6
Tel: 867-667-2330

Yukon Appliance Sales & Serv.
9041 Quartz Road
White Horse, YK Y1A 4Z5
Tel: 867-668-4844

NOTES

BURNISHER OWNERS MANUAL



BLAKESLEE

Revised 01/2013

