



**DFG-100-ES AND DFG-200-ES
CONVECTION OVEN
INSTALLATION - OPERATION - MAINTENANCE**



BLODGETT OVEN COMPANY

www.blodgett.com

42 Allen Martin Drive, Essex Junction, Vermont 05452 USA Telephone: (802) 658-6600 Fax: (802)864-0183

PN 57932 Rev J (9/19)

© 2019 - G.S. Blodgett Corporation

Your Service Agency's Address:

Model

Serial number

Oven installed by

Installation checked by

IMPORTANT

WARNING: Improper installation, adjustment, alternation, service or maintenance can cause property damage, injury or death. Read the installation, operation and maintenance instructions thoroughly before installing or servicing this equipment.

INSTRUCTIONS TO BE FOLLOWED IN THE EVENT THE USER SMELLS GAS MUST BE POSTED IN A PROMINENT LOCATION. This information may be obtained by contacting your local gas supplier.

FOR YOUR SAFETY

Do not store or use gasoline or other flammable vapors or liquids in the vicinity of this or any other appliance.

The information contained in this manual is important for the proper installation, use, and maintenance of this oven. Adherence to these procedures and instructions will result in satisfactory baking results and long, trouble free service. Please read this manual carefully and retain it for future reference.

ERRORS: Descriptive, typographic or pictorial errors are subject to correction. Specifications are subject to change without notice.

TABLE OF CONTENTS

INSTALLATION

Oven Description and Specifications	2
Delivery and Location	3
Oven Assembly	4
NSF Bolts	4
Leg Attachment	5
Caster Assembly	5
Double Section Assembly	6
Oven Leveling	6
Ventilation	7
Utility Connections - Standards and Codes	9
Gas Connection	10
Gas Piping	10
Pressure Regulation and Testing	11
Gas Hose Restraint	12
Electrical Connection	13
Initial Startup	14

OPERATION

Safety Information	15
SSD - Solid State Digital Control	16
SSI-D Infinite Control w/Digital Timer	18
SSI-M Infinite Control w/Manual Timer	19
Simple Touch Control	20
How Cook & Hold Works	34
General Guidelines for Operating Personnel	35
Suggested Times and Temperatures	36

MAINTENANCE

Cleaning and Preventative Maintenance	37
Troubleshooting Guide	38



Installation

Oven Description and Specifications

Cooking in a convection oven differs from cooking in a conventional deck or range oven since heated air is constantly recirculated over the product by a fan in an enclosed chamber. The moving air continually strips away the layer of cool air surrounding the product, quickly allowing the heat to penetrate. The result is a high quality product, cooked at a lower temperature in a shorter amount of time.

Blodgett convection ovens represent the latest advancement in energy efficiency, reliability, and ease of operation. Heat normally lost, is recirculated within the cooking chamber before being vented from the oven: resulting in substantial reductions in energy consumption and enhanced oven performance.

GAS RATINGS - DFG-100-ES AND DFG-200-ES				
	Natural Gas		Propane	
	US Units	SI Units	US Units	SI Units
U.S., Canada and General Export				
Heating Value	1000 BTU/cu.ft.	37.3 MJ/m ³	2550 BTU/cu. ft.	95.0 MJ/m ³
Specific Gravity (air=1.0)	0.63	0.63	1.53	1.53
Oven Input				
DFG-100-ES	45,000 BTU/hr	13.12 kW	45,000 BTU/hr	13.12 kW
DFG-200-ES	50,000 BTU/hr	14.7 kW	50,000 BTU/hr	14.7 kW
Main Burner Orifice Size				
DFG-100-ES (3 inshot burners)	49 MTD*/burner	1.85 mm/burner	2 burners - 57 MTD* 1 burner - 56 MTD	2 burners - 1.10 mm 1 burner - 1.15 mm
DFG-200-ES (4 inshot burners)	50 MTD/burner	1.78 mm/burner	60 MTD*	1.00 mm
<i>NOTE: * - Multiple Twist Drill</i>				

Delivery and Location

DELIVERY AND INSPECTION

All Blodgett ovens are shipped in containers to prevent damage. Upon delivery of your new oven:

- Inspect the shipping container for external damage. Any evidence of damage should be noted on the delivery receipt which must be signed by the driver.
- Uncrate the oven and check for internal damage. Carriers will accept claims for concealed damage if notified within fifteen days of delivery and the shipping container is retained for inspection.

The Blodgett Oven Company cannot assume responsibility for loss or damage suffered in transit. The carrier assumed full responsibility for delivery in good order when the shipment was accepted. We are, however, prepared to assist you if filing a claim is necessary.

OVEN LOCATION

The well planned and proper placement of your oven will result in long term operator convenience and satisfactory performance.

The following clearances must be maintained between the oven and any combustible or non-combustible construction.

DFG-100-ES and DFG-200-ES

- Oven body right side - 0" (0cm)
- Oven body left side - 0" (0cm)
- Oven body back - 0" (0cm)
- Single and stacked oven bottom - 0" (0cm)

The following clearances must be available for servicing.

- Oven body sides - 12" (30cm)
- Oven body back - 12" (30cm)

NOTE: On gas models, routine servicing can usually be accomplished within the limited movement provided by the gas hose restraint. If the oven needs to be moved further from the wall, the gas must first be turned off and disconnected from the oven before removing the restraint. Reconnect the restraint after the oven has been returned to its normal position.

It is essential that an adequate air supply to the oven be maintained to provide a sufficient flow of combustion and ventilation air.

- Place the oven in an area that is free of drafts.
- Keep the oven area free and clear of all combustibles such as paper, cardboard, and flammable liquids and solvents.
- NSF requires 6" of clearance on the bottom and sides of the unit for cleaning. Do not place the oven on a curb base or seal to a wall.
- The location must provide adequate clearance for the air opening into the combustion chamber.

Before making any utility connections to this oven, check the rating plate to be sure the oven specifications are compatible with the gas and electrical services supplied for the oven.

1. Pull out control panel. The rating plate is attached to the inside of the control compartment.
- Do not place strong sources of heat such as open flame ranges, griddles, or charbroilers near the oven. If such an instance exists, it is highly recommended to purchase a heat shield, available from Blodgett.
 - Note that if temperatures are too high, a safety shut-down may occur.
 - Failure to comply may invalidate the oven warranty.



Installation

Oven Assembly

NSF BOLTS

These bolts are required by NSF to block any exposed hole on the back of an oven. This includes:

- any unit, single or stacked, without a back panel.
- any holes in stacked units not used for mounting stacking brackets.

1. Locate the 5/16" bolts that were shipped with the oven.
2. Install the bolts as shown.

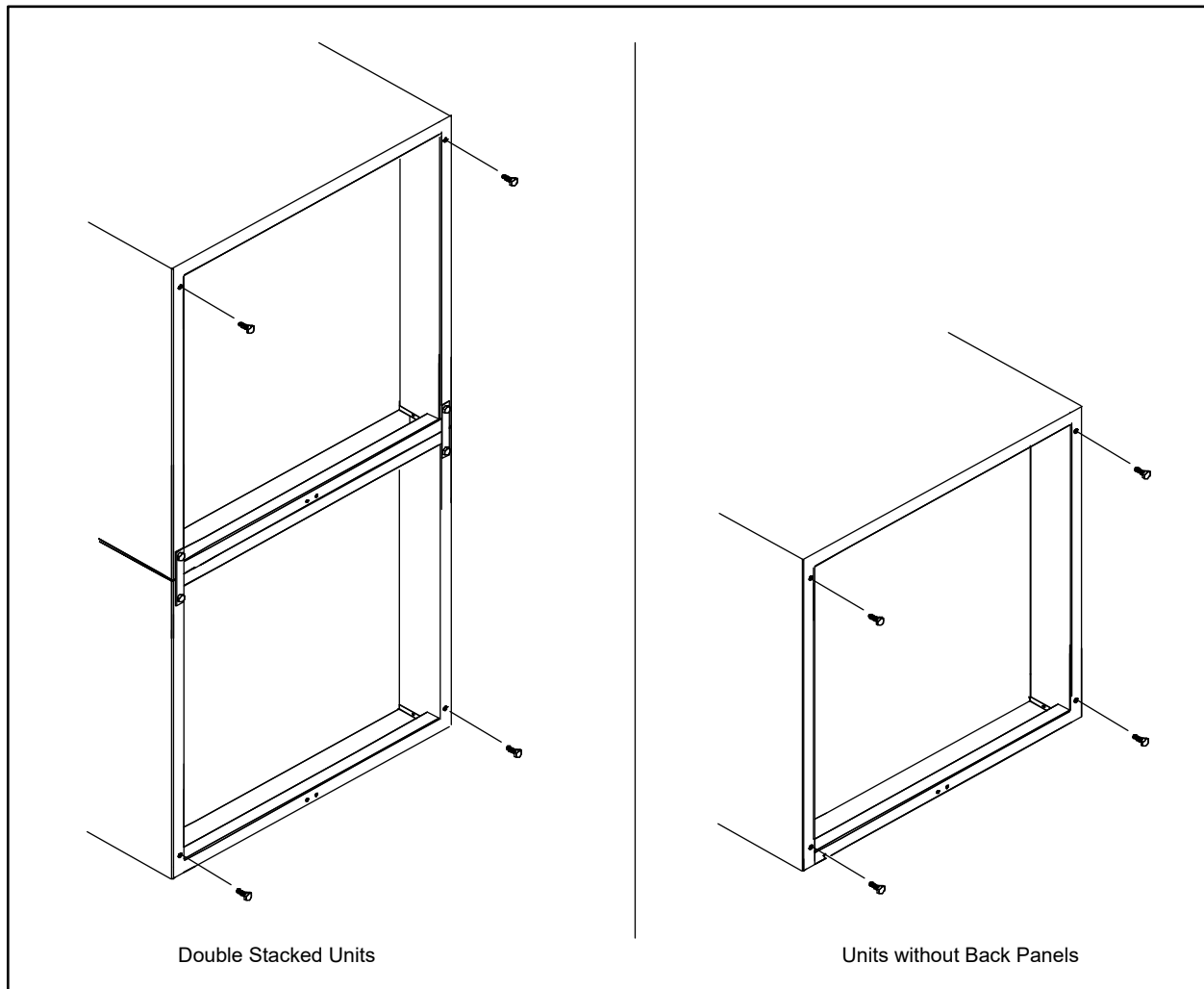

Figure 1



Oven Assembly

LEG ATTACHMENT

1. Push the oven onto a lift with the bottom of the oven down.
2. Align the threaded stud in each leg with the nut located inside each bottom corner of the oven frame. Turn the legs clockwise and tighten to the nearest full turn.
3. Align the two leg plate holes in each leg with those in the oven bottom. Secure each leg using two 1/2" bolts.

NOTE: If using casters see CASTER ASSEMBLY before proceeding.

4. Level the oven by screwing the adjustable leg feet in or out as necessary.

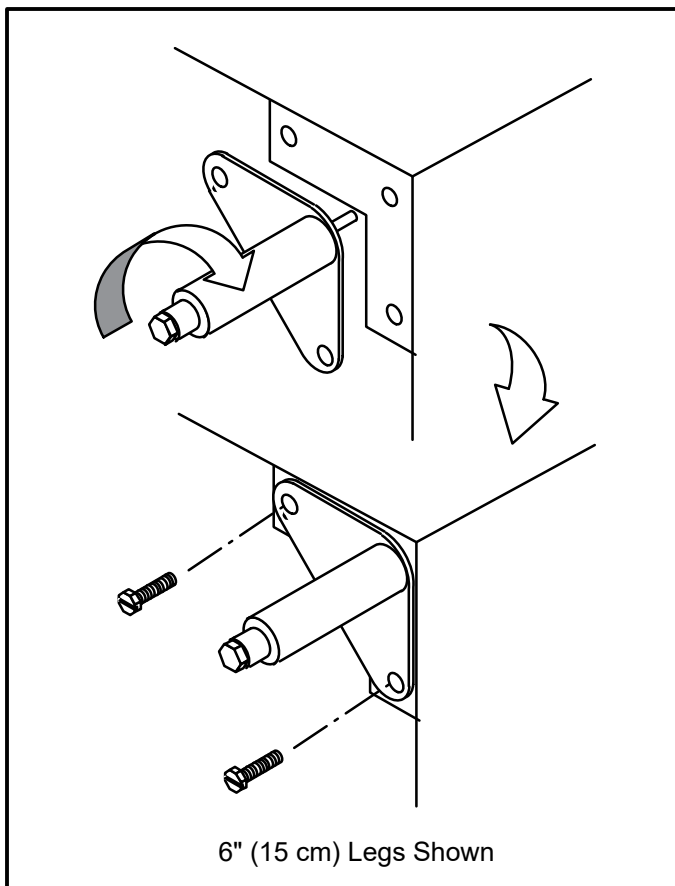

Figure 2

CASTER ASSEMBLY

NOTE: Install the locking casters on the front of the oven. Install the non-locking casters on the back of the oven.

NOTE: Use a gas hose restraint on all units with casters.

Castors for Single and Double Stacked Ovens:

1. Attach the legs as described.
2. Pry the adjustable feet out of the legs.
3. Insert one caster into each leg as shown. Tighten the lock nuts to secure the casters.

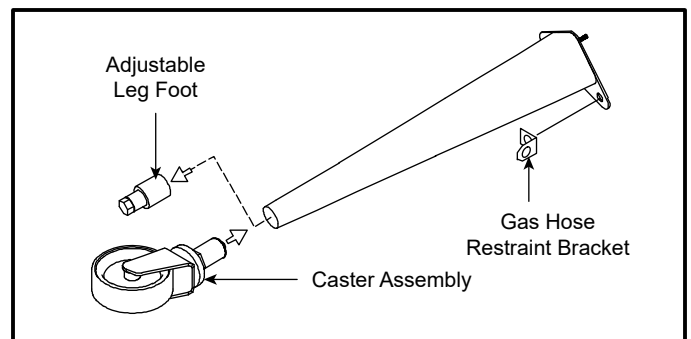

Figure 3

Low Profile Casters for Double Stacked Ovens:

1. Align the three holes in each caster assembly plate with those in the oven bottom. Secure each caster using three 1/2" bolts.

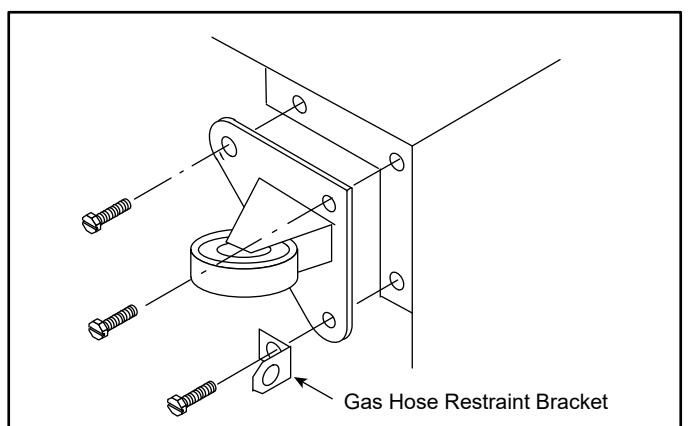

Figure 4



Installation

Oven Assembly

DOUBLE SECTION ASSEMBLY

1. Secure the short legs to the bottom sections as described.
2. Place the upper section in position on top of the lower oven.
3. Attach the stacking brackets using the remaining 5/16" bolts shipped with the ovens.
4. Attach the draft diverter to the bottom oven. **DO NOT** install the draft diverter guard on the bottom oven.
5. Install the flue riser on the top oven. The bottom of the flue riser slides down over the draft diverter on the bottom oven. Secure with 12 screws.
6. Install the flue riser guard as shown below.

OVEN LEVELING

After assembly, the oven should be leveled and moved to the operating location.

1. The oven can be leveled by adjusting the feet or casters located on the bottom of each leg.

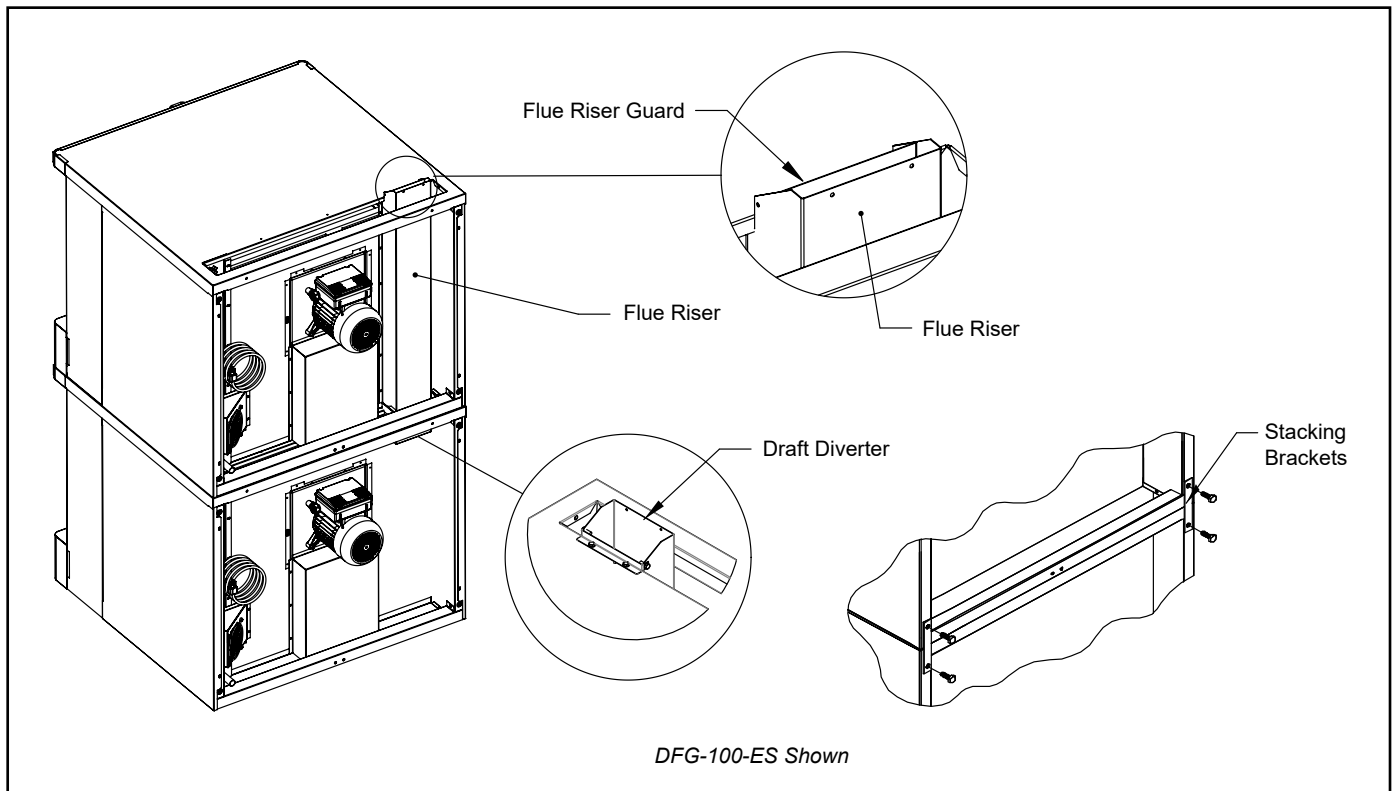

Figure 5

On gas models the installation of a proper ventilation system cannot be over emphasized. This system removes unwanted vapors and products of combustion from the operating area.

This oven may be vented using either:

- A mechanically driven, canopy type, exhaust hood, or
- A direct flue arrangement.

U.S. and Canadian installations

Refer to your local ventilation codes. In the absence of local codes, refer to the National ventilation code titled, "Standard for the Installation of Equipment for the Removal of Smoke and Grease Laden Vapors from Commercial Cooking Equipment", NFPA-96-Latest Edition.

General export installations

Installation must conform with Local and National installation standards. Local installation codes and/or requirements may vary. If you have any questions regarding the proper installation and/or operation of your Blodgett oven, please contact your local distributor. If you do not have a local distributor, please call the Blodgett Oven Company at 0011-802-658-6600.



WARNING:

Failure to properly vent the oven can be hazardous to the health of the operator and may result in operational problems, unsatisfactory baking and possible damage to the equipment.

Damage sustained as a direct result of improper ventilation will not be covered by the manufacturer's warranty.

CANOPY TYPE EXHAUST HOOD

A mechanically driven, canopy type exhaust hood is the preferred method of ventilation.

The hood should be sized to completely cover the equipment plus an overhang of at least 6" (15 cm) on all sides not adjacent to a wall. The distance from the floor to the lower edge of the hood should not exceed 7' (2.1m).

The total makeup and exhaust air requirements for hood capacity should be approximately 30 CFM (.85 m³) for each oven section.

Installing the canopy hood draft diverter

Ovens ordered for hood venting are supplied with a draft diverter. Install the draft diverter as follows:

1. Place the draft diverter on the oven back and slide it up through the rectangular hole in the oven body top. Secure to the oven body back with four screws.
2. Secure the draft diverter guard to the draft diverter with four screws.

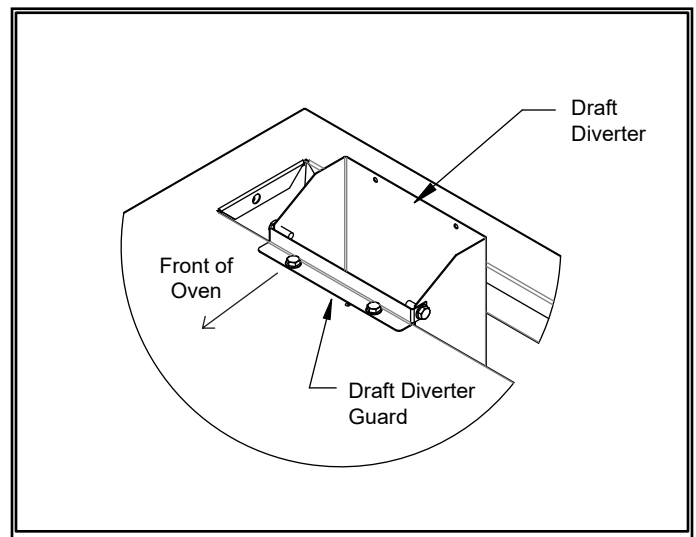

Figure 6



Installation

Ventilation

DIRECT FLUE ARRANGEMENT

When the installation of a mechanically driven exhaust hood is impractical the oven may be vented by a direct flue arrangement.

 **WARNING!!**

It is essential that the direct flue be installed as follows. Incorrect installation will result in unsatisfactory baking and oven damage.

The flue must be class B or better. The height of the flue should rise 6-8 ft (2-2.5 m) above the roof of the building or any proximate structure. Never direct vent the oven into a hood. The flue should be capped with a UL Listed type vent cap to isolate the unit from external environmental conditions.

The direct vent cannot replace air consumed and vented by the oven. Provisions must be made to supply the room with sufficient make-up air. Total make-up air requirements for each oven section should be approximately 30 CFM (.85 m³) per section. To increase the supply air entering the room, a ventilation expert should be consulted.

FLUE DIAMETER		
Oven	Single	Double
DFG-100-ES	6" (15cm)	6" (15cm)
DFG-200-ES	6" (15cm)	6" (15cm)

Installing the draft hood

Ovens ordered for direct venting are supplied with a draft hood. Install the draft hood as follows:

1. Install draft diverter using the screws provided as shown below.
2. Place the draft hood over the draft diverter.
3. Secure both ends with the sheet metal screws provided.

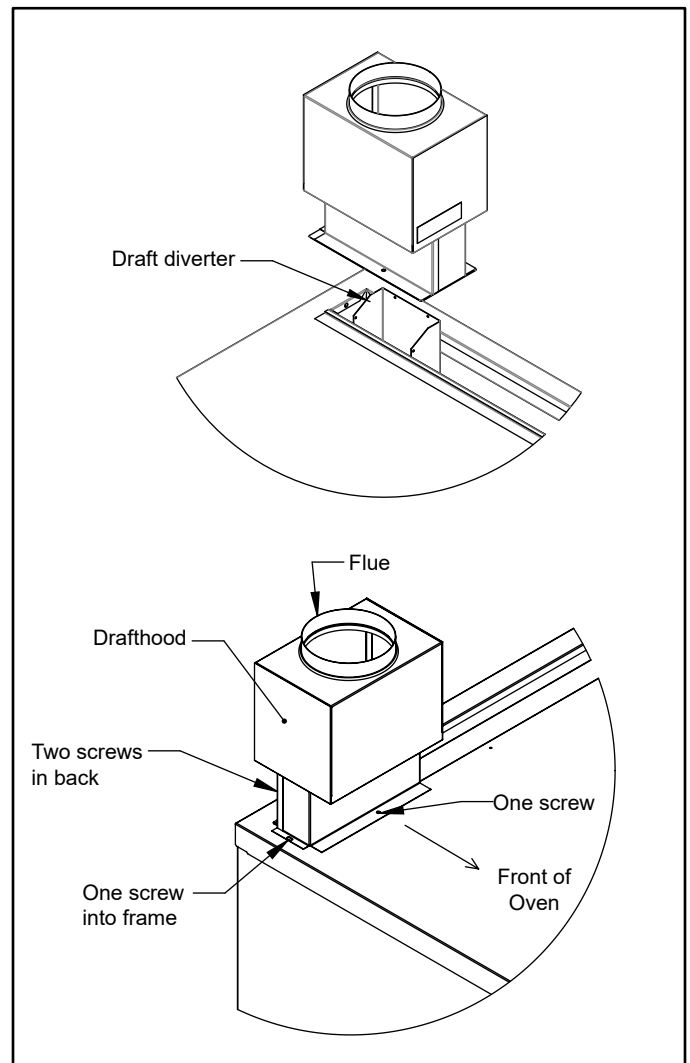

Figure 7

Utility Connections - Standards and Codes

THE INSTALLATION INSTRUCTIONS CONTAINED HEREIN ARE FOR THE USE OF QUALIFIED INSTALLATION AND SERVICE PERSONNEL ONLY. INSTALLATION OR SERVICE BY OTHER THAN QUALIFIED PERSONNEL MAY RESULT IN DAMAGE TO THE OVEN AND/OR INJURY TO THE OPERATOR.

Qualified installation personnel are individuals, a firm, a corporation, or a company which either in person or through a representative are engaged in, and responsible for:

- the installation or replacement of gas piping and the connection, installation, repair or servicing of equipment.
- the installation of electrical wiring from the electric meter, main control box or service outlet to the electric appliance.

Qualified installation personnel must be experienced in such work, familiar with all precautions required, and have complied with all requirements of state or local authorities having jurisdiction.

U.S. and Canadian installations

The installation must conform with local codes, or in the absence of local codes, with the National Fuel Gas Code, ANSI Z223.1/NFPA 54, or the Natural Gas and Propane Installation Code, CSA B149.1, as applicable.

Installation must conform with local codes, or in the absence of local codes, with the National Electrical Code, ANSI/NFPA 70-Latest Edition and/or Canadian National Electric Code C22.1 as applicable.

Appliance is to be installed with backflow prevention in accordance with applicable federal, province and local codes.

General export installations

Installation must conform with Local and National installation standards. Local installation codes and/or requirements may vary. If you have any questions regarding the proper installation and/or operation of your Blodgett oven, please contact your local distributor. If you do not have a local distributor, please call the Blodgett Oven Company at 0011-802-658-6600.





Installation

Gas Connection

GAS PIPING

A properly sized gas supply system is essential for maximum oven performance. Piping should be sized to provide a supply of gas sufficient to meet the maximum demand of all appliances on the line without loss of pressure at the equipment.

Example:

NOTE: BTU values in the following example are for natural gas.

You purchase a DFG-100-ES to add to your existing cook line.

1. Add the BTU rating of your current appliances.

Pitco Fryer	120,000 BTU
6 Burner Range	60,000 BTU
Deck Oven	50,000 BTU
Total	230,000 BTU

2. Add the BTU rating of the new oven to the total.

Previous Total	230,000 BTU
DFG-100-ES	45,000 BTU
New Total	275,000 BTU

3. Measure the distance from the gas meter to the cook line. This is the pipe length. Let's say the pipe length is 40' (12.2 m) and the pipe size is 1" (2.54 cm).

4. Use the appropriate table to determine the total capacity of your current gas piping.

The total capacity for this example is 320,000 BTU. Since the total required gas capacity, 275,000 BTU is less than 320,000 BTU, the current gas piping will not have to be increased.

NOTE: The BTU capacities given in the tables are for straight pipe lengths only. Any elbows or other fittings will decrease pipe capacities. Contact your local gas supplier if you have any questions.

Maximum Capacity of Iron Pipe in Cubic Feet of Natural Gas Per Hour

(Pressure drop of 0.5 Inch W.C.)

PIPE LENGTH (FT)	NOMINAL SIZE, INCHES				
	3/4"	1"	1-1/4"	1-1/2"	2"
10	360	680	1400	2100	3950
20	250	465	950	1460	2750
30	200	375	770	1180	2200
40	170	320	660	990	1900
50	151	285	580	900	1680
60	138	260	530	810	1520
70	125	240	490	750	1400
80	118	220	460	690	1300
90	110	205	430	650	1220
100	103	195	400	620	1150

From the National Fuel Gas Code Part 10 Table 10-2

Maximum Capacity of Pipe in Thousands of BTU/hr of Undiluted L.P. Gas at 11" W.C.

(Pressure drop of 0.5 Inch W.C.)

PIPE LENGTH (FT)	OUTSIDE DIAMETER, INCHES		
	3/4"	1"	1-1/2"
10	608	1146	3525
20	418	788	2423
30	336	632	1946
40	287	541	1665
50	255	480	1476
60	231	435	1337
70	215	404	1241
80	198	372	1144
90	187	351	1079
100	175	330	1014

From the National Fuel Gas Code Part 10 Table 10-15

Gas Connection

PRESSURE REGULATION AND TESTING

DFG-100-ES ovens are rated at 45,000 BTU/Hr. (13.2 kW) (48 MJ) per section. DFG-200-ES ovens are rated at 50,000 BTU/Hr. (14.7 kW) (52 MJ) per section. Each oven has been adjusted at the factory to operate with the type of gas specified on the rating plate.

INLET PRESSURE					
	Natural		Propane		
	Min	Max	Min	Max	
W.C.	7.0	10.5	11.0	13.0	
kPa	1.742	2.61	2.74	3.23	
MANIFOLD PRESSURE					
	Natural		Propane		
	W.C.		10.0		
kPa		.87		2.49	

- Inlet Pressure - the pressure of the gas before it reaches the oven.
- Manifold Pressure - the pressure of the gas as it enters the main burner(s).
- Min - the minimum pressure recommended to operate the oven.
- Max - the maximum pressure at which the manufacturer warrants the oven's operation.

Each oven is supplied with a regulator to maintain the proper gas pressure. The regulator is essential to the proper operation of the oven and should not be removed. It is preset to provide the oven with 3.5" W.C. (0.87 kPa) for natural gas and 10.0" W.C. (2.50 kPa) for Propane at the manifold.

DO NOT INSTALL AN ADDITIONAL REGULATOR WHERE THE OVEN CONNECTS TO THE GAS SUPPLY UNLESS THE INLET PRESSURE IS ABOVE MAXIMUM.

Prior to connecting the oven, gas lines should be thoroughly purged of all metal filings, shavings, pipe dope, and other debris. After connection, the oven should be checked for correct gas pressure.

The oven and its individual shutoff valve must be disconnected from the gas supply piping system during any pressure testing of that system at test pressures in excess of 1/2 psig (13.85" W.C., 3.45 kPa).

The oven must be isolated from the gas supply piping system by closing its individual manual shutoff valve during any pressure testing of the gas piping system at test pressures equal or less than 1/2 psig (13.85" W.C., 3.45 kPa).

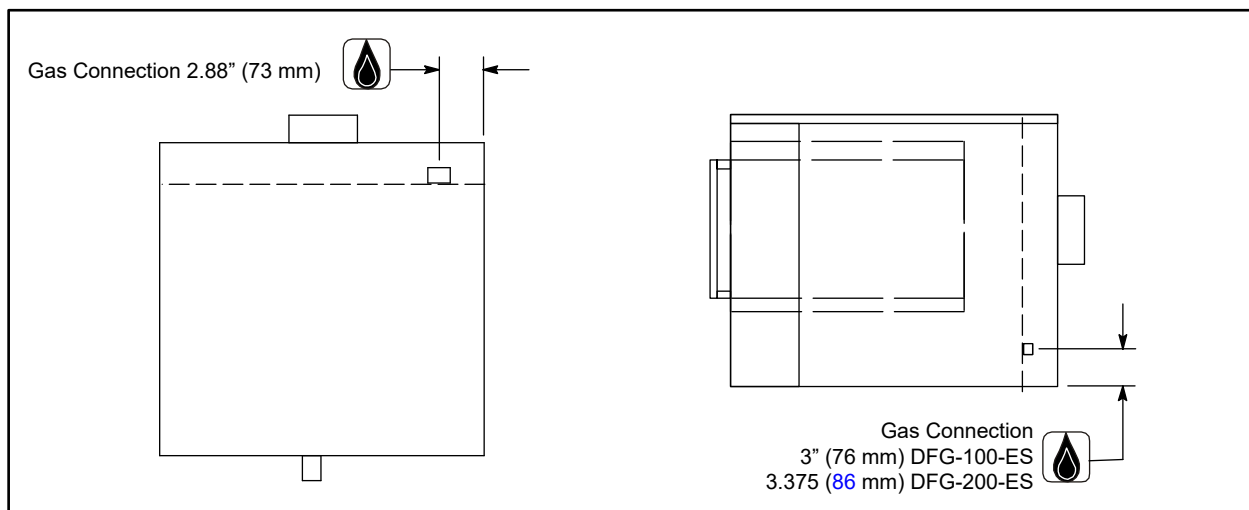

Figure 8



Installation

Gas Connection

GAS HOSE RESTRAINT

If the oven is mounted on casters, a commercial flexible connector with a minimum of 3/4" (1.9 cm) inside diameter must be used along with a quick connect device.

The restraint, supplied with the oven, must be used to limit the movement of the unit so that no strain is placed upon the flexible connector. With the restraint fully stretched the connector should be easy to install and quick connect.

The restraint (ie: heavy gauge cable) should be 1,000 lb. (453 kg) test load and should be attached without damaging the building. **DO NOT** use the gas piping or electrical conduit for the attachment of the permanent end of the restraint! Use anchor bolts in concrete or cement block. On wooden walls, drive hi test wood lag screws into the studs of the wall.

1. Mount the supplied bracket to the leg bolt just below the gas inlet.
2. Attach the clip on restraining cable to the mounting bracket.

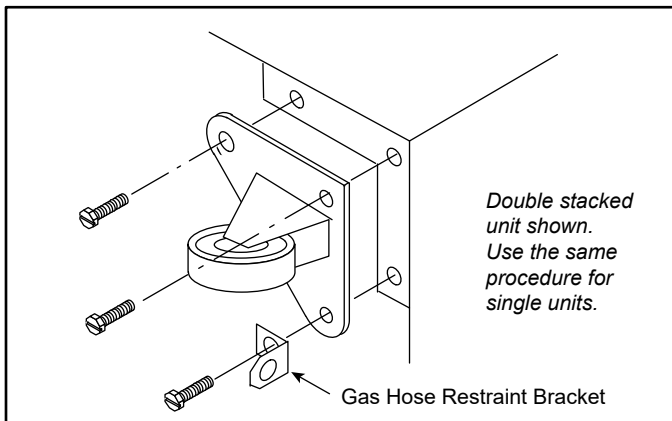

Figure 9



WARNING!!

If the restraint is disconnected for any reason it must be reconnected when the oven is returned to its original position.

U.S. and Canadian installations

The connector must comply with the Standard for Connectors for Movable Gas Appliances, ANSI Z21.69 or Connectors For Moveable Gas Appliances CAN/CGA-6.16 and a quick disconnect device that complies with the Standard for Quick-Disconnect Devices for Use With Gas Fuel, ANSI Z21.41 or Quick Disconnect For Use With Gas Fuel CAN 1-6.9. Adequate means must be provided to limit the movement of the appliance without depending on the connection and the quick disconnect device or its associated piping.

General export installations

The restraint and quick connect must conform with Local and National installation standards. Local installation codes and/or requirements may vary. If you have any questions regarding the proper installation and/or operation of your Blodgett oven, please contact your local distributor. If you do not have a local distributor, please call the Blodgett Oven Company at 0011-802-658-6600.

Electrical Connection

Wiring diagrams are located in the control compartment and on the back of the oven.

This oven is supplied for connection to 115 volt grounded circuits. The electric motor, indicator lights and related switches are connected through the 6' electric supply cord found at the rear of the oven.



WARNING!!

This appliance is equipped with three prong grounding type plug for your protection against shock hazard and should be plugged directly into a properly grounded three prong receptacle. DO NOT cut or remove the grounding prong from this plug.

The Blodgett Oven Company cannot assume responsibility for loss or damage suffered as a result of improper installation.

ELECTRICAL SPECIFICATIONS - DFG-100-ES AND DFG-200-ES

Hz	Volts	Phase	Amps	Electrical Connection (minimum size)
60	115	1	8	Cord set provided



Installation

Initial Startup

The following is a check-list to be completed by **qualified technician** prior to turning on the appliance for the first time.

1. Open the manual shut-off valve at the rear of the oven.
2. Remove the control panel and combustion covers.
3. Verify the combination valve's manual shut-off is in the on position.
4. Turn the selector switch to Cook, and the thermostat to 500°F (260°C).

The oven main burner lights, and the Oven Heating Light comes on. With the main burner on, check the following.

1. Verify there are no gas leaks, by checking all gas connections with a soapy water solution.
2. Verify that the inlet pressure is correct. The inlet pressure can be checked at the pressure tap located on the combination valve's inlet side.
3. Verify that the manifold pressure is correct. The manifold pressure can be checked at the pressure tap located on the combination valve's outlet side.
4. If the above pressure readings are set to the recommended pressure requirements, allow the oven to burn-off for 2 hours. If the pressure readings are not set correctly, turn off the oven and readjust accordingly.



WARNING

The break in procedure burns off excess oils present in the metals during fabrication. Smoke may be produced. Proper ventilation is required.

Adjustments associated with initial installation

Each oven, and its component parts, have been thoroughly tested and inspected prior to shipment. However, it is often necessary to further test or adjust the oven as part of a normal and proper installation. These adjustments are the responsibility of the installer, or dealer. Since these adjustments are not considered defects in material or workmanship, they are not covered by the Original Equipment Warranty. They include, but are not limited to:

- calibration of the thermostat
- adjustment of the doors
- burner adjustments
- leveling
- testing of gas pressure
- tightening of fasteners.

No installation should be considered complete without proper inspection, and if necessary, adjustment by qualified installation or service personnel.

The information contained in this section is provided for the use of qualified operating personnel. Qualified operating personnel are those who have carefully read the information contained in this manual, are familiar with the functions of the oven and/or have had previous experience with the operation of the equipment described. Adherence to the procedures recommended herein will assure the achievement of optimum performance and long, trouble-free service.

Please take the time to read the following safety and operating instructions. They are the key to the successful operation of your Blodgett oven.



SAFETY TIPS

For your safety read before operating

What to do if you smell gas:

- DO NOT try to light any appliance.
- DO NOT touch any electrical switches.
- Use an exterior phone to call your gas supplier immediately.
- If you cannot reach your gas supplier, call the fire department.

What to do in the event of a power failure:

- Turn all switches to off.
- DO NOT attempt to operate the oven until the power is restored.

NOTE: In the event of a shut-down of any kind, allow a five (5) minute shut off period before attempting to restart the oven.

General safety tips:

- DO NOT use tools to turn off the gas control. If the gas cannot be turned off manually do not try to repair it. Call a qualified service technician.
- If the oven needs to be moved for any reason, the gas must be turned off and disconnected from the unit before removing the restraint cable. Reconnect the restraint after the oven has been returned to its original location.
- DO NOT remove the control panel cover unless the oven is unplugged.



Operation

SSD - Solid State Digital Control

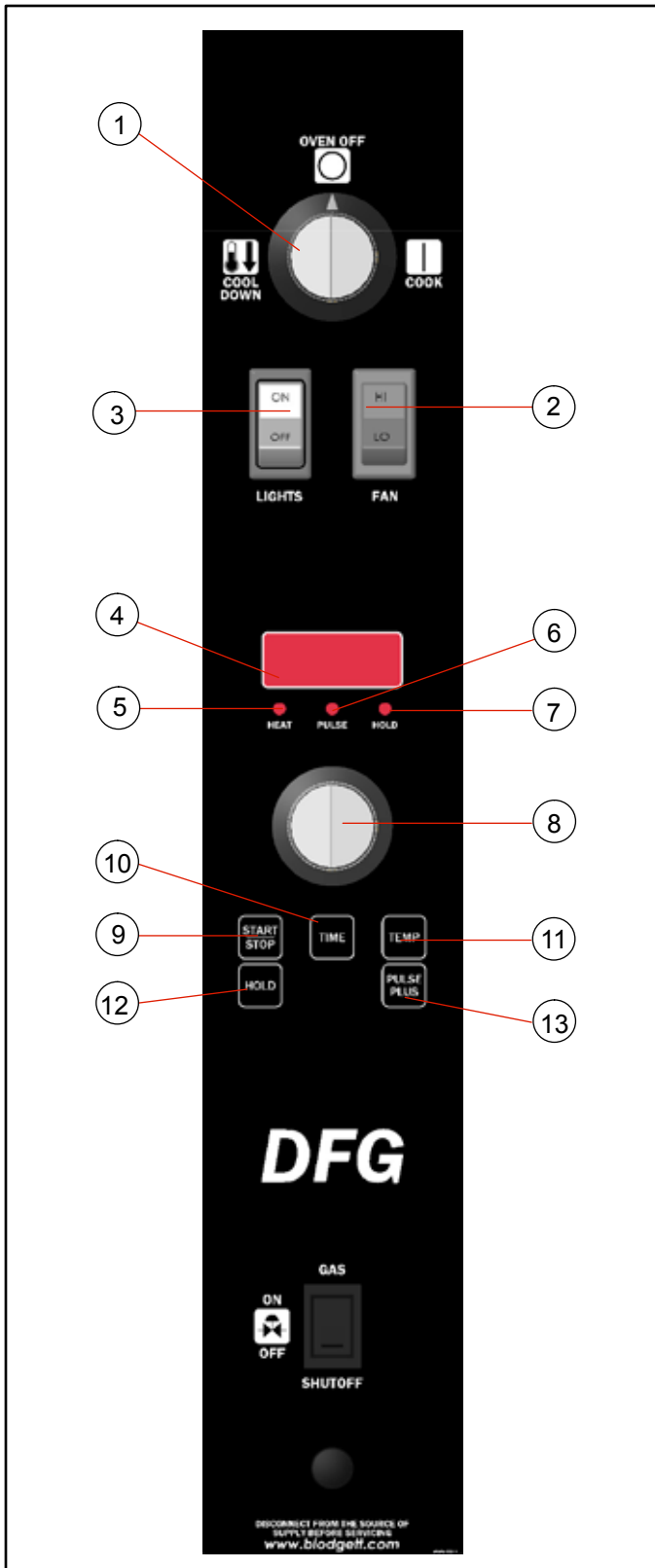

Figure 10

CONTROL DESCRIPTION

1. SELECTOR SWITCH - turns power to the oven on or off. Allows selection of Cook or Cool Down Modes and fan speed (if applicable).
2. BLOWER SWITCH - controls blower speed, either hi or lo.
3. LIGHTS SWITCH - controls interior lights.
4. DISPLAY - displays time or temperature and other information related to oven function.
5. HEAT LAMP - lights when heater is on.
6. PULSE LAMP - lights when Pulsed Fan Mode is turned on.
7. HOLD LAMP - lights when Hold Mode is turned on.
8. DIAL - used to enter set points in display
9. START/STOP KEY - starts or stops the timer.
10. TIME KEY - used to show time in the display.
11. TEMP KEY - used to show set temperature in the display.

NOTE: Actual temperature is shown while the TEMP key is held down.

12. HOLD KEY - turns Hold Mode on or off.
13. PULSE KEY - turns Pulse Mode on or off.

PROGRAMMING

To set the cook temperature:

1. Press TEMP (11) key.
2. Rotate dial (8) to enter temperature.

To set the cook time:

1. Press TIME (10) key.
2. Rotate the dial (8) to enter time.

NOTE: Time is entered in hours : minutes or minutes : seconds.

To set the hold time:

1. Press HOLD key (12) to turn hold mode on.
NOTE: HOLD light is on.
2. Rotate dial (8) to enter the hold temperature.
3. Press START/STOP key (9)



SSD - Solid State Digital Control

TO SET THE PULSE TIME:

1. Press PULSE KEY (13) to turn pulse mode on.
NOTE: Pulse light is on.
2. Rotate DIAL (8) to enter the pulse time. Pulse time is a portion of the pre-set cook time.

OPERATION

Cook Only:

1. Turn the SELECTOR switch (1) to the desired position.
2. Enter the cook time and temperature.
3. Load product into the oven.
NOTE: The display reads LOAD when the oven is near the set temperature.
4. Press the START/STOP key (9). The timer begins to count down.
5. When the cook timer reaches 00:00 the buzzer sounds and the display reads DONE.
6. Press the START/STOP key (9) to silence the buzzer.
7. Remove the product.

Cook with Hold:

NOTE: HOLD light is on when hold mode is on and off when hold mode is off.

1. Turn the SELECTOR switch (1) to the desired position.
2. Enter the cook time and temperature.
3. Press the HOLD key (12). Enter the hold temperature.
4. Load product into the oven.
NOTE: The display reads LOAD when the oven is near the set temperature.
5. Push the START/STOP (9) key. Timer begins to count down.
6. When the cook timer reaches 00:00 the buzzer sounds and the display reads DONE. The buzzer turns off after a few seconds. The display reads HOLD until the oven reaches the hold temperature. Then the timer begins to count up.
7. Push the START/STOP key (9) to stop timer.
8. Remove the product.
9. Push HOLD (12) key to turn off hold mode.

Cook with Pulse:

NOTE: PULSE light is on when pulse mode is on and off when pulse mode is off.

1. Turn the SELECTOR SWITCH (1) to the desired position.
2. Enter cook time and cook temperature.
3. Press PULSE KEY (13). Enter the pulse time.
NOTE: Pulse time is a portion of the cook time and does not increase the previously entered cook time.
4. Load product into the oven.
NOTE: The display reads LOAD when the oven is near the set temperature.
5. Push START/STOP KEY (9). The timer begins to count down the cook time. The oven will be in pulse mode for the set pulse time. Once the set time has expired, the unit will automatically switch to cook mode and continue counting down.
6. When the cook timer reaches 00:00 the buzzer sounds and the display reads DONE.
7. Push the START/STOP KEY (9) to turn the buzzer off.
8. Remove the product.



WARNING!!

A complete five minute shutdown must be observed before the oven is relighted.



Operation

SSI-D Infinite Control w/Digital Timer

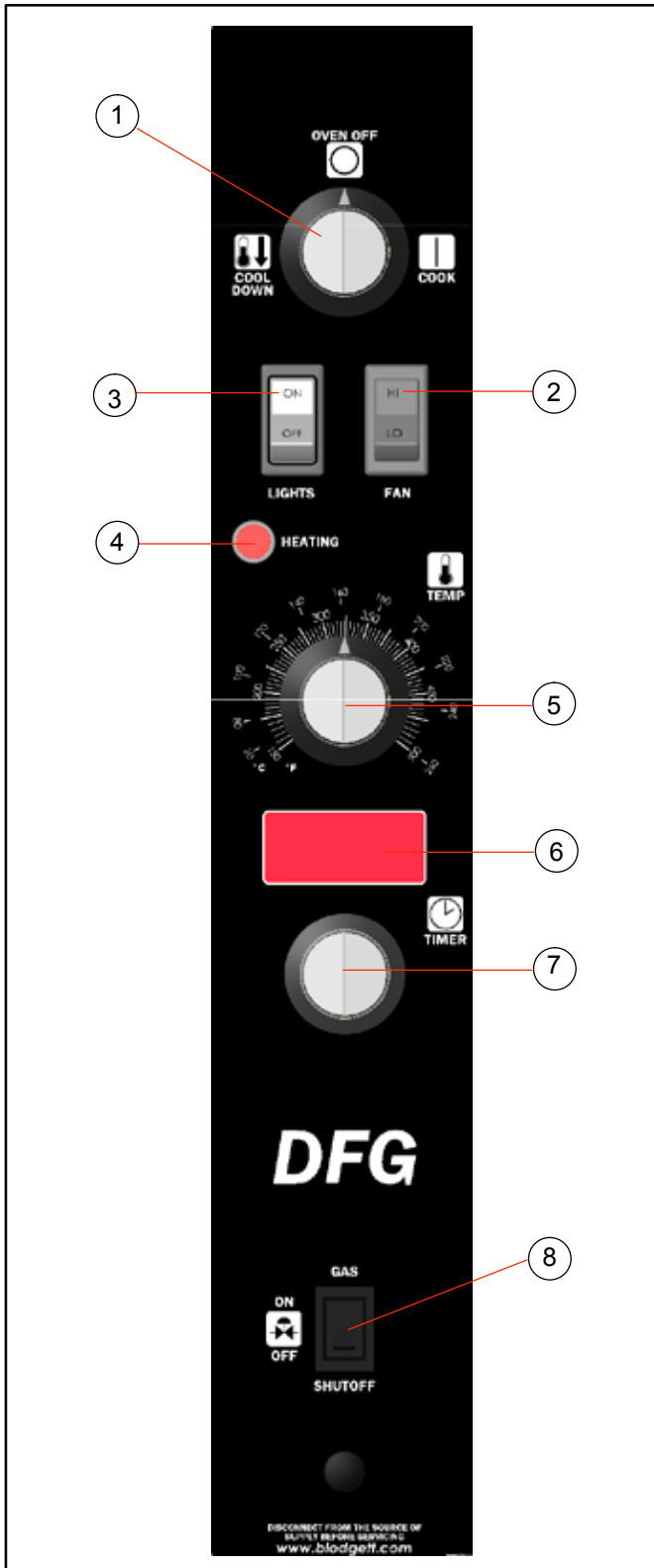

Figure 11

CONTROL DESCRIPTION

1. SELECTOR SWITCH - controls power to the oven for cook or cool down.
2. BLOWER SWITCH - controls blower speed, either hi or lo.
3. LIGHTS SWITCH - controls interior lights.
4. HEATING LIGHT - when lit indicates burner operation. When the light goes out the oven has reached operating temperature.
5. SOLID STATE THERMOSTAT - allows an infinite selection of temperatures from 150-500°F (66-260°C).
6. DISPLAY - displays cook time
7. TIMER DIAL - used to enter desired cook time
8. HEAT CUTOFF - used to turn gas on or off.

OPERATION

1. Turn the SELECTOR Switch (1) to COOK. The blower and control compartment cooling fan operate and are controlled automatically by the action of the doors. The display reads 00:00.
2. Set BLOWER Switch (2) to the desired speed.
3. Set the SOLID STATE THERMOSTAT (5) to the desired temperature.
4. Preheat until the HEATING LIGHT (4) goes out.
5. Load product into the oven. Rotate the dial (7) to the desired time. The timer will begin to countdown after approximately 1 second.
6. When the buzzer sounds, remove the product from the oven. Turn the TIMER dial (7) to silence the buzzer.
7. Turn the SELECTOR Switch (1) to OVEN OFF.



WARNING!!

A complete five minute shutdown must be observed before the oven is relighted.

SSI-M Infinite Control w/Manual Timer

CONTROL DESCRIPTION

1. SELECTOR SWITCH - controls power to the oven for cook or cool down.
2. BLOWER SWITCH - controls blower speed, either hi or lo.
3. LIGHTS SWITCH - controls interior lights.
4. HEATING LIGHT - when lit indicates burner operation. When the light goes out the oven has reached operating temperature.
5. SOLID STATE THERMOSTAT - allows either 8 pre-set temperatures to be selected in accordance with customer requirements, or an infinite selection of temperatures from 200-500°F (95-260°C). (infinite control shown)
6. TIMER - activates an electric buzzer that sounds when the cook time expires.

OPERATION

1. Turn the SELECTOR Switch (1) to COOK. The blower and control compartment cooling fan operate and are controlled automatically by the action of the doors.
2. Set BLOWER Switch (2) to the desired speed.
3. Set the SOLID STATE THERMOSTAT (5) to the desired setting or temperature.
4. Preheat until the HEATING LIGHT (4) goes out.
5. Load product into the oven. Determine cook time and set the TIMER (6).
6. When the buzzer sounds, remove the product from the oven. Turn the TIMER knob (6) to OFF to silence the buzzer.
7. Turn the SELECTOR Switch (1) to OVEN OFF.

WARNING!!

A complete five minute shutdown must be observed before the oven is relighted.

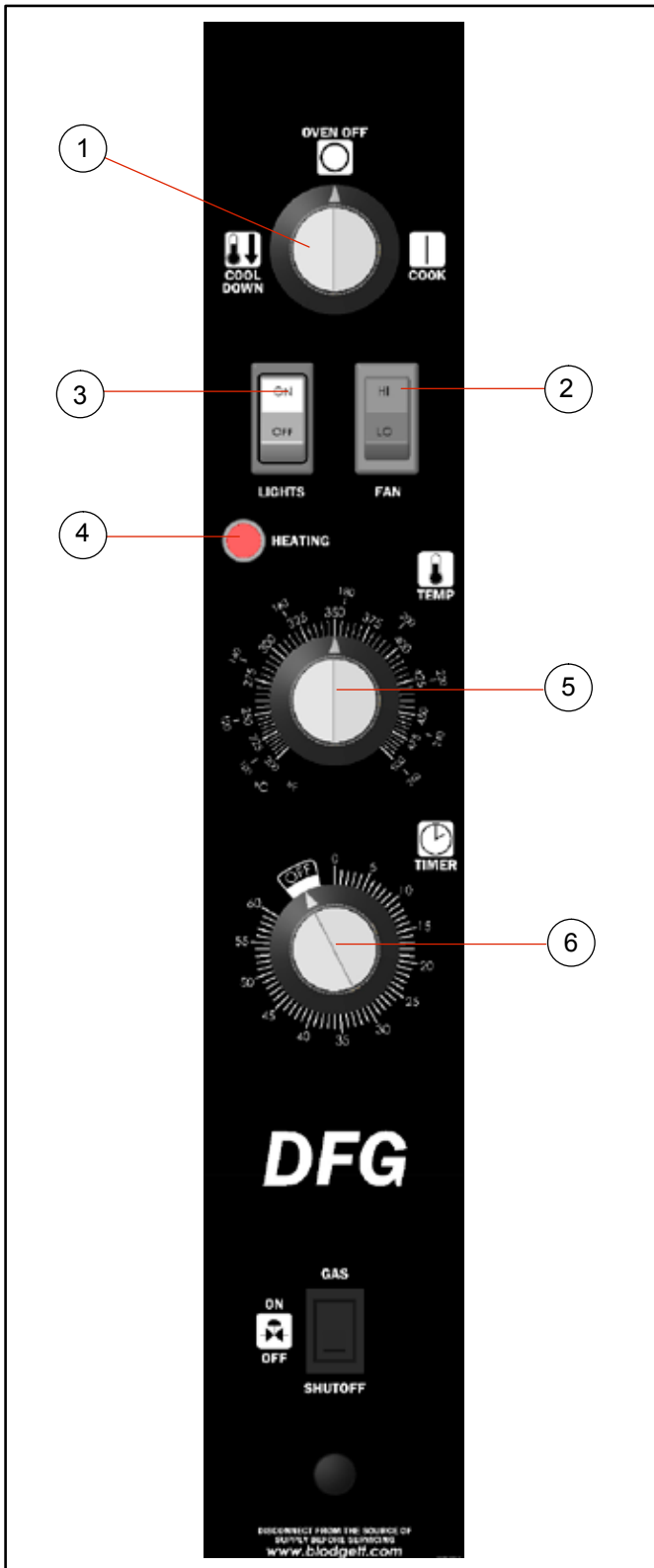
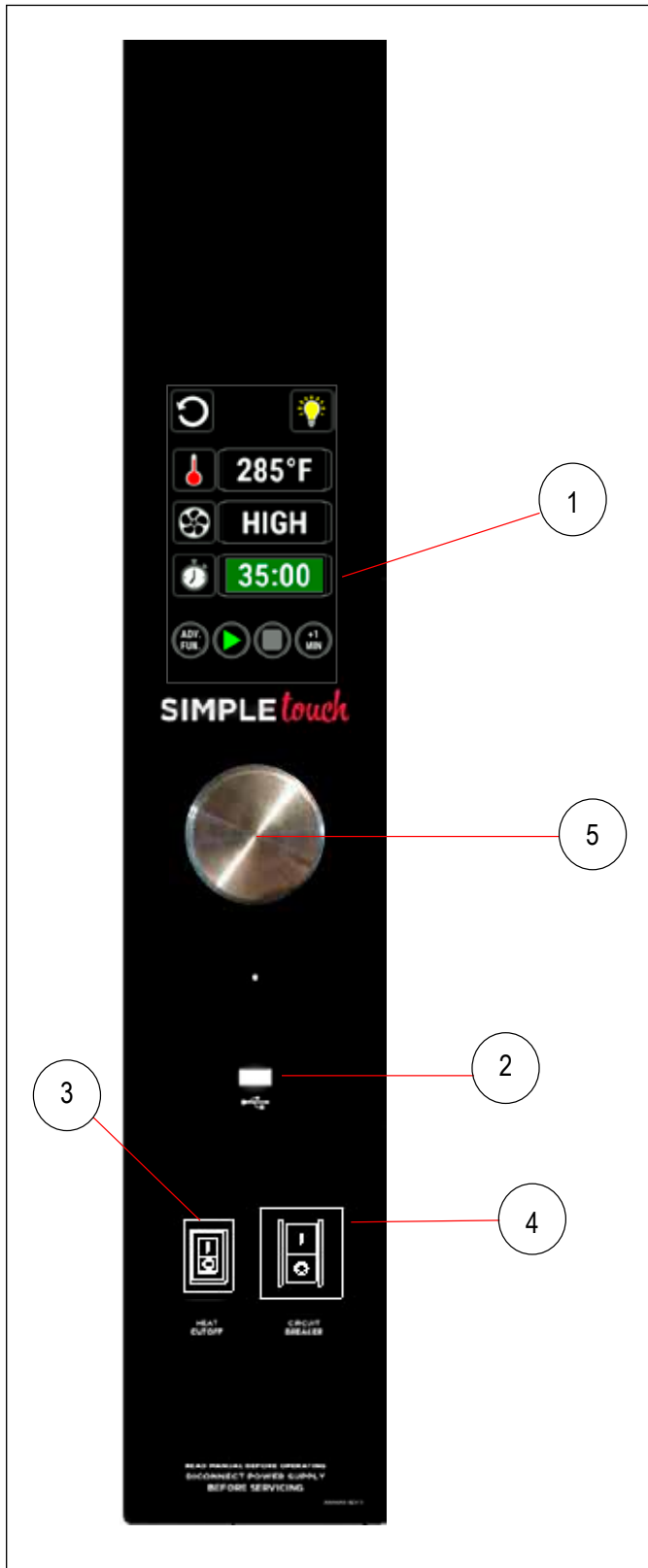

Figure 12



Operation

Simple Touch Control



COMPONENT DESCRIPTION

1. TOUCHSCREEN - Interactive display for oven functioning and/or programming.
2. USB Port - Use to transfer recipes and data to/from the control.
3. HEAT CUTOFF - Used to turn heat source off.
4. CIRCUIT BREAKER – Provides circuit protection for the oven controls. DO NOT use as a power switch.
5. CONTROL KNOB - Used to change values for time, temperature, humidity, etc.

Figure 13

MANUAL MODE COOKING

1. Press POWER to turn on the oven.
2. Press MANUAL to proceed to the manual cook screen.

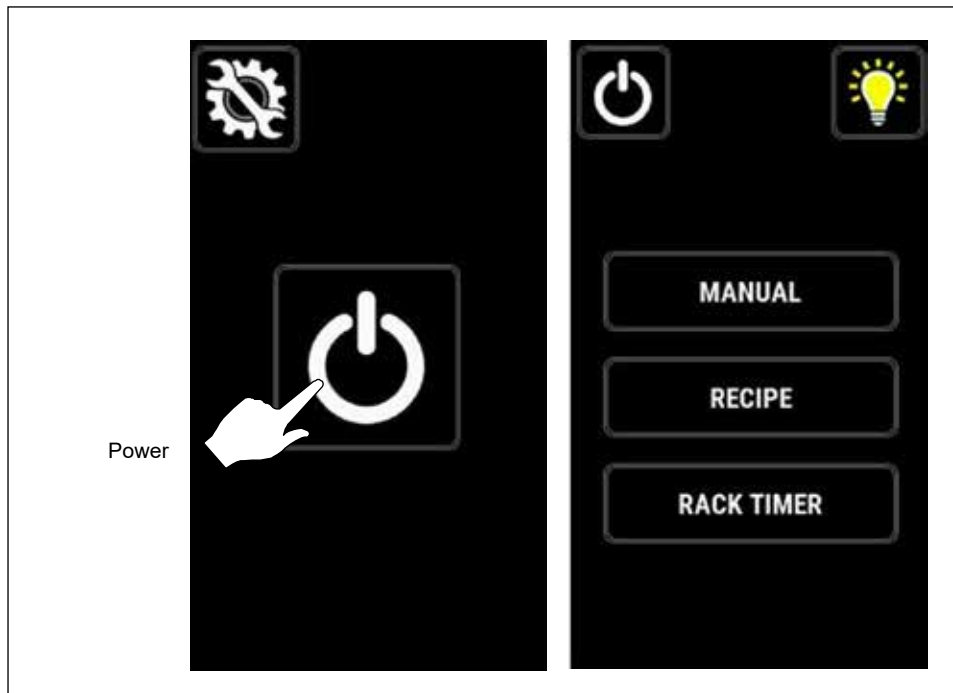

Figure 14



Operation

Simple Touch Control

MANUAL COOK SCREEN

Actual Temp – Press thermometer to display the actual cavity temperature.

Temperature Bar - Press the TEMPERATURE BAR and use the control dial to set the desired oven temperature.

For temperature ranges from minimum to 215°F, the temperature may be set in 1° increments as the knob is turned.

For temperature above 215°F, the temperature may be set in 5° increments.

Press the check mark to save the selection. Press the X to cancel editing without altering current set point value.

Cook Timer - Press the TIMER STATUS BAR and enter the desired cook time using the control dial.

Times greater than 1 hour can be set in 5 minute increments. Times less than 1 hour can be set in 5 second increments.

Press the check mark to save the selection. Press the X to cancel editing without altering current set point value.

Add a Minute - Press +1 MIN to add 1 minute of time at any point during the cook cycle.

Light Activation - Press the LIGHT icon turn the cavity lights on. The icon will change when activated. The lights will remain on until the icon is pressed again by the user OR the timeout period is reached. The default timeout period is 5 minutes.

Fan Speed Bar - Press the FAN SPEED BAR to cycle through the available fan speeds.

Advanced Functions – Press the ADV. FUN icon to access the Fan Pulse, Fan Delay and Cook and Hold functions.

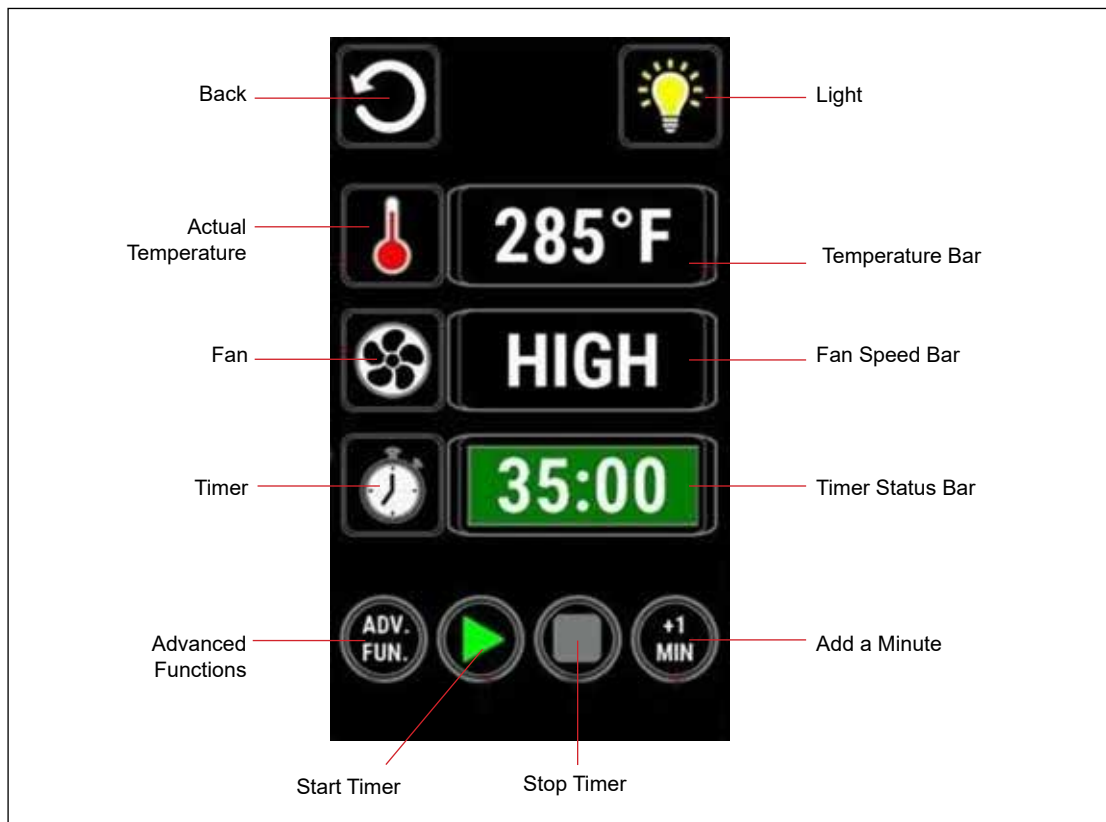

Figure 15

TO OPERATE TIMER

1. Press PLAY to initiate timer. The timer counts down.,
The play button changes to pause.

Press the PAUSE button to stop the timer at current value. The pause button changes back to play. Press play to resume timer.

Press the STOP key to clear the timer.

The +1 MIN key may be selected at any time to add an additional minute to the current timer.

Timer Status Bar

The color of the timer bar represents a percentage of original set time.

- GREEN: 50-100% of the time remains
- ORANGE: 25-49% of the time remains
- RED: 0-24% is indicated by Red

2. When the timer reaches zero, an audible alarm is triggered.

NOTE: The timer stops when the door is opened and resumes when the door is closed.

LIGHT ACTIVATION

Press the LIGHT key to turn on the cavity lights. The icon turns yellow when activated. The key/relay will remain active until pressed again OR the 5 minute default timeout period is reached.

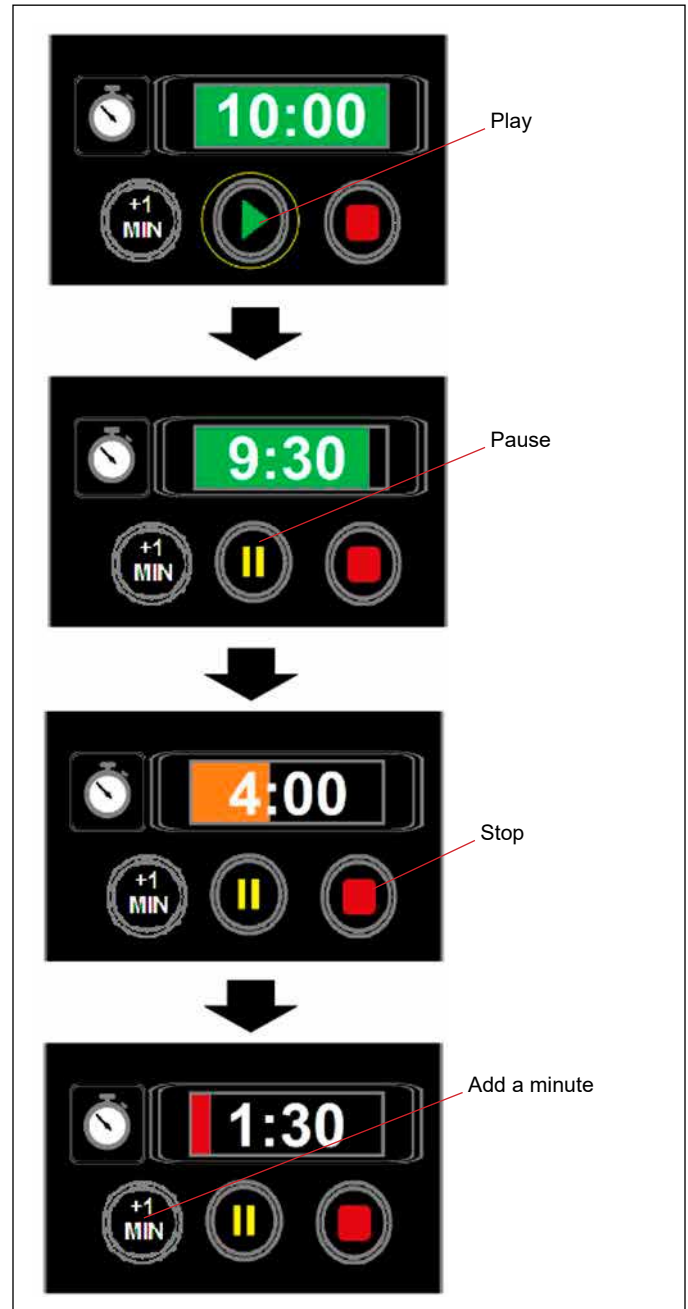

Figure 16

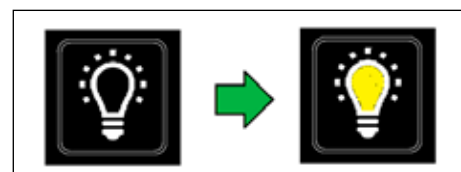

Figure 17



Operation

Simple Touch Control

ADVANCED FUNCTIONS

Cook & Hold

The intent of Cook & Hold is to keep the product at a food safe temperature while not overcooking. Once the cook cycle is complete, the oven automatically switches to the hold time and temperature.

1. From the MANUAL COOK SCREEN, press the ADV. FUN icon.
2. Press the COOK & HOLD key. Four settings bars appear: cook temp, cook time, hold temp and hold time.
3. Use the keypad to enter desired cook and hold time and temperature settings.
4. Press the BACK key to return to the manual cook screen.
 - The C & H icon will replace the timer icon.
 - The timer bar will show the cumulative time of the cook and hold. The cook time will be shaded.
 - If the current set point differs from the Cook & Hold set point, it will change upon returning to the manual operation screen.
 - Press play to initiate Cook & Hold.
5. When the recipe is complete, the oven will maintain the Hold Temp until a new set temperature has been defined.

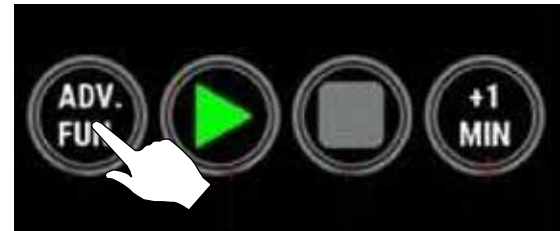

Figure 18

Simple Touch Control

Fan Pulse

1. From the MANUAL COOK SCREEN, press the ADV. FUN icon.
2. Press the FAN PULSE key.

The unit will cycle the fan on and off at the established fan speed over an established pulse duration. The default setting for the fan pulse duration is 30 seconds on / 30 seconds off.

NOTE: When using fan pulse the oven will only be able to heat when fan is operating at set speed.

3. Standard operation resumes when the fan pulse duration has elapsed.

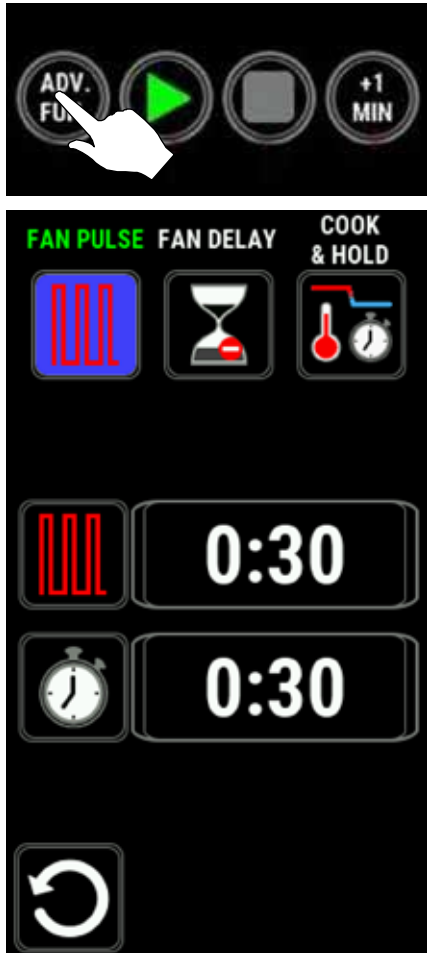

Figure 19

Fan Delay

This feature delays the set fan speed to reduce pulling liquid batters at the beginning of the bake cycle. The fan resumes the set speed after the delay time has expired.

1. From the MANUAL COOK SCREEN, press the ADV. FUN icon.
2. Press the FAN DELAY key.

NOTE: When using fan delay the oven will only be able to heat when fan is operating at set speed.

3. Standard operation resumes when the fan delay duration has elapsed.

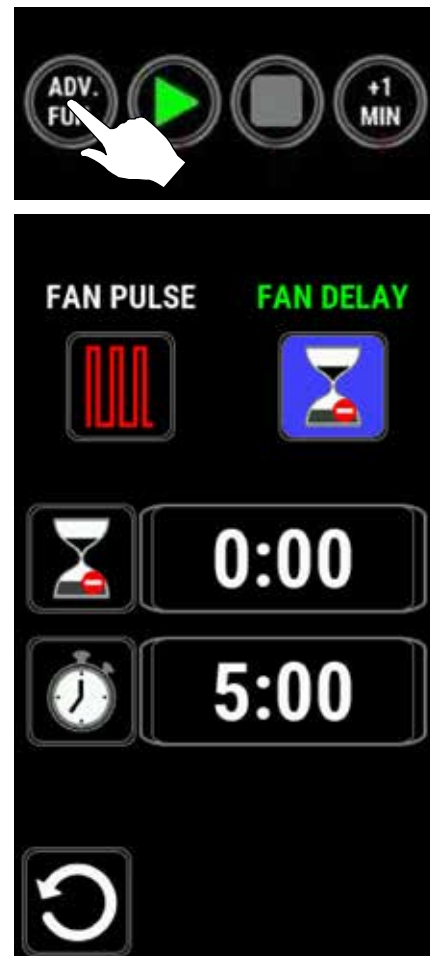

Figure 20



Operation

Simple Touch Control

MENU MODE

Create a New Recipe

1. Press the service key icon, and then select the MAN-AGE RECIPES icon.

NOTE: In the event of a lockout from MANAGE RE-CEPIES use passcode 6368.



Figure 21

2. Select the Recipe Library icon.

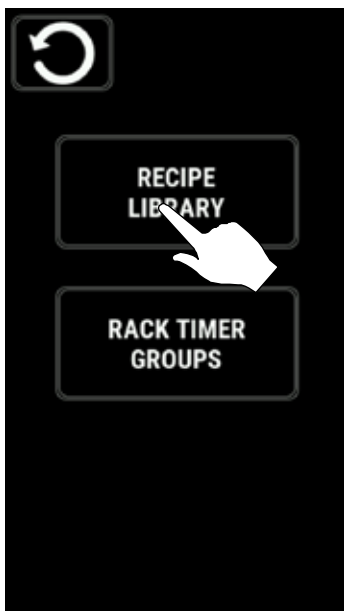

Figure 22

3. Select the ADD icon to add a new recipe



Figure 23

4. Name the recipe then press the green check mark.



Figure 24

Simple Touch Control

- To enter the settings for the first cooking step, select the icon of the variable you wish to edit.

The icon of the selected variable will highlight in blue and the value in the currently selected stage will highlight in yellow.

- Use the knob to adjust the value.
 - Select the green check mark to confirm the selection.
- Press the + to add a step. Press the X to delete the selected step. Use the knob to scroll through recipe stages.
 - Select the disk icon to save the settings, and return to library menu.

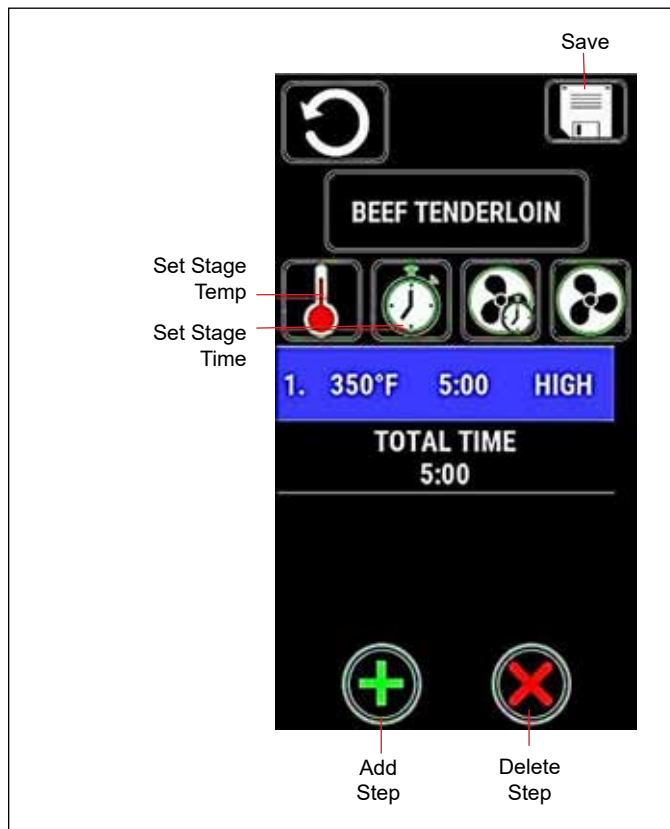

Figure 25

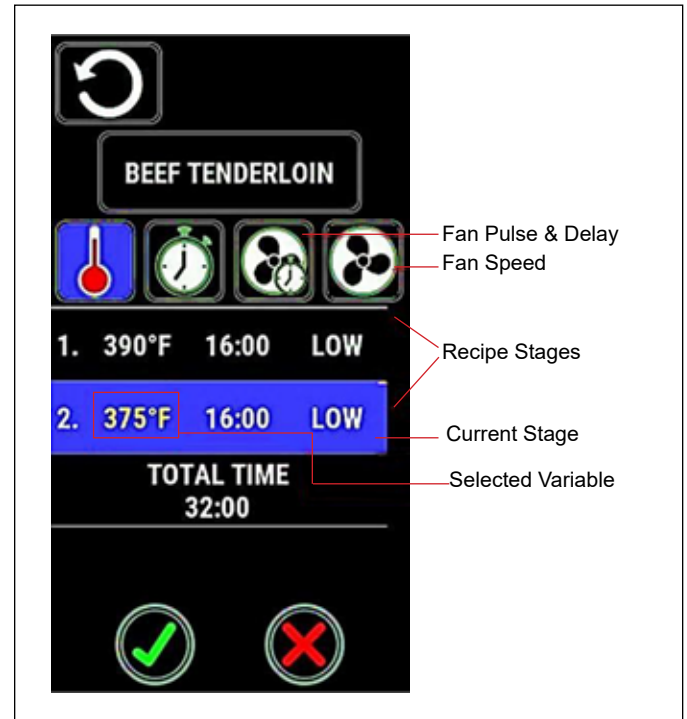

Figure 26

- To edit, copy or delete a recipe select the appropriate the icon called out below.

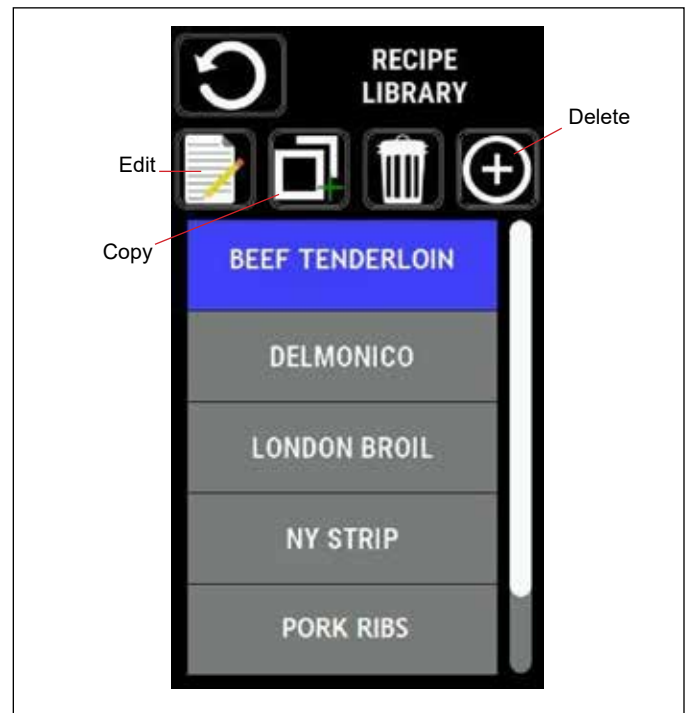

Figure 27



Operation

Simple Touch Control

MENU MODE COOKING

1. Press the power key then select the RECIPE icon.

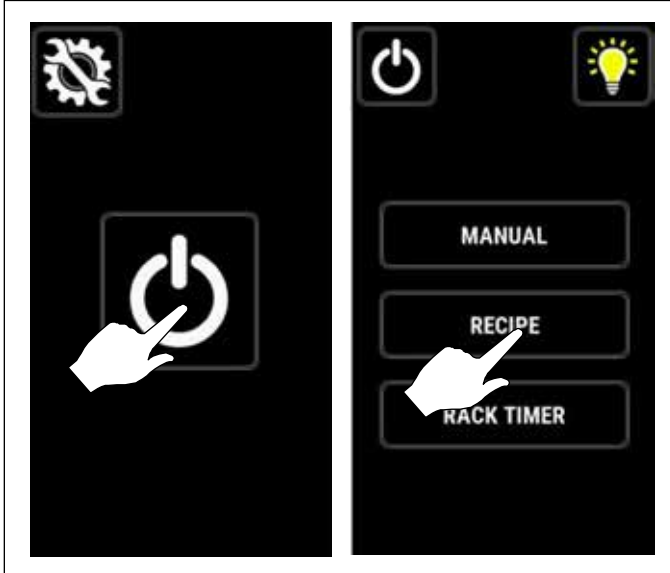

Figure 28

2. Use the knob to scroll through the listed recipes. Select the desired recipe.

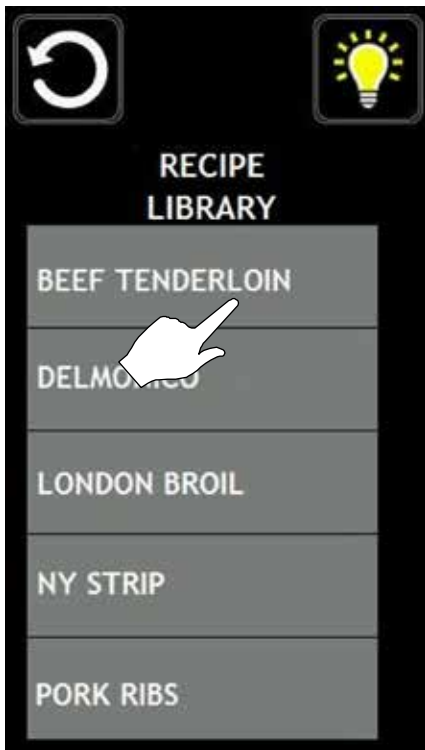

Figure 29

3. The control enters the Menu Cooking screen. Press the START ICON to begin the cook cycle.



NOTE: If lockout is enabled START will not be selectable until the oven has reached the programmed set temperature.

NOTE: The settings between the blue lines indicate the current stage.

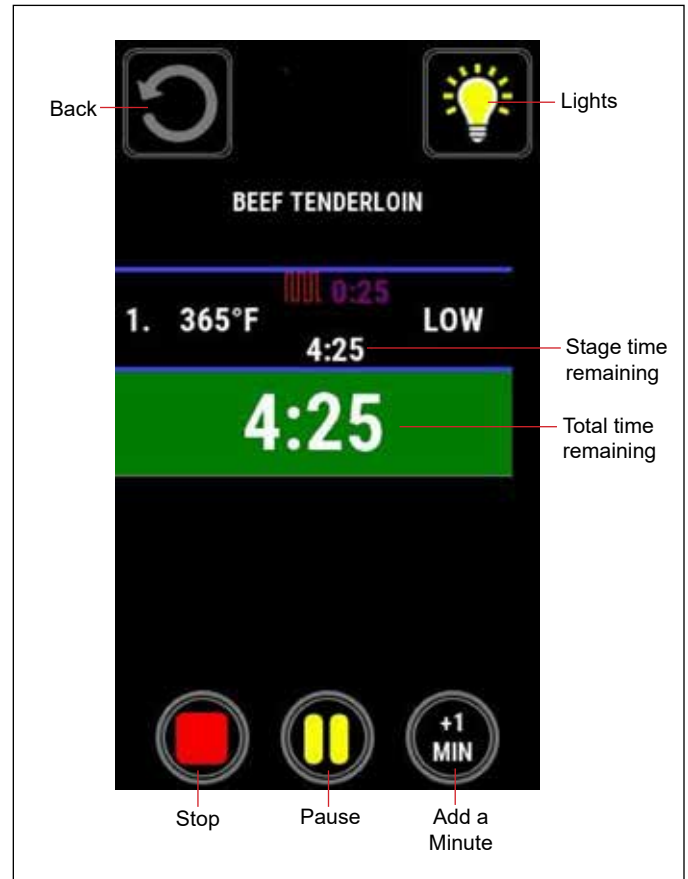

Figure 30

4. Add a Minute, pause and stop can be accessed at any time.
5. When the cook time has expired, the display flashes DONE and the alarm sounds. Press STOP to silence the alarm. The control returns to the recipe cook screen.
6. Press BACK to exit out of MENU mode.

Simple Touch Control

RACK TIMING

Creating a Rack Timing Group

1. Press the service icon, and then select the MANAGE RECIPES icon.

NOTE: In the event of a lockout from MANAGE RECIPES use passcode 6368.

2. Select RACK TIMER GROUPS. The RACK TIMER GROUPS screen is displayed.
3. Select ADD.
4. Use the keypad to name the group. Select the green check mark to save the name.

5. Select the recipes you would like to place in the group.

The first selected recipe will define the group parameters. Clicking a non-greyed recipe will associate it with the group. Only recipes with parameters matching the group may be selected. Recipes with parameters that fall outside group settings or have multiple stages will be greyed. Recipes associated to the group will have a check mark. Up to 12 recipes can be grouped.

6. Once you have finished selecting the recipes desired for your group, press save.

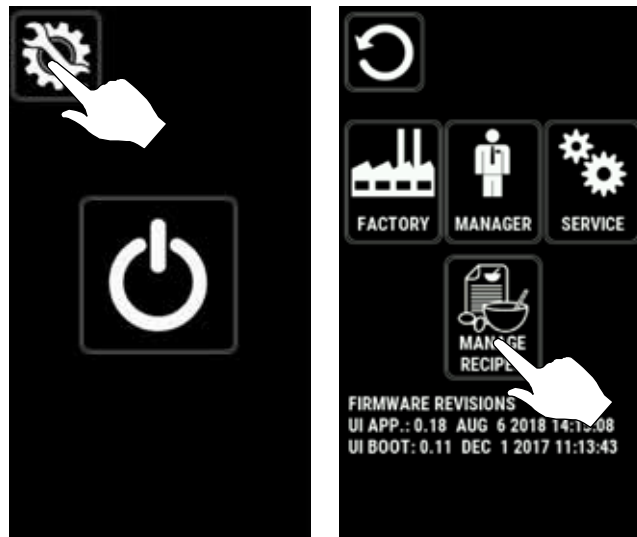



Operation

Simple Touch Control

RACKTIMER COOKING

1. From the mode selection screen, select RACK TIMING. The RACK TIMER GROUPS screen is displayed.



Figure 31

2. Select the desired recipe group. The preheat screen appears.

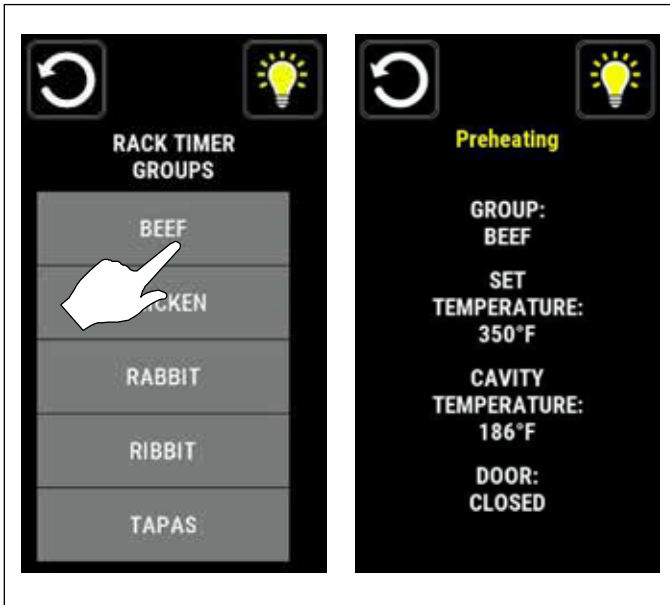

Figure 32

3. When the oven has preheated to the group set temp, the display changes to the RACK TIMING cook screen.

4. Turn the knob to cycle through the group recipes (left and right). The currently selected recipe is in highlighted in blue. The next available recipe in either direction is previewed in smaller recipe boxes to either side.
5. Select the area to the right of the rack number to assign currently highlighted recipe to that rack.

Start and cancel keys are to the right of timer bar when timer is inactive.

+1 min and stop keys are to the right of timer bar when timer is active or done.



Figure 33

Simple Touch Control

TO STORE AND LOAD MENU DATA TO A USB

NOTE: The following procedure may be used to store any type of data to a USB including HACCP, settings and fault logs.

NOTE: **Importing** - you will be given the option to select the desired recipe file on the USB drive. Once a recipe set has been selected you will be given the option to overwrite the existing recipe file with those on the USB or append them to the current recipe library.

Exporting – you will be prompted to name the recipe library being exported.

1. Press the SERVICE KEY.



Figure 34

2. Press the manager icon and enter passcode 6647.

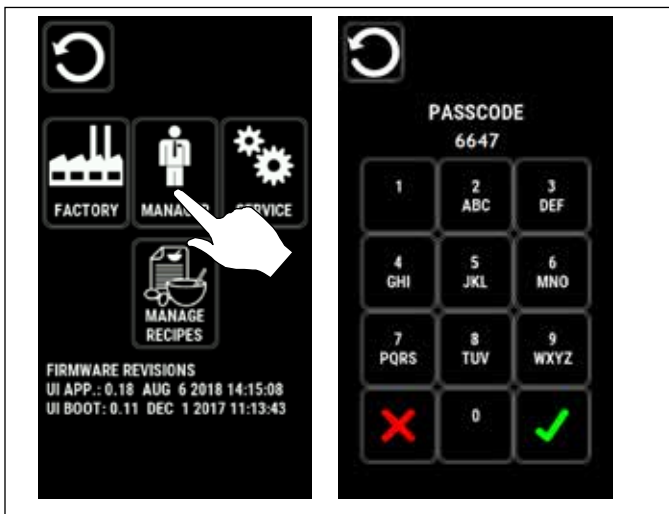

Figure 35

3. Select USB from the menu.

NOTE: The USB drive must be in the port.



Figure 36

4. Select LOAD RECIPE FROM USB or STORE RECIPE TO USB, depending on the action you would like to complete.

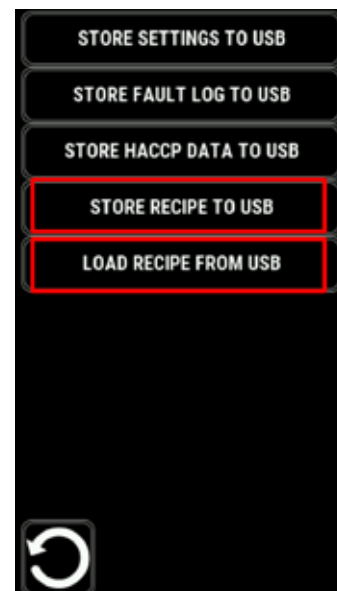

Figure 37



Operation

Simple Touch Control

- To load a recipe from the USB, select LOAD RECIPE FROM USB. Select the recipe file desired for download. The recipe file will highlight in blue when selected. When the selection is complete, press the green checkmark icon.

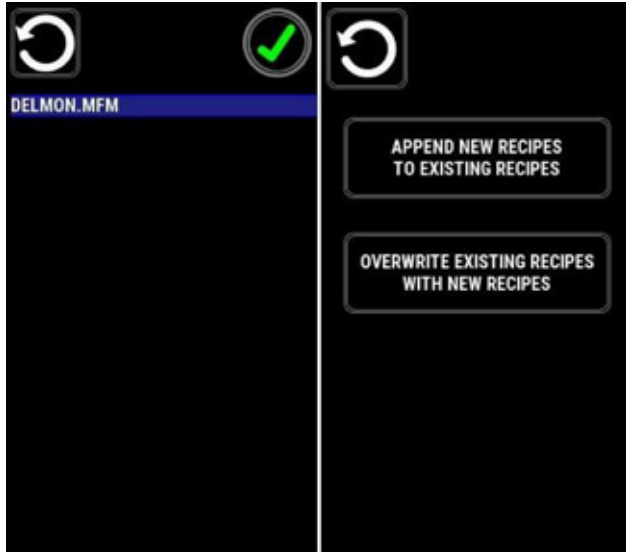

Figure 38

- Select the recipe(s) desired for download. When selected, the recipe(s) will have a blue checkmark next to it. When selection(s) are complete, press the SAVE TO USB icon.

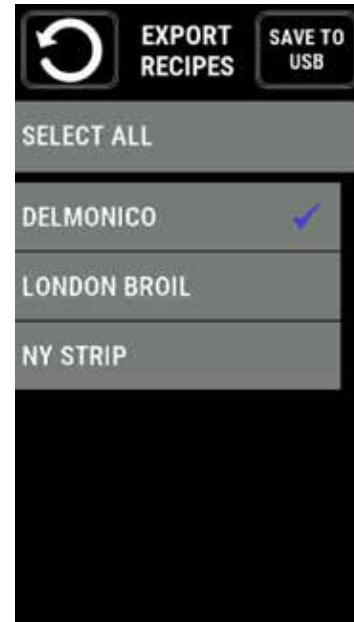

Figure 40

- To store recipe(s) to the USB, select STORE RECIPE TO USB. If desired, select the RACK TIMER groups you wish to export, when selected they will have a blue check mark. Then select CONTINUE TO RECIPES.



Figure 39

- Create a name for the recipe file. When complete, press the green checkmark icon.



Figure 41

COOL DOWN

1. Press the POWER KEY. The display will ask if you would like to cool down prior to shut down.

If the green check mark is selected - the display changes to a power screen with a prompt to have the door open. The control also displays the current cavity temperature.

The fan runs in high speed. When the cool down temperature is reached an alarm sounds and the cavity temperature and door message are removed. All functions will cease as in standard shut down.

If the red X is selected - the display immediately returns to the standard power screen and all functions cease.

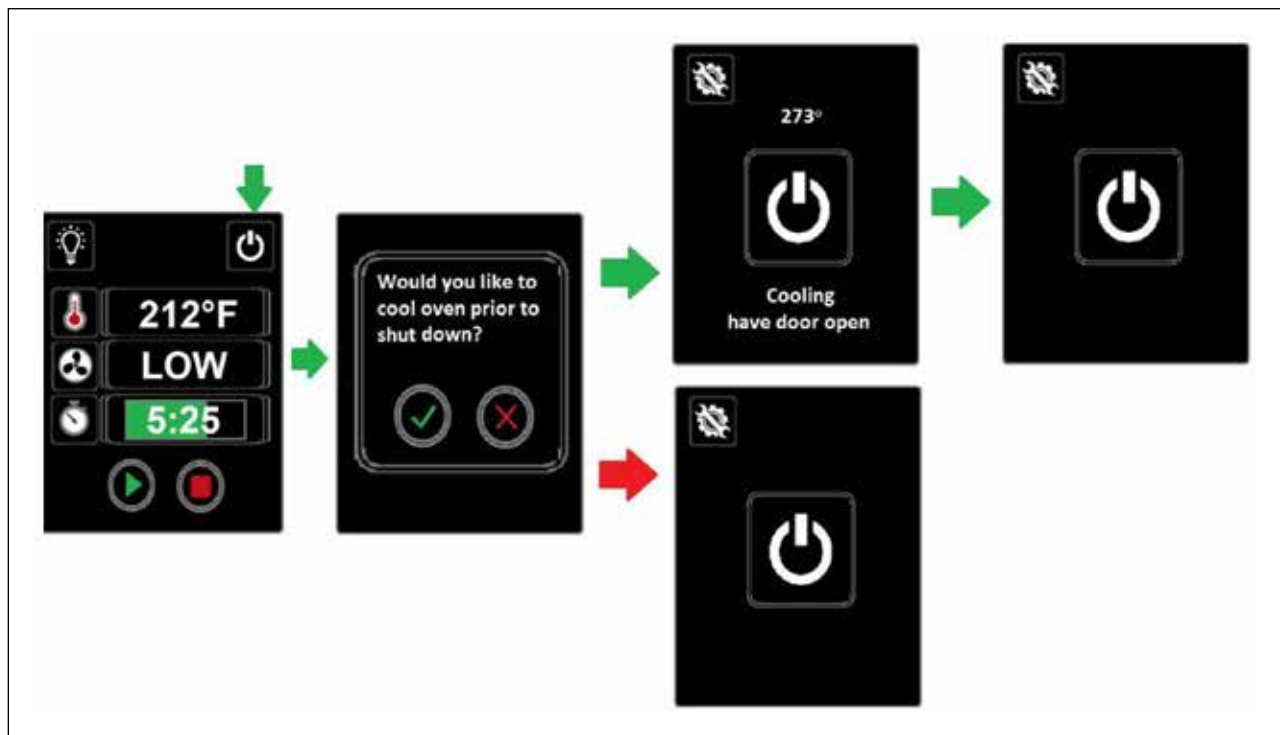

Figure 42



Operation

How Cook & Hold Works

With the optional COOK & HOLD feature, meat is roasted at lower temperatures for longer periods of time. This preserves flavor and tenderness and prevents over drying. There are three phases in cook and hold roasting.

- Primary Cooking - controlled by the COOK & HOLD TIMER. The meat is cooked at a low temperature until approximately 2/3 done.
- Cooking from Stored Heat - when the primary cook time expires, the oven automatically switches to HOLD. The product continues to cook from the heat stored in the oven. Meat must remain in the hold cycle for a minimum of 1-1/2 to 2 hours before being served.
- Hold - holds the product for several hours before serving without loss of moisture or tenderness.

All meat should be completely thawed by refrigeration. Using frozen meat increases the cook time causing shrinkage.

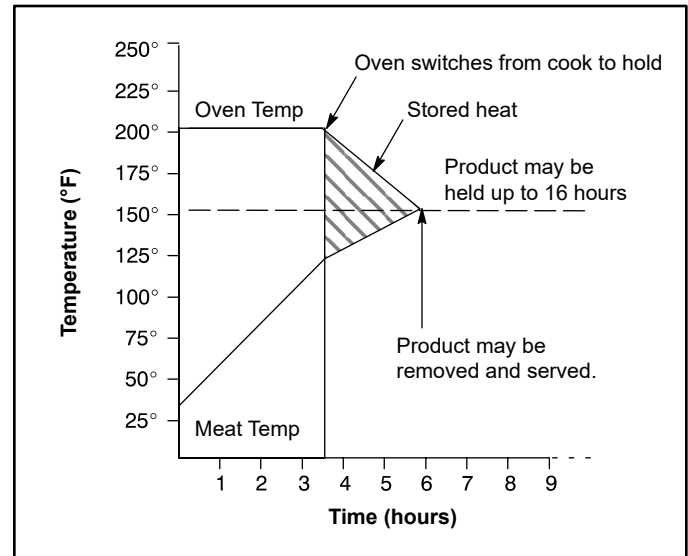

Figure 43

PRODUCT	COOK TEMP.	HOLDTEMP.	QUANTITY	COOK TIME (HRS)	MIN. HOLD TIME (HRS)	TOTAL TIME (HRS)
Prime rib, bone cap off 14-18 lbs. (6.4-8.1 kg)	200°F	140°F	1	3	1	4
	93°C	60°C	3	3-1/4	1-1/2	4-3/4
			6	3-1/2	2	5-1/2
Prime rib, bone cap on 14-18 lbs. (6.4-8.1 kg)	200°F	140°F	1	3-1/2	1	4-1/2
	93°C	60°C	3	4	1-1/2	5-1/2
			6	4-1/2	2	6-1/2
Top or bottom rounds 20-22 lbs. (9.1-10.0 kg)	200°F	140°F	1	3-1/2	1	4-1/2
	93°C	60°C	3	4	1-1/2	5-1/2
			6	4-1/2	2	6-1/2
Pork roast or ham 10-12 lbs. (4.5-5.4 kg)	250°F	170°F	2	4	1	5
	121°C	76°C	4	4-1/4	1-1/2	5-3/4
			6	4-1/2	2	6-1/2
Turkey 20-22 lbs. (9.1-10.0 kg)	250°F	170°F	1	3-1/4	1	4-3/4
	121°C	76°C	6	4	1-1/2	5-1/2
Leg of Lamb, bone in 8-10 lbs. (4.36-4.5 kg)	225°F	160°F	2	2-1/2	1	3-1/2
	107°C	71°C	4	2-3/4	1-1/2	4-1/4
			6	3	2	5

General Guidelines for Operating Personnel

COOK TIMES AND TEMPERATURES

Preheating the oven

Always preheat the oven before baking or roasting. We recommend preheating 50°F (28°C) above the cook temperature to offset the drop in temperature when the doors are opened and cold product is loaded into the oven. Set the thermostat to the cook temperature after the product is loaded.

NOTE: For frozen product, preheat the oven 100°F (56°C) above the cook temperature.

Cook Temperatures

Generally, cook temperatures should be 50°F (28°C) lower than deck or range oven recipes. If the edges of the product are done but the center is raw, or if there is color variation, reduce the thermostat setting another 15-25°F (10-15°C). Continue to reduce the cook temperature on successive loads until the desired results are achieved.

NOTE: Cooking at excessive temperatures will not reduce cook time, it will produce unsatisfactory baking and roasting results.

Cook Time

Check the product in about half the time recommended for deck or range oven recipes. Record times and temperatures which provide best results for future reference.

NOTE: Cook time will vary with the amount of product loaded, the type of pan and the temperature.

OPERATING TIPS

Pans and Racks

Product or pan height determines how many racks are used. The oven holds up to ten 18" x 26" (45.7 x 66.0 cm) bun pans.

Load the oven from the bottom, centering the pans on the rack. Never place a pan or aluminum foil on the bottom of the oven. This obstructs the flow of air and results in uneven baking and roasting.

Roasting

To reduce shrinkage when roasting, place meat directly on the racks. Place a sheet pan one-half full of water in the bottom rack position. The water evaporates, increasing humidity in the oven chamber. The pan catches grease from the meat, making oven cleaning easier.

Baking

Weigh the product to ensure equal distribution in each pan. Varying amounts of product will cause uneven baking results.

Fans

The fan must be operating for the oven to heat. Use the Pulse Plus feature to allow light or liquid product to set in the pan and to avoid rippling towards the fan. If your oven is not equipped with this feature use the following procedure.

1. Preheat the oven 25°F (15°C) above the baking temperature.
2. Load the oven with product. Close the doors.
3. Set the thermostat to the baking temperature.
4. Turn the oven off.
5. Allow the product to set for 5-7 minutes with the fan off. The residual heat in the oven sets the product.
6. Turn the oven on for the remainder of the bake.

Lights

Turn the oven lights off when not viewing the product. Leaving the lights on for extended periods of time shortens the bulb life considerably.



Operation

Suggested Times and Temperatures

PRODUCT	TEMPERATURE	TIME	# SHELVES
Meats			
Hamburger Patties (5 per lb)	400°F (205°C)	8-10 mins.	10
Steamship Round (80 lb. quartered)	275°F (135°C)	2 hrs 45 mins.	2
Standing Rib Choice (20 lbs, trimmed, rare)	235°F (115°C)	2 hrs 45 mins.	2
Banquet Shell Steaks (10 oz. meat)	450°F (235°C)	7-8 mins.	5
Swiss Steak after Braising	275°F (135°C)	1 hr.	5
Baked Stuffed Pork Chop	375°F (190°C)	25-30 mins.	5
Boned Veal Roast (15 lbs.)	300°F (150°C)	3 hrs. 10 mins.	2
Lamb Chops (small loin)	400°F (205°C)	7-8 mins.	5
Bacon (on racks in 18" x 26" pans)	400°F (205°C)	5-7 mins.	10
Poultry			
Chicken Breast & Thigh	350°F (175°C)	40 mins.	5
Chicken Back & Wing	350°F (175°C)	35 mins.	5
Chicken (21/2 lbs. quartered)	350°F (175°C)	30 mins.	5
Turkey Rolled (18 lb. rolls)	310°F (155°C)	3 hrs 45 mins.	3
Fish and Seafood			
Halibut Steaks, Cod Fish (frozen 5 oz)	350°F (175°C)	20 mins.	5
Baked Stuffed Lobster (21/2 lb.)	400°F (205°C)	10 mins.	3
Lobster Tails (frozen)	425°F (220°C)	9 mins.	5
Cheese			
Macaroni & Cheese Casserole	350°F (175°C)	30 mins.	5
Melted Cheese Sandwiches	400°F (205°C)	8 mins.	10
Potatoes			
Idaho Potatoes (120 ct.)	400°F (205°C)	50 mins.	5
Oven Roasted Potatoes (sliced or diced)	325°F (165°C)	10 mins.	5
Baked Goods			
Frozen Berry Pies (22 oz)	325°F (150°C)	35 mins.	5 (30 pies)
Fresh Apple Pie (20 oz.)	350°F (175°C)	25-30 mins.	5 (30 pies)
Pumpkin Pies (32 oz.)	300°F (150°C)	30-50 mins.	5 (20 pies)
Fruit Crisp	300°F (150°C)	25 mins.	5
Bread (24 - 1 lb. loaves)	325°F (155°C)	30 mins.	3
Southern Corn Bread	375°F (190°C)	15-20 mins.	5
Baking Soda Biscuits	400°F (205°C)	6 mins.	5
Brown & Serve Rolls	350°F (175°C)	15 mins.	5
Sheet Cakes (5 lb. mixed batter per pan)	325°F (160°C)	16-18 mins.	5
Chocolate Cake	325°F (160°C)	20 mins.	5
Brownies	325°F (150°C)	15 mins.	5

NOTE: Actual times and temperatures may vary considerably from those shown above. They are affected by weight of load, temperature of the product, recipe, type of pan and calibration of thermostat. Should your recipe vary, write in your proven time and temperature for ready reference.



Cleaning and Preventative Maintenance

CLEANING THE OVEN

Painted and stainless steel ovens may be kept clean and in good condition with a light oil.

1. Saturate a cloth, and wipe the oven when it is cold.
2. Dry the oven with a clean cloth.

On the stainless front or interiors, deposits of baked on splatter may be removed with any non-toxic industrial stainless steel cleaner. Heat tint and heavy discoloration may be removed with any non-toxic commercial oven cleaner.

1. Apply cleaners when the oven is cold. Always rub with the grain of the metal.

The porcelain interior can be cleaned with any commercial oven cleaner. Be sure caustic cleaning compounds **DO NOT** come in contact with the blower wheel and the aluminized steel panel directly behind it.

1. Remove the oven racks, the left and right side rack supports, the blower wheel cover and blower wheel from the oven.
2. Soak the parts in a solution of ammonia and water.
3. Reinstall after cleaning.

NOTE: If the oven is moved the restraint must be reconnected after the unit is returned to it's regular position.

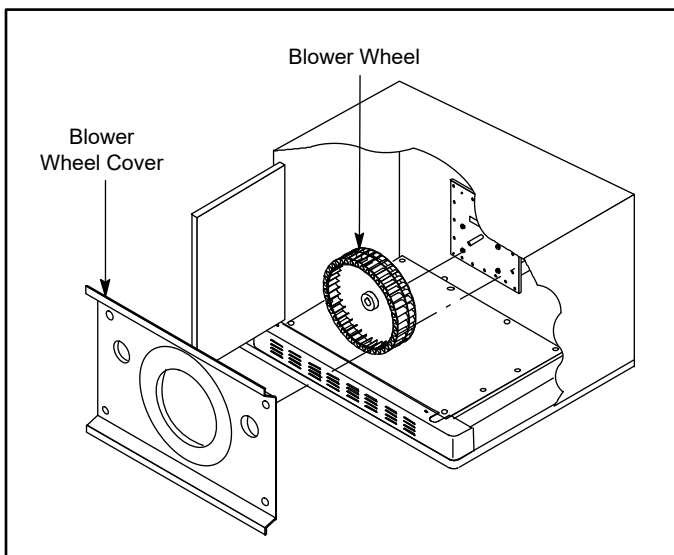

Figure 44

Weekly Cleaning

In addition to the daily cleaning it is necessary to clean the air intakes, such as the blower motor, rear cooling fan and fan guard on a weekly basis. Air intakes provide necessary cooling air to the internal components. They are generally located on the rear and sides of the equipment.

NOTE: If the oven is moved the restraint must be reconnected after the unit is returned to it's regular position.

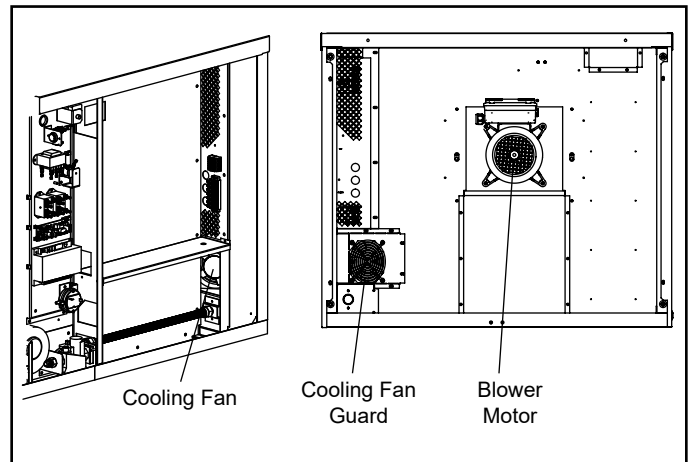

Figure 45

PREVENTATIVE MAINTENANCE

The best preventative maintenance measures are, the proper installation of the equipment and a program for routinely cleaning the ovens.

Annual Maintenance

This oven requires no lubrication, however, the venting system should be checked annually for possible deterioration resulting from moisture and corrosive flue products.

If maintenance or repairs are required, contact your local Blodgett service company, a factory representative or the Blodgett Oven company.



WARNING!!

Always disconnect the appliance from the power supply before servicing or cleaning.



Maintenance

Troubleshooting Guide

POSSIBLE CAUSE(S)	SUGGESTED REMEDY
SYMPTOM: Oven will not fire.	
<ul style="list-style-type: none"> • Gas turned off. • Oven not plugged in. • Power switch on the control panel is off. • Control set below ambient temperature. • Doors are open. • Computerized controls - error code on display. 	<ul style="list-style-type: none"> • Turn the gas valve to ON. • Plug in electrical supply cord. • Set the control panel to COOK or OVEN ON. • Set to desired cook temperature. • Close doors. • *
SYMPTOM: Oven does not come to ready.	
<ul style="list-style-type: none"> • The oven has not reached preheat temperature. • Gas valve not turned on completely. • The quick disconnect is not connected. • Gas pressure to oven is too low. • Fan delay feature may be activated, if applicable. • Internal problem with main temperature control. 	<ul style="list-style-type: none"> • Wait for oven to reach preheat temperature. • Check the gas valve, turn on fully if necessary. • Reconnect the quick connect. Check all gas connections. • Call your local gas representative. • Deactivate fan delay feature. • *
SYMPTOM: Convection fan does not run.	
<ul style="list-style-type: none"> • Oven is not plugged in. • Oven is not set to the cook mode. • Circuit breaker tripped. • Fan delay feature may be activated, if applicable. • Doors are open 	<ul style="list-style-type: none"> • Plug in electrical supply cord. • Set the control panel to COOK or OVEN ON. • Reset the breaker. • Deactivate fan delay feature. • Close doors.
SYMPTOM: General baking problems.	
<ul style="list-style-type: none"> • Computerized controls - incorrect product programming. • Thermostat out of calibration. • Improper oven venting. 	<ul style="list-style-type: none"> • Reprogram control per Operation section. • * • *
<p><i>*Denotes remedy is a difficult operation and should be performed by qualified personnel only. It is recommended, however, that All repairs and/or adjustments be done by your local Blodgett service agency and not by the owner/operator. Blodgett cannot assume responsibility for damage as a result of servicing done by unqualified personnel.</i></p>	

 **WARNING!!**

Always disconnect the power supply before cleaning or servicing the oven.