

BLODGETT® **BLODGETT**® **BLODGETT**® **BLODGETT**®

BLODGETT® **BLODGETT**® **BLODGETT**®

BLODGETT® **BLODGETT**® **BLODGETT**® **BLODGETT**®

BLODGETT®

1060
GAS DECK OVEN
INSTALLATION - OPERATION - MAINTENANCE



BLODGETT OVEN COMPANY

www.blodgett.com

42 Allen Martin Drive, Essex Junction, VT 05452 USA Telephone: (802) 658-6600 Fax: (802)864-0183

PN 17969 Rev N (11/17)

© 2017 - G.S. Blodgett Corporation

Your Service Agency's Address:

Model

Serial number

Oven installed by

Installation checked by

IMPORTANT

WARNING: Improper installation, adjustment, alternation, service or maintenance can cause property damage, injury or death. Read the installation, operation and maintenance instructions thoroughly before installing or servicing this equipment.

INSTRUCTIONS TO BE FOLLOWED IN THE EVENT THE USER SMELLS GAS MUST BE POSTED IN A PROMINENT LOCATION. This information may be obtained by contacting your local gas supplier.

FOR YOUR SAFETY

Do not store or use gasoline or other flammable vapors or liquids in the vicinity of this or any other appliance.

The information contained in this manual is important for the proper installation, use, and maintenance of this oven. Adherence to these procedures and instructions will result in satisfactory baking results and long, trouble free service. Please read this manual carefully and retain it for future reference.

ERRORS: Descriptive, typographic or pictorial errors are subject to correction. Specifications are subject to change without notice.

TABLE OF CONTENTS

INSTALLATION

Oven Description and Specifications	2
Delivery and Location	3
Oven Assembly	4
Packaging	4
Leg Attachment	4
caster attachment	4
Double Section Assembly	5
3 Piece Deflector Assembly	5
Ultra Rokite Shelves	5
Deck Seal	6
Flue Plates	6
Leveling the Oven	6
Adjustments Associated with Initial Installation	6
Ventilation	7
Utility Connections - Standards and Codes	9
Gas Connection	10
Gas Piping	10
Pressure Regulation and Testing	11
Gas Hose Restraint	12
Initial Startup	13

OPERATION

Safety Information	14
Oven Control	15
General Guidelines for Operating Personnel	16

MAINTENANCE

Cleaning and Preventative Maintenance	17
Troubleshooting Guide	18



Installation

Oven Description and Specifications

Blodgett Deck ovens have set industry wide standards of excellence for baking characteristics, performance and reliability. They remain unsurpassed for product quality.

Simplicity of design and quality construction throughout assure years of trouble free service when the equipment is properly installed and maintained.

Features include a full angle iron frame, all welded radius corners and stainless steel fronts and doors.

GAS RATINGS - 1060				
	Natural Gas		Propane	
	US Units	SI Units	US Units	SI Units
Heating Value	1000 BTU/hr	37.3 MJ/m ³	2550 BTU/hr	95.0 MJ/m ³
Specific Gravity (air=1.0)	0.63	0.63	1.53	1.53
Gas Manifold Pressure	3.5" W.C.	0.87 kPa	10" W.C.	2.49 kPa
Oven Input				
Per Burner	42,500 BTU/hr	12.4 kW	42,500 BTU/Hr	12.4 kW
Per Oven	85,000 BTU/Hr	24.9 kW	85,000 BTU/Hr	24.9 kW
Main Burner Orifice Size	30 MTD*	3.3 mm	48 MTD*	1.93 mm
Pilot Burner Orifice Size	.021" Dia.	.53 mm	.0115" Dia.	.29 mm
<i>NOTE: * - Multiple Twist Drill</i>				

Delivery and Location

DELIVERY AND INSPECTION

All Blodgett ovens are shipped in containers to prevent damage. Upon delivery of your new oven:

- Inspect the shipping container for external damage. Any evidence of damage should be noted on the delivery receipt which must be signed by the driver.
- Uncrate the oven and check for internal damage. Carriers will accept claims for concealed damage if notified within fifteen days of delivery and the shipping container is retained for inspection.

The Blodgett Oven Company cannot assume responsibility for loss or damage suffered in transit. The carrier assumed full responsibility for delivery in good order when the shipment was accepted. We are, however, prepared to assist you if filing a claim is necessary.

OVEN LOCATION

The well planned and proper placement of your oven will result in long term operator convenience and satisfactory performance.

The following clearances must be maintained between the oven and any combustible or non-combustible construction.

- Oven body right side - 6" (15 cm)
- Oven body left side - 6" (15 cm)
- Oven body back - 6" (15 cm)
- Oven body bottom - 6" (15 cm)

The following clearance must be available for servicing.

- Oven body left side - 12" (30.5 cm)

NOTE: *On gas models, routine servicing can usually be accomplished within the limited movement provided by the gas hose restraint. If the oven needs to be moved further from the wall, the gas must first be turned off and disconnected from the oven before removing the restraint. Reconnect the restraint after the oven has been returned to its normal position.*

It is essential that an adequate air supply to the oven be maintained to provide a sufficient flow of combustion and ventilation air.

- Place the oven in an area that is free of drafts.
- Keep the oven area free and clear of all combustibles such as paper, cardboard, and flammable liquids and solvents.
- Do not place the oven on a curb base or seal to a wall. This will restrict the flow of air and prevent proper ventilation. Pilot outages or yellow, floating flames on the main burners are indicative of a lack of secondary air.
- The oven must be installed with the legs supplied by the manufacturer.

Before making any utility connections to this oven, check the rating plate to be sure the oven specifications are compatible with the gas and electrical services supplied for the oven.

1. Pull out control panel. The rating plate is attached to the inside of the control compartment.



Installation

Oven Assembly

PACKAGING

Before beginning assembly and installation of the oven, check that all necessary components have been received. In addition to the oven itself, legs, the proper vent, and/or other accessories may be required.

Single Sections

1060 with Steel Deck

- Legs, regulator, set of flue plates, draft diverter and steel deck are shipped in the oven.
- Drafthood (when supplied) is packed separately.

1060 with Ultra Rokite Decks

- Legs, regulator, set of flue plates and draft diverter are shipped in oven.
- Ultra Rokite decks are packed in a separate carton.
- Drafthood (when supplied) is packed separately.

Double Sections

1060 with Steel Deck

- Legs and bolts, regulator, set of flue plates and steel deck are packed in the lower section.
- Regulator, set of flue plates, draft diverter and steel deck are packed in the upper section.
- Crown angle leg frame is packed in a separate carton.
- Drafthood (when supplied) is packed in a separate carton.

1060 with Ultra Rokite Decks

- Legs and bolts, regulator, set of flue plates are packed in the lower section.
- Regulator, draft diverter and a set of flue plates are packed in the upper section.
- Ultra Rokite decks are packed in two separate cartons.
- Crown angle leg frame is packed in a separate carton.
- Drafthood (when supplied) is packed in a separate carton.

LEG ATTACHMENT

1. Put the oven onto a genie lift with the bottom of the oven down. Be careful not to damage the louvered panel under the oven.
2. Each leg is attached by three bolts to the underside of the oven base frame.

CASTER ATTACHMENT

1. Bolt supports to oven with 1/2-13 hex head bolts (casters with brakes should be facing front of oven.)
2. Carefully place oven onto the casters. (It will be necessary to have several persons lift oven off the pallet and set it onto the casters). Engage brakes on front casters.

NOTE: A fixed restraint must be provided if casters are used in conjunction with a flexible connector for movable appliances. This restraint must secure the oven to a non-movable surface to eliminate stress on the connector. If the oven is moved, the restraint must be reconnected after the oven is returned to its normal position.



Oven Assembly

DOUBLE SECTION ASSEMBLY

1. Fasten 12" (305 mm) legs to lower section.
2. Remove the sheet metal flue cover on bottom of UPPER SECTION FLUE ONLY and save the two screws.
3. Fasten crown angle leg frame to upper sections.
4. Insert double oven flue connector into upper oven section flue until it is flush with the base angle. Temporarily hold in place with tape.
5. Install upper section on bottom section.
6. Remove tape and slide flue connector into position over the collar of the bottom section.
7. Fasten flue connector to bottom section with screws from the flue cover.
8. Install drafthood or draft diverter with screws provided.

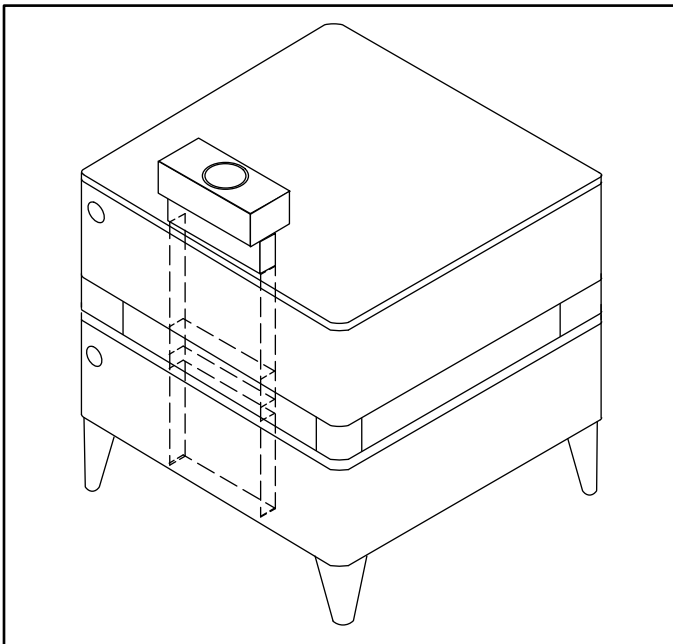

Figure 1

3 PIECE DEFLECTOR ASSEMBLY

1. Deflectors are shipped in place in the oven. No assembly is required.
2. Remove the shipping clip located in the back center of each deflector before inserting two-piece shelf assembly.

ULTRA ROKITE SHELVES

1. Slide the 12" wide Ultra Rokite shelf through the door opening to the rear of the oven until it drops into the shelf support.
2. Slide one of the two 24" wide shelves through the door opening to the rear on the center shelf until it is within the shelf support. Slide all the way to the left until it drops down in place.
3. Slide the other 24" wide shelf through the door opening to the rear on the center shelf until it is within the shelf support. Slide all the way to the right until it drops down in place.
4. Pry the three sections inward so the joints close.
5. Install the deck seal between the door and the frame.

NOTE: Due to the weight of the Ultra Rokite shelves, take care to avoid injury to yourself or damage to the shelves when sliding sections into the oven.



Figure 2



Installation

Oven Assembly

DECK SEAL

1. Place the long lip of the deck seal in front of the shelf support angle. Place the shorter lip with the notches between the shelf support angle and the shelf.
2. Push seal down into place.



Figure 3

FLUE PLATES

1. Insert the back end of the flue plate in the vertical channel in the rear of the oven compartment.
2. Swing the flue plate outward toward the oven side wall.
3. Raise the front end of the flue plate about 1/2". slip the two tabs on the flue plate in the matched angle on the front wall.
4. Drop the flue plate down into place.

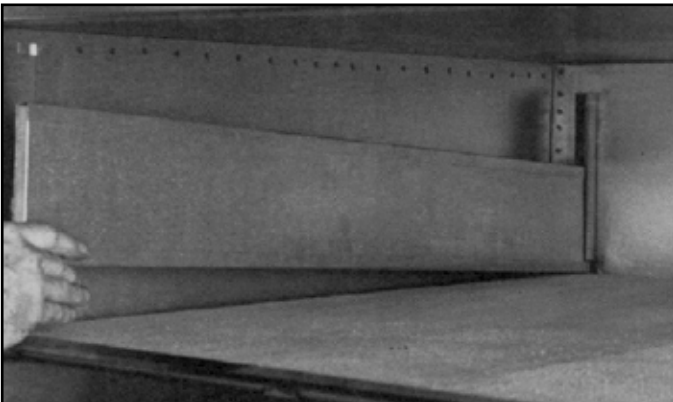

Figure 4

LEVELING THE OVEN

Ovens are equipped with NSF listed adjustable sanitary legs.

1. Level ovens side to side and front to back by placing spirit level on base frame of lower section.
2. Adjust leg feet in or out as appropriate.

ADJUSTMENTS ASSOCIATED WITH INITIAL INSTALLATION

Each oven, and its component parts, have been thoroughly tested and inspected prior to shipment. However, it is often necessary to further test or adjust the oven as part of a normal and proper installation. These adjustments are the responsibility of the installer, or dealer. Since these adjustments are not considered defects in material or workmanship, they are not covered by the Original Equipment Warranty. They include, but are not limited to:

- calibration of the thermostat
- adjustment of the doors
- burner adjustments
- leveling
- testing of gas pressure
- tightening of fasteners

No installation should be considered complete without proper inspection, and if necessary, adjustment by qualified installation or service personnel.

Blodgett gas deck ovens are direct fired. Heat and flue products from the burners are introduced directly into the baking compartment. As a result, improper venting can have a detrimental effect on the baking characteristics of the oven. A properly designed ventilation system will allow the oven to function properly, while removing unwanted vapors and products of combustion from the operating area.

This oven may be vented using either:

- A mechanically driven, canopy type, exhaust hood, or
- A direct flue arrangement.

U.S. and Canadian installations

Refer to your local ventilation codes. In the absence of local codes, refer to the National ventilation code titled, "Standard for the Installation of Equipment for the Removal of Smoke and Grease Laden Vapors from Commercial Cooking Equipment", NFPA-96-Latest Edition.

General export installations

Installation must conform with Local and National installation standards. Local installation codes and/or requirements may vary. If you have any questions regarding the proper installation and/or operation of your Blodgett oven, please contact your local distributor. If you do not have a local distributor, please call the Blodgett Oven Company at 0011-802-658-6600.

The Blodgett Oven Company cannot assume responsibility for loss or damage suffered as a result of improper installation.

WARNING:

Failure to properly vent the oven can be hazardous to the health of the operator and may result in operational problems, unsatisfactory baking and possible damage to the equipment.

Damage sustained as a direct result of improper ventilation will not be covered by the Manufacturer's warranty.

CANOPY TYPE EXHAUST HOOD

A mechanically driven, canopy type exhaust hood is the preferred method of ventilation.

The hood should be sized to completely cover the equipment plus an overhang of at least 6" (15 cm) on all sides not adjacent to a wall. The distance from the floor to the lower edge of the hood should not exceed 7' (2.1m).

The capacity of the hood should be sized appropriately with provisions for an adequate supply of make up air. Capacity is generally expressed in ft³/min (CFM). 1 CFM of natural gas burned with just enough air for complete combustion produces 11 CFM of combustion products. In virtually all appliances some excess air is used. This volume of excess air is added to the flue products flowing from the appliance.

NOTE: Consult your local exhaust hood contractor for your specific installation.

Installing the canopy hood draft diverter

Ovens ordered for hood venting are supplied with a draft diverter. Install the draft diverter as follows:

1. Place the diverter over the flue connector with the open area facing the front of the oven.
2. Secure both ends with the sheet metal screws provided.

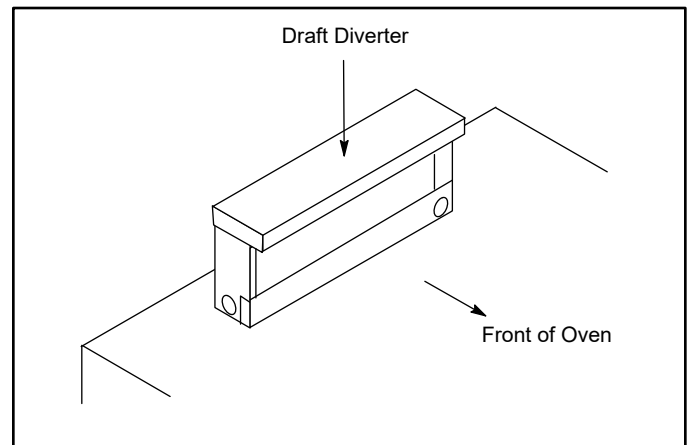

Figure 5



Installation

Ventilation

DIRECT FLUE ARRANGEMENT

When the installation of a mechanically driven exhaust hood is impractical the oven may be vented by a direct flue arrangement.



WARNING!!

It is essential that the direct flue be installed as follows. Incorrect installation will result in unsatisfactory baking and oven damage.

The flue must be class B or better with a diameter of 10" (25.4 cm). The height of the flue should rise 6-8 ft (2-2.5 m) above the roof of the building or any proximate structure. Never direct vent the oven into a hood. The flue should be capped with a UL Listed type vent cap to isolate the unit from external environmental conditions.

The direct vent cannot replace air consumed and vented by the oven. Provisions must be made to supply the room with sufficient make-up air. Total make-up air requirements for each oven section should be approximately 30 CFM per section. To increase the supply air entering the room, a ventilation expert should be consulted.

Installing the draft hood

Ovens ordered for direct venting are supplied with a draft hood. Install the draft hood as follows:

1. Place the draft hood over the flue connector.
2. Secure both ends with the sheet metal screws provided.

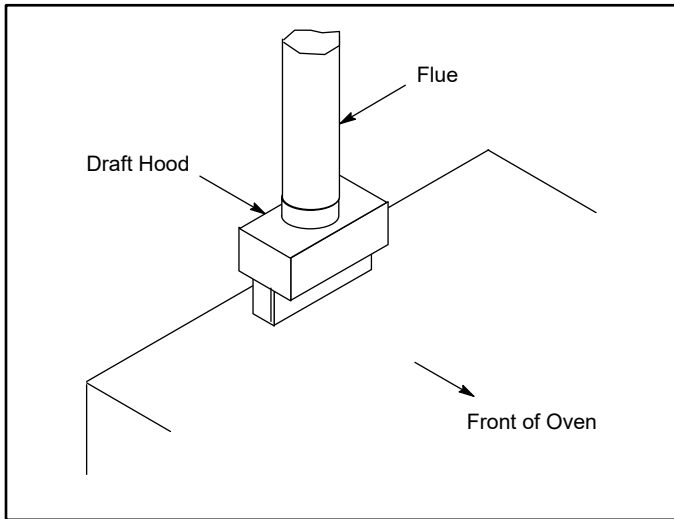

Figure 6

VENTING PROBLEMS

Blodgett gas deck ovens use the natural principal of heat rising as the basic method of ventilation. If the venting of any deck oven is either restricted or forced in any way the baking characteristics of the oven will be adversely affected.

Examples of forced venting include:

- installation of a fan in a direct vent pipe
- use of a canopy type hood without the draft diverter

Examples of restricted venting include:

- use of tees and elbows
- long horizontal runs

Insufficient make-up air can cause heated air and combustibles to remain in the oven shortening the life of the components.

Utility Connections - Standards and Codes

THE INSTALLATION INSTRUCTIONS CONTAINED HEREIN ARE FOR THE USE OF QUALIFIED INSTALLATION AND SERVICE PERSONNEL ONLY. INSTALLATION OR SERVICE BY OTHER THAN QUALIFIED PERSONNEL MAY RESULT IN DAMAGE TO THE OVEN AND/OR INJURY TO THE OPERATOR.

Qualified installation personnel are individuals, a firm, a corporation, or a company which either in person or through a representative are engaged in, and responsible for:

- the installation or replacement of gas piping and the connection, installation, repair or servicing of equipment.

Qualified installation personnel must be experienced in such work, familiar with all precautions required, and have complied with all requirements of state or local authorities having jurisdiction.

U.S. and Canadian installations

Installation must conform with local codes, or in the absence of local codes, with the National Fuel Gas Code, NFPA54/ANSI Z223.1-Latest Edition, the Natural Gas Installation Code CAN/CGA-B149.1 or the Propane Installation Code, CAN/CGA-B149.2 as applicable.

General export installations

Installation must conform with Local and National installation standards. Local installation codes and/or requirements may vary. If you have any questions regarding the proper installation and/or operation of your Blodgett oven, please contact your local distributor. If you do not have a local distributor, please call the Blodgett Oven Company at 0011-802-658-6600.





Installation

Gas Connection

GAS PIPING

A properly sized gas supply system is essential for maximum oven performance. Piping should be sized to provide a supply of gas sufficient to meet the maximum demand of all appliances on the line without loss of pressure at the equipment.

Example:

NOTE: BTU values in the following example are for natural gas.

You purchase a 1060-B deck oven to add to your existing cook line.

1. Add the BTU rating of your current appliances.

Pitco Fryer	120,000 BTU
6 Burner Range	60,000 BTU
Deck Oven	50,000 BTU
Total	230,000 BTU

2. Add the BTU rating of the new oven to the total.

Previous Total	230,000 BTU
1060-B	85,000 BTU
New Total	315,000 BTU

3. Measure the distance from the gas meter to the cook line. This is the pipe length. Let's say the pipe length is 40' (12.2 m) and the pipe size is 1" (2.54 cm).

4. Use the appropriate table to determine the total capacity of your current gas piping.

The total capacity for this example is 320,000 BTU. Since the total required gas pressure, 315,000 BTU is less than 320,000 BTU, the current gas piping will not have to be increased.

NOTE: The BTU capacities given in the tables are for straight pipe lengths only. Any elbows or other fittings will decrease pipe capacities. Contact your local gas supplier if you have any questions.

Maximum Capacity of Iron Pipe in Cubic Feet of Natural Gas Per Hour

(Pressure drop of 0.5 Inch W.C.)

PIPE LENGTH (FT)	NOMINAL SIZE, INCHES				
	3/4"	1"	1-1/4"	1-1/2"	2"
10	360	680	1400	2100	3950
20	250	465	950	1460	2750
30	200	375	770	1180	2200
40	170	320	660	990	1900
50	151	285	580	900	1680
60	138	260	530	810	1520
70	125	240	490	750	1400
80	118	220	460	690	1300
90	110	205	430	650	1220
100	103	195	400	620	1150

From the National Fuel Gas Code Part 10 Table 10-2

Maximum Capacity of Pipe in Thousands of BTU/hr of Undiluted L.P. Gas at 11" W.C.

(Pressure drop of 0.5 Inch W.C.)

PIPE LENGTH (FT)	OUTSIDE DIAMETER, INCHES		
	3/4"	1"	1-1/2"
10	608	1146	3525
20	418	788	2423
30	336	632	1946
40	287	541	1665
50	255	480	1476
60	231	435	1337
70	215	404	1241
80	198	372	1144
90	187	351	1079
100	175	330	1014

From the National Fuel Gas Code Part 10 Table 10-15

PRESSURE REGULATION AND TESTING

Each section of the 1060-B series oven is rated at 85,000 BTU per hour (24.9 kW). At full demand, each section 1060-BL oven requires 85 cubic feet per hour (2.4 m³) Natural gas or 33 cubic feet per hour (0.9 m³) Propane gas. Each oven has been adjusted at the factory to operate with the type of gas specified on the rating plate.

INLET PRESSURE				
	Natural		Propane	
	Min	Max	Min	Max
W.C.	7.0	10.5	11.0	13.0
kPa	1.43	2.61	2.74	3.23
MANIFOLD PRESSURE				
	Natural		Propane	
W.C.	3.5		10.0	
kPa	.87		2.49	

- Inlet Pressure - the pressure of the gas before it reaches the oven.
- Manifold Pressure - the pressure of the gas as it enters the main burner(s).
- Min - the minimum pressure recommended to operate the oven.
- Max - the maximum pressure at which the manufacturer warrants the oven's operation.

Each oven is supplied with a regulator to maintain the proper gas pressure. **The regulator is essential to the proper operation of the oven and must be installed.** It is preset to provide the oven with 3.5" W.C. (0.87 kPa) for natural gas and 10.5" W.C. (2.50 kPa) for Propane at the manifold.

DO NOT INSTALL AN ADDITIONAL REGULATOR WHERE THE OVEN CONNECTS TO THE GAS SUPPLY UNLESS THE SUPPLY EXCEEDS THE MAXIMUM PRESSURE.

Due to the decrease in oxygen at higher elevations, above 2000', the unit may need to be rerated. (The orifice size may need to be adjusted to accommodate different air pressures at higher elevations.) If not rerated, incomplete combustion may occur releasing Aldehydes and CO or Carbon Monoxide. **Any of these are unacceptable and may be hazardous to the health of the operator.**

Prior to connecting the oven, gas lines should be thoroughly purged of all metal filings, shavings, pipe dope, and other debris. After connection, the oven should be checked for correct gas pressure.

Installation must conform with local codes, or in the absence of local codes, with the National Fuel Gas Code, NFPA54/ANSI Z223.1-Latest Edition, the Natural Gas Installation Code CAN/CGA-B149.1 or the Propane Installation Code, CAN/CGA-B149.2 as applicable.

The oven and its individual shutoff valve must be disconnected from the gas supply piping system during any pressure testing of that system at test pressures in excess of 1/2 psig (3.45kPa).

The oven must be isolated from the gas supply piping system by closing its individual manual shutoff valve during any pressure testing of the gas piping system at test pressures equal or less than 1/2 psig (3.45kPa).



Installation

Gas Connection

GAS HOSE RESTRAINT

If the oven is mounted on casters, a commercial flexible connector with a minimum of 3/4" (1.9 cm) inside diameter must be used along with a quick connect device.

The restraint, supplied with the oven, must be used to limit the movement of the unit so that no strain is placed upon the flexible connector. With the restraint fully stretched the connector should be easy to install and quick connect.

The restraint (ie: heavy gauge cable) should be 1,000 lb. (453 kg) test load and should be attached without damaging the building. **DO NOT** use the gas piping or electrical conduit for the attachment of the permanent end of the restraint! Use anchor bolts in concrete or cement block. On wooden walls, drive hi test wood lag screws into the studs of the wall.

1. Mount the supplied bracket to the leg bolt just below the gas inlet.
2. The clip on restraining cable can be attached to the mounting bracket.

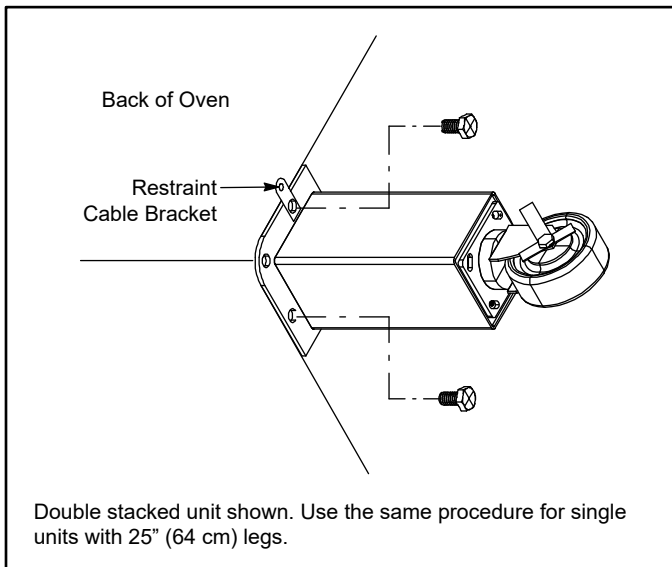

Figure 7



WARNING!!

If the restraint is disconnected for any reason it must be reconnected when the oven is returned to its original position.

U.S. and Canadian installations

The connector must comply with the Standard for Connectors for Movable Gas Appliances, ANSI Z21.69 or Connectors For Moveable Gas Appliances CAN/CGA-6.16 and a quick disconnect device that complies with the Standard for Quick-Disconnect Devices for Use With Gas Fuel, ANSI Z21.41 or Quick Disconnect For Use With Gas Fuel CAN 1-6.9. Adequate means must be provided to limit the movement of the appliance without depending on the connection and the quick disconnect device or its associated piping. Adequate means must be provided to limit the movement of the appliance without depending on the connection and the quick disconnect device or its associated piping.

General export installations

The restraint and quick connect must conform with Local and National installation standards. Local installation codes and/or requirements may vary. If you have any questions regarding the proper installation and/or operation of your Blodgett oven, please contact your local distributor. If you do not have a local distributor, please call the Blodgett Oven Company at 0011-802-658-6600.

ADJUSTMENTS ASSOCIATED WITH INITIAL INSTALLATION

Each oven, and its component parts, have been thoroughly tested and inspected prior to shipment. However, it is often necessary to further test or adjust the oven as part of a normal and proper installation. These adjustments are the responsibility of the installer, or dealer. Since these adjustments are not considered defects in material or workmanship, they are not covered by the Original Equipment Warranty. They include, but are not limited to:

- calibration of the thermostat
- adjustment of the doors
- burner adjustments
- leveling
- testing of gas pressure
- tightening of fasteners

No installation should be considered complete without proper inspection, and if necessary, adjustment by qualified installation or service personnel.



Operation

Safety Information

The information contained in this section is provided for the use of qualified operating personnel. Qualified operating personnel are those who have carefully read the information contained in this manual, are familiar with the functions of the oven and/or have had previous experience with the operation of the equipment described. Adherence to the procedures recommended herein will assure the achievement of optimum performance and long, trouble-free service.

Please take the time to read the following safety and operating instructions. They are the key to the successful operation of your Blodgett oven.



SAFETY TIPS

For your safety read before operating

What to do if you smell gas:

- DO NOT try to light any appliance.
- DO NOT touch any electrical switches.
- Use an exterior phone to call your gas supplier immediately.
- If you cannot reach your gas supplier, call the fire department.

What to do in the event of a power failure:

- Turn all switches to off.
- DO NOT attempt to operate the oven until the power is restored.

NOTE: In the event of a shut-down of any kind, allow a five (5) minute shut off period before attempting to restart the oven.

General safety tips:

- DO NOT use tools to turn off the gas control. If the gas cannot be turned off manually do not try to repair it. Call a qualified service technician.
- If the oven needs to be moved for any reason, the gas must be turned off and disconnected from the unit before removing the restraint cable. Reconnect the restraint after the oven has been returned to its original location.
- DO NOT remove the control panel cover unless the oven is unplugged.

Oven Control

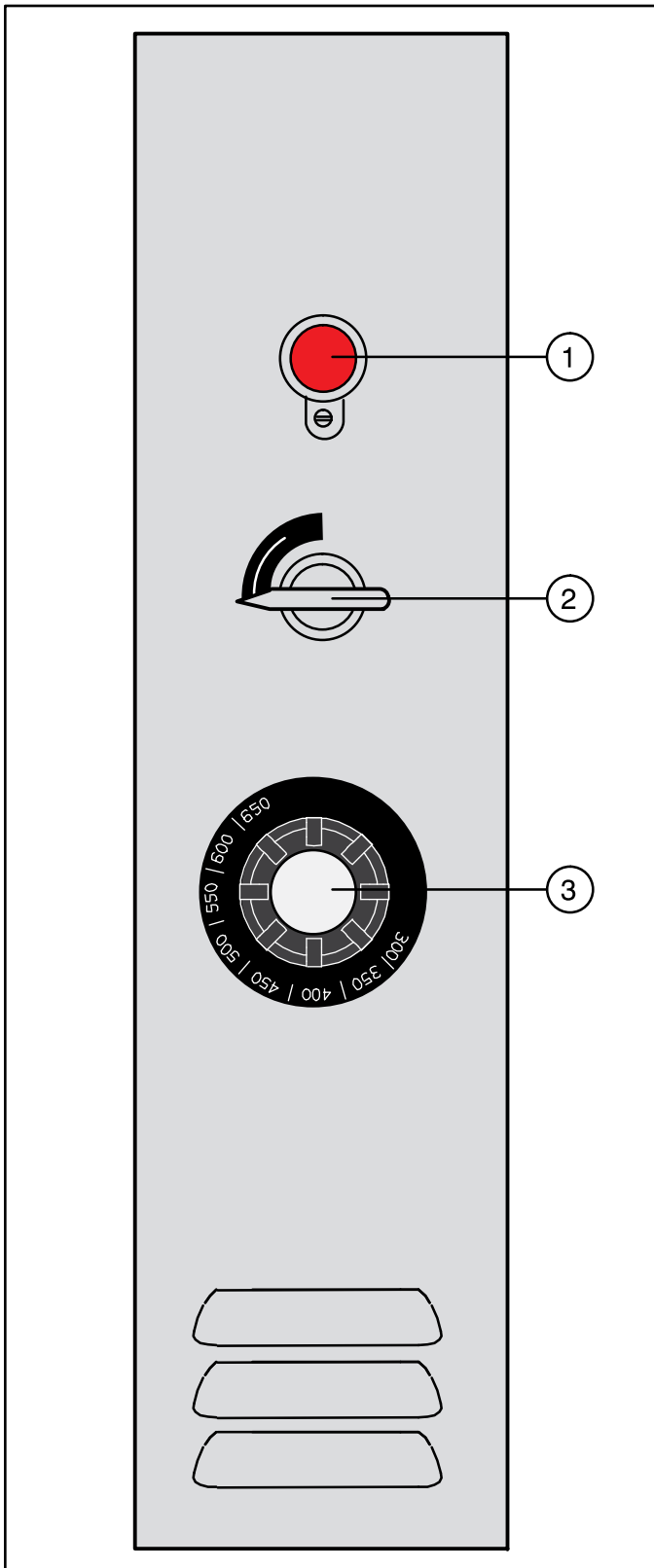

Figure 8

CONTROL DESCRIPTION

1. AUTOMATIC SAFETY PILOT VALVE - provides complete gas shut-off in the event of pilot failure.
2. MANUAL CONTROL VALVE - provides manual control of gas flow to the main burner through the thermostat.
3. THERMOSTAT - Provides regulation of oven temperature at setting selected by the oven operator.

OPERATION

The operation of the 1060 Oven is as simple as 1, 2, 3. - Lighting, Preheating and Loading.

Lighting

1. Turn the manual control valve (2) to OFF.
2. Push the red button on the automatic safety pilot valve (1).
3. Apply a lighted match or taper to pilot burner.
4. After pilot burner lights, continue to depress red button for about 30 seconds and release.
5. Turn the manual control valve (2) to ON.
6. Set THERMOSTAT (3) to desired temperature.

Preheating

1. On initial startup, preheat the oven to 600°F (315°C) over a period of four hours in increments of 100°F (55°C) starting at 300°F (149°C). Check the oven periodically. This will temper the Ultra Rokite shelves and burn off any oil and fiberglass residue.

NOTE: The 1060 (with Ultra Rokite shelves) will require an additional 20 minutes on a preheat to 600°F (315°C).

Loading

Pizza in pans should be placed in rotation on the shelf allowing it to recover its loss of temperature from the previous bake. Do not allow pans to touch each other or sides of oven. Open doors as seldom as possible.

The deck is intended for cooking pizza and bread products, other types of food may be cooked in pans or containers.

To turn the oven off

1. Turn the manual control valve (1) to OFF.

NOTE: When the oven is shut down, place the Main Manual Control Valve in the OFF position. It is not necessary to extinguish the pilot flame.



Operation

General Guidelines for Operating Personnel

COOK TIMES AND TEMPERATURES

Cook Temperatures

Cook temperatures vary with different products. Experiment with the initial bakes until you find the ideal combination of time and temperature.

Example: pizza

1. Run several bakes at 500°F (260°C). Make note of the time required to achieve a firm crust.
2. If the cheese breaks down too quickly or scorches, lower the temperature and lengthen the bake time.
3. If faster production is desired, run additional bakes increasing the temperature by increments of 25°F (15°C).
4. Record the results to determine the highest temperature at which you can bake and achieve quality results with maximum production.

NOTE: Pull time is critical at high temperatures.

Cook Time

Cook times vary with the amount of product loaded, the type of pan and the temperature. Raising the temperature to lower the cook time is effective to a point. Then the quality of the bake begins to suffer.

BAKING TIPS

- Scale dough for consistent product.
- Proof dough to proper consistency.
- Refrigerated dough or pies should be brought to room temperature before baking. Bubbles may occur when baking refrigerated product. Break bubbles if necessary.
- Alternate use between upper and lower section in a double oven.
- Avoid frequent needless opening of the door
- Rotate product placement in the oven.



Cleaning and Preventative Maintenance

CLEANING THE OVEN

Painted and stainless steel ovens may be kept clean and in good condition with a light oil.

1. Saturate a cloth, and wipe the oven when it is cold.
2. Dry the oven with a clean cloth.

On the stainless front or interiors, deposits of baked on splatter may be removed with any non-toxic industrial stainless steel cleaner. Heat tint and heavy discoloration may be removed with any non-toxic commercial oven cleaner.

1. Apply cleaners when the oven is cold, and always rub with the grain of the metal.

Clean Ultra Rokite decks with a triangular scraper used for cleaning broiler grids. **IMPORTANT - DO NOT** use water or any other liquids to clean the deck!

Clean the aluminized interior portion of the oven with a mild detergent. **DO NOT** use caustic solutions such as ammonia, lye or soda ash. **DO NOT** use domestic oven cleaners. Any of these products will damage the aluminum coating.

Daily Cleaning

- Remove residue from beneath the doors with a small broom or brush.

Weekly Cleaning

- Brush out the combustion compartment and control area.
- In addition to the daily cleaning it is necessary to clean the air intakes on a weekly basis. Air intakes provide necessary cooling air to the internal components. They are generally located on the rear and sides of the equipment.

6 Month Cleaning

- Clean secondary air ducts and air entry ports.

NOTE: If the oven is moved the restraint must be reconnected after the unit is returned to its regular position.

PREVENTATIVE MAINTENANCE

The best preventative maintenance measures are, the proper installation of the equipment and a program for routinely cleaning the ovens.

This oven requires no lubrication, however, the venting system should be checked annually for possible deterioration resulting from moisture and corrosive flue products.

If maintenance or repairs are required, contact the factory, the factory representative or a local Blodgett service company.



Maintenance

Troubleshooting Guide

POSSIBLE CAUSE(S)	SUGGESTED REMEDY
SYMPTOM: Strong bottoms on the bakes	
<ul style="list-style-type: none"> • Too much bottom heat • High gas pressure • Faulty flue (strong direct vent) • Product left in the oven too long 	<ul style="list-style-type: none"> • Reduce cook temperature and increase time • * • * • Shorten cook time
SYMPTOM: Uneven bakes	
<ul style="list-style-type: none"> • Poor ventilation • Oven doors left open too long • Improper scaling of dough • Fluctuating gas pressure • Warped pans 	<ul style="list-style-type: none"> • * • Do not open door unnecessarily • Scale dough consistently • * • Change pans
SYMPTOM: Product burning	
<ul style="list-style-type: none"> • Thermostat set too high • Product left in the oven too long • By-pass flame too high • High gas pressure • Thermostat out of calibration • Heat deflectors worn out 	<ul style="list-style-type: none"> • Reduce cook temperature • Shorten cook time • * • * • * • *
<p><i>*Denotes remedy is a difficult operation and should be performed by qualified personnel only. It is recommended, however, that All repairs and/or adjustments be done by your local Blodgett service agency and not by the owner/operator. Blodgett cannot assume responsibility for damage as a result of servicing done by unqualified personnel.</i></p>	



WARNING!!

Always disconnect the power supply before cleaning or servicing the oven.



POSSIBLE CAUSE(S)	SUGGESTED REMEDY
SYMPTOM: Product dried out	
<ul style="list-style-type: none"> • Oven temperature too low • Not using enough water in the mix • Thermostat out of calibration • Faulty flue (strong direct vent) 	<ul style="list-style-type: none"> • Increase cook temperature • Increase water in product mix • * • *
SYMPTOM: Extended baking times	
<ul style="list-style-type: none"> • Temperature setting too low • Low gas pressure • Strong ventilation • Excessive door openings 	<ul style="list-style-type: none"> • Increase cook time • * • * • Do not open door unnecessarily
<p><i>*Denotes remedy is a difficult operation and should be performed by qualified personnel only. It is recommended, however, that All repairs and/or adjustments be done by your local Blodgett service agency and not by the owner/operator. Blodgett cannot assume responsibility for damage as a result of servicing done by unqualified personnel.</i></p>	



WARNING!!

Always disconnect the power supply before cleaning or servicing the oven.