



**BAKERS  
PRIDE®**



OPERATION MANUAL

**HD COOKLINE SERIES COUNTERTOP ELECTRIC FRYERS**

**SERIES: HDEF**



**BUILT BY CRAFTSMEN. TESTED BY TIME®.**



# HEAVY DUTY ELECTRIC FRYER OPERATION MANUAL

## HEAVY DUTY ELECTRIC FRYER OPERATION MANUAL

### Heavy Duty Electric Fryer Models: HDEF-15Si, HDEF-30Ti

Bakers Pride Oven Company, LLC is a wholly owned subsidiary of Standex International Corporation.

Congratulations on your purchase of a Bakers Pride® electric fryer.

(US & Canadian units are convertible and are assembled for Natural Gas)

(European units are not convertible and assembled for the appropriate gas)

### ⚠ WARNING

FOR YOUR SAFETY: Do not store or use gasoline or other flammable vapors or liquids in the vicinity of this or any other appliance.

### ⚠ WARNING

Improper installation, adjustment, alteration, service or maintenance can cause property damage, injury or death. Read the installation, operating and maintenance instructions thoroughly before installing or servicing this equipment.

This equipment has been engineered to provide you with year-round dependable service when used according to the instructions in this manual and standard commercial kitchen practices

### ⚠ WARNING

Initial heating of oven may generate smoke or fumes and must be done in a well-ventilated area. Overexposure to smoke or fumes may cause nausea or dizziness.

Please complete this information and retain this manual for the life of the equipment. For Warranty Service and/or Parts, this information is required.

Model Number

Serial Number

Date Purchased

### ⚠ WARNING

California Residents Only  
WARNING: This product can expose you to chemicals including chromium which is known to the State of California to cause cancer and birth defects or other reproductive harm. For more information go to [www.P65Warnings.ca.gov](http://www.P65Warnings.ca.gov).



### BAKERS PRIDE OVEN COMPANY, LLC.

1307 N. Watters Rd., Suite 180  
Allen, TX 75013

Phone: 800.527.2100 | Fax: 914.576.0605 | [www.bakerspride.com](http://www.bakerspride.com)



---

## TABLE OF CONTENTS

INTRODUCTION	1
SAFETY PRECAUTIONS	2
GENERAL INFORMATION	4
DESCRIPTION	4
INSTALLATION	4
THERMOSTAT CALIBRATION	5
OPERATING	6
MAINTENANCE	6
CLEANING	7
SPECIFICATIONS	8
WIRING DIAGRAMS	9
TROUBLESHOOTING GUIDE	13
SUGGESTED TEMPERATURE & TIMES	14
REPLACEMENT PARTS	15
WARRANTY	21

---

## INTRODUCTION

Bakers Pride takes pride in the design and quality of our products. When used as intended and with proper care and maintenance, you will experience years of reliable operation from this equipment. To ensure best results, it is important that you read and follow the instructions in this manual carefully.

Installation and start-up should be performed by a qualified installer who thoroughly read, understands and follows these instructions.

If you have questions concerning the installation, operation, maintenance or service of this product, write Technical Service Department: Bakers Pride Oven Co., Inc., 1307 N Watters Rd. Suite 180, Allen, TX 75013.

### **Immediately Inspect For Shipping Damage**

All containers should be examined for damage before and during unloading. The freight carrier has assumed responsibility for its safe transit and delivery. If equipment is received damaged, either apparent or concealed, a claim must be made with the delivering carrier.

- A) Apparent damage or loss must be noted on the freight bill at the time of delivery. It must then be signed by the carrier representative (Driver). If this is not done, the carrier may refuse the claim. The carrier can supply the necessary forms.
- B) Concealed damage or loss if not apparent until after equipment is uncrated, a request for inspection must be made to the carrier within 15 days. The carrier should arrange an inspection. Be certain to hold all contents and packaging material.

Installation and start-up should be performed by a qualified installer who thoroughly read, understands and follows these instructions.



## SAFETY PRECAUTIONS

### **⚠ DANGER**

This symbol warns of imminent hazard which will result in serious injury or death.

### **⚠ WARNING**

This symbol refers to a potential hazard or unsafe practice, which could result in serious injury or death.

### **⚠ CAUTION**

These models are designed, built, and sold for commercial use. If these models are positioned so the general public can use the equipment make sure that cautions, warnings, and operating instructions are clearly posted near each unit so that anyone using the equipment will use it correctly and not injure themselves or harm the equipment.

### **⚠ WARNING**

Check the data plate on this unit before installation. Connect the unit only to the voltage and frequency listed on the data plate. Connect only to 1 or 3 phase as listed on the data plate.

### **⚠ WARNING**

Electrical and grounding connections must comply with the applicable portions of the national electrical code and/or other local electrical codes.

### **⚠ WARNING**

Disconnect device from electrical power supply and place a Tag Out-Lockout on the power plug, indicating that you are working on the circuit.

### **⚠ CAUTION**

This symbol refers to a potential hazard or unsafe practice, which may result in or moderate injury or product or property damage.

### **NOTICE**

This symbol refers to information that needs special attention or must be fully understood even though not dangerous.

### **⚠ WARNING**

Install per the spacing requirements listed in the installation section of this manual. We strongly recommend having a competent professional install the equipment. A licensed electrician should make the electrical connections and connect power to the unit. Local codes should always be used when connecting these units to electrical power. In the absence of local codes, use the latest version of the National Electrical Code.

### **⚠ WARNING**

This device should be safely and adequately grounded in accordance with local codes, or in the absence of local codes, with the National Electrical code, ANSI/NFPA 70, Latest Edition to protect the user from electrical shock. It requires a grounded system and a dedicated circuit, protected by a fuse or circuit breaker of proper size and rating. Canadian installation must comply with the Canadian Electrical Code, CSAC22.2, as applicable.

### **⚠ CAUTION**

Do not set the fryer with its back flat against the wall. It will not operate properly unless there is at least 3" breathing space behind fryer.



## SAFETY PRECAUTIONS

### **⚠ WARNING**

A factory authorized agent should handle all maintenance and repair. Before doing any maintenance or repair, contact Bakers Pride.

### **⚠ WARNING**

Never clean any electrical unit by immersing it in water. Turn off before cleaning surface.

### **⚠ WARNING**

An earthing cable must connect the appliance to all other units in the complete installation and from there to an independent earth connection.

### **NOTICE**

The unit when installed must be electrically grounded and comply with local codes, or in the absence of local codes, with the national electrical code ANSI/NFPA70-latest edition. Canadian installation must comply with CSA-STANDARD C.22.2 Number 0 M1982 General Requirements-Canadian Electrical Code Part II, 109-M1981-Commercial Cooking Appliances.

### **⚠ WARNING**

**SHOCK HAZARD** - De-energize all power to equipment before cleaning the equipment.

### **NOTICE**

This product is intended for commercial use only. Not for household use.

### **NOTICE**

Local codes regarding installation vary greatly from one area to another. The National Fire Protection Association, Inc. states in its NFPA96 latest edition that local codes are "Authority Having Jurisdiction" when it comes to requirement for installation of equipment. Therefore, installation should comply with all local codes.

### **⚠ CAUTION**

This product when stacked has more than one power supply connection point. Disconnect all power supplies before servicing.

### **⚠ CAUTION**

Suitable for installation on combustible floor when installed with legs or casters provided.

### **⚠ WARNING**

**SHOCK HAZARD** - Do not open any panels that require the use of tools.



## HEAVY DUTY ELECTRIC FRYER OPERATION MANUAL

---

### GENERAL INFORMATION

#### General Installation:

1. Always clean equipment thoroughly before first use (see "General Cleaning Instructions").
2. Check rating label for your model designation & electrical rating.
3. For best results, use stainless steel countertops.
4. Attach legs to unit.

#### General Operation Instructions:

1. All food service equipment should be operated by trained personnel.
2. Do not allow your customers to come in contact with any surface labeled "CAUTION HOT".
3. Where applicable, never pour cold water into dry heated units.
4. NEVER hold food below 140°F.

#### General Cleaning Instructions:

1. Refer to section 8, page 7.

#### General Troubleshooting:

Always ask and check:

1. Is the unit connected to a live power source?
2. Check circuit breaker.
3. Is power switch "ON" and pilot light glowing?
4. Check rating label. Are you operating unit on proper voltage?

If the above checks out and you still have problems, call a Bakers Pride authorized service agency.

---

### DESCRIPTION

#### Electric Fryers:

These electric units are designed for countertop operation. They are used for producing evenly cooked, perfectly fried products.

---

### INSTALLATION

1. Follow General Installation Instructions on previous page.

Screw legs into the permanently fastened nuts on the four corners of the unit and tighten by hand. Level the fryer by turning the adjustment screw at the bottom of each leg. Do not slide unit with legs mounted, lift if necessary to move unit.

For testing, see the wiring diagrams in this manual for the rated amperages.

#### **⚠ CAUTION**

Installing personnel should be guided by National Electrical Code NFPA Number 70- (Latest Edition), and applicable local codes.

## THERMOSTAT CALIBRATION

### Checking Thermostat Calibration:

The fryer thermostat is carefully calibrated at the factory so that dial settings match actual frying compound temperatures. Field re-calibration is seldom necessary unless the unit has been mishandled in transit or abused. Re-calibration should not be resorted to unless considerable experience with cooking results definitely proves that the control is not maintaining the temperature to which the dial is set.

1. To check compound frying temperatures when re-calibrating, use a precision test instrument, or a good grade mercury thermometer. Fill the tank half way between the MAX and MIN marks on the tank.
2. Frying compound temperature should be checked at the center of the tank, approximately 1" to 1 1/2" below surface of frying compound.
3. Turn the dial of the thermostat being checked to the 350°F mark.
4. Allow temperature to stabilize, or until the thermostat cycles to "OFF" three times after starting with cold frying compound. With power "ON", read highest and lowest frying compound temperature, as thermostat cycles through at least two cycles. Average the reading.
5. Thermostat should be re-calibrated if temperature reading is not within 10 degrees of the control knob setting (350°F +/- 15°F). If re-calibration is required, continue with steps 6, 7, 8 and 9.
6. Remove control knob by grasping outer edge and pulling straight out, without twisting or turning.

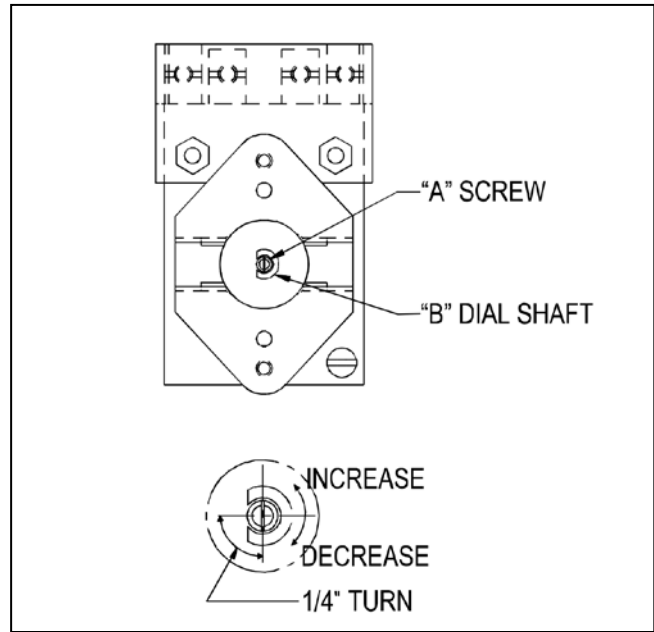

Figure 1

7. Hold thermostat dial shaft "B" (Figure 1) stationary with pliers, and with a screwdriver, turn screw "A" clockwise to obtain a lower temperature; or counter-clockwise for higher temperature. Each 1/4 turn (90° rotation) of screw "A" represents 18°F.
8. Replace thermostat control knob.
9. Recheck thermostat as in Steps 4 and 5 above. If the fat temperature is not within 20 degrees of dial setting (350°F +/- 20°F), it means that the sensing element is inoperative and the thermostatic control should be replaced.



## HEAVY DUTY ELECTRIC FRYER OPERATION MANUAL

---

### OPERATING

#### Removing Fry Tanks (Fry tanks equipped with drain are not to be removed):

1. Remove fry baskets.
2. Carefully grasp the element handle. CAUTION: May be hot. Pull out the head lock on the left of the head.
3. Lift the element handle while at the same time, pulling the head lock. This will permit lifting the elements to just above frying compound level in tank. The element can be left in this position for draining frying compound.
4. Again, lift the element handle while pulling the head lock, until the elements lock themselves at a higher position.
5. Firmly grasp both handles of fry tank and lift it out. After replacing the fry tank, simply pull the head lock; and at the same time, pull down the element handle until the elements rest on fry tank bottom.
6. Both the lifting out and lowering of elements can be done in one swing, without stopping at the intermediate position.

---

### MAINTENANCE

#### Fill Fry Tank:

1. Fill the fry tank half way between the MAX and MIN marks on the tank with approximately 15 lbs. of liquid or melted frying compound. Do not fill past the MAX.

#### NOTICE

This fryer is not equipped with a melt cycle option. Air holes caused when packing solid frying compound into the fryer can cause hot spots on the heating element sheath, resulting in momentary overheating of some of the frying compound and premature frying compound breakdown. It can also damage the heating elements. If it is necessary to use solid frying compound, it must be melted before adding to fry tank.

Turn the thermostat to the desired frying temperature. The yellow "HEAT ON" light will stay on until the temperature set on the thermostat is reached, then the light cycles off. The fryer is now ready to begin frying. After a load has been fried, do not lower the next load into the frying compound until the "HEATON" light cycles off.

2. Do not let the frying compound level drop below the MIN mark on the tank. For proper operation of the fryer and good frying results, the frying compound level should be maintained.

3. Use a quality frying compound.
4. Filter the frying compound frequently, at least once a day.
5. Skim out food particles frequently with the strainer/skimmer.
6. Add at least 15% (of fry tank capacity) of fresh frying compound daily, (more if possible) without overloading the tank. If 15% of the frying compound is not used during frying, remove some of the frying compound for other use (gravy, griddle frying, etc.) to permit adding fresh frying compound.
7. Do not overload the fry baskets. Approximately half-full or even less is correct. If foods are taking longer to fry than the chart shows, or are not browning, over-loading is a probable cause.
8. Prepare the food properly.
9. Keep salt out of the frying compound. Do not salt foods with the basket above the kettle.
10. Assure a good thermostat operation.
11. Keep the fry tank and elements clean.



## HEAVY DUTY ELECTRIC FRYER OPERATION MANUAL

### CLEANING

1. The frequency of cleaning should depend on the load conditions. Set a definite cleaning schedule corresponding to how hard the kettle is used. Cleaning should be done at least once a week.
  - A. Turn the thermostat to "OFF" and allow unit to cool down.
  - B. Lift the elements to drain position. Wire brush or scrape elements to remove any solids adhering to the elements.
  - C. Raise the elements. Lift out fry tank. Strain the frying compound into a clean container.
  - D. Replace empty fry tank, lower elements to rest inside the tank.
  - E. Add water to the "MAX" mark on tank.
  - F. Add any good grade of cleaner, following cleaning instructions.
  - G. Turn the thermostat to 250°F and let the heating unit bring the solution to a boil.
  - H. Boil long enough to loosen or dissolve all varnish or carbon deposits, approximately 30 minutes.
  - I. Turn the unit off and lift out the elements to drain position.
  - J. If necessary, clean the thermostat bulbs using a long-handled fiber or plastic brush and mild soap solution.
  - K. Rinse with clean water to remove all cleaning mixture.
  - L. Lift out the fry tank and drain. Repeat steps J & K with fry tank.
  - M. Rinse the inside of the tank with 2 cups of vinegar.
  - N. Rinse with clean water until the vinegar odor is gone. The fry tank must be thoroughly rinsed, since even a trace of cleaner left inside the tank will ruin frying compound.
  - O. Dry thoroughly. Replace the tank and lower the elements.
  - P. Shut the unit off and cover tank until ready for further use.
  - Q. Thin films of oil subjected to frying temperatures quickly form into a gummy consistency. In order to avoid these gum formations, keep all other surfaces of the unit clean by polishing stainless steel surfaces with a damp cloth. To remove discolorations or oil film, a nonabrasive cleaner may be used.

#### **⚠ CAUTION**

The Use only non-abrasive cleaners. Abrasive cleaners could scratch the finish of your unit, marring it's appearance and making it susceptible to dirt accumulation. Do Not use steel wool, other abrasive cleaners or cleaners/sanitizers containing chlorine, iodine, ammonia or bromine chemicals as these will deteriorate the stainless steel and glass material and shorten the life of the unit.

#### **⚠ CAUTION**

The Use only non-abrasive cleaners. Abrasive cleaners could scratch the finish of your unit, marring it's appearance and making it susceptible to dirt accumulation. Do Not use steel wool, other abrasive cleaners or cleaners/sanitizers containing chlorine, iodine, ammonia or bromine chemicals as these will deteriorate the stainless steel and glass material and shorten the life of the unit.

**SPECIFICATIONS**

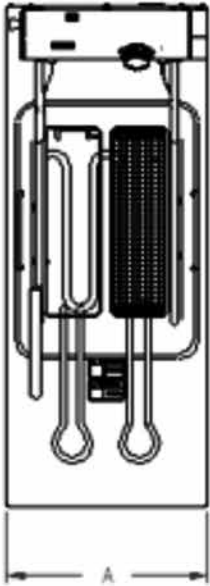

Dimensions & Electrical Information							
Model	A	B	C	D	Watts	Volts	Amps
HDEF-15i	12	17.553	30.000	13.5	5700	208	23.8
	12	17.553	30.000	13.5	5700	230	21.4
	12	17.553	30.000	13.5	5700	240	20.6
HDEF-30i	24	17.553	30.000	13.5	11400	208	47.6
	24	17.553	30.000	13.5	11400	230	42.9
	24	17.553	30.000	13.5	11400	240	41.2

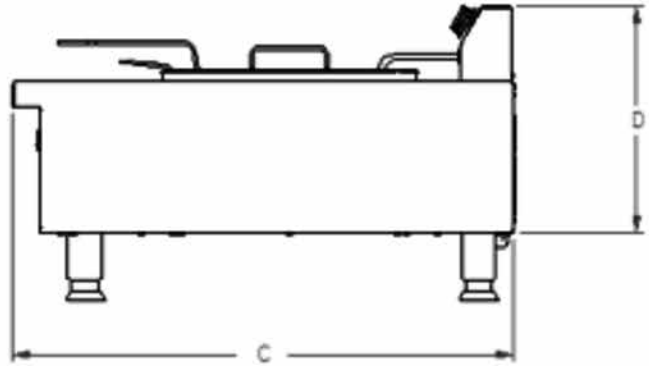
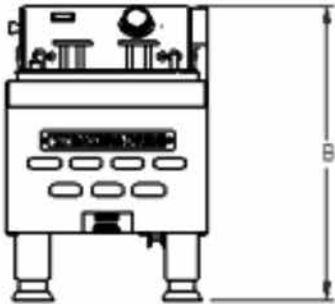

**WIRING DIAGRAM**

CHECK DATA PLATE & CONNECT TO 208 OR 240V AS INDICATED.

MODEL #	VOLTS	WATTS	AMPS	WIRE	VOLTS	WATTS	AMPS	WIRE
EF15-Ni	240	5700	23.8	12	208	4280	20.6	12
EF15-Ni-208	-	-	-	-	208	5700	27.5	10

Wire sizes listed above are for reference only. Check local codes or the National Electrical Code for sizes to be used.

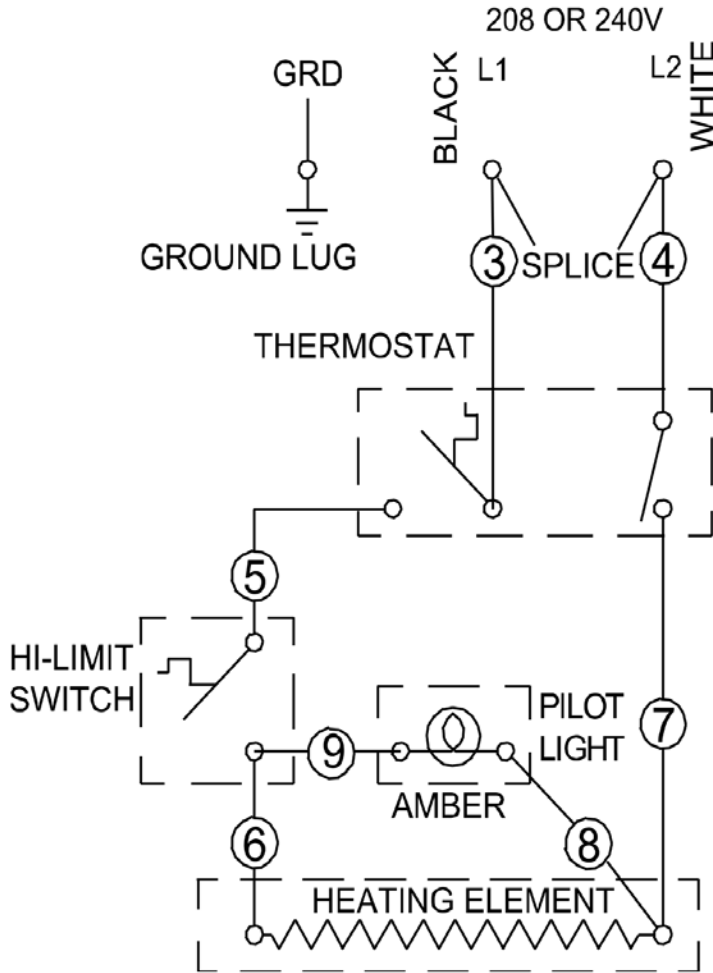

**⚠ WARNING**  
THIS UNIT TO BE CONNECTED TO 1Ø ONLY

**WIRING DIAGRAM**

CHECK DATA PLATE & CONNECT TO 208 OR 240V AS INDICATED.

MODEL #	VOLTS	WATTS	AMPS	WIRE	VOLTS	WATTS	AMPS	WIRE
EF30-NTi	240	11400	47.6	6	208	8560	41.2	6

Wire sizes listed above are for reference only. Check local codes or the National Electrical Code for sizes to be used.

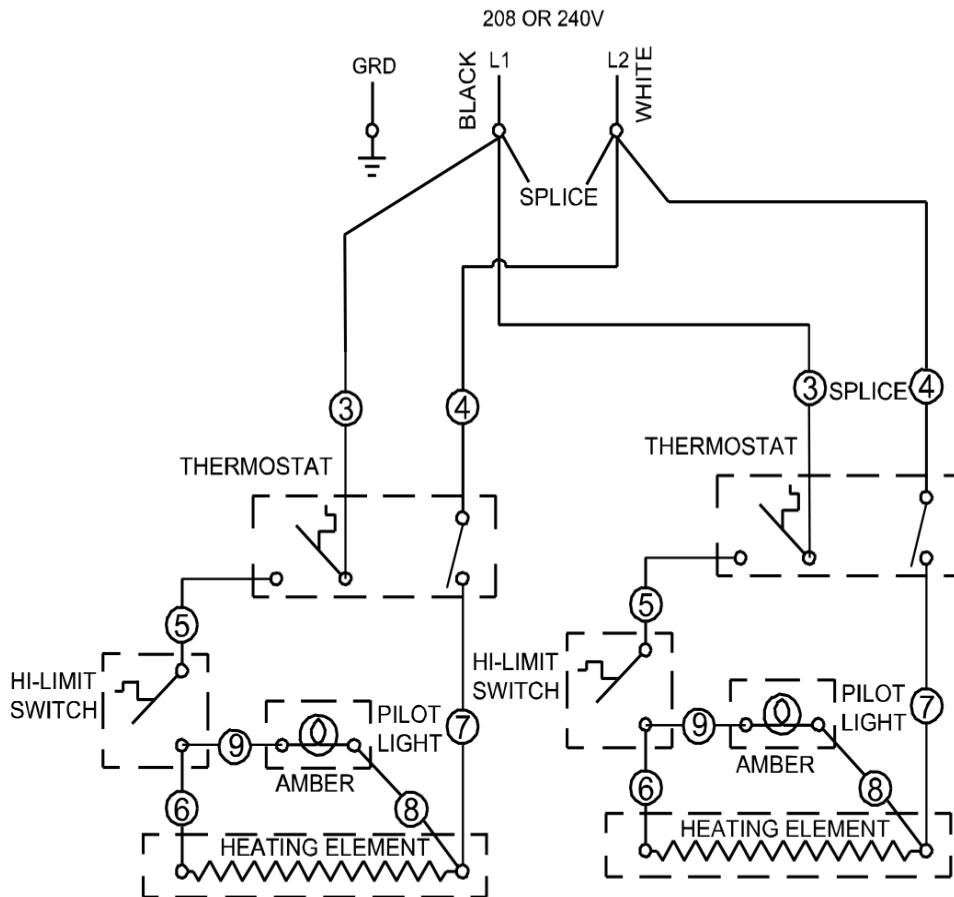

**⚠ WARNING**  
THIS UNIT TO BE CONNECTED TO 1Ø ONLY

**WIRING DIAGRAM**

CHECK DATA PLATE & CONNECT TO 208 OR 240V AS INDICATED.

MODEL #	VOLTS	WATTS	AMPS	WIRE	VOLTS	WATTS	AMPS	WIRE
EF30-NTi	240	11400	23.8 & 23.8	12	208	8560	20.6 & 20.6	12

Wire sizes listed above are for reference only. Check local codes or the National Electrical Code for sizes to be used.

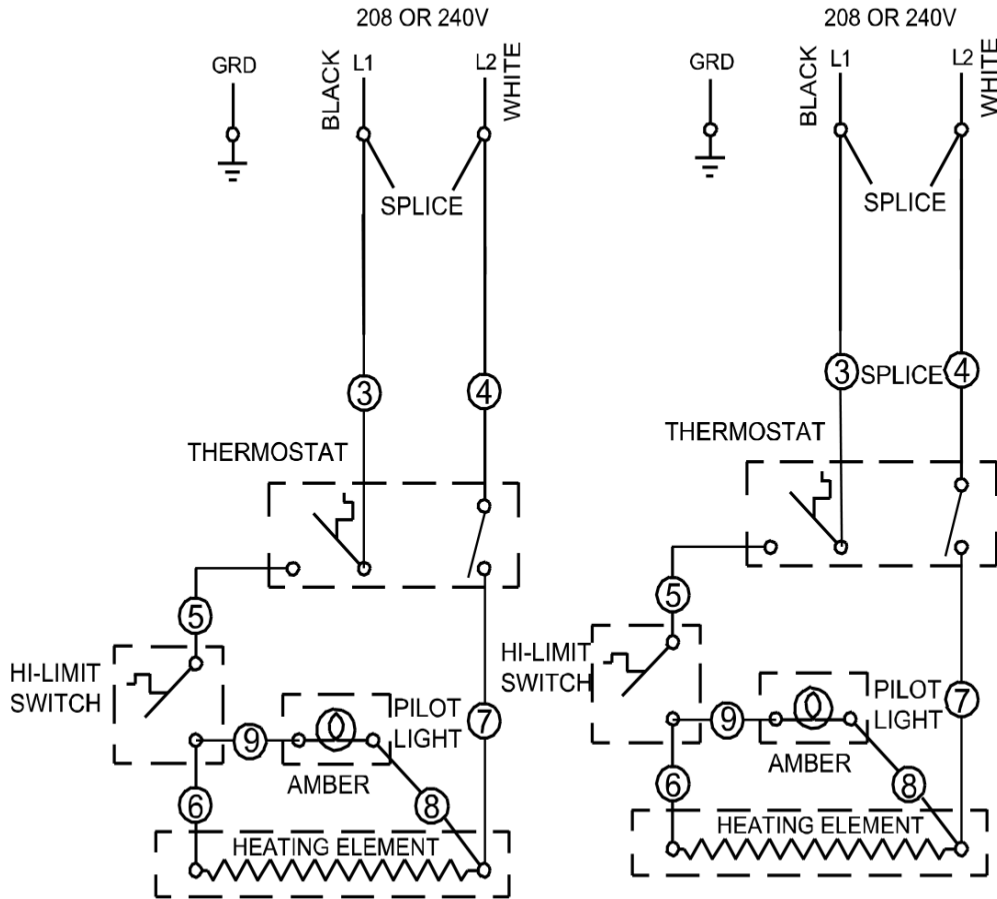

**⚠ WARNING**  
 THIS APPLIANCE HAS MORE THAN ONE POWER SUPPLY CONNECTION POINT. DISCONNECT ALL POWER SUPPLIES BEFORE SERVICING

**⚠ WARNING**  
 THIS UNIT TO BE CONNECTED TO 1Ø ONLY

**WIRING DIAGRAM**

CHECK DATA PLATE & CONNECT TO 208 OR 240V AS INDICATED.

MODEL #	VOLTS	WATTS	AMPS	WIRE
EF30-NTCi-208	208	11400	55.0	4

Wire sizes listed above are for reference only. Check local codes or the National Electrical Code for sizes to be used.

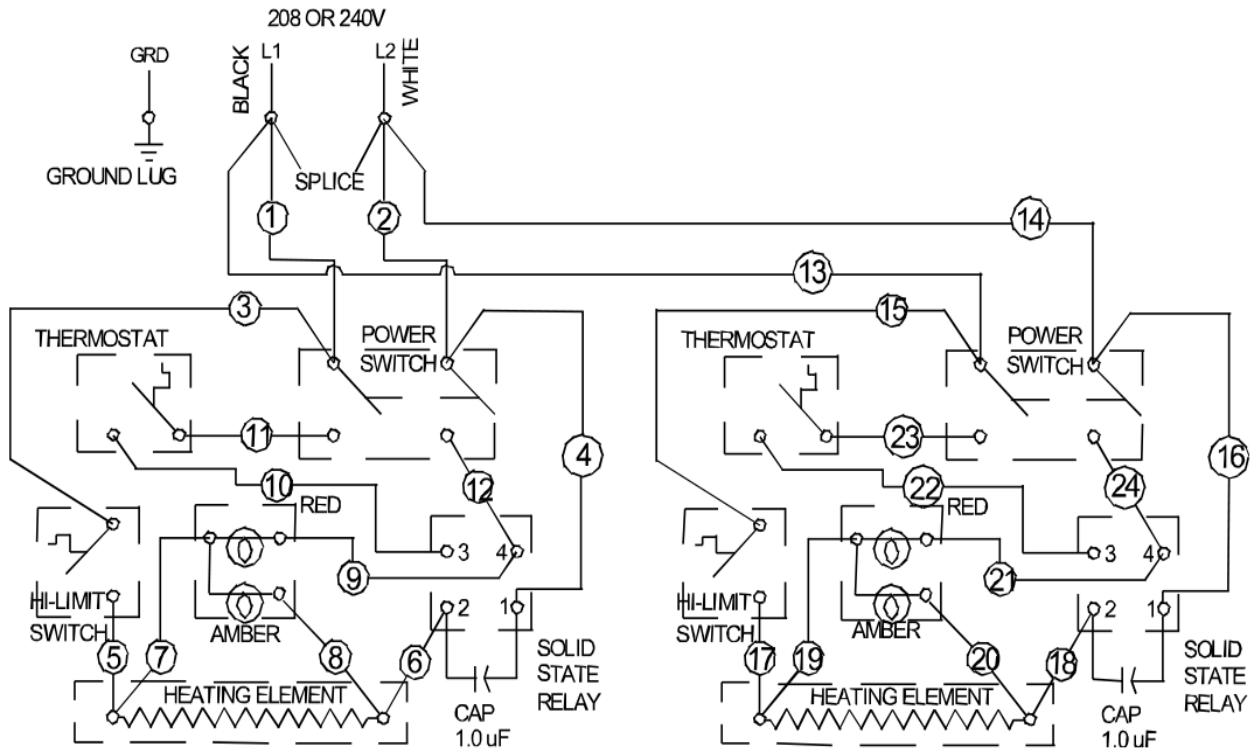

**⚠ WARNING**

THIS UNIT TO BE CONNECTED TO 1Ø ONLY



**TROUBLESHOOTING**

Problem	Possible Cause																
	Frying temperature too high/ overheating. (Check thermostat)	Frying temperature too low. (Check thermostat)	Overloading the fry tank.	Improper draining of food after frying.	High moisture content in food being fried.	Inadequate frying compound turnover.	Improper preparation of food.	Contamination of frying compound. (Due to salt or other foreign material)	Frying in foam.	Food being fried may be of poor quality.	Food being fried may be of poor quality.	Poor quality of frying compound (Either initially or after excessive use)	Cooking time too short.	Inadequate filtering of frying compound. Excessive crumbs in fry tank.	Keeping food in frying compound after cooking.	Inadequate cleaning of fry tank.	
Excessive and premature foaming.	X		X			X		X					X		X		X
Greasy food/excessive frying compound absorption.		X	X	X	X	X	X		X				X			X	
“Objectionable” odor or flavor of frying compound.					X	X		X		X	X	X		X	X	X	
“Objectionable” flavor of fried food.				X		X	X			X	X	X	X	X	X		
Excessive smoking of frying compound.	X					X	X	X					X		X		X
Excessive darkening of frying compound.	X					X	X	X						X			X
Frying compound won't hold heat.		X	X		X		X										
Food crust color not brown.		X	X		X		X		X				X				
Rapid breakdown of frying compound.	X				X		X	X	X		X	X		X			X



## HEAVY DUTY ELECTRIC FRYER OPERATION MANUAL

### SUGGESTED TEMPERATURES & TIMES

Food	Control Setting (°F)	Time in Minutes	Food	Control Setting (°F)	Time in Minutes
<b>DOUGHNUTS</b>			<b>SEAFOOD</b>		
Cake Type	375°	1 ½ - 2	Fish Cakes	350°	2 - 3
Yeast Raised	375°	2 - 2 ½	Clams	350°	1 - 3
<b>MEAT</b>			Filletts (Small)	350°	3 - 5
Cutlets (Less than 1/2" thick)	350°	5 - 8	Oysters	350°	2 - 5
Chicken Fried Steak	350°	5 - 8	Scallops	350°	3 - 5
Chops (Very lean)	350°	5 - 8	Shrimp	350°	4 - 6
<b>MISCELLANEOUS</b>			Smelts	350°	4 - 6
Chinese Noodles	375°	1 - 2	<b>VEGETABLES</b>		
Croquettes	350°	2 - 3	Egg Plant	350°	5 - 7
French Toast	350°	2 - 3	Onion Rings	350°	3 - 5
Glazed Cinnamon Apples	300°	5 - 10	Potatoes		
French Fried Sandwiches	350°	1 - 2	(1/2" Strips, one-operation)	350°	6 - 9
<b>POULTRY</b>			Potatoes (Blanch)	350°	4 - 6
Chicken (Large pieces)	325°	10 - 5	Potatoes (Brown)	350°	2 - 3
Chicken (Small pieces)	350°	7 - 10	Potatoes (Julienne)	350°	3 - 5
Chicken (Pre-cooked)	325° - 350°	3 - 5			
Turkey (Small pieces)	325°	9 - 10			

**REPLACEMENT PARTS**

**Control Head (Models: EF-15Ni & EF-30NTi)**

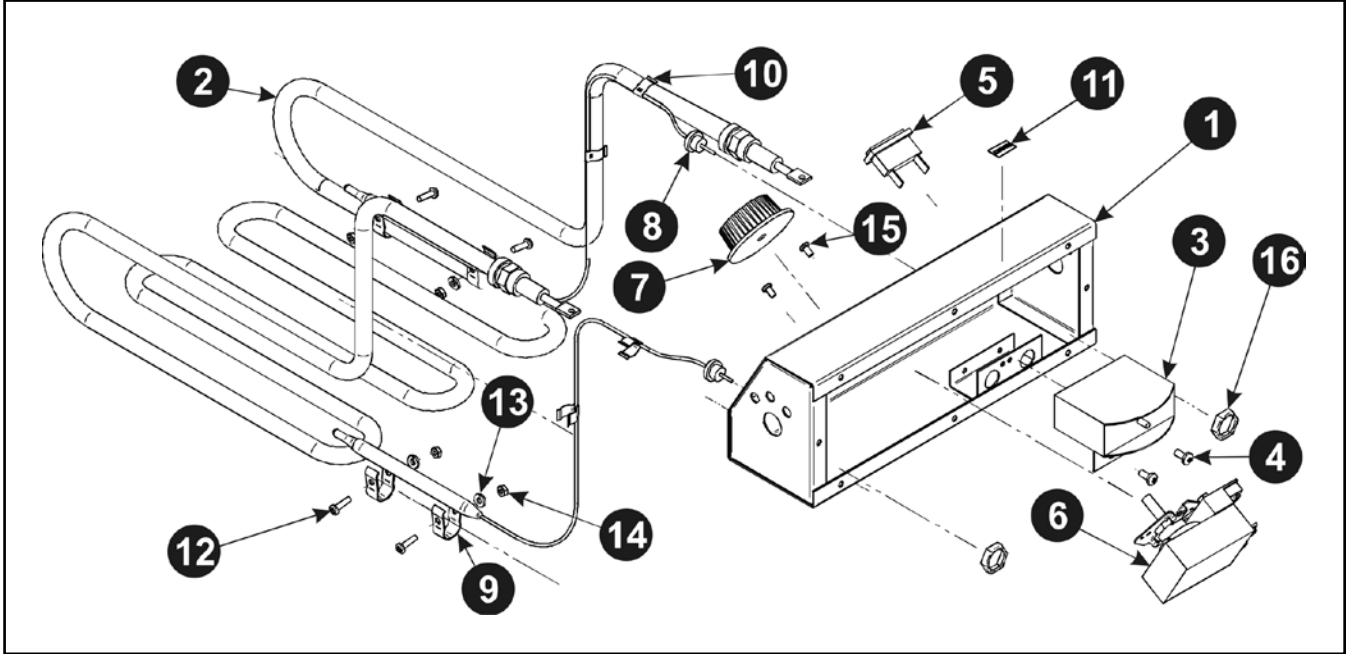

Item	P/N	Description	Quan	Item	P/N	Description	Quan
1	218100-95	Control Head, Elec. Fryer W/a	1	9	64285901	Clamp Bulb	4
2	1439729	Heating Unit Assembly	1	10	8944100	Clip Lead	4
3	13801-00	Switch, Hi-limit	1	11	8837018	Label Reset	1
4	81300-00	8-32 X 3/8 Type T	2	12	8108300	Screw, Pan Head 6-32 X 1/2	4
5	1515300	Ind Light,rect,amb,250v,2/tabs	1	13	8500600	Washer, Lock #6 S/s	4
6	14876-00	Thermostat	1	14	8402900	Nut, Hex, 6-32 Ss	4
7	8705504	Knob, Thermostat	1	15	8103400	Screw, Mach, 6-32 X 1/4" Lg.	2
8	2125502	Grommet Split	2	16	8455700	Nut, PAL 5/8-18	2



## HEAVY DUTY ELECTRIC FRYER OPERATION MANUAL

### REPLACEMENT PARTS

HDEF-15Si

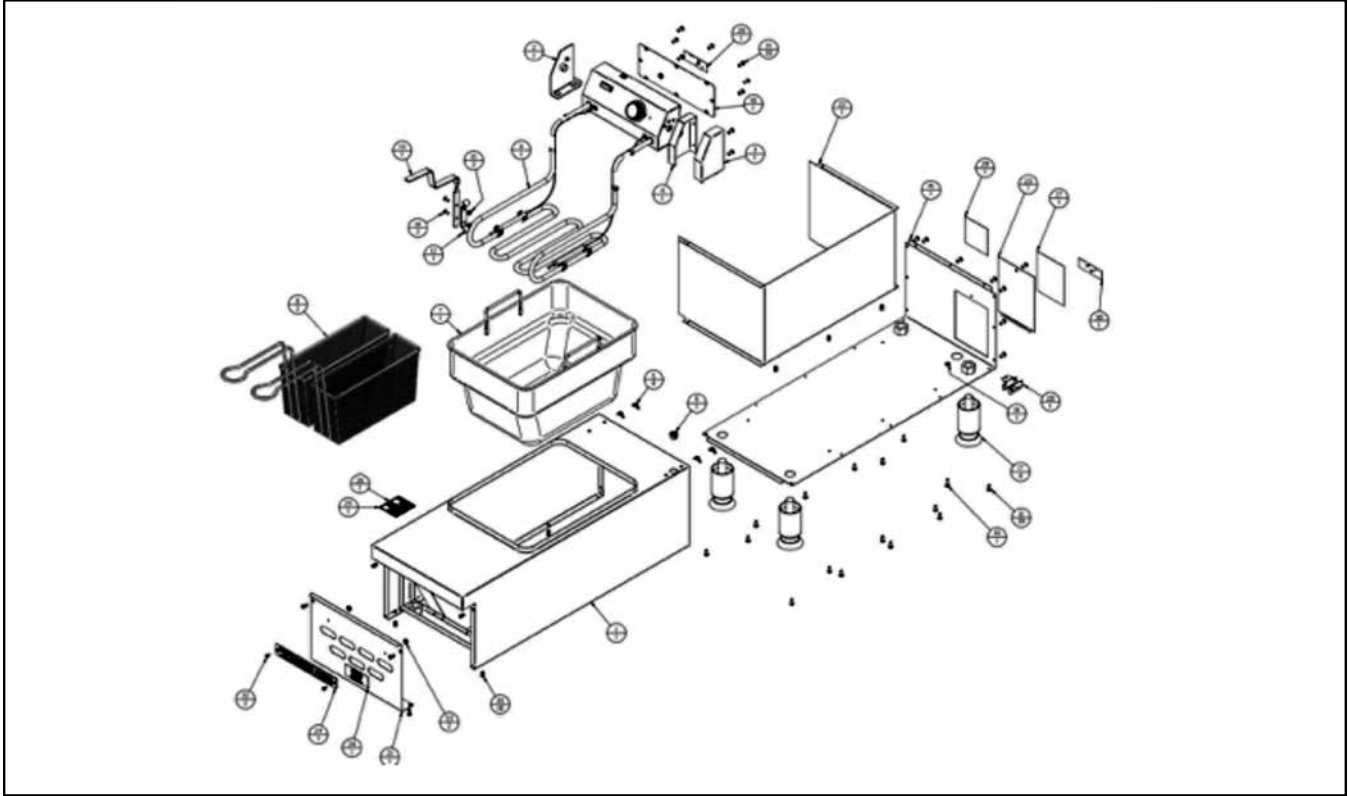

Item	P/N	Description	Qty	Item	P/N	Description	Qty
1	22491151	BODY, FRYER BP	1	18	8422400	#10-24 HX NUT GRN	1
2	21810065	SUPPORT, HEAD WELD ASSEMBLY LS	1	19	8158800	MS RD HD PH 10-24 X 1/2	1
3	21810075	HEAD SUPPORT OUTSIDE WELD ASSY	1	20	5161000	CONNECTOR CABLE ROMEX	1
4	21810085	HEAD SUPPORT INSIDE	1	21	21828318	PANEL, FRONT	1
5	8415500	WING NUT 10-32 S/S	4	22	21828038	FABBLE, INTERIOR	1
6	89670-00	BUSHING, SNAP HEYCO .5" I.D.	1	23	21810040	DOOR ELECTRIC FRYER	1
7	21810010	FAT CONTAINER AY	1	24	8808900	NAMEPLATE, BAKERS PRIDE 8"	1
8	3101230	BASKET, 1/2 SIZE	2	25	43813103	LABEL, WRNG, HOT SURFC	1
9	21828240	CONTROL AY, 208/240°F	1	26	43813149	LABEL, WRN HOT SURF (FRNCH)	1
10	21810096	COVER HEAD	1	27	21810018	LABEL, DIAGRAM	1
11	8170700	SCREW, 10-32X1/2, TYPE AB	37	28	8861000	LABEL, SPEC	1
12	2180023	BRACKET HANDLE	1	29	8824200	LABEL, BUTTON POSITION	1
13	2180022	ELEMENT HANDLE	1	30	64416801	LABEL, 90 DEG C	1
14	8141400	8-32 X 1/2 MS	2	31	2901051	CARTON RSC 39.25X19.87X20.18	1
15	84101-00	NUT, HEX 8/32 S/S	2	32	81357-00	SCREW, 8-32 X 3/8" FT HD	2
16	22495100	BACK BOTTOM W/A	1	33	8408300	#8-32 HEX NUT, KEPS, NI	2
17	8633700	LEG, HEAVY DUTY 2" DIA, W/ FOOT FLANGE	4	34	8825300	DECAL, LEG	1
				35	8353500	RIVNUT, #8-32	10

**REPLACEMENT PARTS**

**HDEF-30Ti**

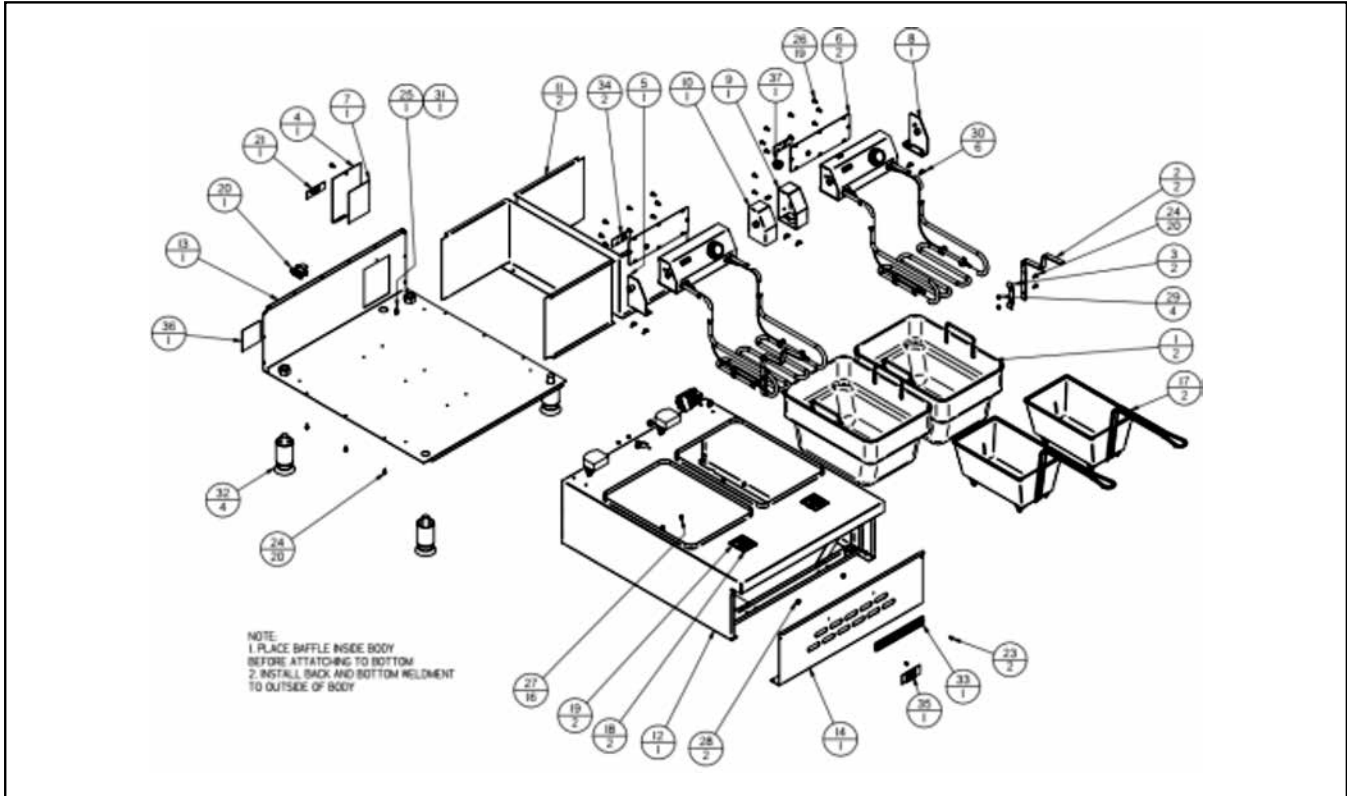

Item	P/N	Description	Qty	Item	P/N	Description	Qty
1	21810010	FAT CONTAINER AY	2	20	5161000	CONNECTOR CABLE ROMEX	1
2	21810022	ELEMENT HANDLE	2	21	64416801	LABEL, 90 DEG C	1
3	21810023	BRACKET HANDLE	2	22	8130000	8-32 X 3/8 TYPE T	18
4	21810040	DOOR ELECTRIC FRYER	1	23	81357-00	SCREW, 8-32 X 3/8" FT HD	2
5	21810065	SUPPOR, HEAD WELD ASSEMBLY LS	1	24	2141400	8-32 X 1/2 MS	20
6	21810096	COVER HEAD	2	25	8158800	MS RD HD PH 10-24 X 1/2	1
7	21810218	LABEL, DIAGRAM EL. TWIN FRYER 208/240V UNITS	1	26	8170700	SCREW, 8-32 X 3/8 TYPE AB	19
8	21810265	SUPPORT, HEAD WELD ASSEMBLY RS	1	27	8353500	RIVNUT, 8-32 THIN HEAD	16
9	21810275	HEAD SUPPORT, OUTSIDE ASSY.	1	28	8408300	#8-32 HEX NUT, KEPS,NI	2
10	21810285	HEAD SUPPORT, INSIDE ASSY.	1	29	84104-00	NUT HEXKEPS, NI	4
11	21828038	BAFFLE, INTERIOR	2	30	8415500	WING NUT 10-32 S/S	6
12	21828526	WELDMENT, BODY HDEF-30BL	1	31	8422400	#10-24 HX NUT GRN	1
13	22295136	BOTTOM/BACK WELDMENR, HDEF30	1	32*	8633700	LEG, HEAVY DUTY 2" DIA. W/ FOOT FLANGE	4
14	22495113	PANEL, FRONT	1	33*	8808900	NAMEPLATE, BAKERS PRIDE 8"	1
15	29087-42	SKID, 44 x 32 FOR 42" MERCHANDISER	1	34	8824200	LABEL, BUTTON POSITION	2
16	29088-42	CARTON, HSC 43.25 X 30.25 X 33.25 275 DW	1	35	8825300	DECAL, LEG	1
17	31012-32	BASKET, FULL SIZE, 30H	2	36	8861000	LABEL, SPEC	1
18	43813103	LABEL, WRNG, HOT SURFC	2	37	89785-00	BUSHING, 1" SANP, HEYCO	1
19	43813149	LABEL, WRN HOT SURF (FRNCH)	2				

**REPLACEMENT PARTS**

**HDEF-15Si (CE)**

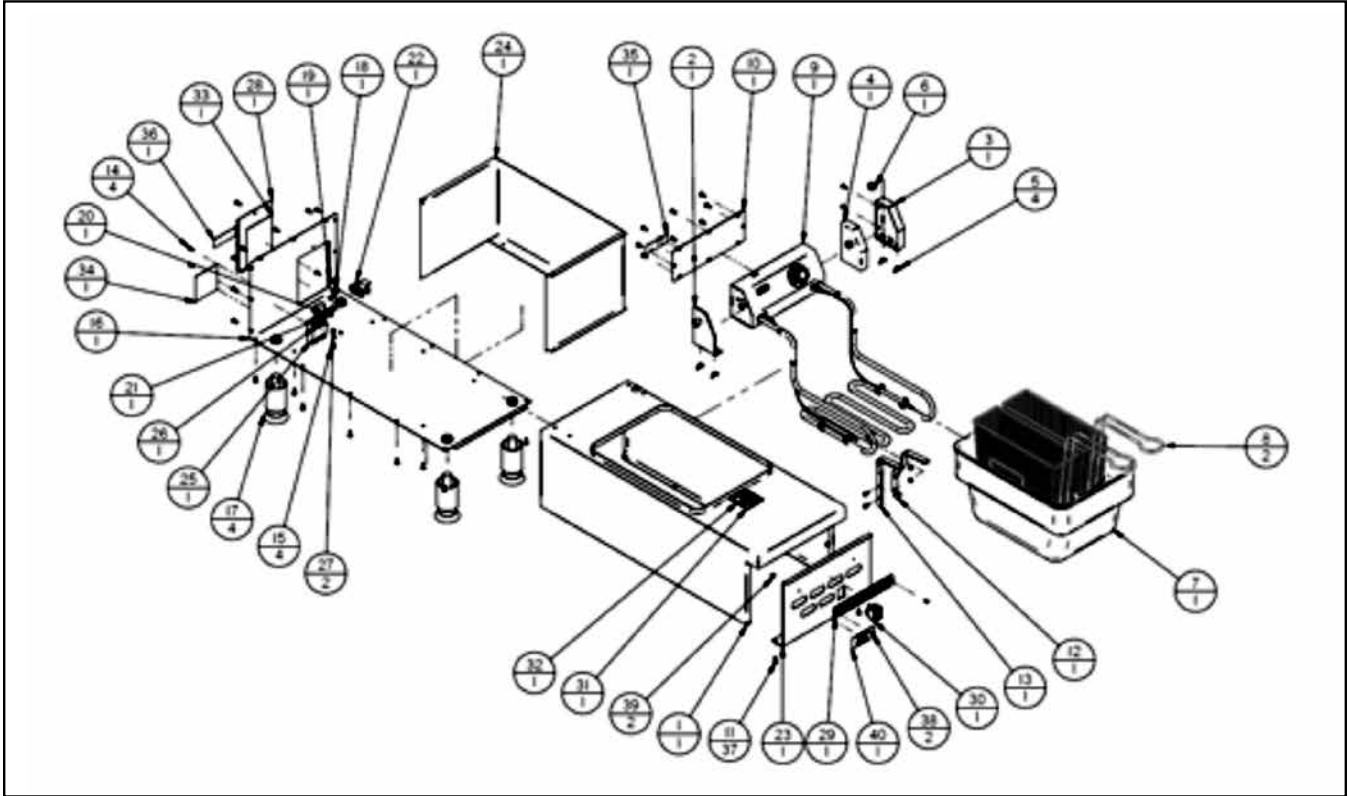

Item	P/N	Description	Qty	Item	P/N	Description	Qty
1	21828325	BODY, FRYER BP	1	21	8158800	MS RD HD PH 10-24 X 1/2	1
2	21810065	SUPPORT, HEAD WELD ASSEMBLY LS	1	22	5161000	CONNECTOR CABLE ROMEX	1
3	21810075	HEAD SUPPORT OUTSIDE WELD ASSY	1	23	21828319	PANEL, FRONT	1
4	21810085	HEAD SUPPORT INSIDE	1	24	21828038	BAFFLE, INTERIOR	1
5	8415500	WING NUT 10-32 S/S	4	25	1302100	RELAY, SOLID STATE	1
6	89670-00	BUSHING, SNAP HEYCO .5" I.D.	1	26	21810042	CAPACITOR, ASSY	1
7	21810010	FAT CONTAINER AY	1	27	8103400	SCREW, MACH, 6-32 X 1/4" LG.	2
8	3101230	BASKET, 1/2 SIZE	2	28	21810040	DOOR ELECTRIC FRYER	1
9	21810150	CONTROL AY. 208/240 °C	1	29	8808900	NAMEPLATE, BAKERS PRIDE 8"	1
10	21810096	COVER HEAD	1	30	1305612	SWITCH, ROCKER 20 AMP	1
11	8170700	SCREW, 10-32x1/2, TYPE AB	37	31	43813103	LABEL, WRNG, HOT SURFC	1
12	21810023	BRACKET HANDLE	1	32	43813149	LABEL, WRN HOT SURF (FRNCH)	1
13	21810022	ELEMENT HANDLE	1	33	21810017	LABEL, DIAGRAM EL. 15LB CE UNITS	1
14	8141400	8-32 x 1/2 MS	4	34	8861000	LABEL, SPEC	1
15	84104-00	NUT,HEX, 8-32 S/S	4	35	8824200	LABEL, BUTTON POSITION	1
16	22495100	BACK, BOTTOM W/A	1	36	64416801	LABEL, 90 DEG C	1
17	8633700	LEG, HEAVY DUTY 2" DIA. W/ FOOT FLANGE	4	37*	2901051	CARTON, RSC 39.25X19.87X20.18	1
18	11141-00	LUG, SOLDERLESS	1	38	81357-00	SCREW, 8-32 X 3/8" FT HD	2
19	8422400	#10-24 HX NUT GRN	1	39	8408300	#8-32 HEX NUT, KEPS, NI	2
20	88370-01	LABEL, GROUND MARKER	1	40	8825300	DECAL, LEG	1

**REPLACEMENT PARTS**

**HDEF-30T (CE)**

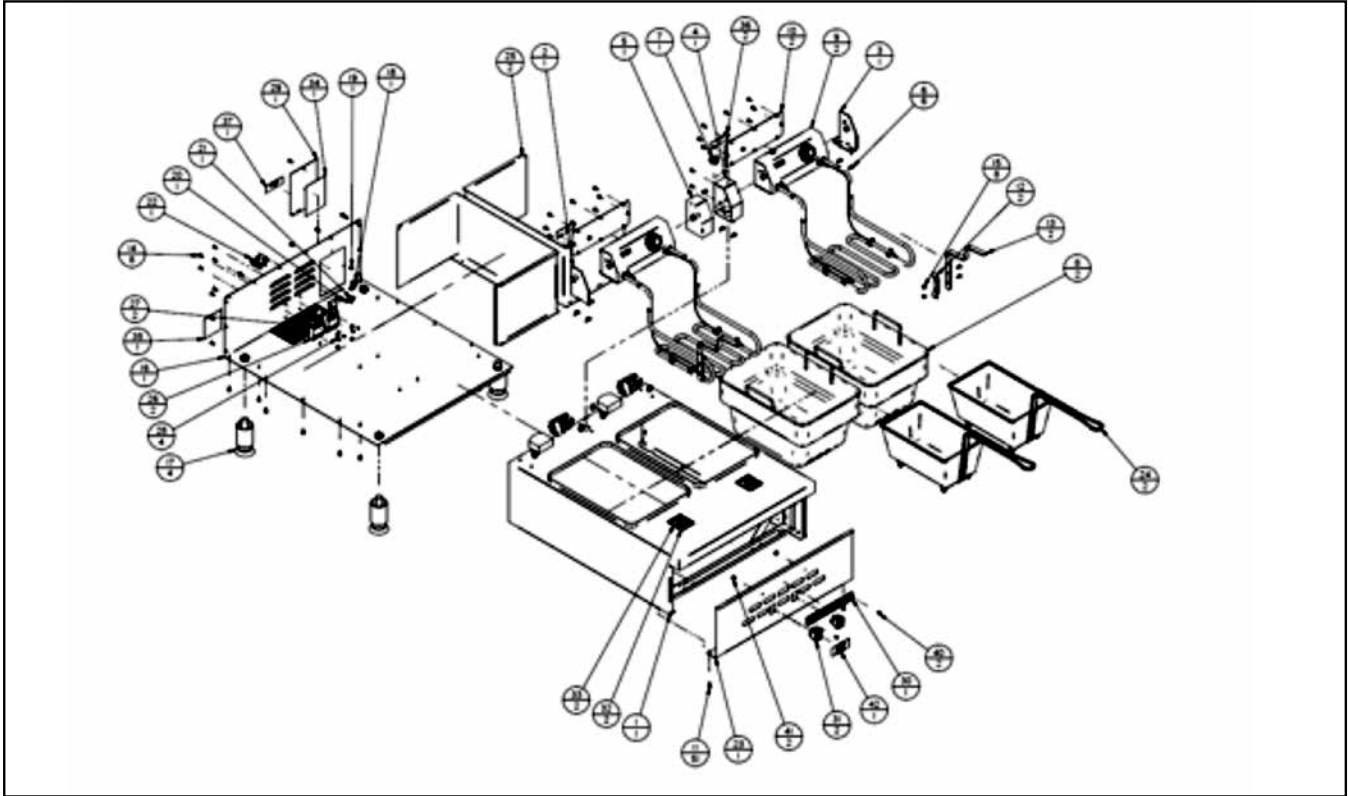

Item	P/N	Description	Qty	Item	P/N	Description	Qty
1	21828526	WELDMENT, BODY HDEF-30BL	1	22	5161000	CONNECTOR CABLE ROMEX	1
2	21810065	SUPPORT, HEAD WELD ASSEMBLY LS	1	23	21828519	PANEL, FRONT	1
3	21810265	SUPPORT, HEAD WELD ASSEMBLY RS	1	24	31012-32	BASKET, FULL SIZE, 30H	2
4	21810275	HEAD SUPPOR, OUTSIDE ASSY.	1	25	21828038	BAFFLE, INTERIOR	2
5	21810285	HEAD SUPPORT, INSIDE ASSY.	1	26	1302100	RELAY, SOLID STATE	2
6	8415500	WING NUT 10-32 S/S	6	27	21810042	CAPACITOR, ASSY	2
7	89785-00	BUSHING, 1" SNAP, HEYCO	1	28	8103400	SCREW, MACH, 6-32 X 1/4" LG.	4
8	21810010	FAT CONTAINER AY	2	29	21810040	DOOR ELECTRIC FRYER	1
9	21810150	CONTROL AY. 208/240 °C	2	30	8808900	NAMEPLATE, BAKERS PRIDE 8"	1
10	21810096	COVER HEAD	2	31	1305612	SWITCH, ROCKER 20 AMP	2
11	8170700	SCREW, 10-32x1/2, TYPE AB	51	32	43813103	LABEL, WRNG, HOT SURFC	2
12	21810023	BRACKET HANDLE	2	33	43813149	LABEL, WRN HOT SURF (FRNCH)	2
13	21810022	ELEMENT HANDLE	2	34	21810216	LABEL, DIAGRAM EL. TWIN FRYER CE UNITS	1
14	8141400	8-32 x 1/2 MS	8	35	8861000	LABEL, SPEC	1
15	84104-00	NUT,HEX, 8-32 S/S	8	36	8824200	LABEL, BUTTON POSITION	2
16	21828135	BACK AND BOTTOM WELDMENT W/O DRAIN	1	37	64416801	LABEL, 90 DEG C	1
17	8633700	LEG, HEAVY DUTY 2" DIA. W/ FOOT FLANGE	4	38*	29087-42	SKID, 44 X 32 FOR 42" MERCHANDISER	1
18	11141-00	LUG, SOLDERLESS	1	39*	29088-42	CARTON, HSC 43.25 X 30.25 X 33.25 275 DW	1
19	8422400	#10-24 HX NUT GRN	1	40	81357-00	SCREW, 8-32 X 3/8" FT HD	2
20	88370-01	LABEL, GROUND MARKER	1	41	8408300	#8-32 HEX NUT, KEPS, NI	2
21	8158800	MS RD HD PH 10-24 X 1/2	1	42	8825300	DECAL, LEG	1





## HEAVY DUTY ELECTRIC FRYER OPERATION MANUAL

---

### BAKERS PRIDE LIMITED WARRANTY

<b>WHAT IS COVERED</b>	<p>This warranty covers defects in material and workmanship under normal use, and applies only to the original purchaser providing that:</p> <ul style="list-style-type: none"><li>• The equipment has not been accidentally or intentionally damaged, altered or misused;</li><li>• The equipment is properly installed, adjusted, operated and maintained in accordance with National and local codes and in accordance with the installation instruction provided with the product;</li><li>• The serial number rating plate affixed to the equipment has not been defaced or removed.</li></ul>
<b>WHO IS COVERED</b>	<p>This warranty is extended to the original purchaser and applies only to equipment purchased for use in the U.S.A.</p>
<b>COVERAGE PERIOD</b>	<p>Cyclone Convection Ovens: BCO Models: One (1) Year limited parts and labor; (1) Year limited door warranty. GDCO Models: Two (2) Year limited parts and labor; (2) Year limited door warranty. CO11 Models: Two (2) Year limited parts and labor; (5) Year limited door warranty. All Other Products: One (1) Year limited parts and labor. Warranty period begins the date of dealer invoice to customer or ninety (90) days after shipment date from Bakers Pride - whichever comes first.</p>
<b>WARRANTY</b>	<p>This warranty covers on-site labor, parts and reasonable travel time and travel expenses of the authorized service</p>
<b>COVERAGE</b>	<p>representative up to (100) miles, round trip, and (2) hours travel time. The purchaser, however, shall be responsible for all expenses related to travel, including time, mileage and shipping expenses on smaller counter models that may be carried into a Factory Authorized Service Center, including the following models: PX-14, PX-16, P18, P22S, P24S, PD-4, PDC, WS Series and BK-18.</p>
<b>EXCEPTIONS</b>	<p>All removable parts in Bakers Pride® cooking equipment, including but not limited to: Burners, Grates, Radiants, Stones and Valves, are covered for a period of SIX MONTHS. All Ceramic Baking Decks are covered for a period of THREE MONTHS. The installation of these replacement decks is the responsibility of the purchaser. The extended Cyclone door warranty years 3 through 5 is a parts only warranty and does not include labor, travel, mileage or any other charges.</p>
<b>EXCLUSIONS</b>	<ul style="list-style-type: none"><li>• Negligence or acts of God,</li><li>• Failures caused by erratic voltages or gas supplies,</li><li>• Thermostat calibrations after (30) days from equipment installation date,</li><li>• Unauthorized repair by anyone other than a Bakers Pride Factory Authorized Service Center,</li><li>• Air and Gas adjustments,</li><li>• Damage in shipment,</li><li>• Light bulbs,</li><li>• Alteration, misuse or improper installation,</li><li>• Glass doors and door adjustments,</li><li>• Thermostats and safety valves with broken capillary tubes,</li><li>• Fuses,</li><li>• Char-broiler work decks and cutting boards,</li><li>• Tightening of conveyor chains,</li><li>• Adjustments to burner flames and cleaning of pilot burners,</li><li>• Tightening of screws or fasteners.</li><li>• Accessories — spatulas, forks, steak turners, grate lifters, oven brushes, scrapers, peels. etc.,</li><li>• Freight — other than normal UPS charges,</li><li>• Ordinary wear and tear.</li></ul>
<b>INSTALLATION</b>	<p>Leveling and installation of decks as well as proper installation and check out of all new equipment —per appropriate installation and use materials — is the responsibility of the dealer or installer, not the manufacturer.</p>
<b>REPLACEMENT PARTS</b>	<p>Bakers Pride genuine Factory OEM parts receive a (90) day materials warranty effective from the date of installation by a Bakers Pride Factory Authorized Service Center.</p>

This Warranty is in lieu of all other warranties, expressed or implied, and all other obligations or liabilities on the manufacturer's part. Bakers Pride shall in no event be liable for any special, indirect or consequential damages, or in any event for damages in excess of the purchase price of the unit. The repair or replacement of proven defective parts shall constitute a fulfillment of all obligations under the terms of this warranty.

# Standex

Food Service Equipment Group

The Standex Food Service Equipment Group (FSEG) is a manufacturer of innovative commercial food service equipment offering a wealth of refrigeration and cooking expertise. Products include walk-in coolers and freezers; hot and cold display cabinets, cases, and storage systems; commercial ovens, rotisseries, and cooking equipment; and rotary vane pumps.

Ask your sales representative about how the power of all Standex brands can work for you.  
[www.standex.com/segments/food-service](http://www.standex.com/segments/food-service)

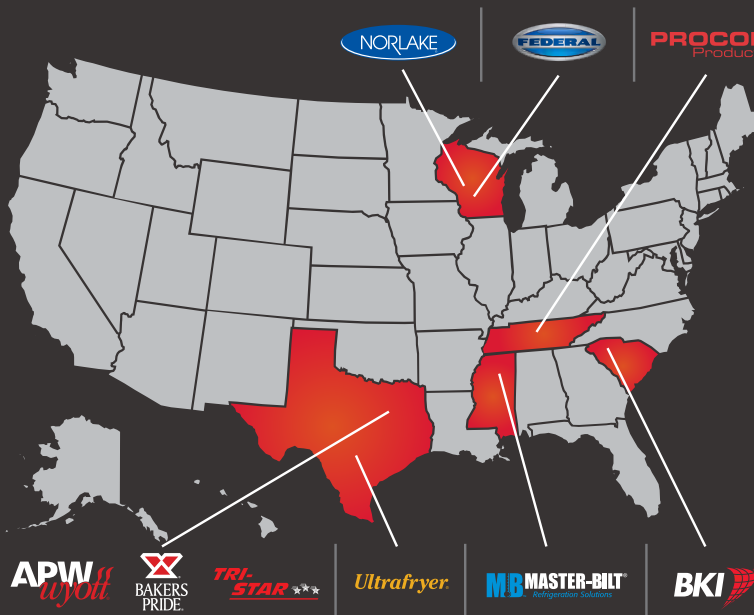

Be sure to keep up with new product announcements and events on social media!

