

Countertop Rotisserie Oven

MODEL FS

Service Manual

Serial Numbers 122912 and Higher



BKI LIMITED WARRANTY

2812 Grandview Dr. • Simpsonville, SC 29680 • USA
(864) 963-3471 • Toll Free: (800) 927-6887 • Fax: (864) 963-5316

WHAT IS COVERED

This warranty covers defects in material and workmanship under normal use, and applies only to the original purchaser providing that:

- ☐ The equipment has not been accidentally or intentionally damaged, altered or misused;
- ☐ The equipment is properly installed, adjusted, operated and maintained in accordance with national and local codes, and in accordance with the installation and operating instructions provided with this product.
- ☐ The serial number rating plate affixed to the equipment has not been defaced or removed.

WHO IS COVERED

This warranty is extended to the original purchaser and applies only to equipment purchased for use in the U.S.A.

COVERAGE PERIOD

- ☐ Warranty claims must be received in writing by BKI within one (1) year from date of installation or within one (1) year and three (3) months from data of shipment from the factory, whichever comes first.
- ☐ COB Models: One (1) Year limited parts and labor.
- ☐ COM Models: Two (2) Year limited parts and labor. COM convection ovens also have a two (2) year door warranty.
- ☐ CO1 Models: Two (2) Year limited parts and labor. Five (5) Year limited door warranty.
- ☐ BevLes Products: Two (2) Year limited parts and labor.
- ☐ Warranty period begins the date of dealer invoice to customer or ninety (90) days after shipment date from BKI, whichever comes first.

WARRANTY COVERAGE

This warranty covers on-site labor, parts and reasonable travel time and travel expenses of the authorized service representative up to (100) miles round trip and (2) hours travel time and performed during regular, weekday business hours.

EXCEPTIONS

Any exceptions must be pre-approved in advance and in writing by BKI. The extended door warranty on convection ovens years 3 through 5 is a parts only warranty and does not include labor, travel, mileage or any other charges.

EXCLUSIONS

- ☐ Negligence or acts of God,
- ☐ Thermostat calibrations after (30) days from equipment installation date,
- ☐ Air and gas adjustments,
- ☐ Light bulbs,
- ☐ Glass doors and door adjustments,
- ☐ Fuses,
- ☐ Adjustments to burner flames and cleaning of pilot burners,
- ☐ Tightening of screws or fasteners,
- ☐ Failures caused by erratic voltages or gas suppliers,
- ☐ Unauthorized repair by anyone other than a BKI Factory Authorized Service Center,
- ☐ Damage in shipment,
- ☐ Alteration, misuse or improper installation,
- ☐ Thermostats and safety valves with broken capillary tubes,
- ☐ Freight - other than normal UPS charges,
- ☐ Ordinary wear and tear,
- ☐ Failure to follow installation and/or operating instructions,
- ☐ Events beyond control of the company.

INSTALLATION

Leveling, as well as proper installation and check out of all new equipment - per appropriate installation and use materials - is the responsibility of the dealer or installer, not the manufacturer.

REPLACEMENT PARTS

BKI genuine Factory OEM parts receive a (90) day materials warranty effective from the date of installation by a BKI Factory Authorized Service Center.

Table of Contents

Table of Contents	1
Introduction	2
Safety Precautions.....	2
Safety Signs and Messages.....	2
Safe Work Practices.....	3
Health And Sanitation Practices.....	4
Food Handling.....	4
Storage Of Raw Meats.....	4
Coding Cooked Foods.....	4
Storage Of Prepared Foods.....	4
Safety Labels.....	5
Installation	6
Unpacking and Handling.....	6
Location and Clearance.....	6
Wiring.....	6
Replacement Parts	7
Assemblies.....	7
Components.....	22
Accessories.....	24
Wiring Diagrams	25
Notes	31

Introduction

The FS is single revolving mild air convection countertop oven. It utilizes a single revolving rotor system to ensure even product cooking. The unit contains a single stage cook and hold computer with 5 customizable cook programs. Electronic controls are provided for powering the unit, turning on inside lights, turning the rotors and resetting the unit. The rotors are removable to allow for easy maintenance and cleaning.

The **BKI** name and trademark on this unit assures you of the finest in design and engineering -- that it has been built with care and dedication -- using the best materials available. Attention to the operating instructions regarding proper installation, operation, and maintenance will result in long lasting dependability to ensure the highest profitable return on your investment.

NOTICE

PLEASE READ THIS ENTIRE MANUAL BEFORE OPERATING THE UNIT. If you have any questions, please contact your **BKI** Distributor. If they are unable to answer your questions, contact the **BKI** Technical Service Department, toll free: 1-800-927-6887. Outside the U.S., call 1-864-963-3471.

Safety Precautions

Always follow recommended safety precautions listed in this manual. Below is the safety alert symbol. When you see this symbol on your equipment, be alert to the potential for personal injury or property damage.



Safety Signs and Messages

The following Safety signs and messages are placed in this manual to provide instructions and identify specific areas where potential hazards exist and special precautions should be taken. Know and understand the meaning of these instructions, signs, and messages. Damage to the equipment, death or serious injury to you or other persons may result if these messages are not followed.

⚠ DANGER

This message indicates an imminently hazardous situation which, if not avoided, will result in death or serious injury.

⚠ WARNING

This message indicates a potentially hazardous situation, which, if not avoided, could result in death or serious injury.

⚠ CAUTION

This message indicates a potentially hazardous situation, which, if not avoided, may result in minor or moderate injury. It may also be used to alert against unsafe practices.

NOTICE

This message is used when special information, instructions or identification are required relating to procedures, equipment, tools, capacities and other special data.

Safe Work Practices

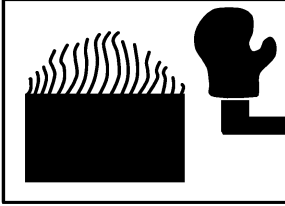

Wear Safe Clothing Appropriate To Your Job

Always wear your insulated mitts when handling hot racks or touch any hot metal surface. If you lose or damage your mitts, you can buy new ones at your local restaurant equipment supply store or from your local **BKI** Distributor.

Always wear non-skid shoes when working around the oven or any other equipment.

Never wear loose clothing such as neckties or scarves while operating this equipment. Keep loose hair tied back or in a hair net while operating this equipment.

Always wear appropriate personal protection equipment during the cleaning process to guard against possible injury from hot cleaning solution.

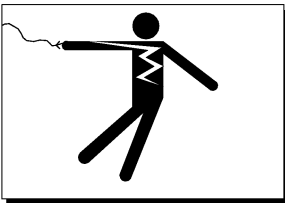

Beware of High Voltage

This equipment uses high voltage. Serious injury can occur if you or any untrained or unauthorized person installs, services, or repairs this equipment. Always Use an Authorized Service agent to Service Your Equipment.



Keep this manual with the Equipment

This manual is an important part of your equipment. Always keep it near for easy access. If you need to replace this manual, contact:

BKI

Technical Services Department
2812 Grandview Drive
Simpsonville, S.C. 29680
Or call toll free: 1-800-927-6887
Outside the U.S., call 864-963-3471



Protect Children

Keep children away from this equipment. Children may not understand that this equipment is dangerous for them and others.

NEVER allow children to play near or operate your equipment.

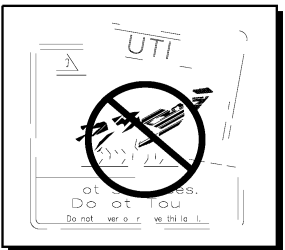

Keep Safety Labels Clean and in Good Condition

Do not remove or cover any safety labels on your equipment. Keep all safety labels clean and in good condition. Replace any damaged or missing safety labels. Refer to the Safety Labels section for illustration and location of safety labels on this unit. If you need a new safety label, obtain the number of the specific label illustrated on page 5, then contact:

BKI

Technical Services Department
2812 Grandview Drive
Simpsonville, S.C. 29680
Or call toll free: 1-800-927-6887
Outside the U.S., call 864-963-3471

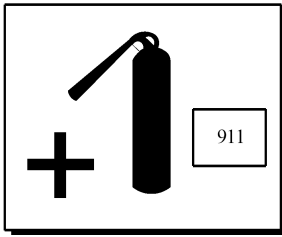

Be Prepared for Emergencies

Be prepared for fires, injuries, or other emergencies.

Keep a first aid kit and a fire extinguisher near the equipment. You must use a 40-pound Type BC fire extinguisher and keep it within 25 feet of your equipment.

Keep emergency numbers for doctors, ambulance services, hospitals, and the fire department near your telephone.

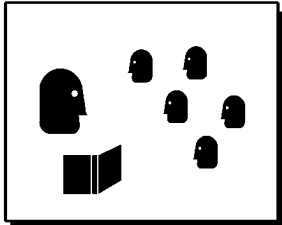

Know your responsibilities as an Employer

- Make certain your employees know how to operate the equipment.
- Make certain your employees are aware of the safety precautions on the equipment and in this manual.
- Make certain that you have thoroughly trained your employees about operating the equipment safely.
- Make certain the equipment is in proper working condition. If you make unauthorized modifications to the equipment, you will reduce the function and safety of the equipment.

Health And Sanitation Practices

BKI Rotisserie Ovens are manufactured to comply with health regulations and are tested and certified to NSF standards. You must operate the equipment properly, using only quality products and use meat thermometers to insure meats are thoroughly cooked.

Food Handling

- Wash hands thoroughly in warm, soapy water after handling raw poultry or meats.
- Clean and sanitize all utensils and surfaces that have been in contact with raw products. Clean and sanitize the meat forks or baskets between cooking.
- **Never** place cooked meats on the same surfaces used to prepare raw meats, unless the area has been thoroughly cleaned and sanitized.

Storage Of Raw Meats

- Designate an area or shelf strictly for the storage of all raw meats to be used in the rotisserie.
- Raw product must always be stored at temperatures below 38° F. (3° C.).
- **Never** store or mix raw foods above cooked foods, as this is a health hazard. The drippings from raw foods contaminate cooked or processed foods.
- All chicken and chicken parts to be stored overnight must be thoroughly iced down and refrigerated.

Coding Cooked Foods

All products cooked during the day should be sold the same day.

NOTE: It is not the intent of the rotisserie program to have unsold merchandise at the end of the cooking day. Follow your company's procedures for the handling of any leftover product.

Storage Of Prepared Foods

- Cold foods should be kept at or below 38° F. (3° C.).
- Hot foods must be maintained to meet local health codes, usually a minimum 145° F. (63° C.).

Safety Labels



Installation

⚠ WARNING

Serious injury, equipment damage or death could result if attempting to install this oven yourself. Ensure that an authorized BKI service agent installs the oven.

Unpacking and Handling

It is the owners' responsibility to file all freight claims with the delivering truck line. Inspect all cartons and crates for damage as soon as they arrive. If damage to cartons or crates is found, or if a shortage is found, note this on the bill of lading (all copies) prior to signing.

If damage is found when the equipment is opened, immediately call the delivering truck line and follow up the call with a written report indicating concealed damage to your shipment. Ask for an immediate inspection of your concealed damage item. Packaging material **MUST** be retained to show the inspector from the truck line.

Remove all packing from the interior and exterior of the oven.

Location and Clearance

Underwriters Laboratories requires that the oven have at least 6" clearance from combustible surfaces at the rear of the machine.

Wiring

⚠ WARNING

Electrocution, equipment failure or property damage could result if an unlicensed electrician performs the electrical installation. Ensure that a licensed electrician perform the electrical installation in accordance with local codes, or in the absence of local codes, with the National Electrical Code, ANSI NFPA 70-20XX.

This unit, when installed by an authorized BKI service agent, must be wired for use in accordance with all applicable local, state, and federal codes. For specific electrical requirements and connections refer to the wiring diagram attached to the unit or provided in the Service Manual.

Replacement Parts

Use the information in this section to identify replacement parts. To order replacement parts, call your local **BKI** sales and service representative. Before calling, please note the serial number on the rating tag affixed to the unit.

Assemblies

Description	Assembly #	Figure #	Table #	Page #
DRIP PAN	SB5242	Figure 1	Table 1	8
BASE	SB5236 SB5255	Figure 2	Table 2	10
CONTROL PANEL	SB5262 SB5252 SB5241 SB5263 SB5265	Figure 3	Table 3	12
DOOR	SB5243	Figure 4	Table 4	14
INSIDE TOP	SB5237 SB5254	Figure 5	Table 5	16
ROTOR SYSTEM SHAFT & PULLEY WELDMENT PLAIN SIDE ROTOR SPRING SIDE ROTOR	SB5211 SB5258 SB5259	Figure 6	Table 6	18
INSIDE CABINET	SB5238	Figure 7	Table 7	20

Figure 1. Drip Pan

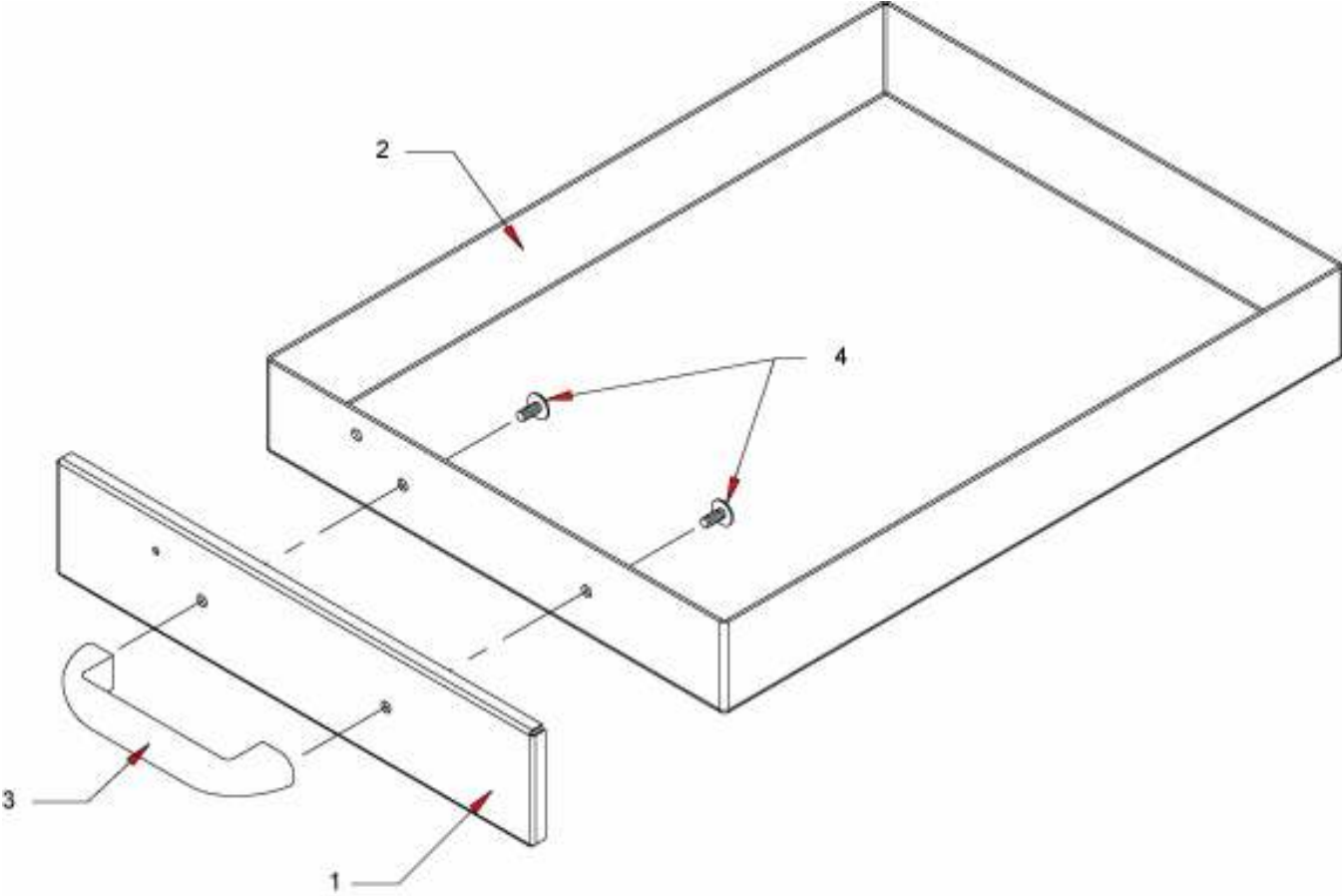

Table 1. Drip Pan Parts

ITEM #	PART #	QTY	DESCRIPTION
1	FSA054	1	COVER PLATE, DRIP PAN FS
2	WFSA059	1	DRIP PAN, FS WELDED
3	H0201	1	HANDLE, LID
4	SCR274	2	SCREW, 8-32 X 1/4 SLTD PAN

Figure 2. Base

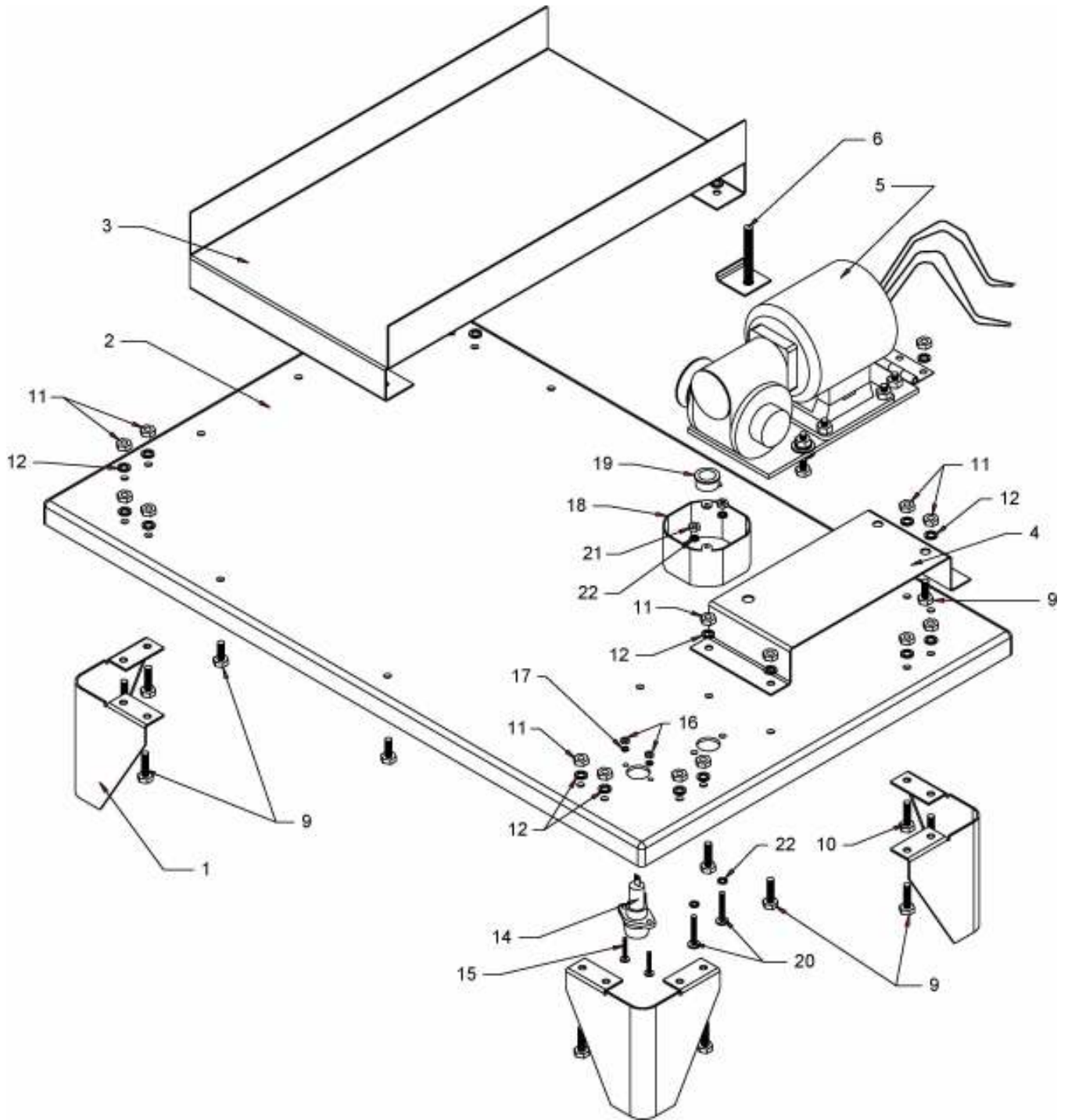

Table 2. Base Parts

ITEM #	PART #	QTY	DESCRIPTION
1	FSA074B	4	LEG, FS PAINTED BLACK
2	WFSA060	1	BASE, FS CORNERS WELDED
3	FSA065	1	DRIP PAN SUPPORT
4	FSA075	1	MOTOR MOUNT SUPPORT
5	SB5208 or SB5223	1	MOTOR MOUNT ASSY, 120V FS or MOTOR MOUNT ASSY, FS
6	SB0212	1	MTG PLATE & SCREW WELD ASSY
7	WSH041 *	1	WASHER, 3/8 USS FLAT
8	NUT096 *	1	NUT, 3/8-16 STOVER LOCK
9	SCR059	22	SCREW, 1/4-20 X 3/4 HEX CAP
10	SCR060	2	SCREW, 1/4-20 X 1 HEX CAP
11	NUT053	24	NUT, 1/4-20 HEX HEAVY ZINC PLT
12	WSH044	24	WASHER, 1/4 LOCK ZINC PLTD
13	F0097 *	1	FUSE, 15A 300V SC15 TIME DELAY
14	FH0001	1	FUSE HOLDER, 15A 300V HPF-EE
15	SCR323	2	SCREW, 6-32 X 1/2 PHIL RD
16	NUT048	2	NUT, 6-32 HEX ZINC PLTD
17	WSH089	2	WASHER, #6 INT LOCK ZINC PLATED
18	OB0001	1	BOX, OUTLET OCTAGON 1/2 KO
19	F0155	2	BUSHING, BLK 7/8 HEYCO SNAP
20	SCR162	2	SCREW, 10-24 X 1 SLTD RD
21	NUT051	2	NUT, 10-24 HEX ZINC PLTD
22	WSH037	4	WASHER, 3/16 SAE FLAT

* - Not Shown

Figure 3. Control Panel

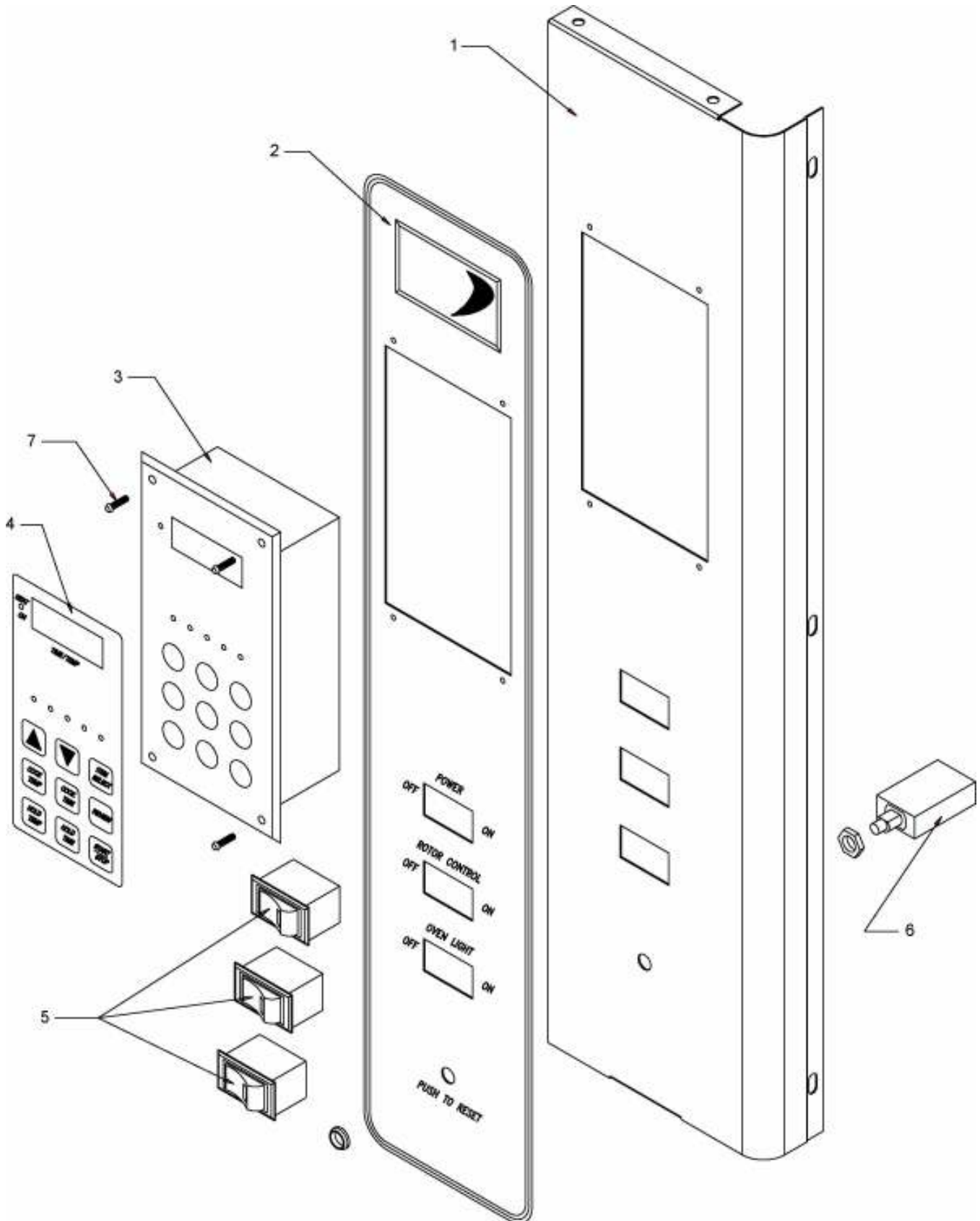

Table 3. Control Panel Parts

ITEM #	PART #	QTY	DESCRIPTION
1	FSA061	1	CONTROL PANEL, W/O SMOKE
2	N0388	1	DECAL, CONTROL PANEL FS
3	CP0022	1	CONTROLLER, DIGT TEMP/TIME
4	N0389	1	DECAL, CONTROLLER OVERLAY (CP0022)
5	S0107	3	SWITCH, RKR SPST 15A 125V LAMP
6	CB0050	1	BREAKER, CIRCUIT 3 AMP 250V
7	SCR006	4	SCREW, 8 X 1/2 PHIL PAN
8	R0002 * or R0004 *	1	RELAY, 2 POLE 110/120V or RELAY, 2 POLE 208/240V

* - Not Shown

Figure 4. Door

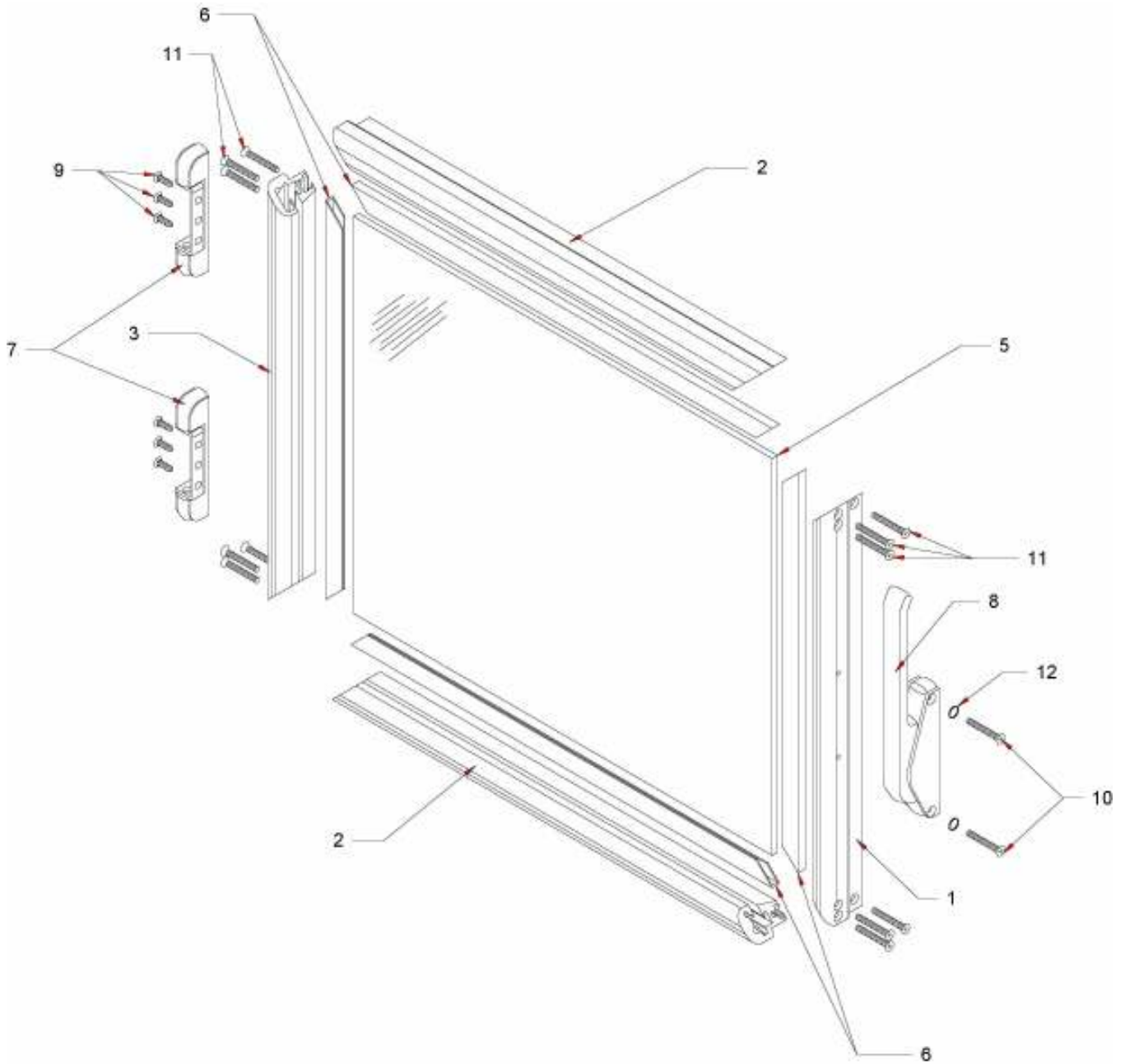

Table 4. Door Parts

ITEM #	PART #	QTY	DESCRIPTION
1	FSA089	1	DOOR STOCK, EA0082 16.625
2	FSA087	2	DOOR STOCK, FS EA0081 20.125
3	FSA088	1	DOOR STOCK, EA0082 16.625
4	G0302 *	6.021 ft.	GASKET, SILICONE MACHINE
5	GL0105	1	GLASS, 15 15/16 X 19 7/16
6	GT0003	5.896 ft.	GASKET, GLASS FS
7	H0001	2	HINGE, DOOR 7/8 OFFSET
8	L0110	1	LATCH, KASON #544, MAGNETIC
9	SCR014	6	SCREW, 10 X 3/4 PHIL FLT UNDERCUT
10	SCR020	2	SCREW, 10 X 1 1/2 PHIL OVAL
11	SCR197	12	SCREW, 10-24 X 1 1/2 PHIL FL
12	WSH254	2	WASHER, #10 INT TOOTH

* - Not Shown

Figure 5. Inside Top

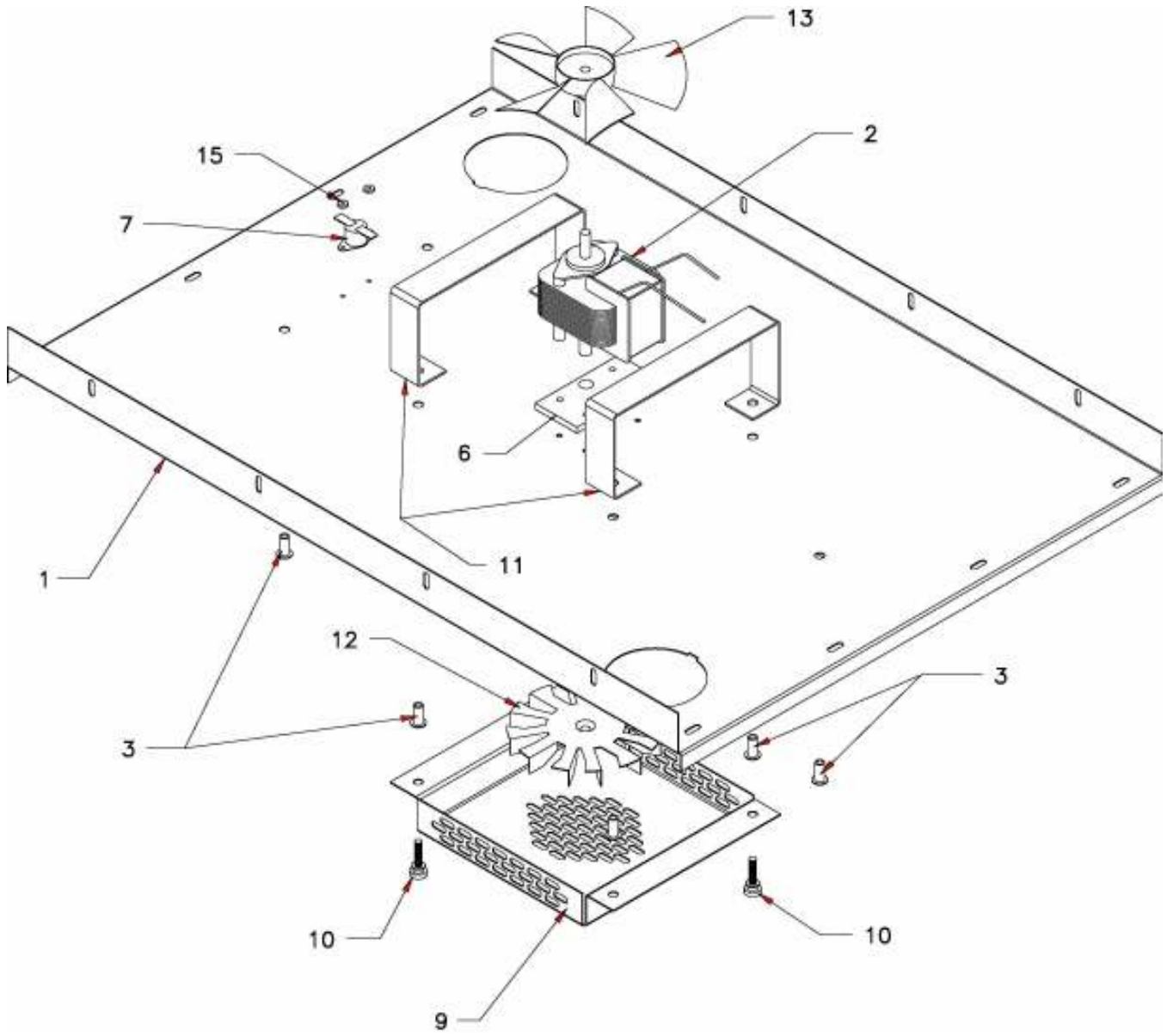

Table 5. Inside Top Parts

ITEM #	PART #	QTY	DESCRIPTION
1	FSA053	1	INSIDE TOP, FS ECO PENDING 5-20-98
2	M0063 or M0068	1	MOTOR, 120V SHADED POLE 5A143-30 MOTOR, 208/240V 60 HZ 5A143-33
3	F0083	7	THREAD INSERT 10-24 STEEL
4	SCR118 *	4	SCREW, 6-32 X 5/8 SLTD RD
5	WSH089 *	4	WASHER, #6 INT LOCK ZINC PLATED
6	FA10513718 or HB0001	1	HEAT BARRIER PLATE MSR or HEAT BARRIER, MSR 1 1/2 X 3
7	S0115	1	SWITCH, OVERTEMPERATURE
8	F0243 *	2	TERMINAL, 1/4" QUICK CONNECT
9	FSA073	1	FAN SHROUD
10	SCR121	4	SCREW, 10-24 X 3/4 KNURLED BRT
11	FSA057	2	FAN OFFSET SUPPORT
12	FN0021	1	FAN BLADE, 4" METAL 4-HF.250-Y
13	FN0022	1	FAN BLADE, 5" RHF .250-O
14	SCR219 *	2	SCREW, 4-40 X 3/8 PHIL PAN
15	NUT180 *	2	NUT, 4-40 WASHER LOCKNUT

* - Not Shown

Figure 6. Rotor System Assembly

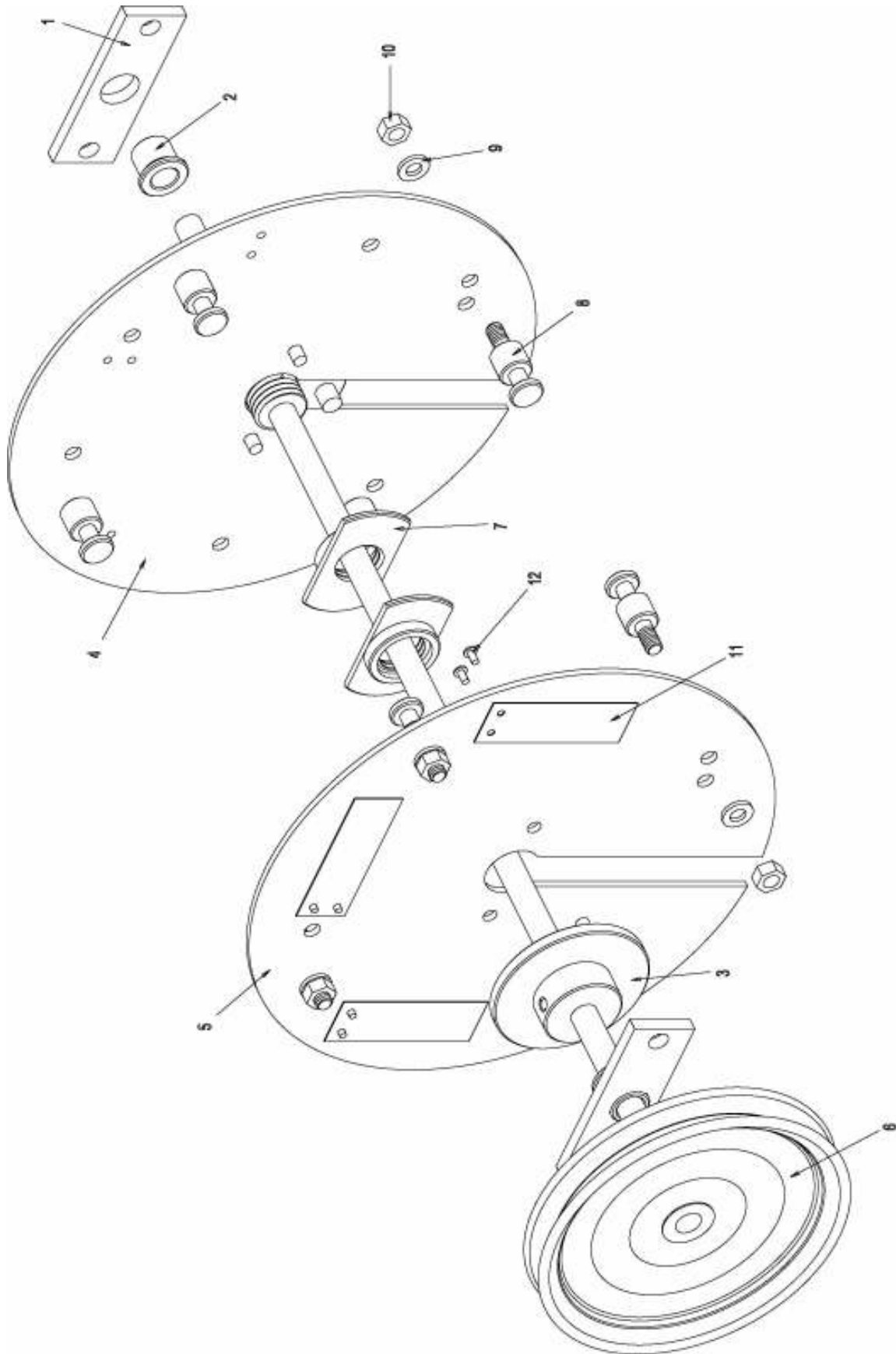

Table 6. Rotor System Parts

ITEM #	PART #	QTY	DESCRIPTION
1	LMWSA018	2	BEARING BLOCK
2	B0203	2	BUSHING, 3/4" ROTOR TZ001281
3	H0100	2	HUB, QUIK RELEASE (FS)
4	SB5258	1	ROTOR ASSY, FS PLAIN SIDE
5	SB5259	1	ROTOR ASSY, FS SPRING SIDE
6	SB5211	1	SHAFT & PULLEY WELD ASSY, FS
7	H0101	2	HUB SPINNER, QUIK RELEASE FS
8	P0060	4	PIN, DISC ROTOR STANDOFF
9	WSH045	4	WASHER, 5/16 LOCK ZINC PLTD
10	NUT055	4	NUT, 5/16-18 FINISHED HEX
11	S0033	3	SPRING, ROTOR
12	RIV172	6	RIVET, 1/8 CS ZINC (.187-.250)

Figure 7. Inside Cabinet

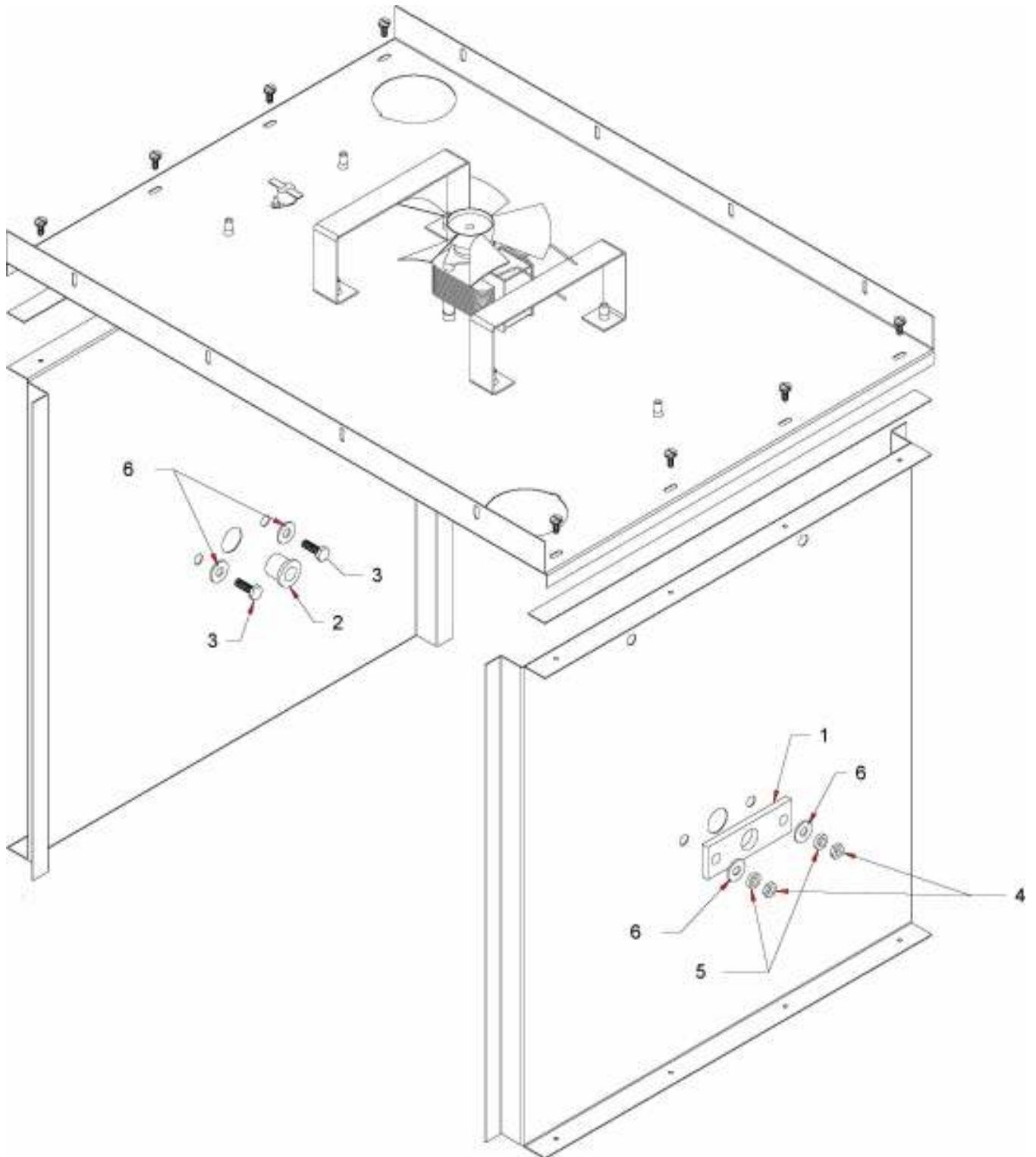

Table 7. Inside Cabinet Parts

ITEM #	PART #	QTY	DESCRIPTION
1	LMWSA018	2	BEARING BLOCK
2	B0203	2	BUSHING, 3/4" ROTOR TZ001281
3	SCR059	4	SCREW, 1/4-20 X 3/4 HEX CAP
4	NUT053	4	NUT, 1/4-20 HEX HEAVY ZINC PLT
5	WSH044	4	WASHER, 1/4 LOCK ZINC PLTD
6	WSH040	8	WASHER, 5/16 USS FLAT

Components



Description	QTY	Part #	Item #
BULB, TUFFSKIN 40W 250V	2	B0553	
CALROD, 120V 2800W CALROD, 208V 2800W CALROD, 240V 2800W	1	C0036 C0037 C0038	
LAMPHOLDER W/BULB 120V 40W	2	LH0019	
THERMOCOUPLE, TYPE K T-2016	1	T0085	
TRANSFORMER, 120-24V LGF	1	TF0005	
TRANSFORMER, 240-24V LGF	1	TF0030	

Countertop Rotisserie Oven

Replacement Parts

Description	QTY	Part #	Item #
V-BELT, 4L-300	1	VB0002	

Accessories

Description	Part #	Item #
INSULATED MITT 13"	G0052	
BASKET, MEAT FS	MB0007	
MEAT FORK 20 3/4" LMWS	MF0002	

Wiring Diagrams

Description	Assembly #	Figure #
120V/1 Phase	FSE1013	Figure 8
120V/208V/1 Phase	FSE1014	Figure 9
208-220V/240V/1 Phase	FSE1019	Figure 10
220V/240V/50HZ/1 Phase	FSE1021	Figure 11
230V/50HZ/1 Phase	FSE1020	Figure 12

Figure 8. 120V/1 Phase

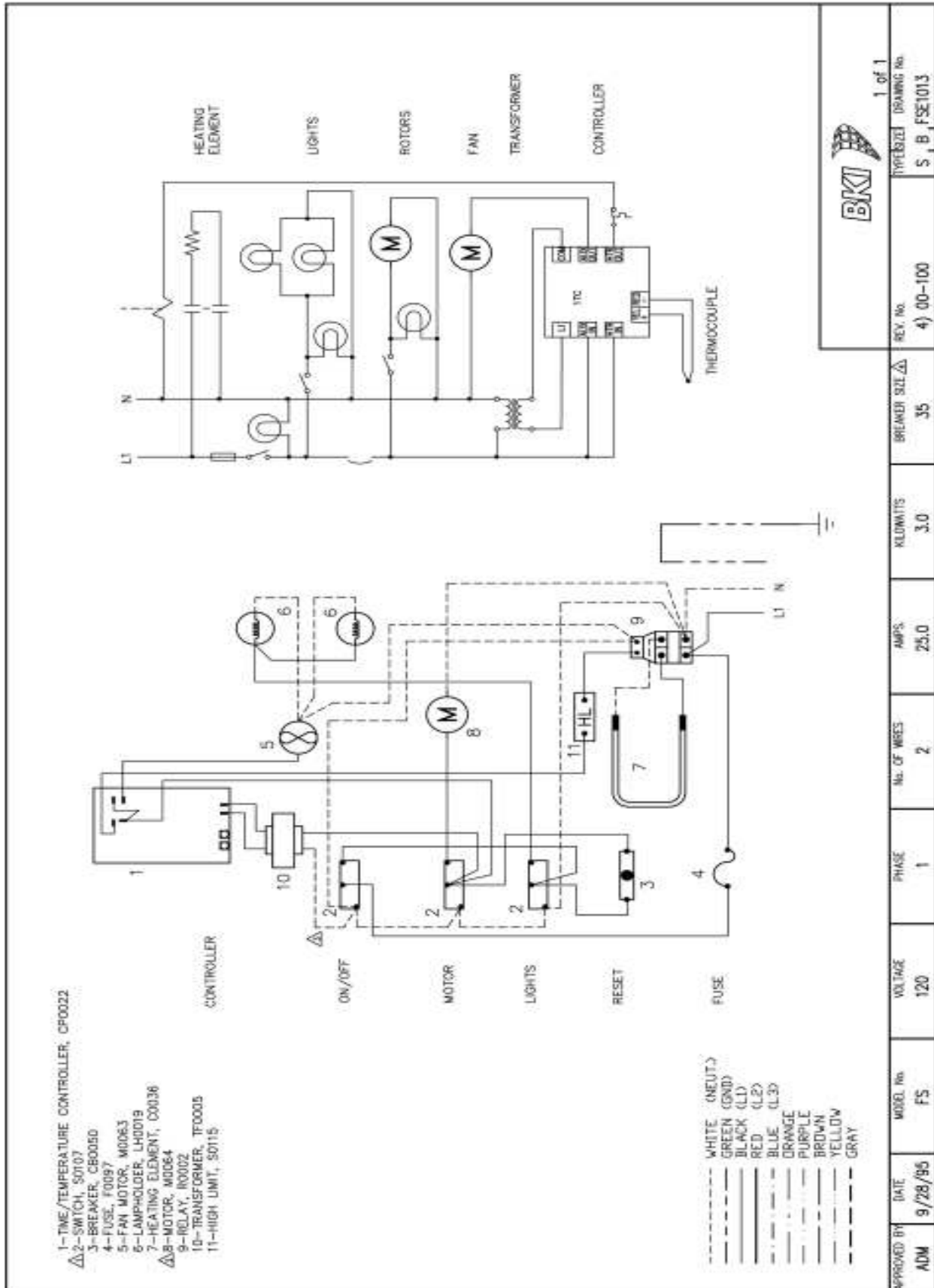
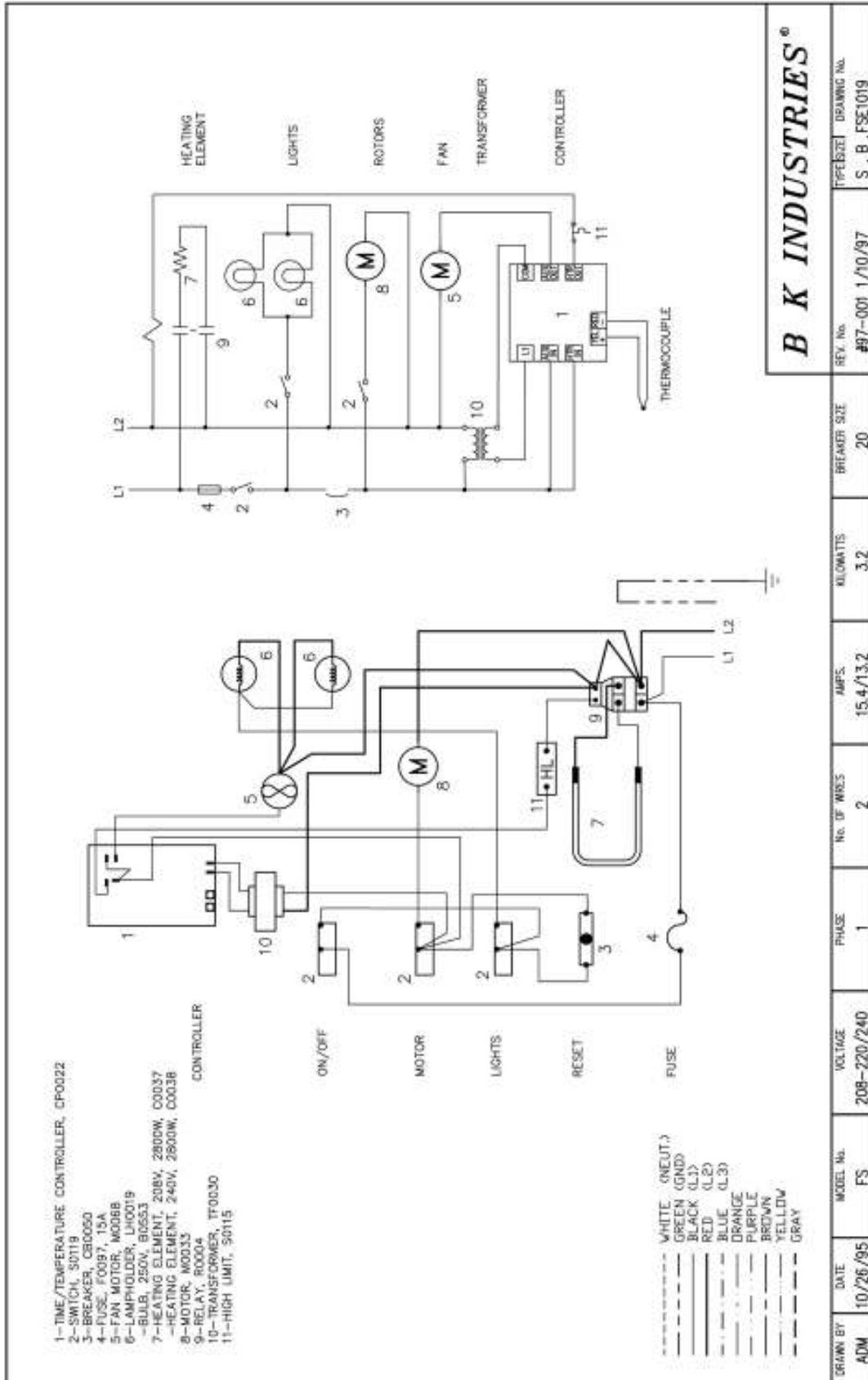
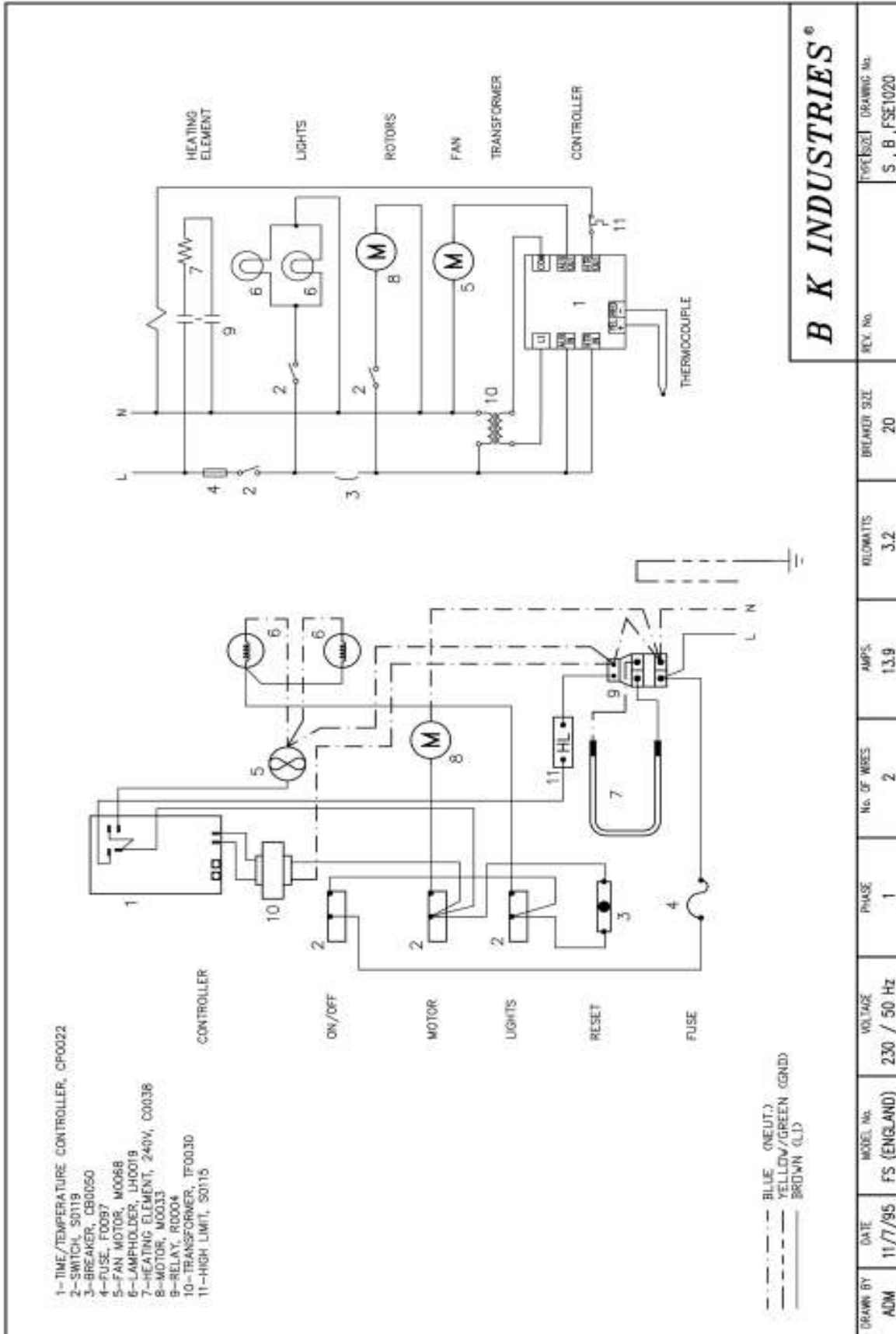

Figure 10. 208-220V/240V/1 Phase



B K INDUSTRIES®

Figure 12. 230V/50HZ/1 Phase



Notes



2812 Grandview Dr., Simpsonville, S.C. 29680, USA
<http://www.bkideas.com>

Made and printed in the U.S.A
LI0261/0407

CS-TM-024.01

Revised 3/26/13

REVISION HISTORY

<u>REVISION</u>	<u>DATE</u>	<u>REVISED BY</u>	<u>DESCRIPTION</u>
01	03/26/13	KW	Initial Release-Supersedes all previous releases