

Doughnut Fryer

MODELS DNF, DNF-F

Service Manual

Serial Numbers 123439 and higher



BKI LIMITED WARRANTY

2812 Grandview Dr. • Simpsonville, SC 29680 • USA
(864) 963-3471 • Toll Free: (800) 927-6887 • Fax: (864) 963-5316

WHAT IS COVERED

This warranty covers defects in material and workmanship under normal use, and applies only to the original purchaser providing that:

- ☒ The equipment has not been accidentally or intentionally damaged, altered or misused;
- ☒ The equipment is properly installed, adjusted, operated and maintained in accordance with national and local codes, and in accordance with the installation and operating instructions provided with this product.
- ☒ The serial number rating plate affixed to the equipment has not been defaced or removed.

WHO IS COVERED

This warranty is extended to the original purchaser and applies only to equipment purchased for use in the U.S.A.

COVERAGE PERIOD

- ☒ Warranty claims must be received in writing by BKI within one (1) year from date of installation or within one (1) year and three (3) months from data of shipment from the factory, whichever comes first.
- ☒ COB Models: One (1) Year limited parts and labor.
- ☒ COM Models: Two (2) Year limited parts and labor. COM convection ovens also have a two (2) year door warranty.
- ☒ CO1 Models: Two (2) Year limited parts and labor. Five (5) Year limited door warranty.
- ☒ BevLes Products: Two (2) Year limited parts and labor.
- ☒ Warranty period begins the date of dealer invoice to customer or ninety (90) days after shipment date from BKI, whichever comes first.

WARRANTY COVERAGE

This warranty covers on-site labor, parts and reasonable travel time and travel expenses of the authorized service representative up to (100) miles round trip and (2) hours travel time and performed during regular, weekday business hours.

EXCEPTIONS

Any exceptions must be pre-approved in advance and in writing by BKI. The extended door warranty on convection ovens years 3 through 5 is a parts only warranty and does not include labor, travel, mileage or any other charges.

EXCLUSIONS

- ☒ Negligence or acts of God,
- ☒ Thermostat calibrations after (30) days from equipment installation date,
- ☒ Air and gas adjustments,
- ☒ Light bulbs,
- ☒ Glass doors and door adjustments,
- ☒ Fuses,
- ☒ Adjustments to burner flames and cleaning of pilot burners,
- ☒ Tightening of screws or fasteners,
- ☒ Failures caused by erratic voltages or gas suppliers,
- ☒ Unauthorized repair by anyone other than a BKI Factory Authorized Service Center,
- ☒ Damage in shipment,
- ☒ Alteration, misuse or improper installation,
- ☒ Thermostats and safety valves with broken capillary tubes,
- ☒ Freight - other than normal UPS charges,
- ☒ Ordinary wear and tear,
- ☒ Failure to follow installation and/or operating instructions,
- ☒ Events beyond control of the company.

INSTALLATION

Leveling, as well as proper installation and check out of all new equipment - per appropriate installation and use materials – is the responsibility of the dealer or installer, not the manufacturer.

REPLACEMENT PARTS

BKI genuine Factory OEM parts receive a (90) day materials warranty effective from the date of installation by a BKI Factory Authorized Service Center.

Table of Contents

Table of Contents	1
Introduction	2
Safety Precautions	2
Safety Signs and Messages	2
Safe Work Practices	3
Safety Labels	7
Installation	8
Unpacking and Handling	8
Assembly and Mounting	8
Wiring	8
Initial Test and Adjustment.....	9
Replacement Parts	10
Assemblies & Components	10
Accessories	20
Wiring Diagrams	21
Notes	25

Introduction

The **BKI** Doughnut Fryer is intended for general commercial use. It consists of an oil vat, 2 electrical control panels, a manual drain control and an oil filter system (DNF-F only). The oil vat holds the cooking oil that is heated by tubular heating elements. The Lower Electrical Panel controls and indicates power to the unit as well as power to the filter system. This panel also contains 2 fuses that protect the circuitry within the unit. The Upper Electrical Panel contains a thermostat that regulates the oil temperature and a push button for resetting the heating elements in the event of an overtemperature condition. A drain control is provided behind the door to allow the user to drain the cooking oil for filtering purposes. The DNF-F comes with a built-in oil filter system consisting of an oil container, filter screen assembly and pump motor/piping necessary to filter cooking oil.

The BKI name and trademark on this unit assures you of the finest in design and engineering -- that it has been built with care and dedication -- using the best materials available. Attention to the operating instructions regarding proper installation, operation, and maintenance will result in long lasting dependability to insure the highest profitable return on your investment.

NOTICE

PLEASE READ THIS ENTIRE MANUAL BEFORE OPERATING THE UNIT. If you have any questions, please contact your BKI Distributor. If they are unable to answer your questions, contact the BKI Technical Service Department, toll free: 1-800-927-6887. Outside the U.S., call 1-864-963-3471.

Safety Precautions

Always follow recommended safety precautions listed in this manual. Below is the safety alert symbol. When you see this symbol on your equipment, be alert to the potential for personal injury or property damage.



Safety Signs and Messages

The following Safety signs and messages are placed in this manual to provide instructions and identify specific areas where potential hazards exist and special precautions should be taken. Know and understand the meaning of these instructions, signs, and messages. Damage to the equipment, death or serious injury to you or other persons may result if these messages are not followed.

⚠ DANGER

This message indicates an imminently hazardous situation which, if not avoided, will result in death or serious injury.

⚠ WARNING

This message indicates a potentially hazardous situation, which, if not avoided, could result in death or serious injury.

⚠ CAUTION

This message indicates a potentially hazardous situation, which, if not avoided, may result in minor or moderate injury. It may also be used to alert against unsafe practices.

NOTICE

This message is used when special information, instructions or identification are required relating to procedures, equipment, tools, capacities and other special data.

Safe Work Practices



Beware of High Voltage

This equipment uses high voltage. Serious injury can occur if you or any untrained or unauthorized person installs, services, or repairs this equipment. Always Use an Authorized Service agent to Service Your Equipment



Noncombustible Floors Only

Make sure your floor is noncombustible. Do not operate your fryer on floors that are wood, carpeted or have rubber mats.

- Placing your fryer on a combustible floor could cause a fire. Serious injury could result.
- Examples of noncombustible floors where you can safely place your fryer are concrete, tile, and ceramic.



Keep The Area Around Your Fryer Uncluttered

Make sure to keep the area around your fryer clear of any obstacles.

Serious injury can occur if you trip or fall near the fryer. You could be burned by hot shortening that splashes out of the fryer or by falling against the hot metal of the fryer.



Keep The Floor Around Your Fryer Clean Of Shortening

Make sure to keep the floor around your fryer clean of shortening and other liquids.

Serious injury can occur if you slip near your fryer. You could be burned by hot shortening that splashes out of the fryer or by falling against the hot metal of the fryer.



Keep The Lid Closed When The Fryer Is Not In Use

Hot shortening can splash if someone moves the fryer or bumps into it. Serious injury can occur if hot shortening splashes out of the fryer.

Do not lean, sit or stand on the fryer or perform any maintenance or cleaning duties while the fryer or the shortening is hot. You could be burned.

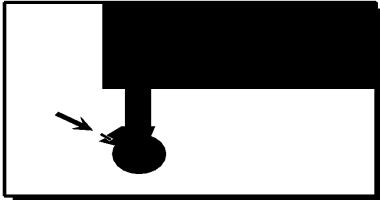

Keep The Casters Locked

To avoid spilling shortening, keep the casters locked. If any shortening spills near your fryer, clean it up immediately.

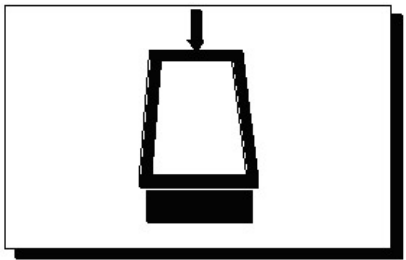

Do Not Overfill The Fryer With Shortening

Hot shortening and steam may escape and burn you if you put too much shortening in the fryer. Fill the fryer to approximately one inch below the fill marks that are inside the fryer vat. Heat the shortening. If needed, carefully add more shortening to bring the level to the fill marks.



Do Not Let Any Water Get Into The Fryer

Always remove excess moisture from food before placing it into the fryer vat. Water will cause the hot shortening to spatter. You could be burned.

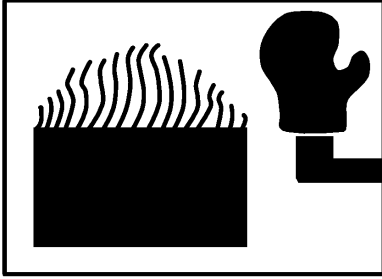
**Wear Safe Clothing Appropriate To Your Job**

Always wear your insulated mitts when handling the racks or touch any hot metal surfaces. You received a pair of insulated mitts with your fryer. If you lose or damage your mitts, you can buy new ones at your local restaurant equipment supply store or from your local **BKI** Distributor.

Always wear non-skid shoes when working around the fryer or any other equipment that uses shortening. Never wear loose clothing such as neckties or scarves while operating your fryer. Keep loose hair tied back or in a hair net while operating your fryer.

Always wear appropriate personal protection equipment during the filtering process to guard against possible injury from hot oil.

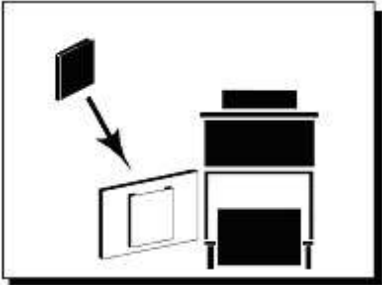
**Keep this manual with the Equipment**

This manual is an important part of your equipment. Always keep it near for easy access.

If you need to replace this manual, contact:

BKI

Technical Services Department
2812 Grandview Drive
Simpsonville, S.C. 29680
Or call toll free: 1-800-927-6887
Outside the U.S., call 864-963-3471

**Protect Children**

Keep children away from this equipment. Children may not understand that this equipment is dangerous for them and others.

NEVER allow children to play near or operate your equipment.

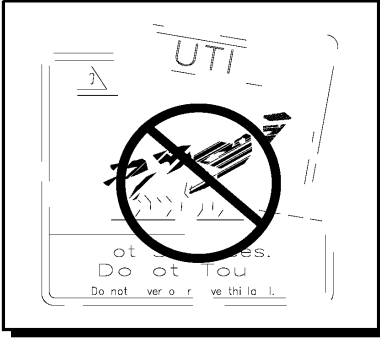

Keep Safety Labels Clean and in Good Condition

Do not remove or cover any safety labels on your equipment. Keep all safety labels clean and in good condition. Replace any damaged or missing safety labels. Refer to the Safety Labels section for illustration and location of safety labels on this unit.

If you need a new safety label, obtain the number of the specific label illustrated on page 7, then contact:

BKI

Technical Services Department
2812 Grandview Drive
Simpsonville, S.C. 29680
Or call toll free: 1-800-927-6887
Outside the U.S., call 864-963-3471

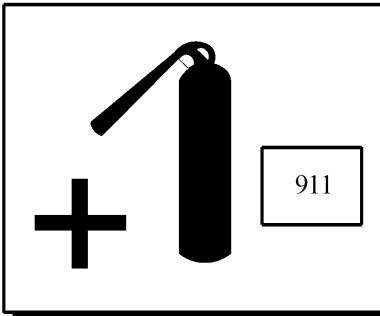

Be Prepared for Emergencies

Be prepared for fires, injuries, or other emergencies.

Keep a first aid kit and a fire extinguisher near the equipment. You must use a 40-pound Type BC fire extinguisher and keep it within 25 feet of your equipment.

Keep emergency numbers for doctors, ambulance services, hospitals, and the fire department near your telephone.

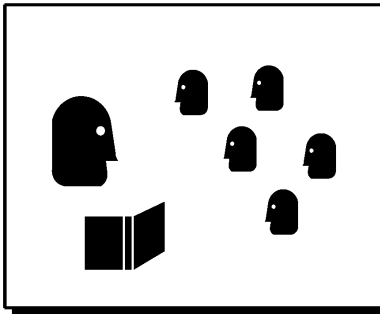

Know your responsibilities as an Employer

- Make certain your employees know how to operate the equipment.
- Make certain your employees are aware of the safety precautions on the equipment and in this manual.
- Make certain that you have thoroughly trained your employees about operating the equipment safely.
- Make certain the equipment is in proper working condition. If you make unauthorized modifications to the equipment, you will reduce the function and safety of the equipment.

Safety Labels

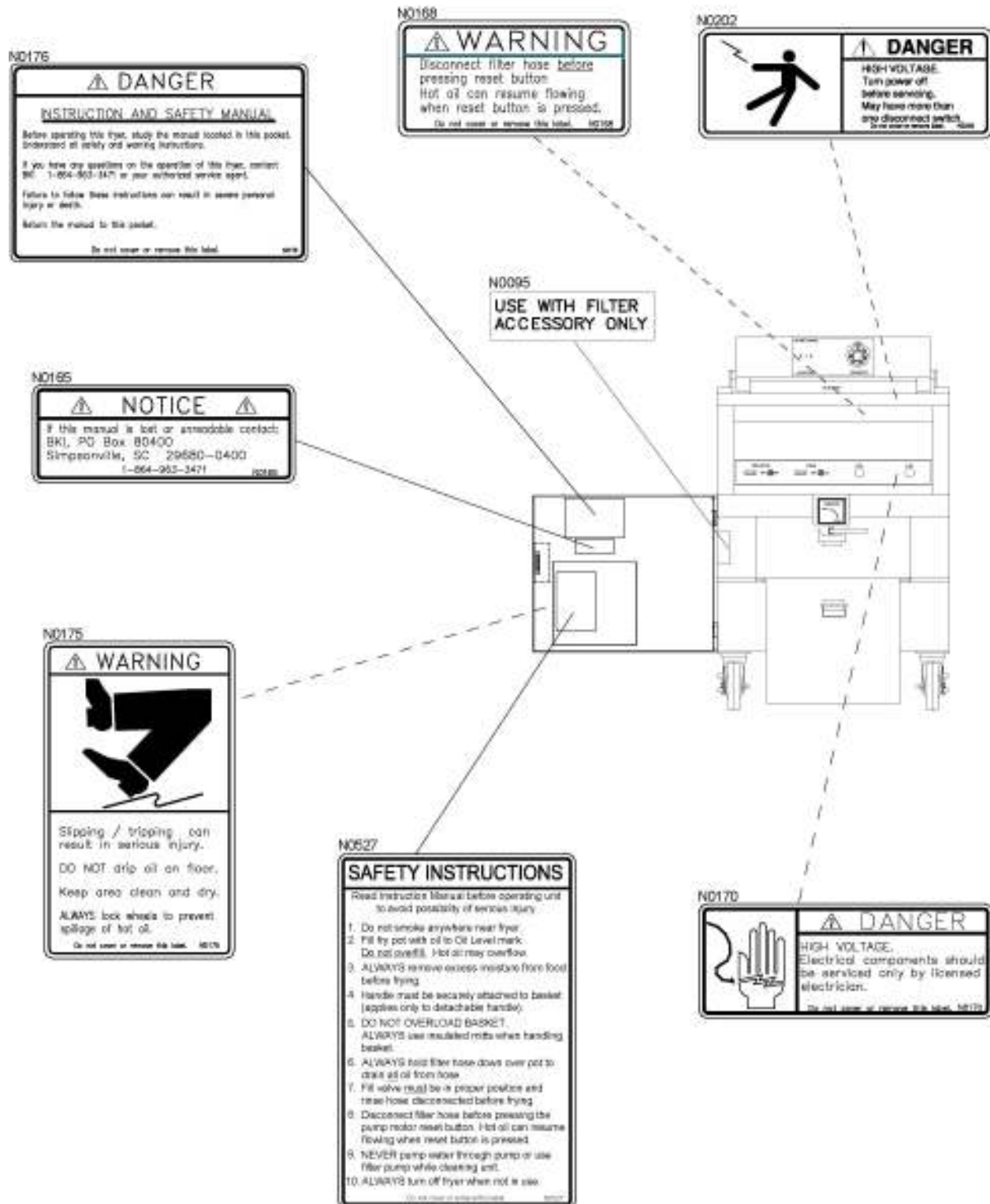

Installation

⚠ WARNING

Serious injury, equipment damage or death could result if attempting to install this fryer yourself. Ensure that an authorized BKI service agent installs the fryer.

Unpacking and Handling

It is the owners' responsibility to file all freight claims with the delivering truck line. Inspect all cartons and crates for damage as soon as they arrive. If damage to cartons or crates is found, or if a shortage is found, note this on the bill of lading (all copies) prior to signing.

If damage is found when the equipment is opened, immediately call the delivering truck line and follow up the call with a written report indicating concealed damage to your shipment. Ask for an immediate inspection of your concealed damage item. Packaging material **MUST** be retained to show the inspector from the truck line.

Assembly and Mounting

1. Remove all packing from the interior and exterior of the fryer.
2. Move the fryer to its permanent location and lock the casters so the fryer does not move. Every time you use the fryer, ensure that the casters are locked.
3. Clean the fryer vat before filling with shortening.
4. Place the DRAIN handle in the CLOSED position.
5. If you plan to cook cake doughnuts, attach the submersion screen ([R0019](#)) to the calrod shield ([DNFA007](#)).

Wiring

⚠ WARNING

Electrocution, equipment failure or property damage could result if an unlicensed electrician performs the electrical installation. Ensure that a licensed electrician perform the electrical installation in accordance with local codes, or in the absence of local codes, with the National Electrical Code, ANSI NFPA 70-20XX.

This unit, when installed by an authorized BKI service agent, must be wired for use in accordance with all applicable local, state, and federal codes. For specific electrical requirements and connections refer to the wiring diagram attached to the unit or provided in the Service Manual.

Initial Test and Adjustment

1. Fill vat with shortening to about one inch below the mark.

NOTE: A solid type vegetable shortening is recommended for frying because doughnuts tend to absorb more shortening and are heavy when fried in liquid shortening.

CAUTION

Overfilling the fryer vat with shortening could lead to serious injury. Ensure that the fryer vat is filled with shortening only to the fill mark when shortening is hot. Do not use any shortening other than what is specified in this manual and do not overfill the fryer vat.

NOTICE

Use only high-quality shortening that has low moisture content, a high smoke point and no additives.

2. Place the **POWER** switch to the **ON** position.
3. Set the thermostat to the desired temperature (best results are obtained at 370° F to 380° F). The shortening should begin to heat and begin to reach the fill mark inside the vat. Add more shortening as required to reach the fill mark. Refer to the troubleshooting section if this does not occur.

Replacement Parts

Use the information in this section to identify replacement parts. To order replacement parts, call your local BKI sales and service representative. Before calling, please note the serial number, model number and voltage on the rating tag affixed to the unit.

Assemblies & Components

Figure 1. DNF/DNF-F Assembly & Components

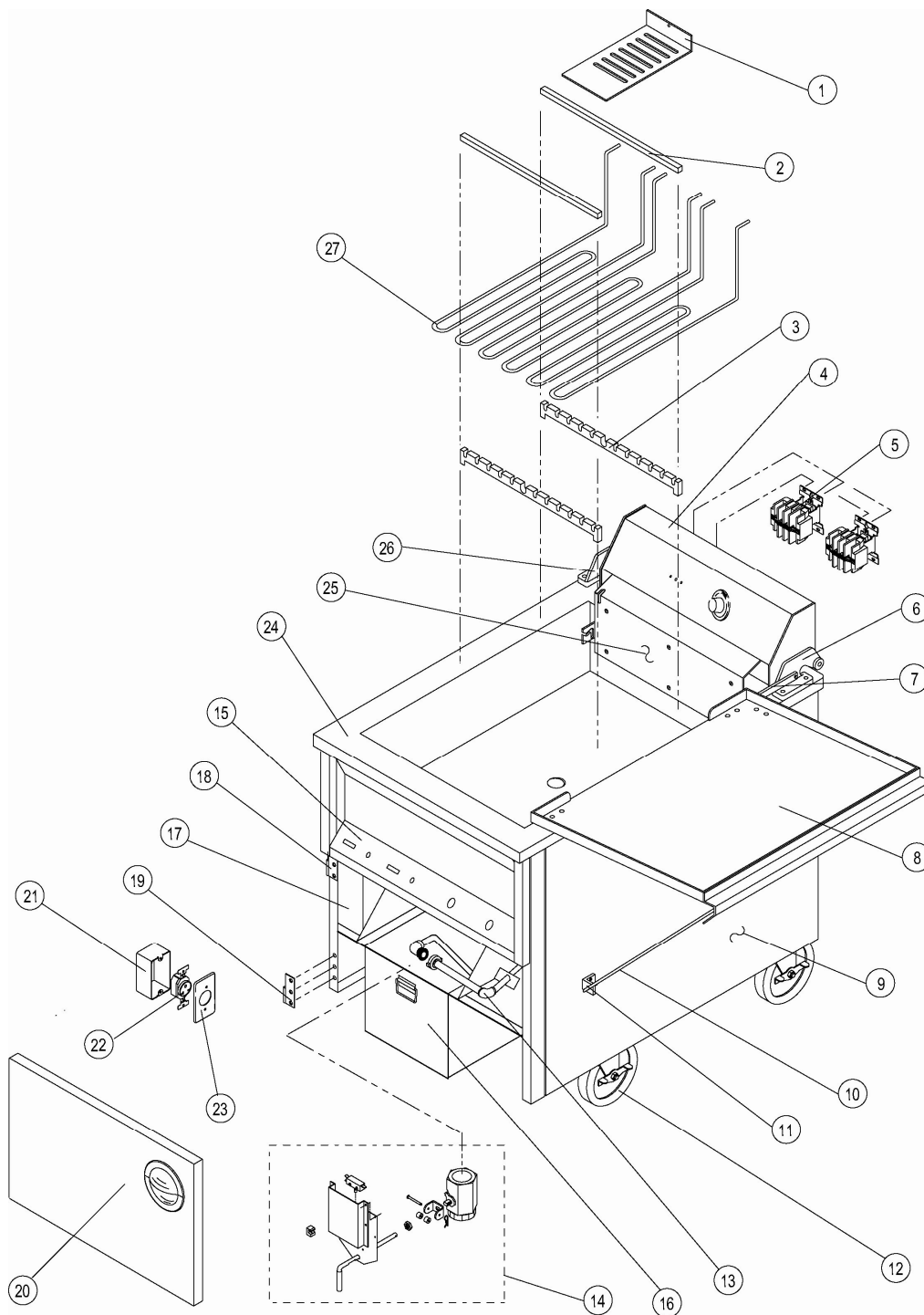

Table 1. DNF/DNF-F Assembly & Components List

PART #	QTY	DESCRIPTION	FIGURE (ITEM #)	TABLE
DNFA023	1	COVER, THERMO BULB	Figure 1 (1)	Table 1
DNFA040	2	BRACKET, CALROD COVER DNF	Figure 1 (2)	Table 1
DNFA065	2	CASTING, CALROD BRKT	Figure 1 (3)	Table 1
SB1817 Or SB7718	1	UPPER CONTROL PANEL 208V DNF, DNFF Or UPPER CONTROL PANEL 240V DNF, DNFF	Figure 1 (4) Figure 2	Table 1 Table 2
R0003	2	RELAY, 4 POLE 240V	Figure 1 (5)	Table 1
DNFA069	1	CASTING, RH HINGE	Figure 1 (6)	Table 1
DNFA024	1	DRAIN, FLIP STOP	Figure 1 (7)	Table 1
SB1834 or SB1804	1	DRAIN BOARD ASSY, LS DNF or DRAIN BOARD ASSY, RS DNF	Figure 1 (8)	Table 1
FKMA399	2	SIDE CABINET, L&R FKM/DNF	Figure 1 (9)	Table 1
DNFA016	1	DRAIN BOARD ROD	Figure 1 (10)	Table 1
DNFA039	2	BRACKET, DRAIN BOARD ANGLE	Figure 1 (11)	Table 1
C0406	4	CASTER, W/TOP PLATE 5"	Figure 1 (12)	Table 1
AN18000100	1	MOTOR & PIPING ASSY DNFF FLEXLINE	Figure 1 (13) Figure 3	Table 1 Table 3
-	1	DRAIN VALVE & HANDLE ASSY	Figure 1 (14) Figure 4	Table 1 Table 4
SB1801 or SB1835	1	LOWER CONTROL PANEL 208V DNF or LOWER CONTROL PANEL 240V DNF	Figure 1 (15) Figure 5	Table 1 Table 5
SB7717	1	COMPLETE OIL VAT ASSY DNF-F	Figure 1 (16) Figure 6	Table 1 Table 6
SB7700 or SB1807	1	FRAME WELD, DNF-F or FRAME WELD, DNF	Figure 1 (17)	Table 1
H0052	1	HINGE, DOOR, LH, NO PIN FRYER DOORS	Figure 1 (18)	Table 1
H0051	1	HINGE, DOOR, RH, NO PIN FRYER DOORS	Figure 1 (19)	Table 1
SB1826	1	DOOR ASSY DNF DNF-FF	Figure 1 (20) Figure 7	Table 1 Table 7
SB1953	1	OUTLET BOX, (DNF ONLY)	Figure 1 (21)	Table 1
RC0015	1	RECEPTACLE, 6-20 SGL HD (DNF ONLY)	Figure 1 (22)	Table 1
C0651	1	COVER, SINGLE RECEPT. (DNF ONLY)	Figure 1 (23)	Table 1
SB1813 or WN18000200	1	VAT WELDMENT, DNF or WELL WELD DNFF	Figure 1 (24)	Table 1
DNFA007	1	SHIELD, CALROD	Figure 1 (25)	Table 1
DNFA068	1	CASTING, LH HINGE	Figure 1 (26)	Table 1
C0024 or C0025	3	CALROD, 208V 2850W or CALROD, 240V 2850W	Figure 1 (27)	Table 1

Figure 2. Upper Control Panel Assembly

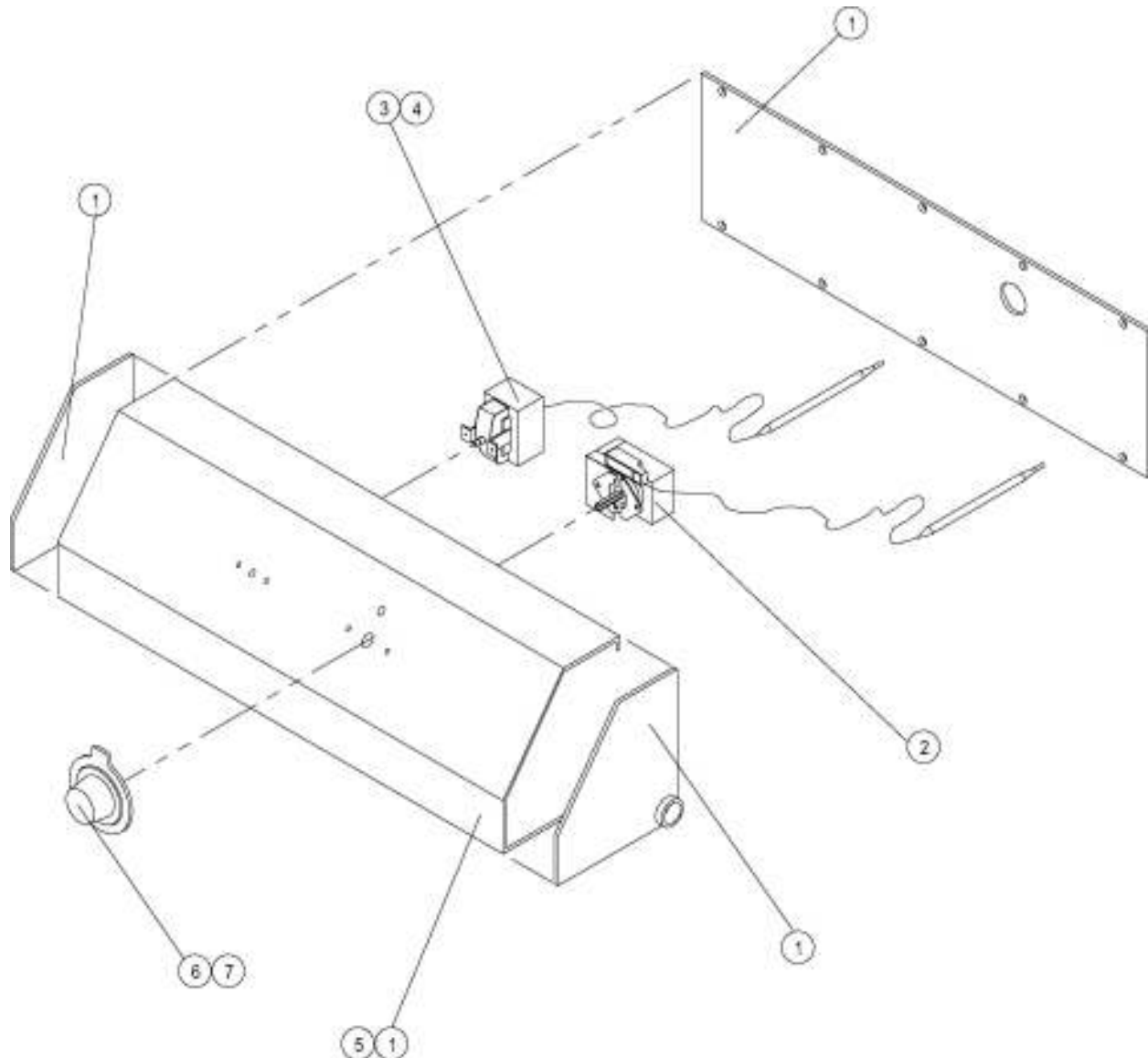

Table 2. Upper Control Panel Assembly Parts

ITEM #	PART #	QTY	DESCRIPTION
1	SB1828	1	UPPER CONTROL PNL & ENDS, DNF
2	T0022	1	THERMOSTAT, 375 DEG SGL POLE
3	T0009	1	THERMOSTAT, HI LIMIT 540 DEG
4	S0073	1	SWITCH, PUSHBUTTON MICRO
5	N0240	1	DECAL, CONTROL PANEL DNF
6	K0030	1	KNOB, T-STAT BLK 400DEG
7	B1050	1	BEZEL, ROBERTSHAW THERMOSTAT
	C0024 * or C0025 *	3	CALROD, 208V 2850W or CALROD, 240V 2850W

* - See Figure 1 (27).

Figure 3. Motor & Piping Assembly

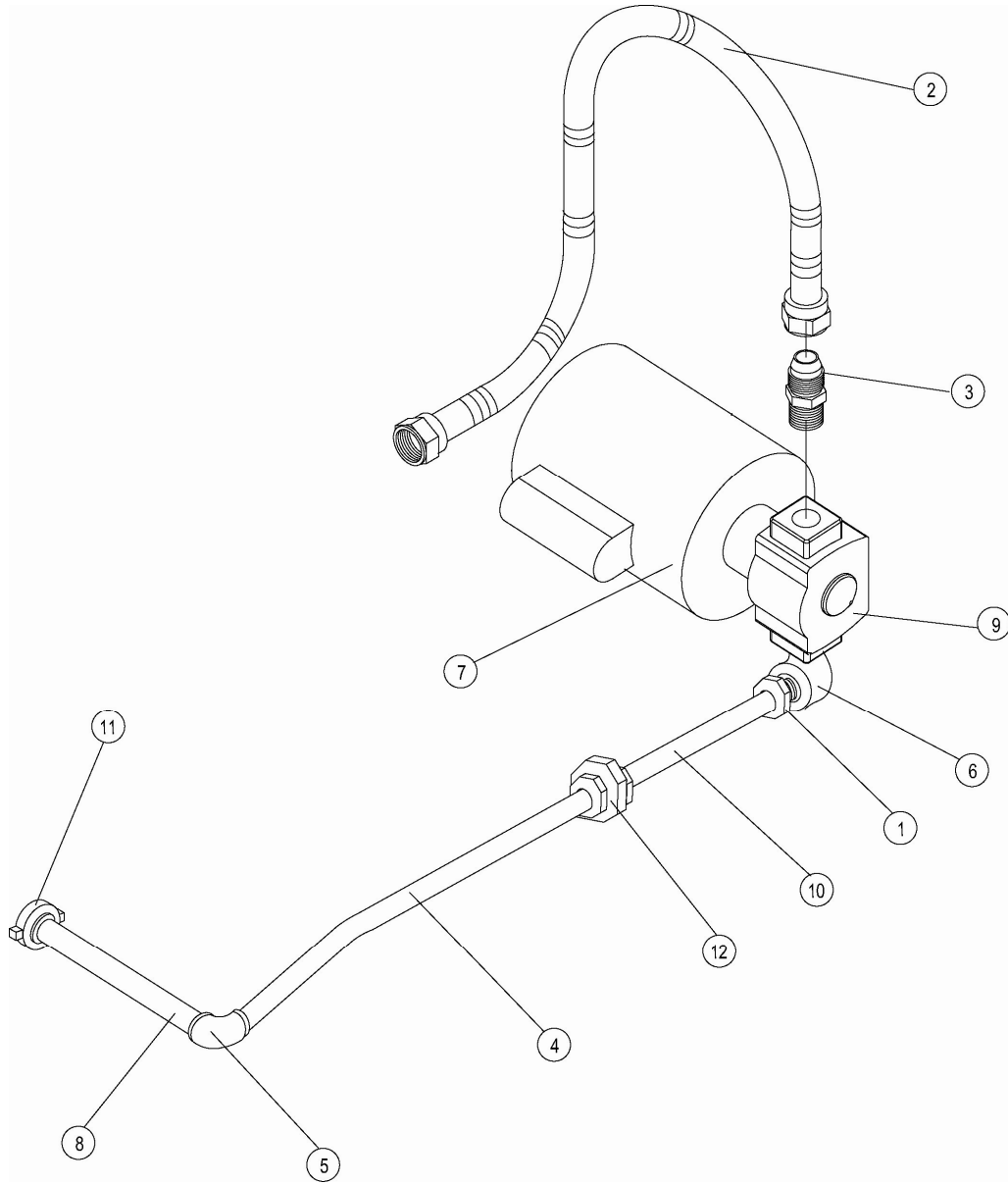

Table 3. Motor & Piping Assembly Parts

ITEM #	PART #	QTY	DESCRIPTION
1	B0851	1	BUSHING, BLK HEX REDUCING
2	LPFFA035	1	CONDUIT, 3/8" FLEX 17"
3	FT0536	1	COUPLING, 5/8 45° FLARE TO
4	DNFFA007	1	DRAIN LINE
5	FT0043	1	ELL, 3/8 90 DEG BLACK
6	FT0132	1	ELL, STREET 1/2 90 DEG BLACK
7	M0053	1	MOTOR, LEESON LESS CORD/PUMP
8	FT0314	1	NIPPLE, 3/8 X 5 BLK PIPE
9	P0070	1	PUMP ONLY FOR HAIGHT MOTOR
10	LPFFA003	1	TUBE 5/8 SS
11	FT0105	1	UNION, 3/8 HANDLE BAR
12	FT0204	1	UNION, 3/8 W/O HANDLE BAR

Figure 4. Drain Valve and Handle Assembly

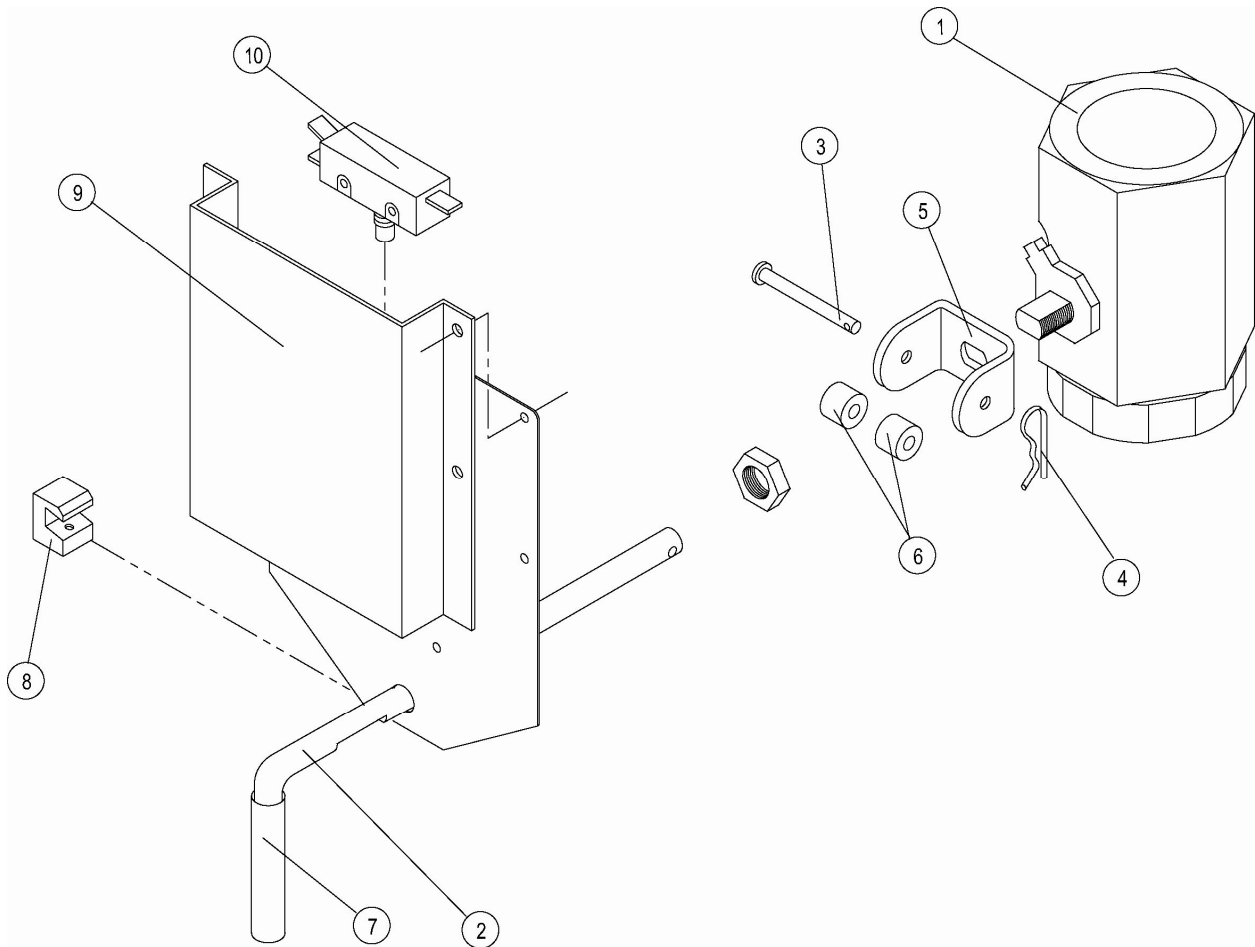

Table 4. Drain Valve and Handle Assembly Parts

ITEM #	PART #	QTY	DESCRIPTION
1	D0060	1	VALVE, DRAIN SS BALL&PLT.CAR.STEM
2	MA18000508	1	HANDLE, DRAIN VALVE DNF
3	F0253	1	PIN, CLEVIS 3/16 X 1 3/4
4	F0254	2	PIN, COTTER HAIRPIN #213
5	FT0543	1	DRAIN VALVE BRACKET, FRYERS
6	SP0034	2	SPACER, DRAIN VALVE BRKT FRYERS
7	C0672	1	COVER, DRAIN HANDLE RED
8	CA0003	1	SWITCH ENGAGING BLOCK
9	DNFFA018	1	MICROSWITCH BOX
10	S0073	1	SWITCH, PUSHBUTTON MICRO

Figure 5. Lower Control Panel Assembly

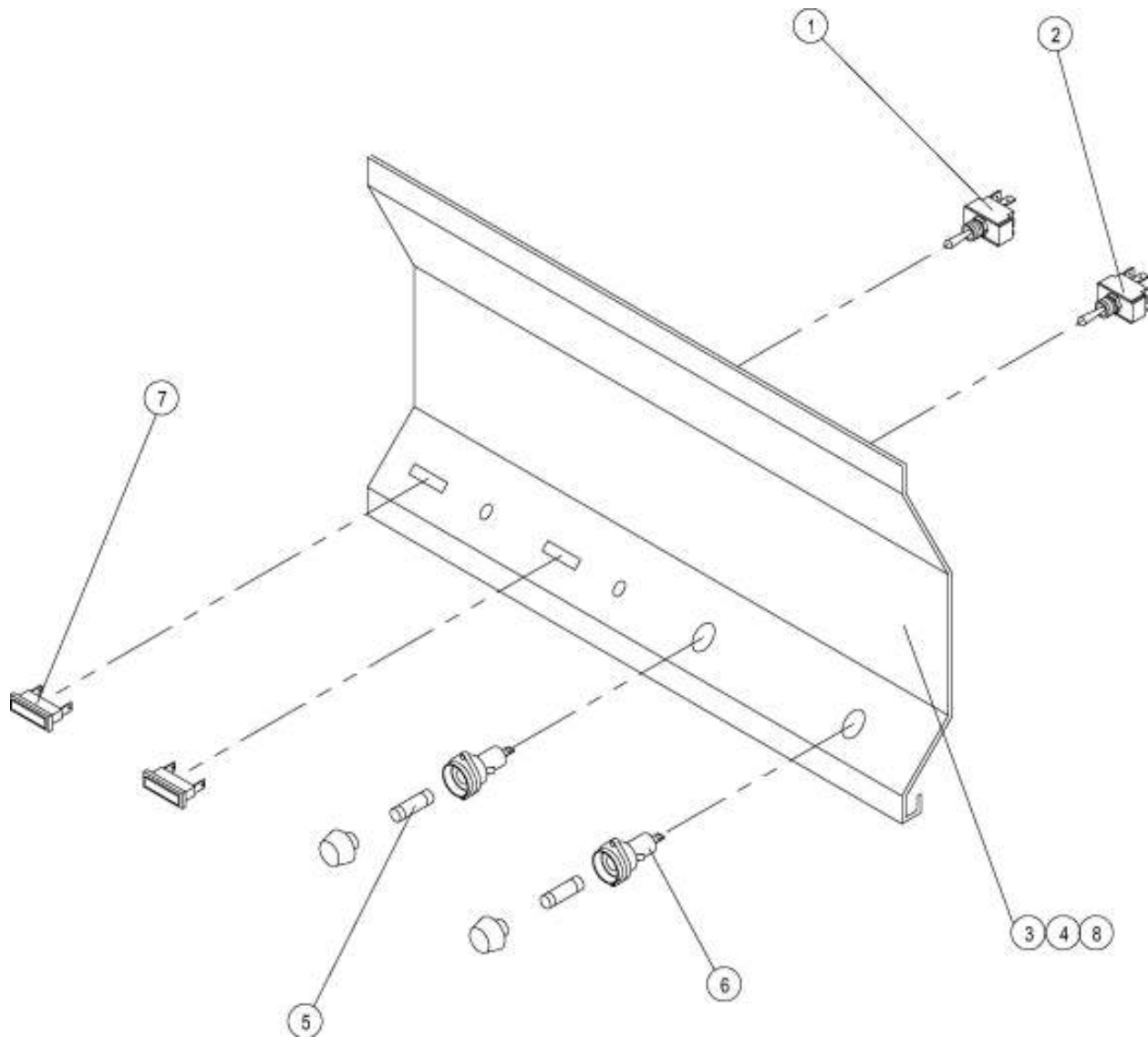

Table 5. Lower Control Panel Assembly Parts

ITEM #	PART #	QTY	DESCRIPTION
1	TS0001 or TS0002	1	SWITCH, TOGGLE SPST (SB1801) or SWITCH, TOGGLE DPST (SB1835)
2	TS0002	1	SWITCH, TOGGLE DPST (SB1801 & SB1835)
3	SB1816	1	LOWER CONTROL PANEL WELD, DNF
4	N0239	1	DECAL, FRONT PANEL DNF (NEW)
5	F0097	2	FUSE, 15A 300V SC15 TIME DELAY
6	FH0001	2	FUSE HOLDER, 15A 300V HPF-EE
7	PL0003	2	PILOT LIGHT, 250V RECT BLK BEZEL
8	N0412	1	DECAL, UPPER FRONT PANEL DNF

Figure 6. Complete Oil Vat Assembly

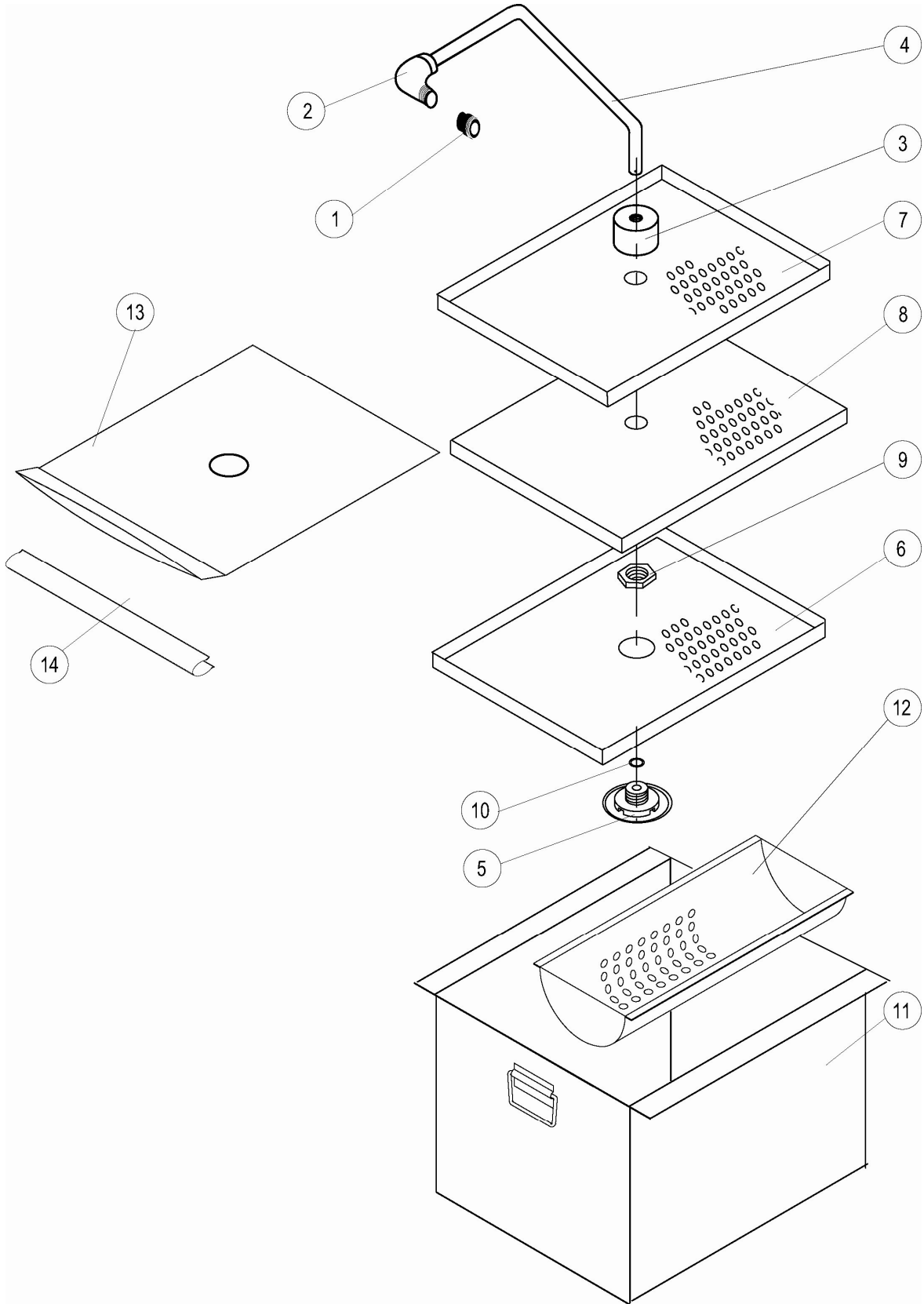

Table 6. Complete Oil Vat Assembly Parts

ITEM #	PART #	QTY	DESCRIPTION
	SB7716	1	FILTER SCREEN ASSY DNFF
1	FT0105	1	UNION, 3/8 HANDLE BAR
2	FT0044	1	ELL, STREET 3/8 90 DEG BLACK
	SB7715	1	TUBE WELD ASSY, DNF-F
3	FC0003	1	FEMALE COUPLING
4	DNFFA028	1	TUBING, SCREEN TO UNION DNFF
5	SB7659	1	FILTER SCREEN FITTING SPOTWELD
6	FS0001	1	FILTER SCREEN, BOTTOM
7	FS0002	1	FILTER SCREEN, INTERCEPTOR
8	FS0003	1	FILTER SCREEN, TOP
9	FC0004	1	NUT SCREEN RETAINING FKM-F &
10	O0013	1	O-RING, FLUOROCARBON V680-70
11	SB2307	1	OIL CONTAINER WELD, FKF
12	SB2306	1	S/S CRUMB BASKET WELD, FKF
13	FI0007	1	FILTER, FKM-F 13.5 X 20.5
14	ST0015	1	FILTER BAG CLIP FKM-F

Figure 7. Door Assembly

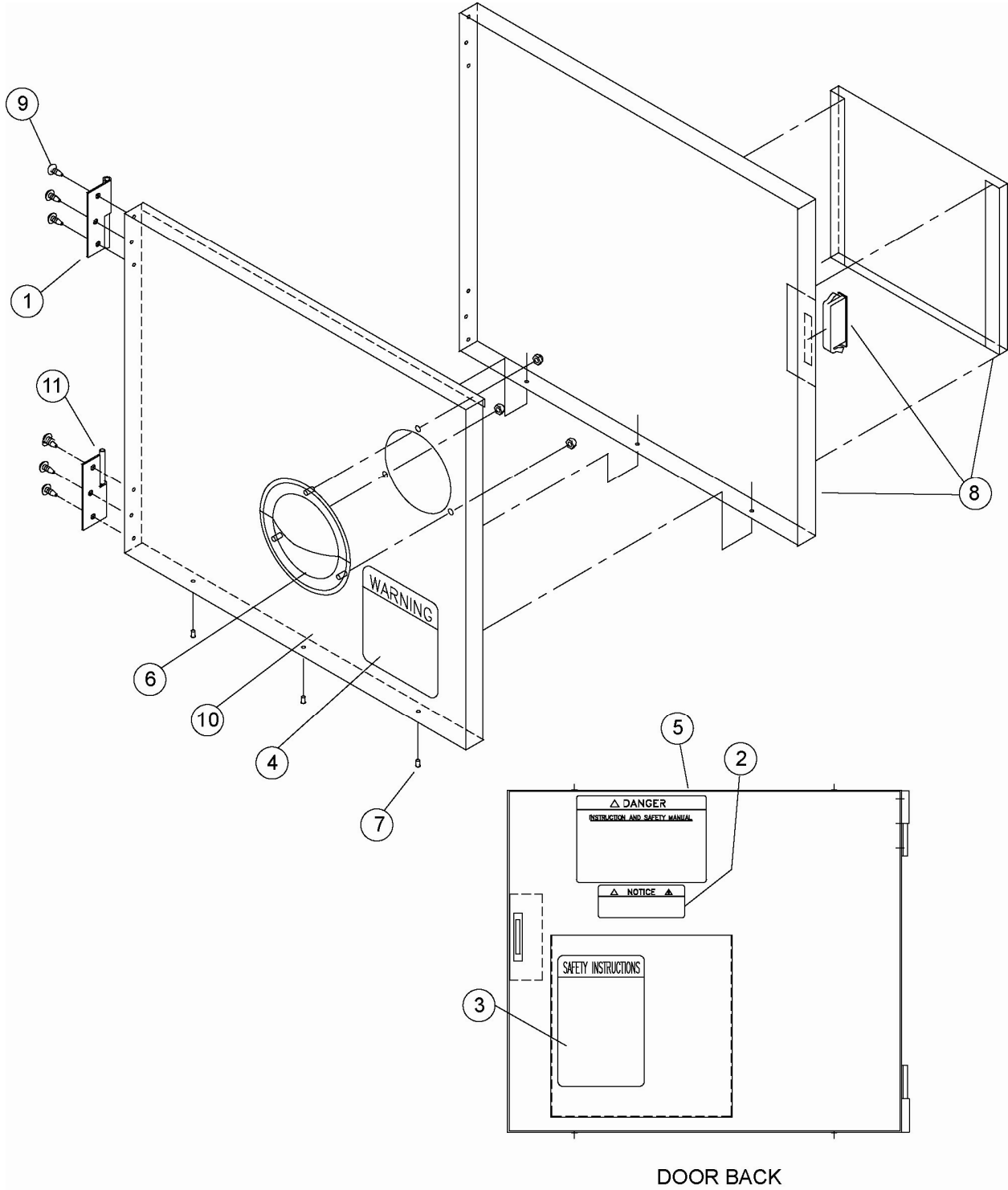



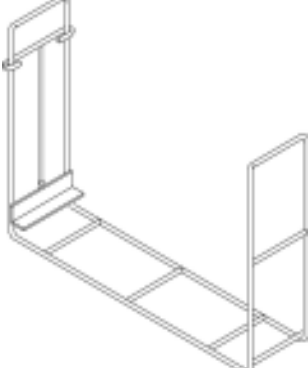



Table 7. Door Assembly Parts

ITEM #	PART #	QTY	DESCRIPTION
1	H0010	1	HINGE, LH PIN HALF
2	N0165	1	DECAL, NOTICE LOST MANUAL
3	N0527	1	DECAL, SAFETY INSTR FRYERS
4	N0175	1	DECAL, SLIPPING ADMONITIONS
5	N0176	1	DECAL, INSTR & SAFETY MANUAL
6	P0022	1	HANDLE, PULL SS P60-1010
7	RIV172	3	RIVET, 1/8 X 1/4 CS PLT POP
8	SB1951	1	INSIDE DOOR POCKET/MAGNET WELD FKM
9	SCR008	6	SCREW, 10 X 1/2 PHIL TRUSS HD
10	WFKMA178	1	DOOR, FRYER OUTSIDE WELD
11	H0009	1	HINGE, DOOR, RH, PIN SIDE FRY.DOORS

Accessories

Accessory #	Description	Picture
D0012	DOWELL, WOODEN 1/2X18"	
R0012	RACK, FRY SCREEN 17" X 25"	
R0019	RACK, 17 X 25 SUBMERSION SCREEN	
R0020	RACK, FRY SCREEN LIFTER	
G0052	INSULATED MITT 13"	

Wiring Diagrams

Refer to the table below to find the wiring diagram associated with your unit.

Description	Wiring Diagram #	Figure #	Page #
DNF/DNF-F 220V/380V/50 Hertz/3 Phase	DNFE1015	Figure 8	22
DNF/DNF-F 240V/415V/1 Phase or 220V/380V/1 Phase or 200V/346V/1 Phase	DNFE1016	Figure 9	23
DNF/DNF-F 240V/1 Phase	DNFE1014	Figure 10	24

Figure 8. DNF/DNF-F 220V/380V/50 Hertz/3 Phase

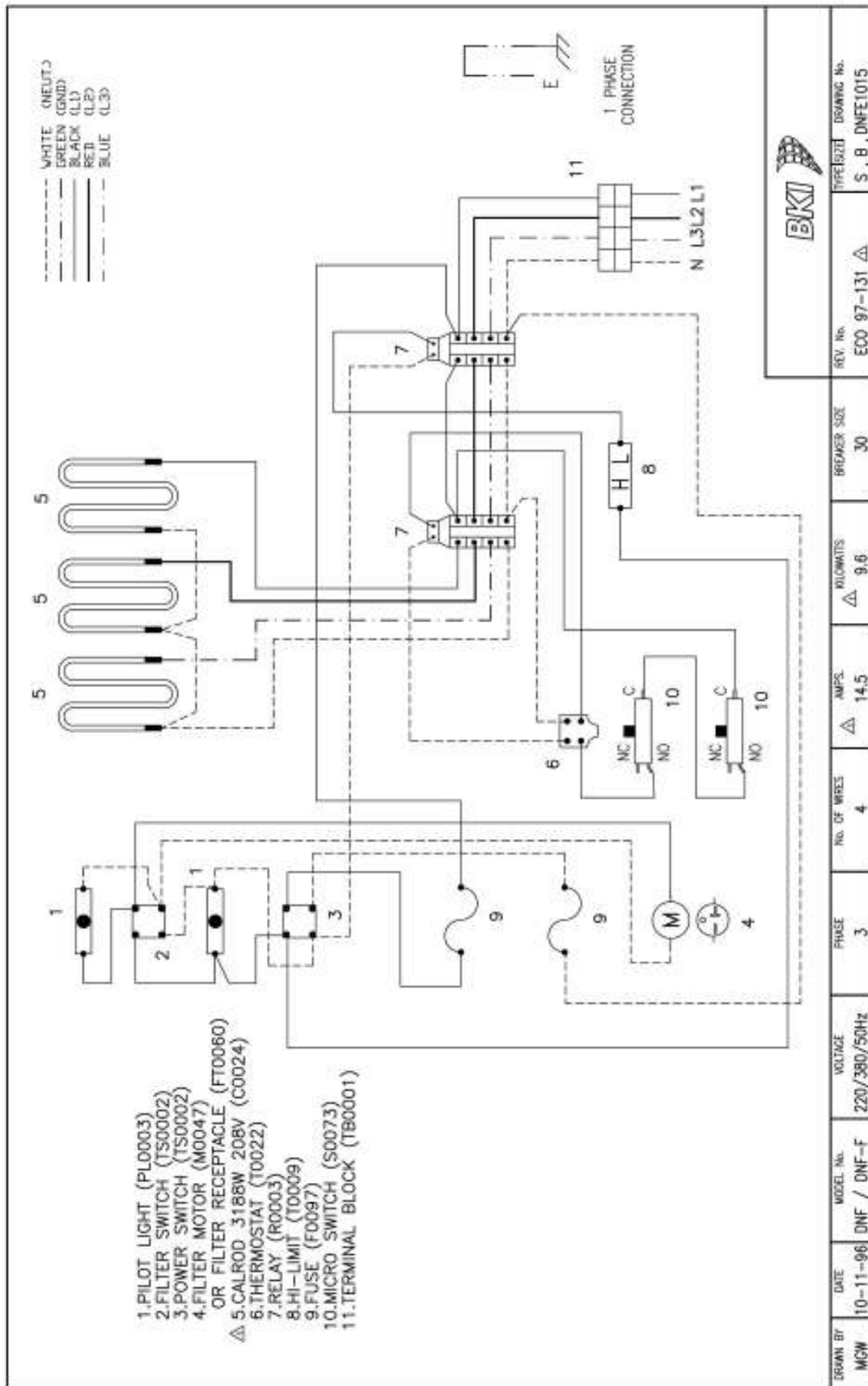

Figure 9. DNF/DNF-F 240V/415V/1 Phase or 220V/380V/1 Phase or 200V/346V/1 Phase

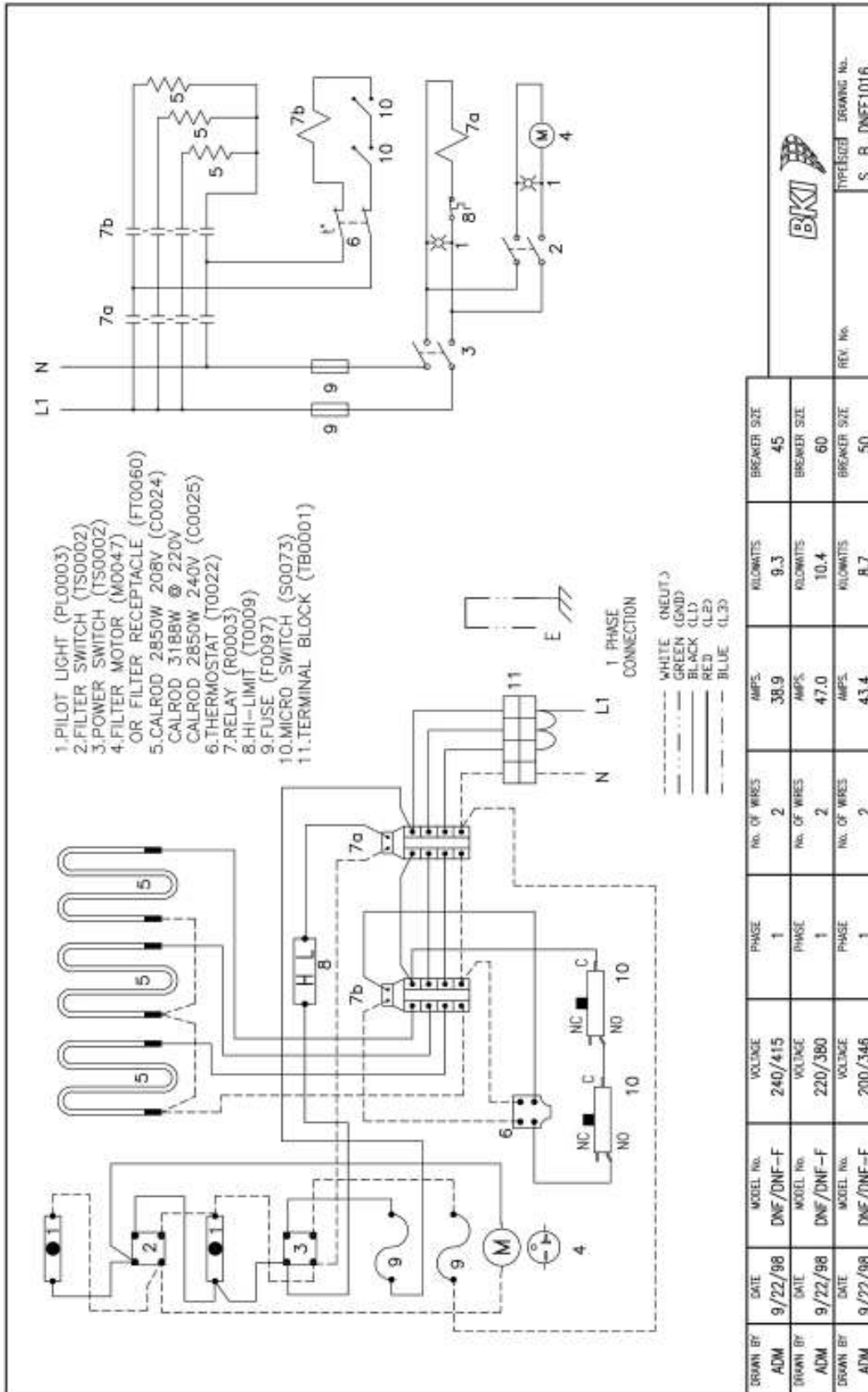
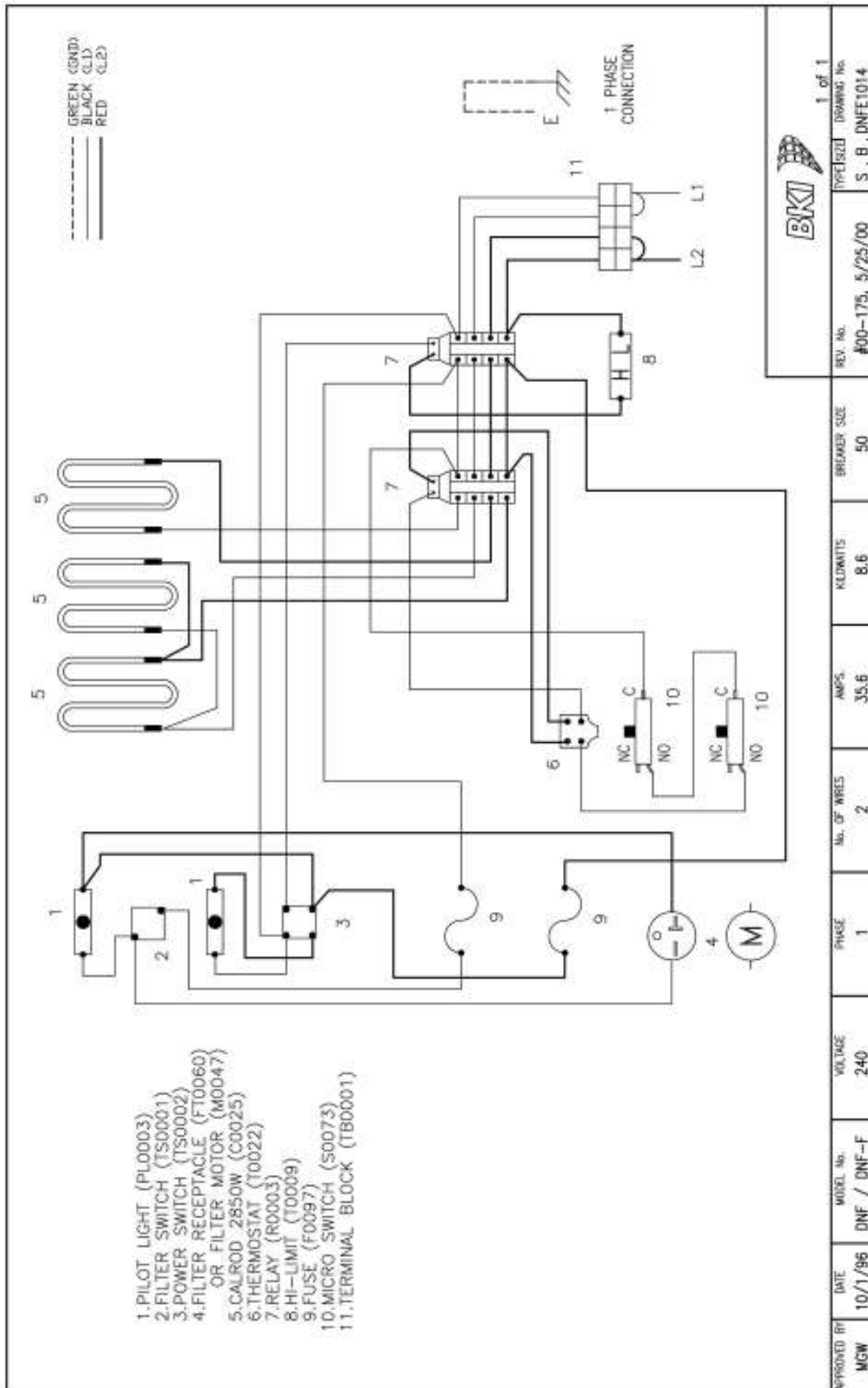

Figure 10. DNF/DNF-F 240V/1 Phase



Notes



2812 Grandview Dr., Simpsonville, S.C. 29680, USA
<http://www.bkideas.com>

Made and printed in the U.S.A
LI0257/0407

CS-TM-020.01

Revised 03/22/13

REVISION HISTORY

<u>REVISION</u>	<u>DATE</u>	<u>REVISED BY</u>	<u>DESCRIPTION</u>
01	03/22/13	KW	Initial Release-Supersedes all previous releases