

BIRO® SIR STEAK

MODEL XHD HEAVY DUTY TENDERIZER

Parts List, Installation and Operating Instructions

**Serial Number 55405 on
with Magnetic Contactor and
Safety Cover Magnetic Interlock Switch**

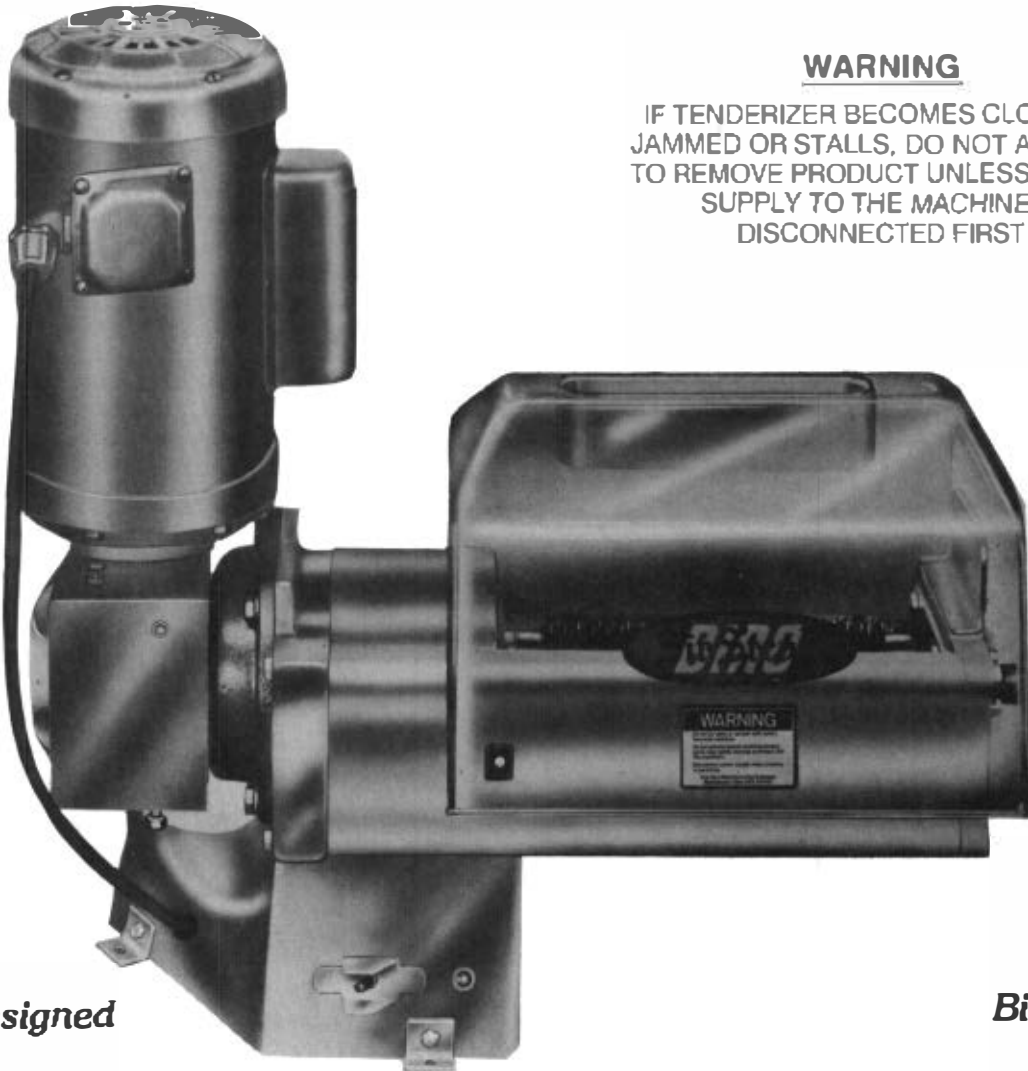

WARNING

**IF TENDERIZER BECOMES CLOGGED,
JAMMED OR STALLS, DO NOT ATTEMPT
TO REMOVE PRODUCT UNLESS POWER
SUPPLY TO THE MACHINE IS
DISCONNECTED FIRST**

Biro Designed

Biro Built



IMPORTANT NOTICE



**This Manual contains important
safety instructions which must
be strictly followed when using
this equipment.**

SAFETY TIPS



SHARP ROTATING BLADES TO AVOID SERIOUS PERSONAL INJURY

- **NEVER** Touch This Machine without Training and Authorization by Your Supervisor.
- **ALWAYS** Keep Hands Clear of Blades and Moving Parts.
- **ONLY** Use a Qualified Electrician to Install According to Local Building Codes: Machine **MUST** Be Properly Grounded.
- **ALWAYS** Connect to Proper Voltage & Phase.
- **ONLY** Install on Level, Non-Skid Surface in a Clean, Well-lit Work Area Away from Children and Visitors.
- **DO NOT** Tamper With, Bypass or Remove the Safety Cover, Interlock Switch, or Toggle Switch.
- **DO NOT** Operate With the Safety Cover in Raised Position or Removed. Safety Cover **MUST** Be Down During Operation.
- **ONLY** Operate Machine by Using the Machine's ON/OFF Toggle Switch. **ALWAYS** Turn Off Toggle Switch When Not in Use.
- **DO NOT** Wear Gloves While Operating.
- **ALWAYS** Turn Off, Unplug Machine From Power Source and Perform Lockout/Tagout Procedure to this machine **BEFORE** Attempting to Unjam or Unclog, Cleaning or Servicing
- **ALWAYS** Wear Wire Mesh Safety Gloves When Touching or Handling Stew Cutter or Stripper Attachments.
- **NEVER** Leave Machine Unattended While Operating.
- **NEVER** Alter This Machine From its Original Form as Shipped From Factory. **DO NOT** Operate Machine With Missing Parts.
- **PROMPTLY REPLACE** Any Worn or Illegible Warning Labels.
- **ALWAYS** Read Operation and Service Manual **BEFORE** Operating, Cleaning, or Servicing.
- **USE ONLY BIRO** Parts and Accessories Properly Installed.

INSTALLATION



TO AVOID SERIOUS PERSONAL INJURY, PROPERLY INSTALL EQUIPMENT IN ADEQUATE WORK AREA

- **ALWAYS** Use Qualified Technician and Electrician for Installation.
 - **ALWAYS** Connect to Proper Voltage & Phase.
 - **ALWAYS** Install Equipment in Work Area with Adequate Light and Space Away From Children and Visitors.
 - **ONLY** Operate on a Solid, Level, Non-Skid Surface.
 - **NEVER** Bypass, Alter, or Modify This Equipment in Any Way From Its Original Condition.
 - **NEVER** Operate With Safety Cover in raised Position or Removed.
 - **NEVER** Operate Without all Warning Labels Attached and Owner/Operator Manual Available to the Operator.
1. Read this Manual thoroughly before installation and operation. Do not proceed with installation and operation if you have any questions or do not understand anything in this Manual. Contact your local Distributor, or BIRO first.
 2. Install machine on a level, solid, non-skid surface in a well-lighted work area away from children and visitors. Brackets are attached to machine for bolting onto work table.
 3. Machine must be properly grounded. Use a qualified electrician to install according to building codes.
 4. Make sure ON/OFF toggle switch is in "OFF" position.
 5. Lower Safety Cover into operating position as shown in the picture on the front of this Manual.
 6. Uncoil electrical cord and plug into specified, grounded outlet. (Specifications for this machine are found on the plate located on the back of main body.)
 7. With Safety Cover lowered in the operating position, turn ON/OFF toggle switch to "ON" position. Push toggle switch to "START" position. The blades will begin to rotate. The toggle switch will return to the "ON" position. Make sure machine operates properly and is stable and secure on operating surface.



KEEP HANDS CLEAR OF SHARP ROTATING BLADES.

8. Raise Safety Cover to check safety interlock switch — machine will turn off.
9. Lower Safety Cover — machine will not resume operating, the toggle switch must be moved to "START" position to resume operation.
10. Turn toggle switch to "OFF" position.
11. Check placement of all warning labels. Machine is ready for trained operators to process product.
12. Contact your local distributor or BIRO directly if you have any questions or problems with the installation or operation of the machine.

CLEANING



SHARP ROTATING BLADES TO AVOID SERIOUS PERSONAL INJURY

- **ALWAYS** Turn Off, Unplug From Power Source and Perform Lockout/Tagout Procedures to This Machine Before Cleaning or Servicing.
- **ALWAYS** Wear Wire Mesh Safety Gloves When Touching or Handling Stew Cutter or Stripper Attachments for Removal and Cleaning Purposes Only.
- **ONLY** Use Recommended Cleaning Equipment, Materials, and Procedures.
- **NEVER** Spray Water or Other Liquid Substances Directly at Motor, Power Switch or any Other Electrical Components.
- **ALWAYS** Thoroughly Clean Equipment at Least Daily.

A. CLEANING SAFETY COVER

1. **BEFORE** cleaning, turn toggle ON/OFF switch to "OFF" position and **UNPLUG** machine from power supply and perform lockout/tagout procedures.
2. Raise Safety Cover. Wash Safety Cover with soapy water of 120°-130°F and wipe with non-abrasive cloth.
3. Rinse thoroughly with hot water and allow to air dry.
4. Check to make sure all labels are intact and legible. Replace labels if they are worn or illegible.

B. CLEANING CRADLE AND BLADE ASSEMBLIES



ALWAYS WEAR WIRE MESH SAFETY GLOVES WHEN TOUCHING OR HANDLING STEW CUTTER OR STRIPPER ATTACHMENTS.

1. Remove front wire comb (Item No. X5116A) by raising it by both ends and rolling it out in a forward motion. Remove rear wire comb (Item No. X5117A) by raising it by both ends and rolling in out in a rearward motion.
2. Remove cradle assembly as follows:
 - a. Loosen the two end piece screw nuts (Item No.'s X5006-3) on right side of tenderizer frame. Grasp the end piece block at the end piece finger guard (Item No. X5006-9) and lift straight up and remove.
 - b. Grasp tenderizer knife shafts by the nylon end bearings (Item No. X5033-2) and pull away from transmission drive couplings.
 - c. Lift cradle assembly (Item No. XA5130Z) out of the machine frame.
3. Next, remove the front and rear Blade Assemblies (Item No.'s XA5131Z & XA5132Z). Holding the shaft end bearing of the front blade assembly in your left hand and the shaft end bearing of the back blade assembly in your right hand. Pivot both blade assemblies away from each other and slide the knife shaft coupling ends out of their pilot holes.

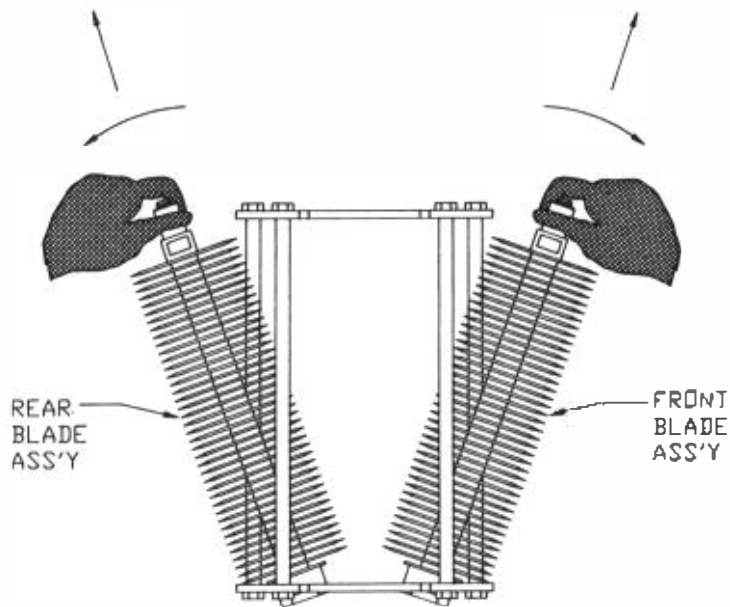

4. With the parts disassembled, they should be cleaned and sanitized as follows:

STEP 1

Rinse Cradle Assembly, wire combs, and Blade Assemblies in a water bath of 110°-115°F to loosen particles.

STEP 2

Immerse all items in soapy bath of 120°-130°F and clean using the BIRO Cleaning Brush, Part #T3091-1

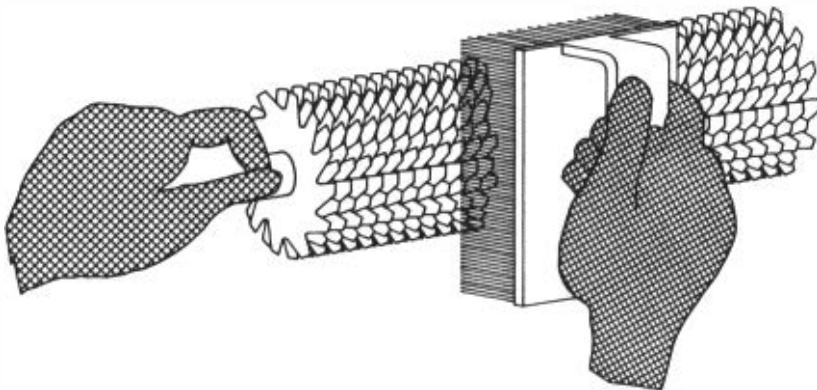

CLEANING TENDERIZER, SCORING, CUTLET AND STAR BLADE ASSEMBLIES



ALWAYS WEAR WIRE MESH SAFETY GLOVES WHEN TOUCHING OR HANDLING STEW/STRIP CUTTER BLADE ASSEMBLIES.

MAINTENANCE



SHARP ROTATING BLADES TO AVOID SERIOUS PERSONAL INJURY

- **ALWAYS** Turn Off, Unplug from Power Source and Perform Lockout/Tagout Procedures to This Machine **BEFORE** Servicing.
- **NEVER** Touch This Machine Without Training and Authorization By Your Supervisor
- **ALWAYS** Keep Hands Clear of Blades and Moving Parts.
- **DO NOT** Tamper With, Bypass, or Remove the Safety Cover, Interlock Switch, or Toggle Switch.
- **ALWAYS** Wear Wire Mesh Safety Gloves When Touching or Handling Stew Cutter or Stripper Attachments for Removal and Cleaning Purposes Only.
- **PROMPTLY REPLACE** Any Worn or Illegible Warning Labels.
- **USE ONLY GENUINE BIRO** Parts and Accessories Properly Installed.

A. GENERAL

1. Machine should be generally inspected every time it is cleaned (daily) to ensure that it is in good operating condition and has not been damaged or tampered with.
 - a. **SAFETY COVER:** The Safety Cover should be checked for cracks, gouges, or other damage. Replace if any of these conditions exist.
 - b. **SWITCHES and SAFETY INTERLOCK:** All switches should be checked for proper operation. Check the rubber cap nut on the toggle switch (Item No. X5287-6) for wear, tears, or damage. Replace if worn, torn, or damaged. Check that the interlock switch activating magnet (Item No. X5200M-2) is securely fastened to the Safety Cover.

The Safety Cover interlock switch should be checked as follows:

- i. Make sure ON/OFF toggle switch is in "OFF" position.
- ii. Lower Safety Cover into operating position.
- iii. Plug electrical cord into specified outlet.
- iv. With Safety Cover lowered into operating position, turn ON/OFF toggle switch to "ON" position. Push toggle switch to "START" position. The blades will start rotating. The toggle switch will return to the "ON" position.



KEEP HANDS CLEAR OF SHARP ROTATING BLADES.

- v. Raise Safety Cover to check safety interlock switch operation — machine should turn off.
- vi. Lower Safety Cover — machine will not resume operating. The toggle switch must be moved to the "START" position to restart operation.
- vii. Turn toggle switch to "OFF" position. Unplug machine from power source and perform lockout/tagout procedures.



DO NOT USE THIS MACHINE IF ANY SWITCH FAILS TO FUNCTION PROPERLY.



TURN OFF AND UNPLUG MACHINE FROM POWER SOURCE AND PERFORM LOCKOUT/TAGOUT PROCEDURES BEFORE PERFORMING ANY OTHER MAINTENANCE.

- c. **CRADLE and BLADE ASSEMBLIES:** The blades and teeth of the Blade Assemblies should be checked for any damage, including broken, bent, or missing teeth, or gouged or bent teeth. Any damaged Blade Assemblies should be replaced.
- d. **MACHINE FRAME:** The machine frame should be checked for damage beyond ordinary wear and tear. The electrical cord should be checked for gouges, fraying, or other damage. Damaged cords should be replaced.
- e. **LABELS:** The labels on the machine should be replaced if they are worn, torn, or illegible.

B. LUBRICATION

1. The oil in both Gear Boxes must be changed after the first three (3) months of operation and, thereafter every three (3) to six (6) months, depending on the number of hours used (8 to 10 hours daily).

TO CHANGE OIL IN DOUBLE SHAFT ALUMINUM GEAR BOX UNIT (Item No. XA5002-20):

- a. Remove vented plug (Item No. X5002-4) from top of gear box.
- b. Remove gear box oil drain cap (Item No. X5002-6) located on rear of gear box. When oil is finished draining replace this cap.
- c. Fill gear box with four ounces (4 oz.) only of either #140 EP or Mobil 600W cylinder oil or equivalent.
- d. Replace vented plug.

TO CHANGE OIL IN GRANT GEAR REDUCER

- a. Remove filler plug from top of gear reducer. Remove fill level plug from side of gear reducer.
- b. Remove drain plug from under gear reducer. When finished draining, replace drain plug.
- c. Refill to level of side level plug with Mobile Extra Hecla Super Cylinder Oil.
- d. Replace fill level plug and filler plug.

ASSEMBLY OF XHD CRADLES:

NOTE: BIRO RECOMMENDS THE USE OF WIRE SAFETY GLOVES WHEN HANDLING THE BIRO XHD TENDERIZER'S CUTTING GROUPS.

STEP 1: Place the empty stew cradle on table top with right hand cradle end away from you, left hand cradle end toward you

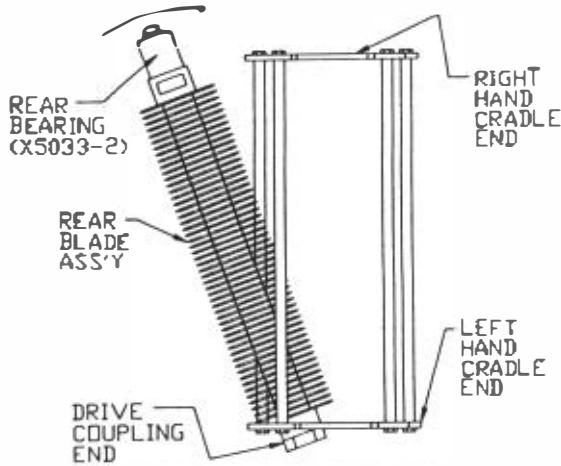

STEP 2:

Holding Delrin bearing end, insert back blade assembly coupling into rear coupling hole on left hand cradle end. Pivot shaft into right hand cradle end slot.

STEP 3:

Holding Delrin bearing end, insert front blade assembly coupling slightly into hole on left cradle end. **CAUTION: DO NOT FORCE OR MAKE CONTACT WITH REAR ASSEMBLY OR BOTTOM OF CRADLE BAR OR BLADES WILL BE CHIPPED.**

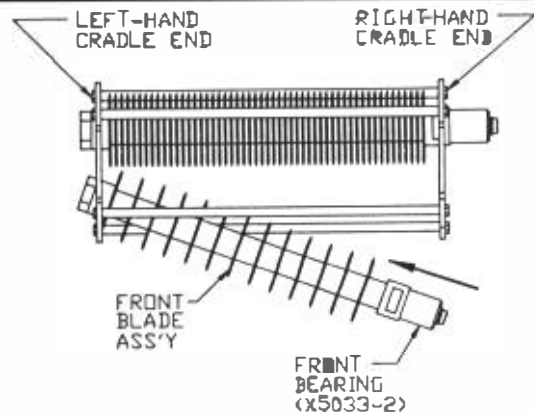

STEP 4:

Holding the Delrin bearing end of the front blade assembly in your right hand, clutch the Delrin bearing end of the back blade assembly with your left hand and pivot the rear feeder blades away from the front knife blades.

STEP 5:

GENTLY pivot both blade assemblies together **SIMULTANEOUSLY**. Make sure the knife blade at the left hand cradle end is between the first indicated spacer of the feeder blade assembly at the same end. Upon meshing both blade assemblies correctly allow both Delrin bearing ends to rest in the cradle supports.

NOTE: You must take extra care in this procedure so as to match the back feeder blade assembly equally to the front cutting rollers in the exact way it came from the factory. If assembled properly, no binding should occur between the front and rear blade groups.

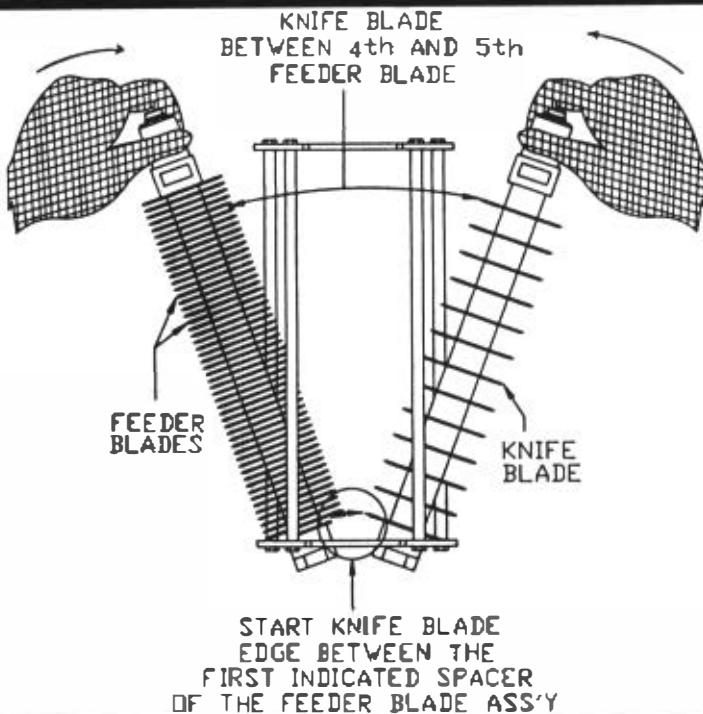

ASSEMBLY OF XHD CRADLES (Cont.)

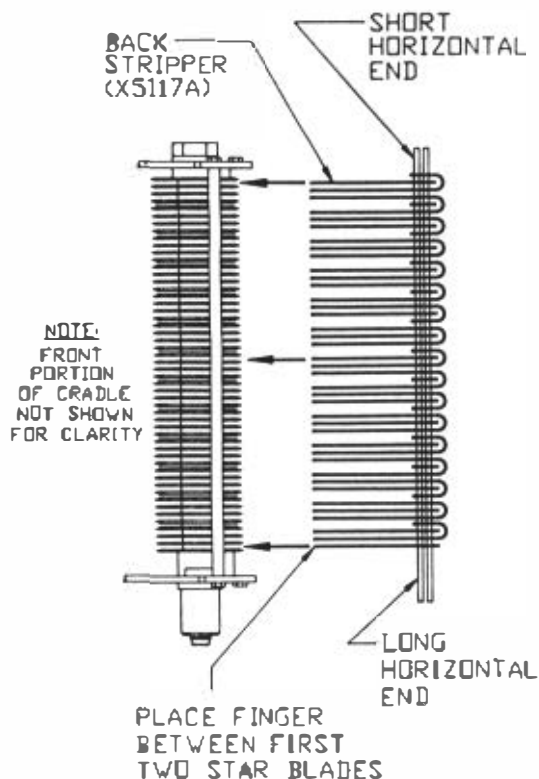

STEP 6:

Turn cradle assembly so that the right hand cradle end in toward you, left hand cradle end away. Place back stripper X5117A in right hand with the short horizontal end away from you. Place the finger closest to you (finger closest to right hand cradle end) between the first two feeder blades on the back blade assembly

CAUTION: IF STRIPPER FINGERS ARE BENT OR DISTORTED, RESTRAIGHTEN SUSPECT STRIPPER FINGER BACK INTO CORRECT POSITION USING THE STRIPPER STRAIGHTENER TOOL — PART No. T3119.

PLACE KNIFE BLADE BETWEEN FIRST TWO FINGERS

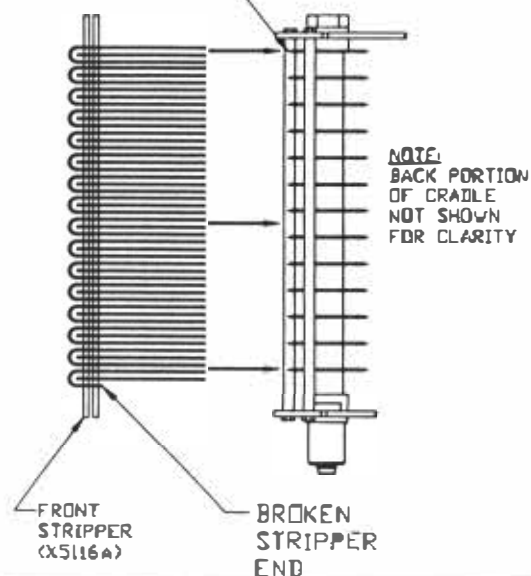

STEP 7:

Place front stripper X5116A in left hand with fractured stripper end toward you. Place the first knife blade (knife blade closest to right hand cradle end) between the second and third fingers on the front stripper.

STEP 8:

Holding the cutting group's support bars, begin to install the assembled cutting group into XHD Tenderizer. Open hopper cover, then install cutting group by inserting coupling ends first and then rotating the right hand Delrin bearings counter-clockwise onto the cutting group supports. Make sure coupling ends are locked into the driving shafts and then attach end locking plate to firmly secure the cutting group. Close hopper cover and begin operation.

Electrical Components Starting with S/N 55405

Item Number	Description
BCC24	Power cord & plug, 115V, 1PH
BCC24-1	Power cord & plug, 220V, 1PH
BCC24-1A	Power cord & plug, 220V, 3PH
X5096M	Aluminum safety cover w/magnet
X5096M-1	Transparent safety cover w/magnet
X5200M	Reed safety switch
X5200M-2	Safety switch magnet
X5282M	Transformer, 220V to 110V
X5283M	Transformer fuse, FNM 3/10
X5284M	Transformer hold down screw
X5284M-6	Transformer hold down flatwasher
X5284M-8	Transformer hold down lockwasher
X5285M-1	Contactor, AEG, 110V
X5286M	Contactor hold down screw
X5287M	Toggle switch, 110V, momentary start
X5287-7	Pilot light, 110V

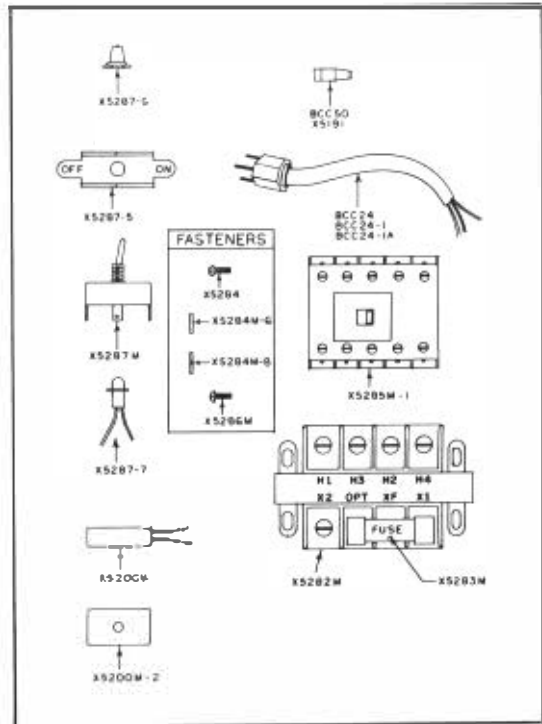

XHD Gear Reducer On and After Serial No. 35940 XA5245 Complete Transmission

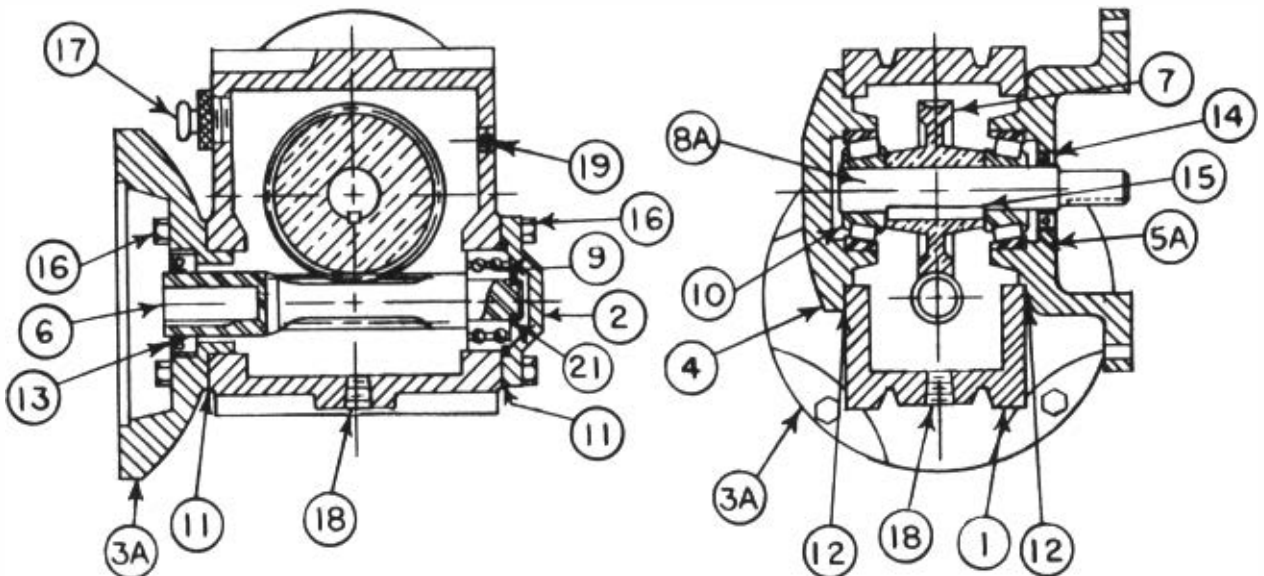

Key	Item Number	Description
0	XA5245	Grant gear reducer, complete
1	X5245-1	Housing
2	X5245-2	Worm gland closed
3A	X5245-3A	Motor flange
4	X5245-4	Worm gear gland closed
5A	X5245-5A	Worm gear gland open
6	X5245-6	Worm and shaft integral
7	X5245-7	Worm gear
8A	X5245-8A	Worm gear shaft
9	X5245-9	Worm ball bearing, hi speed
10	X5245-10	(2) Worm gear bearings, lo speed

Key	Item Number	Description
11	X5245-11	Motor flange gasket
12	X5245-12	Gear gland gasket
13	X5245-13	Motor flange oil seal, hi speed
14	X5245-14	Worm gear gland oil seal, lo speed
15	X5245-15	Worm gear key
16	X5245-16	Worm gland flange cap screw
17	X5245-17	Breather plug
18	X5245-18	Oil level pipe plug
19	X5245-19	Oil drain pipe plug
21	X5245-21	Worm snap ring

XHD Main Frame, Base and Motor Parts List

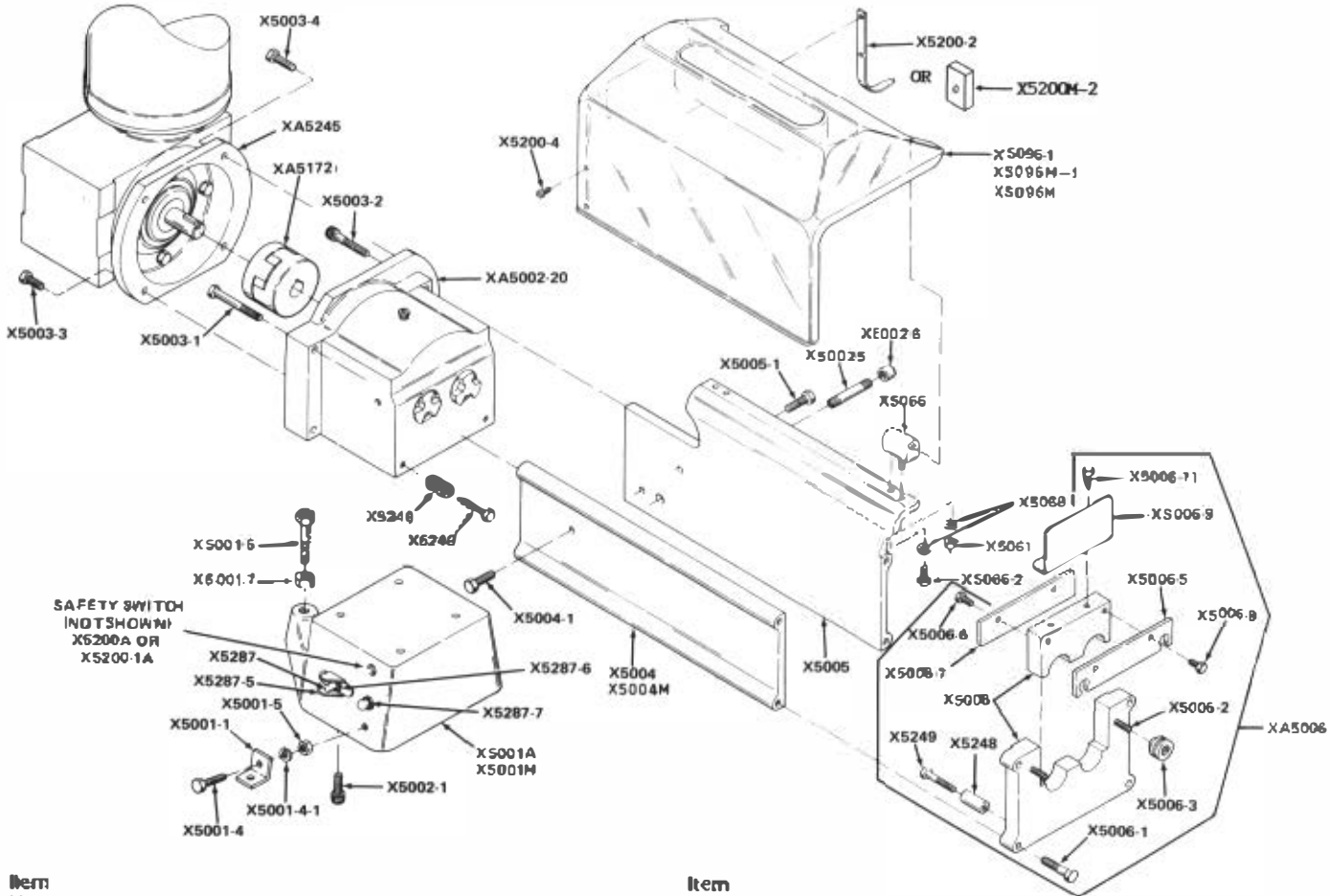

Item Number	Description	Item Number	Description
X5001-1	Front foot on base	X5006-7	End thrust plate
X5001-4	Foot screw on base	X5006-8	End locking plate screw
X5001-4-1	Base foot screw lockwasher	X5006-9	End finger guard
X5001-5	Base foot screw nut	X5006-11	End piece finger guard screw
X5001-6	Base support screw	(***)	Motor — Specify electrical characteristics (See X5045.)
X5001-7	Base support screw nut	X5066	Hopper hinge
X5001A	Base, #51195 to #55404	X5066-2	Hopper hinge screw
X5001M	Base, #55405 on	X5008	Hopper hinge screw lock washer
X5002-1	Gear box base screw	X5096-1	Transparent hopper with interlock switch activator, up to #55404
X5002-2	Gear box bracket screw long	X5096M	Aluminum safety cover w/magnet, #55405 on
X5002-5	Gear box oil drain tube	X5096M-1	Transparent safety cover w/magnet, #55405 on
X5002-6	Gear box oil drain cap	XA5172	Reducer unit steel coupling, complete #39966 on
XA5002-20	Gear box complete with gears #51495 on	X5200-1A	Safety switch, 3 phase 220 volt & 1 phase 220 volt, up to #55404
X5003-1	Gear box bracket front panel screw	X5200-4	Safety switch lever screw, up to #55404
X5003-2	Gear box bracket back panel screw	X5200A	Safety switch, 1 phase 115 volt, #45721 to #55404
X5003-3	Bracket reducer screw, long	X5200M	Reed safety switch, #55405 on
X5003-4	Bracket reducer screw, short	XA5245	Grant gear reducer, complete
X5004	Front panel, up to #55404	X5248	Cradle rest stud 1 1/8
X5004M	Front panel, #55405 on	X5249	Cradle rest stud screw
X5004-1	Front panel screw	X5282M	Control transformer, #55405 on
X5005	Back panel	X5285M-1	Contact, 110V, #55405 on
X5005-1	Back panel screw	X5287	Toggle switch, #51195 on #55404
X5006	End piece with block	X5287-5	Toggle switch guard, #51195 on
XA5006	End piece complete	X5287-6	Toggle switch boot, #51195 on
X5006-1	End piece screw	X5287-7	Toggle pilot light, #51195 on
X5006-2	End piece lock screw	X5287M	Toggle switch #55405 on
X5006-3	End piece lock screw nut		
X5006-5	End piece lock plate		
X5006-6	End thrust plate screw		

XHD CRADLE ASSEMBLY

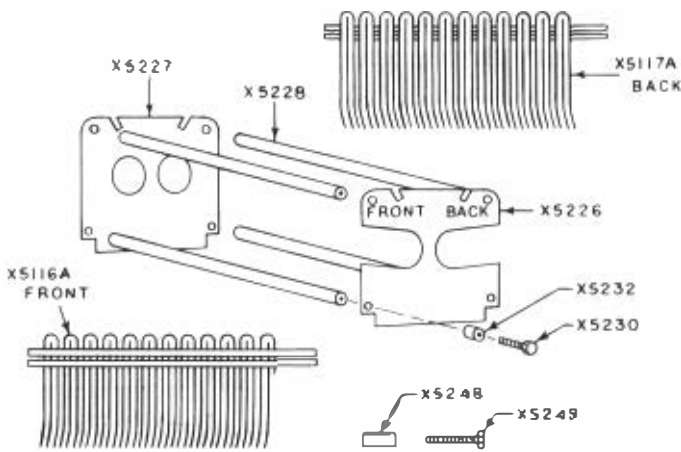

XHD STRIPPER PART NUMBERS FOR VARIOUS BLADE ASSEMBLIES

	Strippers from Above	
	Front	Back
Tenderizing	X5116A	X5117A
Scoring	X5116A	X5117A
Star Blades	X5316A	X5317A
3/8" Stew	X5116A	X5117A-5
9/16" Stew	X5116A	X5117A-4
3/8" Stew	X5116A	X5117A-1
1" Stew	X5116A	X5117A-2
1 1/4" Stew	X5116A	X5117A-3

	Strippers from Below Before Serial No. 51195	
	Front	Back
Tenderizing	X5116	X5117
Scoring	X5116	X5117
Star Blades	X5316	X5317
3/8" Stew	X5116-5	X5117-5
9/16" Stew	X5116-4	X5117-4
3/4" Stew	X5116-1	X5117-1
1" Stew	X5116-2	X5117-2
1 1/4" Stew	X5116-3	X5117-3

XHD CRADLE WITH WIRE STRIPPERS FROM ABOVE (Retrofit Conversion from Rigid Strippers from Below)

QUANTITY	ITEM NO.	DESCRIPTION
0	X5130K	XHD Cradle Conversion Kit consisting of the following parts:
1	X5130	XHD Cradle Assembly less Blades and Strippers #46109-47264
1	X5116A	XHD Wire strippers - front
1	X5117A	XHD Wire strippers - back
1	X5226	Right hand cradle end
1	X5227	Left hand cradle end
4	X5228	XHD cradle bars, front and back
8	X5230	Cradle end spacer screws
4	X5232	Cradle end spacers
4	X5248	Cradle rest studs, 1 1/8"
4	X5249	Cradle rest stud screws

XA5130Z TENDERIZER CRADLE COMPLETE

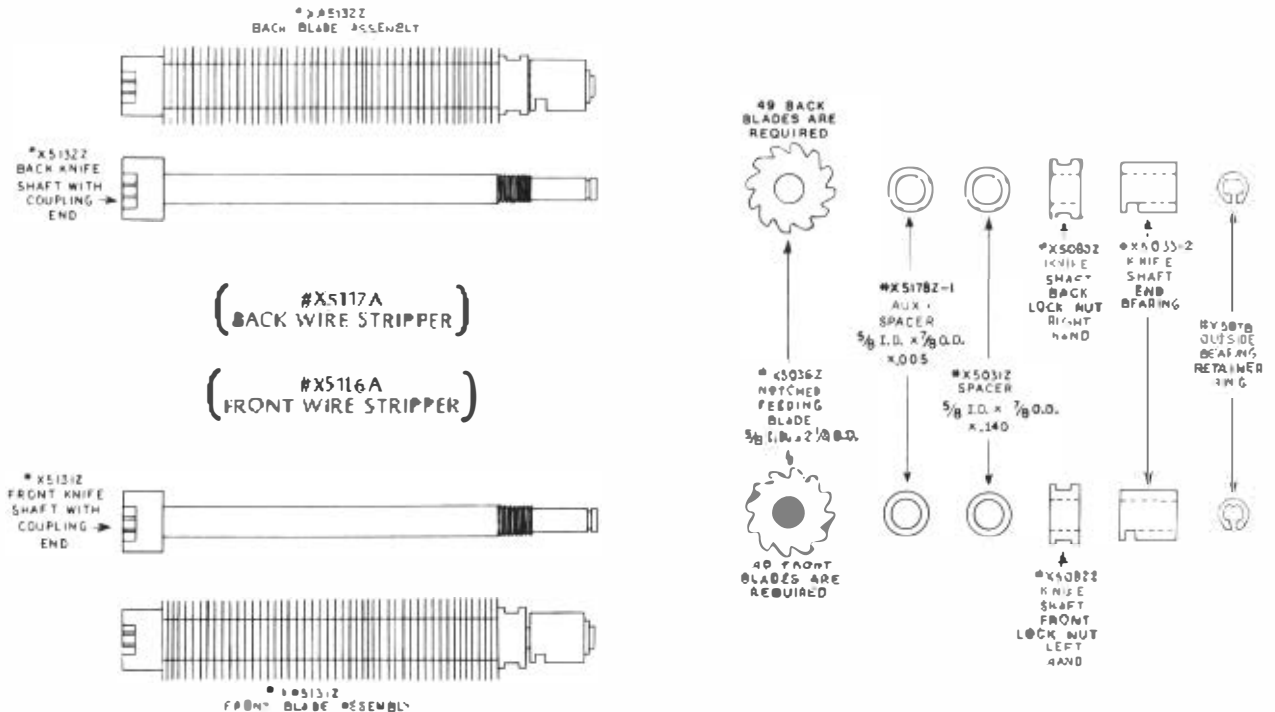

XHD SCORING BLADE PARTS

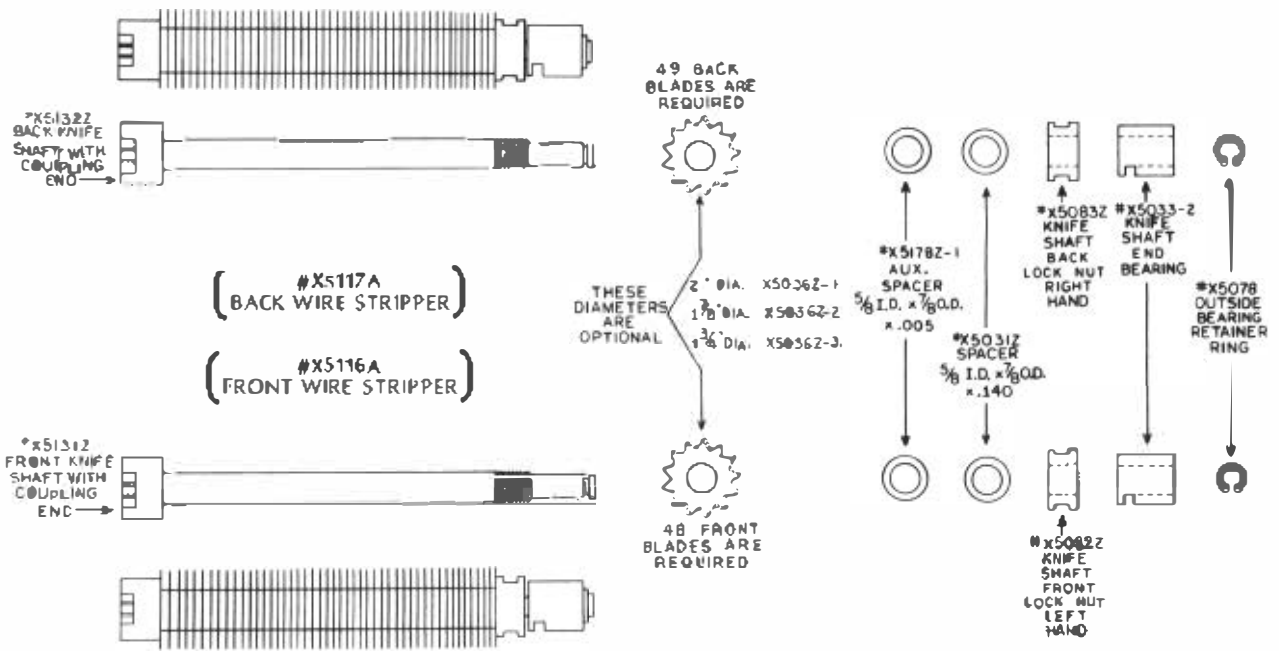

SCORING CRADLE PARTS (See parts list for other items)

Item Number	Description	FT	BK	A-DIM
XA5130Z-20A	Scoring Cradle Complete	2"	2"	0"
XA5130Z-21A	Scoring Cradle Complete	2"	1 7/8"	1/16"
XA5130Z-22A	Scoring Cradle Complete	1 7/8"	1 7/8"	1/8"
XA5130Z-23A	Scoring Cradle Complete	1 7/8"	1 3/4"	3/16"
XA5130Z-24A	Scoring Cradle Complete	1 3/4"	1 3/4"	1/4"

SCORING BLADE ARRANGEMENT FOR BIRCH-SIRSTEAK TENDERIZERS

	PATTY THICKNESS	RECOMMENDED BLADE ROLLER ASSEMBLY COMBINATION FOR 1/16" DEPTH OF SCORING ON EACH SIDE OF PATTY		
		FRONT BLADE DIA.	BACK BLADE DIA.	"B" DIMENSION
SOFT	1/8" - 1/4"	2	2	0
	1/4" - 1/2"	2	1 7/8	1/16
FROZEN	1/4"	1 7/8	1 7/8	1/8
	5/16"	1 7/8	1 3/4	3/16
	3/8"	1 3/4	1 3/4	1/4

NOTE: IF A DEEPER SCORING IS DESIRED USE THE NEXT LARGER DIAMETER BLADE ROLLER COMBINATION THAN THAT RECOMMENDED.
(ALL DIMENSIONS ARE IN INCHES)

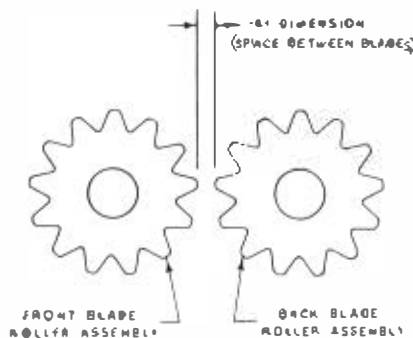

XHD SCORING BLADES AND ASSEMBLIES

Item Number	Description	Dia.
X5036Z-1	Notched Feeding Blade	2"
X5036Z-2	Notched Feeding Blade	1 7/8"
X5036Z-3	Notched Feeding Blade	1 3/4"
XA5131Z-20	Front Scoring Blade Assembly	2"
XA5131Z-22	Front Scoring Blade Assembly	1 7/8"
XA5131Z-24	Front Scoring Blade Assembly	1 3/4"
XA5132Z-20	Back Scoring Blade Assembly	2"
XA5132Z-22	Back Scoring Blade Assembly	1 7/8"
XA5132Z-24	Back Scoring Blade Assembly	1 3/4"

XA5130Z-36A STAR CRADLE COMPLETE

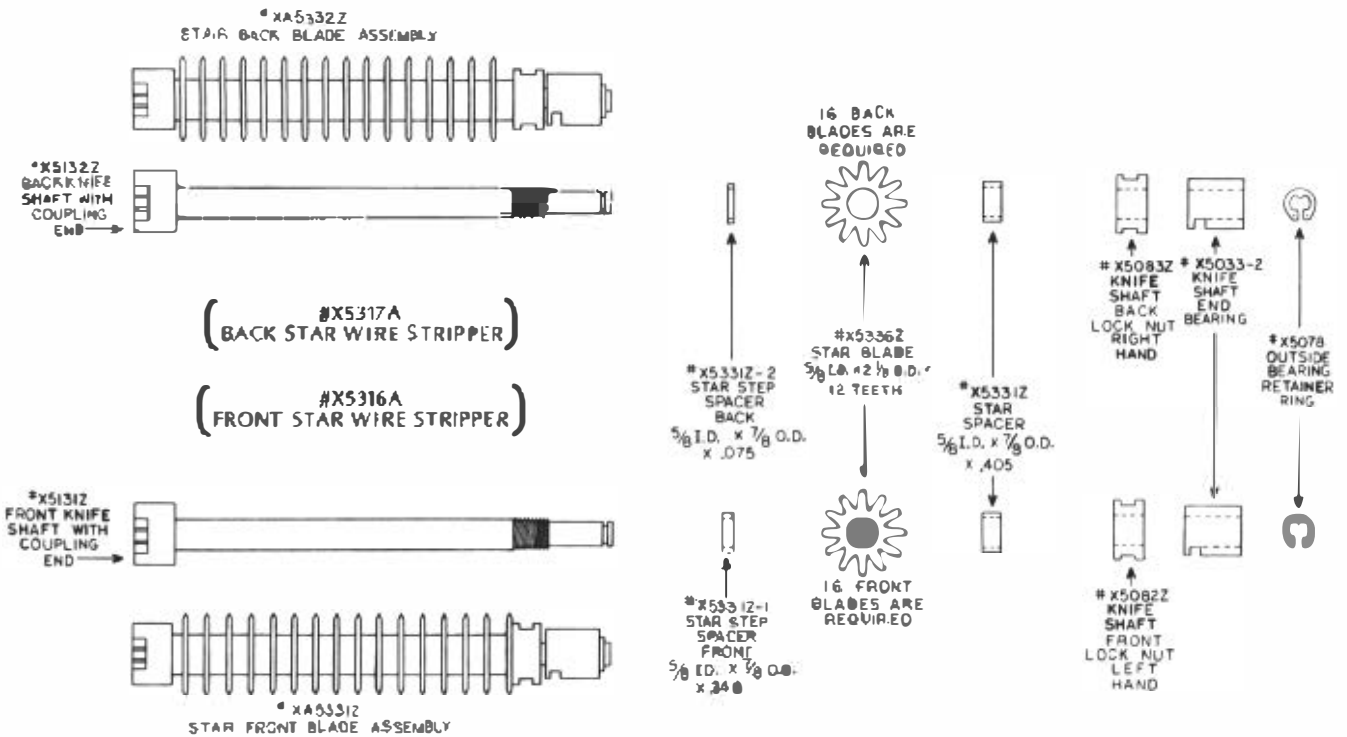

XHD STEW BLADE PARTS

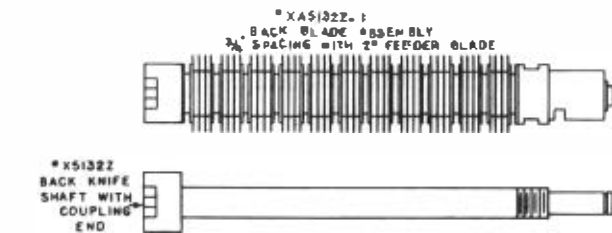

BLADE SPACING	PART NO.'S FOR VARIOUS STEW BLADE SPACING			
	FT. BLADE ASSEMBLY	BK. BLADE ASSEMBLY	FRONT STRIPPER	BACK STRIPPER
3/8"	XA5132-1	XA5132-3	X5116A	X5117A-1
1"	XA5132-2	XA5132-5	X5116A	X5117A-2
1 1/4"	XA5132-3	XA5132-3	X5116A	X5117A-3
3/16"	XA5132-4	XA5132-4	X5116A	X5117A-4
3/8"	XA5132-5	XA5132-5	X5116A	X5117A-5

BIRO MODEL XHD STEW CRADLE PARTS STEW BLADE REQUIREMENTS

Model	Blade Spacing	Blade Count
X5300Z	3/8"	21
	1/16"	16
X5036Z-1	3/16"	40
	3/4"	42
	3/4"	40
	1"	42
	1 1/4"	7
	1 1/4"	42

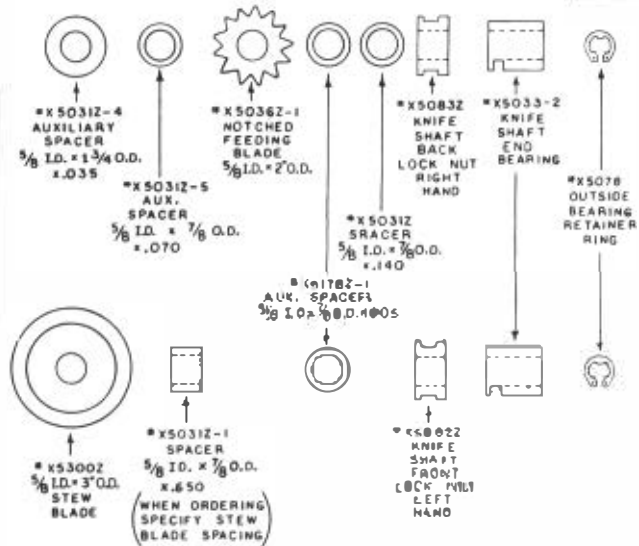
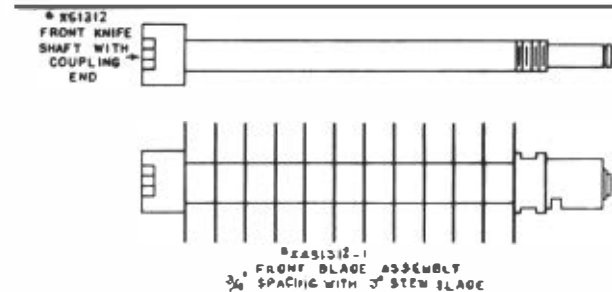

STEW CRADLE ASSEMBLIES

XA5130Z-1A Stew cradle complete, 3/4 inch
XA5130Z-2A Stew cradle complete, 1 inch
XA5130Z-3A Stew cradle complete, 1 1/4 inch

XA5130Z-4A Stew cradle complete, 3/16 inch
XA5130Z-5A Stew cradle complete, 3/8 inch

**XHD Gear Box complete with Gear Part No. XA5002-20
applicable to all XHD units starting with Serial No. 51495.
This complete gear box will interchange with all
machines having earlier serial numbers.**

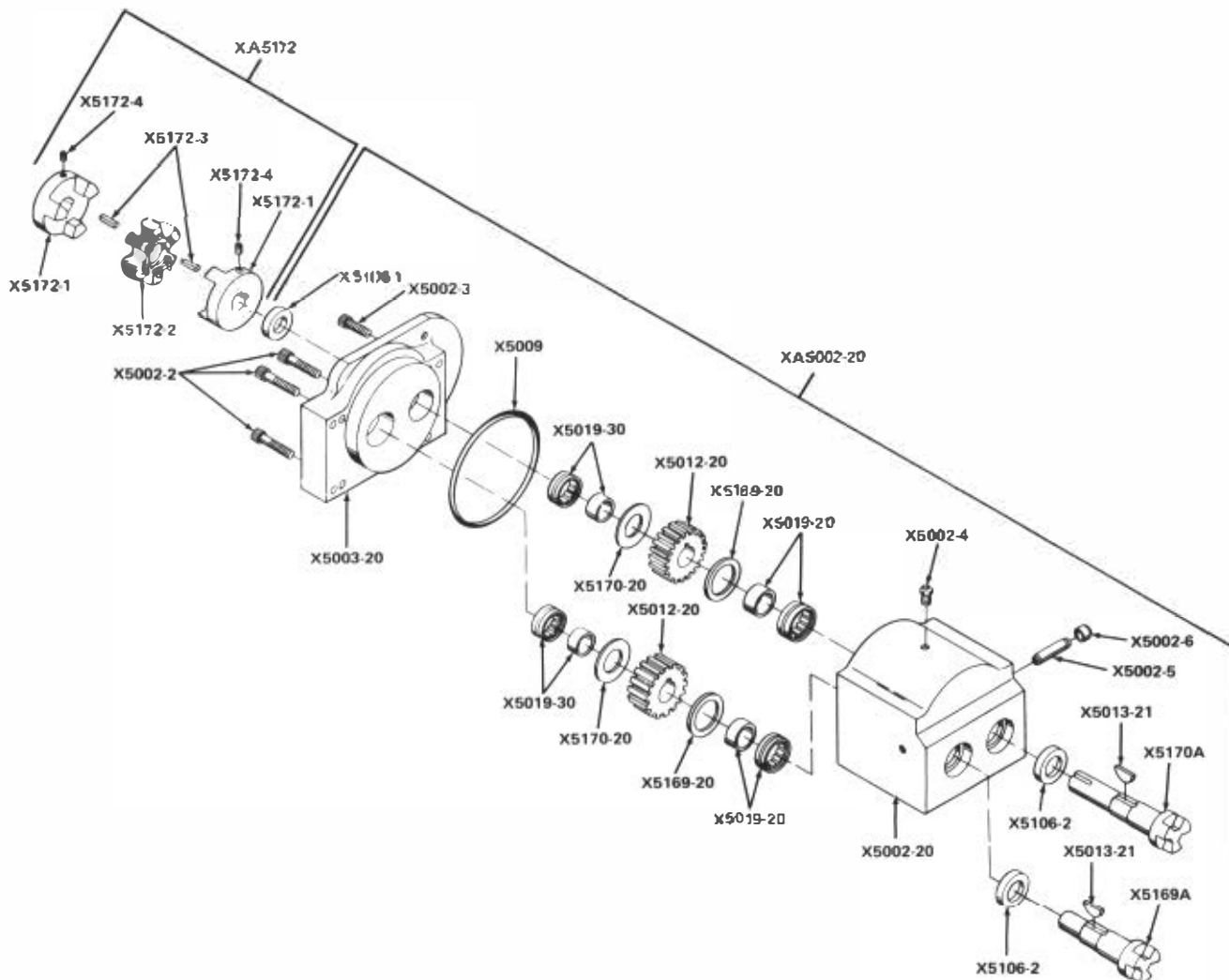

**Item
Number**

Description

X5002	Gear box *NA
X5002-1	Gear box base screw
X5002-2	Gear box bracket screw - long
X5002-3	Gear box bracket screw - short
X5003-4	Gear box vent
X5002-5	Gear box oil drain tube
X5002-6	Gear box oil drain cap
X5002-20	Gear box #51495 on *NSS
XA5002-20	Gear box complete with gears #51495 on
X5003	Gear box bracket *NA
X5003-20	Gearbox and bracket, #51495 on *NSS
X5009	O-ring gasket
X5012-20	Spur gear front & back, #51495 on
X5013-21	Spur gear Woodruff key, #53136 on
X5019-20	Needle bearing & liner front and back, RH #51495 on

Item

Number

Description

X5019-30	Needle bearing & liner front and back, LH #51495 on
X5106-1	Driven shaft oil seal
X5106-2	Coupling shaft oil seal
X5169A	Knife drive coupling, front, #53136 on
X5169-20	Spacer, front and back, RH #51495 on
X5170A	Knife drive coupling back, #53136 on
X5170-20	Spacer, front and back, LH #51495 on
X5172-1	Reducer coupling Bondtrix #39966 on
X5172-2	Reducer coupling splder #39966 on
X5172-3	Reducer coupling key #39966 on
X5172-4	Reducer coupling set screw #39966 on
XA5172	Reducer unit steel coupling, complete #39966 on

MODEL XHD TENDERIZER PARTS LIST

Important: Must have Serial Number When Ordering Parts

Item No.	Description	Item No.	Description
X5001	Base to #51195	X5031Z-1	3/4" stew spacer (5/8 I.D. x 7/8 O.D. x .650)
X5001-1	Front foot on base	X5031Z-2	1" stew spacer (5/8 I.D. x 7/8 O.D. x 1.000)
X5001-2	Back foot on base	X5031Z-3	1 1/4" stew spacer (5/8 I.D. x 7/8 O.D. x 1.175)
X5001-3	Left foot on base	X5031Z-4	Aux. spacer (5/8 I.D. x 1 9/16 O.D. x .035)
X5001-4	Foot screw on base	X5031Z-5	Aux. spacer (5/8 I.D. x 7/8 O.D. x .070)
X5001-4-1	Base foot screw lockwasher	X5031Z-9	9/16" stew spacer (5/8 I.D. x 7/8 O.D. x .475)
X5001-5	Base foot screw nut	X5031Z-11	3/8" stew spacer (5/8 I.D. x 7/8 O.D. x .300)
X5001-6	Base support screw	X5031Z-12	1 1/2" stew spacer (5/8 I.D. x 7/8 O.D. x 1.525)
X5001-7	Base support screw nut	X5031Z-13	3" blade replacement spacer (5/8 I.D. x 7/8 O.D. x .050)
X5001-8	Base grommet	X5031ZB	Spacer (5/8 I.D. x 7/8 O.D. x .105)
X5001A	Base, #51195 to #55404	X5033-2	Knifshf: end brg Delrin, #45927 on
X5001M	Front panel, #55405 on	X5036	Knife blade to #52329
X5002-1	Gear box base screw	X5036-1	Notched feeding blade, 2" to #52329
X5002-2	Gear box bracket screw, long	X5036-2	Notched feeding blade, 1 7/8" to #52329
X5002-3	Gear box bracket screw, short	X5036-3	Notched feeding blade, 1 3/4" to #52329
X5002-4	Gear box vent	X5036Z	Tendeizer knife blade (5/8 I.D. x 2 1/4 O.D. x .035)
X5002-5	Gear box oil drain tube	X5036Z-1	2" notched feeding blade
X5002-6	Gear box oil drain cap	X5036Z-2	1 7/8" notched feeding blade
X5003-1	Gear box brkt, front panel screw	X5036Z-3	1 3/4" notched feeding blade
X5003-2	Gear box brkt back panel screw	X5039-1	N/A, see cradle conversion kit #X5130K
X5003-3	Bracket reducer screw, long	X5039-1A	N/A, see cradle conversion kit #X5130K
X5003-4	Bracket reducer screw, short	X5039-2	N/A, see cradle conversion kit #X5130K
X5004	Front panel	X5039A	N/A, see cradle conversion kit #X5130K
X5004-1	Front panel screw	X5039A-10	N/A, see cradle conversion kit #X5130K
X5004M	Front panel, #55405 on	X5044	Motor mount screw
X5005	Back panel	X5045-A	Motor, 1HP, 115/220-60-1, GE
X5005-1	Back panel screw	X5045-B	Motor, 1 HP, 115/208/230-60-1, GR
X5006	End piece with block	X5045-12	Motor, 1HP, 110/220-50-1, GE
X5006-1	End piece screw	X5045-13	Motor, 1HP, 230/460-60-3, GE
X5006-2	End piece lock screw	X5045-15	Mtr, 1 1/2HP, 220/380-50/60-3, GE
X5006-3	End piece lock screw nut	X5045-15A	Mtr, 1 1/2HP, 220-380-50/60-3, GR
X5006-5	End piece lock plate	X5046	Motor junction box elbow to #51195
X5006-6	End thrust plate screw	X5046-1	Motor junct ext elbow locknut
X5006-7	End thrust plate	X5046-2	Motor junction box wire nut
X5006-8	End locking plate screw	X5059-3A	Caution decal, #51470 on
X5006-9	End finger guard	X5059-4	Warning decal, English
X5006-11	End piece finger guard screw	X5059-4-1	Warning decal, French #45379 on
X5009	O-Ring gasket	X5059-4-2	Warning decal, Spanish
X5012	Helical gear LH front, to #51495	X5061	Hopper hinge nut
X5012-20	Spur gear front & back #51495 on	X5066	Hopper hinge
X5013	Helical gear key ft & bk to 51495	X5066-2	Hopper hinge screw
X5013-1	Helical gear set screw ft & bk to #51495	X5068	Hopper hinge screw lock washer
X5013-21	Spur gear Woodruff key, #53136 on	X5078	Outside bearing ring
X5014	Helical gear, RH back to #51495	X5082	Knife shaft front lock nut, LH to #51195
X5019-2	Needle bearing & liner, f., RH to #51495	X5082Z	Front 5/8" knife shaft lock nut, LH
X5019-3	Needle bearing & liner, f., LH to #51495	X5083	Knife shaft back lock nut, RH to #51195
X5019-4	Needle bearing & liner, bk, RH to #51495	X5083Z	Back 5/8" knife shaft lock nut, RH
X5019-5	Needle bearing & liner, bk, LH to #51495	X5096-1	Transprt hopper w/intlk swactv to #55404
X5019-20	Needle bearing & liner, front & back, RH #51495 on	X5096M	Aluminum safety cover w/magnet #55405 on
X501930	Needle bearing & liner, front & back, LH #51495 on	X5096M-1	Transparent safety cover w/magnet #55405 on
X5031-1	Spacer for 3/4" stew to #52329	X5106-1	Driven shaft oil seal
X5031-2	Spacer for 1" stew to #52329	X5106-2	Coupling shaf: oil seal
X5031-3	Spacer for 1 1/4" stew to #52329	X5108-1	Motor cord, 3 wire
X5031-4	Aux. spacer 3/4 x 1 3/4 x .035 to #52329	X5108-2	Motor cord, 4 wire
X5031-5	Aux. spacer 3/4 x .955 x .070 to #52329	X5108-2A	Motor cord, 4 wire, #51195 on
X5031-9	Spacer for 9/16" stew to #52329	X5108-3	Motor extension cord 1 & 3 phase, #51195 on
X5031-11	Spacer for 3/8" stew to #52329	X5108-4	Motor extension cord, 220V
X5031-12	Spacer for 1 1/2" stew to #52329	X5108-5	Motor cord plug, 115V
X5031-13	Spacer 3" blade replacement to #52329	X5108-6	Motor cord pug, 220V, 1PH
X5031A	Knife spacer, 3/4 ID x 1 OD x .140 to #52329		
X5031B	Knife spacer, 3/4 ID x 1 OD x .105 to #52329		
X5031Z	Spacer (5/8 I.D. x 7/8 O.D. x .140)		

Item No.	Description	Item No.	Description
X5108-7	Motor cord plug 220/440V, 3PH	X5200-4	Safety switch lever screw
X5116	Rigid strpr, f., to #46108 & #47264 up to #51195	X5200-5	Safety switch screw, 1 phase
X5116-1	Stew rigid stripper, ft, 3/4" to #51195	X5200-7	Safety switch lockwasher
X5116-2	Stew rigid stripper, ft, 1" to #51195	X5200-8	Safety switch splash baffel, 1PH
X51163	Stew rigid stripper, ft, 1 1/4" to #51195	X520 0-9	Safety switch splash baffel, 3PH
X51164	Stew rigid stripper, ft, 9/16" to #51195	X5200A	Sfry switch, 1PH, 115V, #45721 to #55404
X5116-5	Stew rigid stripper, ft, 3/8" to #51195	X5200M	Reed safety switch, #55405 on
X5116A	Stripper, wire, front, #51195 on	X5226	Right hand cradle end, #51195 on
X5117	Rigid strpr, bk, to #46108 & #47264 up to #51195	X5227	Left hand cradle end, #51195 on
X5117-1	Rigid stripper, back, 3/4" to #51195	X5228	Cradle bar back & front, #51195 on
X5117-2	Rigid stripper, back, 1" to #51195	X5230	Cradle end spacer screw, #51195 on
X5117-3	Rigid stripper, back, 1 1/4" to #51195	X5232	Cradle end spacer, #51195 on
X5117-4	Rigid stripper, back, 9/16" to #51195	XA5245	Grant gear reducer, complete, #35940 on
X5117-5	Rigid stripper, back, 3/8" to #51195	X5245-1	Housing
X5117A	Stripper wire, back, #51195 on	X5245-2	Worm gland closed
X5117A-1	Wire stripper, back, 3/4", #51195 on	X5245-3A	Motor flange
X5117A2	Wire stripper, back, 1", #51195 on	X5245-4	Worm gear gland closed
X5117A-3	Wire stripper, back, 1 1/4", #51195 on	X5245-5A	Worm gear gland open
X5117A-4	Wire stripper, back, 9/16", #51195 on	X5245-6	Worm & shaf: Integral
X5117A-5	Wire stripper, back, 3/8", #51195 on	X5245-7	Worm gear
X5130	Crade, #46109-47264, #51195 on	X5245-8A	Worm gear shaft
X5130K	Cradle conversion kit, fits all	X5245-9	Worm ball bearing, HI speed
X5131	Front knife shaft w/cplg end, LH to #52329	X5245-10	Worm ball bearing, LO speed
X5131-10	Front blade assembly, complete to #52329	X5245-11	Motor flange gasket
X5131-10-1	Front blade assembly, 3/4" to #52329	X5245-12	Gear gland gasket
X5131-10-2	Front blade assembly, 1" to #52329	X5245-13	Motor flange oil seal, HI speed
X5131-10-3	Front blade assembly, 1 1/4" to #52329	X5245-14	Motor flange oil seal, LO speed
X5131-10 4	Front blade assembly, 9/16" to #52329	X5245-15	Worm gear key
X5131-10-5	Front blade assembly, 3/8" to #52329	X5245-16	Worm gland/ flange cap screw
X5131-10-20	Front scor bld assembly, 2" to #52329	X5245-17	Breather plug
X5131-10-22	Front scor bld assembly, 1 7/8" to #52329	X5245-18	Oil level pipe plug
X5131-10-24	Front scor bld assembly, 1 3/4" to #52329	X5245-19	Oil drain pipe plug
X5131Z	5/8" front knife shaft with coupling end - LH	X5245-21	Worm snap ring
X5132	Back knife shaft w/cplg end to #52329	X5248	Cradle rest stud, 1 1/8", #51195 on
X5132-10	Back blade assembly, complete to #52329	X5249	Cradle rest stud screw, #51195 on
X5132-10-1	Back blade assembly, 3/4" to #52329	X5282M	Control transformer #55405 on
X5132-10-2	Back blade assembly, 1" to #52329	X5284M	Transformer screw
X5132-10-3	Back blade assembly, 1 1/4" to #52329	X5284M-6	Transformer flat washer
X5132-10-4	Back blade assembly, 9/16" to #52329	X5284M-8	Transformer lock washer
X5132-10-5	Back blade assembly, 3/8" to #52329	X5285M-1	Contacto, 110V, #55405 on
X5132-10-20	Back scor bld assembly, 2" to #52329	X5286	Contacto screw
X5132-10-22	Bk scor bld assembly, 1 7/8" to #52329	X5287	Toggle switch, #51195 to 55404
X5132-10-24	Bk scor bld assembly, 1 3/4" to #52329	X5287-5	Toggle switch guard, #51195 on
X5132Z	5/8" back knife shaft with coupling end - RH	X5287-6	Toggle switch boot, #51195 on
X5169-20	Spacer, front & back, RH, #51495 on	X5287-7	Toggle plot light, #51195 on
X5169A	Knife drive coupling, front, #53136 on	X5287M	Toggle switch, #55405 on
X5170A	Knife drive coupling, back, #53136 on	X5300	Stew cutting blade, 3", #52329
X5170-20	Spacer, front & back, LH #51495 on	X53002	3" stew blade for 5/8" shaft
X5172-1	Reducer cplg Bondtru #39966 on	X5316	Star rigid stripper, front, to #52329
X5172-2	Reducer cplg spider #39966 on	X5316A	Star wire stripper, front, #51195 on
X5172-3	Reducer coupling key #39966 on	X5317	Star rigid stripper, back, to #51195
X5172-4	Reducer cplg set screw #39966 on	X5317A	Star wire stripper, back, #51195 on
XA5172	Reder unit stlcplg, comp #39966 on	X5331	Star spacer, 3/4 x 1 x .405, front & back, to #52329
X5178-1	Auxiliary spacer #47108 to #52329	X5331-1	Star step spacer front, 3/4 x 1 x .240, to #52329
X5178Z:1	Auxiliary spacer (5/8 I.D. x 7/8 O.D. x .005)	X5331-2	Star step spacer back, 3/4 x 1 x .075, to #52329
X5185	Drum switch, Furnas 3PH WJ2, to #51495	X5331-10	Star front blade assembly, to #52329
X5187	Drum switch, Furnas 1PH WR327A, to #51495	X5331Z	Front & back star spacer (5/8 I.D. x 7/8 O.D. x .405)
X5187-1	Drum switch bracket to #51495	X5331Z-1	Front star step spacer, (5/8 I.D. x 7/8 O.D. x .240)
X5187-2	Drum switch bracket screw to #51495	X5331Z-2	Back star step spacer, (3/8 I.D. x 7/8 O.D. x .075)
X5187-3	Drum switch bracket screw to #51495	X5332-10	Star back blade assembly, to #52329
X5187-4	Drum switch nut lockwasher to #51495	X5336	Star blade, to #52329
X5187-5	Drum switch screw nut to #51495	X5336Z	Star blade for 5/8" shaft
X5188	Drum switch connector to #51495	X5400-089	XHD Operating Manual
X5189	Drum switch elbow to #51495		
X5190	Drum switch elbow connector to #51495		
X5200-1A	Sfry switch, 3PH 220V & 1PH 220V to #55404		

ASSEMBLY NUMBERS FOR THE XHD MACHINE

Item No.	Description	Item No.	Description
XA5002-20	Gear box complete with gears, #51495 on	XA5131Z-4	9/16" stew front blade assembly
XA5006	End piece, complete	XA5131Z5	3/8" stew front blade assembly
XA5130Z	Standard tenderizer cradle, complete	XA5131Z-20	2" front scoring blade assembly
XA5130Z-1A	3/4" stew cradle, complete	XA5131Z-22	17/8" front scoring blade assembly
XA5130Z-2A	1" stew cradle, complete	XA5131Z-24	13/4" front scoring blade assembly
XA5130Z-3A	1 1/4" stew cradle, complete	XA5132Z	Tenderizer back blade assembly
XA5130Z-4A	9/16" stew cradle, complete	XA5132Z-1	3/4" stew back blade assembly
XA5130Z-5A	3/8" stew cradle, complete	XA5132Z-2	1" stew back blade assembly
XA5130Z-20A	Scoring cradle comp. 2" ft & 2" bk	XA5132Z-3	1 1/4" stew back blade assembly
XA5130Z-21A	Scoring cradle comp. 2" ft, 17/8" bk	XA5132Z-4	9/16" stew back blade assembly
XA5130Z-22A	Scoring cradle comp. 17/8" ft. & 17/8" bk	XA5132Z-5	3/8" stew back blade assembly
XA5130Z-23A	Scoring cradle comp. 17/8" ft. 13/4" bk	XA5132Z-20	2" scoring back blade assembly
XA5130Z-24A	Scoring cradle comp. 13/4" ft. & 13/4" bk	XA5132Z-22	17/8" scoring back blade assembly
XA5130Z-36A	Star cradle complete	XA5132Z-24	13/4" scoring back blade assembly
XA5131Z	Tenderizer front blade assembly, complete	XA5172	Reducer unit steel coupling, complete
XA5131Z-1	3/4" stew front blade assembly	XA5245	Grant gear reducer, complete
XA5131Z-2	1" stew front blade assembly	XA5331Z	Star front blade assembly
XA5131Z-3	1 1/4" stew front blade assembly	XA5332Z	Star back blade assembly

LIMITED WARRANTY:

WARRANTY: The Biro Manufacturing Company warrants that Model XHD Heavy Duty Tenderizer will be free from defects in material and workmanship under normal use and with recommended service. BIRO will replace defective parts, which are covered by this limited warranty, provided that the defective parts are authorized for return, shipping charges prepaid, to a designated factory for inspection and/or testing.

DURATION OF WARRANTY: The warranty period for all parts covered by this limited warranty is one (1) year from inspection/demonstration advised on the returned Warranty registration card, or eighteen (18) months from original factory ship date, whichever date occurs first, except as noted below.

PARTS NOT COVERED BY WARRANTY: The following wearable parts are not covered by this limited warranty: tenderizer blades, 3" stew blades, scoring blades, star blades, feeder blades, cutlet blades, and all front and rear wire combs. This limited warranty does not apply to machines sold as used, rebuilt, modified, or altered from the original construction in which the machine was shipped from the factory. (Water contaminated electrical systems are not covered under this limited warranty). BIRO is not responsible for service charges or labor required to replace any part covered by this limited warranty or for any damages resulting from misuse, abuse, lack of proper or recommended service, or for electrical connection of equipment, adjustments to switch gear or any other electrical requirements, which must be performed only by a certified electrician.

EXCLUSION OF WARRANTIES AND LIMITATION OF REMEDIES: BIRO gives no warranties other than those expressly stated in this limited warranty. THE IMPLIED WARRANTY OF MERCHANTABILITY, THE IMPLIED WARRANTY OF FITNESS FOR PROCESSING OF FOOD PRODUCTS, AND ALL OTHER IMPLIED WARRANTIES ARE SPECIFICALLY EXCLUDED. BIRO IS NOT LIABLE FOR CONSEQUENTIAL OR INCIDENTAL DAMAGES, EXPENSES, OR LOSSES. THE REMEDIES PROVIDED IN THIS BIRO LIMITED WARRANTY ARE PURCHASER'S SOLE AND EXCLUSIVE REMEDIES AGAINST BIRO.

REGISTRATION CARDS: You must sign, date and complete warranty registration card supplied with each machine. The warranty card must be returned to The Biro Manufacturing Company for proper registration. If no warranty card is returned to BIRO, the warranty period will begin from the date the machine was originally shipped from the factory.

HOW TO GET SERVICE:

1. Contact the agency from whom you purchased the machine.
2. Consult the yellow pages of the phone directory for the nearest authorized dealer.
3. Or call BIRO Service Department (419) 798-4451, who will put you in contact with the nearest service agency.