



**MODEL VTS-500
VACUUM TUMBLER
OPERATING AND SERVICE MANUAL
STARTING WITH SERIAL No. 602**



☆ **IMPORTANT NOTICE** ☆

This Manual contains important safety instructions which must be strictly followed when using this equipment.

TABLE OF CONTENTS:

	PAGE
NOTICE TO OWNERS AND OPERATORS	1
SAFETY TIPS	2
OPERATION	3
CLEANING	4
MAINTENANCE	5
PUMP FILTER	5-7
VACUUM PUMP	8-9
GEAR REDUCER	10-11
TO PROGRAM EAGLE TIMER	12
TO PROGRAM RED LION PAXTM TIMER	13-16
TIMER PROGRAM NOTES	17
PHOTOELECTRIC EYE	18-19
CONTROL PANEL - COMPONENTS	20
CONTROL PANEL - REAR VIEW	21-23
DRUM ASSEMBLY	24
FRAME ASSEMBLY AND COMPONENTS	25
VACUUM HOSES AND FITTINGS	26
COMPONENT COVER AND REAR DOOR	27
PREVENTATIVE MAINTENANCE	28
WIRING DIAGRAMS	29-32
RECOMMENDED SPARE PARTS	33
COMMON DECALS	34
OPERATOR'S SIGNATURE PAGE	35
LIMITED WARRANTY	36

NOTICE TO OWNERS AND OPERATORS

BIRO's products are designed to process food products safely and efficiently. Unless the operator is properly trained and supervised, however, there is the possibility of a serious injury. It is the responsibility of the owner to assure that this machine is used properly and safely, strictly following the instructions contained in this Manual and any requirements of local law.

No one should use or service this machine without proper training and supervision. All operators should read and be thoroughly familiar with the procedures contained in this Manual. Even so BIRO cannot anticipate every circumstance or environment in which its products will be used. You, the owner and operator, must remain alert to the hazards posed by the function of this equipment. No one under eighteen (18) years of age should operate this equipment. If you are uncertain about a particular task, ask your supervisor.

This Manual contains a number of safe practices in the SAFETY TIP section. Additional warnings are placed throughout the Manual. Warnings related to your personal safety are indicated by:



OR



Warnings related to possible damage to equipment are indicated by:



BIRO also has provided warning labels on the equipment. If any warning label, instruction label or Manual becomes misplaced, damaged, or illegible, please contact your nearest Distributor or BIRO directly for a replacement.

Remember, however, this Manual or the warning labels do not replace the need to be alert and to use common sense when using this equipment.

- NOTE -

A copy of this manual is included with each MODEL VTS-500 VACUUM TUMBLER.

**The descriptions and illustrations contained in this manual are not binding.
The manufacturer reserves the right to introduce any modification without
updating the manual.**

SAFETY TIPS



ROTATING DRUM TO AVOID SERIOUS PERSONAL INJURY

***NEVER** Touch This Machine Without Training and Authorization By Your Supervisor.*

***ALWAYS** Read Operation and Parts Manual **BEFORE** Operating, Cleaning or Servicing.*

***ALWAYS** Keep Hands Clear of Rotating Drum and Other Moving Parts.*

***ALWAYS** Maintain a Minimum Distance of 12" From Back of Machine to Nearest Object, for Rotating Drum.*

***NEVER** Attempt to Remove the Drum Lid Unless Vacuum Has been Released and the Drum is Positioned Vertically With the Lid at the Top.*

***NEVER** Operate Vacuum Pump Unless Vacuum Hose is Properly Connected to Hose Hanger or Tumbler Drum.*

***ONLY** Operate Vacuum Pump in Recommended Vacuum Range (15-20 Inches of Mercury)
NEVER TO EXCEED 20 INCHES Hg.*

***ONLY** Use a Qualified Electrician to Install According to Local Building Codes: Machine **MUST** Be Properly Grounded.*

***ONLY** Install on Level, Non-Skid Surface in a Clean, Well-Lighted Work Area Away From Children and Visitors.*

***DO NOT** Allow Food Particles, Liquids or Any Other Foreign Material to Enter the Vacuum Pump or Vacuum Hose.*

***ALWAYS** Turn Off, Unplug From Power Source and Perform Lockout/Tagout Procedure to This Machine **BEFORE** Cleaning or Servicing.*

***NEVER** Leave Machine Unattended While Operating.*

***PROMPTLY REPLACE** Any Worn or Illegible Warning and/or Instruction Labels.*

***USE ONLY BIRO** Parts and Accessories Properly Installed.*

A. FOOD HANDLING TO PREVENT CONTAMINATION

1. **ALWAYS** wash hands thoroughly with warm soap and water before and after handling raw fish, poultry or meats.
2. **ALWAYS** clean and sanitize all utensils and surfaces that have been in contact with raw products.
3. **ALWAYS** store cold foods at or below 45 deg. F (7.2 deg. C).

OPERATION



ROTATING DRUM

***ONLY** Properly Trained Personnel Should Use This Equipment.*

***ALWAYS** Keep Hands Clear of the Rotating Drum and Other Moving Parts.*

***ALWAYS** Maintain a Minimum Distance of 12” From Back of Machine to Nearest Object, for Rotating Drum.*

***DO NOT** Tamper With, Bypass, Alter, or Modify this Equipment in Any Way From Its Original Condition.*

***ALWAYS** Turn Off, Unplug From Power Source and Perform Lockout/Tagout Procedure to This Machine **BEFORE** Cleaning, Servicing, or When Not In Use.*

***NEVER** Leave Unattended While Operating.*

***NEVER** Turn Drum by Hand, Use Jog Switch to Jog Drum Until Opening is in Upright Position.*

***ALWAYS** Comply With All Regulation for Food Handling, Packaging, and Storage.*

***NEVER** Operate Without All Warning or Instruction Labels Attached.*

TO PROCESS PRODUCT AND MACHINE OPERATION

1. Weigh product to be vacuum tumbled.
2. Refer to your ingredient chart for proper amount of marinade seasoning and water.
3. Use jog switch to position drum opening upright.
4. Place product, marinade and water into tumbler drum.
5. Install gasket on cover and place cover on drum and secure with four latches.
6. Connect vacuum hose to valve on drum. Be sure valve handle is in the open position, parallel with the valve body.
7. Turn vacuum pump to “ON”. (Vacuum gauge will start indicating a vacuum is being pulled in the drum.) If needle in vacuum gauge does not indicate vacuum is being pulled, turn “OFF” vacuum pump and disconnect vacuum hose from drum. Remove drum lid and check that the lid gasket is properly installed and seated, then repeat this procedure.
8. When vacuum gauge does indicate that a vacuum is being pulled, allow to continue running until gauge reads between 15 and 20 inches Hg. **NEVER TO EXCEED 20” Hg.**
9. Close valve handle on drum, Perpendicular to valve body. Turn vacuum pump to”OFF” position. Remove vacuum hose from valve. Drum contents are now sealed in a vacuum.
10. Program timer to desired process time, and press green button to start, drum will start turning.
11. Turn speed control knob to desired RPM.
12. Drum will stop when time runs out.
13. Turn off motor, press black jog button until drum opening is in upright position. Or turn black selector switch, if equipped with forward/reverse jog option. **NEVER TURN DRUM BY HAND.**
14. Turn valve handle to open position parallel with valve body to release vacuum. Remove drum lid.
15. Remove product from drum.
16. Unplug machine and refer to cleaning instructions.

CLEANING



ROTATING DRUM

TO AVOID SERIOUS PERSONAL INJURY

ALWAYS Turn Off, Unplug From Power Source and Perform Lockout/Tagout Procedure to This Machine **BEFORE** Cleaning or Servicing.

ONLY Use Recommended Cleaning Equipment, Materials and Procedures.

NEVER Spray Water or Other Liquid Substances Directly at Motor, Power Switch or any Other Electrical Components.

ALWAYS Thoroughly Clean Equipment at Least Daily.



DO NOT Use Harsh Chemicals, Scouring Pads or Cleansers. Ordinary Liquid Detergent for Manual Dish Washing or Pot/Pan Washing Will Not Harm the Machine. Dish Machine Chemicals Will Cause Brown Stains, as will Chlorine Bleach and Similar Products if Allowed to Stand in or on the Machine for Any Length of Time.

CLEANING THE BIRO VACUUM TUMBLER:

1. Turn “OFF”, unplug machine from power source, and perform lockout/tagout procedures.
2. The drum, drum lid, and gasket can be removed and washed in utensil sink. Be sure to flush the vacuum valve on drum with soapy water and rinse with clean water thoroughly. The drum, drum lid and gasket should be sanitized with an appropriate sanitizer approved by your local Health Dept. All parts should be air dried before reassembly and storage.
3. The exterior of the tumbler base and drum can be pressure washed with the same type soap solution followed by a rinse water wiping.
4. If food stains are not removed, use a product such as “Bon Ami” or “Soft Scrub”. Be sure to scrub with the grain of the Stainless Steel with a soft cloth or sponge.
5. Streaks or water spots can usually be removed with a solution of vinegar and water.

MAINTENANCE



ROTATING DRUM

TO AVOID SERIOUS PERSONAL INJURY

ALWAYS Turn Off, Unplug From Power Source and Perform Lockout/Tagout Procedure to This Machine **BEFORE** Cleaning or Servicing.

NEVER Touch This Machine Without Training and Authorization By Your Supervisor.

NEVER Bypass, Alter, or Modify this Equipment in Any Way From Its Original Condition.

PROMPTLY REPLACE Any Worn or Illegible Warning and/or Instruction Labels.

USE ONLY GENUINE BIRO Parts and Accessories Properly Installed.

A. PUMP FILTER No. **VT529**

1. Check filter daily. Filter must be drained before the separated moisture and oil reaches the bottom of the lower black baffle. Drain by unscrewing the black drain plug in bottom of sight bowl.
2. The filter element No. **VT529-1** should be removed and cleaned monthly.
 - a. Unscrew the black locking collar.
 - b. Remove the bowl and locking collar.
 - c. Unscrew the black baffle at the bottom of the filter.
 - d. Clean bowl and filter element. Reinstall the filter element. Clean bowl with mild soap and water only. Do not use detergents, cleansing agents, such as acetone, alcohol, benzene or gasoline, which are damaging to plastic.
 - e. Lubricate bowl lip to assist initial sealing. Use only mineral based oils or grease. Do not use synthetic oils or silicones.



LOCKING COLLAR

DRAIN

VTSS529 FILTER MAINTENANCE

DAILY: Drain all separated moisture and oil from the filter enclosure. Unscrew the black drain plug at the bottom of the sight bowl.



MONTHLY: Part No. [VTSS529-1](#) filter element must be replaced once a month for a proper vacuum and pump operation.



1. Unscrew the bowl locking collar.

2. Remove the clear bowl and locking collar and set aside.



3. Unscrew the filter holder. Lower the filter carefully from the mounting stud. Note the order of parts.



4. Separate the filter from the filter holders. Replace with a new filter.



5. Reassemble the filter in the reverse order. **Take special care that the locking ring is fully seated and tight. HAND TIGHTEN ONLY.**



Item No. VTS529-1 filter element must be replaced once a month for proper vacuum pump operation. One (1) replacement filter has been included with your tumbler. Order replacement filters, Item No. VTS529-1 from the agency from whom you purchased the machine as needed.

NOTE: Review filter instructions in operation and service manual.

RECOMMENDED TECHNIQUE

After filling the drum with product and marinades.

Install gasket and lock the drum cover down.

Jog the drum until the vacuum fitting is pointing up as shown below, this will help minimize the possibility of liquid being drawn into the vacuum pump.

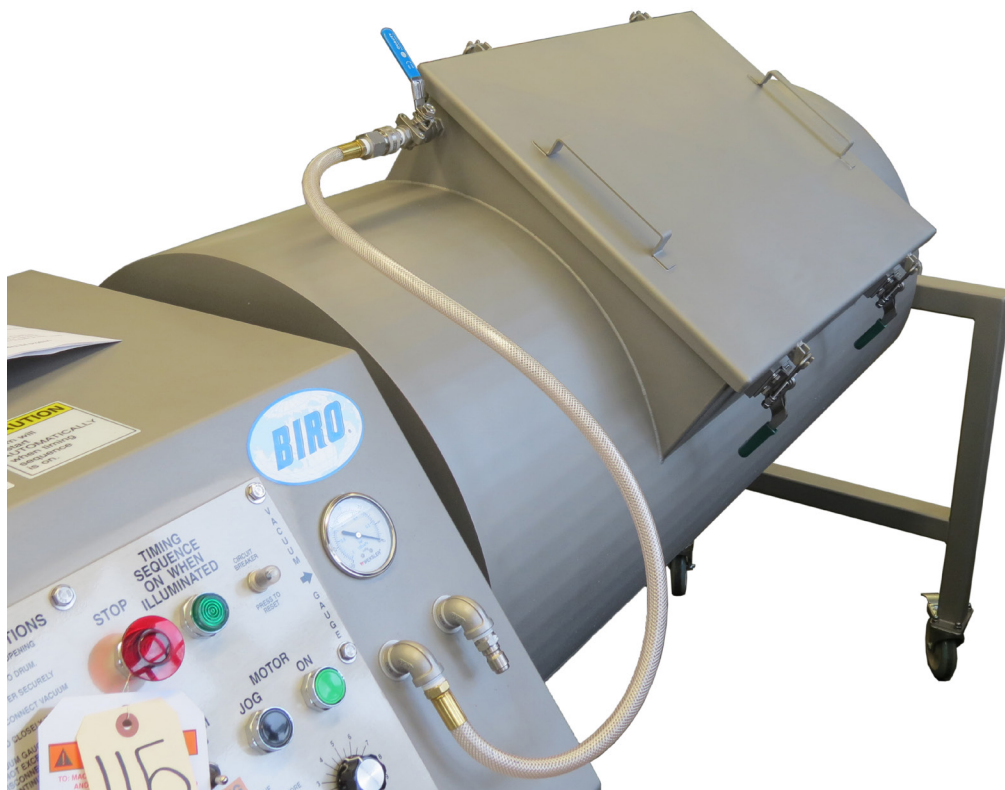

VACUUM PUMP MAINTENANCE



MAKE SURE THE ELECTRIC MOTOR IS PROPERLY GROUNDED AND THE WIRING IS DONE BY A QUALIFIED ELECTRICIAN FAMILIAR WITH NEMA MG2 SAFETY STANDARDS, NATIONAL ELECTRICAL CODE AND ALL LOCAL SAFETY CODES.

THE MOTOR IS THERMALLY PROTECTED AND CAN AUTOMATICALLY RESTART WHEN THE OVERLOAD RESETS. ALWAYS DISCONNECT FROM POWER SOURCE BEFORE SERVICING. PERSONAL INJURY COULD BE THE RESULT.

DO NOT USE KEROSENE OR OTHER COMBUSTIBLE SOLVENTS TO FLUSH UNIT. USE ONLY GAST BRAND AH255 FLUSHING SOLVENT OR EQUIVALENT.

1. **CONSTRUCTION:** The end plate, body, rotor and all mounting brackets are cast iron. Any moisture that accumulates in the pump will tend to corrode the interior, especially if it stands idle. The muffler box, on the front of the unit, is made of aluminum. The vanes are made of hard carbon and are precision ground. They should last many thousand hours depending on degree of vacuum at which the pump is run.
2. **STARTING:** *CAUTION: NEVER LUBRICATE THIS OIL-LESS AIR PUMP.* The carbon vanes and grease packed motor bearings require no oil. If the motor fails to start or slows down when under load, shut the unit off and unplug. Check that the supply voltage agrees with the motor post terminals and motor data name plate. If the pump is extremely cold, allow it to warm to room temperature before starting.
3. **FLUSHING:** Should excessive dirt, foreign particles, moisture, or oil be permitted to enter the pump the vanes will act sluggish or even break. Flushing the pump should remove these materials. There are two options for performing this operation. **Option 1:** You will need two pipe nipples at least 4" long with 3/8" NPT on one end. 1) Remove the filter elements from the front of the muffler box and screw the nipples in through the same holes. 2) With the pump running allow about 2 tbsp. of flushing solvent to be ingested into the vacuum side of the unit. *CAUTION: WEAR EYE PROTECTION AND FLUSH IN A WELL VENTILATED AREA.* Repeat the flushing procedure. If it does not remedy the situation, remove the end plate for further examination. **Option 2:** Remove the filter elements from the front of the muffler box and carefully remove the five bolts that hold the muffler box in place (be careful not to damage the gaskets and it may be necessary to replace them). Tap the box with a small hammer to break it loose. **DO NOT PRY WITH A SCREWDRIVER** as the gasket will be damaged. This will allow access to the intake and exhaust ports.
4. **DISASSEMBLY:** If flushing does not eliminate the problem, remove the six bolts holding the end plate to the body. Now remove the end plate and the four vanes (do not remove the rotor or loosen any electric motor through bolts). The vanes could be worn or could require further cleaning. The top clearance (between the rotor and body) may be adjusted by: 1) loosen body bolts, 2) lightly tap on the pump body and turn the rotor while setting this clearance to assure all points on the rotor clear the body.

REASONS FOR PROBLEM	LOW		HIGH		PUMP OVERHEATING	MOTOR OVERLOAD
	VAC.	PRESS.	VAC.	PRESS.		
Filter dirty	X	X	at pump		X	X
Muffler dirty				at pump	X	X
Vacuum line collapsed	X		at pump		X	X
Relief valve set too high			X	X	X	X
Relief valve set too low	X	X				
Plugged vacuum line	X	X	at pump	at pump	X	X
Vanes sticking	X	X				
Running at too high RPM			X	X	X	X
Vanes worn (replace)	X	X				
Shaft seal worn (replace)	X	X				
Dust or offset powder in pump	X	X			X	X
Motor not wired correctly	X	X			X	

VTS1034-1
¾ HP VACUUM PUMP

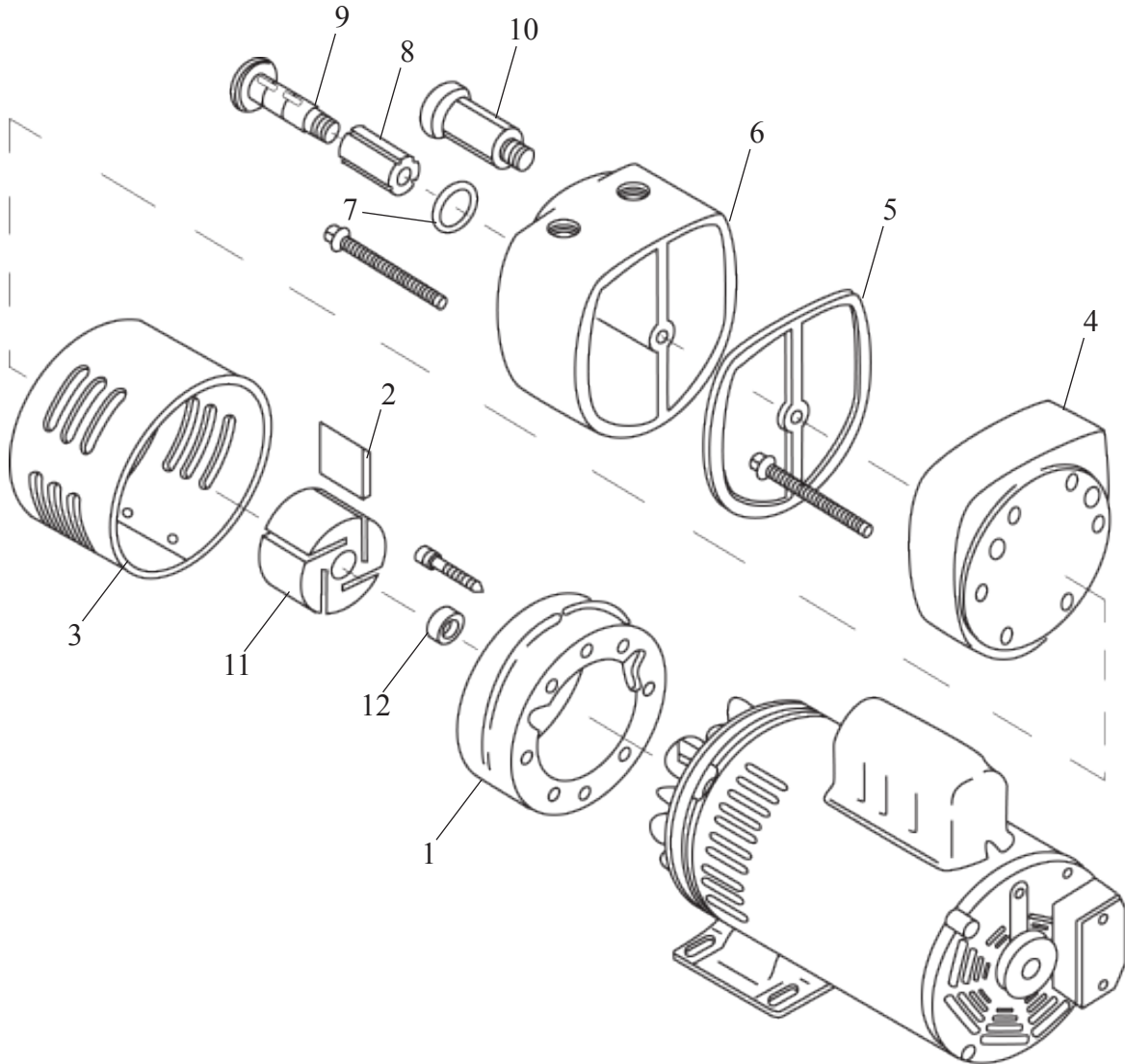

Fig.	Item No.	Description	Qty.
1	VTS-AK518	Pump body	1 req'd
*2	VTS-AK513	Vane	4 req'd
3	VTS-AK511	Pump shroud	1 req'd
4	VTS-AK514	Pump end plate	1 req'd
*5	VTS-AK522	Gasket	1 req'd
6	VTS-AK520	Muffler box	1 req'd
*7	VTS-AK473	O-ring	2 req'd
*8	VTS-AK524	Felt	2 req'd
9	VTS-AK510	End cap	2 req'd
10	VTS-AK526	End cap assembly, 8 & 9	2 req'd
11	VTS-AK512	Rotor	1 req'd
12	VTS-AD126	Tolerance ring	1 req'd

Not Shown

* VTS1034-1K Service kit (consists of 2, 5, 7, 8) K479

Note

Should not be replaced in field

11 & 12

LUBRICATION FOR GROVE GEAR REDUCER

1. Factory Filling

The speed reducers are oil filled at the factory to the proper level for the standard mounting position. The oil level should be checked and adjusted (if necessary) prior to operation, using the oil level plug provided and while the unit is oriented in its operating position. The oil fill plug contains a vent hole to release any internal pressure build up when operating.

2. Oil Changing



WHEN CHANGING OIL FOR ANY REASON, DO NOT MIX DIFFERENT OILS IN THE REDUCER. OILS SHOULD BE COMPATIBLE WITH VITON® SEAL MATERIAL.

Therefore, when changing to a different oil, it is recommended that the housing be completely drained and thoroughly flushed with a light flushing oil prior to refilling with the appropriate lubricant. The oil level should be rechecked after a short period of operation and adjusted, if necessary.



OIL SHOULD BE CHANGED MORE OFTEN IF THE REDUCER IS USED IN A SEVERE ENVIRONMENT (i.e., DUSTY, HUMID)

A. Initial Oil Change

The oil in a new speed reducer should be changed at the end of 250 hours of operation. (30 days for 8 hours per day service, 15 days for 16 hour service, 10 days for 24 hour service.)

All standard reducers ordered from the factory are filled with lubricant to operate within a 30° to 100°F ambient temperature range.

B. Subsequent Oil Change

Under normal conditions, after the initial oil change, the oil should be changed after every 2500 hours of operation, or every six months, whichever occurs first. Under severe conditions (rapid temperature changes, moist, dirty or corrosive environment) it may be necessary to change oil at intervals of one to three months. Periodic examination of oil samples taken from the unit will help establish the appropriate interval.

C. Synthetic Oils

Synthetic lubricants can be advantageous over mineral oils in that they generally are more stable, have a longer life, and operate over a wider temperature range. These oils are appropriate for any application but are especially useful when units are subjected to low start-up temperatures or high operating temperatures. Use of synthetics can cause problems if they are not compatible with the seals or the conventional lubricants they replace.

For continuous duty at normal ambient temperatures (-10° to 105°F) we recommend the use of Mobil SHC 634 which is compatible with the standard compounded oil shipped in our product and the Viton® seal material used.

3. Overfilling or Underfilling

If a speed reducer is overfilled with oil, the energy used in churning the excessive oil can result in overheating. If this occurs, shut down the drive, remove the oil level plug and allow oil to drain until oil ceases to drain from the level hole, reinstall the oil level plug and restart the drive. If the speed reducer is underfilled, the resultant friction can cause overheating and possible damage. If this occurs, fill the speed reducer to the oil level plug hole and check the gearing for excessive wear. NOTE: Oil capacity is 1¾ pints.

4. Oil Seals

Although the speed reducer uses high quality oil seals and precision ground shafts to provide a superior seal contact surface, it is possible that circumstances beyond the speed reducer's control can cause oil seal leakage (damage during shipment of installation, etc.). when replacing a shaft oil seal, using the following suggestions will help to insure leak-free operation and long seal life.

A. When installing a new seal, cover the keyway and any other surface discontinuity with smooth tape to protect the seal lip from being damaged.

B. A sealant should be used between the O.D. of the seal and the I.D. of the bore into which the seal is installed. The seal bore should also be free of any burrs, nicks, or scratches.

C. Be sure that the seal is not cocked in the seal bore. The outer face of the seal should be flush with the surface into which it is mounted.

**VTS512-1 GROVE GEAR REDUCER
LUBRICATION AND MAINTENANCE
AFTER SERIAL No. 667**

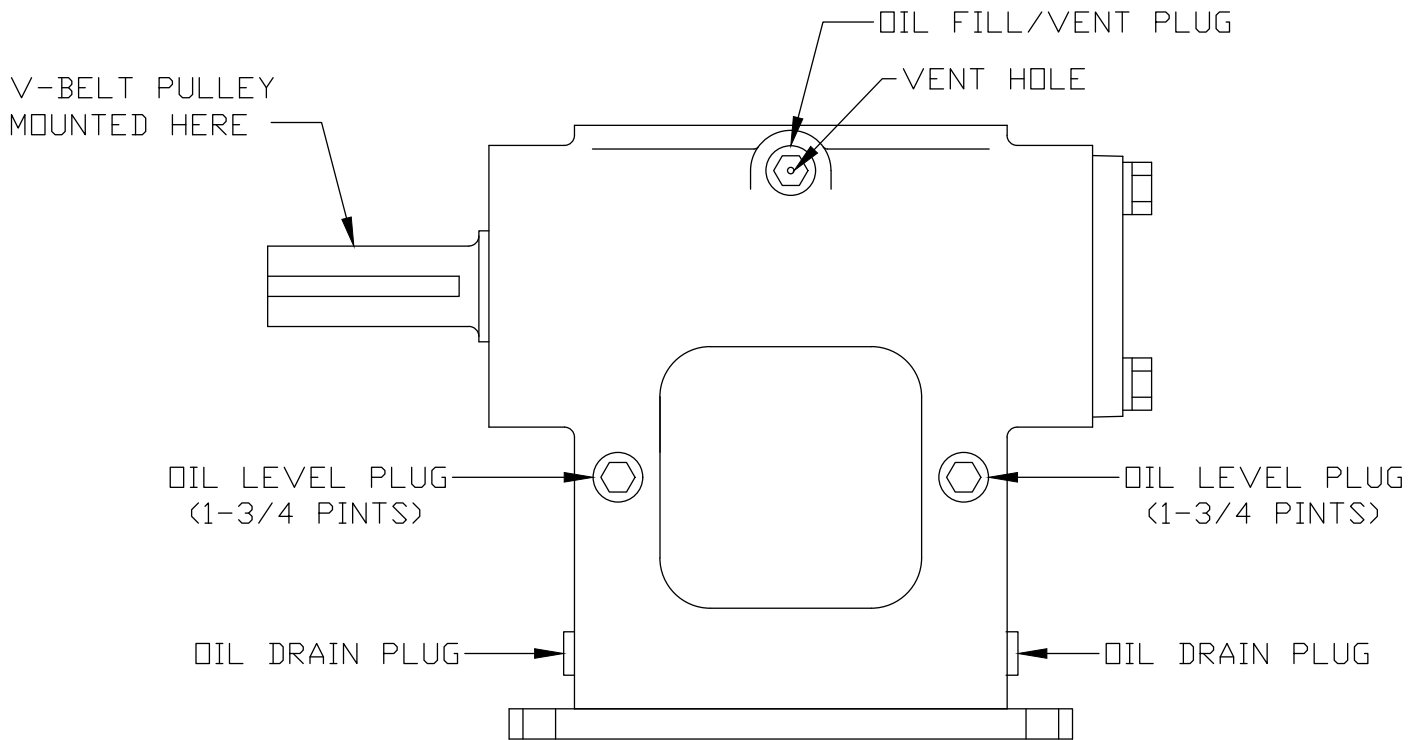

VIEW IS FROM OPPOSITE END OF DRUM

LUBRICANTS FOR VTS512-1 GROVE GEAR WORM REDUCER

The precision-made gears and bearings in Grove Gear Speed Reducers require high-grade lubricants of the proper viscosity to maintain trouble-free performance. For best results, use lubricants on the following chart for worm gear reducers.

Manufacturer	30° to 100°F Ambient Temperature AGMA Compounded No. 7	50° to 125°F Ambient Temperature AGMA Compounded No. 8
Amoco Oil Co.	Worm Gear Oil	Cylinder Oil #680
Chevron USA, Inc.	Cylinder Oil #460X	Cylinder Oil #680X
Exxon Co. USA	Cyclesstic TK-460	Cyclesstic TK-680
Gulf Oil Co.	Senate 460	Senate 680D
Mobil Oil Corp.	600 W Super Cylinder	Extra Hecla Super
Shell Oil Co.	Valvata Oil J460	Valvata Oil J680
Sun Oil Co.	Gear Oil 7C	Gear Oil 8C
Texaco	Honor Cylinder Oil	650T Cylinder Oil
Union Oil Co. of CA	Steaval A	Worm Gear Lube 140

Standard factory-installed lubricant is Mobil Oil Corp. 600 W Super Cylinder Oil (AGMA7).

Some gear lubricants contain E.P. additives that can be corrosive to gear bronze material. Avoid lubricants that are compounded with sulfur and/or chlorine.

TO PROGRAM ITEM No. VTS511 EAGLE SIGNAL TIMER

Key Sequence

Press **SET** Key

Press **SET** Key

Change using Arrow Keys

Press **ENT** Key

Press **SET** Key

Press **SET** Key

Change using Arrow Keys

Press **ENT** Key

Press **SET** Key

Press **SET** Key

Change using Arrow Keys

Press **ENT** Key

Press **ENT** Key

Display

SEt1 prompt is displayed.

Setpoint 1 (tumble time) is displayed with flashing digit indicating that setpoint can be changed.

New setpoint value is displayed.

New setpoint entered into memory.

SEt2 prompt is displayed.

Setpoint 2 (relax time) is displayed with flashing digit indicating that setpoint can be changed.

New setpoint value is displayed.

New setpoint entered into memory.

REPt prompt is displayed.

Cycle repeat is displayed with flashing digit indicating that setpoint can be changed.

New setpoint value is displayed.

New setpoint entered into memory.

Press **RST** key.

Timing cycle is entered into memory.

NOTE: The **ENT** Key must be pressed after any variable data has been entered.

EXAMPLE SETTINGS:

Tumble for 15 minutes

Relax for 10 minutes

Repeat 3 times

Total Tumble Time for 45 minutes

Total Relax Time for 30 minutes

SEt1 = 15.00

SEt2 = 10.00

REPt = 0003

Tumble for 45 minutes

No relax time

Repeat 1 time

Total Tumble Time for 45 minutes

SEt1 = 45.00

SEt2 = 00.00

REPt = 0001

**TO PROGRAM ITEM No. VTS626 RED LION MODEL PAXTM TIMER
STARTING WITH SERIAL No. 782**

THE FOLLOWING PROCEDURE EXPLAINS HOW TO PROGRAM
THE RED LION MODEL PAXTM TIMER USING THE FRONT BUTTONS LOCATED ON THE TIMER.
FIRST, REVIEW THE FRONT BUTTONS AND DISPLAY READOUTS:

<u>BUTTON</u>	<u>DESCRIPTION</u>
(DSP)	DISPLAYS THE TIME OR THE COUNT. THERE ARE 2 READOUT LEGENDS LOCATED ON THE LEFT SIDE OF THE DISPLAY. TMR, DISPLAYS THE TIME CNT, DISPLAYS THE COUNT THE DSP BUTTON TOGGLES BETWEEN TIME AND COUNT
(PAR)	ACCESSES THE PROGRAMMING MODE. THIS ALLOWS THE USER TO CHANGE THE TIMES AND COUNT.
(F1, ARROW UP)	INCREASES TIME AND COUNT
(F2, ARROW DOWN)	DECREASES TIME AND COUNT
(RST)	WHEN IN PROGRAMMING MODE, THIS BUTTON MOVES THE POSITION OF THE FLASHING DIGIT, RIGHT TO LEFT

FRONT BUTTONS AND DISPLAY

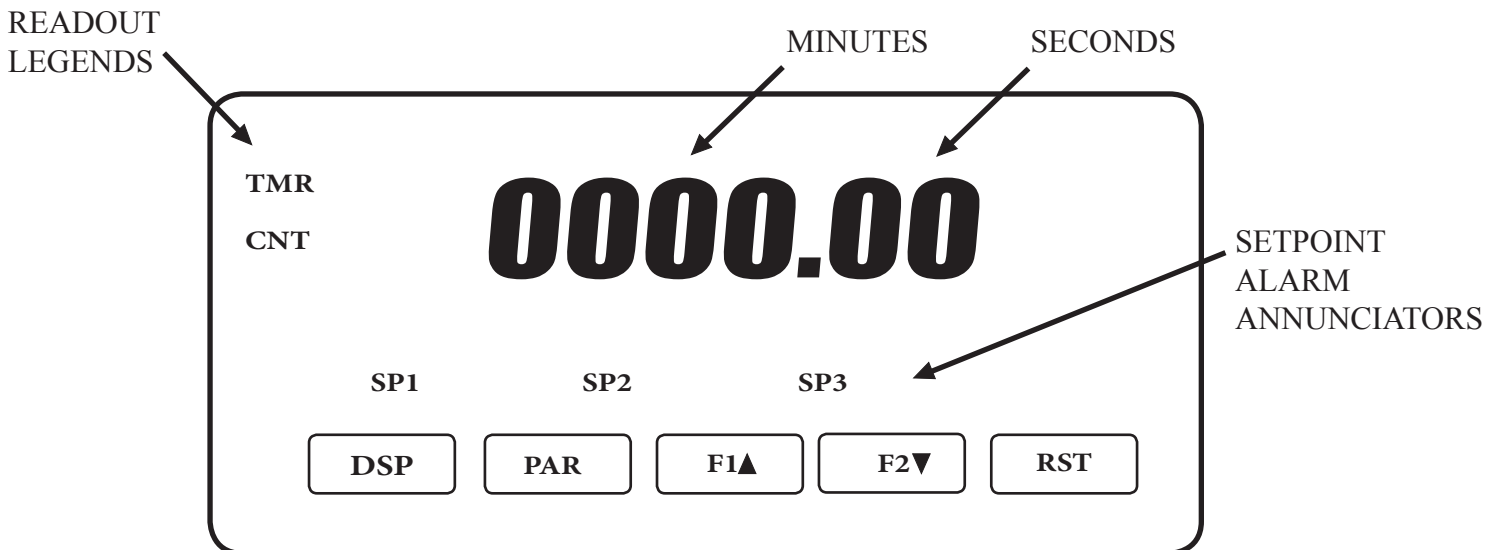

(continued on next page)

PROGRAMMING THE TIMER FOR REPEAT CYCLE OPERATION (RUN-RELAX-REPEAT-RESET).

1. Press **(PAR)** button.
2. Display will show “SPOF-1” and a time (RUN TIME). The two screens will alternate on and off.
3. Enter a time by PRESSING **(F1)** button to increase time, or PRESS **(F2)** button to decrease time.
4. Press **(PAR)** button. Time is entered into the program.
5. Display screen will show “SPOF-2” and a time (RELAX TIME). The two screens will alternate on and off.
6. Enter a time (see No. 3) and press **(PAR)** button. Time is now entered into the program.

NOTE: “SPOF-2” (RELAX TIME) IS ACCUMULATIVE TO THE “SPOF-1” (RUN TIME) SO IT MUST BE ADDED TO OR ENTERED GREATER THAN THE “SPOF-1” (RUN TIME).

EXAMPLE: *RUN TIME IS 10 SEC., RELAX TIME IS 10 SEC.
ENTER “SPOF-1” TIME AS 10 SEC., ENTER SPOF-2” TIME AS 20 SEC.*

7. Display will show “SP-3” and a count (REPEAT OR CYCLE COUNT). The two screens will alternate on and off.
8. Enter a count and press **(PAR)** button. Count is entered into the program.
9. Display will show “END” then automatically switches to 0.00.
10. Timer is in the ready state. Press **GREEN ON** button to run the machine.

THE TIMER WILL AUTOMATICALLY RESET AFTER TIMING IS COMPLETE.

(continued on next page)

PROGRAMMING THE TIMER FOR A CONTINUOUS OPERATION.

NOTE:

TO STOP CONTINUOUS OPERATION, E-STOP BUTTON MUST BE PRESSED.

1. Press **(PAR)** button.
2. Display will show “SPOF-1” and a time (RUN TIME). The two screens will alternate on and off.
3. Enter a time by PRESSING **(F1)** button to increase time, or PRESS **(F2)** button to decrease time.
4. Enter 0 as a time and press **(PAR)** button. Time is entered into the program.
5. Display screen will show “SPOF-2” and a time (RELAX TIME). The two screens will alternate on and off.
6. Enter 0 as a time and press **(PAR)** button. Time is entered into the program.
7. Display will show “SP-3” and a count (REPEAT OR CYCLE COUNT). The two screens will alternate on and off.
8. Enter 0 for a count and press **(PAR)** button. Count is entered into the program.
9. Display will show “END” then automatically switches to 0.00.
10. The timer is now in a ready state. Press **GREEN ON** button to start the machine.

THE TIMER WILL RUN CONTINUOUS UNTIL THE E-STOP BUTTON IS PRESSED, POWER IS TURNED OFF, OR THE PHOTO-EYE SENSES AN OBJECT. TIMER WILL RESET WHEN POWER IS TURNED ON.

(continued on next page)

PROGRAMMING THE TIMER FOR A RUN-STOP-RESET OPERATION.

1. Press **(PAR)** button.
2. Display will show “SPOF-1” and a time (RUN TIME). The two screens will alternate on and off.
3. Enter a time by PRESSING **(F1)** button to increase time, or PRESS **(F2)** button to decrease time.
4. Press **(PAR)** button. Time is entered into the program.
5. Display screen will show “SPOF-2” and a time (RELAX TIME). The two screens will alternate on and off.
6. Enter the same time as “SPOF-1” and press **(PAR)** button. Time is now entered into the program.
7. Display will show “SP-3” and a count (REPEAT OR CYCLE COUNT). The two screens will alternate on and off.
8. Enter 1 for a count and press **(PAR)** button. Count is entered into the program.
9. Display will show “END” then automatically switches to 0.00.
10. The timer is now in a ready state. Press **GREEN ON** button to start the machine.

THE TIMER WILL AUTOMATICALLY RESET AFTER TIMING CYCLE IS COMPLETE.

CAUTION: “If” SPOF-2 time is LESS than SPOF-1 time, the machine will run non-stop, until the E-STOP button is pressed, power is turned off, or the safety photo eye senses an object.

“If” SP-3 count is set to 0, the timer will cycle on and off, non-stop, until the E-stop button is pressed, power is turned off, or the photo-eye senses an object.
The timer will reset after timer is turned on.

TIMER PROGRAM NOTES

ITEM No. VTS1053
PHOTOELECTRIC PROXIMITY SWITCH
OPERATING INSTRUCTIONS

A photoelectric (electric eye) switch is mounted behind a clear cover inside the motor component. This photoelectric switch is an optical-electronic sensor and is used for non-contact detection of objects or persons.

When this switch detects an interference, (object or person) the machine will not operate (or cease operation) until the interference is cleared from the detection area.

This photoelectric proximity switch has a sensitivity adjustment that is adjusted to MAXIMUM sensitivity when the tumbler is shipped from the factory. The sensitivity may need to be adjusted depending on light intensity and surrounding area where the machine is located.

When the photoelectric switch is detecting an interference, an led light located on top of the switch will illuminate. When the interference is removed from the detection area, the led light will turn off (See Figure 1).

TO ADJUST THE SENSITIVITY:

Remove the top cover from switch using a small screwdriver (See Figure 2).

Rotate the yellow sensitivity knob (See Figure 3) counterclockwise to reduce sensitivity, (270 degrees turning range, maximum to minimum). Sensitivity will vary due to ambient light intensity and surrounding area. Re-install top cover after adjustment is made.

MAINTENANCE:

Photoelectric switches do not require any maintenance.

Be sure the optical window is kept clean. Also check mounting fasteners and wire connections at regular intervals.

NOTE:

The switch is mounted to a bracket which is purposefully aimed 15 degrees outward, to project the light beam at a slight angle away from the rotating drum (See Figure 4).

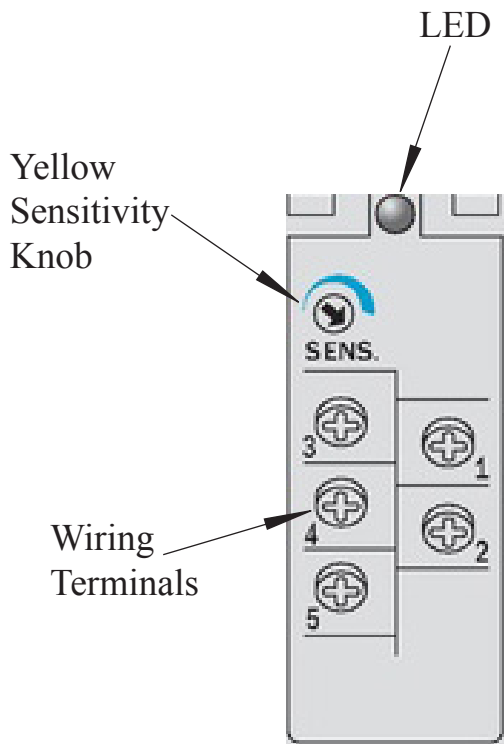
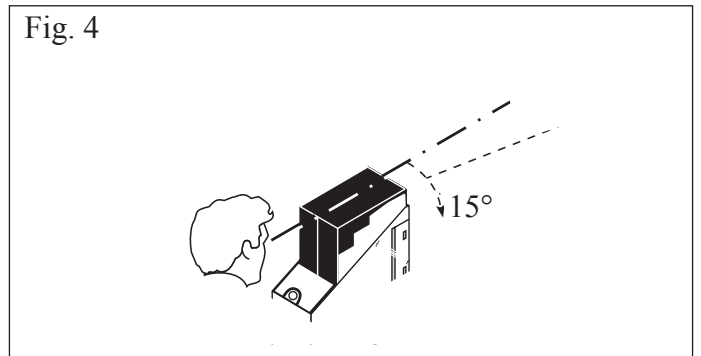
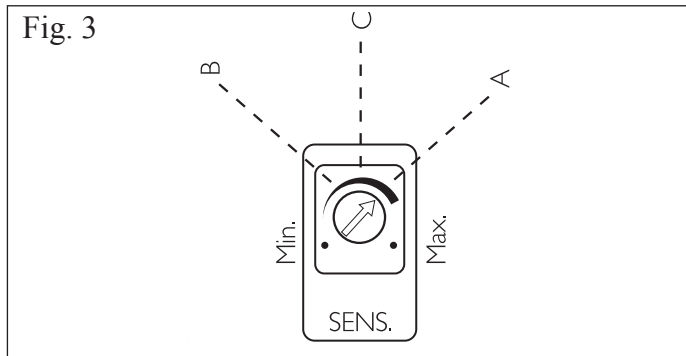
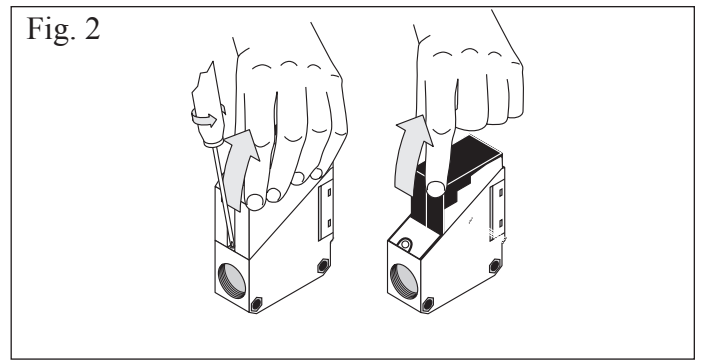
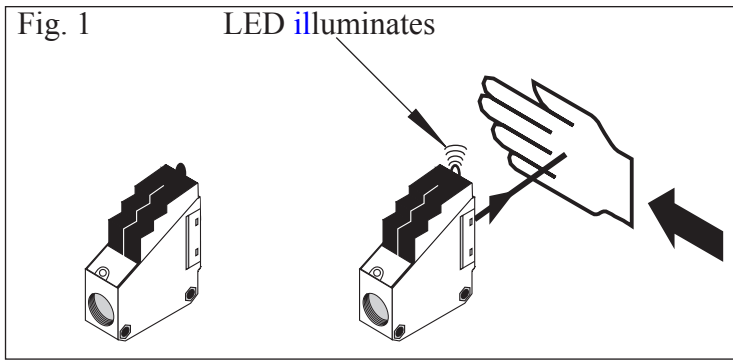

Wiring Diagram

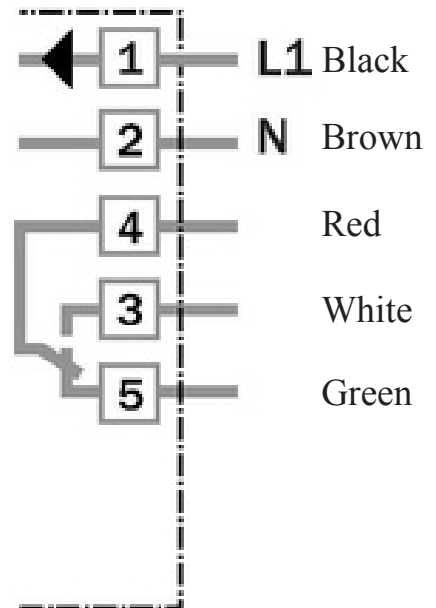

CONTROL PANEL COMPONENTS

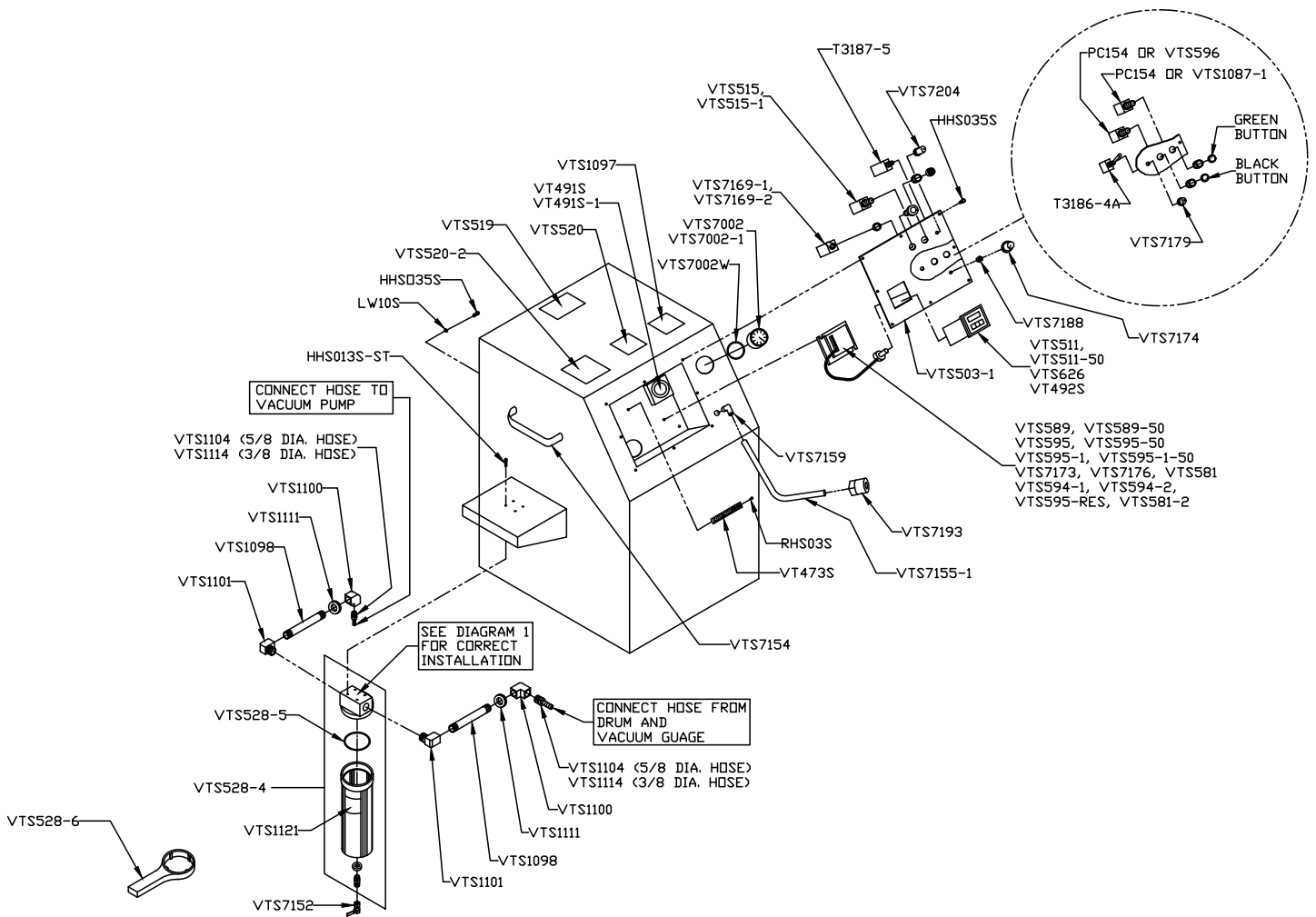

Item No.	Description
HHS013S-ST	Hex head screw, 10-16 x 3/4" self tap, SS
HHS035S	Hex head screw, 1/4-20 x 5/8", SS
LW10S	Lock washer, 1/4", SS
PC154	Jog/On Switch w/ buttons, black & green
RHS03S	Round head screw, 6-32 x 3/4", SS
T3186-4A	Toggle switch w/ cap nut, 115V
T3187-5	Circuit breaker - 15 Amp
VT473S	Terminal strip - 12 circuit
VT491S	Ventilation fan, 120V, use VT491SK
VT491S-1	Ventilation fan, 220V
VT492S	Timer, 0-50 minutes, Interval mode
VTS503-1	Control panel, Red Lion Timer
VTS515	Timer indicator light - 120V
VTS515-1	Timer indicator light - 230V
VTS520	Label, Drum Warning
VTS520-2	Label, Filter Drain
VTS528-4	External trap, clear bowl
VTS528-5	O-ring, external trap
VTS528-6	Wrench, external trap
VTS589	Power supply, 120VAC-90VDC-.015Res.
VTS589-50	Power supply, 220VAC-90VDC-.015Res.
VTS626	Red lion timer, starting w/ s/n 782
VTS628	Label, Required Minimum Distance
VTS1097	Label, Caution Vacuum Draw

Item No.	Description
VTS1098	Nipple, 6 x 1/2" NPT - brass
VTS1100	Elbow, 90 deg. x 1/2" NPT - brass
VTS1101	Street elbow, 90 deg. x 1/2" NPT - brass
VTS1104	Male hose barb, 5/8 x 1/2" NPT - brass
VTS1111	Grommet, 7/8 I.D.
VTS1114	Male hose barb, 3/8 x 1/2" NPT - brass
VTS1121	Label, External Water Trap
VTS7002	Vacuum gauge
VTS7002-1	Vacuum gauge clamp kit
VTS7002W	Vacuum gauge washer
VTS7132	Aluminum washer
VTS7152	Ball valve, SS
VTS7154	Handle
VTS7155-1	Hose with 3/8" crimped fittings
VTS7159	Elbow, 90 deg. 3/8 x 3/8" FPT - SS
VTS7169-1	E-stop switch - 120VAC
VTS7169-2	E-stop switch - 240VAC
VTS7173	Potentiometer & 12" cable
VTS7174	Knob, potentiometer
VTS7179	Toggle switch half boot
VTS7188	Potentiometer boot
VTS7193	Quick coupling, SS
VTS7204	Boot, circuit breaker
VTS7213	Bulb, 120V - 60Hz

CONTROL PANEL - REAR VIEW

TUMBLERS WITH RED LION TIMER & TIME INHIBIT FORWARD ROTATION ONLY

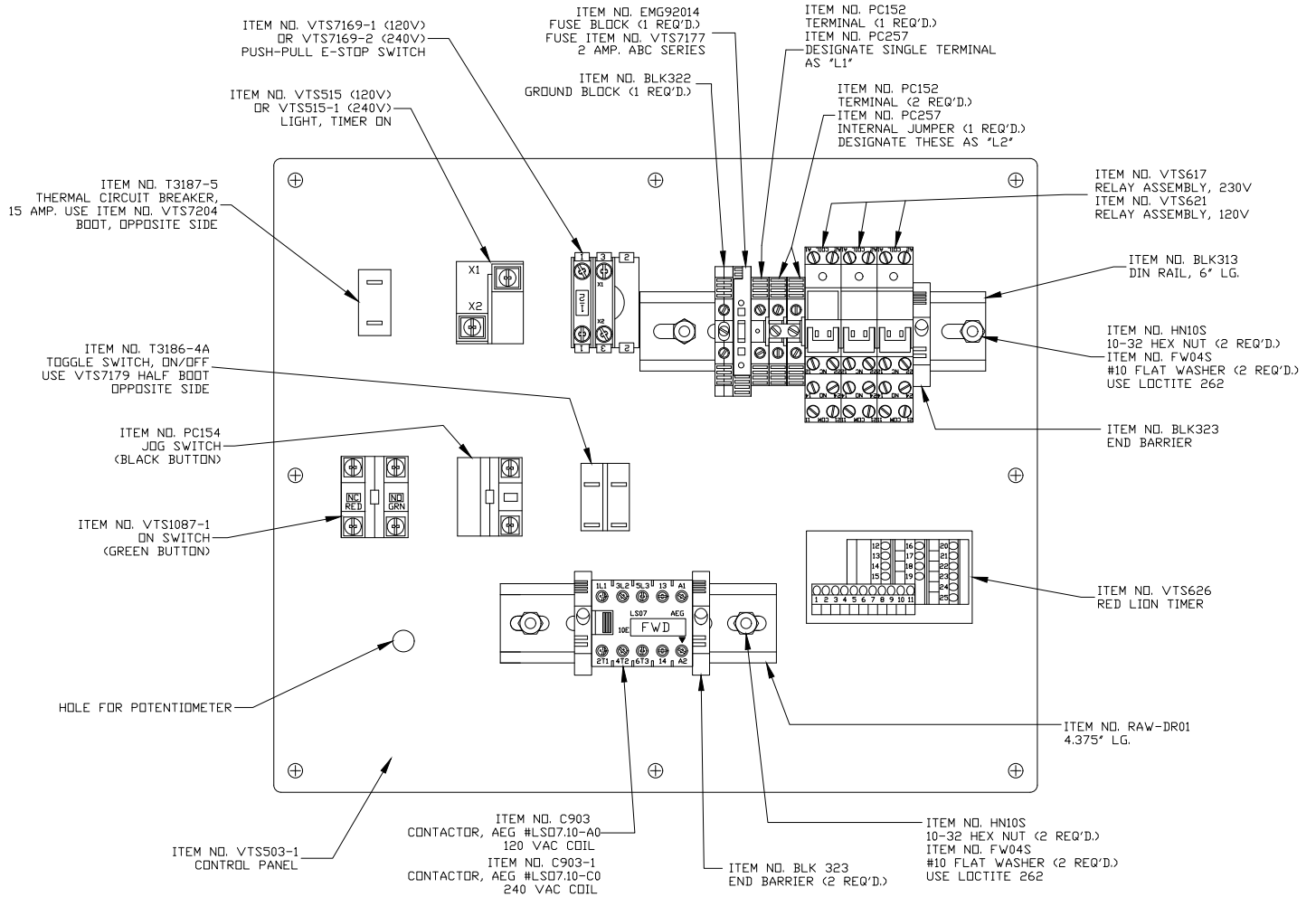

CONTROL PANEL - REAR VIEW

TUMBLERS WITH RED LION TIMER & TIME INHIBIT FORWARD ROTATION W/ REVERSE JOG

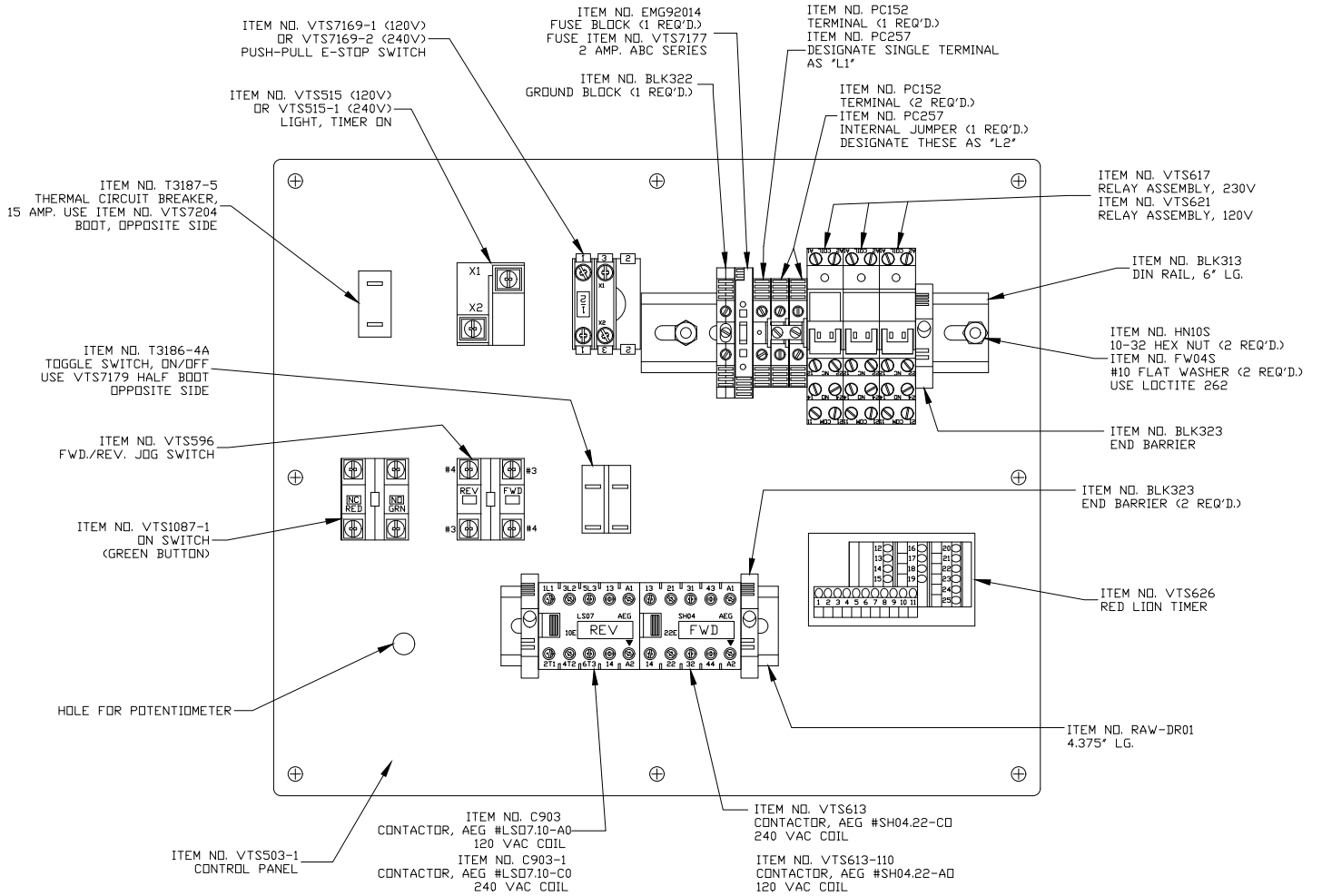

CONTROL PANEL - REAR VIEW

TUMBLERS WITH INTERVAL TIMER FORWARD ROTATION ONLY

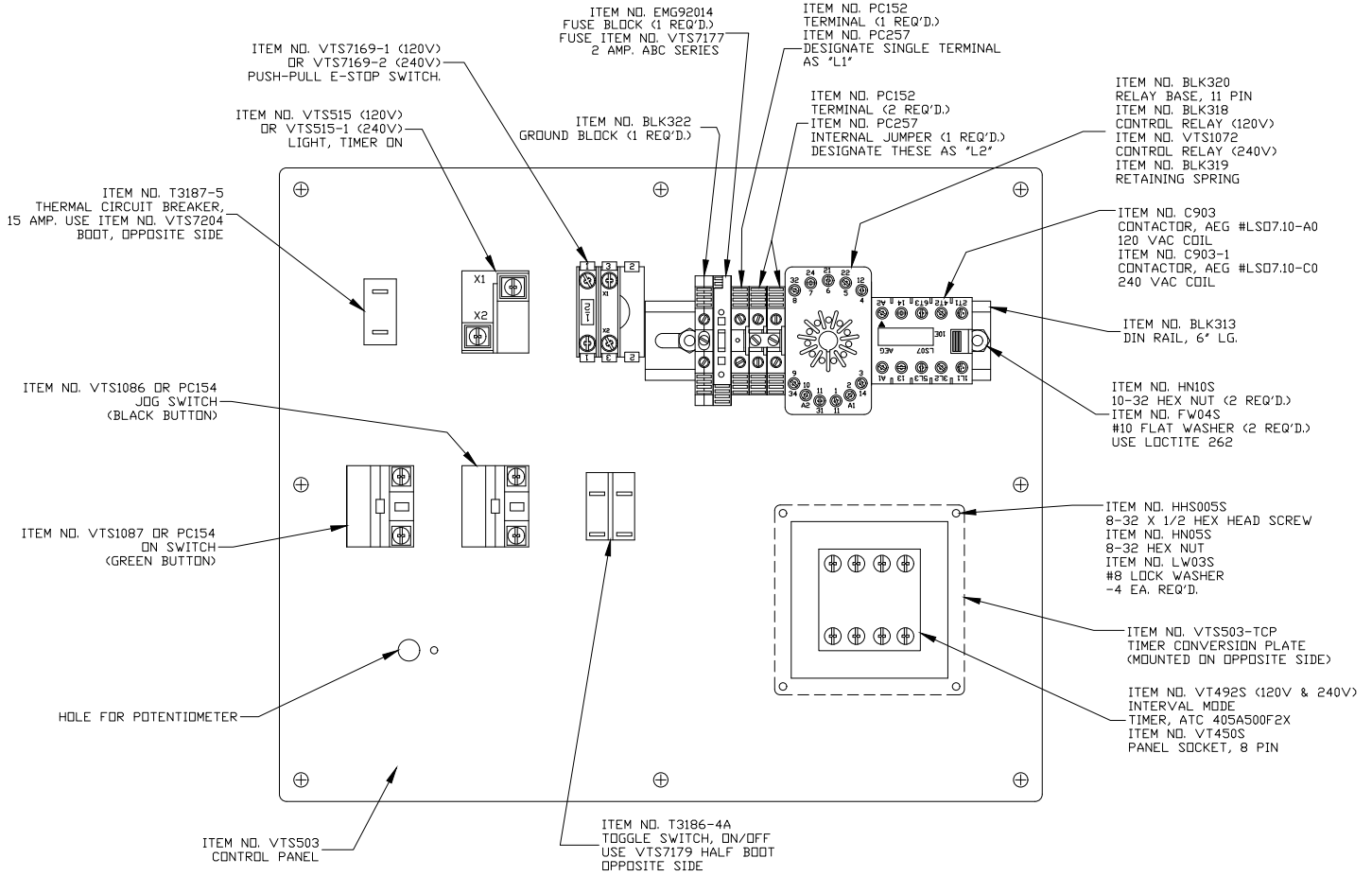

DRUM ASSEMBLY STARTING WITH SERIAL 602

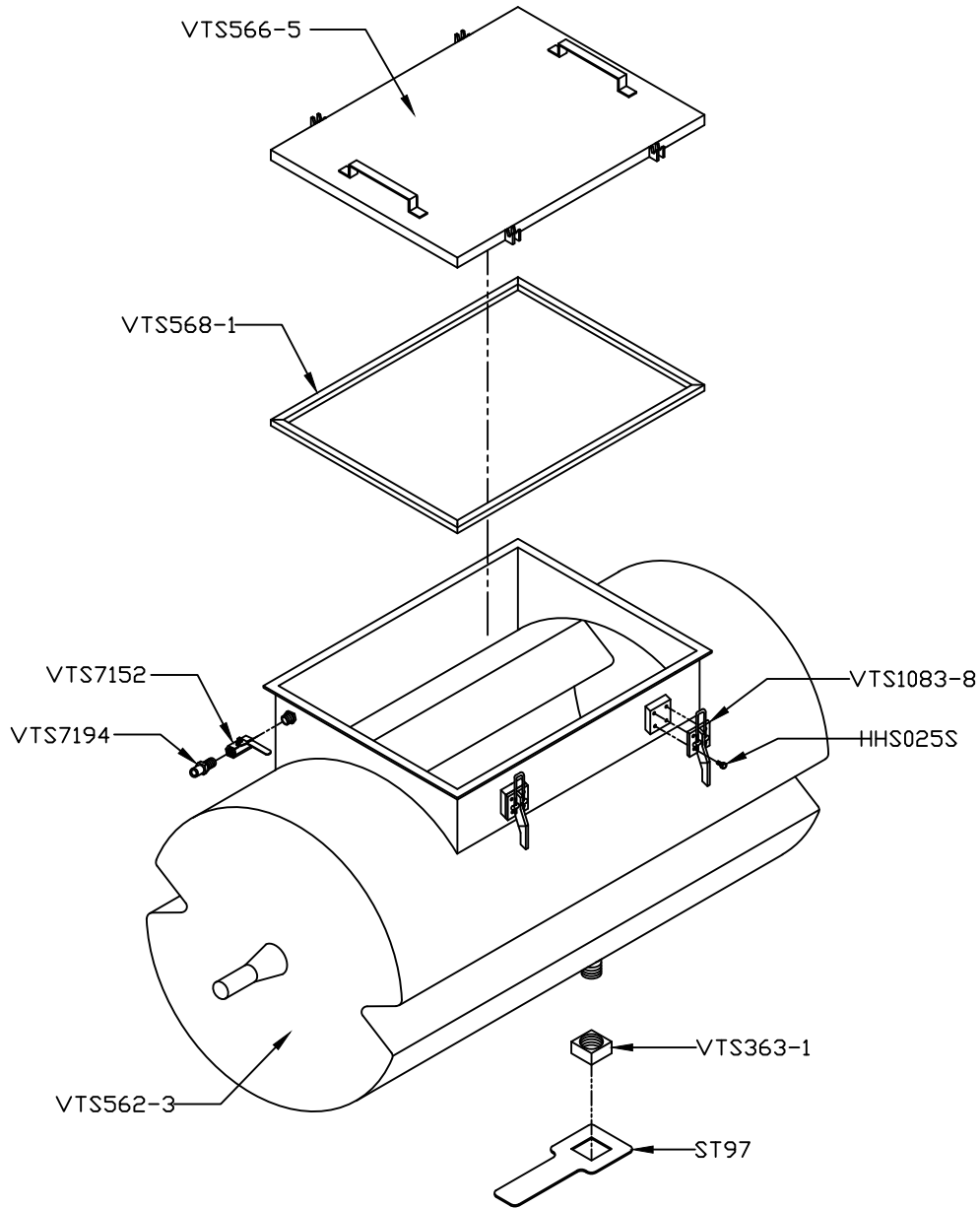

Item No.	Description
HHS025S	Hex head screw, 1/4-20 x 1/2", SS
ST97	Drain cap wrench
VTS363-1	Drain cap
VTS562-3	Drum weldment
VTS566-5	Drum cover
VTS568-1	Drum cover gasket
VTS1083-8	Lid latch
VTS7152	Ball valve, SS
VTS7194	Quick coupling, SS

FRAME ASSEMBLY AND COMPONENTS

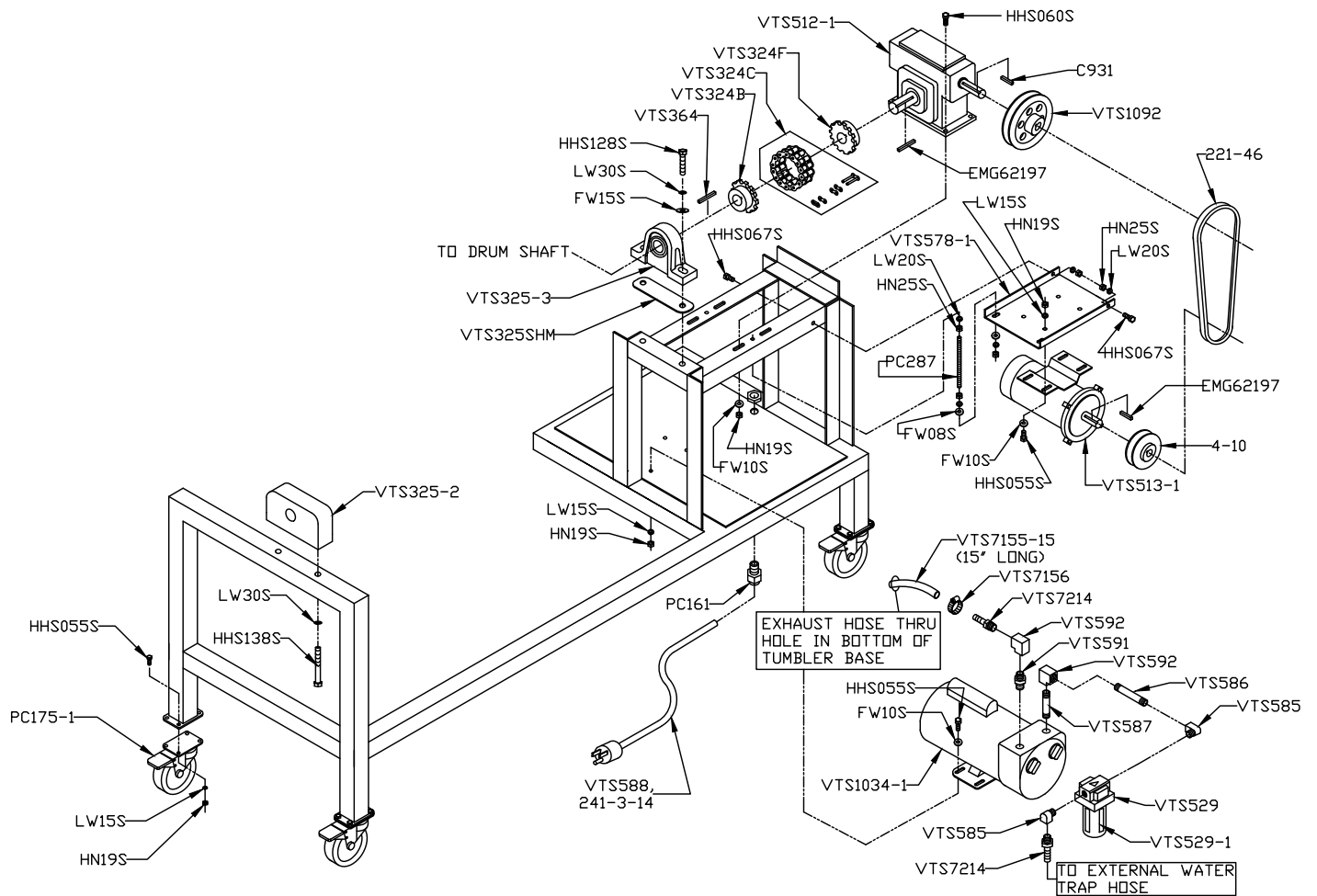

Item No.	Description
4-10	Motor pulley, 4 x 5/8 bore
221-46	V-belt, 46 inch starting w/ s/n 666
C931	Key, 3/16 x 3/16 x 1 3/8 long
EMG62197	Key, 1/4 x 1/4 x 2 1/4 long
FW08S	Flat washer, 3/8, SS
FW10S	Flat washer, 5/16, SS
FW15S	Flat washer, 1/2, SS
HHS055S	Hex head screw, 5/16-18 x 3/4, SS
HHS060S	Hex head screw, 5/16-18 x 1, SS
HHS067S	Hex head screw, 3/8-16 x 3/4, SS
HHS128S	Hex head screw, 1/2-13 x 1 3/4, SS
HHS138S	Hex head screw, 1/2-13 x 4, SS
HN19S	Hex nut, 5/16-18, SS
HN25S	Hex nut, 3/8-16, SS
HN43S	Hex nut, 1/2-13, SS
LW15S	Lock washer, 5/16, SS
LW20S	Lock washer, 3/8, SS
LW30S	Lock washer, 1/2, SS
PC161	Strain relief fitting, 7/8 dia.
PC175-1	Caster with total lock swivel
PC287	Motor adjustment threaded rod
VTS324-1	Coupling assembly, up to s/n: 666
VTS324-2	Coupling assembly, starting w/ s/n: 667

Item No.	Description
VTS324B	Roller chain coupling hub, 1 1/2 bore
VTS324C	Chain assembly
VTS324F	Roller chain coupling hub, 1 1/8 bore
VTS325-2	Pillow block - Delrin
VTS325-3	Pillow block bearing
VTS325SHM	Pillow block shim
VTS364	Key, drum shaft
VTS512-1	Grove gear reducer, 60:1 starting w/ s/n 667
VTS513-1	Gear motor 90VDC x 3/4HP
VTS529	Vacuum pump filter
VTS529-1	Filter element
VTS578-1	Motor base plate, adj. starting w/ s/n 667
VTS585	Elbow, 90 deg. Street, 3/8" - brass
VTS586	Nipple, 3 inch, 3/8 pipe brass
VTS587	Nipple, 2 inch, 3/8 pipe brass
VTS588	Power cord, 14-3 sjow, 12 ft w/ plug
VTS591	Nipple, 1 3/8 inch, 3/8 pipe brass
VTS592	Elbow, 90 deg. 3/8" - brass
VTS1034-1	Vacuum pump - 3/4HP
VTS1092	Pulley, 9 x 3/4 bore, al. starting w/ s/n 667
VTS7155-15	Vacuum hose, 15 inch
VTS7156	Hose clamp, SS
VTS7214	Hose barb, 3/8 MPT x 3/8 x .95 long brass

VACUUM HOSES AND FITTINGS

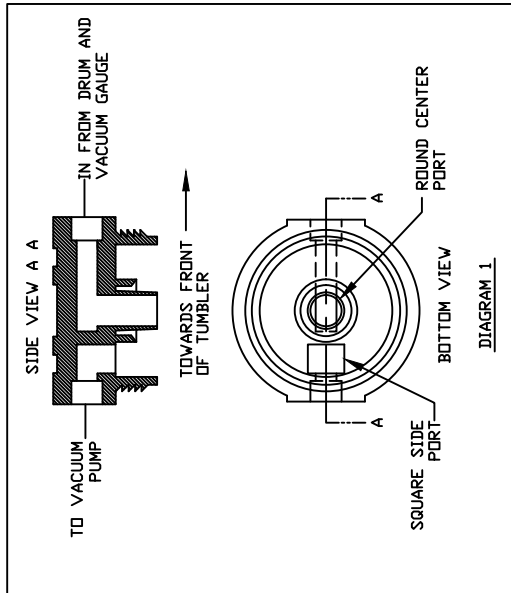
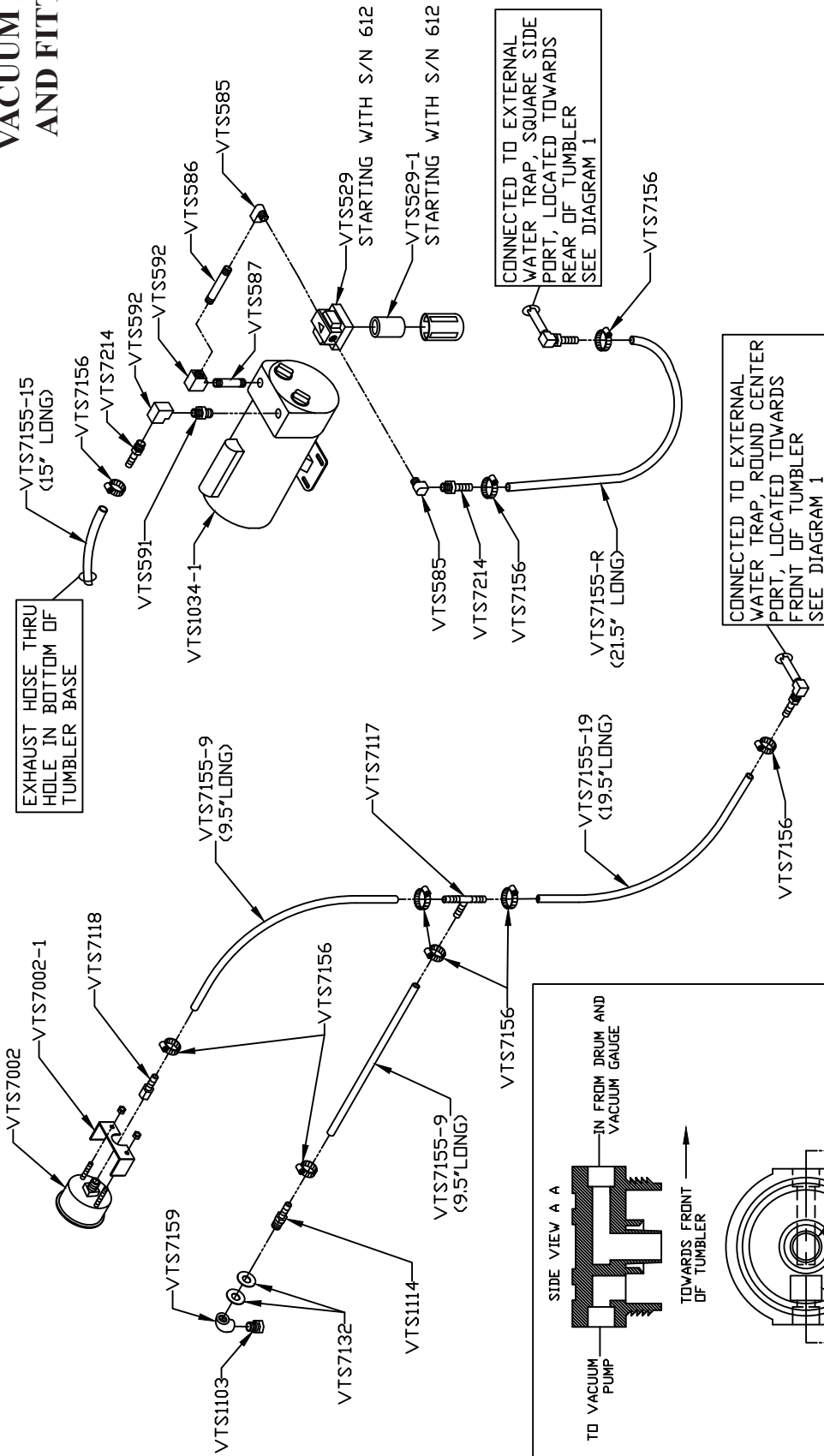

Item No.	Description
VTS529	Vacuum pump filter
VTS529-1	Filter element
VTS585	Elbow, 90 deg. street, 3/8" - brass
VTS586	Nipple, 3 inch, 3/8 pipe brass
VTS587	Nipple, 2 inch, 3/8 pipe brass
VTS591	Nipple, 1 3/8 inch, 3/8 pipe brass
VTS592	Elbow, 90 deg. 3/8" - brass
VTS1034-1	Vacuum pump - 3/4HP
VTS1103	Reducer bushing 1/2 x 3/8, SS
VTS1114	Male hose barb, 3/8 x 1/2" NPT - brass
VTS7002	Vacuum gauge
VTS7117	Tee barb, 3/8 x 3/8 x 3/8, plastic
VTS7118	Straight barb, 1/4 FPT x 3/8, brass
VTS7132	Aluminum washer
VTS7155-9	Vacuum hose, 9 1/2 inch Nylobrade
VTS7155-15	Vacuum hose, 15 inch Nylobrade
VTS7155-19	Vacuum hose, 19 1/2 inch Nylobrade
VTS7156	Hose clamp
VTS7159	Elbow, 90 deg. 3/8 x 3/8" FPT - SS
VTS7214	Hose barb, 3/8 MPT x 3/8 x .95 long brass

COMPONENT COVER AND REAR DOOR

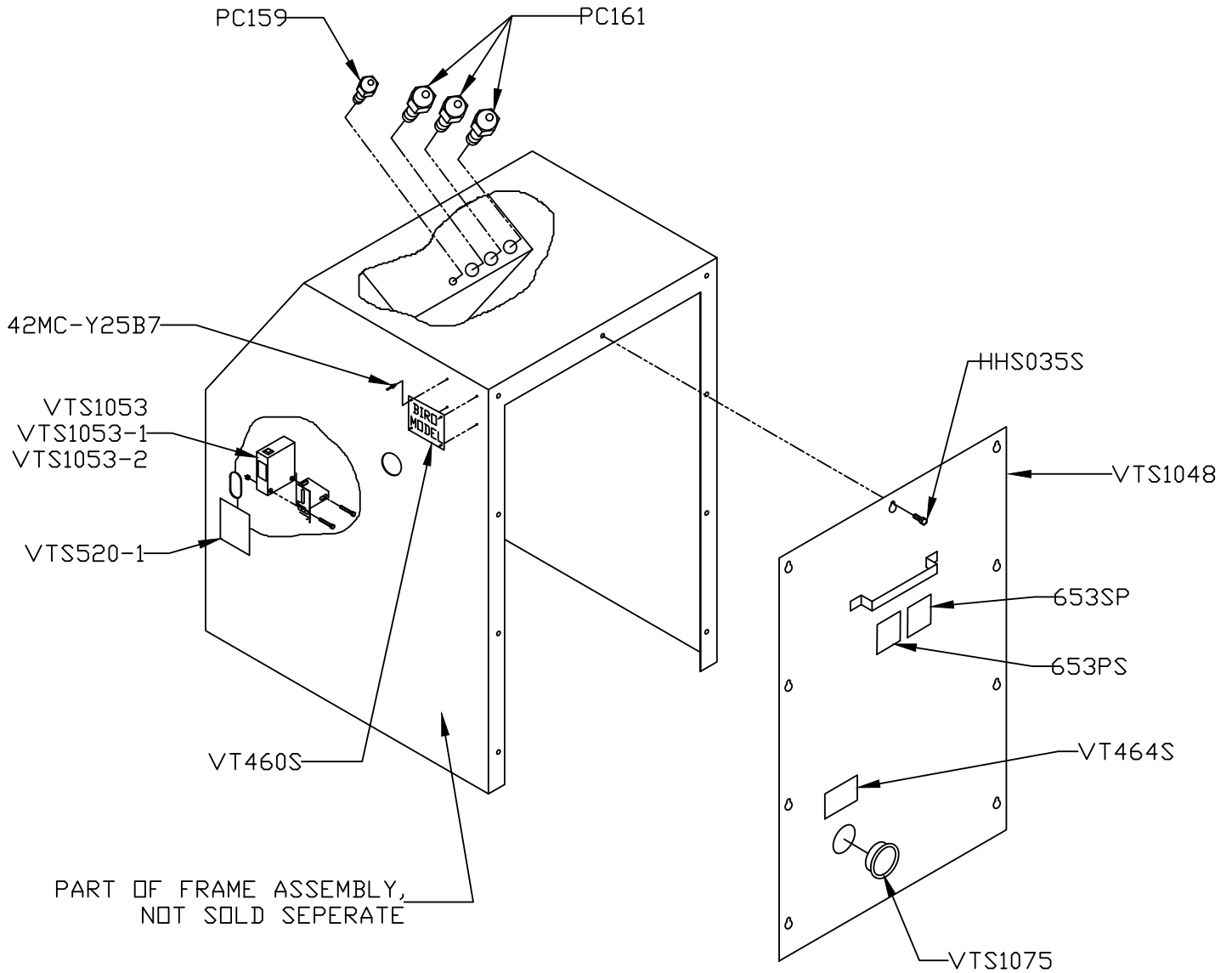

Item No.	Description
42MC-Y25B7	Pop rivet
653PS	Warning Label, English
653SP	Warning Label, Spanish
HHS035S	Hex head screw, 1/4-20 x 5/8, SS
PC159	Strain relief fitting, 1/2 dia.
PC161	Strain relief fitting, 7/8 dia.
VT460S	Model & S/N plate, Serial # req'd
VT464S	Filter label
VTS520-1	Label, Photo Sensor Notice
VTS1048	Rear door
VTS1053	Photoelectric eye w/ bracket only
VTS1053-1	Photoelectric eye assembly - 4 wires used w/ VT492S timer only
VTS1053-2	Photoelectric eye assembly - 5 wires
VTS1075	Sight window - 2" dia.

PREVENTATIVE MAINTENANCE

General: Vacuum Components, Electrical Components:

Check drum cover gasket for cuts, tears, damage. Replace if damaged.

Install gasket and lid onto vacuum drum.

Check for proper fit and correct latch tension to achieve good seal. Adjust latch if needed.

Check electrical components for damage.

Remove power from machine. Replace damaged components.

Check power cord for wear or damage.

Remove cord from power source. Replace power cord.

Check photoelectric eye switch for proper operation.

Machine must stop when eye is activated.

Do not use machine if photoelectric eye switch does not work correctly.

Repair or replace.

Check external water trap for liquid/marinade.

If liquid is above maximum level, inspect complete vacuum system and the vacuum pump.

Disassemble, clean, and dry all components including vacuum pump.

Reassemble.

Check vacuum hoses and fittings for wear or damage. Replace if damaged.

Vacuum Pump Caution: During operation, water/marinade must not enter vacuum pump. Immediately clean and dry all vacuum components.

Lubrication: Motor, Vacuum Pump, Drum Bearings, Chain Coupling, Gear Reducer:

The drive motor has sealed bearings. There is no need to re-lubricate.

The vacuum pump motor has sealed bearings. There is no need to re-lubricate.

The vacuum pump has carbon vanes and does not require lubrication.

CAUTION: PUMP MUST NOT INGEST ANY WATER OR MARINADE.

The drum bearing should be greased every 40 hours.

The chain coupling should be greased every 160 hours.

Grease Manufacturer: SHELL

Grease Type: CASSIDA EPS 2 or Equivalent.

The gear reducer oil should be changed at the end of 250 hours.

Subsequent oil changes should be done every 2500 hours or 6 months, whichever comes first.

Oil Manufacturer: MOBIL OIL CORP.

Oil Type: 600W SUPER CYLINDER OIL or Equivalent.

Oil Capacity: 1³/₄ Ounces.

WIRING DIAGRAM

120/240 VAC 50/60HZ. 1PH.
RED LION TIMER WITH TIME INHIBIT
FORWARD ROTATION ONLY
DART MOTOR SPEED CONTROLLER

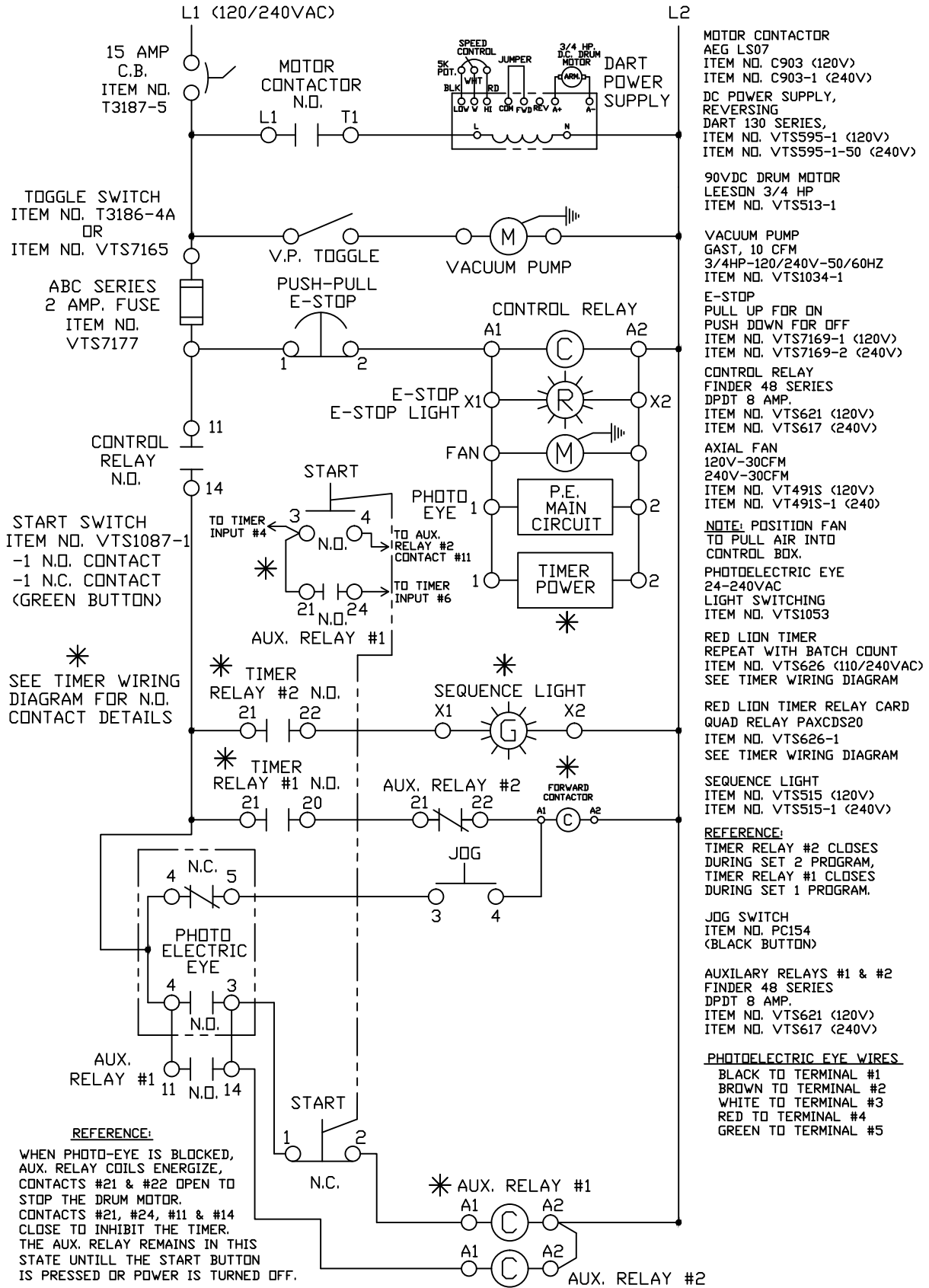

WIRING DIAGRAM

120/240 VAC 50/60HZ, 1PH.
 RED LION TIMER WITH TIME INHIBIT
 FORWARD ROTATION WITH REVERSE JOG
 DART MOTOR SPEED CONTROLLER

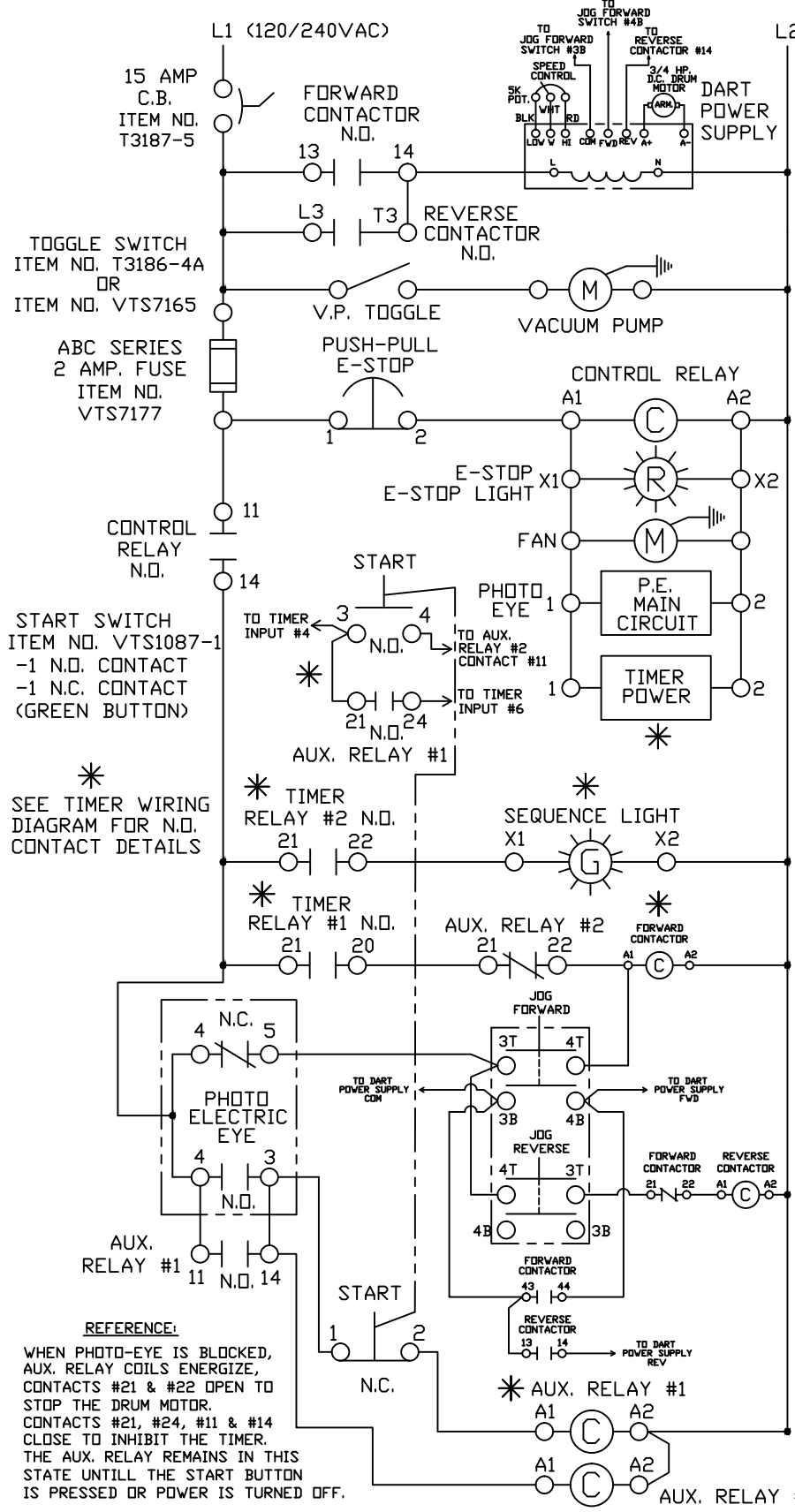

- FORWARD CONTACTOR
AEG SHD4.22
ITEM NO. VTS613-120 (120V)
ITEM NO. VTS613 (240V)
- REVERSE CONTACTOR
AEG LS07.10
ITEM NO. C903 (120V)
ITEM NO. C903-1 (240V)
- DC POWER SUPPLY,
REVERSING
DART 130 SERIES,
ITEM NO. VTS595-1 (120V)
ITEM NO. VTS595-1-50 (240V)
- 90VDC DRUM MOTOR
LEESON 3/4 HP
ITEM NO. VTS513-1
- VACUUM PUMP
GAST, 10 CFM
3/4HP-120/240V-50/60HZ
ITEM NO. VTS1034-1
- E-STOP
PULL UP FOR ON
PUSH DOWN FOR OFF
ITEM NO. VTS7169-1 (120V)
ITEM NO. VTS7169-2 (240V)
- CONTROL RELAY
FINDER 48 SERIES
DPDT 8 AMP.
ITEM NO. VTS621 (120V)
ITEM NO. VTS617 (240V)
- AXIAL FAN
120V-30CFM
240V-30CFM
ITEM NO. VT491S (120V)
ITEM NO. VT491S-1 (240V)
- NOTE: POSITION FAN
TO PULL AIR INTO
CONTROL BOX.
- PHOTOELECTRIC EYE
24-240VAC
LIGHT SWITCHING
ITEM NO. VTS1053
- RED LION TIMER
REPEAT WITH BATCH COUNT
ITEM NO. VTS626 (110/240VAC)
SEE TIMER WIRING DIAGRAM
- RED LION TIMER RELAY CARD
QUAD RELAY PAXCDS20
ITEM NO. VTS626-1
SEE TIMER WIRING DIAGRAM
- SEQUENCE LIGHT
ITEM NO. VTS515 (120V)
ITEM NO. VTS515-1 (240V)
- REFERENCE:
TIMER RELAY #2 CLOSES
DURING SET 2 PROGRAM,
TIMER RELAY #1 CLOSES
DURING SET 1 PROGRAM.
- JOG SWITCH
FORWARD/REVERSE
3 POSITION SELECTOR
ITEM NO. VTS596
(3T & 4T = TOP CONTACTS)
(3B & 4B = BOTTOM CONTACTS)
- AUXILIARY RELAYS #1 & #2
FINDER 48 SERIES
DPDT 8 AMP.
ITEM NO. VTS621 (120V)
ITEM NO. VTS617 (240V)
- PHOTOELECTRIC EYE WIRES
BLACK TO TERMINAL #1
BROWN TO TERMINAL #2
WHITE TO TERMINAL #3
RED TO TERMINAL #4
GREEN TO TERMINAL #5

REFERENCE:
 WHEN PHOTO-EYE IS BLOCKED,
 AUX. RELAY COILS ENERGIZE,
 CONTACTS #21 & #22 OPEN TO
 STOP THE DRUM MOTOR.
 CONTACTS #21, #24, #11 & #14
 CLOSE TO INHIBIT THE TIMER.
 THE AUX. RELAY REMAINS IN THIS
 STATE UNTILL THE START BUTTON
 IS PRESSED OR POWER IS TURNED OFF.

TIMER WIRING DIAGRAM

RED LION MODEL PAXTM TIMER W/
QUAD RELAY #PAXCDS20

NOTE: A PROGRAM LOCK-OUT JUMPER IS INSTALLED ON TIMER INPUT CONNECTIONS #7 AND #10. IT PREVENTS THE MACHINE OPERATOR FROM CHANGING PARAMETER SETTINGS. ONLY THE RUN TIME, RELAX TIME AND BATCH COUNTS ARE ABLE TO BE CHANGED BY THE MACHINE OPERATOR. TO CHANGE THE INTERNAL PARAMETER SETTINGS, REMOVE THE JUMPER FROM TIMER INPUT CONNECTION #7 AND REFER TO THE TIMER MANUAL FOR PROGRAMMING INSTRUCTIONS.

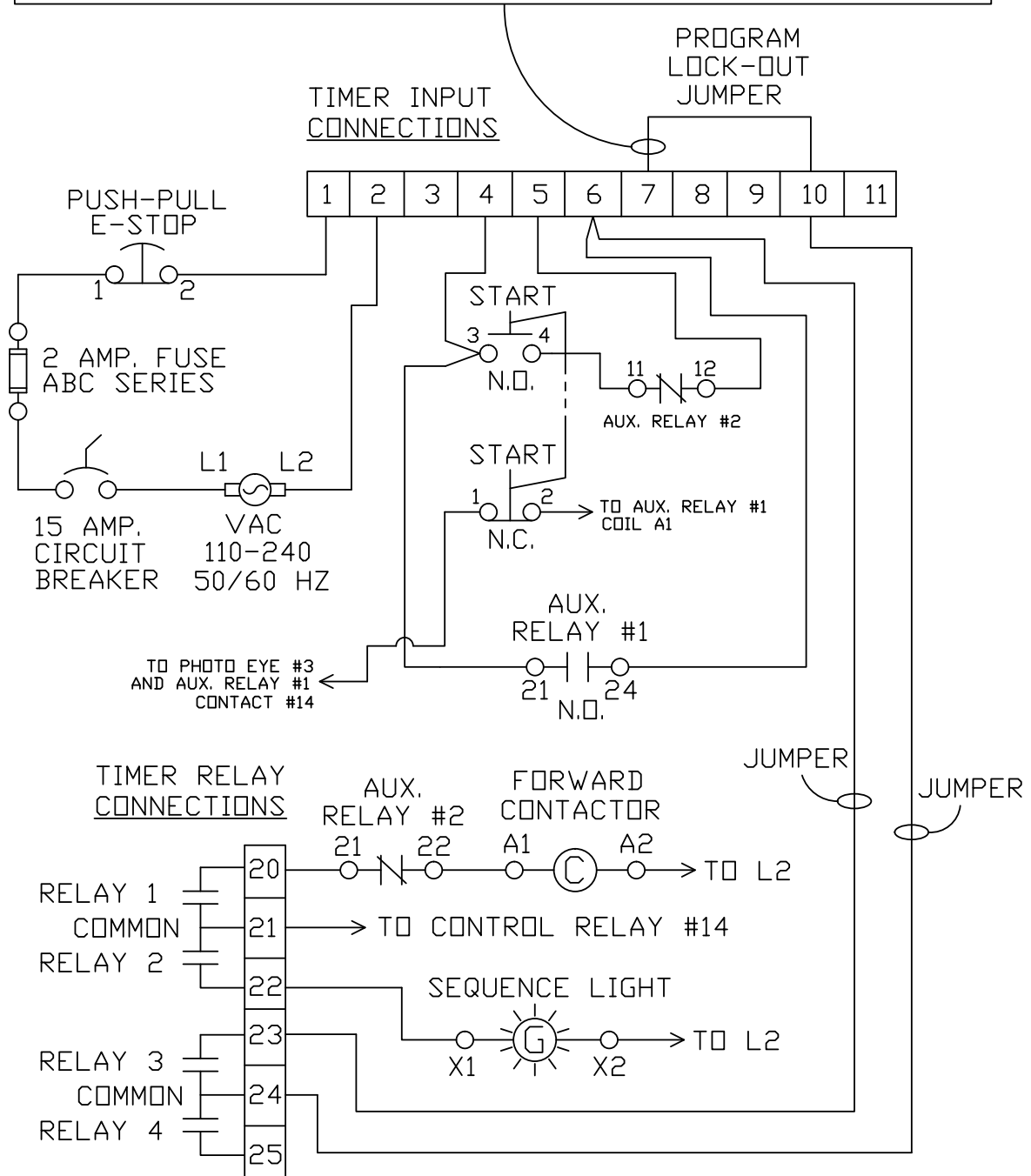

WIRING DIAGRAM
120/240 VAC 50/60Hz. 1PH.
NON PROGRAMMABLE TIMER (VTS492S)
DART POWER SUPPLY, FORWARD ROTATION ONLY

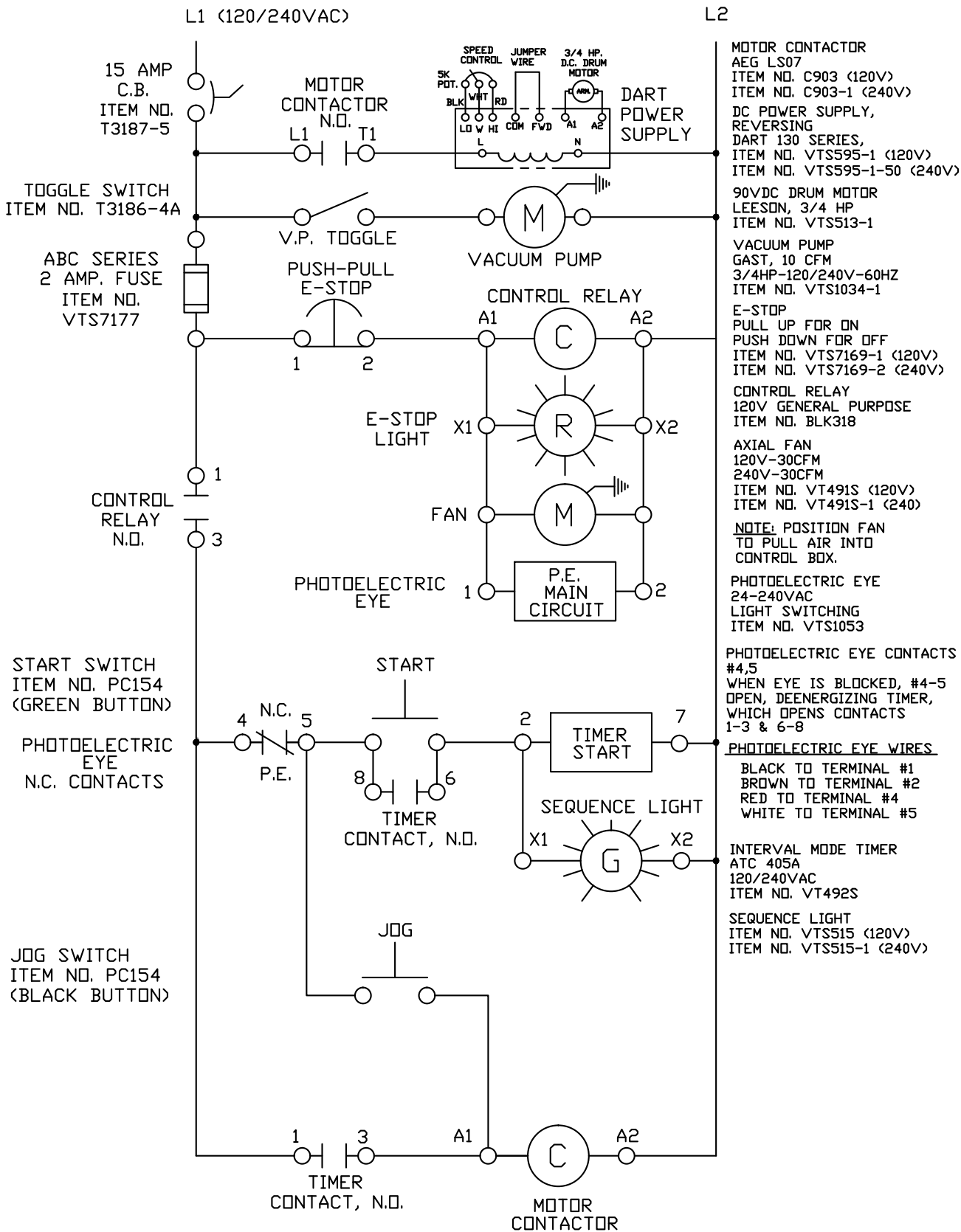

RECOMMENDED VTS-500 SPARE PARTS

Item No.	Description
VTS363-1	Drain cap
VTS529	Vacuum pump filter
VTS529-1	Filter elements
VTS568-1	Drum cover gasket, Starting with Serial 602
VTS626	Red Lion timer, Starting with Serial 782
VTS1053	Photoelectric eye
VTS1083-8	Lid latch

**COMMON DECALS
USED ON THE VTS-500**

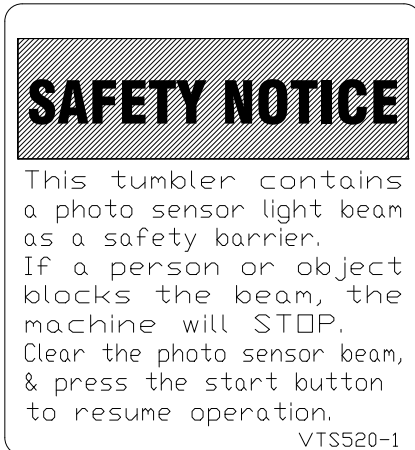

Item No. VTS520-1

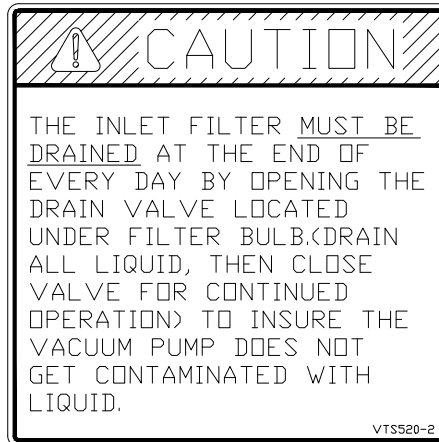

Item No. VTS520-2

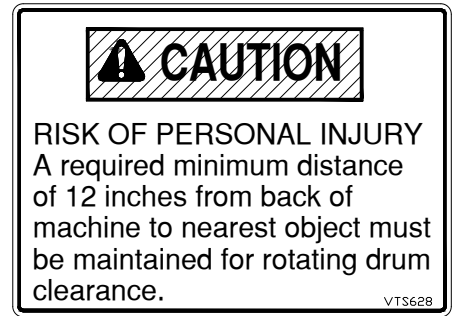

Item No. VTS628



Item No. VTS1097

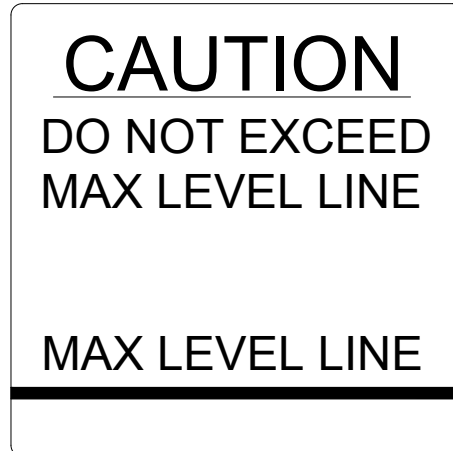

Item No. VTS1121



Item No. VT464S

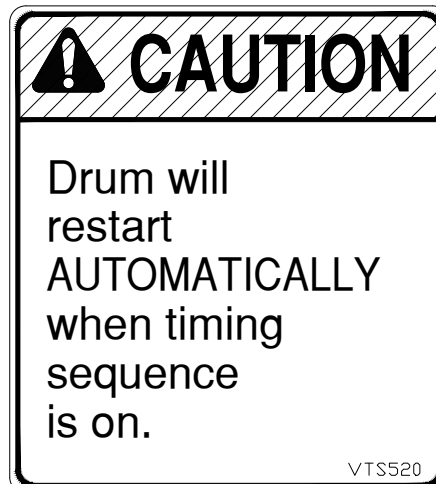

Item No. VTS520

-NOT TO SCALE-

LIMITED WARRANTY

WARRANTY: The BIRO Manufacturing Company warrants that the BIRO Vacuum Tumbler will be free from defects in material and workmanship under normal use and with recommended service. BIRO will replace defective parts, which are covered by this limited warranty, provided that the defective parts are authorized for return, shipping charges prepaid, to a designated factory for inspection and/or testing.

DURATION OF WARRANTY: The warranty period for all parts covered by this limited warranty is one (1) year from date of inspection/demonstration as advised on the returned warranty registration card, or eighteen (18) months from original factory shipping date, whichever date occurs first, except as noted below.

PARTS NOT COVERED BY WARRANTY: The following are **not** covered by this limited warranty: **VTS529-1** vacuum pump filter element, **VTS568-1** drum lid gasket. This limited warranty does not apply to machines sold as used, rebuilt, modified, or altered from the original construction in which the machine was shipped from the factory. Water contaminated electrical systems and **VTS1034-1** vacuum pump, are not covered under this limited warranty. BIRO is not responsible for electrical connection of equipment, adjustments to switch components or any other electrical requirements, which must be performed only by a certified electrician. BIRO is not responsible for service charges or labor required to replace any part covered by this limited warranty or for any damages resulting from misuse, abuse, lack of proper or recommended service. Failure to follow drum loading procedure will result in liquid collecting inside the vacuum pump which voids this warranty.

EXCLUSION OF WARRANTIES AND LIMITATION OF REMEDIES: BIRO gives no warranties other than those expressly stated in this limited warranty. THE IMPLIED WARRANTY OF MERCHANTABILITY, THE IMPLIED WARRANTY OF FITNESS FOR PROCESSING OF FOOD PRODUCTS, AND ALL OTHER IMPLIED WARRANTIES ARE SPECIFICALLY EXCLUDED. BIRO IS NOT LIABLE FOR CONSEQUENTIAL OR INCIDENTAL DAMAGES, EXPENSES OR LOSSES. THE REMEDIES PROVIDED IN THIS BIRO LIMITED WARRANTY ARE PURCHASER'S SOLE AND EXCLUSIVE REMEDIES AGAINST BIRO.

REGISTRATION CARDS: You must sign, date and complete the warranty registration card supplied with each machine. The warranty card must be returned to BIRO Manufacturing Company for proper registration. If no warranty card is returned to BIRO, the warranty period will begin from the date the machine was originally shipped from the factory.

HOW TO GET SERVICE:

1. Contact the agency from whom you purchased the machine; or
2. Consult the yellow pages of the phone directory for the nearest authorized dealer; or
3. Contact BIRO Mfg. Company for the nearest authorized service entity in your area.

BIRO MANUFACTURING COMPANY

1114 West Main St.
Marblehead, OH 43440
Ph. 419-798-4451
Fax 419-798-9106
Service@birosaw.com
www.birosaw.com