



VACUUM TUMBLER

OPERATION MANUAL & PARTS LIST

MODEL VTS-43

REMOTE PUMP



The BIRO VTS-43 VACUUM TUMBLER is a versatile machine used for vacuum tumbling all types of meats. The BIRO VTS-43 will produce equally impressive results with beef, pork, poultry and fish.

The unit is both easy to clean and maintain as well as sanitary in design and construction. The entire machine is built to give many years of trouble free service while providing a unique line of marinated products for your customers.

TABLE OF CONTENTS

	Page
NOTICE TO OWNERS AND OPERATORS	1
SAFETY TIPS	2
OPERATION	3
TO PROCESS PRODUCT	3
INSTRUCTIONS FOR PULLING A VACUUM	5
PARTS DIAGRAMS	6-11
WIRING DIAGRAMS	12
GENERAL MAINTENANCE	13
CLEANING	14
OPERATOR'S NOTES	15
OPERATOR'S SIGNATURE PAGE	16
LIMITED WARRANTY	17

NOTICE TO OWNERS AND OPERATORS

BIRO's products are designed to process food products safely and efficiently. Unless the operator is properly trained and supervised, however, there is the possibility of a serious injury. It is the responsibility of the owner to assure that this machine is used properly and safely, strictly following the instructions contained in this Manual and any requirements of local law.

No one should use or service this machine without proper training and supervision. All operators should be thoroughly familiar with the procedures contained in this Manual. Even so BIRO cannot anticipate every circumstance or environment in which its products will be used. You, the owner and operator, must remain alert to the hazards posed by the function of this equipment. No one under eighteen (18) years of age should operate this equipment. If you are uncertain about a particular task, ask your supervisor.

This Manual contains a number of safe practices in the SAFETY TIP section. Additional warnings are placed throughout the Manual. Warnings related to your personal safety are indicated by:



OR



Warnings related to possible damage to the equipment are indicated by:



BIRO also has provided warning labels on the equipment. If any warning label or Manual becomes misplaced, damaged, or illegible, please contact your nearest Distributor or BIRO directly for a replacement.

Remember, however, this Manual or the warning labels do not replace the need to be alert and to use your common sense when using this equipment.

- NOTE -

A copy of this manual is included with each MODEL VTS-43 VACUUM TUMBLER .

**The descriptions and illustrations contained in this manual are not binding.
The manufacturer reserves the right to introduce any modification without
updating the manual .**

SAFETY TIPS



ROTATING DRUM TO AVOID SERIOUS PERSONAL INJURY

***NEVER** Touch This Machine Without Training and Authorization By Your Supervisor.*

***ALWAYS** Read Operation and Service Manual **BEFORE** Operating, Cleaning or Servicing.*

***ALWAYS** Keep Hands Clear of the Rotating Drum and Other Moving Parts.*

***NEVER** Attempt to Remove the Drum Lid Unless Vacuum Has Been Released and the Drum is Positioned Vertically with the Lid at the Top.*

***NEVER** Operate Vacuum Pump Unless Properly Connected to Tumbler Drum.*

***ONLY** Operate Vacuum Pump in Recommended Vacuum Range (15-20 Inches of Mercury)
NEVER TO EXCEED 20 INCHES Hg.*

***ONLY** Use a Qualified Electrician to Install According to Local Building Codes: Machine **MUST** Be Properly Grounded.*

***ONLY** Install on Level, Non-Skid Surface in a Clean, Well-Lighted Work Area Away From Children and Visitors.*

***DO NOT** Store or Operate Machine in Meat Cooler.*

***DO NOT** Allow Food Particles, Liquids or Any Other Foreign Material to Enter the Vacuum Pump or Vacuum Hose.*

***ALWAYS** Turn Off, Unplug From Power Source and Perform Lockout/Tagout Procedure to This Machine **BEFORE** Attempting to Unjam or Unclog, Cleaning or Servicing.*

***NEVER** Leave Machine Unattended While Operating.*

***PROMPTLY REPLACE** Any Worn or Illegible Warning Labels.*

***USE ONLY BIRO** Parts and Accessories Properly Installed.*

***NEVER** Use The Motor Cover Plate for Preparing the Product.*

OPERATION



ROTATING DRUM TO AVOID SERIOUS PERSONAL INJURY

***ONLY** Properly Trained Personnel Should Use This Equipment.*

***ALWAYS** Keep Hands Clear of the Rotating Drum and Other Moving Parts.*

***DO NOT** Tamper With, Bypass, Alter, or Modify This Equipment in Any Way From Its Original Condition.*

***ALWAYS** Turn Off, Unplug From Power Source and Perform Lockout/Tagout Procedure to This Machine **BEFORE** Cleaning, Servicing, or When Not In Use.*

***NEVER** Leave Unattended While Operating.*

***DO NOT** Store or Operate Machine in Meat Cooler.*

***NEVER** Operate Without all Warning Labels Attached.*

***NEVER** Use The Motor Cover Plate for Preparing the Product.*

A. FOOD HANDLING TO PREVENT CONTAMINATION

1. **ALWAYS** wash hands thoroughly with warm soap and water before and after handling raw fish, poultry or meats.
2. **ALWAYS** clean and sanitize all utensils and surfaces that have been in contact with raw products.
3. **ALWAYS** store cold foods at or below 45° F (7.2° C).

B. TO PROCESS PRODUCT

1. Insert baffles into Stainless Steel drum. Be sure that baffles are fully engaged on mounting buttons.
2. Weigh product to be vacuum tumbled.
3. Refer to your ingredient chart for proper amount of marinade seasoning and water.
4. Place product, marinade, and water into tumbler drum.
5. Install gasket on drum lid and place lid on drum.
6. Connect vacuum hose to valve on drum lid. Be sure valve handle is in the open position, parallel with the valve body.
7. Plug vacuum pump into a grounded 60 Hz: 115 volt, 10 amp **OR** 50 Hz: **220** volt, 5 amp power source. Turn vacuum pump to “ON” while pressing down on center of lid. (Vacuum gauge will start indicating a vacuum is being pulled in the drum.) If needle in vacuum gauge does not indicate vacuum is being pulled, turn “OFF” vacuum pump and disconnect vacuum hose from drum lid. Remove drum lid and check that the lid gasket is properly installed and seated.

8. When vacuum gauge does indicate that a vacuum is being pulled, allow to continue running until gauge reads between 15 and 20 inches Hg. **NEVER EXCEED 20 Hg.**
9. Close valve handle on drum lid, Perpendicular to valve body. Turn vacuum pump to “OFF” position and unplug from power source. Remove vacuum hose from valve. Drum contents are now sealed in a vacuum.
10. Lay drum horizontally on roller with lid ends facing away from each other.
11. Plug tumbler motor into a grounded 60 Hz, 115 volt, 10 amp **OR** 50 Hz: 220 volt, 5 amp power source and turn toggle switch to “ON” position.
12. Turn timer control dial to desired time, and turn toggle switch to “ON TIMER” position.
13. When drum stops, turn toggle switch to “OFF” position, unplug tumbler motor from power source.
14. Remove drums and place on table with lids up. Turn valve handle to open position Parallel with valve body to release vacuum. Remove drum lid.
15. Remove product from drum.

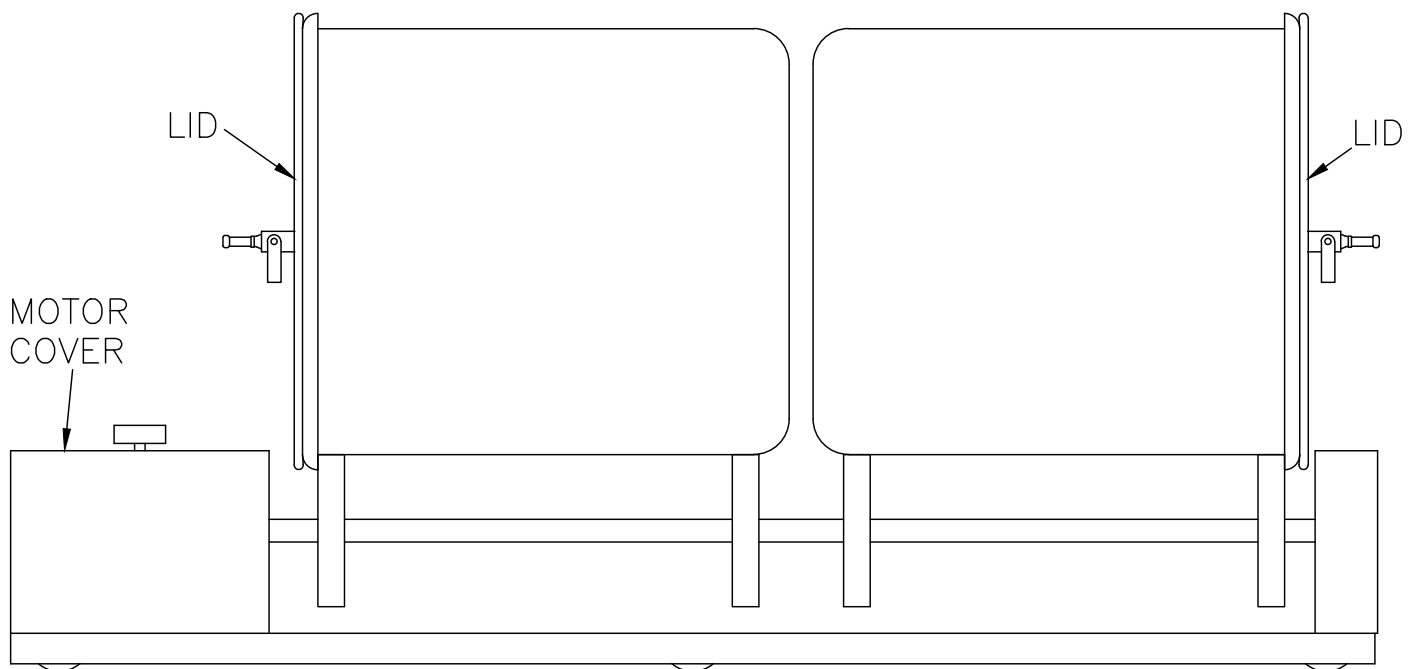

INSTRUCTIONS FOR PULLING A VACUUM

The following guidelines should be followed when using **BIRO** vacuum tumblers. Due to the nature of the manufacturing processes by which these drums and lids are made, there are slight differences in the diameter of the drum opening, and the diameter of the lid. These differences are normal, and have no impact on the performance of your tumbler.

- Make sure that the lid gasket is sealed properly.
- Center the lid in the opening of the drum.
- Start the vacuum pump.
- Apply pressure in the center of the lid.

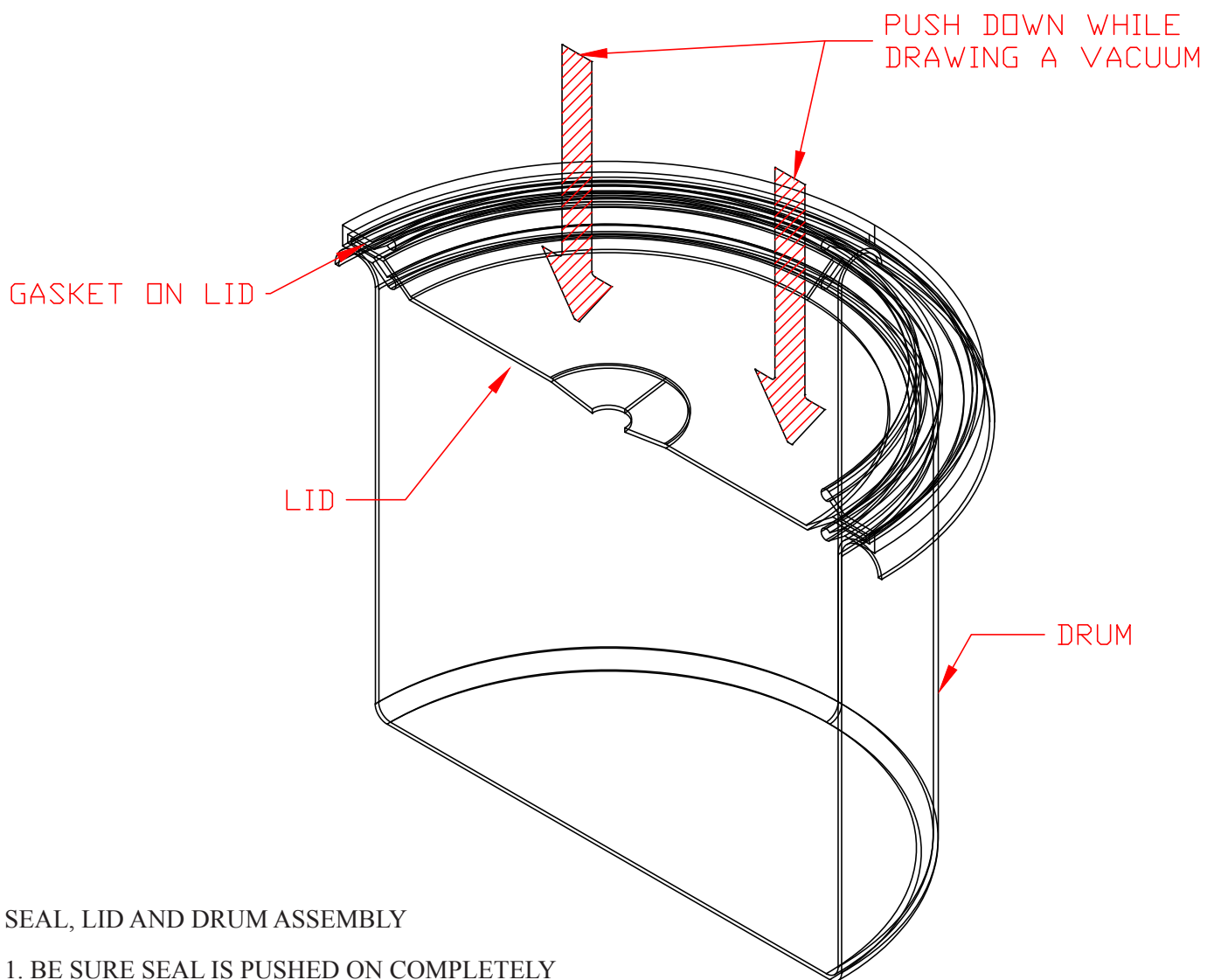

SEAL, LID AND DRUM ASSEMBLY

1. BE SURE SEAL IS PUSHED ON COMPLETELY
2. PUSH LID ON TO DRUM WHILE DRAWING A VACUUM

VTS-43 TUMBLER BASE

IMPORTANT: Always Advise Model & Serial Number When Ordering Parts

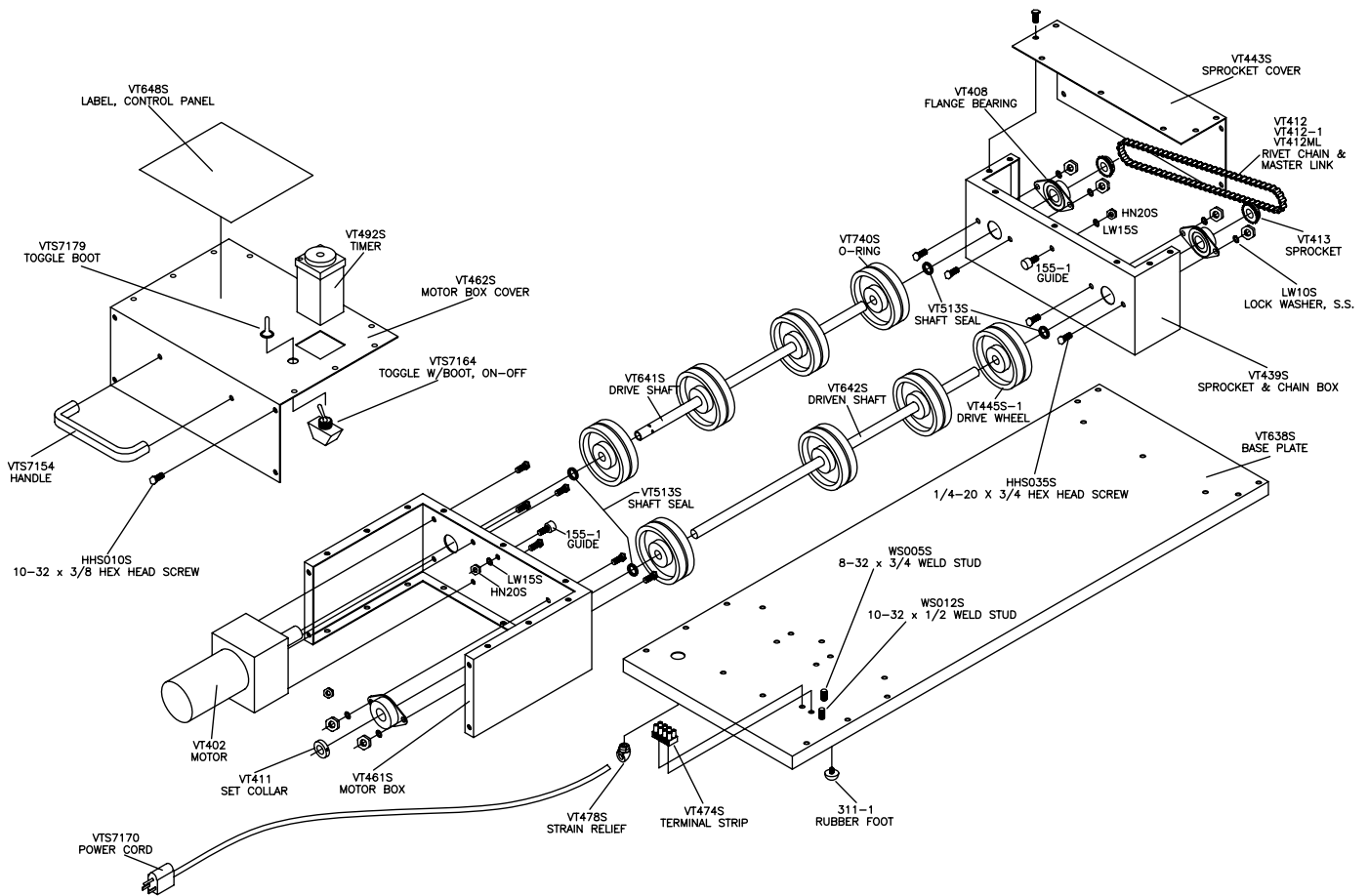

Item No.

- 155-1** Guide for 16" high drum
- 311-1** Rubber foot
- HHS010S** Hex head screw, 10-32 x 3/8, SS
- HHS035S** Hex head screw, 1/4 - 20 x 5/8, SS
- HN15S** Hex nut, 1/4 - 20, SS
- HN20S** Hex nut, 5/16-18, SS
- LW10S** Lock washer, 1/4, SS
- LW15S** Lock washer, 5/16, SS
- VT402** Motor, 1/25 HP, 115-60-1, 17.7 RPM. 90:1
- VT408** Flange bearing
- VT411** Set collar
- VT412** Rivet chain before serial. no. 43411
- VT412-1** Rivet chain after serial. no. 43412
- VT412ML** Master link- spring clip
- VT413** Sprocket
- VT439S** Sprocket & chain box less cover
- VT443S** Sprocket & chain cover
- VT445S-1** Drive wheel, with O-ring
- VT450S** Timer socket

Item No.

- VT461S** Motor box less cover
- VT462S** Motor box cover
- VT474S** Terminal strip, 4 circuit
- VT478S** Strain relief, 90 deg.
- VT492S** Timer w/out pushbutton start, 0-50 min.
- VT513S** Shaft seal
- VT638S** Tumbler base plate
- VT641S** Driving shaft
- VT642S** Driven shaft
- VT648S** Label, VTS-43 control panel
- VT740S** O-ring
- VTS7154** Oval handle
- VTS7164** Toggle switch w/ boot, ON-OFF
- VTS7170** Power cord w/ 120V plug, 8', 16/3
- VTS7179** Toggle switch boot

NOT SHOWN

- VT418** Vacuum pump w/ toggle, 110-60-1
- VT479S** Vacuum pump w/ toggle, 220-50-1

VTS-43

IMPORTANT: Always Advise Model & Serial Number When Ordering Parts

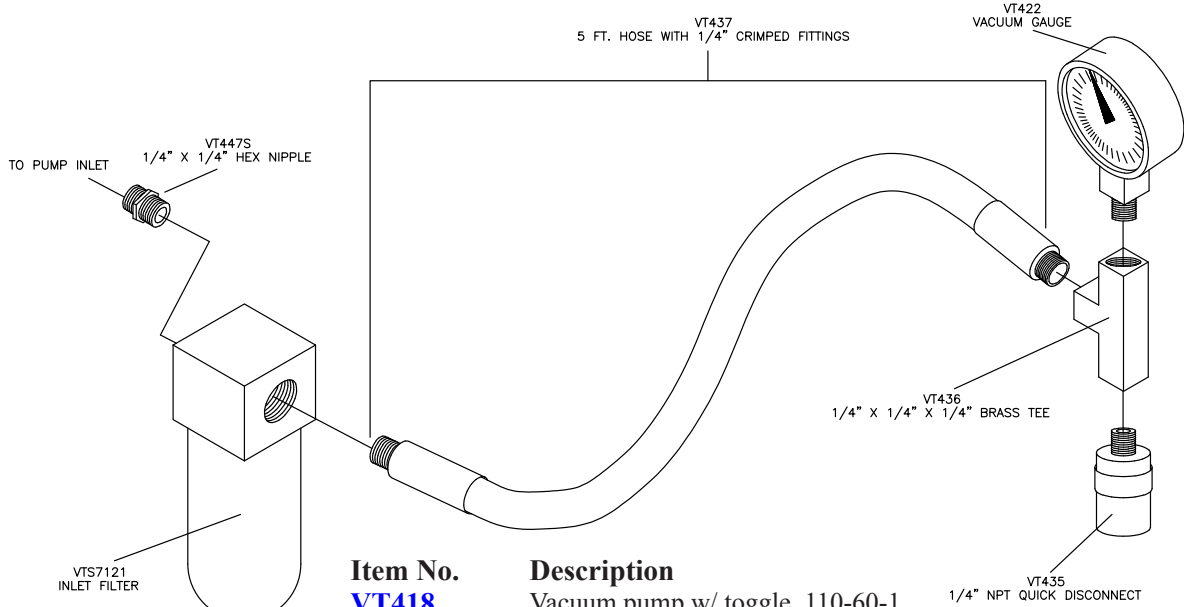

Item No.	Description
VT418	Vacuum pump w/ toggle, 110-60-1
VT422	Vacuum gauge
VT435	Coupler, 1/4 MPT
VT436	Tee, 1/4 x 1/4 x 1/4 FPT, brass
VT437	Hose, 5' with 1/4 MPT crimped ends
VT447S	Hex nipple, 1/4 NPT
VT479S	Vacuum pump w/ toggle, 220-50-1
VTS7121	Inlet filter

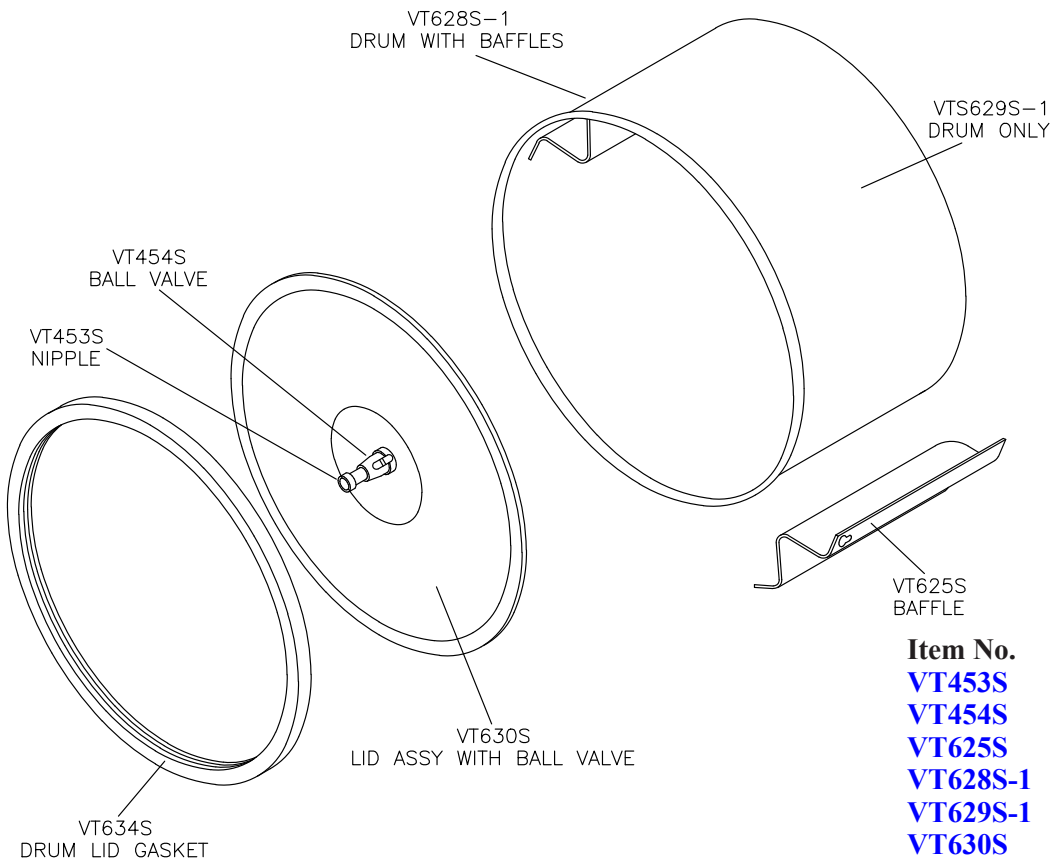

VT635S DRUM & LID ASSEMBLY

Item No.	Description
VT453S	Nipple only
VT454S	Ball valve only
VT625S	Baffle only, for double drum
VT628S-1	Drum with baffles
VT629S-1	Drum only, without baffles
VT630S	Lid assembly with ball valve
VT634S	Drum lid gasket, double drum
VT635S	Drum & lid assembly

ITEM No. **VTS7121**

INLET FILTER DRAINING INSTRUCTIONS

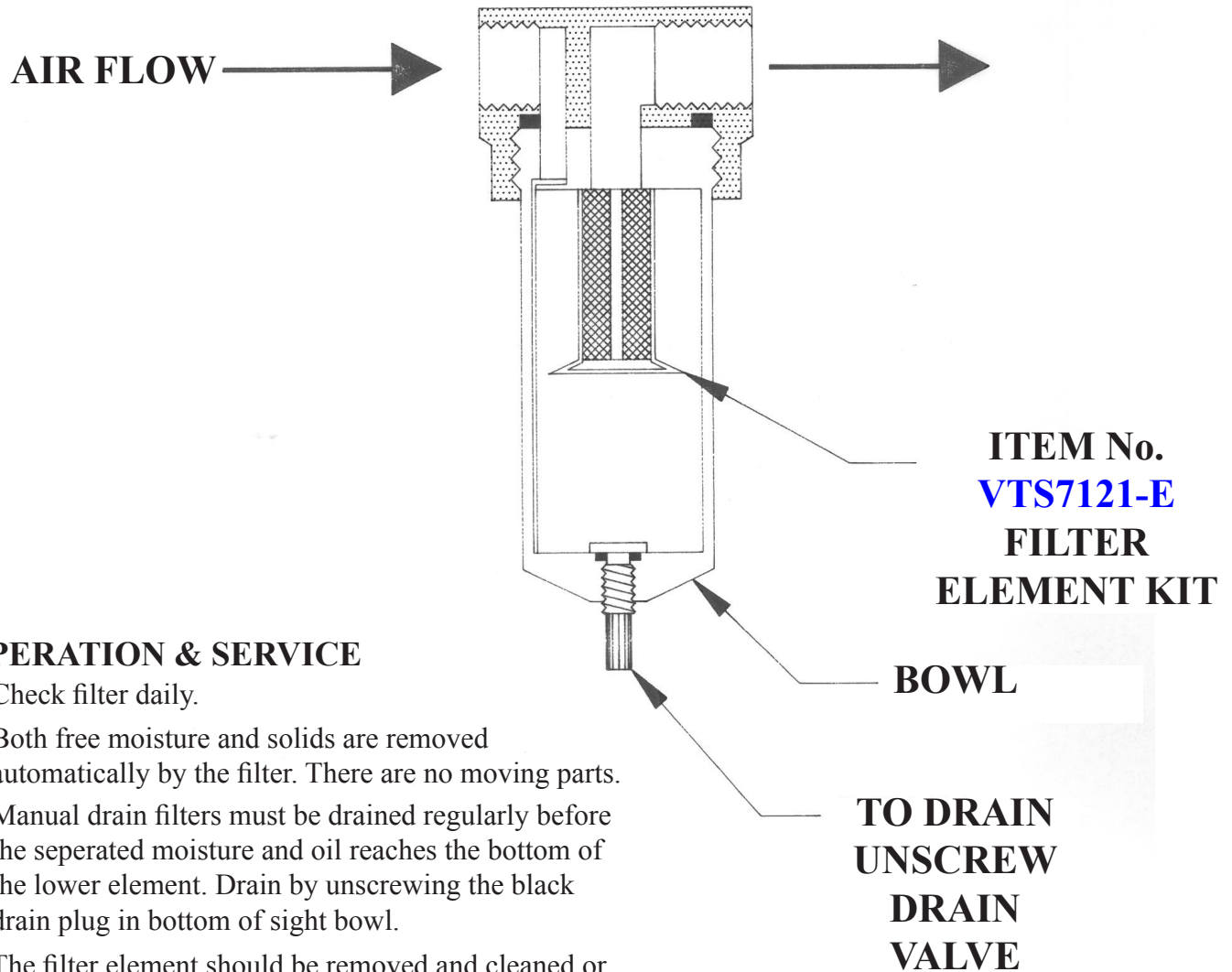

OPERATION & SERVICE

1. Check filter daily.
2. Both free moisture and solids are removed automatically by the filter. There are no moving parts.
3. Manual drain filters must be drained regularly before the separated moisture and oil reaches the bottom of the lower element. Drain by unscrewing the black drain plug in bottom of sight bowl.
4. The filter element should be removed and cleaned or replaced monthly.
5. To remove the filter element: **SHUT OFF VACUUM PUMP** and depressurize the unit.
 - a. Unscrew threaded bowl.
 - b. Unscrew element assembly.
 - c. Clean bowl and filter element. Reassemble or replace filter element. Clean bowl with mild soap and water only. Do not use detergents, cleansing agents, such as acetone, alcohol, benzene or gasoline, which are damaging to plastic.
 - d. Lubricate or replace bowl gasket to assist initial sealing. Use only mineral based oils or grease. Do not use synthetic oils or silicones.
 - e. Screw bowl into body of filter. Close black drain plug.

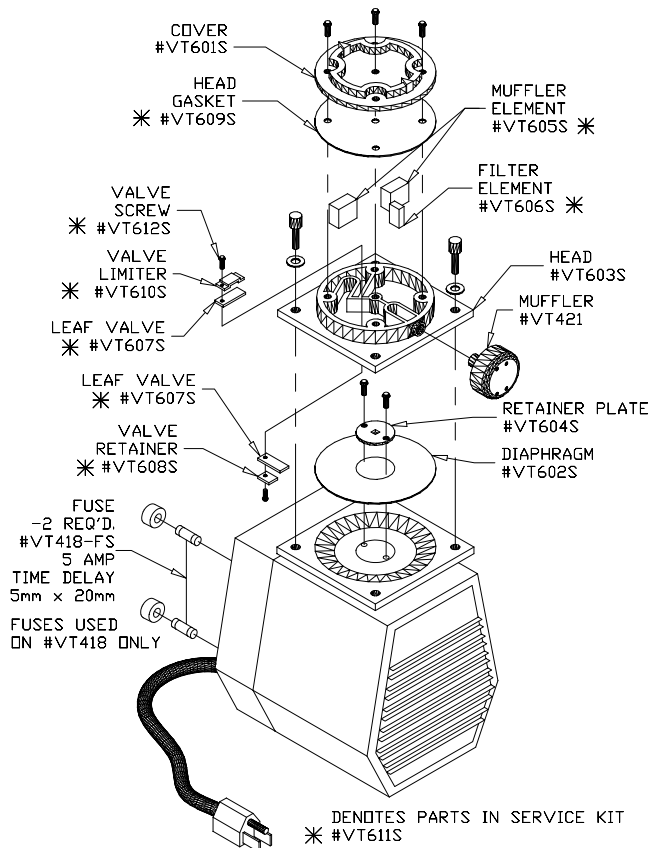

**VT418
OR
VT479S
VACUUM PUMP
ASSEMBLY**

**NO. VT611S
SERVICE REPAIR KIT**

OPERATING AND MAINTENANCE INSTRUCTIONS

Do not at any time lubricate any of the parts with oil, grease, or petroleum products nor clean with acids, caustics or chlorinated solvents. Be very careful to keep the diaphragm from contacting any petroleum product or hydro carbons. It can affect the service life of the pump.

WARNING: To prevent explosive hazard, Do NOT pump combustibile liquids or vapors with these units. Personal Injury and/or Property Damage would result.

To clean or replace the internal filters and/or rubber gasket, remove the five screws in the top of the unit. The filters and gasket are located beneath this top plate. Remove the filters and wash them in solvent and/or blow off with air or replace. The gasket may be cleaned with water. Replace the filters in proper position and replace the gasket. Note that the gasket and top plate will fit in one position only.

To replace the diaphragm, remove the socket cap screws from the head of the pump. The diaphragm is held in place by two phillips head screws. Remove screws, retainer plate and the diaphragm. The diaphragm will fit in any position on the connecting rod. Replace the plate and the two phillips head screws. Torque to 30 inch-pounds.

CAUTION: Do not raise any burrs or nicks on the heads of these screws. These burrs could cause damage to the inlet valve.

For replacing the inlet and the outlet valve, remove the slotted machine screw that holds each valve in place. The stainless steel inlet and outlet valves are interchangeable*. Clean them with water. When replacing the outlet valve, place the new valve in location and note there is a retaining bar near the machine screw hole. The retaining bar holds the valve in position. When replacing the inlet valve, note that the valve holder is marked with an X in one corner. This X should be in the lower right hand corner toward the inlet of the air chamber. Replace the head and tighten the socket head screws, to 90-100 inch-pounds of torque.

WARNING: The motor may be thermally protected and can automatically restart when the overload resets. Always disconnect power source before servicing. Personal Injury and/or Property Damage could result.

Do not attempt to replace the connecting rod or motor bearings. If after cleaning the unit and/or installing a new Service Kit, the unit still does not operate properly, contact your representative, the factory, or return the pump to one of our authorized Service Centers.

IF YOUR PUMP IS EQUIPPED WITH PLASTIC PLUGS IN THE EXHAUST AND/OR INTAKE PORTS, REMOVE BEFORE STARTING THE UNIT.

OLD STYLE EXTERNAL VACUUM PUMPS

Exploded Product View, Parts, and Ordering Information

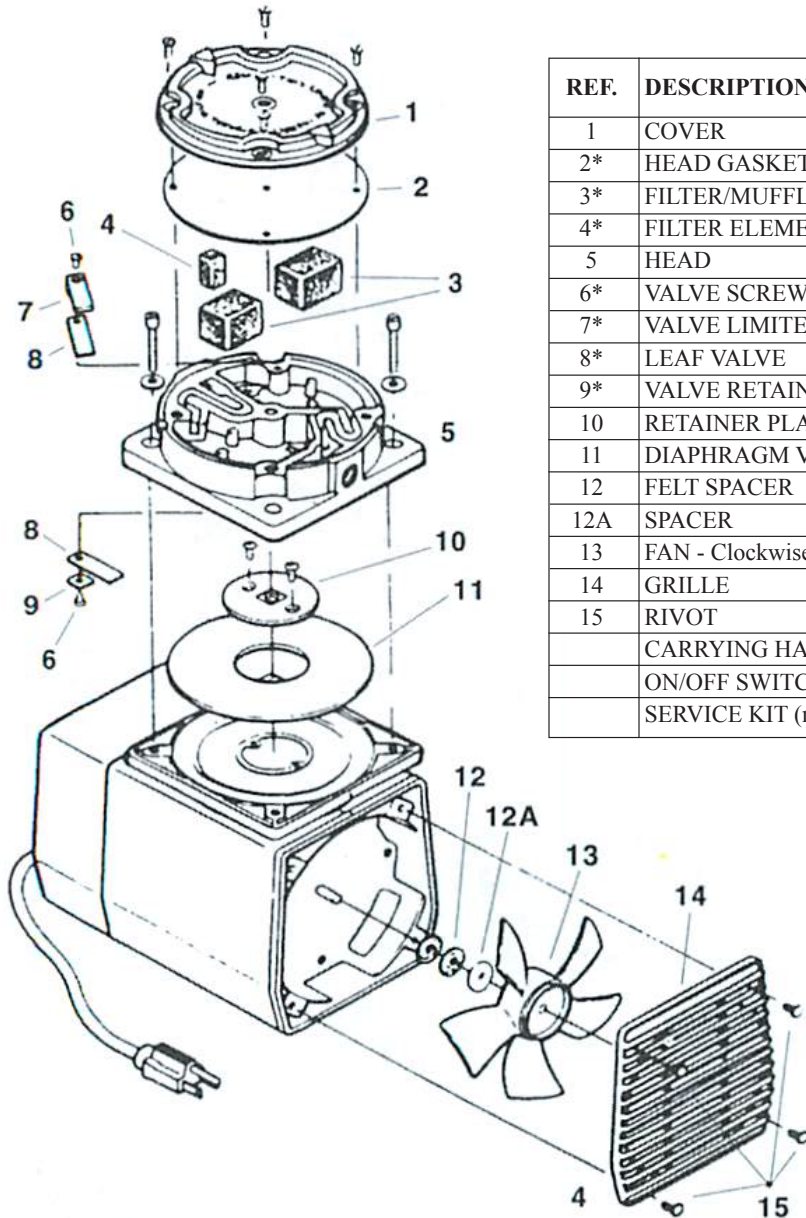

REF.	DESCRIPTIONS	Qty	DOL-101-AA
1	COVER	1	VTS-AF808
2*	HEAD GASKET	1	VTS-AF820
3*	FILTER/MUFFLER ELEMENT	2	VTS-AF713
4*	FILTER ELEMENT	1	VTS-AT712A
5	HEAD	1	VTS-AF804
6*	VALVE SCREW	2	VTS-BB317
7*	VALVE LIMITER	1	VTS-AF856
8*	LEAF VALVE	2	VTS-AF817
9*	VALVE RETAINER	1	VTS-AF819A
10	RETAINER PLATE	1	VTS-AF809
11	DIAPHRAGM VACUUM- RED	1	VTS-AF818B
12	FELT SPACER	3	VTS-AA929
12A	SPACER	1	VTS-AD996
13	FAN - Clockwise	1	VTS-AT837
14	GRILLE	1	VTS-AF807
15	RIVOT	4	VTS-AE946
	CARRYING HANDLE (not shown)	1	VTS-AP523A
	ON/OFF SWITCH (not shown)	1	VTS-AF875
	SERVICE KIT (not shown)	1	VT611S

* Denotes parts included in the Service Kit.

* The Service Kit may contain parts for more than one model or style diaphragm part.

When corresponding or ordering parts, please give complete model and serial numbers.

NEW STYLE EXTERNAL VACUUM PUMPS

Exploded Product View, Parts, and Ordering Information

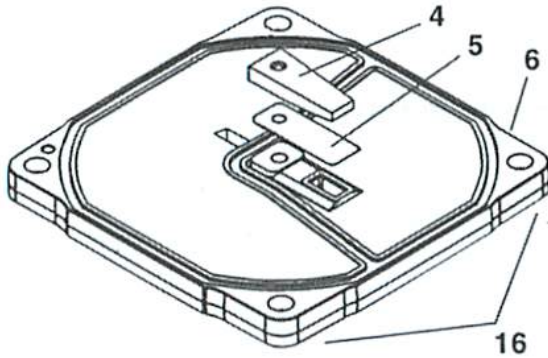

Valve Plate Assembly (available separately)
 (Valve Plate Assembly also includes items 7 & 8
 as shown in the main exploded view)

REF.	DESCRIPTIONS	Qty	DOA-V722-AA DOA-V502-BN DOL-701-AA
1	HEAD	1	VTS-AP500
2*	HEAD O-RING	1	VTS-AP513
3*	FILTER/MUFFLER ELEMENT	2	VTS-AT712A
4*	VALVE LIMITER	1	VTS-AP110
5*	LEAF VALVE	2	VTS-AF817
6	VALVE PLATE	1	VTS-AP504
7*	VALVE RETAINER	1	VTS-AF819A
8*	VALVE SCREW	1	VTS-BB330A
9	RETAINER PLATE	1	VTS-AF809
10	DIAPHRAGM-VACUUM	1	VTS-AF818B
11	FELT SPACER	3	VTS-AA929
12	SPACER	1	VTS-AD996
13	FAN- DOA, DOL	1	VTS-AF533
14	GRILLE	1	VTS-AF807
15	RIVOT	4	VTS-AP534
16	VALVE PLATE ASSEMBLY	1	VTS-AP519
17	CRANKCASE COVER	1	VTS-AP526
18	CRANKCASE COVER SCREW	2	VTS-AP525
19	5 AMP TIME DELAY FUSE	2	VT418-FS
	CARRYING HANDLE (not shown)	1	VTS-AP523A
	ON/OFF SWITCH (not shown)	1	VTS-AF875
	SERVICE KIT (not shown)	1	VT611S

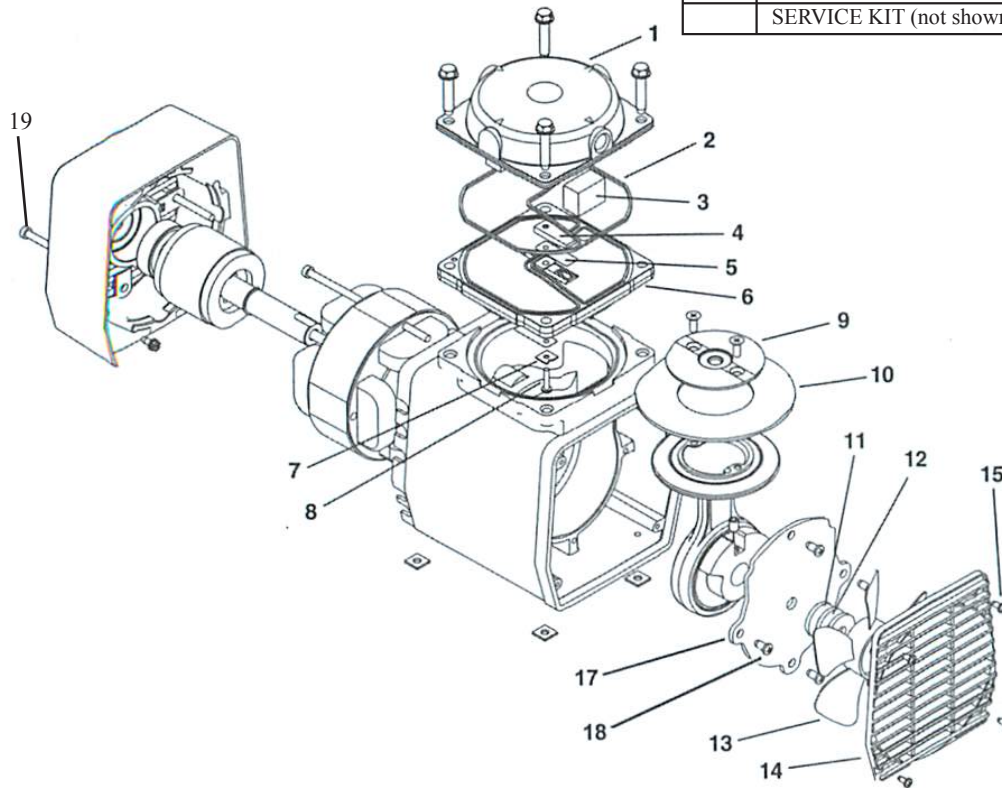

* Denotes parts included in the Service Kit.

* The Service Kit may contain parts for more than one model or style diaphragm part.
 Parts not needed may be discarded.

When corresponding or ordering parts, please give complete model and serial numbers.

VTS-43 WIRING DIAGRAM

IMPORTANT: Always Advise Model & Serial Number

115 VOLTS - 60 HERTZ - 1 PHASE

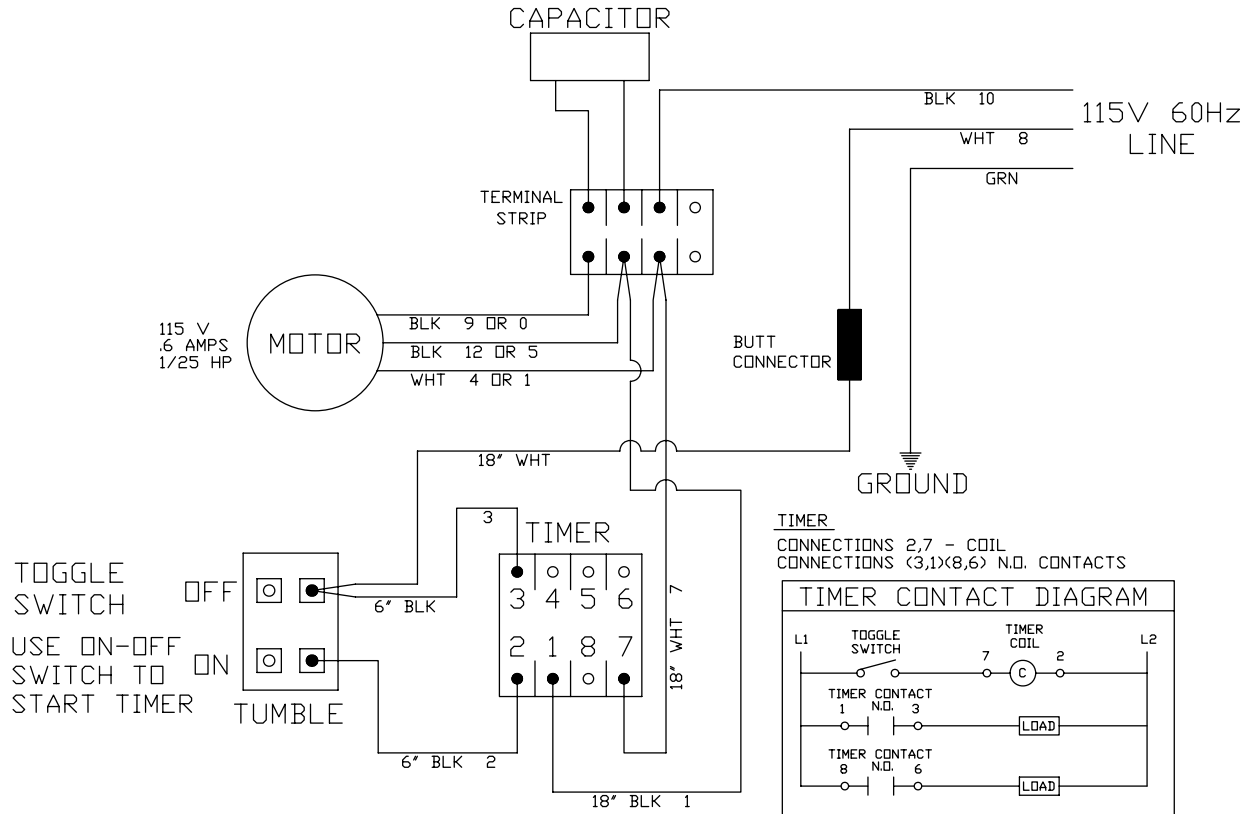

WIRING DIAGRAM FOR VARIABLE SPEED

115 VOLTS - 60 HERTZ - 1 PHASE

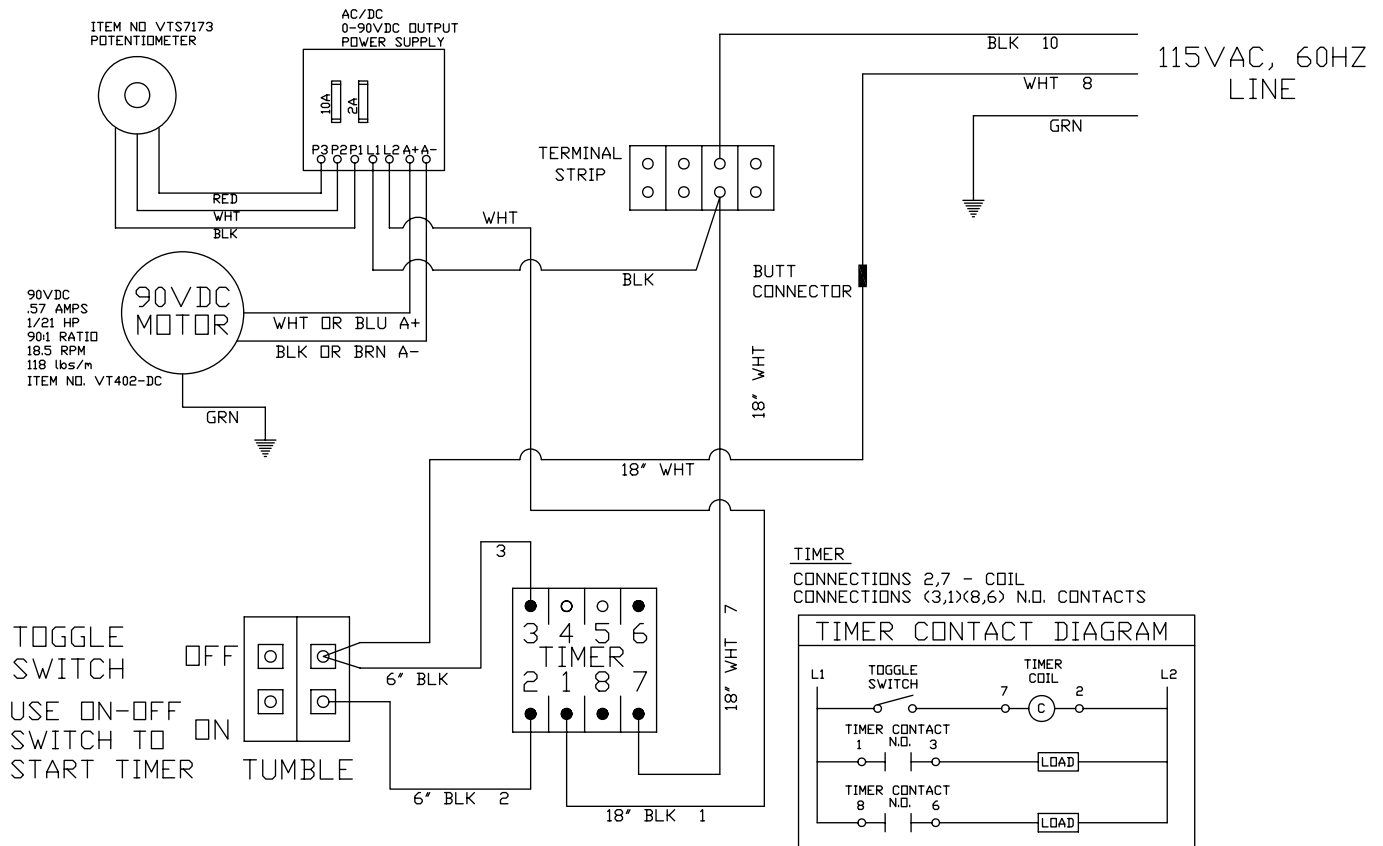

GENERAL MAINTENANCE



ROTATING DRUM TO AVOID SERIOUS PERSONAL INJURY

***ALWAYS** Turn Off, Unplug From Power Source and Perform Lockout/Tagout Procedure to This Machine **BEFORE** Servicing.*

***NEVER** Touch This Machine Without Training and Authorization By Your Supervisor.*

***NEVER** Bypass, Alter, or Modify This Equipment in Any Way From Its Original Condition.*

***PROMPTLY REPLACE** Any Worn or Illegible Warning Labels.*

***USE ONLY BIRO** Parts and Accessories Properly Installed.*

A. PUMP FILTER

1. Check filter daily. Filter must be drained before the separated moisture and oil reaches the bottom of the lower filter element. Drain by unscrewing the black drain plug in bottom of sight bowl.
2. The filter element should be removed and cleaned monthly.
 - a. Unscrew clear threaded bowl.
 - b. Unscrew filter element assembly.
 - c. Clean bowl and filter element. Reassemble or replace filter element. Clean bowl with mild soap and water only. Do not use detergents, cleansing agents, such as acetone, alcohol, benzene or gasoline, which are damaging to plastic.
 - d. Lubricate bowl gasket to assist initial sealing. Use only mineral based oils or grease. Do not use synthetic oils or silicones.
 - e. Screw bowl into body of filter. Close black drain plug.

B. VACUUM PUMP

WARNING: The motor is thermally protected and can automatically restart when the overload resets. Always disconnect from power source before servicing. Personal Injury could be the result.

1. Do not at any time lubricate any of the parts with oil, grease, or petroleum products or clean with acids, caustics or chlorinated solvents. Never allow the diaphragm to contact any petroleum products. This can reduce greatly the service life of the vacuum pump.
2. To clean or replace the internal filters and/or rubber gasket, remove the five screws in the top of the pump. The filter and gasket are located beneath this top plate. Remove the filters and wash them in solvent and/or blow off with air or replace. The gasket may be cleaned with water. Replace the filters in proper position and replace the gasket. The gasket and top plate will fit in one position only.
3. To replace the diaphragm, remove the socket cap screws from the head of the pump. The diaphragm is held in place by two phillips head screws. Remove screws, retainer plate and the diaphragm. The diaphragm will fit in any position on the connecting rod. Replace the plate and the two phillips head screws. Torque to 30 inch-pounds.

CAUTION: Do not raise any burrs or nicks on the heads of these screws. These burrs could cause damage to the inlet valve.

CLEANING



ROTATING DRUM TO AVOID SERIOUS PERSONAL INJURY

ALWAYS Turn Off, Unplug From Power Source and Perform Lockout/Tagout Procedure to This Machine **BEFORE** Cleaning or Servicing.

ONLY Use Recommended Cleaning Equipment, Materials and Procedures.

NEVER Spray Water or Other Liquid Substances Directly at Motor, Power Switch or any Other Electrical Components.

ALWAYS Thoroughly Clean Equipment at Least Daily.



DO NOT Use Harsh Chemicals, Scouring Pads or Cleansers. Ordinary Liquid Detergent for Manual Dish or Pot/Pan Washing Will Not Harm the Machine. Harsh Machine Chemicals Will Cause Brown “Rusty” Stains, as will Chlorine Bleach and Similar Products if Allowed to Stand in or on the Machine for Any Length of Time.

CLEANING THE BIRO VACUUM TUMBLER:

1. Turn “OFF”, unplug machine from power source, and perform lockout/tagout procedures.
2. The drum, drum lid, baffles in Stainless Steel drum and gasket can be removed and washed in utensil sink. Be sure to flush the vacuum valve with warm soapy water and rinse with clean water thoroughly. The drum, drum lid, baffles from Stainless Steel drum and gasket should be sanitized with an appropriate sanitizer approved by your local Health Dept. All parts should be air dried before reassembly and storage.
3. The exterior of the tumbler base can be wiped down with the same type soap solution followed by a rinse water wiping.
4. If food stains are not removed, use a product such as “Bon Ami” or “Soft Scrub”. Be sure to scrub with the grain of the Stainless Steel with a soft cloth or sponge.
5. Streaks or water spots can usually be removed with a solution of vinegar and water.

OPERATOR'S NOTES

LIMITED WARRANTY

WARRANTY: The BIRO Manufacturing Company warrants that the BIRO Vacuum Tumbler will be free from defects in material and workmanship under normal use and with recommended service. BIRO will replace defective parts, which are covered by this limited warranty, provided that the defective parts are authorized for return, shipping charges prepaid, to a designated factory for inspection and/or testing.

DURATION OF WARRANTY: The warranty period for all parts covered by this limited warranty is one (1) year from date of inspection/demonstration as advised on the returned Warranty registration card, or eighteen (18) months from original factory shipping date, whichever date occurs first, except as noted below.

PARTS NOT COVERED BY WARRANTY: The following are **not** covered by this limited warranty: **VT57121** vacuum pump inlet filter, **VT634S** drum lid gasket, and **VT454S** ball valve on drum lid. This limited warranty does not apply to machines sold as used, rebuilt, modified, or altered from the original construction in which the machine was shipped from the factory. Water contaminated electrical systems are not covered under this limited warranty. BIRO is not responsible for electrical connection of equipment, adjustments to switch components or any other electrical requirements, which must be performed only by a certified electrician. BIRO is not responsible for service charges or labor required to replace any part covered by this limited warranty or for any damages resulting from misuse, abuse, lack of proper or recommended service.

EXCLUSION OF WARRANTIES AND LIMITATION OF REMEDIES: BIRO gives no warranties other than those expressly stated in this limited warranty. THE IMPLIED WARRANTY OF MERCHANTABILITY, THE IMPLIED WARRANTY OF FITNESS FOR PROCESSING OF FOOD PRODUCTS, AND ALL OTHER IMPLIED WARRANTIES ARE SPECIFICALLY EXCLUDED. BIRO IS NOT LIABLE FOR CONSEQUENTIAL OR INCIDENTAL DAMAGES, EXPENSES OR LOSSES. THE REMEDIES PROVIDED IN THIS BIRO LIMITED WARRANTY ARE PURCHASER'S SOLE AND EXCLUSIVE REMEDIES AGAINST BIRO.

REGISTRATION CARDS: You must sign, date and complete the warranty registration card supplied with each machine. The warranty card must be returned to The Biro Manufacturing Company for proper registration. If no warranty card is returned to BIRO, the warranty period will begin from the date the machine was originally shipped from the factory.

HOW TO GET SERVICE:

1. Contact the agency from whom you purchased the machine; or
2. Consult the yellow pages of the phone directory for the nearest authorized dealer; or
3. Contact Biro Mfg. Company for the nearest authorized service entity in your area.

BIRO MANUFACTURING COMPANY

1114 Main Street

Marblehead, OH 43440 U.S.A.

Telephone: 419-798-4451 Fax: 419-798-9106

E-mail: service@birosaw.com Web: www.birosaw.com