



**MODEL 44SSFH
FIXED HEAD POWER MEAT SAW
OPERATING AND SERVICE MANUAL
STARTING WITH SERIAL NO. 9105**



☆ **IMPORTANT NOTICE** ☆

This Manual contains important safety instructions which must be strictly followed when using this equipment.

TABLE OF CONTENTS:

	PAGE
NOTICE TO OWNERS AND OPERATORS	1
SAFETY TIPS	2
INSTALLATION	3-5
WARNING LABEL LOCATIONS ON MACHINE	6
WALL CHART (PART NO. 671)	7
OPERATION	8
TO PROCESS PRODUCT	9
MAINTENANCE	9 & 10
GENERAL	10
LUBRICATION	10
CLEANING	11
PARTS DIAGRAMS	12 -19
OPERATOR'S NOTES	19
SWITCH ASSEMBLIES AND SERVICE PARTS	20 & 22
WIRING DIAGRAMS	21 & 23
OPERATOR'S NOTES	24
WEARABLE SAW PARTS LIST	25
PARTS LIST / ORDERING	26 - 27
PARTS ASSEMBLIES LIST / ORDERING	27
OPERATOR'S NOTES	28
OPERATOR'S SIGNATURE	29
LIMITED WARRANTY	30

NOTICE TO OWNERS AND OPERATORS

BIRO's products are designed to process food products safely and efficiently. Unless the operator is properly trained and supervised, there is the possibility of a serious injury. It is the responsibility of the owner to assure that this machine is used properly and safely, strictly following the instructions contained in this Manual and any requirements of local law.

No one should use or service this machine without proper training and supervision. All operators should be thoroughly familiar with the procedures contained in this Manual. Even so BIRO cannot anticipate every circumstance or environment in which its products will be used. You, the owner and operator, must remain alert to the hazards posed by the function of this equipment - particularly the SHARP MOVING BAND TYPE SAW BLADE. No one under eighteen (18) years of age should operate this equipment. If you are uncertain about a particular task, ask your supervisor.

This Manual contains a number of safe practices in the SAFETY TIP section. Additional warnings are placed throughout the Manual. Warnings related to your personal safety are indicated by:



OR



Warnings related to possible damage are indicated by:



BIRO also has provided a wall chart to be posted near the equipment. If any warning label, wall chart, or Manual becomes misplaced, damaged, or illegible, please contact your nearest Distributor or BIRO directly for a replacement.

Remember, however, this Manual or the warning labels do not replace the need to be alert and to use common sense when using this equipment.

This Manual applies to machines with serial number 9105 and higher, except where noted.

- NOTE -

**“A copy of this manual is included with each MODEL 44SSFH
FIXED HEAD POWER MEAT SAW.”**

**“The descriptions and illustrations contained in this manual are not binding.
The manufacturer reserves the right to introduce any modification without
updating the manual.”**

SAFETY TIPS



SHARP MOVING BAND TYPE SAW BLADE TO AVOID SERIOUS PERSONAL INJURY

***NEVER** Touch This Machine Without Training and Authorization By Your Supervisor.*

***ALWAYS** Read Operation and Parts Manual **BEFORE** Operating, Cleaning or Servicing.*

***ALWAYS** Keep Hands Clear of Sharp Band Type Saw Blade and Other Moving Parts.*

***ONLY** Use a Qualified Electrician to Install According to Local Building Codes: Machines **MUST** Be Properly Grounded.*

***ONLY** Install on Level, Non-Skid Surface in a Clean, Well-Lighted Area Away From Children and Visitors.*

***DO NOT** Attempt to Operate This Machine Until it has Been Inspected and Demonstrated by the Seller - Recognized **BIRO** Representative.*

***DO NOT** Alter or Modify This Machine in any Way From its Original Form. This Machine in its Original Form Meets the Intent of O.S.H.A. Applicable Standards.*

***NEVER** Operate with Saw Guard on Saw Guide Bar in the Raised Position or the Saw Guard Removed from the Saw Guide Bar.*

***ALWAYS** Adjust the Saw Guide Bar with Saw Guard to Within 1/2" of Product to be Cut.*

***ALWAYS** Use Supplied Safety End Cut Pusher Plate for Smaller Products or The Last Cuts of Products.*

***DO NOT** Use This Machine for Non-Food Products.*

***DO NOT** Use This Machine to Cut Pigs Feet.*

***DO NOT** Wear Gloves While Operating.*

***ALWAYS** Turn Off, Unplug From Power Source and Perform Lockout/Tagout Procedure to This Machine **BEFORE** Removing Shrouds, Removable Guards, Covers, Doors, Fences or Panels for Cleaning, Servicing or Any Other Reason.*

***NEVER** Leave Machine Unattended While Saw is Running.*

***PROMPTLY REPLACE** Any Worn or Illegible Warning Labels.*

***USE ONLY BIRO** Parts and Accessories Properly Installed.*

INSTALLATION



TO AVOID SERIOUS PERSONAL INJURY PROPERLY INSTALL EQUIPMENT IN ADEQUATE WORK AREA

ALWAYS Use Qualified Technician and Electrician for Installation.

ALWAYS Install Equipment in Work area with Adequate Light and Space.

ONLY Operate on a Solid, Level, Non-Skid Surface.

NEVER Operate with Saw Guard on Saw Guide Bar in the Raised Position or the Saw Guard Removed from the Saw Guide Bar.

ALWAYS Adjust Saw Guide Bar with Saw Guard to Within 1/2" of Product to be Cut.

NEVER Operate Without all Warning Labels Attached and Wall Chart Posted.

1. Read this Manual thoroughly before installation and operation. **Do not** proceed with installation and operation if you have any questions or do not understand anything in this Manual. Contact your local Distributor, or BIRO first.
2. Install machine on a level, solid, non-skid surface in a well-lighted work area away from children and visitors.



ALWAYS LEVEL MACHINE BEFORE USING

3. After installing machine in operational are, it is imperative that the four adjusting leg hex bolts be adjusted to level the machine and also to eliminate rocking.
4. To assemble the meat gauge plate (Part No. [A18275](#)) to the machine, loosen the lock knob (Part No. 272-7) on the right side of meat gauge bracket. Raise the meat gauge gear rack (Part No. 18272) and slip the meat gauge plate over the gear rack. Lower the gear rack back to its original position, tighten lock knob. Keep gear rack well oiled with a food grade oil to ensure free movement.

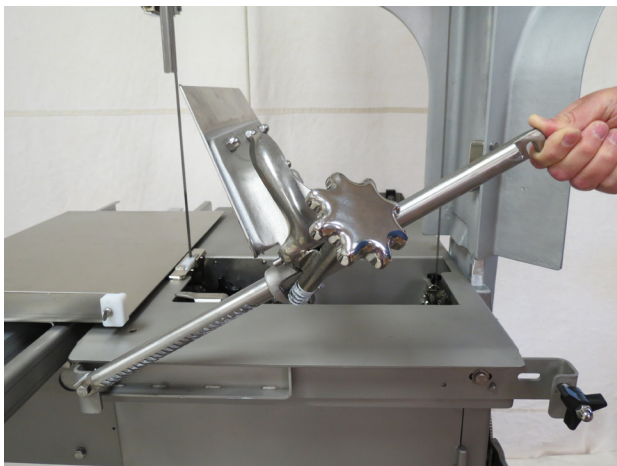

5. Place removable finger lift with saw guard assembly on the saw guide bar and fasten in place with four point finger lift fastener knob.
6. The side platter bracket is packed loose in the machine and must be installed on the left side of the base structure with the supplied hardware and checked for proper adjustment.
7. Machine **MUST** be properly grounded. Use qualified electrician to install according to building codes.



**FINGERLIFT
ASSEMBLY**

WIRING MOTOR

1. Interchange of motor current is made in motor outlet box. Leads are properly marked. Changing instructions are on motor plate or inside junction box cover.
2. All saws are wired **220** volts unless otherwise specified. Be sure motor specifications (voltage, cycle, phase) match power supply line. Be sure line voltage is up to specification.
3. Connect leads to machine in a manner that will be approved by local electrical inspectors.
4. We recommend no less that No. 12 wire. If the leads are too light, machine may not have sufficient cutting power and/or speed.
5. The drive belt is packed loose in machine to prevent deformation, and must be installed on pulleys at time of wiring motor.
6. The BIRO Manufacturing Company is not responsible for permanent wiring, connection or installations.



NOTE TO OWNER AND ELECTRICIAN: IF THIS MACHINE IS NOT CORD AND PLUG CONNECTED TO THE ELECTRICAL SUPPLY SOURCE, THEN IT SHOULD BE EQUIPPED WITH, OR CONNECTED TO, A LOCKABLE, MANUALLY OPERATED DISCONNECT SWITCH (1010.147 OSHA).

8. All machines are tested at the factory, but electrical phasing for proper rotation may not match your electrical supply. All machines must be first test run for proper phasing.



SHARP SAW BLADE. HANDLE WITH EXTREME CAUTION.

9. Placing blade on cutter: Unpack upper wheel assembly and hang on the hinged bracket in the head structure. Lift the nylon filler in the stationary bar. Hang the blade on the upper wheel and hold with right hand. With the left hand force the back of the blade between the front blade scrapers, located below the stationary bar. Lower the nylon filler. Be sure the blade is in the upper saw guide. The blade has dropped over the lower wheel. Switch hands holding the blade on the upper wheel. With the right hand, force the blade between the rear blade scrapers. The blade is now ready to be tightened.

10. Turn the blade tensioning handle clockwise until the tension mark is even with the bottom of the upper wheel hinge plate as shown. Carefully turn saw wheels by hand and watch for proper tracking of blade on the wheels.

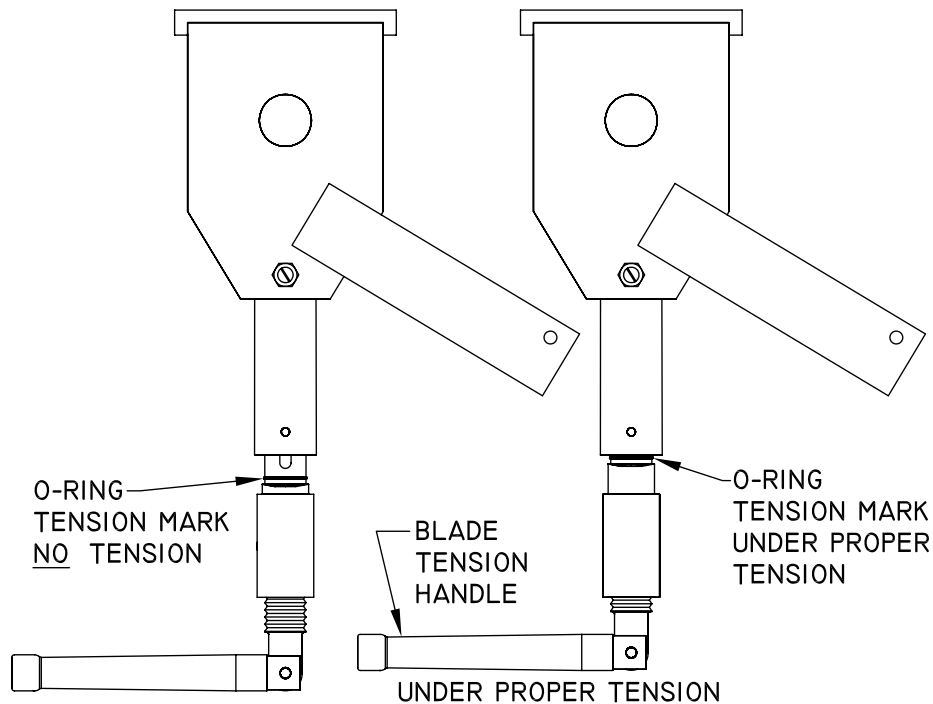

11. The stationary platter is placed on top of the base structure and held in place by two platter hold down catches located in the base structure.
12. The sliding meat carriage assembly is installed on the channel. Start by turning the movable stop assembly clockwise. After the carriage assembly has been installed on the channel for operation, turn the movable stop assembly counterclockwise to lock.
13. Make sure saw guide bar with saw guard is in its lowest position. Close head and base doors.



**KEEP HAND CLEAR OF SHARP MOVING BAND TYPE SAW
BLADE**

14. Push the start button. Check for proper phasing of the motor and proper tracking of the saw blade in the saw guides. Back of the blade should be centered in the lower saw guide in the stationary bar. Blade should be moving down through the guide. Push the stop button to stop machine.
15. Check placement of all warning labels, wall chart and Manual. Machine is ready for trained operators to process product.
16. Contact your local Distributor or BIRO directly if you have any questions or problems with the installation or operation of this machine.

WARNING LABEL LOCATIONS ON MACHINE



ATTACH TO CHANNEL BRACKET
NEXT TO SWITCH BUTTONS



ATTACH ON HEAD STRUCTURE
MODEL/SERIAL NUMBER TAG



P/N 720 BLADE
TENSION ADJUSTMENT
DECAL

LOCATED INSIDE
HEADDOOR

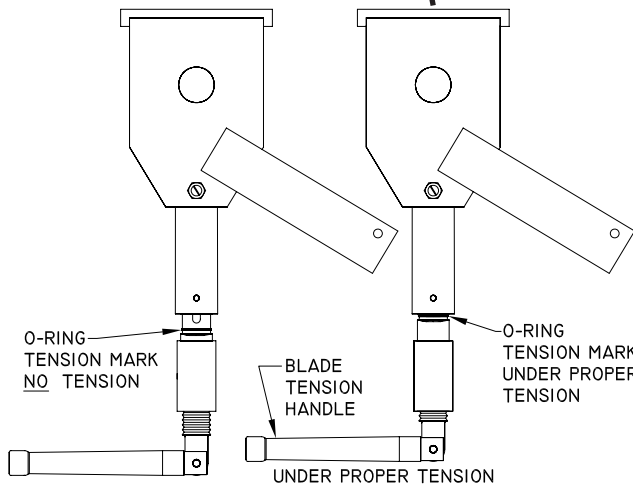

WARNING

DO NOT Use Unless Trained and Authorized By Supervisor And Over 18 Years Old. READ Operation Manual Thoroughly Before Operating. ALWAYS Keep Hands Clear of Saw Blade and other Moving Parts. Turn Off Saw when Finished Cutting. ALWAYS Keep Blade Guard Adjusted to 1/2" Above the Product being Cut. ALWAYS Use End Cut Pusher Plate When Cutting Smaller Piece of Product. DO NOT Use Saw if it is Altered, Damaged, Improperly Maintained, or If Warnings Are Illegible or Missing. ALWAYS Disconnect and Unplug from Main Power Source and Perform LOCKOUT/TAGOUT Before Cleaning or Servicing. Failure to comply with warning could result in serious bodily injury.

#653PC-E

ALWAYS
LOWER
GUARD
TO
HEIGHT
OF
PRODUCT



DANGER
EXPOSED
BLADE
↓

P/N 708 "DANGER EXPOSED
BLADE" DECAL

ATTACHED TO SAW GUARD
ON SAW GUIDE BAR

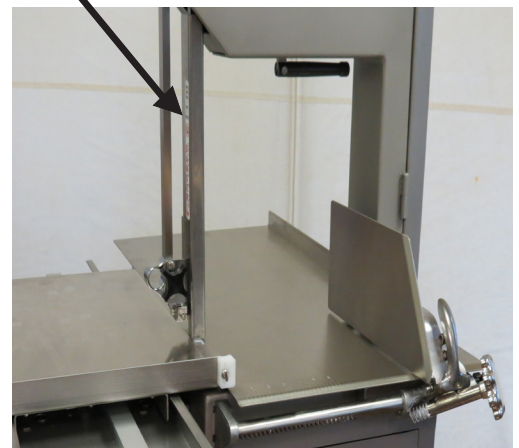

★★★★ NOT TO SCALE ★★★★★

ITEM NUMBER 671
WALL CHART “BAND SAW SAFETY GUIDELINES”
ATTACH TO WALL IN VICINITY OF MACHINE IN EASY VIEW OF OPERATOR



WARNING

ONLY TRAINED OPERATORS SHOULD USE THIS EQUIPMENT

This Saw Contains A Sharp Blade.
To Avoid Serious Injury:

1. Inspect Before Operating:

- Gauge Plate (A) and Blade Guard Are Secure.
- All Warning Labels And Guards Are In Place.
- The Guide Bar (B) Is Adjusted to 1/2 Inch Above The Product To Be Cut

2. While Cutting:

- Keep Hands And Fingers Away From Blade.
- Keep Product Securely Against Gauge Plate (A).
- Use End Cut Pusher (C) When Making Final Cuts. Item No. 256P.

3. Before Cleaning:

- Turn Off Power And Follow Lockout / Tagout Procedure.
- Remove Saw Blade.
- Use Extra Care When Handling The Saw Blade.

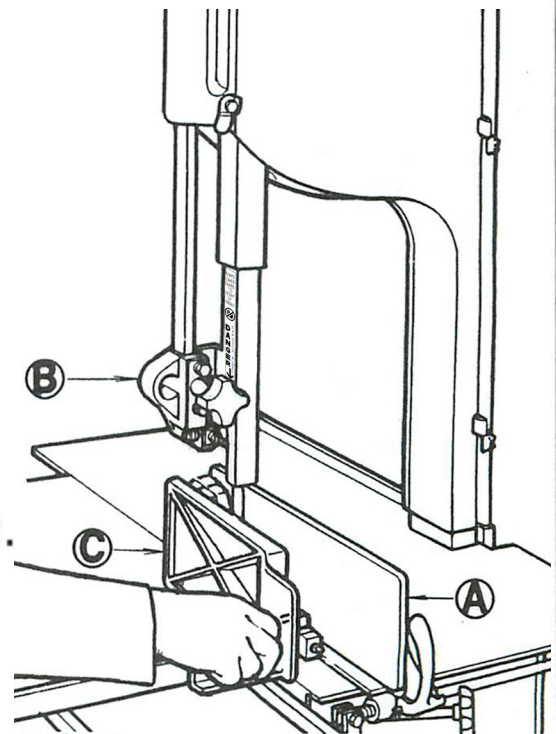

USE YOUR MEAT SAW SAFELY!

SEE PARTS AND SERVICE MANUAL SUPPLIED WITH MACHINE FOR ADDITIONAL SAFETY INFORMATION.

#671

OPERATION



SHARP MOVING BAND TYPE SAW BLADE

TO AVOID SERIOUS PERSONAL INJURY

***ONLY** Properly Trained Personnel Should Use This Equipment.*

***ALWAYS** Read Operating and Parts Manual **BEFORE** Operating.*

***ALWAYS** Keep Hands Clear of Band Type Saw Blade and Other Moving Parts.*

***DO NOT** Tamper With, Bypass, Alter, or Modify this Equipment in Any Way or Form.*

***DO NOT** Alter or Modify This Machine in any Way From its Original Form. This Machine in its Original Form Meets the Intent of O.S.H.A. Applicable Standards.*

***NEVER** Operate with Saw Guard on Saw Guide Bar in the Raised Position or the Saw Guard Removed from the Saw Guide Bar.*

***ALWAYS** Adjust the Saw Guide Bar with Saw Guard to Within 1/2" of Product to be Cut.*

***ALWAYS** Use Safety End Cut Pusher Plate for Smaller Products or The Last Cuts of Product.*

***DO NOT** Use This Machine for Non-Food Products*

***DO NOT** Use This Machine to Cut Pigs Feet.*

***DO NOT** Wear Gloves While Operating.*

***ALWAYS** Turn Off, Unplug from Power Source and Perform Lockout/Tag Out Procedures Before Cleaning, Servicing or When Not in Use.*

***NEVER** Leave Machine Unattended While The Saw is Running.*

***NEVER** Operate Without All Warning Labels Properly Affixed to Machine.*

A. FOOD HANDLING TO PREVENT CONTAMINATION

1. **ALWAYS** wash hands thoroughly with warm soap and water before and after handling raw fish, poultry or meats.
2. **ALWAYS** clean and sanitize all utensils and surfaces that have been in contact with raw products.
3. **ALWAYS** store cold foods at or below 45 deg. F (7.2 deg. C).

B. TO PROCESS PRODUCT

1. Before starting power saw, adjust saw guide bar with saw guard to within ½” of product to be cut. “B”

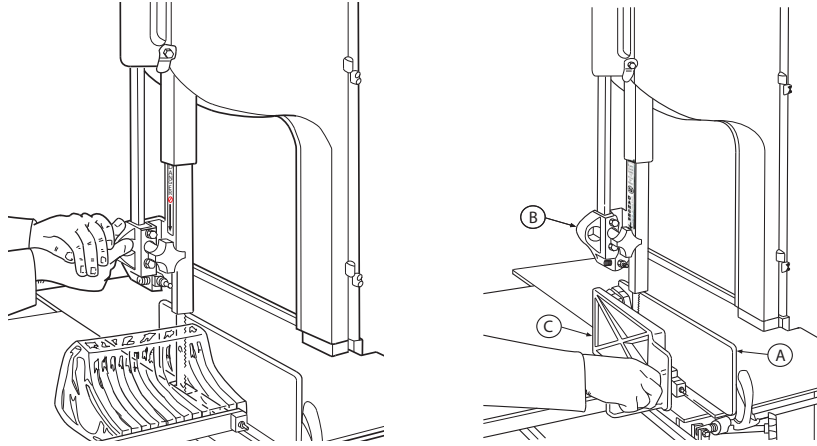

DO NOT WEAR GLOVE WHILE OPERATING

2. Make sure all doors are closed and locked.
3. Adjust meat gauge plate forward to desired thickness of cut. “A”
4. Push start button and watch blade for proper tracking.
5. Standing in front of the power saw, place product on the meat carriage. Pay attention to position of your hands. Keep hands clear of moving band type saw blade. Leaning lightly against the scalloped front edge of meat carriage, hold the product firmly in right hand with product face flush against the meat gauge plate. Move the meat carriage from right to left at a steady rate until fully past the saw blade. Use the left hand to remove and stack cut product, **NEVER REACH IN FRONT OF BAND TYPE SAW BLADE**. On the return stroke, pull the product slightly toward you to clear the blade.



NEVER REACH OR GRAB FOR PRODUCT IN FRONT OF MOVING BAND TYPE SAW BLADE

6. **ALWAYS** use the Safety End Cut Pusher Plate for smaller products or the last cuts of product. “C” The pusher plate is supplied as standard on all Biro power saws.
7. When finished cutting, push stop button. Perform lockout/tag out procedure.

MAINTENANCE



! WARNING
TO AVOID SERIOUS PERSONAL INJURY



ALWAYS Turn Off, Unplug from Power Source and Perform Lockout/Tag Out procedure to This Machine ***BEFORE*** Cleaning or Servicing.

NEVER Touch This Machine Without Training and Authorization By Your Supervisor.

ALWAYS Keep Hands Clear of Band Type Saw Blade and Other Moving Parts.

NEVER Bypass, Alter, or Modify This Equipment in Any Way From Its Original Condition.

PROMPTLY REPLACE Any Worn or Illegible Warning Labels.

USE ONLY GENUINE BIRO Parts and Accessories Properly Installed.

A. GENERAL

1. Machine should be generally inspected every time it is cleaned (at least daily) to ensure that it is in good condition and has not been damaged or tampered with.
 - a. SAW WHEELS: Clean outer diameter grooves daily. Check for cracks, gouges or wear on the flange and grooves.
 - b. WHEEL CLEANER ASSEMBLIES: Check condition of fiber cleaner, change every four (4) weeks.
 - c. REMOVABLE FINGER LIFT ASSEMBLY: Check condition of saw guard, make sure mounting bolts are tight and the "DANGER EXPOSED BLADE" decal is affixed and legible. Check condition of upper saw guide, replace every 6 months. Check adjustment of upper saw guide. Should be 1/32" between back of blade and saw guide carbide.
 - d. SAW GUIDE BAR: Check condition of bar for wear, replace if necessary.
 - e. STATIONARY BAR ASSEMBLY: Check condition of nylon filler, change every 4 weeks. Check condition of saw guide, check tracking of blade through guide. Back of blade should be centered in hole, replace every 6 months.
 - f. SAW CLEANERS: Check condition of blade cleaners, replace every 4 weeks.
 - g. MEAT GAUGE ASSEMBLY: Check free movement of meat gauge plate on gear rack. Gear rack to be kept lubricated at all times with light food grade oil. Check operation of release handle. Check that worm gear engages properly with gear rack.
 - h. MEAT CARRIAGE ASSEMBLY: Check free movement through full range of travel. Check side to side for excessive clearance, adjust as necessary. Check condition of and grease bearings, replace as necessary. Check condition of thumb guard, replace as necessary.
 - i. SAFETY ITEMS: Safety end cut pusher plate is with machine and accessible. All warning labels are present and legible. Model and Serial Number plate is affixed and legible. Manual accessible to operator.

B. LUBRICATION

1. **UPPER WHEEL BEARINGS:** Grease every four (4) months. Change grease every twelve (12) months.
(See instructions at right.)
2. **LOWER BEARING HOUSING:** Grease every four (4) months. Change grease every twelve (12) months.
3. **MEAT CARRIAGE BEARINGS:** Grease every four (4) weeks.
4. **SAW GUIDE BAR:** Oil daily with food machine oil.
5. **MEAT GAUGE GEAR RACK:** Oil daily with food machine oil.
6. **BLADE TENSION SPRING SCREW ASSEMBLY:** Grease every 4 weeks- NOTE: Remove upper wheel and turn #14782 Blade Tension screw clockwise until it bottoms out against #14781 Blade Tension Handle then fill the cavity under the O-Ring on the #14782 Blade Tension Screw with #374 Shell Cassida Grease EPS-2 and re-assemble.
7. **MOTOR BEARINGS:** Bearing grease will lose its lubricating ability over time, not suddenly. The lubricating ability of a grease (over time) depends primarily on the type of grease, the size of the bearing, the speed at which the bearing operates and the severity of the operating conditions. Good results can be obtained if the following recommendations are used in your maintenance program.

A high grade ball or roller bearing grease should be used. Recommended grease for standard service conditions is Polyrex EM (Exxon Mobil).

Equivalent and compatible greases include: Texaco Polystar, Rykon Premium #2, Pennzoil Pen 2 Lube, and Chevron SRI.

Recommended lubrications intervals is every 9 months with the equivalent of two (2) teaspoons of grease.

USE BIRO No. 374 GREASE FOR RE-GREASING SEE INSTRUCTIONS BELOW

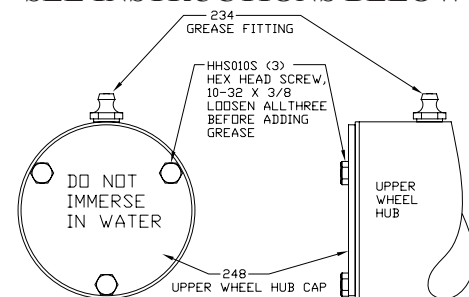

When lubricating the upper wheel bearing it is important that the three hex head screws securing the upper wheel hub cap be loosened slightly before attempting to pump grease into the grease fitting. Loosening the screws allows for an escape of old broken down grease and air from the bearing cavity. Failure to loosen the screws before greasing the upper bearings can cause the upper shaft seal to be dislodged from the upper wheel allowing grease to escape and moisture to get into the cavity. When finished greasing the bearings, re-tighten the three screws. Take care to also clean off any grease that pushed out of the cavity during greasing.

CLEANING



SHARP MOVING BAND TYPE SAW BLADE

TO AVOID SERIOUS PERSONAL INJURY

ALWAYS Turn Off, Unplug from Power Source and Perform Lockout/Tag Out procedure to This Machine **BEFORE** Cleaning or Servicing.

ONLY Use Recommended Cleaning Equipment, Materials and Procedures.

NEVER Spray Water or Other Liquid Substances Directly at Motor, Power Switch or any Other Electrical Components.

ALWAYS Thoroughly Clean Equipment at Least Daily.

CLEANING THE BIRO POWER SAW:

Disconnect electrical power to the machine before cleaning. Parts to be removed have been made accessible and can be removed without tools. Notice in the drawing below that all parts are numbered. Each part should be removed for cleaning in the numbered sequence shown. To ensure cleaner cuts, keep the parts on the cleaning system in good condition. Parts on the cleaning system which should be checked weekly, and changed as required are as follows: Wheel Cleaners (Part No. 179), Saw Cleaners (Part No. 131), Saw Guide in Stationary Bar (Part No. S119A), Upper Saw Guide (Part No. S602B), Lower Blade Back-Up Guide (Part No. S608), and Nylon Filler (Part No. 177).

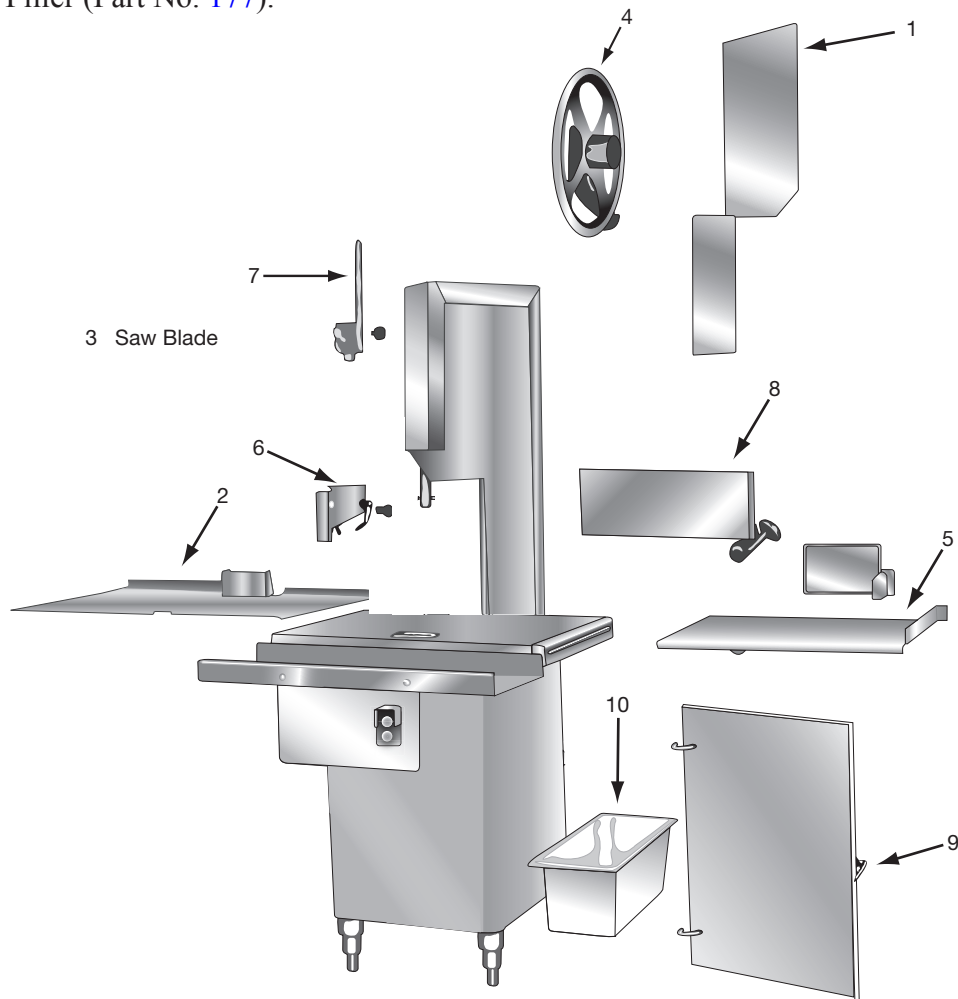

NOTE:
ALWAYS REPORT MACHINE
SERIAL NUMBER WHEN
ORDERING PARTS

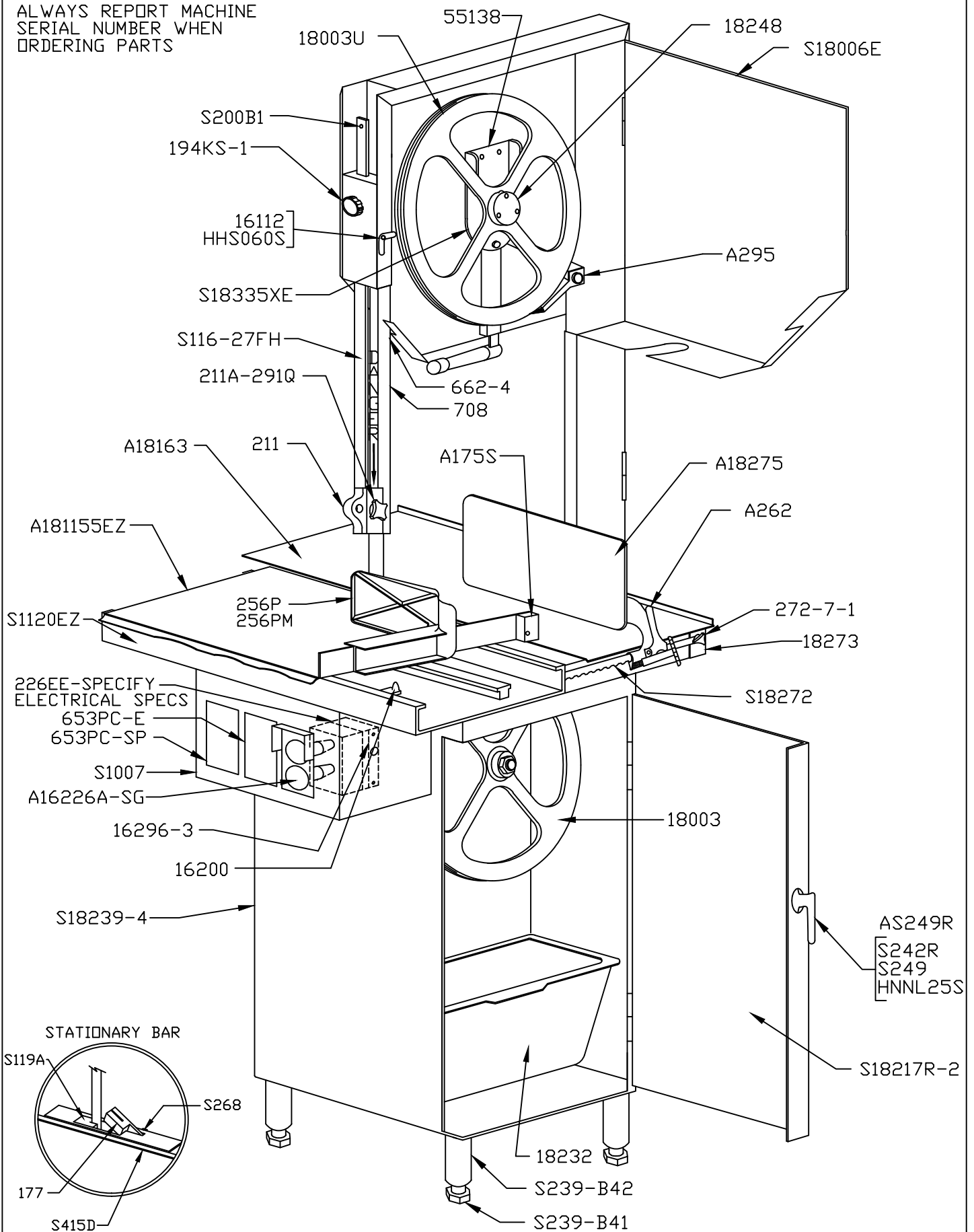

SPLIT PLATTER ASSEMBLY

NOTE:
ALWAYS REPORT MACHINE
SERIAL NUMBER WHEN
ORDERING PARTS

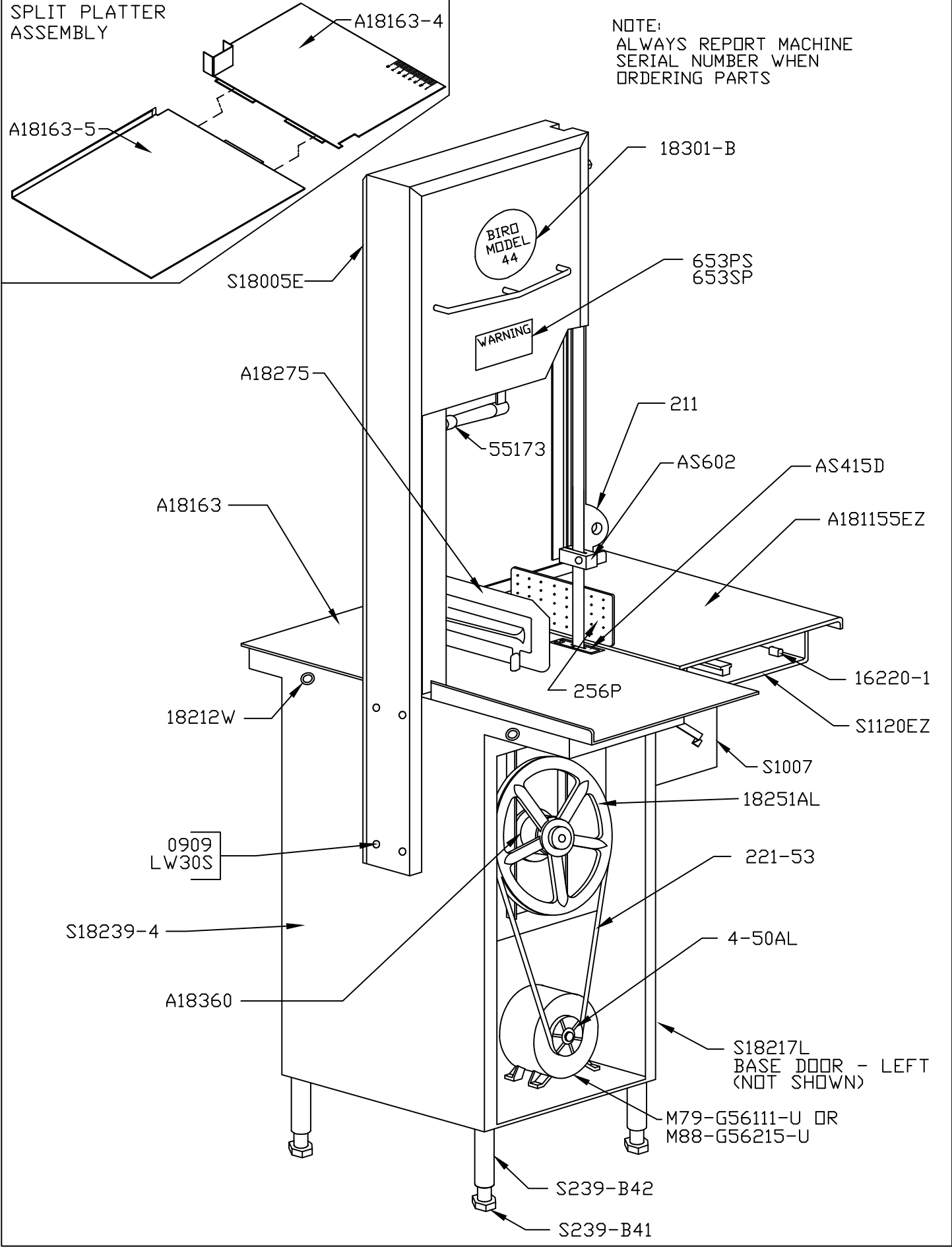

**MODEL 44 FIXED HEAD
BLADE TENSION ASSEMBLY**

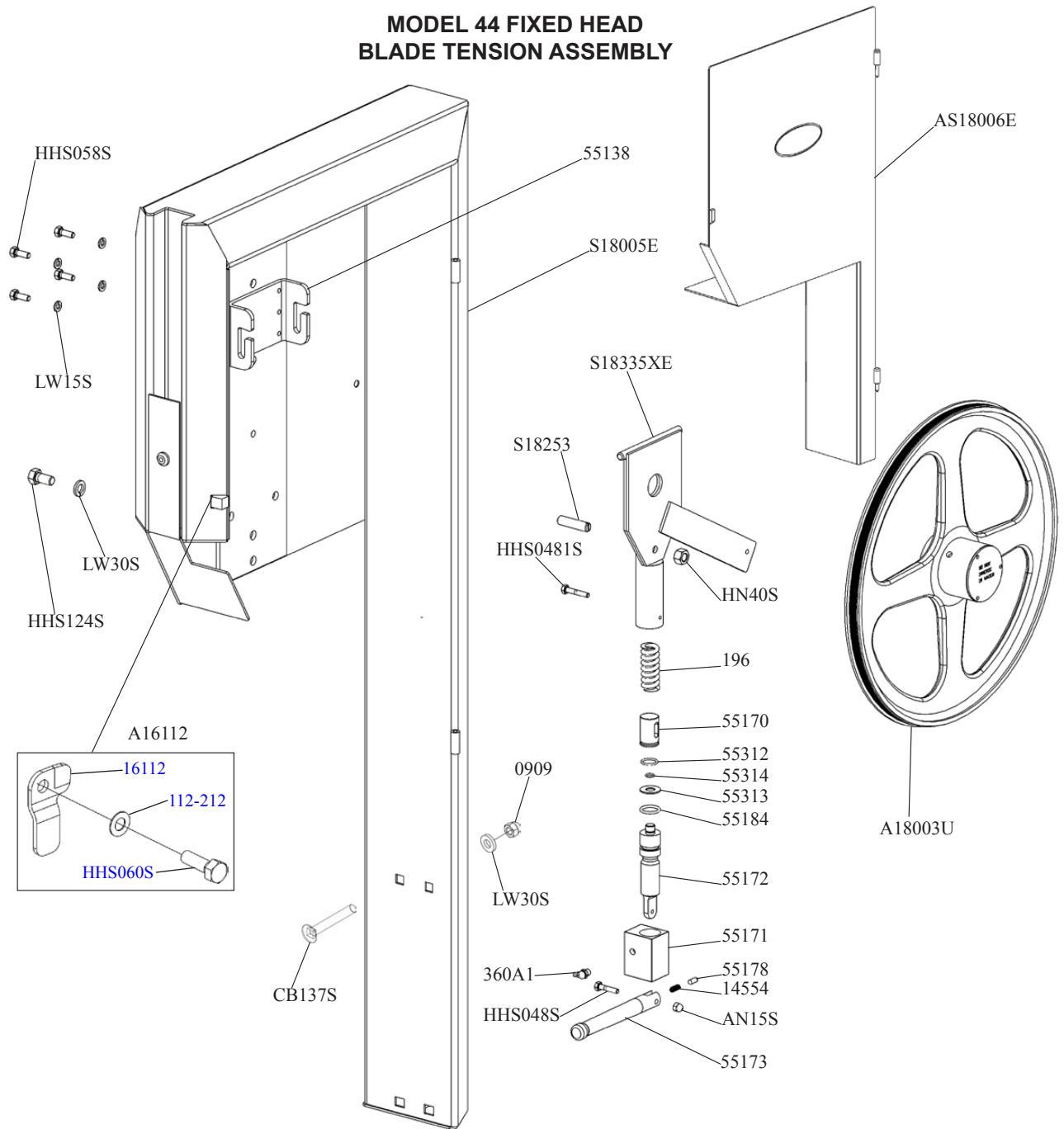

Item No.	Description
AS18005E	Head and Door Assembly, SS Fixed
AS18006E	Head Door Assembly, SS Fixed
AN15S	Acorn nut, 1/4-20, SS
A16122	Head door latch assembly
A18003U	Upper wheel assembly, 18 inch
CB137S	Carriage bolt, 1/2-13 x 3 1/2, SS
HHS0481S	Hex head screw, 1/4-20 x 1 1/2, SS
HHS048S	Hex head screw, 1/4-20 x 1 1/4, SS
HHS058S	Hex head screw, 5/16-18 x 7/8, SS
HHS060S	Hex head screw, 5/16-18 x 1, SS
HHS124S	Hex head screw, 1/2-13 x 7/8, SS
HN40S	Hex nut, 1/2-13 light jam, SS
LW15S	Lock washer, 5/16, SS
LW30S	Lock washer, 1/2, SS
S18005E	Head, SS Fixed
S18253	Upper wheel aligning screw, SS
S18335XE	Upper wheel hinge plate, SS Fixed

Item No.	Description
0909	Acorn nut, 1/2-13, SS
112-212	Compression washer, 2 1/64 ID x 5/8 OD, SS
14554	Spring
16112	Head door latch, SS
196	Saw tension spring
360A1	Grease fitting
55138	Hinge bracket, upper wheel
55170	Blade tension cap gauge
55171	Blade tension adjustment housing
55172	Blade tension screw
55173	Blade tension adjustment handle
55178	Plunger pin
55184	O-ring, blade tension screw
55312	O-ring for tension cap gauge
55313	Plastic washer - tension screw
55314	O-ring, plastic washer

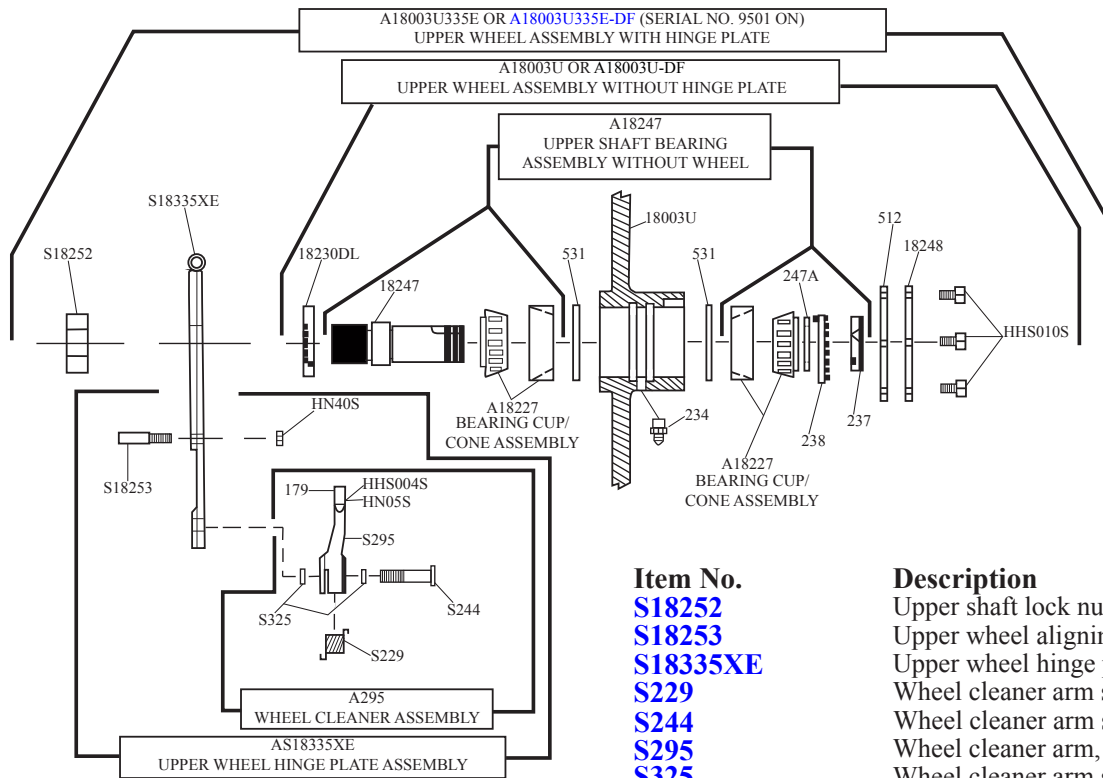

Item No.
A18003U
A18003U335E
A18227
A18247
AS18335XE
A295
HHS004S
HHS010S
HN05S
HN40S

Description
 Upper wheel assembly w/o hinge plate
 Upper wheel assembly w/ hinge plate, FH
 Bearing cup/cone assembly
 Upper shaft and bearing assembly
 Upper wheel hinge plate assembly
 Wheel cleaner assembly
 Hex head screw, 8-32 x 3/8, SS
 Hex head screw, 10-32 x 3/8, SS
 Hex nut, 8-32, SS
 Hex nut, 1/2-13, SS

Item No.
S18252
S18253
S18335XE
S229
S244
S295
S325
179
18003U
18230DL
18247
18248
234
237
238
247A
512
531

Description
 Upper shaft lock nut
 Upper wheel aligning screw, SS
 Upper wheel hinge plate
 Wheel cleaner arm spring, SS
 Wheel cleaner arm stud, SS
 Wheel cleaner arm, SS
 Wheel cleaner arm stud washer, SS
 Wheel cleaner
 Upper wheel, 18"
 Upper shaft seal, double lip
 Upper shaft
 Upper wheel hub cap
 Grease fitting
 Upper shaft castellated lock nut
 Upper shaft castellated lock nut washer
 Upper shaft bearing back-up washer
 Upper wheel hub cap gasket
 Retaining ring (2 req.)

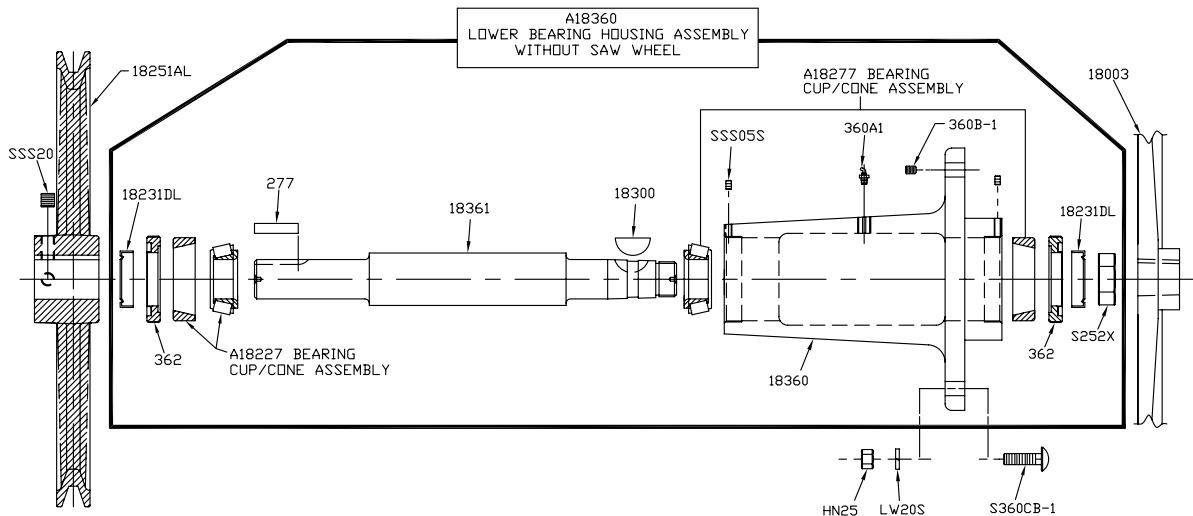

Item No.
A18227
A18360
HN25S
LW20S
SSS05S
SSS20
S252X
S360CB-1
18003

Description
 Bearing cup/cone assembly
 Lower bearing housing assembly
 Hex nut, 3/8-16, SS
 Lock washer, 3/8, SS
 Set screw, 10-24 x 3/8, cup point, SS
 Set screw, 3/8-16 x 3/8, cup point
 Shaft lock nut, SS
 Carriage bolt, 3/8-16 x 1 1/4, SS
 Lower wheel, 18"

Item No.
18231DL
18251AL
18300
18360
18361
277
360A1
360B-1
362

Description
 Lower shaft seal, double lip
 Upper V-belt pulley, 12.8 x 1 1/8 AL.
 Lower shaft woodruff key
 Lower bearing housing
 Lower shaft
 Lower shaft pulley key
 Grease fitting
 Set screw, 1/2-13 x 1/2, flat point
 Lower bearing housing adjusting cap

AS415D
STATIONARY BAR ASSEMBLY, SS

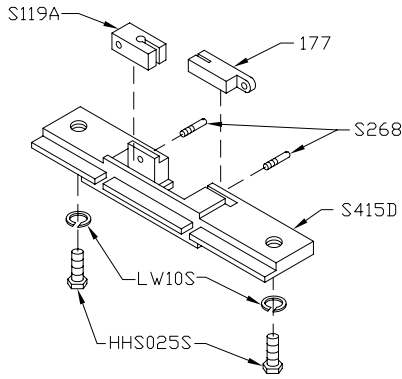

Item No.	Description
AS415D	Stationary bar assembly, SS
HHS025S	Hex head screw, 1/4-20 x 1/2, SS
LW10S	Lock washer, 1/4, SS
S119A	Saw guid in stationary bar, SS
S268	Stationary bar headless screw
S415D	Stationary bar, SS
177	Nylon filler

AS16132
REAR STEEL CLEANER ASSEMBLY, SS

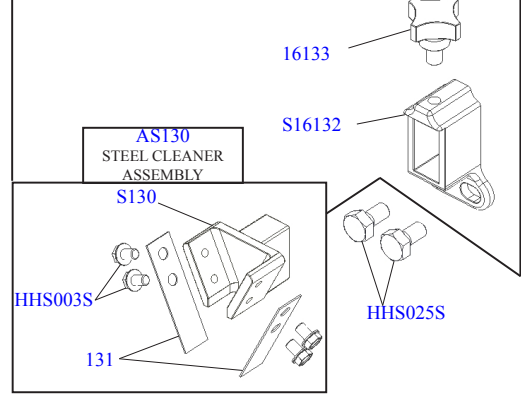

Item No.	Description
AS130	Saw cleaner assembly, SS
AS16132	Rear saw blade cleaner assembly, SS
HHS003S	Hex head screw 8-32 x 1/4", SS
HHS025S	Hex head screw 1/4-20 x 1/2", SS
S130	Saw cleaner bracket, rear, SS
S16132	Saw cleaner bracket holder, rear, SS
131	Saw cleaner, SS
16133	Fastener knob - 4 point

**A18273-275 MEAT GAUGE
GEAR RACK & BRACKET ASSEMBLY**

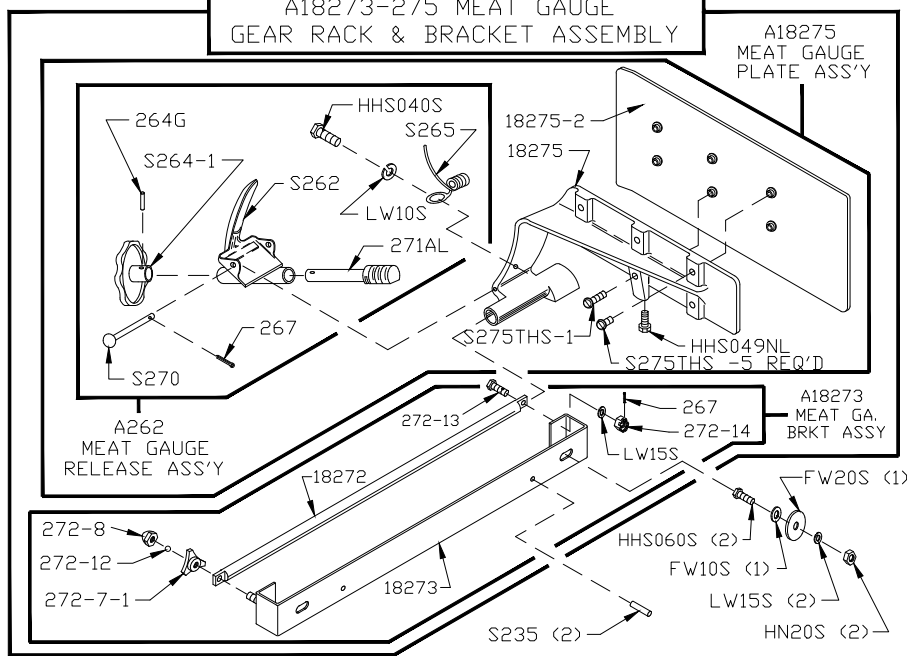

Item No.	Description
A18273-275	Meat gauge gear rack & bracket assembly
A18273	Meat gauge bracket assembly
A18275	Meat gauge plate assembly
A262	Meat gauge release assembly
FW10S	Flat washer, 5/16, SS
FW20S	Fender washer, 5/16 x 1/4, SS
HHS040S	Hex head screw, 1/4-20 x 3/4, SS
HHS049NL	Hex screw - nylon 5/16-18 x 1/2
HHS060S	Hex head screw, 5/16-18 x 1, SS
HN20S	Hex nut, 5/16-18, SS
LW10S	Lock washer, 1/4, SS
LW15S	Lock washer, 5/16, SS
S18272	Meat gauge gear rack
S235	Taper pin, 4 x 3/4, SS
S262	Meat gauge release handle, SS
S264-1	Meat gauge hand wheel, SS

Item No.	Description
S265	Meat gauge release spring, SS
S270	Meat gauge release pin, SS
18273	Meat gauge bracket, Order A18273
18275	Meat gauge arm
18275-2	Meat gauge plate, SS
264G	Meat gauge hand wheel groove pin
264-1S	Hand wheel shim
267	Meat gauge release cotter key
271AL	Meat gauge worm gear
272-7-1	Lock knob, 5/16-18, 3 point
272-8	Cap nut 5/16-18, SS
272-12	Brass ball, 7/32 dia.
272-13	Hex head bolt, 5/16-18 x 1/4, SS
S275THS	Truss head screw, 1/4-20 x 3/8 (5 ea.)
S275THS-1	Truss head screw, 1/4-20 x 1 (1 ea.)

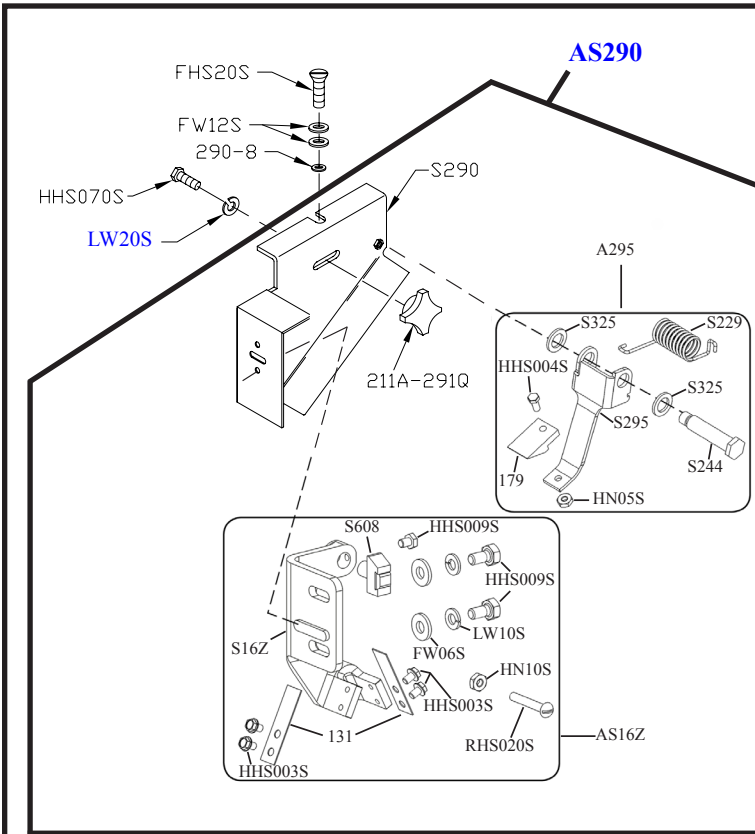

AS290
CLEANING UNIT ASSEMBLY, SS

Item No.	Description
A295	Wheel cleaner assembly
AS16Z	Guide bracket saw cleaner assembly, SS
AS290	Cleaning unit assembly, SS
FHS20S	Flat head screw, 10-32 x 1/2", SS
FW06S	Flat washer, 1/4", SS
HHS003S	Hex head screw, 8-32 x 1/4", SS
HHS004S	Hex head screw, 8-32 x 3/8", SS
HHS009S	Hex head screw, 10-24 x 1/4", SS
HHS070S	Hex head screw, 3/8-16 x 1", SS
HN05S	Hex nut, 8-32, SS
HN10S	Hex nut, 10-32, SS
LW10S	Lock washer, 1/4", SS
LW20S	Lock washer, 3/8", SS
RHS20S	Round head screw, 10-32 x 1 1/8", SS
S16Z	Lower guide bracket saw cleaner holder, SS
S229	Wheel cleaner arm spring, SS
S244	Wheel cleaner arm stud, SS
S290	Cleaning unit stamping, SS
S295	Wheel cleaner arm, SS
S325	Wheel cleaner washer, SS
S608	Saw backup guide w/ #607 carbide
131	Saw cleaner, SS
179	Wheel cleaner
211A-291Q	Fastener knob, 4 point
290-8	Cleaning unit locator washer, SS

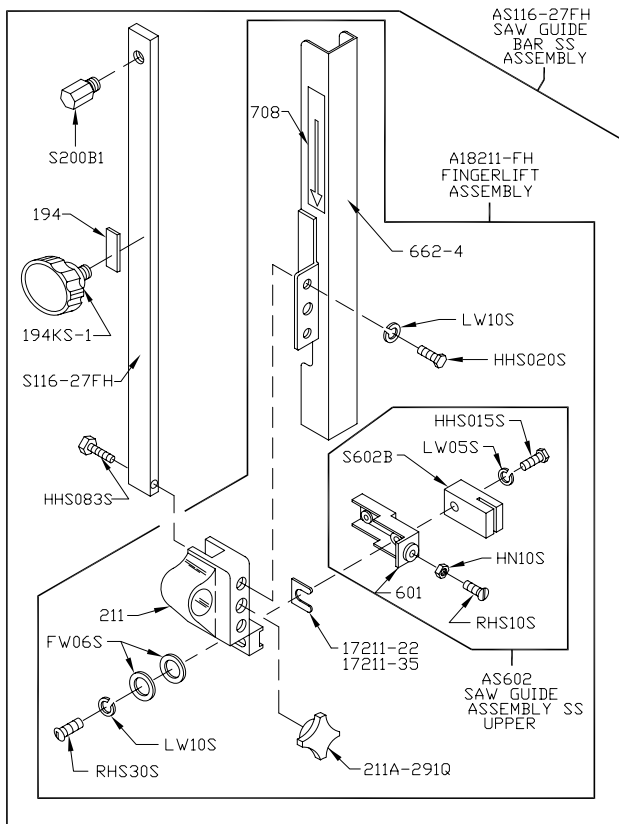

AS116-27FH
SAW GUIDE BAR ASSEMBLY, SS

Item No.	Description
A18211-FH	Fingerlift assembly removable, Fixed Head
AS116-27FH	Saw guide bar assembly SS, 27", Fixed Head
AS602	Saw guide assembly SS, upper
FW06S	Flat washer, 1/4", SS
HHS015S	Hex head screw, 10-32 x 7/8", SS
HHS020S	Hex head screw, 1/4-20 x 3/8", SS
HHS083S	Hex head screw, 3/8-16 x 1 3/4", SS
HN10S	Hex nut, 10-32, SS
LW05S	Lock washer, #10, SS
LW10S	Lock washer, 1/4", SS
RHS10S	Round head screw, 10-32 x 3/4", SS
RHS30S	Round head screw, 1/4-20 x 7/8", SS
S116-27FH	Saw guide bar 27", SS Fixed Head
S200B1	Stop stud on guide bar
S602B	Upper saw guide SS w/ beveled carbide
17211-22	Fingerlift shim, .022
17211-35	Fingerlift shim, .035
194	Saw guide bar lock pad, Brass
194KS-1	Saw guide bar lock knob assembly, Fixed Head
211	Fingerlift bracket
211A-291Q	Fingerlift fastener knob, 4 point
601	Upper saw guide bracket
662-4	Saw guard for stainless head, SS
708	Decal "DANGER EXPOSED BLADE"

A181155EZ
MEAT CARRIAGE ASSEMBLY,
EZ FLOW

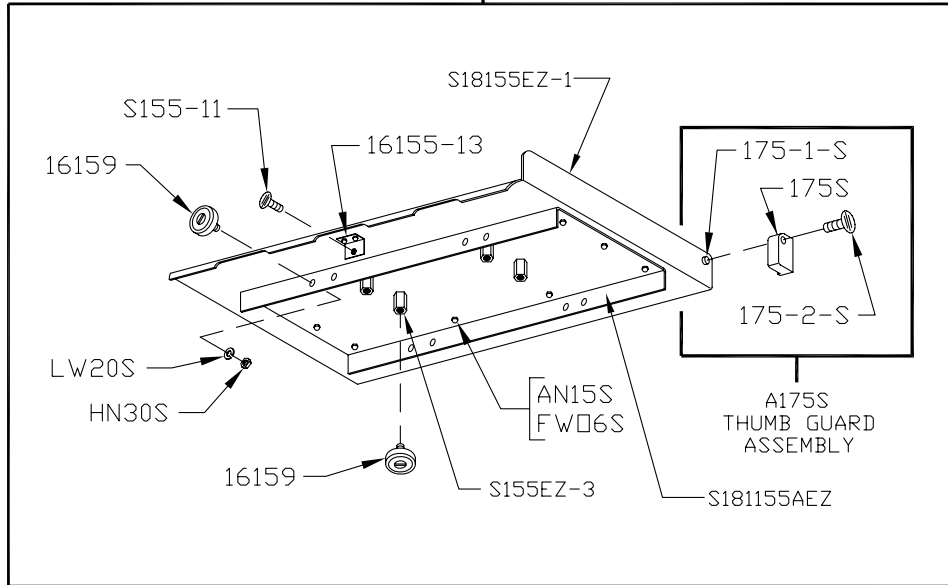

Item No.	Description
A175S	Thumb guard assembly
A181155EZ	Meat carriage assembly, EZ Flow
AN15S	Acorn nut, 1/4-20, SS
FW06S	Flat washer, 1/4, SS
HN30S	Hex nut, 3/8-16, SS
LW20S	Lock washer, 3/8, SS
S155-11	Carriage stop thumb stud, SS
S155EZ-3	Hex stand-off

Item No.	Description
S181155AEZ	Carriage bearing angle plate, (NSS)
S18155EZ-1	Carriage top w/ weld studs
16155-13	Carriage stop angle, SS
16159	Carriage bearing, SS
175S	Thumb guard, Nylon
175-1-S	Thumb guard nut, SS
175-2-S	Thumb screw 1/4-20 x 1/2, SS

A18155EZCE
OPTIONAL MEAT CARRIAGE ASSEMBLY, EZ
FLOW, CE

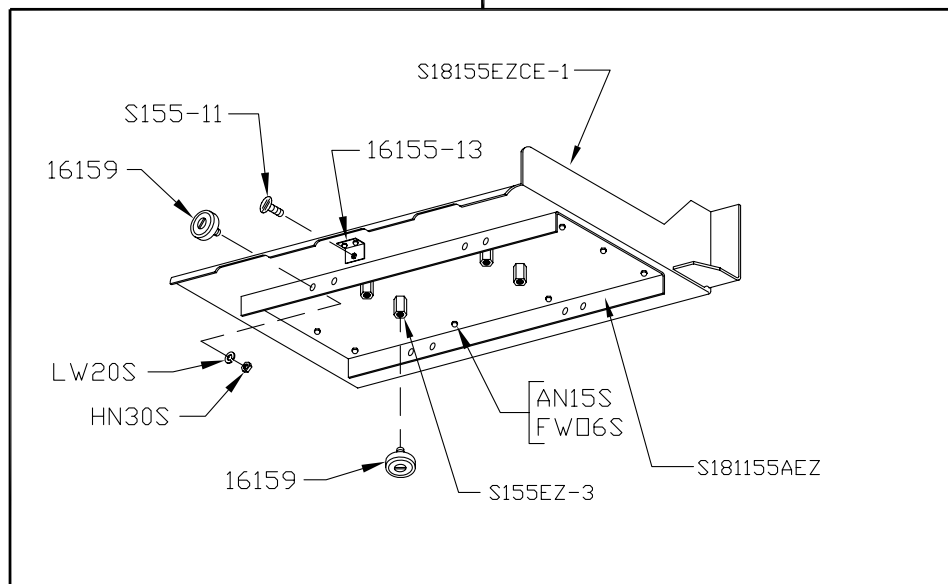

Item No.	Description
A18155EZCE	Meat carriage assembly, EZ Flow
AN15S	Acorn nut, 1/4-20, SS
FW06S	Flat washer, 1/4, SS
HN30S	Hex nut, 3/8-16, SS
LW20S	Lock washer, 3/8, SS
S155-11	Carriage stop thumb stud, SS

Item No.	Description
S155EZ-3	Hex stand-off
S181155AEZ	Carriage bearing angle plate, (NSS)
S18155EZCE-1	Carriage top w/ weld studs
16155-13	Carriage stop angle, SS
16159	Carriage bearing, SS

AS1120EZ
CHANNEL ASSEMBLY,
EZ FLOW

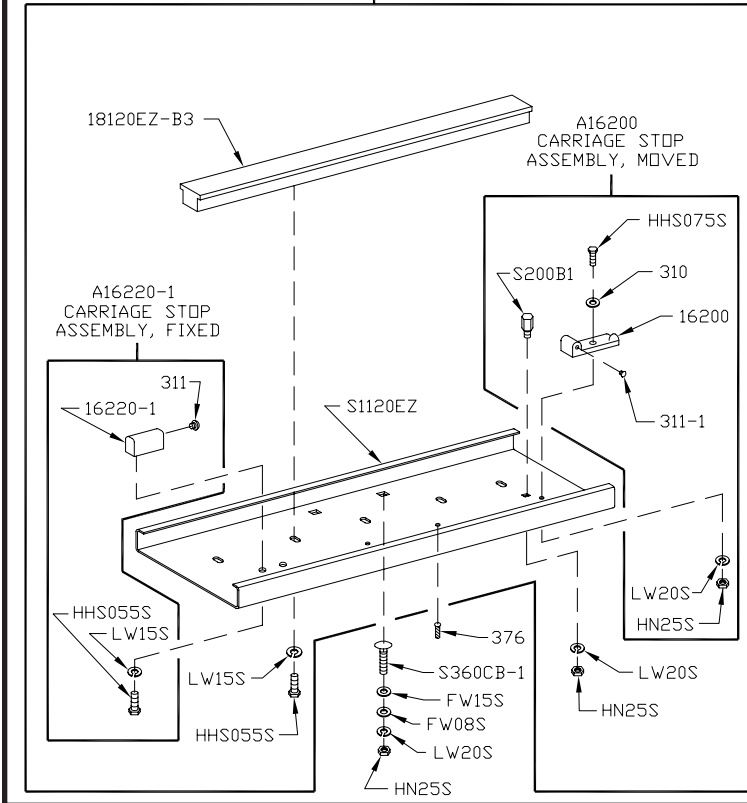

Item No.	Description
A16200	Channel stop assembly, movable
A16220-1	Channel stop assembly, fixed
AS1120EZ	Channel assembly, EZ Flow
FW08S	Flat washer, 3/8 SS
FW15S	Flat washer, 1/2 SS
HHS055S	Hex head screw, 5/16-18 x 3/4, SS
HHS075S	Hex head screw, 3/8-16 x 1 1/4, SS
HN25S	Hex nut, 3/8-16, SS
LW15S	Lock washer, 5/16, SS
LW20S	Lock washer, 3/8, SS
S1120EZ	Channel, 38 1/2", SS
S200B1	Carriage stop stud, SS
S360CB-1	Carriage bolt, 3/8-16 x 1 1/4, SS
16200	Carriage stop, movable
16220-1	Carriage stop, fixed
18120EZ-B3	Guide bar, EZ Flow, T-shaped
310	Waved washer
311	Rubber bumper for fixed stop
311-1	Rubber bumper for movable stop
376	Drive screw, #10 x 1/2, SS

OPERATOR'S NOTES

A609AAW-18 SWITCH ASSEMBLY

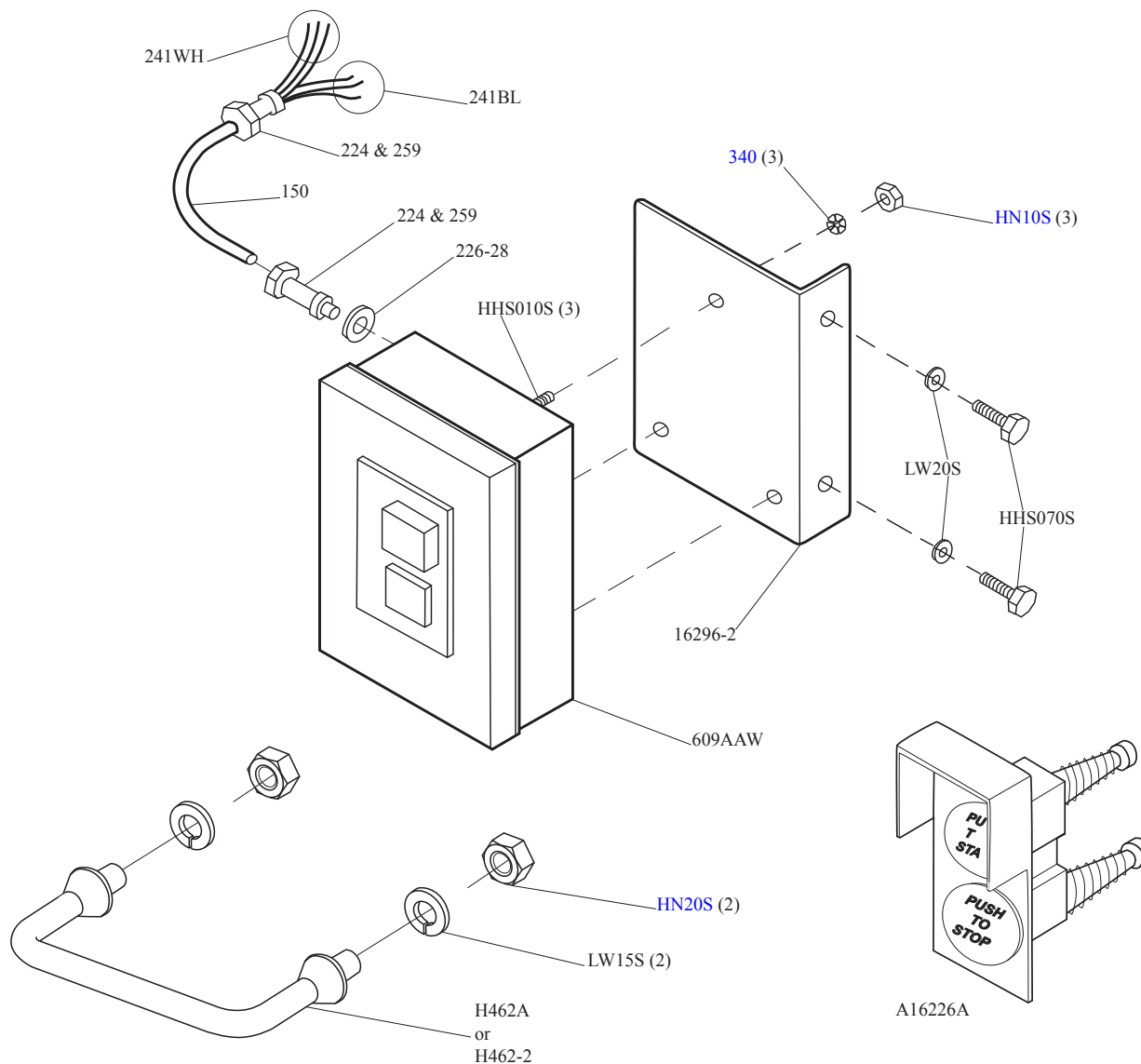

Item No.	Description
A16226A	Green/red switch button assembly w/ springs
A609AAW-18	Switch assembly, 1 & 3 ph, less heater coils
H462-2	Guard for switch
H462A	Guard assembly for switch
HHS010S	Hex head screw, 10-32 x 3/8", SS
HHS070S	Hex head screw, 3/8-16 x 1, SS
HN10S	Hex nut, 10-32, SS
HN20S	Hex nut, 5/16-18, SS
LW15S	Lock washer, 5/16, SS
LW20S	Lock washer, 3/8, SS
150	Conduit, 1/2"
16296-2	Switch bracket SS
224	Conduit connector, 180 °
226-28	Washer SS, 1 1/2 x 27/32
241BL	Wire, black, 12GA., CSA & UL
241WH	Wire, white, 12GA., CSA & UL
259	Anti-Short Bushing, 1/2"
340	Star lock washer
609AAW	Manual switch, size 0, 1 & 3ph

609AAW
WIRING SCHEMATIC

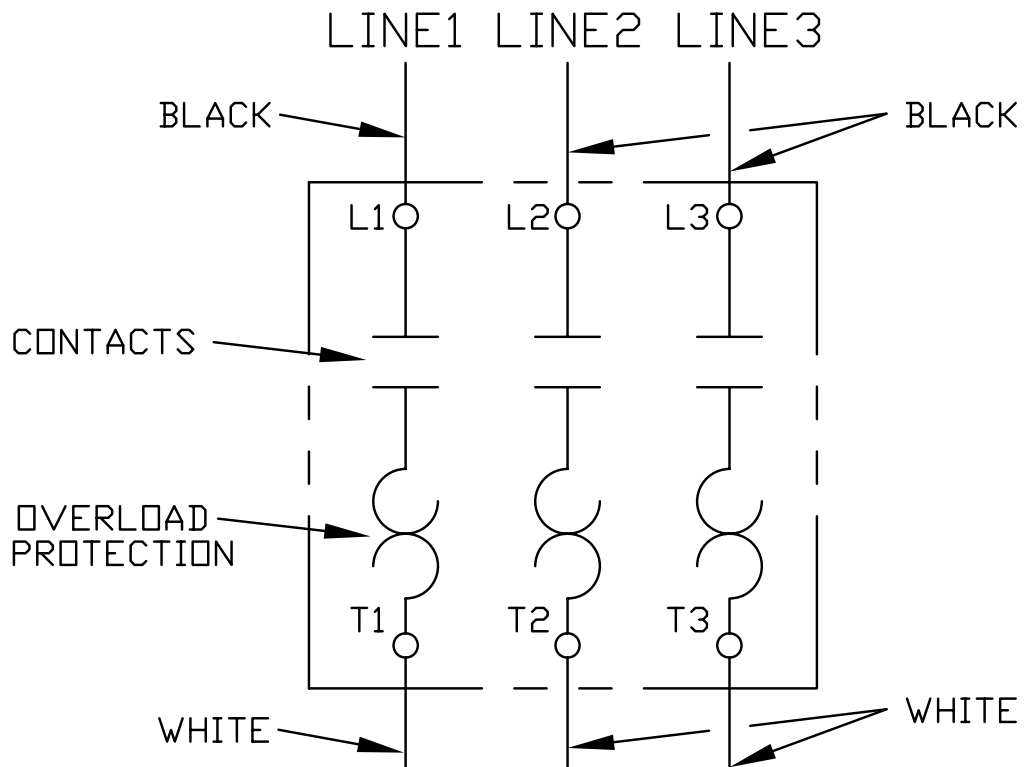

WATERTIGHT MAGNETIC SWITCH ASSEMBLIES (AEG)

INCLUDES MOUNTING BRACKET AND WIRES

Item No.	Description	Item No.	Description
A22618EE-522	BAEG/PC-PB/C14 3HP, 208-220-50/60-3	A22618EE-540	BAEG/MS-PB/C18 5HP, 208/230-50/60-3
A22618EE-534	BAEG/MS-PB/05-E6.3 3HP, 440/460-60-3	A22618EE-544	BAEG/MS-PB/05-E8 5HP, 440/460-60-3
A22618EE-536	BAEG/MS-PB/05-D8 3HP, 380/415-50-3	A22618EE-546	BAEG/MS-PB/05-D14 5HP, 380/415-50-3
A22618EE-538	BAEG/MS-PB/05-F4.7 3HP, 550/575-60-3	A22618EE-548	BAEG/MS-PB/05-F8 5HP, 550/575-60-3

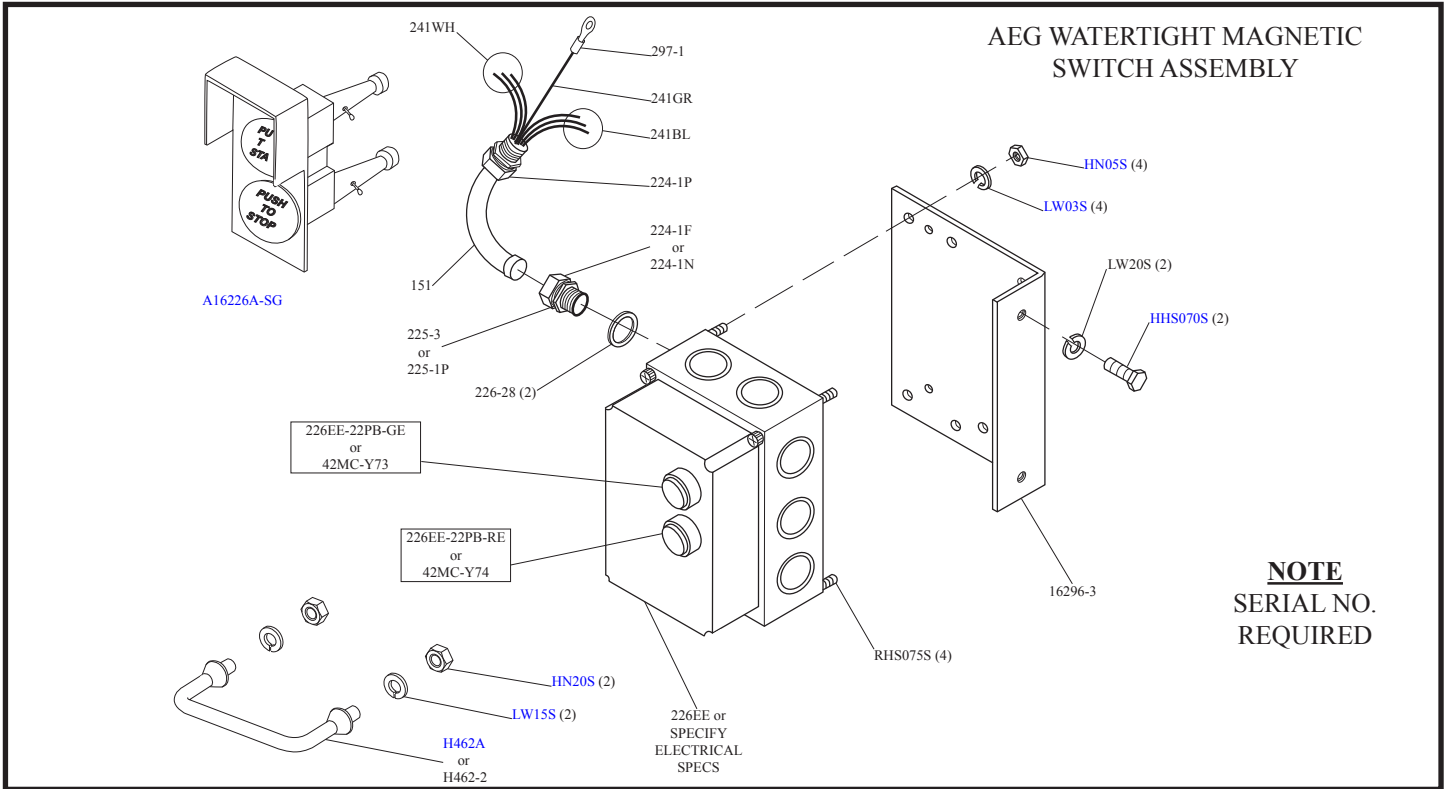

Item No.	Description	Item No.	Description
A16226A-SG	Green/red switch button assembly	226EE-548	BAEG/MS-PB/05-F8 5HP 550-60-3
H462-2	Guard for switch	226EE-548K	Contact, Overload, subplate replcmnt 550V,3PH,5HP
H462A	Guard assembly for switch	226EE-CO	Contact, LS05.10-CO, 208-230V
HHS070S	Hex head screw, 3/8-16 x 1, SS	226EE-CO11K	Contact, LS11K.11S-CO, 208-230V
HN05S	Hex nut, 8-32, SS	226EE-DO	Contact, LS05.10-DO, 380-415V
HN20S	Hex nut, 5/16-18 SS	226EE-ENCL-PB22	Enclosure w/ 22mm Pushbutton holes
LW03S	Lock washer, #8, SS	226EE-ENCL-PB30	Enclosure w/ 30mm Pushbutton holes
LW15S	Lock washer, 5/16, Heavy, SS	226EE-EO	Contact, LS05.10-EO, 440-480V
LW20S	Lock washer, 3/8, Heavy, SS	226EE-EO11K	Contact, LS11K.11S-EO, 480V, 60HZ-380V,50HZ
RHS075S	Round head screw, 8-32 x 3/4, SS	226EE-FO	Contact, LS05.10-FO, 550V
151	Watertight conduit	226EE-FO11K	Contact, LS11K.11S-FO, 575V
16296-3	Switch bracket SS AEG/VYNCKIER Encl.	226EE-OL4I	Overload, B18K-I, 2.5-4A
224-1P	Conduit connector, 180°	H281EE-51	Overload, B18K, 4-6.3A
226EE-522	BAEG/MS-PB/05-C14 3HP 230-50/60-3	226EE-OL06.3K	Overload, B05-K, 4-6.3A
226EE-522K	Contact, Overload, subplate replcmnt 220V,3PH,3HP	226EE-OL08L	Overload, B05-L, 5.5-8A
226EE-534	BAEG/MS-PB/05-E6.3 3HP 440-60-3	226EE-OL08.5L	Overload, B18K-L, 5.5-8.5A
226EE-534K	Contact, Overload, subplate replcmnt 440V,3PH,3HP	226EE-OL12M	Overload, B18K-M, 8-12A
226EE-536	BAEG/MS-PB/05-D8 3HP 380-50-3	226EE-OL14NN	Overload, B05-NN, 10-14A
226EE-536K	Contact, Overload, subplate replcmnt 380V,3PH,3HP	226EE-OL18O	Overload, B18K-O, 14.5-18A
226EE-538	BAEG/MS-PB/05-F4.7 3HP 550-60-3	226-28	Washer, 1-1/2 x 27/32, SS
226EE-538K	Contact, Overload, subplate replcmnt 550V,3PH,3HP	241BL	Wire, black, 12GA., CSA & UL
226EE-539	BAEG/MS-PB/05-A4.7 3HP 550/110-60-3	241GR	Wire, green, 12GA., CSA & UL
226EE-540	BAEG/MS-PB/C18 5HP 220-60-3	241RD	Wire, red, 12GA., CSA & UL
226EE-540K	Contact, Overload, subplate replcmnt 220V,3PH,5HP	241WH	Wire, white, 12GA., CSA & UL
226EE-544	BAEG/MS-PB/C18 5HP 440-60-3	42MC-Y73	Start button, green, 30mm
226EE-544K	Contact, Overload, subplate replcmnt 440V,3PH,5HP	42MC-Y74	Stop button, red, 30mm
226EE-546	BAEG/MS-PB/D14 5HP 380/415-50-3	226EE-22PB-GE	Start button, green, 22mm
226EE-546K	Contact, Overload, subplate replcmnt 380V,3PH,5HP	226EE-22PB-RE	Stop button, red, 22mm

**MODEL 44SSFH SCHEMATIC USING 3PH AEG W.T. SWITCH
FOR 220/380/440 VOLTS, THREE PHASE, 60 CYCLE BALDOR MOTOR**

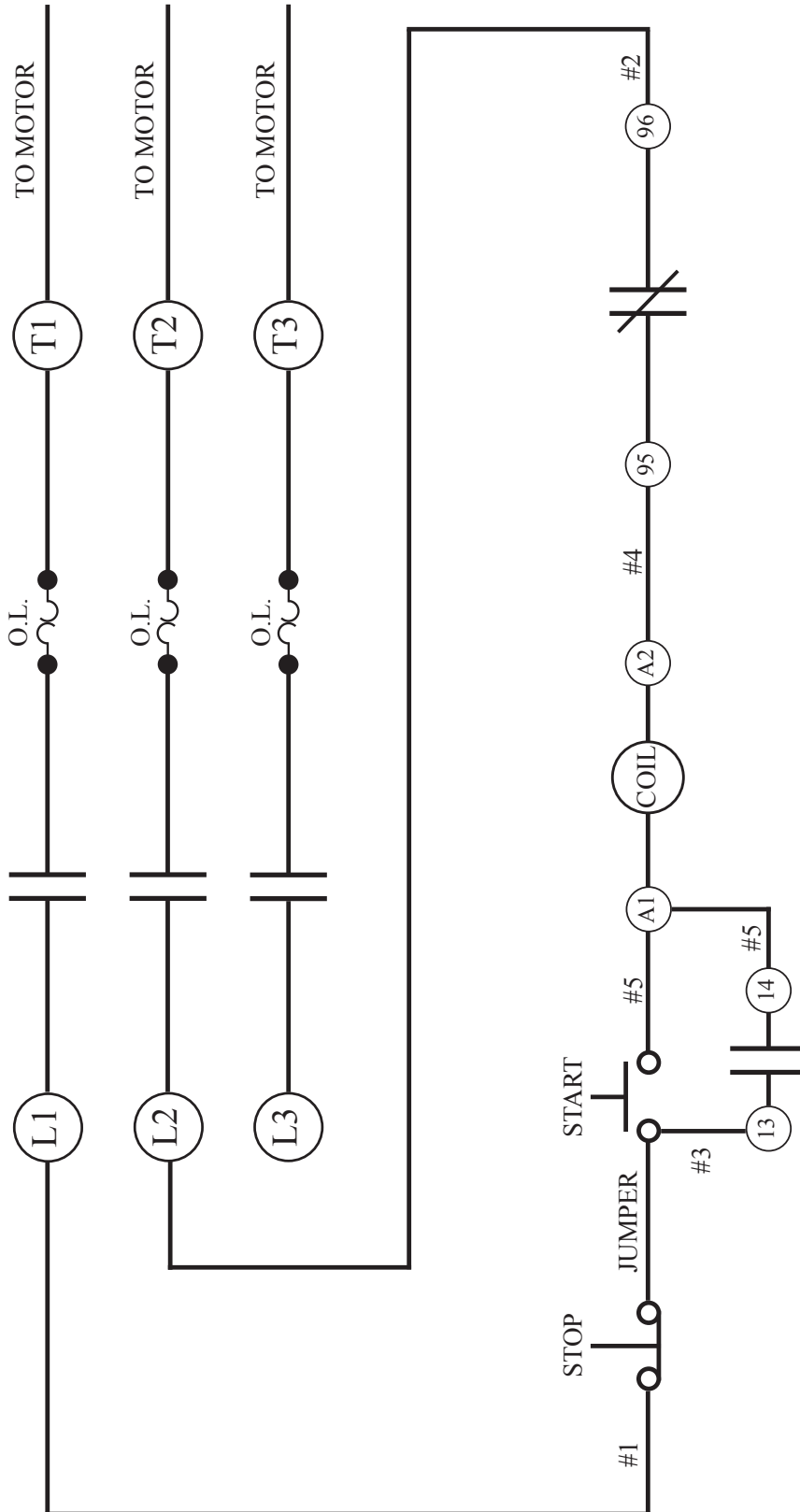

OPERATOR'S NOTES

**WEARABLE SAW PARTS THAT WILL FIT
BIRO MODEL 44SSFH**



Item No. **S130**
SAW CLEANER BRACKET



*Item No. **131**
STEEL BLADE CLEANER



*Item No. **S119A**
LOWER SAW GUIDE

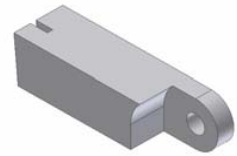

*Item No. **177**
NYLON FILLER

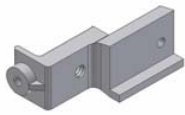

Item No. **601**
UPPER SAW GUIDE BRACKET



*Item No. **S602B**
UPPER SAW GUIDE
W/ BEVELED CARBIDE



*Item No. **S265**
MEAT GAUGE SPRING

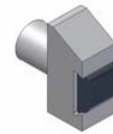

*Item No. **S608**
LOWER BLADE BACKUP
W/ CARBIDE



*Item No. **S268**
FILLER & GUIDE STUD

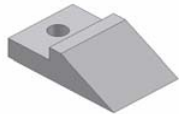

*Item No. **179**
WHEEL CLEANER



*Item No. **S244**
WHEEL CLEANER ARM STUD



*Item No. **S229**
WHEEL CLEANER
ARM SPRING



Item No. **S295**
WHEEL CLEANER ARM

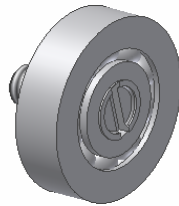

Item No. **16159**
CARRIAGE BEARING

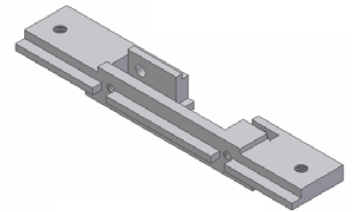

Item No. **S415D**
STAINLESS STATIONARY BAR



NOT TO SCALE



USE PARTS REPAIR KIT PART NO. 18700FH

*** included in repair kit.**

MODEL 44SSFH PART NUMBERS AND DESCRIPTIONS
PROVIDE MODEL AND SERIAL NO. WHEN ORDERING PARTS

MOTOR SECTION		Item No.	Description
Item No.	Description		
M79-G56111-U	Motor, 3HP, 208/220/440-50/60-3 open	S229	Wheel cleaner arm spring, SS
M88-G56215-U	Motor, 5HP, 220/440-60-3 moisture resistant	S235	Taper pin, #4 x ¾, SS
Item No.	Description	S242R	Base door lock right, SS
AN15S	Acorn nut, ¼-20 SS	S244	Wheel cleaner arm stud, SS
CB137S	Carriage bolt, ½-13 x 3½, SS	S249	Base door handle, SS
FHS20S	Flat head screw, 10-32 x ½, SS	S252X	Shaft lock nut, SS
FW06S	Flat washer, ¼, SS	S262	Meat gauge release handle, SS
FW08S	Flat washer, ⅜, SS	S264-1	Meat gauge hand wheel, SS
FW10S	Flat washer, ⅝, SS	S265	Meat gauge release spring, SS
FW15S	Flat washer, ½ SS	S268	Stationary bar headless screw, SS
FW20S	Fender washer, ⅝ x 1¼, SS	S270	Meat gauge release pin w/ holes, SS
HHS010S	Hex head screw, 10-32 x ¾, SS	S275THS	Truss head screw, ¼-20 x ¾, SS
HHS020S	Hex head screw, ¼-20 x ¾, SS	S275THS-1	Truss head screw, ¼-20 x 1, SS
HHS035S	Hex head screw, ¼-20 x ⅝, SS	S290	Cleaning unit stamping, SS
HHS0481S	Hex head screw, ¼-20 x 1½, SS	S295	Wheel cleaner arm, SS
HHS048S	Hex head screw, ¼-20 x 1¼, SS	S360CB-1	Carriage bolt ⅜-16 x 1¼, SS
HHS055S	Hex head screw, ⅝-16 x ¾, SS	S415D	Stationary bar, SS
HHS058S	Hex head screw, ⅝-16 x ⅞, SS	S602B	Upper saw guide, SS
HHS060S	Hex head screw, ⅝-16 x 1, SS	S608	Saw back up guide w/ #607 carbide, SS
HHS067S	Hex head screw, ⅜-16 x ¾, SS	SSS15S	Set screw, ⅝-16 x ⅝, SS cup point
HHS070S	Hex head screw, ⅜-16 x 1, SS	0909	Acorn nut, ½-13, SS
HHS075S	Hex head screw, ⅜-16 x 1¼, SS	112-212	Compression washer 21/64 I.D.
HHS083S	Hex head cap screw, ⅜-16 x 1¾, SS	116KS	Lock knob w/ SS threaded stud
HHS124S	Hex head screw, ½-13 x ⅞, SS	131	Saw cleaner, SS
HN05S	Hex nut, 8-32, SS	14554	Compression spring, SS
HN20S	Hex nut, ¼-20, SS	151	Conduit, watertight- Sold per inch
HN25S	Hex nut, ⅜-16, SS Nylok, jam	16112	Head door latch, SS
HN30S	Hex nut, ⅜-16, SS Light jam	16133	Fastener knob - 4 point
HN40S	Hex nut, ½-13, SS	16155-13	Carriage stop angle, SS
HNNL25S	Hex nut, ⅜-16, Nylok, jam	16159	Meat carriage bearing, SS
LW03S	Lock washer, #8, SS	16200	Carriage stop movable
LW10S	Lock washer, ¼, SS	16220-1	Carriage stop fixed, Al
LW15S	Lock washer, ⅝, SS	16296-3	Switch bracket, AEG/Vynckier enclosure
LW20S	Lock washer, ⅜, SS	175-1-S	Thumb guard nut, SS
LW30S	Lock washer, ½, SS	175-2-S	Thumb screw, ¼-20 x ½ long, SS
RHS074S	Round head screw, 8-32 x ⅝, SS	175S	Thumb guard, Nylon
RHS30S	Round head screw, ¼-20 x ⅞, SS	177	Stationary bar nylon filler
S1007	Channel bracket, SS	179	Wheel cleaner
S1120EZ	Channel (for center guide), SS	18003	Saw wheel 18", lower
S116-27FH	Saw guide bar, SS Fixed head	18003U	Saw wheel 18", upper
S119A	Saw guide, SS	18120EZ-B3	Guide bar, EZ Flow, T-shaped
S130	Saw cleaner bracket, SS	18212W	Platter rod, SS
S155-11	Meat carriage stop thumb screw, SS	18230DL	Upper shaft seal, Double lip
S155EZ-3	Standoff, easy flow carriage	18231DL	Lower shaft seal, Double lip
S16132	Saw cleaner bracket holder, rear, SS	18232	Scrap bucket
S16Z	Lower guide bracket saw cleaner holder, SS	18247	Upper shaft
S18005E	Head SS, Fixed	18248	Upper wheel hub cap, 12 Ga.(.105) Thk.
S18006E	Head door SS, Fixed- Use AS18006E	18251AL	Pulley, upper V-belt, 12.8 x 1⅞, Al.
S18155EZ-1	Carriage top w/ weld studs	18275	Meat gauge arm
S18217L	Base door left, SS #2051 on	18275-2	Meat gauge plate w/o arm, SS
S18217R-2	RH base door, barrel hinges, SS	18300	Lower shaft woodruff key
S18252	Upper shaft lock nut, SS	18313-371	Operating manual, Mod 44SSFH
S18253	Upper wheel aligning screw, SS	18360	Lower bearing housing
S18272	Meat guage gear rack, SS	18361	Lower shaft
S18335XE	Upper wheel hinge plate SS, Fixed	194	Saw guide bar lock pad, Brass
S200B1	Stop stud guide bar & carriage stop, SS	194KS-1	Saw guide bar lock knob assembly, Fixed Hd.
		196	Saw tension spring

MODEL 44SSFH PART NUMBERS AND DESCRIPTIONS (Cont.)

Item No.	Description	Item No.	Description
211	Finger lift bracket	324	Motor shim, 1/16"
211A-291Q	Finger lift fastener knob, 4-point	324A	Motor shim, 1/8"
212CP	Cotter pin, 1/8 x 3/4, SS	360A1	Lower bearing housing angle grease fitting
221-53	V-belt, 53 Inch	360B-2	Lower bearing housing tilt set screw
224-1P	Conduit connector, Wt. 180 Deg., Plastic	362	Lower bearing housing cap
226-28	Washer, SS 1/2 x 27/32 Conduit Connector	375	Drive screw, for Name & Model plate
237	Upper shaft castellated lock nut	4-40AL	Pulley, Motor 5 x 1, Al.
238	Upper shaft castellated lock nut washer	4-50AL	Pulley, Motor 6 x 1, Al.
241BL	Wire, Black, 12 Ga., CSA & UL	420	Cleaning brush/ safety block slot, 3/16
241GR	Wire, Green, 12 Ga., CSA & UL	512	Upper wheel hub gasket
241RD	Wire, Red, 12 Ga., CSA & UL	55138	Hinge bracket, Upper Wheel
241WH	Wire, White, 12 Ga., CSA & UL	55170	Blade tension cap gauge
247A	Upper shaft washer	55171	Blade tension adjustment housing
256P	Safety pusher plate, Composition	55172	Blade tension screw
264G	Meat gauge hand wheel groove pin	55173	Blade tension adjustment handle
267	Meat gauge release cotter pin	55178	Plunger pin, Blade tension handle
271AL	Meat gauge worm gear, Al.	55184	O-Ring, Blade tension screw
272-12	Brass ball, 7/32 Dia.	55312	O-Ring, for tension cap gauge
272-13	Hex bolt 5/16-18 x 1 1/4, w/ cotter hole	55313	Plastic washer, Tension screw
272-14	Castle nut, 5/16-18, SS	55314	O-Ring, washer retention, 3/8 x 1/2 x 1/16
272-7-1	Knob, 3-pt. 5/16-18 Brass for Meat Ga.	601	Upper saw guide bracket
272-8	Cap nut, SS 5/16-18 Low crown 9/16 AF	602B	Upper saw guide
277	Lower shaft key	602BFSC	Upper saw guide, narrow, fish
290-8	Cleaning unit locator washer, SS	653PC-E	Warning label, English
297-1	Wire terminal eyelet for 12 Ga. TW Wire	653PC-SP	Warning label, Spanish
302-142HT	Saw blade, 142 in. x 5/8, .022, 3T, HT	662-4	Saw guard, Fixed Head
310	Waved washer, movable carr. stop & Hd/dr lock	706SW	Saw warning notice tag, Orange
311	Rubber bumper for stops	708	Decal, "DANGER EXPOSED BLADE"
311-1	Rubber bumper for #16200 Stop	720	Decal, Blade tension adjustment- Fixed Head

COMPLETE ASSEMBLIES FOR MODEL 44SSFH

Item No.	Description	Item No.	Description
AS1120EZ	Channel assembly, EZ flow, SS	A175S	Thumb guard assembly
AS116-27FH	Saw guide bar assembly, 27", SS	A18003U	Upper wheel assembly w/o hinge plate
AS130	Saw cleaner assembly, SS	A18003U335E	Upper wheel assembly w/ hinge plate
AS16Z	Guide bracket saw cleaner assembly, SS	A181155EZ	Meat carriage assembly, EZ flow
AS16132	Saw cleaner assembly, rear, SS	A18163	Stationary platter assembly
AS18005E	Head & door assembly, Fixed, SS	A18211-FH	Fingerlift assembly, removable
AS18006E	Head door assembly, Fixed, SS	A18227	Main bearing cup/cone assembly, up/lower
AS290	Cleaning unit assembly, SS	A18247	Upper shaft bearing assembly w/o wheel
AS415D	Stationary bar assembly, SS	A18273	Meat gauge bracket assembly
AS602	Saw guide assembly, upper	A18275	Meat gauge plate assembly
A16112	Head door latch assembly	A18360	Lower bearing housing assembly w/o wheel
A16200	Carriage stop assembly, Movable	A18361	Lower shaft bearing assembly
A16220-1	Carriage stop assembly, Fixed	55192	Blade tension assembly

OPERATOR'S NOTES

LIMITED WARRANTY:

WARRANTY: The BIRO Manufacturing Company warrants that Model 44SSFH will be free from defects in material and workmanship under normal use and with recommended service. BIRO will replace defective parts, which are covered by this limited warranty, provided that the defective parts are authorized for return, shipping charges prepaid, to a designated factory for inspection and/or testing.

DURATION OF WARRANTY: The warranty period for all parts covered by this limited warranty is one (1) year from date of Inspection/Demonstration advised on the returned Warranty Registration Card, or eighteen (18) months from original factory ship date, whichever occurs first, except as noted below.

PARTS NOT COVERED BY WARRANTY: The following are **not** covered by this limited warranty: wearable parts on the cleaning system such as wheel cleaners (Item No. 179), saw blade cleaners (Item No. 131) blade backup guides (Item No's. S602B, and S119A), and the nylon filler (Item No. 177). This limited warranty does not apply to machines sold as used, rebuilt, modified, or altered from the original construction in which the machine was shipped from the factory. (WATER CONTAMINATED ELECTRICAL SYSTEMS ARE NOT COVERED UNDER THIS LIMITED WARRANTY.) BIRO is not responsible for electrical connection of equipment, adjustments to switch controls or any other electrical requirements, which must be performed only by a certified electrician. BIRO is not responsible for service charges or labor required to replace any part covered by this limited warranty or for any damages resulting from misuse, abuse, lack of proper or recommended service.

EXCLUSION OF WARRANTIES AND LIMITATION OF REMEDIES: BIRO gives no warranties other than those expressly stated in this limited warranty. THE IMPLIED WARRANTY OF MERCHANTABILITY, THE IMPLIED WARRANTY OF FITNESS FOR PROCESSING FOOD PRODUCTS, AND ALL OTHER IMPLIED WARRANTIES ARE SPECIFICALLY EXCLUDED. BIRO IS NOT LIABLE FOR CONSEQUENTIAL OR INCIDENTAL DAMAGES, EXPENSES, OR LOSSES. THE REMEDIES PROVIDED IN THIS BIRO LIMITED WARRANTY ARE PURCHASER'S SOLE AND EXCLUSIVE REMEDIES AGAINST BIRO.

REGISTRATION CARDS: You must sign, date and complete the warranty registration card supplied with each machine. The warranty card must be returned to The BIRO Manufacturing Company for proper registration. If no warranty card is returned to BIRO, the warranty period will begin from the date the machine was originally shipped from the factory.

HOW TO GET SERVICE:

1. Contact the agency from whom you purchased the machine; or
2. Consult the yellow pages of the phone directory for the nearest authorized dealer; or
3. Contact Biro Manufacturing Company for the nearest authorized service entity in your area.

BIRO MANUFACTURING COMPANY

1114 West Main St.
Marblehead, OH 43440
Ph. 419-798-4451
Fax 419-798-9106
Service@birosaw.com
www.birosaw.com

ITEM No.: 18313-371

PTCT: MD44SSFH-371-6-16-1-B