

BIRO[®]

**MODEL 22 POWER MEAT CUTTER
OPERATING AND SERVICE MANUAL
FROM SERIAL No. 24612 AFTER SANITATION
TO SERIAL No. 35300**

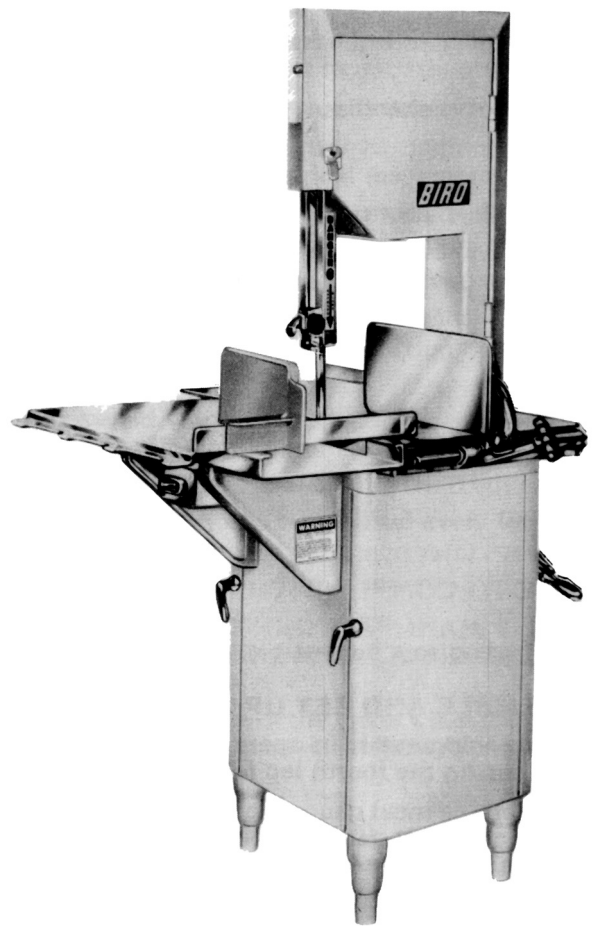
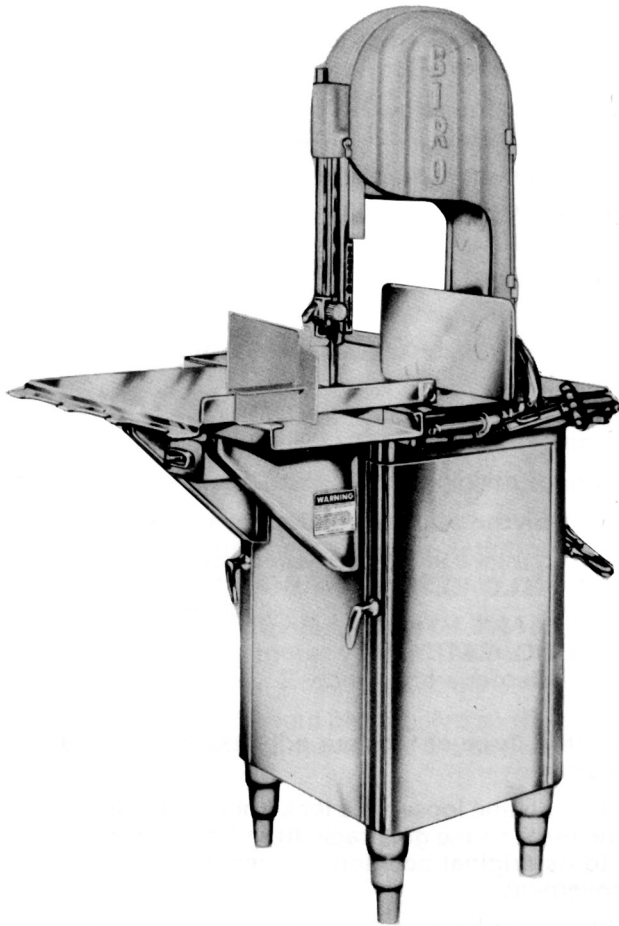

**THE BIRO MANUFACTURING COMPANY
MARBLEHEAD, OHIO 43440-2099 U.S.A.**

E-mail: service@birosaw.com

FAX (419) 798-9106

Phone (419) 798-4451

— NOTES —

MODEL 22 POWER MEAT CUTTER OPERATING AND SERVICE MANUAL

**WARNING TO ALL PURCHASERS, OPERATORS AND OPERATION SUPERVISORS:
FAILURE TO READ AND ADHERE TO THE FOLLOWING IMPORTANT INSTRUCTIONS COULD RESULT IN BODILY INJURY.**

NOTE TO ELECTRICIAN: IF THIS MACHINE IS NOT CORD AND PLUG CONNECTED TO THE ELECTRICAL SUPPLY SOURCE, THEN IT SHOULD BE EQUIPPED WITH, OR CONNECTED TO, A LOCKABLE, MANUALLY-OPERATED DISCONNECT SWITCH (OSHA 1010.147).

- (1) Do not electric wire this power cutter. Have only a qualified and certified electrician wire this power cutter as required. Be sure machine is grounded. Failure to ground this machine could result in electric shock.
 - (2) Do not place machine on sloping floor. Always place machine on flat non-skid floor.
 - (3) Do not use this power cutter for non-food products.
 - (4) Do not use this power cutter to cut pigs feet.
 - (5) Do not attempt to operate this power cutter until this machine has been inspected and demonstrated by the seller – recognized BIRO Representative.
 - (6) Do not attempt to operate this power cutter unless you or the operator has been properly trained. Improper use or operation of this power cutter could result in bodily injury.
 - (7) Do not leave power cutter in operation – unattended.
 - (8) Do not tamper, bypass, remove fixed guards, safety interlock electrical switches or any other safety devices.
 - (9) Do not at any time force feed product through this power cutter.
 - (10) Do not alter or modify this power cutter in any way from its original form. This power cutter in its original form meets the intent of O.S.H.A. applicable standards.
 - (11) Always use safety pusher plate supplied with each power cutter when cutting small product.
 - (12) Do not touch moving blade or moving parts. Never place hand or arm between blade and head column structure.
 - (13) Always disconnect power supply before removing shrouds, removable guards, covers, doors, fences, panels for servicing, cleaning or any other reason.
 - (14) Use only BIRO parts and accessories properly installed, contact your nearest service agency or The BIRO Manufacturing Company for authorized referral assistance.
 - (15) Power cutter operating manuals as supplied with this power cutter are available from BIRO.
- FAILURE TO COMPLY WITH THIS WARNING NOTICE COULD RESULT IN BODILY INJURY.**
THE BIRO MANUFACTURING COMPANY, 1114 WEST MAIN STREET, MARBLEHEAD, OHIO 43440-2099 U.S.A. – PHONE (419) 798-4451 – FAX (419) 798-9106

TO ASSEMBLE AND SET UP CUTTER FOR USE:

- (1) After placing cutter in operational area, it is imperative that three of the four adjustable foot studs be tightened, using the fourth leg for adjustment to level the cutter.
- (2) To assemble meat gauge plate, Item No. 12275, Page 8, to machine loosen the lock knob, Item No. 272-7, on right side of meat gauge bracket. Raise the right side of the meat gauge gear rack, Item 12272, and slip the meat gauge plate over the gear rack, lower gear rack back to its original position, tighten lock knob. Keep gear rack well oiled with food machine oil to insure free movement.
- (3) The aluminum head, Item No. 12005A comes detached from the base. Slip the head into the Gib, Item No. 260, (slide gibs) section of the base. Make sure the Gibs, Item No. 260, (slide gibs) are oiled or greased to insure free mover

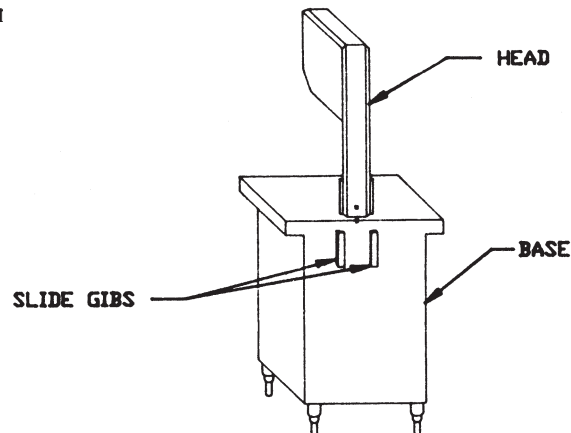

(4) Place upper saw guide assembly on saw guide bar, Item No. 116-18, and fasten in place with finger lift fastener knob, Item No. 211Q.

(5) Placing blade on cutter: Hang upper wheel assembly, Item No. A12003U335 on the upper wheel hinge bracket, Item No. 71-1. Lift up nylon filler, Item No. 177, Page 12. Hang blade on upper wheel and hold blade on wheel with left hand. With the right hand force the back of the blade between the two saw cleaners, Item No. 131, located below the nylon filler, Item No. 177. Lower the nylon filler, Item No. 177, and insert back of blade in upper saw guide slot, Item No. 602B. The blade has already dropped over the lower wheel and is ready for tightening. Press down on ratchet arm, Item No. 10-0, to tighten. Turn wheel one turn to insure proper tracking and tighten to proper tension. When the tension gauge, Item No. 197, located at the bottom of the head becomes tight laterally the blade is at its proper tension, Page 12.

(6) The Side Platter Bracket, Item No. S12214 is packed loose in machine and must be installed on base with supplied hardware and checked for proper adjustment.

(7) The stationary platter, Item No. A12163-1, is placed on top of the base and held in place with two push-pull platter holddown rods, Item No. 12212W, located on the rear rim of the cutter.

(8) The sliding meat carriage table, Item No. A12155, is removed by turning movable stop, Item No. 200, clockwise. After the carriage is in the channel for operation turn movable stop, counter-clockwise, Page 6.

WIRING MOTOR:

(1) Interchange of current is made in motor outlet box. Leads are properly marked. Changing instructions are on motor plate or motor outlet box.

(2) All cutters are wired 220 volts unless otherwise specified. Be sure motor specifications (voltage, cycle, phase) match power supply line. Be sure line voltage is up to specification.

(3) Connect leads to machine in a manner that will be approved by local electrical inspectors.

(4) We recommend not less than No. 12 wire. If leads are too light machine may not have sufficient cutting power and/or speed.

(5) The V-Belt is packed loose in machine to prevent deformation, and must be installed on pulleys at time of wiring motor.

(6) The BIRO Manufacturing Company is not responsible for permanent wiring, connection or installations.

LUBRICATION:

Table Bearings: grease packed at the factory. Repack as necessary.

Meat Gauge Gear Rack: oil daily with food machine oil.

Slide Gibs: for mounting head are provided with grease fittings and should be greased every four months.

Main Bearings: grease packed at factory. Check and grease if necessary.

ADJUSTMENTS:

(1) For tightening motor v-belt: The motor drive belt can be tightened to any desired tension by removal of shims under motor. Recommend approximately $\frac{1}{2}$ " total flex at center of span.

(2) Saw Guides: Should be adjusted so the guide is $\frac{1}{32}$ " from the back edge of the blade when the machine is idling. This prolongs the life of the saw wheels by reducing pressure and wear of the saw blade against the flange of the wheel.

RECOMMENDED SAFE OPERATING PROCEDURES:

(1) Before starting saw, adjust the Saw Guide Bar down to within $\frac{1}{2}$ " of product to be cut.

(2) The 256P Safety End Cut Pusher Plate supplied with every machine as standard equipment, should be used when cutting end cuts of meat.

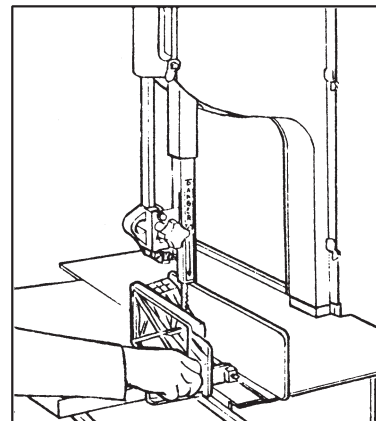
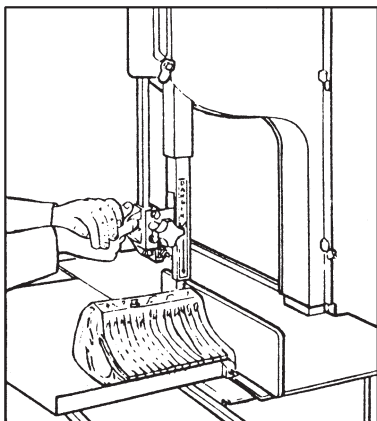

SAW GUIDE BAR SPRING SERVICING PROCEDURE

Item #193 Saw Guide Bar Spring, is located in the head structure on all BIRO Power Meat Saws. The spring is not visible as it is located within the babbitt pocket area.

Dependent upon the frequency of adjustments, that portion of the saw guide bar spring in constant contact with the guide bar will eventually wear. As the spring becomes worn, a loss of tension will cause the finger lift assembly to slide down or not hold the adjusted height setting. When this happens, the saw guide bar spring, Item #193 must be replaced.

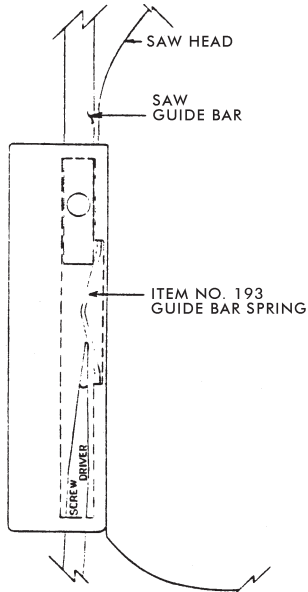

1. Remove the finger lift fastener knob and the finger lift assembly.
2. Remove the finger lift fastener stud.
3. Push the saw guide bar up and out of the top, of the head structure.
4. Remove the saw guide bar spring.
5. Clean and relubricate the babbitt pocket area (the square indented area that seats the saw guide bar spring).
6. Lower the new saw guide bar spring through the top of the babbitt pocket area and guide the spring into position with a standard screwdriver (NOTE: drawing).
7. While holding the saw guide bar spring in position re-enter saw guide bar from the top compressing the saw guide bar spring slightly until the saw guide bar slides past the spring.
8. Replace the finger lift fastener stud, the finger lift assembly and finger lift fastener knob.
9. Test by making several adjustments.

SAW GUIDE BAR AND GUARD SERVICING PROCEDURE

Current Model 22 SAW GUIDE BAR assemblies and GUARDS fit all BIRO Model 22's manufactured.

The factory recommends that when service is performed on any BIRO SAW the servicing agency be sure that the BIRO SAW is equipped with the most current safety features available.

MODEL 22 SAW GUIDE BARS AND SAW GUARDS

All Model 22 Units Prior To Serial Number 25900 (1967)

The SAW GUIDE BAR used on original equipment measured $14\frac{7}{8}$ " long. The (Item #211O/S) FINGER LIFT held the (Item #17-0) SAW GUIDE BEARING BRACKET that held the (Item #228) SAW GUIDE BEARING. The (Item #255) SAW GUARD attached directly to the SAW GUIDE BAR. Any items required for these units should be replaced by (Item #A116-18AL) SAW GUIDE BAR ASSEMBLY, (Item #193) SAW GUIDE BAR SPRING and (Item #660) SAW GUARD ON HEAD DOOR (see adjacent page).

Serial Number 25900 (1967) to serial Number 29423 (1975)

The SAW GUIDE BAR was now drilled across the width. The (Item #255MS) SAW GUARD was now attached to the (Item #211MS) FINGER LIFT. The (Item #17-0) SAW GUIDE BEARING BRACKET and (Item #228) SAW GUIDE BEARING were replaced by the (Item #601) SAW GUIDE BRACKET and the (Item #602B) UPPER SAW GUIDE. When replacing any items on these units the factory recommends the complete UPPER SAW GUIDE BAR ASSEMBLY (Item #A116-18AL) be installed along with a new (Item #193) SAW GUIDE BAR SPRING. The (Item #660) SAW GUARD ON HEAD DOOR (see adjacent page) should be attached to the head door.

Serial Numbers 29423 On (1975 to current)

The SAW GUIDE BAR has been increased to $18\frac{1}{4}$ " and drilled and tapped through the one inch width. The (Item #211MS) FINGER LIFT was redrilled to mate to the (Item #211D) FASTENER STUD. The GUARD (Item #12662-AL) now attaches directly to the FINGER LIFT along with the (Item #601) BRACKET and (Item #602B) GUIDE. The (Item #211Q) FINGER LIFT FASTENER KNOB holds the entire finger lift assembly to the guide bar. The (Item #660) HEAD DOOR GUARD is standard equipment (see adjacent page) and nests with the (Item #12662-AL) GUARD.

Once again, (Item #A116-18AL) UPPER SAW GUIDE BAR ASSEMBLY is currently standard and is applicable to any Model 22 in the field.

The (Item #660) HEAD DOOR GUARD can be attached to all BIRO Model 22 units produced before and after serial number 25900.

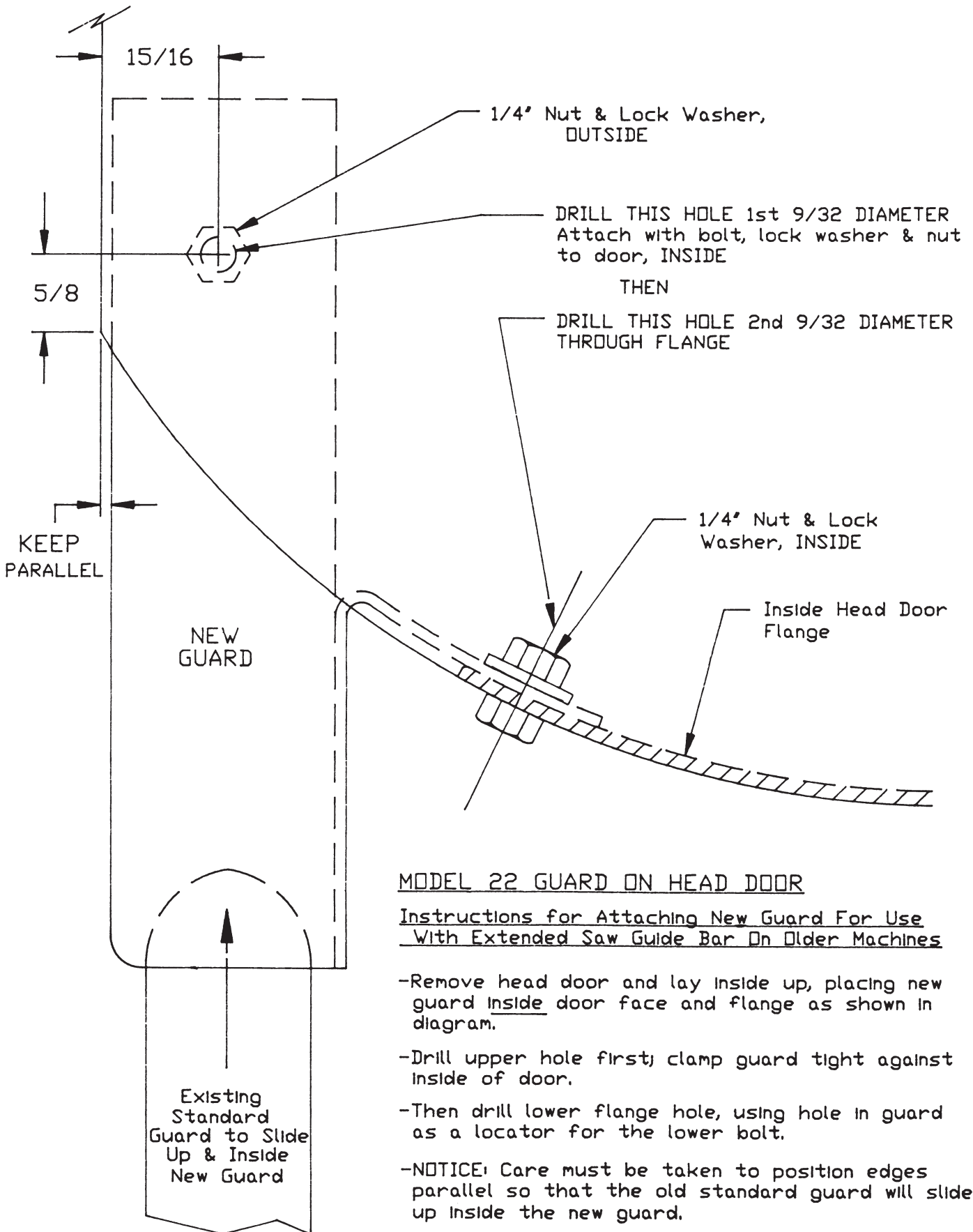

—NOTE—
ALWAYS REPORT MACHINE SERIAL
NO. WHEN ORDERING PARTS.

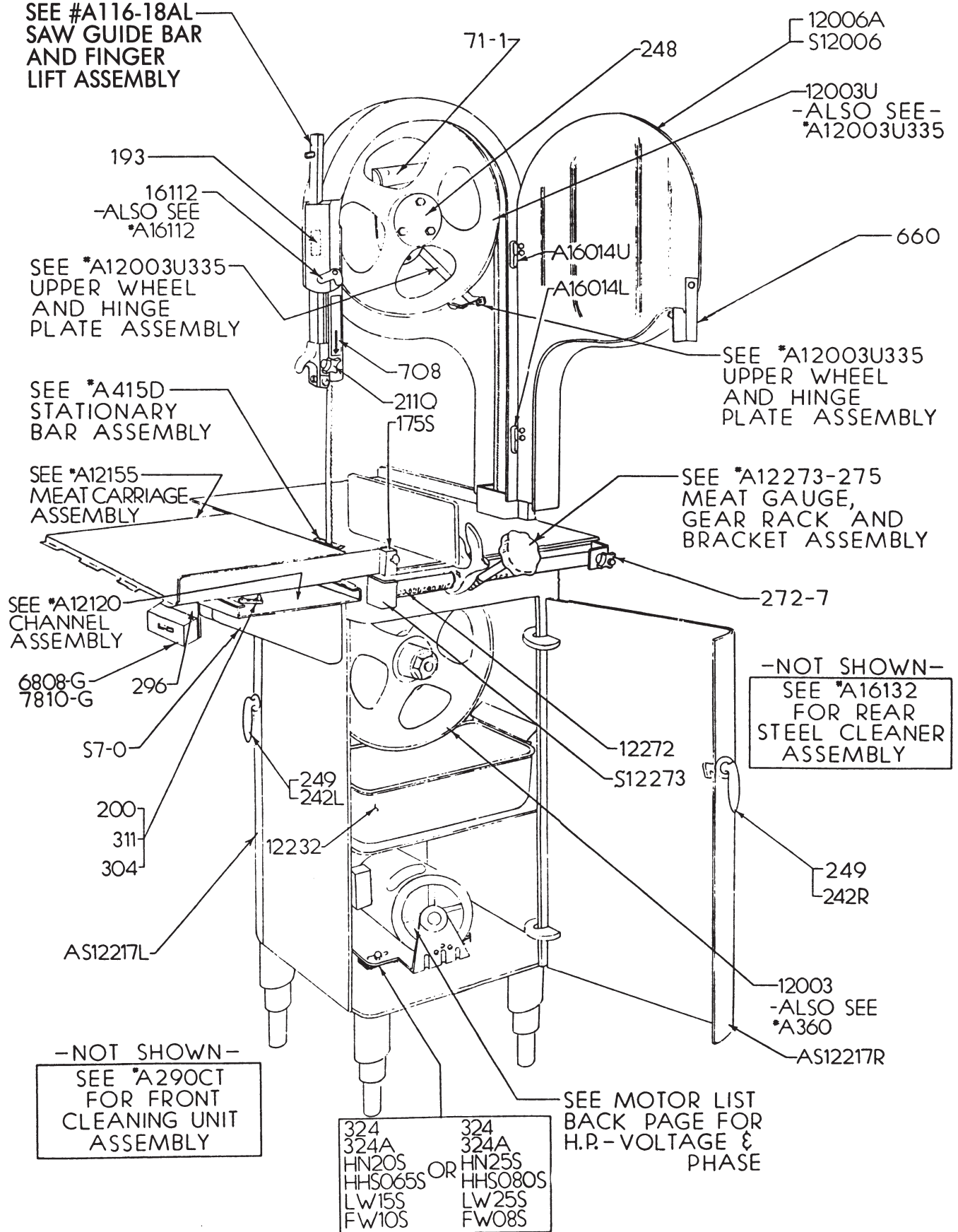

SEE #A116-18AL
SAW GUIDE BAR
AND FINGER
LIFT ASSEMBLY

12006A
S12006

12003U
-ALSO SEE-
*A12003U335

193
16112
-ALSO SEE
*A16112

SEE *A12003U335
UPPER WHEEL
AND HINGE
PLATE ASSEMBLY

SEE *A415D
STATIONARY
BAR ASSEMBLY

SEE *A12155
MEAT CARRIAGE
ASSEMBLY

SEE *A12003U335
UPPER WHEEL
AND HINGE
PLATE ASSEMBLY

SEE *A12273-275
MEAT GAUGE,
GEAR RACK AND
BRACKET ASSEMBLY

SEE *A12120
CHANNEL
ASSEMBLY

-NOT SHOWN-
SEE *A16132
FOR REAR
STEEL CLEANER
ASSEMBLY

6808-G
7810-G

-NOT SHOWN-
SEE *A290CT
FOR FRONT
CLEANING UNIT
ASSEMBLY

SEE MOTOR LIST
BACK PAGE FOR
H.P.- VOLTAGE &
PHASE

324	OR	324
324A		324A
HN20S		HN25S
HHSO65S		HHSO80S
LW15S		LW25S
FW10S		FW08S

—NOTE—
ALWAYS REPORT MACHINE SERIAL
NO. WHEN ORDERING PARTS.

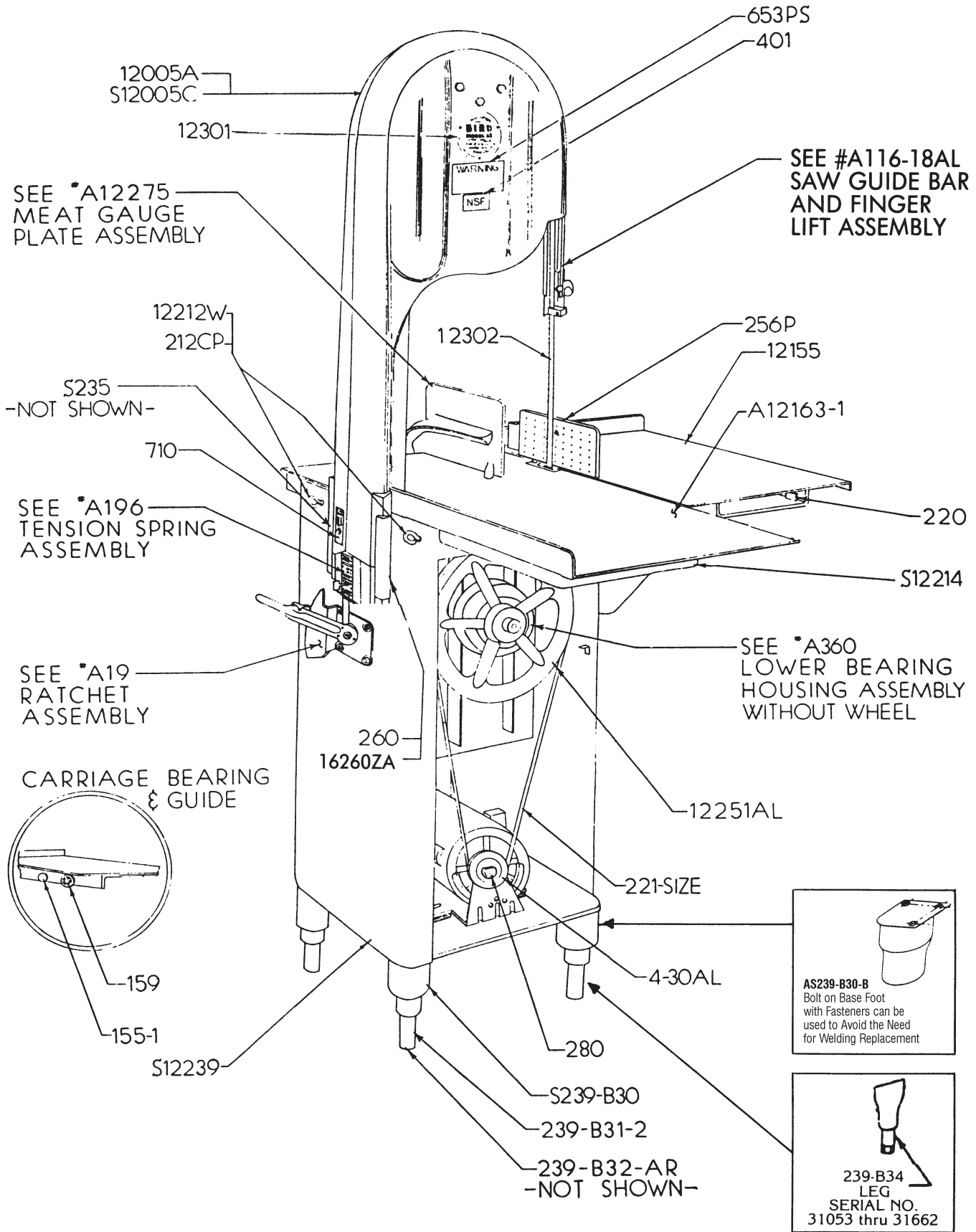

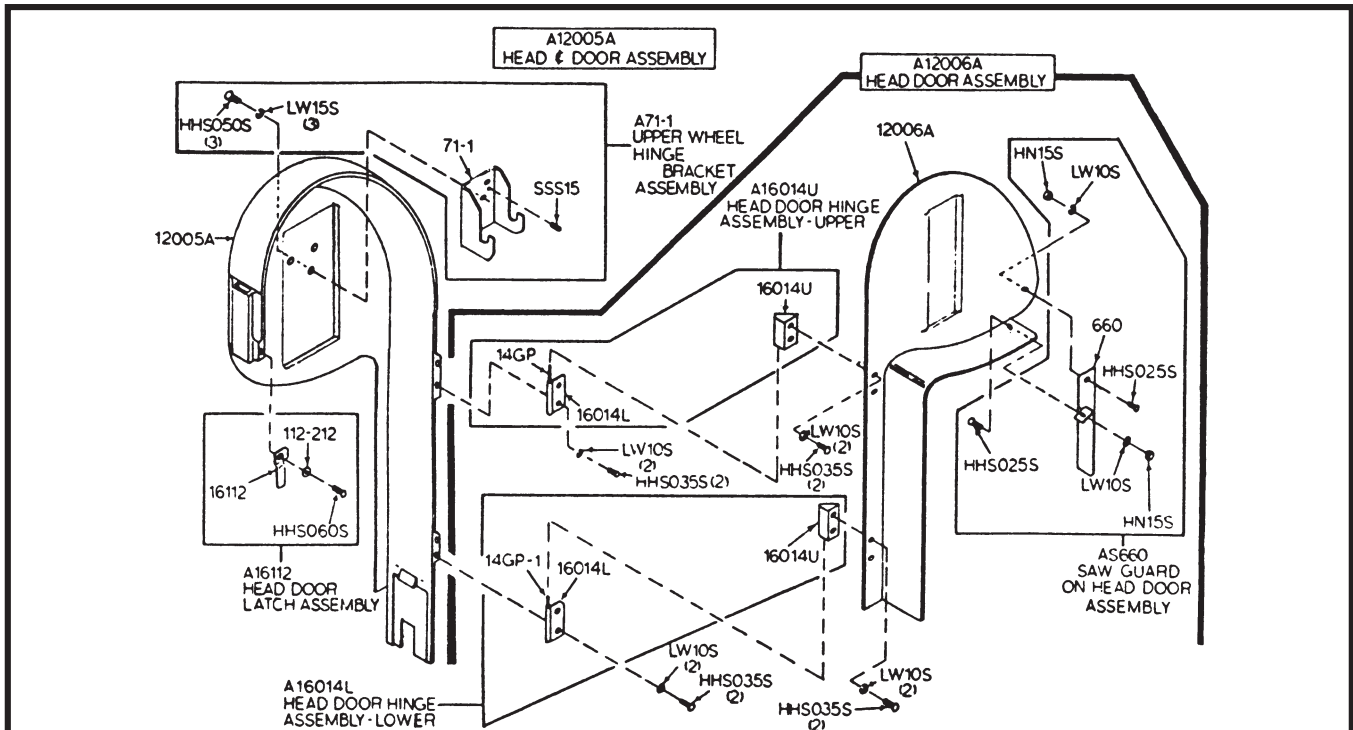

Item No.	Description	Item No.	Description
A12005A	Head & door assembly	LW15S	Lock washer, 5/16 SS
A12006A	Head door assembly	SSS15	Set screw, 5/16-18 x 5/16, cup point, SS
A16014L	Head door hinge assembly, lower	112-212	Waved washer
A16014U	Head door hinge assembly, upper	12005A	Head, new style
A16112	Head door latch assembly	12006A	Head door, new style
A71-1	Upper wheel hinge bracket assembly	14GP	Head door hinge pin, 1 1/2"
AS660	Saw guard on head door assembly	14GP-1	Head door hinge pin, 1/4"
HHS025S	Hex head screw, 1/4-20 x 1/2, SS	16014L	Head door hinge, lower half
HHS035S	Hex head screw, 1/4-20 x 5/8, SS	16014U	Head door hinge, upper half
HHS050S	Hex head screw, 5/16-18 x 5/8, SS	16112	Head door latch
HHS060S	Hex head screw, 5/16-18 x 1, SS	660	Saw guard on head door
HN15S	Hex nut, 1/4-20 SS	71-1	Upper wheel hinge bracket
LW10S	Lock washer, 1/4 SS		

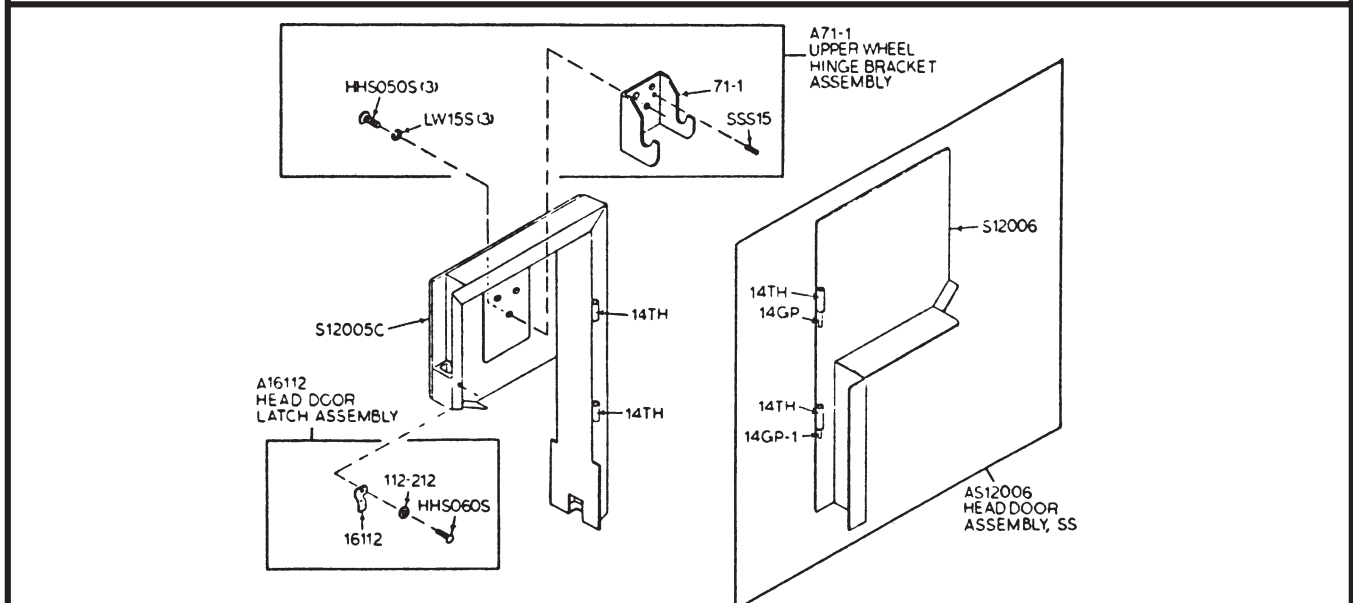

Item No.	Description	Item No.	Description
A16112	Head door latch assembly	SSS15	Set screw, 5/16-18 x 5/16, cup point, SS
AS12005C	Head & door assembly, SS	14TH	Head door hinge, welded
AS12006	Head door assembly, SS	14GP	Head door hinge pin, 1 1/2"
A71-1	Upper wheel hinge bracket assembly	14GP-1	Head door hinge pin, 1/4"
HHS050S	Hex head screw, 5/16-18 x 5/8, SS	112-212	Waved washer
HHS060S	Hex head screw, 5/16-18 x 5/8, SS	16112	Head door latch
LW15S	Lock washer, 5/16, SS	71-1	Upper wheel hinge bracket
S12005C	Head, SS		
S12006	Head door SS		

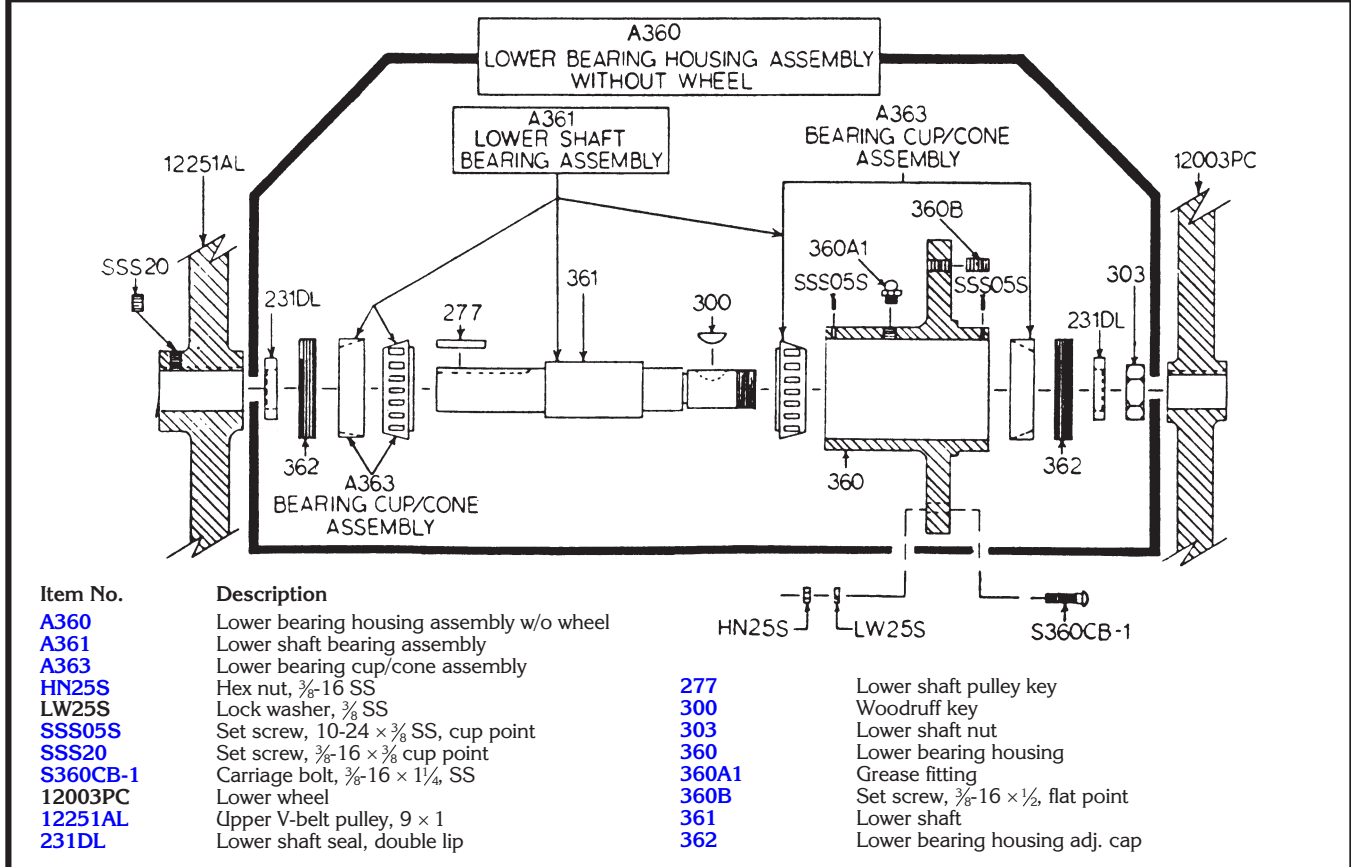
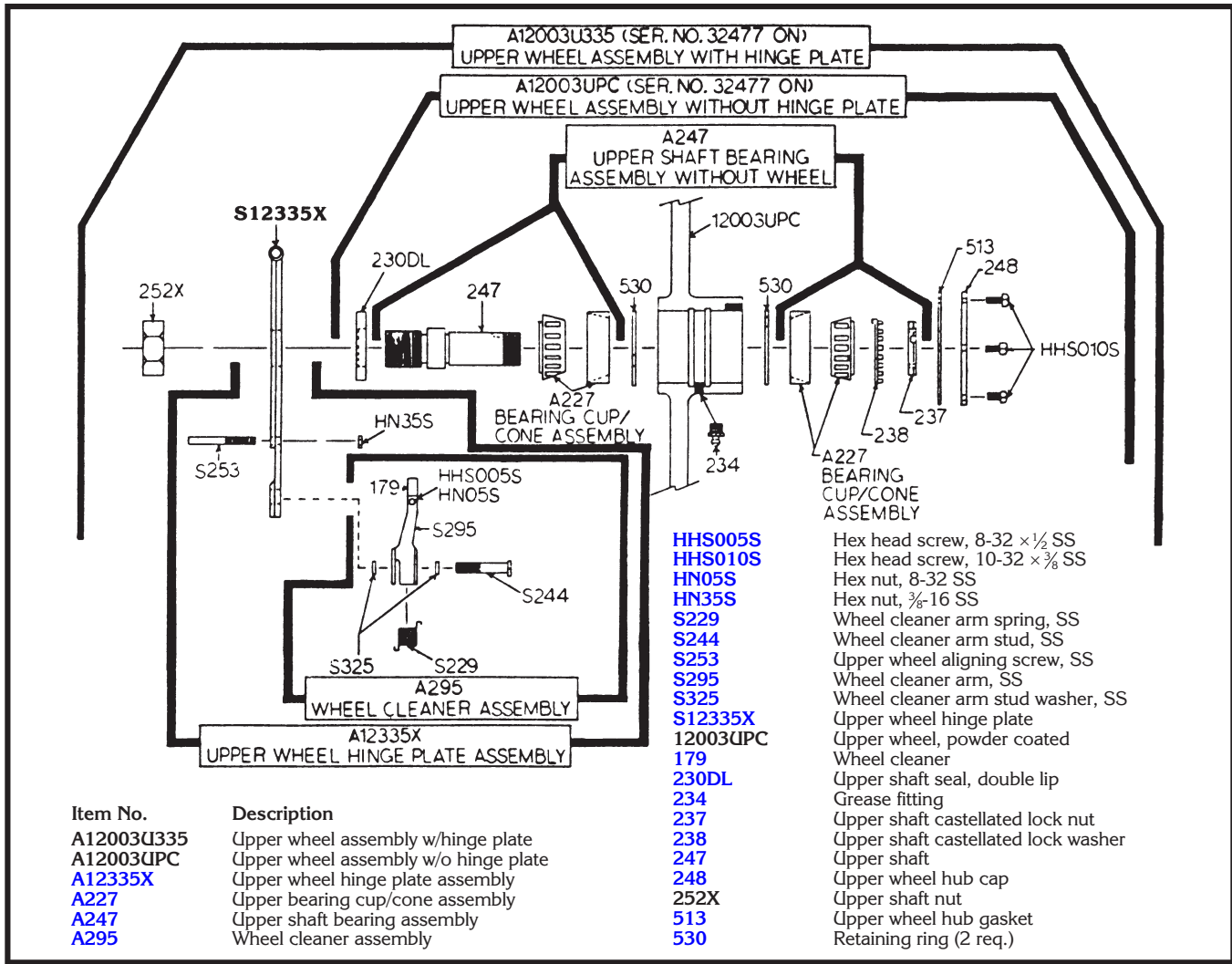

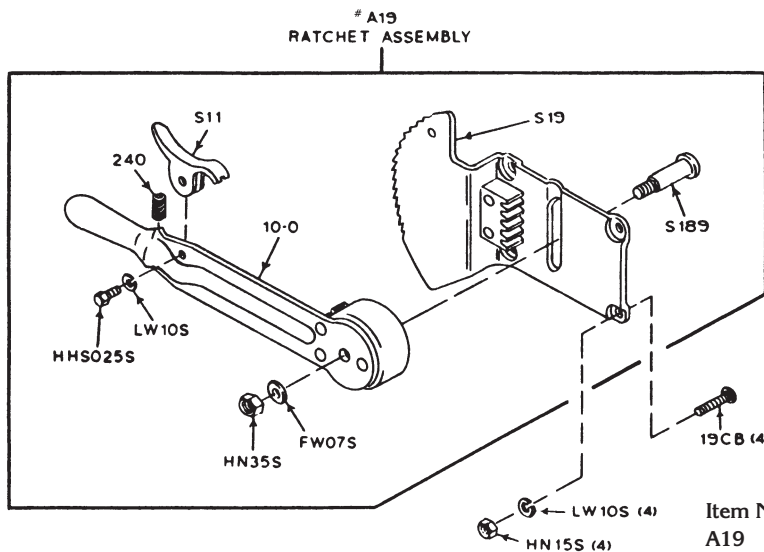

Item No.	Description
A19	Ratchet assembly
FW07S	Flat washer, $\frac{3}{8}$ SS
HHS025S	Hex head screw, $\frac{1}{4}$ -20 \times $\frac{1}{2}$ SS
HN15S	Hex nut, $\frac{1}{4}$ -20 SS
HN35S	Hex nut, $\frac{3}{8}$ -16 SS
LW10S	Lock washer, $\frac{1}{4}$ SS
S11	Ratchet trigger SS
S189	Ratchet arm stud SS
S19	ratchet base SS
10-0	Ratchet arm
19CB	Carriage bolt $\frac{1}{4}$ -20 \times $\frac{3}{4}$ SS
240	Ratchet trigger spring

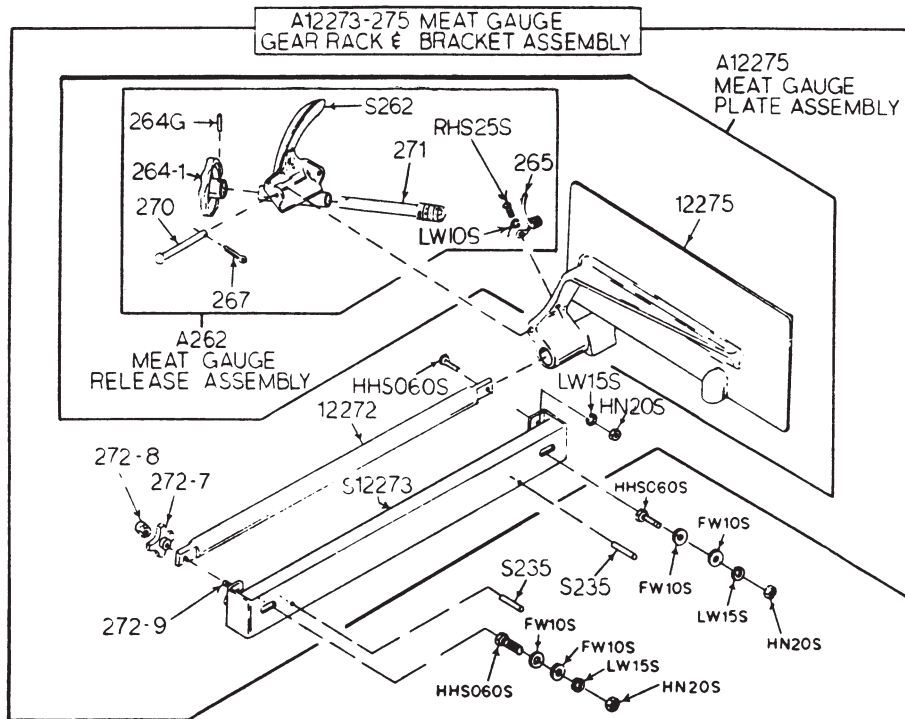

Item No.	Description
A12273-275	Meat gauge assembly
A12275	Meat gauge plate assembly
A262	Meat gauge release assembly
FW10S	Flat washer, $\frac{5}{16}$ SS
HHS060S	Hex head screw, $\frac{5}{16}$ -18 \times 1 SS
HN20S	Hex nut, $\frac{5}{16}$ -18 SS
LW10S	Lock washer, $\frac{1}{4}$ SS
LW15S	Lock washer, $\frac{5}{16}$ SS
RHS25S	Round head screw, $\frac{1}{4}$ -20 \times $\frac{3}{4}$ SS
S12273	Meat gauge bracket, SS
S235	Taper pin, 4 \times $\frac{3}{4}$ SS
S262	Meat gauge release handle, SS

Item No.	Description
12272	Meat gauge gear rack
12275	Meat gauge plate, SS
264G	Meat gauge hand wheel groove pin
264-1	Meat gauge hand wheel
265	Meat gauge release spring
267	Meat gauge release cotter key
270	Meat gauge release pin
271	Meat gauge worm gear
272-7	lock knob, $\frac{5}{16}$ -18, 4 point
272-8	Cap nut, $\frac{5}{16}$ -18 SS
272-9	Hex head screw, $\frac{5}{16}$ -18 \times 2 SS

A290CT
CLEANING UNIT ASSEMBLY

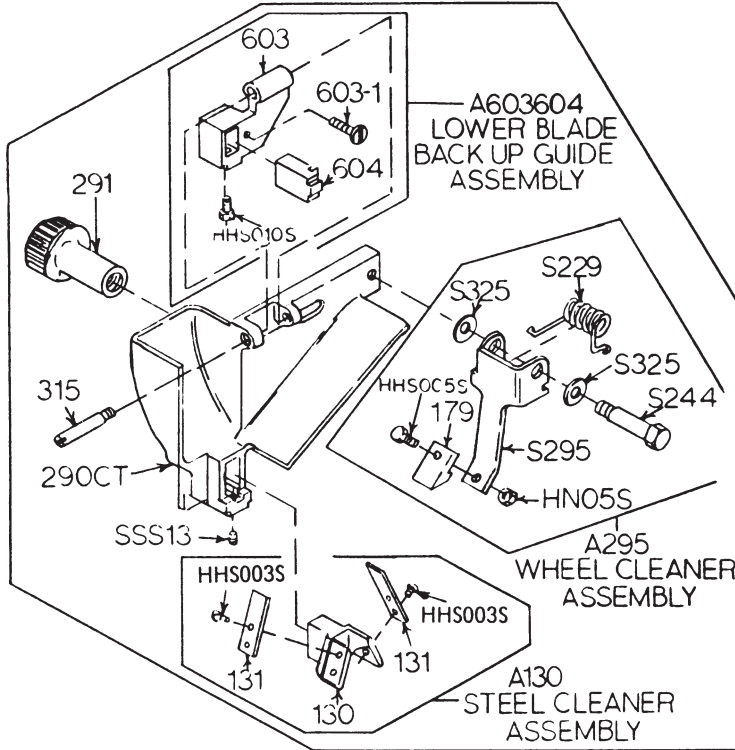

Item No.	Description
A130	Saw cleaner assembly
A290CT	Cleaning unit assembly
A295	Wheel cleaner assembly
A603604	Lower blade backup guide assembly
HHS005S	Hex head screw, 8-32 x 1/2 SS
HHS010S	Hex head screw, 10-32 x 3/8 SS
HHS003S	Hex head screw, 8-32 x 1/4 SS
HN05S	Hex nut, 8-32 SS
SSS13	Set screw, 1/4-20 x 3/8, cup point
S229	Wheel cleaner arm spring, SS
S244	Wheel cleaner arm stud, SS
S295	Wheel cleaner arm, SS
S325	Wheel cleaner arm stud washer, SS
130	Saw cleaner bracket
131	Saw cleaner, SS
179	Wheel cleaner
290CT	Lower cleaning unit casting
291	Cleaning unit fastener knob, 3/8 long
315	Lower guide bracket stud
603	lower guide bracket
603-1	Pan head screw to adjust guide
604	Lower blade backup guide

Item No.	Description
A116-18AL	Saw guide bar assembly for aluminum head
A116-18SS	Saw guide bar assembly for stainless head
A211MS-AL	Finger lift assembly for aluminum head
A211MS-SS	Finger lift assembly for stainless head
A602	Saw guide assembly upper
FW05S	Flat washer, 1/4 SS
HHS015S	Hex head screw, 10-32 x 3/4 SS
HHS020S	Hex head screw, 1/4-20 x 3/8 SS
HHS065S	Hex head screw, 5/16-18 x 1 1/2 SS
HN10S	Hex nut, 10-32 SS
LW05S	Lock washer, #10 SS
LW10S	Lock washer, 1/4 SS
RHS10S	Round head screw, 10-32 x 3/4 SS
RHS25S	Round head screw, 1/4-20 x 3/4 SS
S200B1	Stop stud guide bar
116-18	Saw guide bar, 18"
12662-AL	Saw guard for aluminum head
12662-SS	Saw guard for stainless head
17211-22	Finger lift shim, .022
17211-35	Finger lift shim, .035
193	Saw guide bar spring
211MS	Finger lift
211Q	Finger lift fastener knob, 4 point
601	Upper saw guide bracket
602AFSC	Upper saw guide, fish
602B	Upper saw guide
708	Decal, danger exposed blade

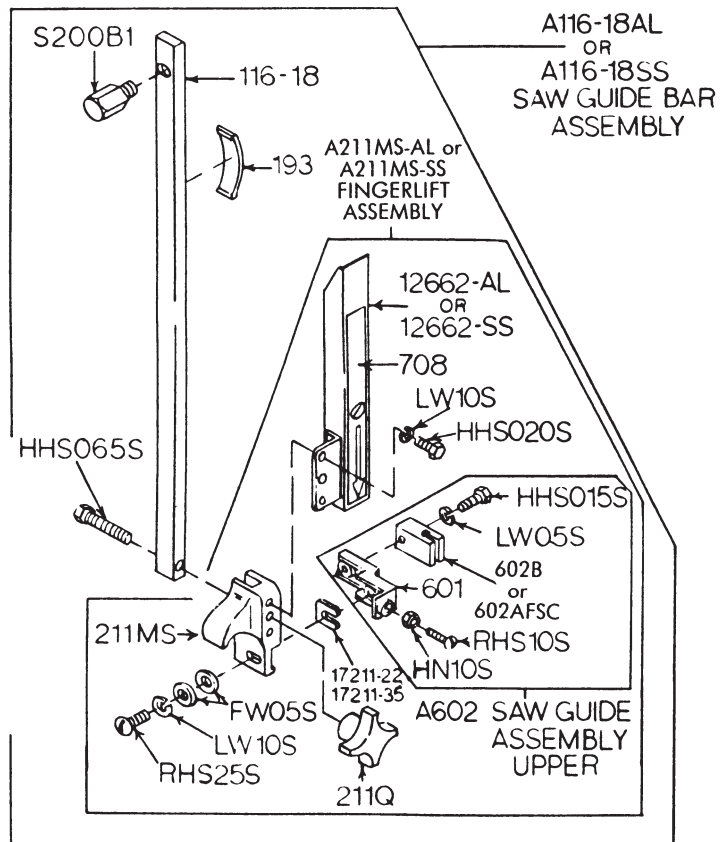

A415D OR AS415D
STATIONARY BAR ASSEMBLY

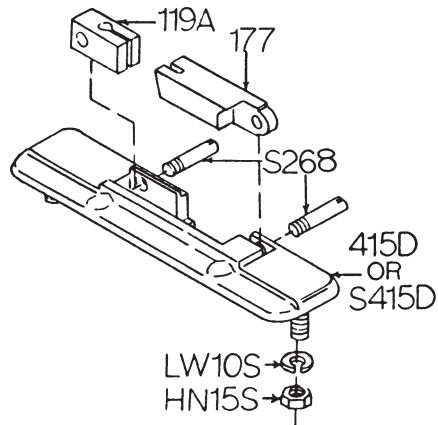

Item No.	Description
A415D	Stationary bar assembly
AS415D	Stationary bar assembly SS
HN15S	Hex nut, 1/4-20 SS
LW10S	Lock washer, 1/4 SS
S268	Stationary bar headless screw
S415D	Stationary bar SS
119A	Saw guide in stationary bar
177	Nylon filler
415D	Stationary bar

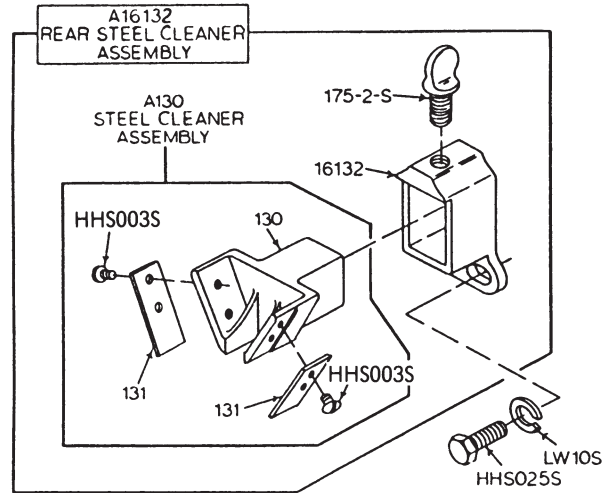

Item No.	Description
A130	Saw cleaner assembly
A16132	Steel cleaner assembly, rear
HHS025S	Hex head screw, 1/4-20 x 1/2 SS
HHS003S	Hex head screw, 8-32 x 1/4 SS
LW10S	Lock washer, 1/4 SS
130	Saw cleaner bracket rear
131	Saw cleaner SS
16132	Saw cleaner bracket holder, rear
175-2-S	Thumb screw, 1/4-20 x 1/2

A196
TENSION
SPRING
ASSEMBLY

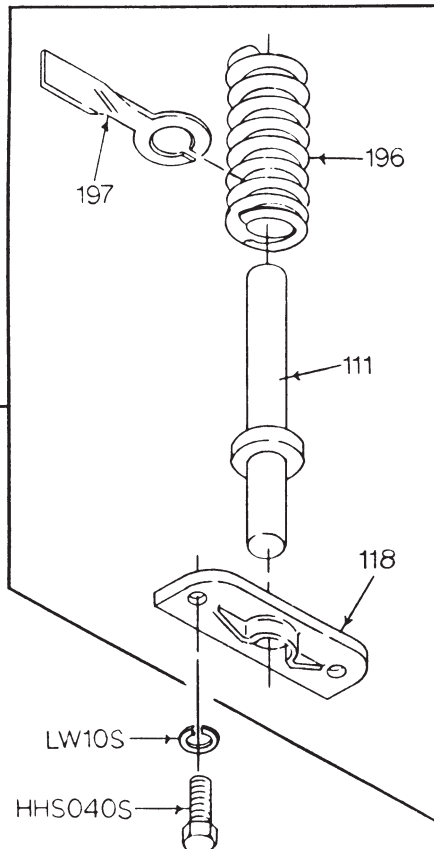

Item No.	Description
A196	Tension spring assembly
HHS040S	Hex head screw, 1/4-20 x 3/4 SS
LW10S	Lock washer, 1/4 SS
111	Tension spring pin
118	Tension spring plate
197	Tension spring gauge
196	Saw tension spring

A12155 MEAT CARRIAGE ASSEMBLY

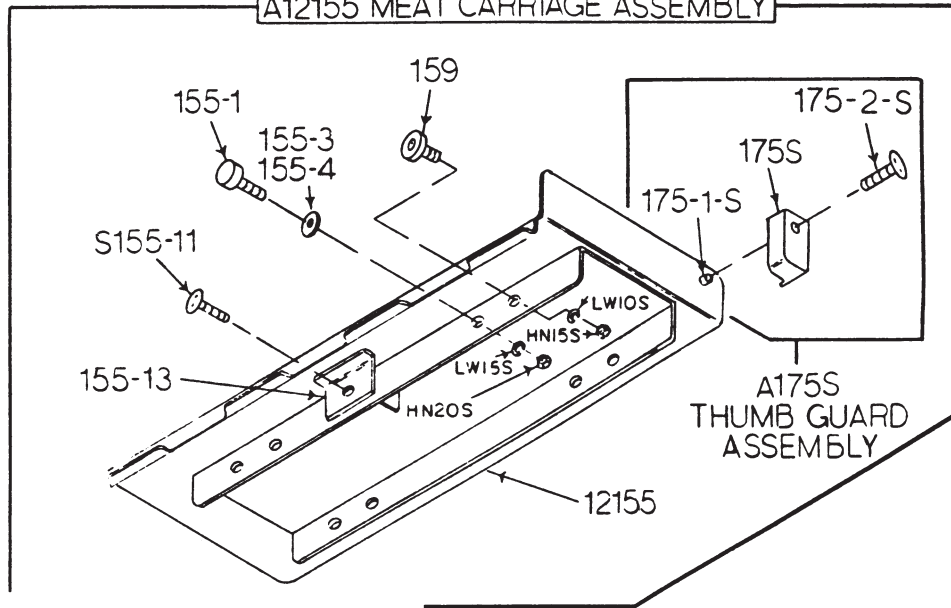

Item No.	Description	Item No.	Description
A12155	Meat carriage assembly	155-1	Meat carriage guide
A175S	Thumb guard assembly	155-3	Meat carriage guide spacer, .025
HN15S	Hex nut, 1/4-20 SS	155-4	Meat carriage guide spacer, .040
HN20S	Hex nut, 5/16-18 SS	155-13	Carriage stop angle, welded
LW10S	Lock washer, 1/4 SS	159	Meat carriage bearing
LW15S	Lock washer, 5/16 SS	175S	Thumb guard, nylon
S155-11	Meat carriage stop thumb screw	175-1-S	Thumb guard nut SS
12155	Meat carriage top & angle	175-2-S	Thumb screw, 1/4-20 x 1/2

A12120 CHANNEL ASSEMBLY 31"

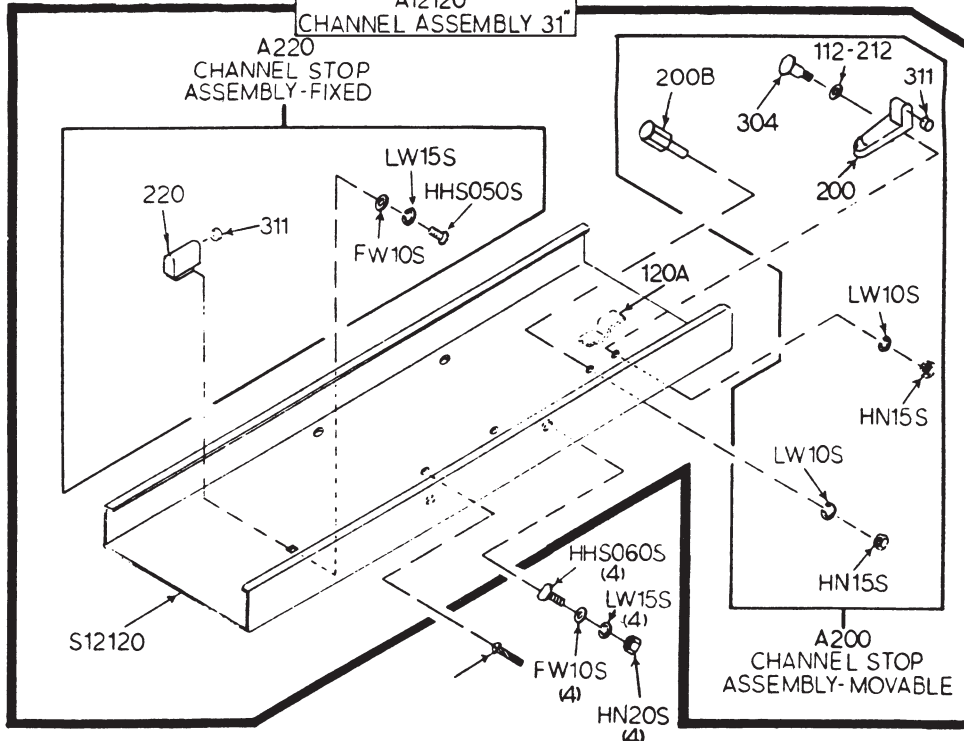

Item No.	Description	Item No.	Description
A12120	Channel assembly, 31.5"	LW15S	Lock washer, 5/16 SS
A200	Carriage stop assembly, movable	S12120	Channel, 31.5", SS
A220	Carriage stop assembly, fixed	112-212	Waved washer
FW10S	Flat washer, 5/16 SS	120A	Pusher plate clamp, welded
HHS050S	Hex head screw, 5/16-18 x 5/8, SS	200	Carriage stop, movable
HHS060S	Hex head screw, 5/16-18 x 1, SS	200B	Stop stud carriage stop
HN15S	Hex nut, 1/4-20 SS	220	Carriage stop, fixed
HN20S	Hex nut, 5/16-18 SS	304	Shoulder screw carriage stop
LW10S	Lock washer, 1/4 SS	311	Carriage stop rubber bumper

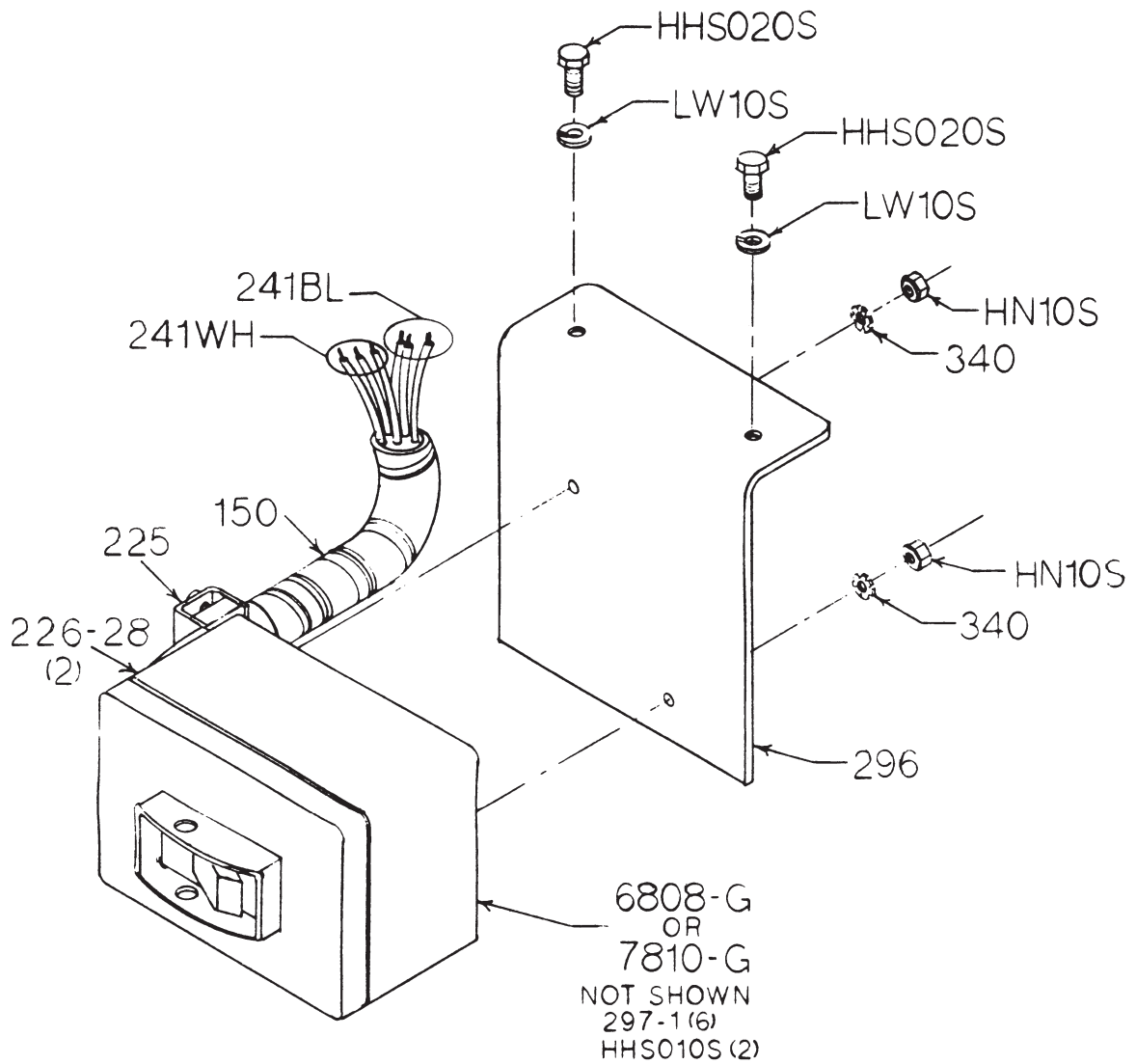

Item No.	Description
A6808-G-12	Toggle switch assembly, 1PH
A7810-G-12	Toggle switch assembly, 3PH
HHS010S	Hex head screw, 10-32 x 3/8 SS
HHS020S	Hex head screw, 1/4-20 x 3/8 SS
HN10S	Hex nut, 10-32 SS
LW10S	Lock washer, 1/4 SS
150	Conduit, 1/2"
225	Conduit connector, 90°
226-28	Washer, SS
241BL	Wire, black, 12GA, CSA & UL
241WH	Wire, white, 12GA, CSA & UL
296	Switch bracket SS
297-1	Wire terminal eyelet
340	Star lock washer
6808-G	Toggle switch, 1 phase
7810-G	Toggle switch, 3 phase

110 – 115 VOLTS

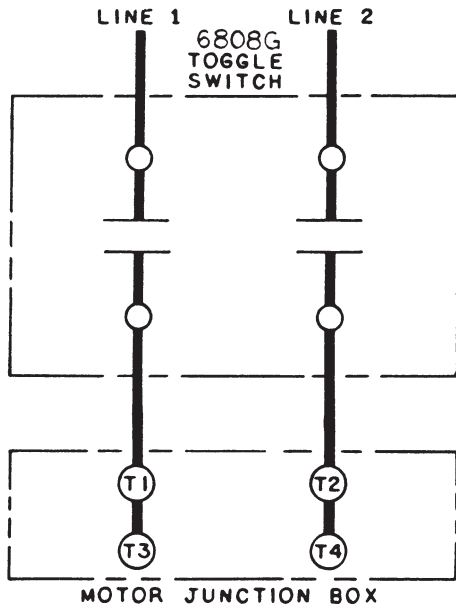

220 – 230 VOLTS

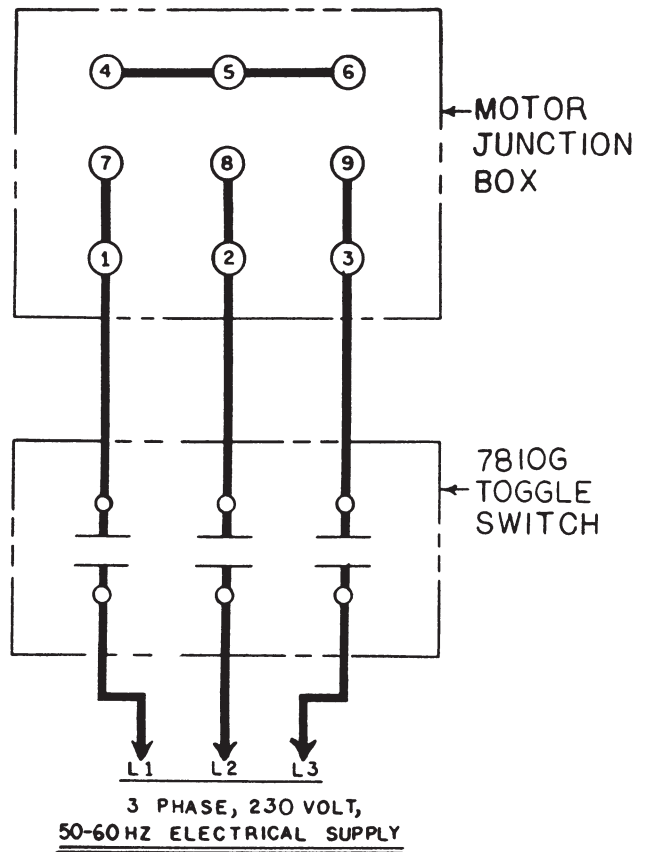
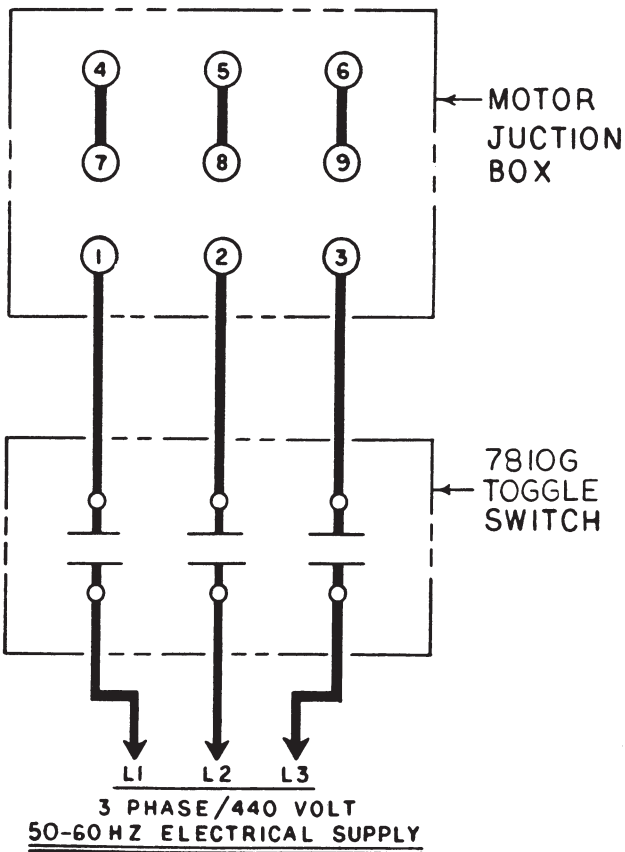
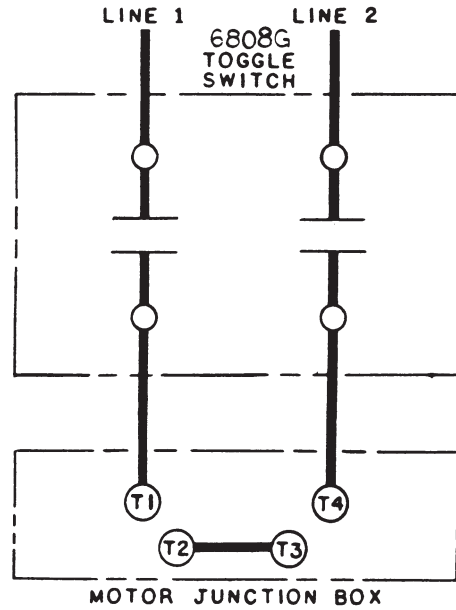

WATERTIGHT MAGNETIC SWITCH ASSEMBLIES (STROMBERG) INCLUDES MOUNTING BRACKET AND WIRES

Item No.	Description	Item No.	Description
A22612SG-502	BOK/PC-PB/E-18, 1HP, 104/115-50/60-1	A22612SG-516	BOK/PC-PB/B3, 1½HP, 440/460-3
A22612SG-504	BOK/PC-PB/E-15, 1HP, 104/115-50-1	A22612SG-518	BOK/PC-PB/C4.2, 1½HP, 380/415-50-3
A22612SG-506	BOK/PC-PB/A4.2, 1½HP, 208/220/230-50/60-3	A22612SG-520	BOK/PC-PB/E01-22, 1½HP, 104/115-50/60-1
A22612SG-508	BOK/PC-PB/B2.2, 1HP, 440/460-60-3	A22612SG-522	BOK/PC-PB/A01-12, 1½HP, 208/220/230-50/60-1
A22612SG-510	BOK/PC-PB/C3, 1HP, 380/415-50-3		
A22612SG-512	BOK/PC-PB/A6, 1HP, 220-50-3, 1½HP, 220/230-60-3		
A22612SG-514	BOK/PC-PB/A8, 1HP, 208/220/230-50/60-1, 1½HP, 220-50-3		

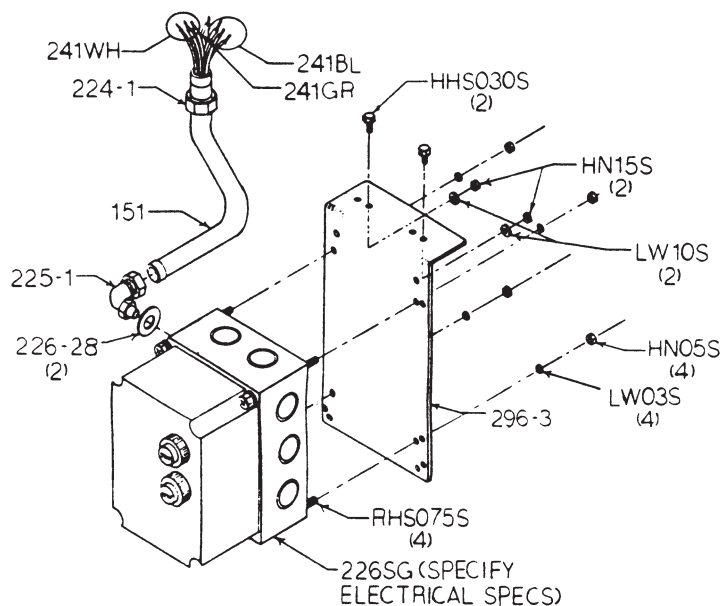

Item No.	Description	Item No.	Description
HHS025S	Hex head screw, ¼-20 × ½ SS	226SG-502	BOK/PC-PB/E18
HN05S	Hex nut, 8-32 SS	226SG-504	BOK/PC-PB/E15
LW03S	Lock washer, #8 SS	226SG-506	BOK/PC-PB/A4.2
LW10S	Lock washer, ¼ SS	226SG-508	BOK/PC-PB/B2.2
RHS075S	Round head screw, 8-32 × ¾ SS	226SG-510	BOK/PC-PB/C3
296-3	Switch bracket SS	226SG-512	BOK/PC-PB/A6
151	Watertight conduit	226SG-514	BOK/PC-PB/A8
225-1	Conduit connector, WT, 90°	226SG-516	BOK/PC-PB/B3
226SG-BOX	Switch box less cover	226SG-518	BOK/PC-PB/C4.2
226SG-CVR-B	Switch box cover with button holes	226SG-520	BOK/PC-PB/E01-22
226SG-ENCL-PB	Switch box complete with button holes	226SG-522	BOK/PC-PB/A01-12
226SG-GR	Green push button	226SG-524	BOK/PC-PB/E01-32
226SG-RD	Red push button	226SG-526	BOK/PC-PB/A01-15
226SG-OLK03	Overload relay, PATAM1K 3	226SG-528	BOK/PC-PB/B4.2
226SG-OLK04	Overload relay, PATAM1K 4.2	226SG-530	BOK/PC-PB/D3
226SG-OLK06	Overload relay, PATAM1K 6	226SG-531	BOK/PC-PB/A10
226SG-OLK08	Overload relay, PATAM1K 8	226SG-532	BOK/PC-PB/A12
226SG-OLK10	Overload relay, PATAM1K 10	226SG-534	BOK/PC-PB/B6
226SG-OLK12	Overload relay, PATAM1K 12	226SG-535	BOK/PC-PB/C6
226SG-OLK15	Overload relay, PATAM1K 15	226SG-538	BOK/PC-PB/D4.2
226SG-OLK18	Overload relay, PATAM1K 18	226SG-540	BOK/PC-PB/A15
226SG-OLK22	Overload relay, PATAM1K 22	226SG-541	BOK/PC-PB/A18
226SG-OLK32	Overload relay, PATAM1K 32	226SG-543	BOK/PC-PB/B8
226SG-S0AA	Contactor, Size 0, OK0W10L-208/220/230	226SG-548	BOK/PC-PB/D8
226SG-S0BB	Contactor, Size 0, OK0W10L-440/460	226-28	Washer, 1½ × 27/32 SS
226SG-S0CC	Contactor, Size 0, OK0W10L-380/415	241BL	Wire, black, 12 GA., CSA & UL
226SG-S0DD	Contactor, Size 0, OK0W10L-550/575	241GR	Wire, green, 12 GA., CSA & UL
226SG-S1AA	Contactor, Size 1, OK0W10L-208/220/230	241RD	Wire, red, 12 GA., CSA & UL
226SG-S1EE	Contactor, Size 1, OK0W10L-104/115	241WH	Wire, white, 12 GA., CSA & UL

**Model 22 Schematic Using 3PH Stromberg W.T. Switch
for 115 Volts, Single Phase, 60 Cycle Baldor Motor
to Eliminate Breaking Effect of Motor After Stop is Engaged**

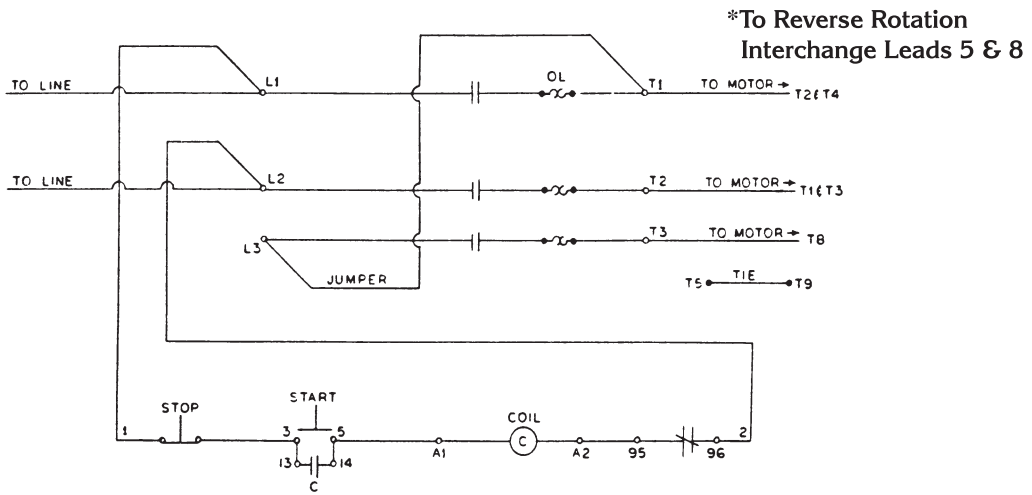

**Model 22 Schematic Using 3PH Stromberg W.T. Switch
for 230 Volts, Single Phase, 60 Cycle Baldor Motor
to Eliminate Breaking Effect of Motor After Stop is Engaged**

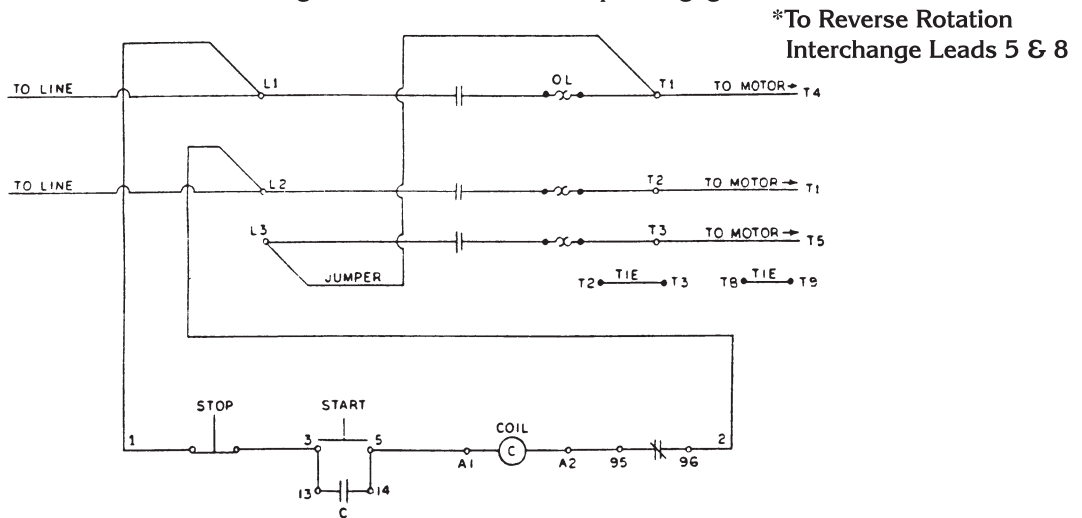

**Model 22 Schematic Using 3PH Stromberg W.T. Switch
for 220/440 Volts, Three Phase, 60 Cycle Baldor Motor**

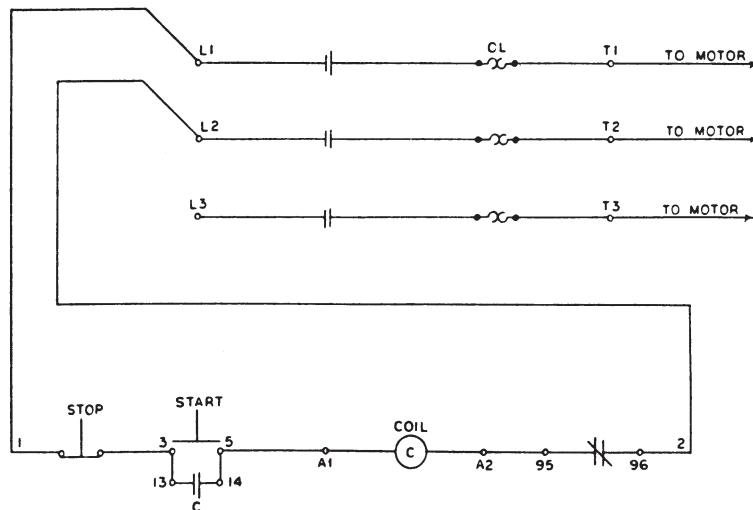

MODEL 22 PART NUMBERS AND DESCRIPTIONS

MODEL NO. AND SERIAL NO. REQUIRED WHEN ORDERING PARTS

Item No.	Description	Item No.	Description
M21-604994-D	Mtr, 1½HP, 115/230-60-1, open	12662-AL	Safety saw guard, w/708, AL head
M24-67242-D	Mtr 1½HP, 208/220/440-50/60-3	12678	Motor splash shield/bolted on
M27-605376-D	Mtr, 1½HP, 115/230-50-1, open	12700	Parts repair kit
M31-35J3561274B	Motor, 1½HP, 115/230-60-1, TE	130	Saw cleaner bracket, rear
M34-35G494X232B	Mtr, 1½HP, 220/440-50/60-3, TE	131	Saw cleaner, SS
FW05S	Flat washer, ¼ SS	14GP	Head door hinge pin, long, 1½"
HHS060S	Hex head screw, 5/16-18 x 1, SS	14GP-1	Head door hinge pin, short, 1¼"
S11	Ratchet trigger, SS	150	Conduit, flexible, metal, per inch
S19	Ratchet base, SS	151	Conduit, watertight, per inch
S12120	Channel, 31½", SS, #24613 on	155-1	Meat carriage guide
S12214	Side platter bracket, SS	155-3	Meat carriage guide spacer .025
S12217L	Base door left, SS, welded hinge	155-4	Meat carriage guide spacer .040
S12217L-1	Base door left, SS, bolted hinge	159	Meat carriage bearing
S12217R	Base door right, SS welded	16	Lower guide brg brkt to #6547
S12217R-1	Base door right, bolted hinge	16112	Head door latch
S12239	Base, stainless steel	16112-1	Hxhdbolt, SS 5/16-18 x 1 hddrlatch, use HHS060S
S12239SIP	Snap in plate, stainless	16132	Saw cleaner brkt holder rear
S12273	Meat gauge bracket, stainless	163A	Platter rod clip
S155-11	Meat carriage stop thumb screw, SS	163F	Platter spacer weld button use S163F
S155B-1	Meat carriage stop welded	17-3	Replace by A116-18 & 660
S163F	Platter spacer weld button, SS	17-3	Fngrlift wshr, 5/16 x .276 x .104, use FW05S
S189	Ratchet arm stud, stainless	17211-22	Finger lift shim .022
S200B1	Stop stud on saw guide bar	17211-35	Finger lift shim .035
S217C	Base door hinge pin, long, SS	175-1-S	Thumb guard nut, SS
S217E	Base door hinge pin, short, SS	175-2-S	Thumb screw ¼D x ½
S229	Wheel cleaner arm torsion spring, SS	175S	Thumb guard, nylon
S235	Taper pin, SS, 4 x ¾	177	Stationary bar nylon filler
S239-B30	Base foot welded, stainless	179	Wheel cleaner
S244	Wheel cleaner arm stud, SS	19	Ratchet base, replaced by S19
S253	Upper wheel aligning screw, SS	19CB	Ratchet base carriage bolt ¼-20 x ¾
S262	Meat gauge release handle, SS	193	Saw guide bar spring
S268	Stationary bar hdless screw SS	196	Saw tension spring
S295	Wheel cleaner arm, SS	197	Tension spring gauge
S325	Wheel cleaner arm washer, SS	200	Carriage stop, movable
S360CB-1	Carriage bolt 3/8-16 x 1¼, SS	200B	Stop stud carriage stop
S415D	Stationary bar, stainless	211MS	Finger lift bracket
S416	Platter locator weld pin, SS	211P	Finger lift fastener knob, 5/16 short
S660	Saw guard on head door, SS, use 660	211Q	Finger lift fastener knob, 4 point
S7-0	Channel bracket, SS	212CP	Platter rod cotter pin
10-0	Ratchet arm	212W-E	Platter rod, England
11	Ratchet trigger, replaced by S11	220	Carriage stop, fixed
111	Tension spring pin	221-52	V-belt, 52"
112-212	Waved washer, 2¼ ID, 5/8 OD	221-53	V-belt, 53"
116-18	Saw guide bar, 18"	223	Scrap bucket bumper
118	Tension spring plate	224	Conduit connector, straight
119A	Saw guide in stationary bar	224-1	Conduit connector, WT, straight
119FSC	Saw guide in stationary bar, fish	225	Conduit connector, 90°
12003PC	Lower wheel, 12", powder coated	226-28	Conduit connector washer
12003QPC	Upper wheel, 12", powder coated	228	Replaced by A116-18 & 660
12005A	Head, new style	230DL	Upper shaft seal, double lip
12006	Head door, old style	231DL	Lower shaft seal, double lip
12006A	Head door, new style	234	Grease fitting, upper wheel
12120	Channel 31 inch #24613 on	237	Up shaft castellated locknut
12120A	Channel 22 w/gde bar to #24612	238	Up shaft castld locknut washer
12154	Table extension, SS	239-B30-1	Base foot, carbon, replaced by S239-B30
12155	Meat carriage top, angle & stop #24613 on	239-B31-2	Pipe leg, aluminum, 6"
12155-OS	Meat carriage, 6 brg., thru #24612	239-B32-AR	Pipe leg cap
12163B	Platter neck guard	239-B34	Basefoot insert w/slve, SS
12163B-1	Platter neck guard, England, Al. head	240	Ratchet trigger spring
12212W	Platter rod	242L	Base door lock, left
12232	Scrap bucket	242R	Base door lock, right
12251AL	Upper v-belt pulley 9 x 1, aluminum	247	Upper shaft
12272	Meat gauge gear rack	248	Upper wheel hub cap
12275	Meat gauge plate, 13½"	249	Base door handle
12301	Serial number plate (ser. no. required)	252X	Upper shaft lock nut
12302	Saw blade, 91"	255MS	Safety saw guard w/#708 decal, repl. by 12662-AL
12308	Babbitt pocket shield	256P	Safety pusher plate, composition
12313-022	Operating and service manual, #35301 on	256PM	Safety pusher plate, aluminum
12335X	Upper wheel hinge plate	259	Conduit anti-short bushing
12522	Hinge pair, RH-long pin/BaseDr	260	Aluminum slide gib
12523	Hinge pair, RH-short pin/BaseDr	260ALS	Shim for slide gib
12524	Hinge pair, LH-long pin/BaseDr		
12525	Hinge pair, LH-short pin/BaseDr		

Item No.	Description	Item No.	Description
261	Lwr bearing housing to #12633	312	Up wheel cleaning arm bracket use 12335X
264-1	Meat gauge release hand wheel	315	Lower guide bracket stud
264G	Meat gauge hand wheel groove pin	324A	Motor shim 1/8"
265	Meat gauge release spring	331	Platter bracket rubber bumper
267	Meat gauge release cotter key	334-6-S	Nylon saw rider, obsolete
270	Meat gauge release pin	340	Star lock washer
271	Meat gauge worm gear	360	Lower bearing housing
272-6-S	Meat gauge bracket wing nut	360A1	Bearing housing angled grease fitting
275BRG	Meat gauge busing, long	360B	Brg hsgn tilt set screw
275BRG-1	Meat gauge bushing, short	361	Lower shaft
277	Lower shaft key, v-belt side	361A	Washer convert 361 to 57 (2 req'd.)
280	Motor shaft key	362	Lower bearing housing cap
283	Idler pulley bracket	374	M-6 Lubriko grease, 14 oz.
284	Idler pulley	375	Drive screw, for name plate
285	Idler pulley bearing	376	Drive screw, SS, #10 x 1/2
285W-1	Idler pulley spacer	4-15	Motor pulley 4 1/2 x 3/4
285W-2	Idler pulley spacer	4-30AL	Motor pulley, AL, 60cy, 5 x 3/4
286	Idler pulley shaft	415D	Stationary bar
288	Idler pulley grease cap	416	Platter locator weld pins, use S416
289	Idler pulley retainer	513	Upper wheel hub gasket
290CT	Cleaning unit casting	530	Retaining snap ring
291	Cleaning unit fastener knob 3/8 long	601	Upper saw guide bracket
296	Toggle switch bracket	602B	Saw guide, upper
296-11	External mnt sw brkt/for WTmag	602AFSC	Saw guide, upper bracket, fish
296-3	Sw brkt, ACW, BCW, AAA1, TAA1	603	Lower guide bracket
296-5A	Special switch bracket, England	603-1	Pan head screw adjust guide
296A	Switch bracket, England & Norway	604	Saw guide lower blade back-up
300	Lower shaft Woodruff key	660	Saw guard on head door
303	Lower shaft nut	6808-G	Toggle switch, 1 phase
304	Carriage stop shoulder screw	71-1	Upper wheel hinge bracket
310	Waved washer	7810-G	Toggle switch, 3 phase
311	Rubber bumper for carriage stops		

COMPLETE ASSEMBLIES FOR MODEL 22

Item No.	Description	Item No.	Description
AS12217L	Base door assembly, left wid/hng, SS	A19	Ratchet assembly
A116-18	Saw guide bar assembly	A200	Carriage stop assembly, movable
A12003U	Up whl asem w/o hinge plate	A211MS-AL	Finger lift assembly, AL head
A12003UPC	Upper wheel assembly w/o hinge plate, powder coated	A220	Channel stop assembly, fixed
A12003U335	Upper wheel assembly w/hinge plate	A227	Upper bearing cup/cone assembly
A12006	Head door assembly thru #31638	A247	Upper shaft brg asem w/o wheel
A12006A	Head door assembly #31639 on	A249L	Base door handle assembly left
A12120	Channel assembly 31", #24613 on	A249R	Base door handle assembly right
A12155	Meat carriage assembly, #24613 on	A262	Meat gauge release assembly
A12155-OS	Meat carriage asem. to #24612	A290CT	Cleaning unit assembly, w/604
A12163-1	Stationary platter assembly #15617 on	A295	Wheel cleaner assembly
A12275	Meat gauge plate assembly	A360	Lower bearing housing assembly
A130	Saw cleaner assembly	A363	Lower bearing cup/cone assembly
A155-1K	Guide bar conversion kit	A415D	Stationary bar assembly
A16014L	Head door hinge assembly, lower, short pin	A602	Saw guide assembly, upper
A16014U	Head door hinge assembly, upper, long pin	A603604	Lower blade bk-up guide asem
A16112	Head door latch assembly	A6808-G-12	Toggle sw. asem, 1 ph, w/harness
		A7810-G-12	Toggle sw. asem, 3 ph, w/harness

— NOTES —

CLEANING THE BIRO POWER CUTTER:

Disconnect electrical power to the machine before cleaning. Parts to be removed have been made accessible and can be removed without tools. Notice in the drawing below that all parts are numbered. Each part should be removed for cleaning in the numbered sequence shown. To insure cleaner cuts, keep the cleaning system in good condition. Parts on the cleaning system that should be checked weekly, and changed as required are as follows: wheel cleaners, upper and lower, Item No. 179; steel saw cleaners, Item No. 131; steel guide in stationary bar, Item No. 119A; upper saw guide, Item No. 602B; lower blade back up guides, Item No. 604; nylon filler, and Item No. 177.

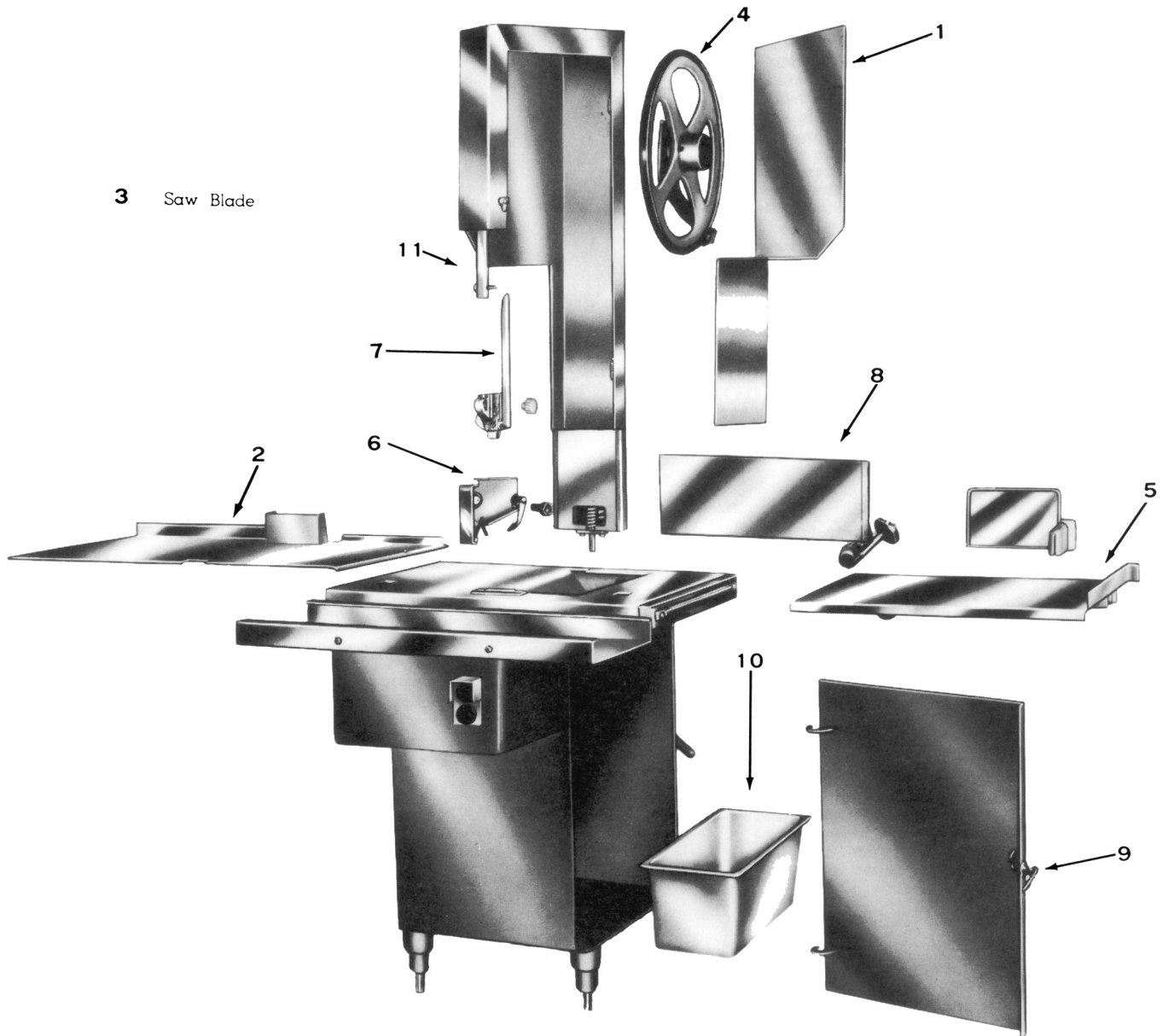

To clean power cutter remove parts as show, in sequence, 1,2,3,4, etc.

(NOTE: This page is not for ordering parts)

— NOTES —

— LIMITED WARRANTY —

WARRANTY: The BIRO Manufacturing Company warrants that Model 22 will be free from defects in material and workmanship under normal use and with recommended service. BIRO will replace defective parts, which are covered by this limited warranty, provided that the defective parts are authorized for return, shipping charges prepaid, to a designated factory for inspection and/or testing.

DURATION OF WARRANTY: The warranty period for all parts covered by this limited warranty is one (1) year from inspection/demonstration advised on the returned Warranty registration card, or eighteen (18) months from original factory shipping date, whichever occurs first, except as noted below.

PARTS NOT COVERED BY WARRANTY: The following are **not** covered by this limited warranty: wearable parts on the cleaning system such as Wheel Cleaners, Item No. 179; Saw Cleaners, Item No. 131; Saw Guide in Stationary Bar, Item No. 119A; Upper Saw Guide, Item No. 602B; Lower Blade Back Guide, Item No. 604; Nylon Filler, Item No. 177. This limited warranty does not apply to machines sold as used, rebuilt, modified, or altered from the original construction in which the machine was shipped from the factory. (Water contaminated electrical systems are not covered under this limited warranty.) BIRO is not responsible for electrical connection of equipment, adjustments to switch controls or any other electrical requirements, which must be performed only by a certified electrician. BIRO is not responsible for service charges or labor required to replace any part covered by this limited warranty or for any damages resulting from misuse, abuse, lack of proper or recommended service.

EXCLUSION OF WARRANTIES AND LIMITATION OF REMEDIES: BIRO gives no warranties other than those expressly stated in this limited warranty. THE IMPLIED WARRANTY OF MERCHANTABILITY, THE IMPLIED WARRANTY OF FITNESS FOR PROCESSING OF FOOD PRODUCTS, AND ALL OTHER IMPLIED WARRANTIES ARE SPECIFICALLY EXCLUDED. BIRO IS NOT LIABLE FOR CONSEQUENTIAL OR INCIDENTAL DAMAGES, EXPENSES, OR LOSSES. THE REMEDIES PROVIDED IN THIS BIRO LIMITED WARRANTY ARE PURCHASER'S SOLE AND EXCLUSIVE REMEDIES AGAINST BIRO.

REGISTRATION CARDS: You must sign, date and complete the warranty card supplied with each machine. The warranty card must be returned to The Biro Manufacturing Company for proper registration. If no warranty card is returned to BIRO, the warranty period will begin from the date the machine was originally shipped from the factory.

HOW TO GET SERVICE:

1. Contact the agency from whom you purchased the machine.
2. Consult the yellow pages of the phone directory for the nearest authorized dealer.
3. Or call BIRO Service Department (419) 798-4451 who will put you in contact with the nearest service agency.

THE BIRO MANUFACTURING COMPANY

1114 Main Street
Marblehead, Ohio 43440-2099
Ph. 419-798-4451
Fax 419-798-9106
E-mail: Service@birosaw.com
Web: <http://www.birosaw.com>