



MODEL 109PCM
HORIZONTAL SLICER
OPERATING and SERVICE MANUAL
PARTS LIST & GENERAL INSTRUCTIONS



☆ **IMPORTANT NOTICE** ☆

This Manual contains important safety instructions which must be strictly followed when using this equipment.

Mod. 109PCM
352-12-16-3 B

TABLE OF CONTENTS:

	PAGE
NOTICE TO OWNERS AND OPERATORS	1
SAFETY TIPS	2
INSTALLATION	3
OPERATION	4
THICKNESS ADJUSTMENT	4
MACHINE OPERATION	5
OPERATION SEQUENCE	6
INTERLOCK SYSTEM	6
SLICER BLADE REMOVAL	7
LUBRICATION	8 & 9
WIRING DIAGRAM: 200/208/230/460V-60HZ-3PH.	10 & 11
PARTS DIAGRAMS	12 - 19
CONVEYOR OPTION DIAGRAMS	20 - 23
CONVEYOR WIRING DIAGRAM	24
RECOMMENDED SPARE PARTS LIST	25
OPERATOR'S NOTES	26
OPERATOR'S SIGNATURE PAGE	27
LIMITED WARRANTY	28

NOTICE TO OWNERS AND OPERATORS

BIRO'S products are designed to process food products safely and efficiently. Unless the operator is properly trained and supervised, however, there is the possibility of a serious injury. It is the responsibility of the owner to assure that this machine is used properly and safely, strictly following the instructions contained in this Manual and any requirements of local law. Be sure a BIRO Authorized Representative has reviewed the installation before this machine is initially started up and put into service. Contact BIRO Manufacturing Co. to locate your local Biro Representative.

No one should use or service this machine without proper training and supervision. All operators should be thoroughly familiar with the procedures contained in this Manual. Even so BIRO cannot anticipate every circumstance or environment in which its products will be used. You, the owner and operator, must remain alert to the hazards posed by the function of this equipment - particularly the SHARP KNIFE BLADE. No one under eighteen (18) years of age should operate this equipment. If you are uncertain about a particular task, ask your supervisor.

This Manual contains a number of safe practices in the SAFETY TIP section. Additional warnings are placed throughout the Manual. Warnings related to your personal safety are indicated by:



OR



Warnings related to possible damage are indicated by:



If any warning label or Manual becomes misplaced, damaged, or illegible, please contact your nearest Distributor or BIRO directly for a replacement.

Remember, however, this Manual or the warning labels do not replace the need to be alert and to use your common sense when using this equipment.

This Manual applies to all Model 109PCM Horizontal Slicers.

- NOTE -

**A copy of this manual is included with each
MODEL 109PCM HORIZONTAL SLICER**

**The descriptions and illustrations contained in this manual are not binding.
The manufacturer reserves the right to introduce any modification without
updating the manual.**

SAFETY TIPS



SHARP KNIFE BLADE TO AVOID SERIOUS PERSONAL INJURY

***NEVER** Operate This Machine Without Proper Training and Authorization By Your Supervisor or If Under 18 Years.*

***ALWAYS** Read Operating and Service Manual Thoroughly **BEFORE** Operating, Servicing or Cleaning.*

***ONLY** Install on a Level, Non-Skid Surface in a Clean, Well-Lighted Area Away From Children and Visitors.*

***ONLY** Use a Qualified Electrician to Install According to Local Building Codes: Machines **MUST** Be Properly Grounded.*

***NEVER** Place Hands or any Body Part in Cutting Area.*

***DO NOT** Open Chamber Covers while Machine is Operating.*

***NEVER** Disconnect or Bypass Safety Interlock Switches.*

***ALWAYS** Turn Off, Unplug From Power Source and Perform Lockout/Tagout Procedure to This Machine **BEFORE** Cleaning, or Servicing.*

***NEVER** Leave Machine Unattended While the Slicer is Running.*

***DO NOT** Alter or Modify This Machine in any Way From its Original Form. This Machine in its Original Form Meets the Intent of O.S.H.A. Applicable Standards.*

***DO NOT** Operate Machine With Missing Parts.*

***ALWAYS** Comply with all Regulations for Food Handling, Packaging, and Storing.*

***PROMPTLY REPLACE** Any Worn or Illegible Warning and Instruction Labels.*

***ONLY USE BIRO** Parts and Accessories Properly Installed.*

INSTALLATION

1. Read this Manual thoroughly before installation and operation. **Do not** proceed with installation and operation if you have any questions or do not understand anything in this Manual. Contact your local Distributor, or BIRO **irst**.
2. Install machine on a level, solid, non-skid surface in a well-lighted work area away from children and visitors.
3. Lock the Casters in the fixed position before operating machine.
4. Electrical supply must be connected correctly, and properly grounded. The voltage must match the unit voltage as labeled. See Electrical Specifications, or contact Biro with the serial number of the machine.
5. Check the Draw Lever by opening the Clutch Door on the right hand side of the unit. Make sure the $\frac{9}{16}$ hex head fastener is tight on the eccentric hub and the linkage arm adjustment handle is tight.
6. For operation, turn Main Switch (Red Handle) "ON." Close the blade door, clutch door and covers. Twist & Pull the emergency stop into the "out" position. Open one cover and close again to "initiate" the electronics. The Slicer is now operational.
7. The blade must have a sharp smooth edge. The blade is 5mm (.197) thick and replacement blades must also be 5mm thick. Rotate the blade manually to ensure proper clearance. This procedure must be performed on initial installation and with all blade replacements. Every time a blade is replaced, turn it at least one revolution by hand, by Pressing and Holding the "BRAKE RELEASE" button with your left hand. Open the Blade Door with your right hand and rotate the back, flat edge of the blade clockwise. The blade may also be turned by hand to the most convenient position for disassembly, assembly, removal of product scraps, cleaning, etc...
8. Check Blade Rotation; the blade must travel downward through the product. When facing the blade it must rotate clockwise. single rotation may be achieved by selecting "JOG" and pressing the "Green Start" button. The direction of rotation may be changed by interchanging any two phase leads within the plug. CAUTION! Do not interchange the ground lead. Note: Blade rotation should be changed only by a recognized Biro representative or a certified electrician.
9. To move the Product Pusher Assembly, squeeze the hand lever which disconnects the Product Pusher from the feed screw. The Product Pusher can then be freely moved by hand left or right. When the hand lever is released, the Feed Screw will engage, and the Product Pusher will advance automatically. Allow 2 or 3 blade revolutions for Product Pusher to positively engage.
10. Product to be cut must be placed with its straight side against the loading chamber wall, toward the front edge, nearest the operator. Engage the product securely to the Product Pusher Gripper.
11. If Product does not fill the Loading Chamber width by 70%, use the Side Product Deflector, item number **PC103**. If the Product width is over 70% remove the Side Deflector by depressing the release button, and sliding the deflector to the right.

OPERATION

Product should be placed in the Loading Chamber with its straight side against the loading chamber wall, toward the front edge, nearest the operator. Engage the product securely to the Product Pusher Gripper. Product must advance toward the blade.

Turn the Main Disconnect Switch (Red Handle) “ON.”

Turn Selector switch to “RUN.”

To adjust cutting thickness: Open the Clutch Door on the right hand side of the unit.

The Thickness can be varied from $\frac{1}{16}$ ” (1.6mm) to $1\frac{1}{8}$ ” (28.6mm).

There are two **Thickness Scales** on the Linkage arm attached to the indexing clutch.

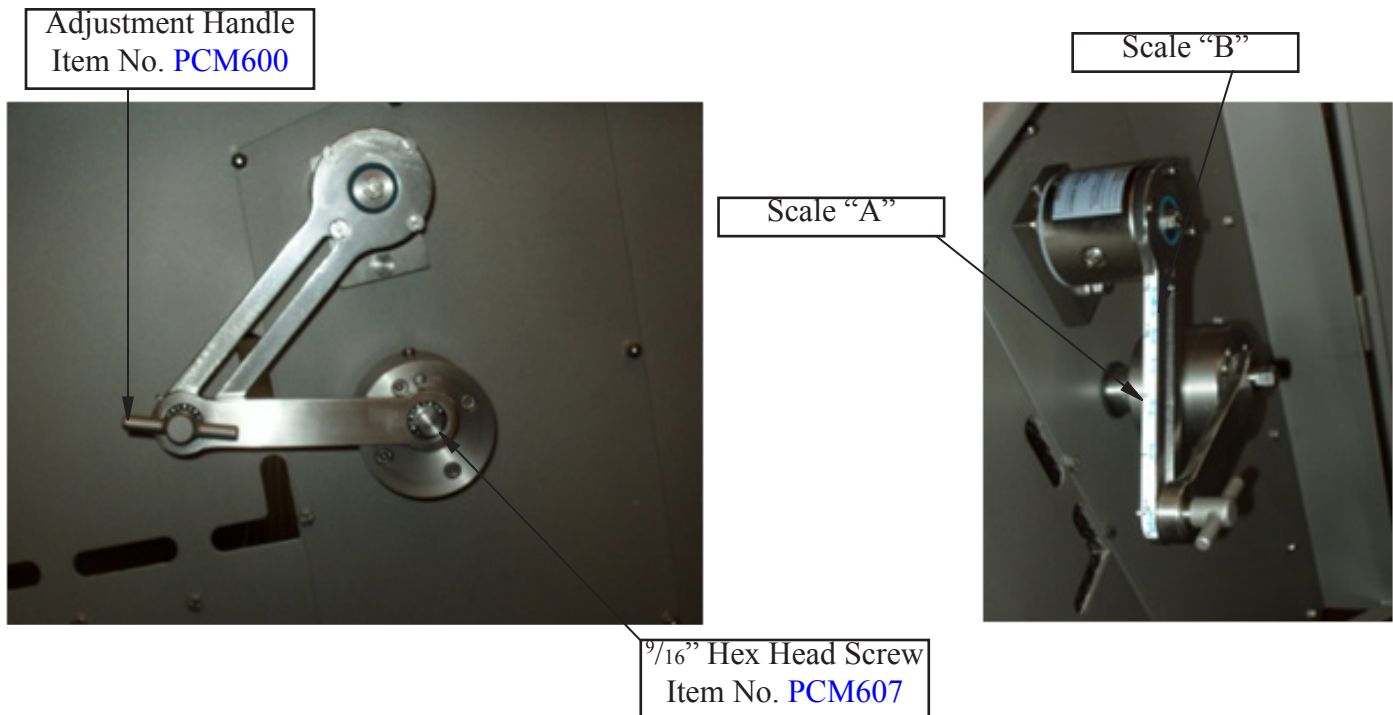

Scale "A"- the inside thickness scale range is $\frac{1}{16}$ ” (1.6mm) to $\frac{1}{4}$ ” (6.4mm).

Scale "B"-the outside thickness scale range is $\frac{5}{16}$ ” (7.9mm) to $1\frac{1}{8}$ ” (28.6mm).

To adjust the Thickness Range on scale “A”; Loosen the $\frac{9}{16}$ ” hex head screw, item number [PCM607](#), attaching the Draw-Lever to the eccentric hub with a box-end wrench. Place the $\frac{9}{16}$ ” hex head screw into the threaded hole marked “A” on the Eccentric Hub and Tighten.

The Slicer is ready for final Thickness Adjustment.

EXAMPLE A: To obtain a $\frac{1}{4}$ ” (6.4mm) Thickness on the “A” scale, loosen the Linkage Arm Adjustment Handle, item number [PCM600](#), slide the handle with the indicator to the $\frac{1}{4}$ ” mark on scale “A” and tighten the Adjustment Handle.

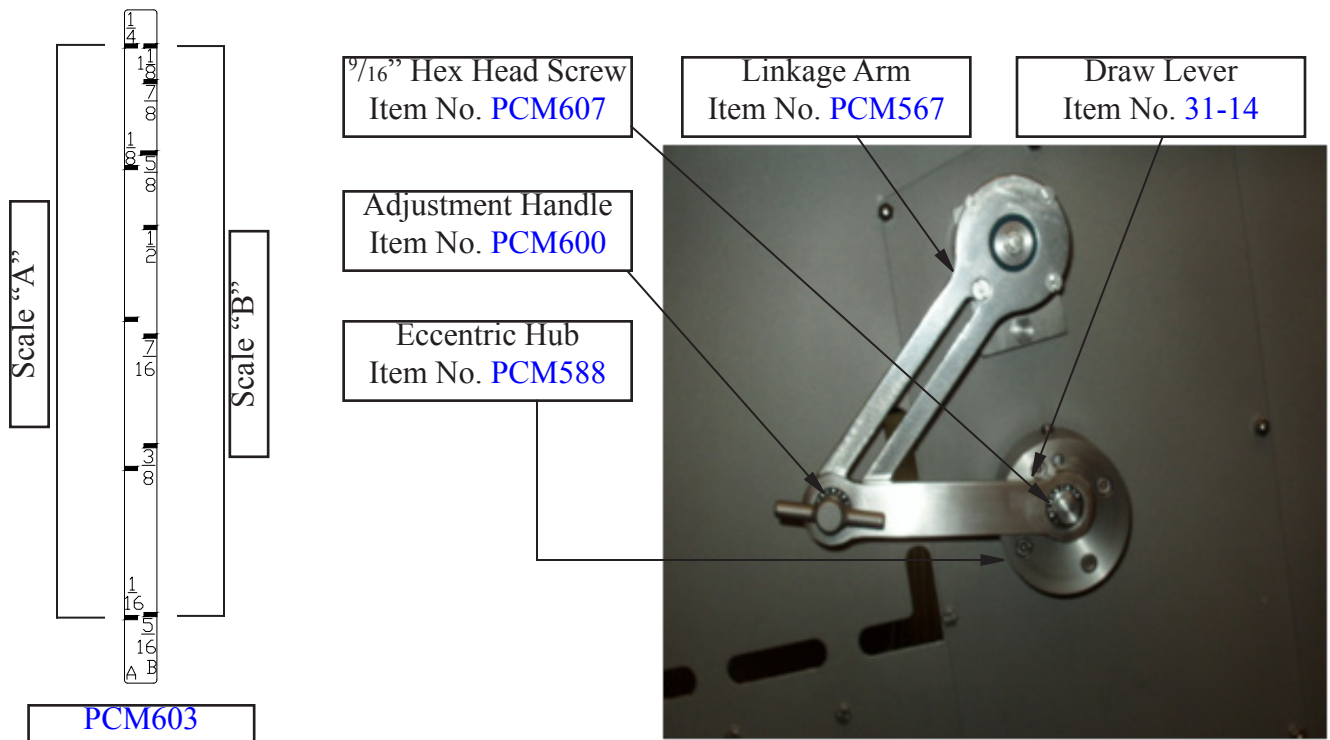

EXAMPLE B: To obtain a $\frac{7}{8}$ " (22.2mm) Thickness on the "B" scale, loosen the $\frac{9}{16}$ " hex head screw, item number [PCM607](#) located on the eccentric hub, item number [PCM588](#). Move the $\frac{9}{16}$ " hex head screw to the threaded hole marked "B" on the Eccentric Hub and retighten. Loosen the Linkage Arm Adjustment Handle, item number [PCM600](#), slide the handle with the indicator to the $\frac{7}{8}$ " (22.2mm) mark on Scale "B" and retighten the adjustment handle. The Slicer is now ready to cut product at $\frac{7}{8}$ " (22.2mm) thick.

MACHINE OPERATION

Press the **Green Start Button**.

Product will advance toward the blade automatically in thickness increments as adjusted above. When the Product Pusher Assembly has completely advanced to the left, the slicer will shut off.

Open the Loading Chamber Cover. Squeeze the hand-lever and move the Product Pusher Assembly to the right to the desired location for reloading the next product to be processed.

Open the Receiving Chamber Cover and remove the cut product.

Close the Receiving Chamber Cover.

Clean the Product Gripper of any product end surplus.

Load more product, and repeat the previous steps.

"JOG" Mode- This selection is used for a single-rotation (stroke) of the blade. It is used for a specific cut-off length without using the Product Pusher.

BRIEF OPERATING SEQUENCE

Turn the Main Disconnect Switch (Red Handle) “ON.”

Close Blade Door, Clutch Door, and Chamber Covers.

Twist and Pull out the Emergency Stop Switch.

Open the Loading Chamber Cover Slightly, and close again. The Slicer is now operational.

Load the product to be cut and engage the product to the Product Pusher Gripper. Close the Loading Chamber Cover. Turn the Selector Switch to “**RUN**”. Press the **Green Start Button**.

After cutting is complete, open the Loading Chamber Cover, and while squeezing the hand lever of the Product Pusher Assembly move it to the right to the desired location.

Open the Receiving Chamber Cover and remove the cut product.

Close the Receiving Chamber Cover.

Clean the Product Gripper of any surplus.

Repeat the previous steps.

INTERLOCK SYSTEM

The Horizontal Slicer can only **Start** after the Blade Door, Clutch Door and Chamber Covers are **closed**, and the Emergency Stop is in the “**out**” position. Open one Cover briefly, and close again to initiate the electronics.

The Horizontal Slicer will not operate with any of the doors and/or Chamber Covers in the open position.

SLICER BLADE REMOVAL

Turn main disconnect switch (Red Handle) "ON." Open the Blade Door.

Press and hold in the Brake Release button with your left hand. The blade may now be moved by hand into the most suitable position for disassembly. Rotate the back flat edge of the blade with your right hand to desired position. **Release** the Brake Release button.

Turn the main disconnect switch (Red Handle) "OFF," and **Unplug** the Horizontal Slicer from the Power Source before removing the Blade.

Use a $\frac{9}{16}$ " Box Wrench to loosen only the outer 4 fasteners.

Do not loosen the center fastener.

Grip the back flat edge of the blade firmly with one hand and use the other hand to loosen and remove the 4 fasteners.

Secure the removed Blade in a stable position and safe location.



LUBRICATION

The Slicer Product Pusher Feed Screw will need to be lubricated periodically using the Haynes Spray U.S.P. Light Duty Sanitary Lubricating Spray. The Spray is Light, Tasteless, and colorless, odorless oil. NSF (National Sanitation Foundation) rated H1. U.S.D.A. rated H-1. All ingredients are FDA approved.

It is necessary to lubricate the Feed Screw with the Spray weekly or when excessive drag is felt.

1. Always turn “OFF” the Slicer, Disconnect the Power Cord (Unplug Power Cord from the Electrical Outlet).
2. Open the Load Chamber Cover. Between the top Cover and the Loading Chamber wall locate the Feed Screw between the Slot
3. Spray the Feed Screw Lightly, the entire length.
4. Pull the Product Pusher Handle Release together and move the Product Pusher back and forth several times.
5. Wipe off excess oil.



THE WORLD'S LEADING MANUFACTURER OF PREMIUM FOOD GRADE LUBRICANTS

HAYNES SPRAY

U.S.P.* Light Duty Sanitary Oil
9 oz Aerosol Spray Cans
NSF rated H-1

*United States Pharmecuetical Standards



Haynes Spray is a light duty sanitary oil lubricant for all sanitary machine parts. This lubricant is authorized by the NSF (rated H1) for use in food processing plants for incidental food contact. All ingredients are FDA approved.

Haynes Spray, The U.S.P.* Light Duty Sanitary Spray can be used as an oil lubricant for food processing equipment. This sanitary oil can be used safely on drawer slides, doors, hinges, wheels, carts, or anywhere a light duty oil is needed in and around the food processing area. Haynes Spray contains no animal or vegetable fats and is absolutely neutral. It will not turn rancid, contaminate or taint food products. It is odorless, tasteless, colorless and non-toxic.

COMMON APPLICATIONS

- SANITARY VALVE STEMS
- HOMOGENIZER PISTONS & RINGS
- POSITIVE PUMP PARTS
- WHEELS (carts, chairs, equipment)
- HINGES (doors, windows, equipment)
- SLIDES
- INTERNAL MACHINERY PARTS
- ANTI-RUST FILM
- FILLING MACHINES
- GATES

TECHNICAL DATA INFORMATION

TEST	ASTM Method	Typical Test Results
Consistency (Spec Grav @ 25C/25C)	D4052	0.87
Viscosity (Saybolt @100°F)	D445	355
Viscosity (Kin @40°C)	D445	68
Flash Point (COP Flash)	D92	430°F
Pour Point	D97	-5°F to -10°F
Color, Taste, & Odor	LATM092/145	None
Operating Range, Min °F, Max °F		N/A

Haynes Manufacturing Company 24142 Detroit Road Westlake, Ohio 44145
 U.S.A. & Canada: 1-800-992-2166 Phone: 440-871-2188 Fax: 440-871-0855
<http://www.haynesmfg.com>

VIEW IN STAND BY, "RUN MODE"

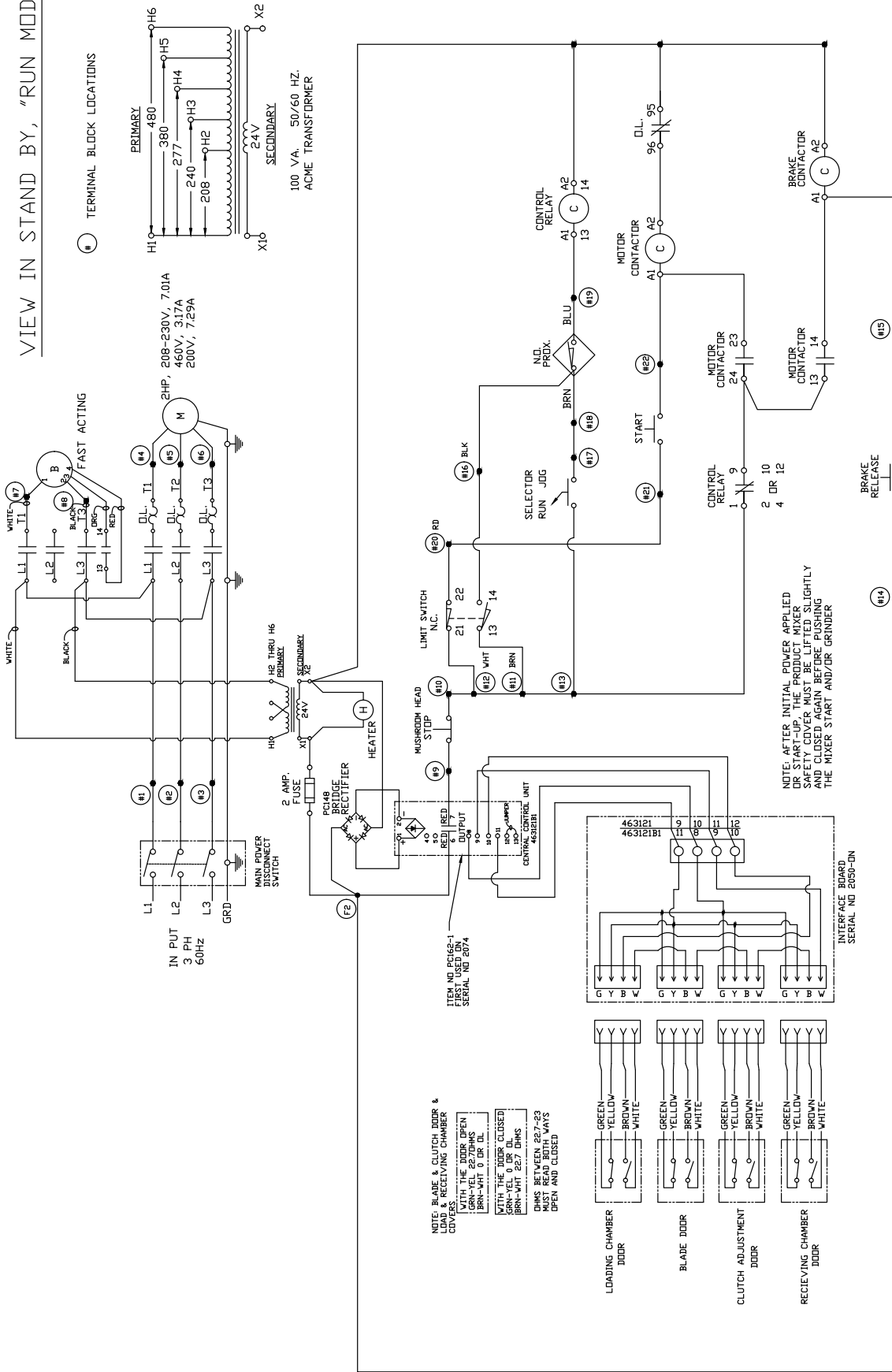

① TERMINAL BLOCK LOCATIONS

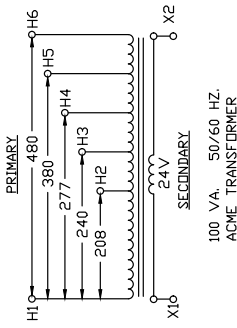

NOTE: BLADE & CLUTCH DOOR & LOADING & RECEIVING CHAMBER COVERS MUST BE OPEN TO START THE MIXER
 OPEN: GRN-YEL 22.7DHMS
 BRN-WHT 0 DR DL
 WHEN THE MIXER IS CLOSED
 GRN-YEL 0 DR DL
 BRN-WHT 22.7 DHMS
 DHMS BETWEEN 22.7-23 OPEN AND CLOSED

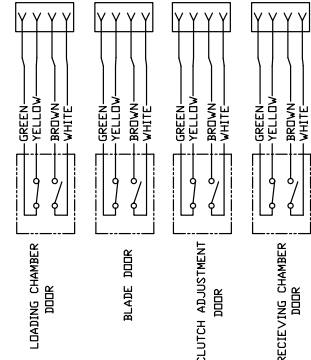

NOTE: AFTER INITIAL POWER APPLIED OR START-UP, THE PRODUCT MIXER SAFETY COVER MUST BE LIFTED SLIGHTLY AND CLOSED AGAIN BEFORE PUSHING THE MIXER START AND/OR GRINDER

MODEL 109PCM ELECTRIC SCHEMATIC
 SERIAL NO 2074-0N

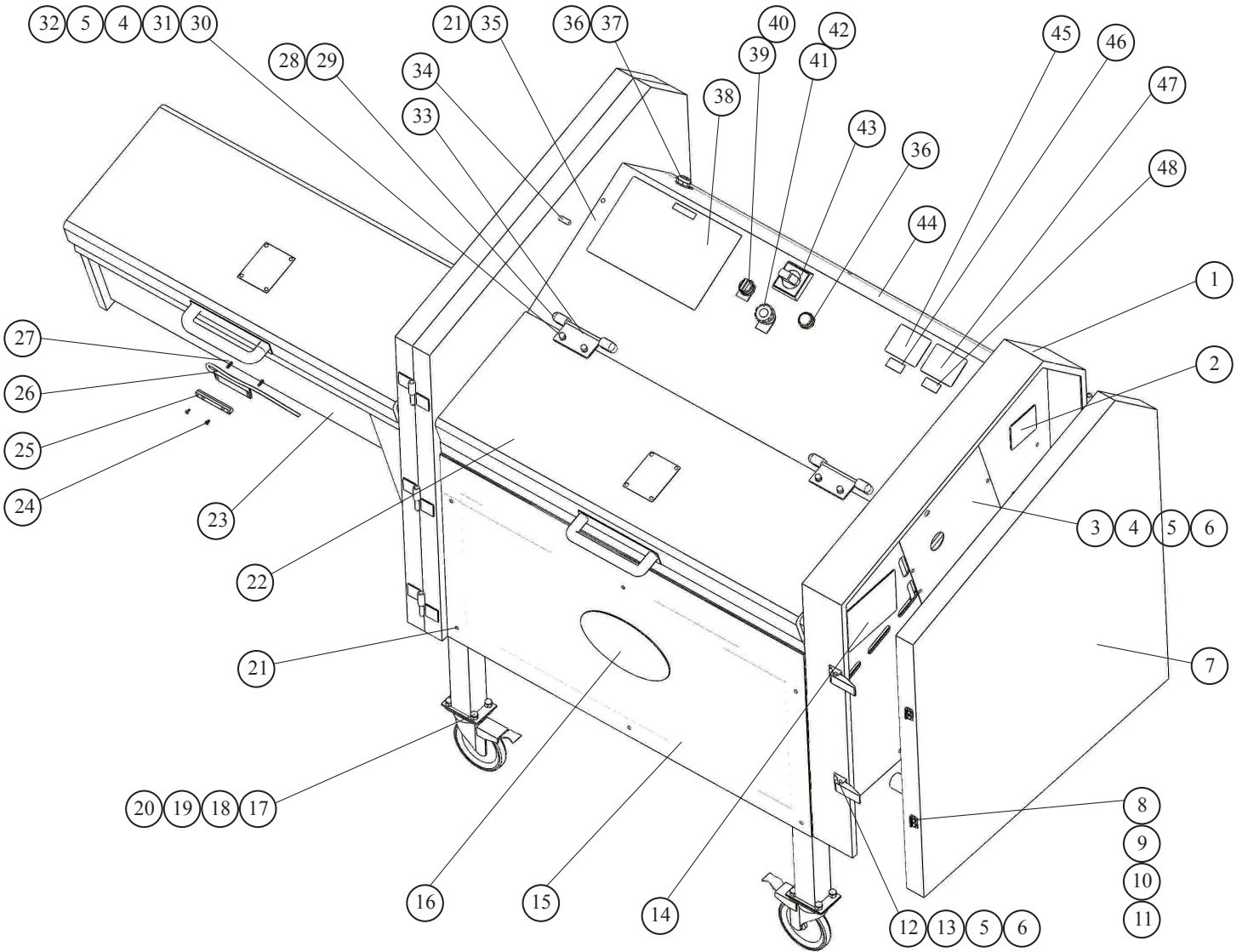
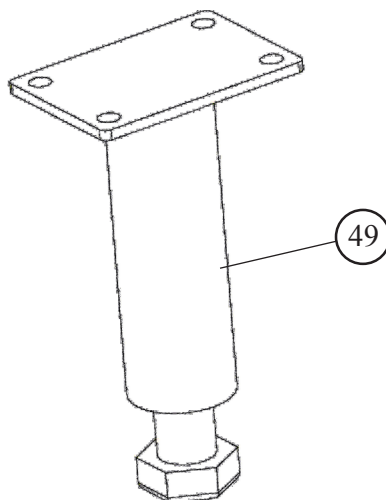

Fig.	Item Number	Description
1.	PCM511	Clutch frame door
2.	VT460S	Model & serial nameplate
3.	PCM568	Cover, RH holding plate
4.	FW06S	Flatwasher 1/4 SS
5.	LW10S	Lock washer 1/4 SS
6.	AN15S	Acorn nut SS 1/4-20
7.	PCM518	Clutch door
8.	PC390	Keeper, latch, SS
9.	HHS010S	Hex head screw 10-32 x 3/8 SS
10.	LW05S	Lock washer #10 SS
11.	HN10S	Hex nut 10-32 SS
12.	42MC-Y71SOU	Hold down latch SS
13.	CB60S	Carriage bolt, 1/4-20 x 1/2 SS
14.	PCM632	Label, thickness range scale
15.	PCM517	Front panel
16.	VTS7181	Biro world decal
17.	PC175-1	Caster, 5" dia, total lock swivel
18.	HHS055S	Hex head screw 5/16-18 x 3/4 SS
19.	LW15S	Lock washer 5/16 SS
20.	272-8	Acorn nut 5/16-18 SS
21.	HHS025S	Hex head screw 1/4-20 x 1/2 SS
22.	PCM646	Loading chamber cover assembly
23.	PCM524	LH door & recv chamber
24.	FHS05S	Flat head screw 8-32 x 5/16
25.	PC012	Tray safety switch spacer
26.	PC168	Loading & receiving chamber switch
27.	RHS073S	Round head screw 8-32 x 1/2 SS
28.	PC038-1	Connecting plate
29.	AN15S	Acorn nut 1/4-20 SS
30.	T3067	Safety cover hinge
31.	14593	Belleville spring SS washer
32.	HN15S	Hex nut 1/4-20 SS
33.	PC035	Chamber cover hinge & hinge pin
34.	PC178	Chamber cover bumper
35.	PCM537	Top panel
36.	PC154	Brake release switch
37.	PC031	Legend plate, brake release
38.	PCM621	Label, warning & operating
39.	31-50-S10	Jog switch
40.	PCM622	Name plate, run-jog
41.	PC155-1	Emergency stop switch
42.	PC156-1	Legend plate, emergency stop
43.	PC157	Main power switch
44.	PCM521	Rear panel
45.	653PS	Warning label
46.	42MC-665	Label, wired for 3 phase
47.	653SP	Warning label, Spanish
48.	42MC-656	Voltage label, wired 208V

OPTION

Stationary Foot



Leg extension

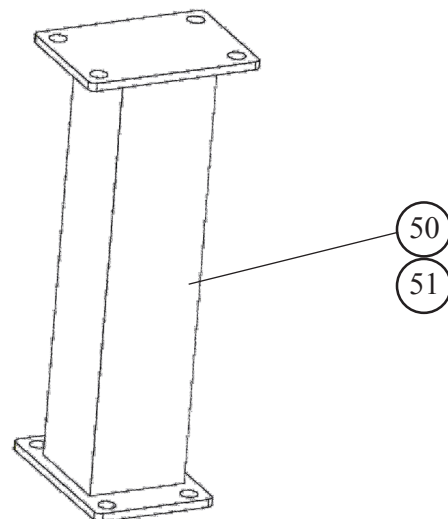

Fig.	Item Number	Description
49.	PC087	Stationary foot
50.	PC250	Leg extension, 7 1/2"
51.	PC200	Leg extension, 9"

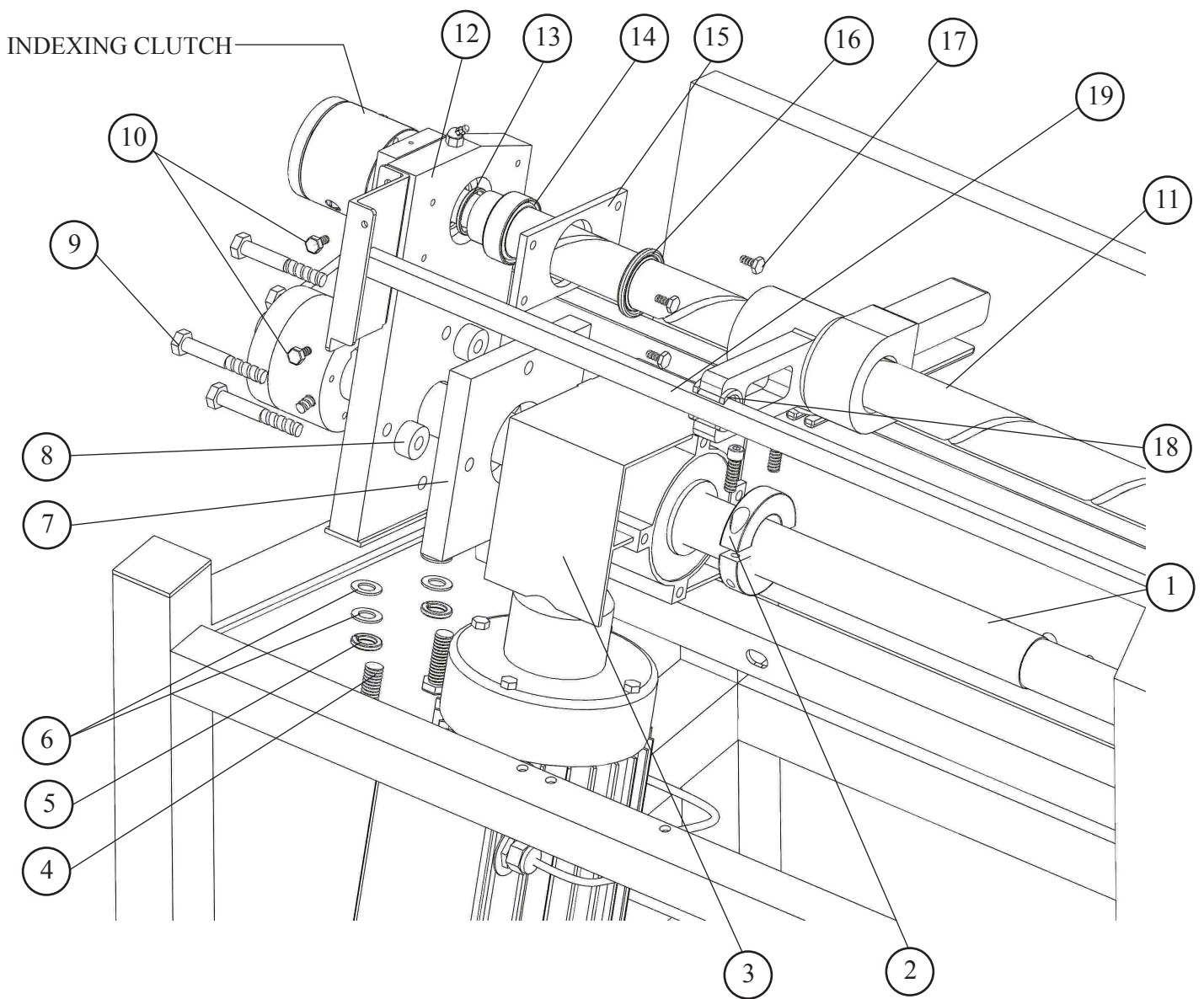

Fig. Item Number Description

1.	PCM572	Shaft, knife drive	10.	HHS049S	Hex head screw $5/16-18 \times 1/2$ SS
2.	PCM631	Locking collar, 2 pc. $1\frac{5}{8}$ "	11.	PCM571	Feed screw, product pusher
3.	PCM522	Gearmotor w/ brake 2HP	12.	PCM552	Holding plate, rh
4.	HHS127S	Hex head screw $1/2-13 \times 1\frac{1}{2}$ SS	13.	PCM554	Spacer, feed screw shaft, rh
5.	LW30S	Lock washer $1/2$ SS	14.	PCM565	Angular contact bearing, 25mm
6.	FW11S	Flat washer $1/2$ SS	15.	PCM551	Seal & bearing cap, rh holding plate
7.	PCM546	Spacer, gearmotor w/brake	16.	PCM553	Seal, feed screw shaft, rh side, G40 x 52 x 5
8.	PCM608	Spacer, gearmotor w/brake, 1" dia	17.	HHS025S	Hex head screw $1/4-20 \times 1/2$ SS
9.	HHSM068	Hex head screw, m10 x 1.5 x 70 mm, STL plated	18.	PCM587	Guide bushing, product pusher handle
			19.	PCM558	Slide bar assembly

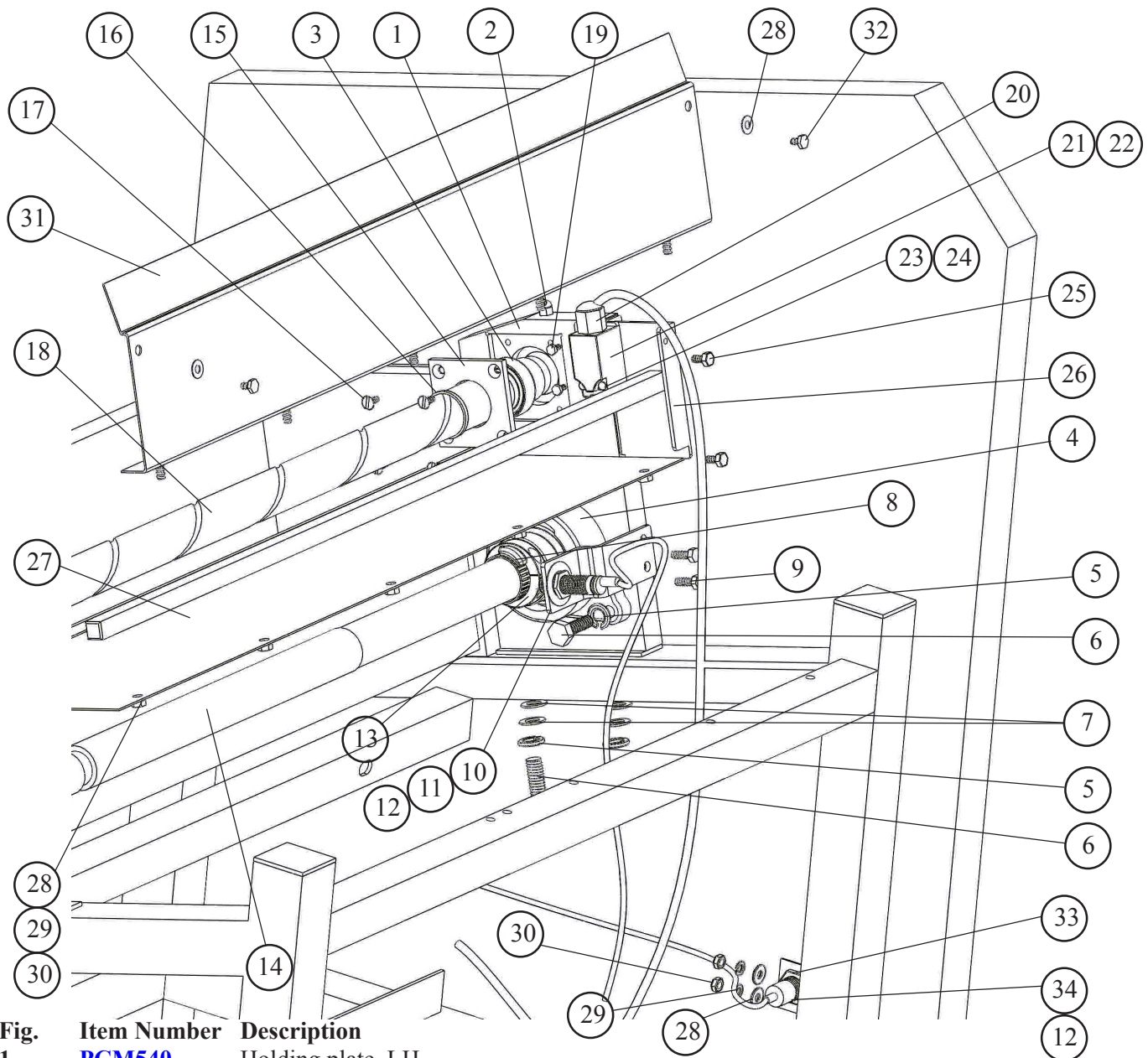

Fig.	Item Number	Description
1.	PCM540	Holding plate, LH
2.	360A1	Angle grease fitting
3.	PCM565	Angular contact bearing, 25 mm
4.	PCM541	Bearing, 2 bolt flange, 1½ bore
5.	LW30S	Lock washer ½ SS
6.	HHS127S	Hex head screw ½-13 x 1½
7.	FW11S	Flat washer ½ SS
8.	PC198	Hose clamp
9.	HHS049S	Hex head screw 5/16-18 x ½ SS
10.	PCM543	Mounting bracket, prox. switch
11.	PCM590	Proximity switch, knife blade shaft
12.	226-28	Washer SS 1½ x 27/32
13.	PCM542	Locking collar, 2 pc. 1¾"
14.	PCM572	Shaft, knife drive
15.	PCM539	Seal/bearing cap, holding plate LH
16.	PCM544	Seal, feed screw shaft, LH side
17.	FHS33S	Flat head screw ¼-20 x ½ SS
18.	PCM571	Feed screw, product pusher
19.	HHS010S	Hex head screw 10-32 x ¾ SS
20.	VTS7130	Cord strain relief
21.	PCM559	Spacer, limit switch
22.	PCM591	Limit switch, product pusher
23.	RHS21S	Round head screw 10-32 x 1¼ SS
24.	LW05S	Lock washer #10 SS
25.	HHS049S	Hex head screw 5/16-18 x ½ SS
26.	PCM558	Slide bar assembly
27.	PCM562	Splash guard bottom
28.	FW06S	Flat washer ¼ SS
29.	LW10S	Lock washer ¼ SS
30.	HN15S	Hex nut ¼-20 SS
31.	PCM563	Splash guard back
32.	HHS020S	Hex head screw ¼-20 x ¾ SS
33.	PC044	Mount, switch door
34.	PC166	Door safety switch

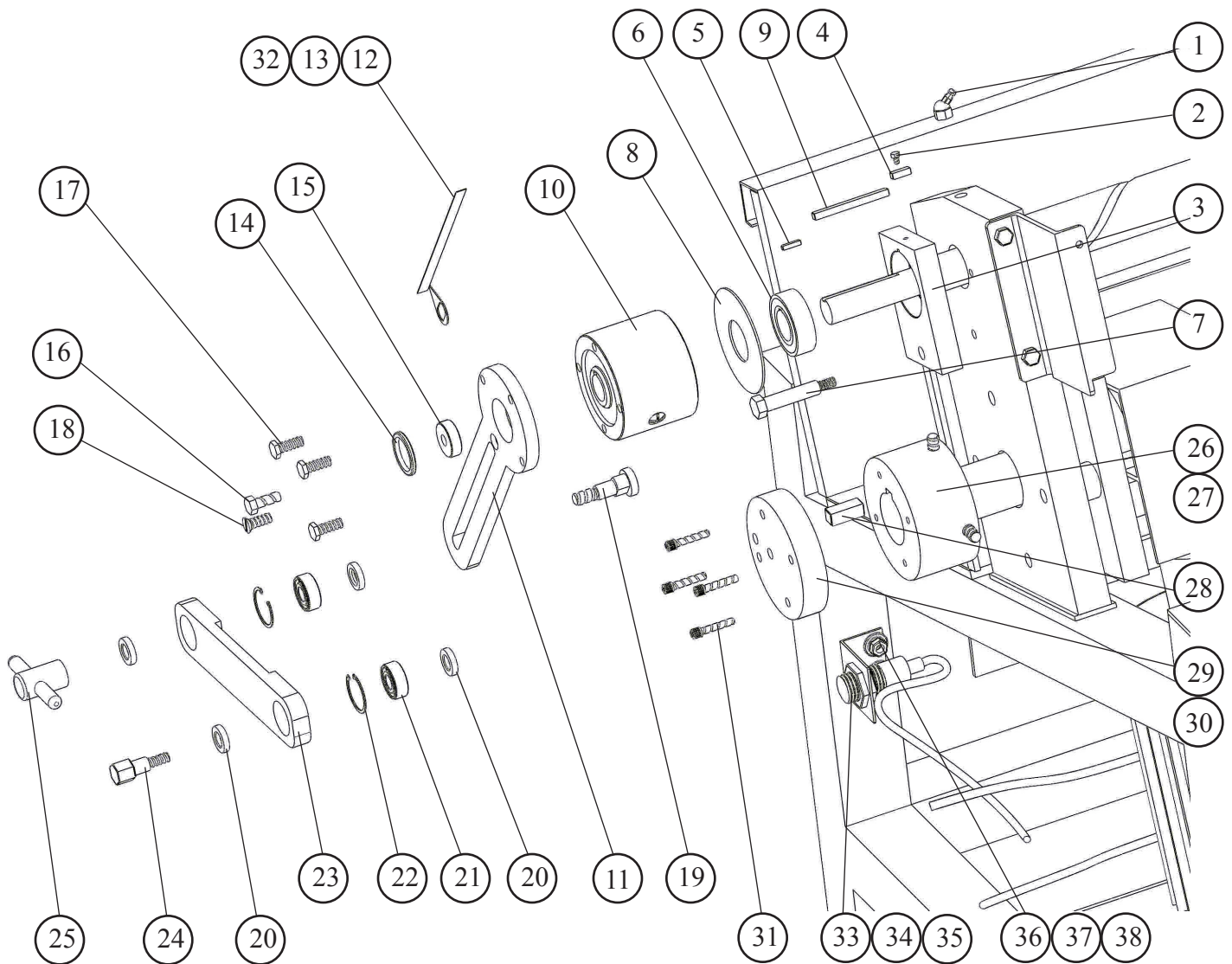

Fig.	Item Number	Description
	1.	360A1 Angle grease fitting
	2.	HHS005S Hex head screw 8-32 x 1/2 SS
	3.	PCM614 Housing, backstopping clutch
	4.	PCM623 Key, backstopping clutch
	5.	PCM615 Key, 3mm, backstopping clutch
	6.	PCM617 Clutch, backstopping, 20mm bore
	7.	SSB40S-2 Shoulder bolt, 5/16-18 x 1.56 SS
	8.	PCM611 Spacer, backstopping clutch
	9.	PCM616 Key, indexing clutch
	10.	PCM561 Clutch, indexing
	11.	PCM567 Linkage arm, indexing clutch
	12.	PCM603 Label, product slice thickness
	13.	PCM620 Indicator, product thickness
	14.	PCM564 Seal, feed screw shaft, rh side G25 x 32 x4
	15.	PCM599 Cap, product pusher feed screw
	16.	HHS055S Hex head screw, 5/16-18 x 3/4 SS
	17.	HHS043S Hex head screw, 1/4-28 x 3/4 SS
	18.	FHS360S Flat head screw, 1/4-28 x 3/4 SS
	19.	PCM595 Locking bolt, Linkage arm
	20.	PCM596 Spacer, draw arm
	21.	31-14-01 Ball bearing
	22.	31-14-02 Locking ring
	23.	31-14 Draw lever
	24.	PCM607 Shoulder bolt, eccentric hub cap
	25.	PCM600 Adjustment handle, linkage arm
	26.	SSS30S Set screw 3/8-16 x 3/4 cup pt. SS
	27.	PCM613 Hub, eccentric 1.80 LG
	28.	PCM592 Key, eccentric hub
	29.	PCM588 Hub cap, eccentric
	30.	PCM630 Hub cap, eccentric .042 min. thk
	31.	SHS042S Socket head cap screw 1/4-20 x 1 SS
	32.	PCM625 Label, product slice thickness mm
	33.	PC166 Door safety switch
	34.	226-28 Washer SS 1 1/2 x 27/32
	35.	PC044 Mount, switch door
	36.	FW06S Flat washer, 1/4 SS
	37.	LW10S Lock washer, 1/4 SS
	38.	HN15S Hex nut, 1/4-20 SS

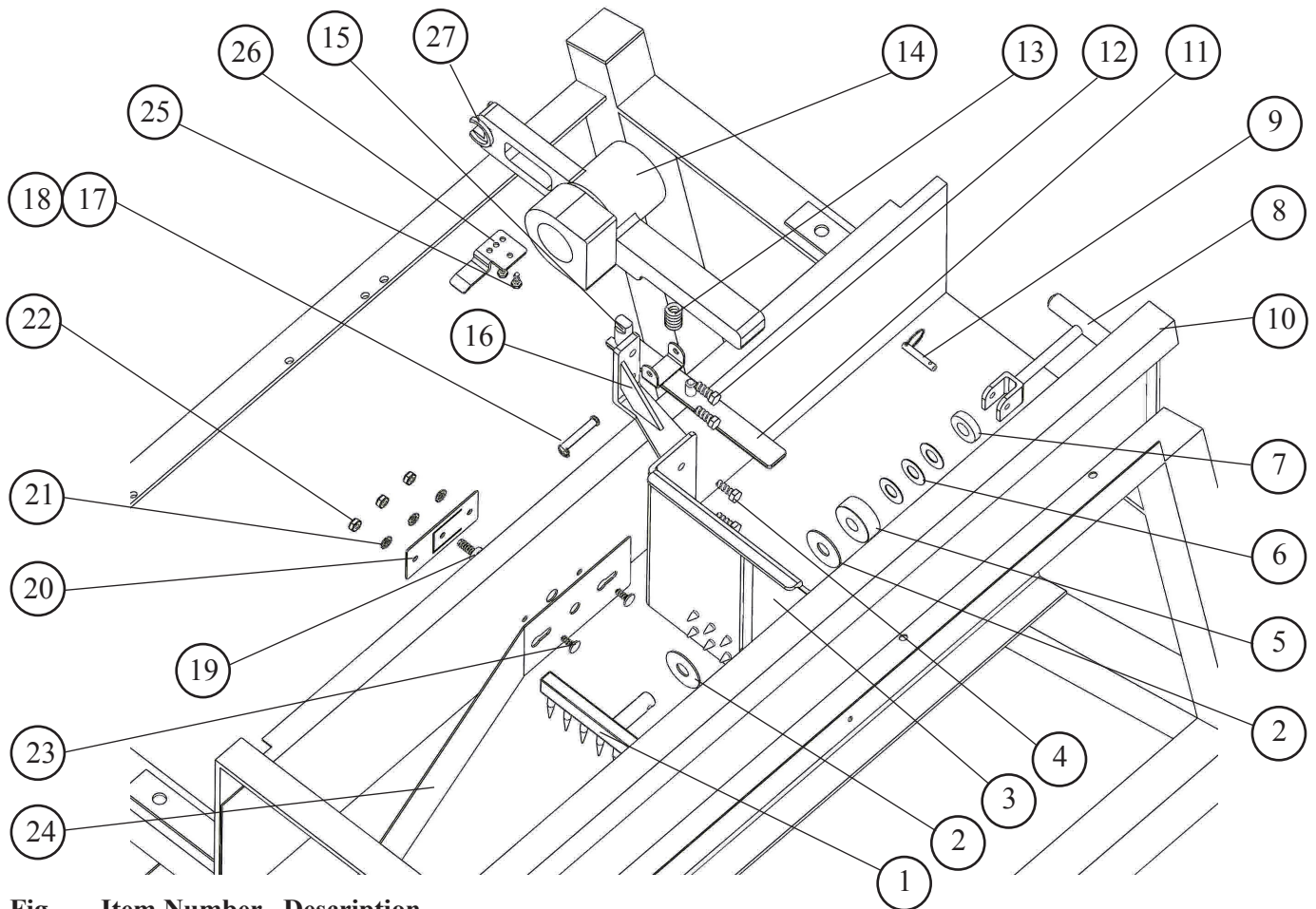
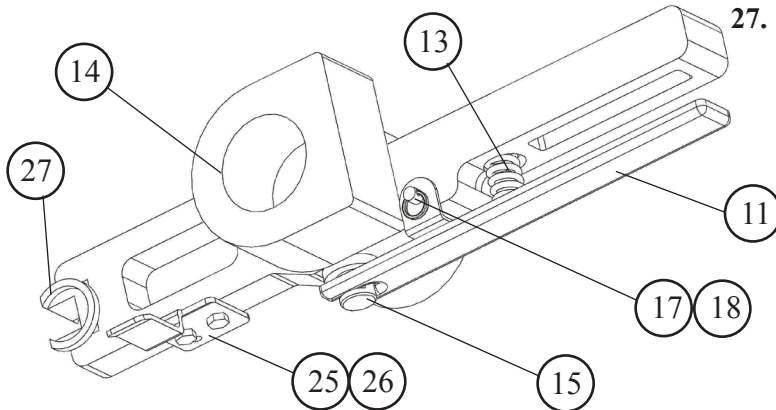
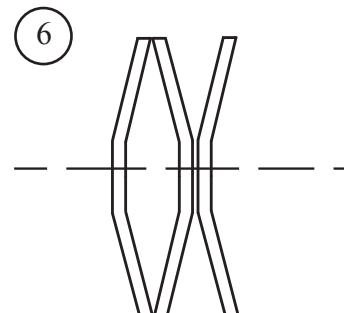

Fig.	Item Number	Description
1.	PC080	Gripper
2.	PC005	Slide washer
3.	PCM619	Product pusher
4.	HHS049S	Hex head screw $5/16-18 \times 1/2$ SS
5.	PC003	Spring housing
6.	PC132	Belleville disc spring
7.	PC024	Thrust washer
8.	PC086	Handle
9.	PC025	Faspin
10.	PCM508	Frame w/ loading tray/frame door
11.	PCM579	Lever assembly, product pusher
12.	HHS055S	Hex head screw $5/16-18 \times 3/4$ SS
13.	PCM584	Lever spring, product pusher
14.	PCM574-1	Handle casting, product pusher
15.	PCM577	Pin, feed screw, product pusher
16.	PCM569	Mounting bracket, product pusher
17.	PCM585	Pivot pin, product pusher
18.	PCM586	Split ring, pivot pin, product pusher
19.	PC032	Product deflector release pin
20.	PC034	Fastener plate, product deflector
21.	LW10S	Lock washer $1/4$ SS
22.	HN15S	Hex nut $1/4-20$ SS
23.	PC033	Product deflector key hole stud
24.	PC103	Side product deflector
25.	HHS010S	Hex head screw $10-32 \times 3/8$ SS
26.	PCM560	Actuator limit switch
27.	PCM587	Guide bushing, product pusher handle



Product Pusher Handle Assembled



Belleville Disc Spring Assembly

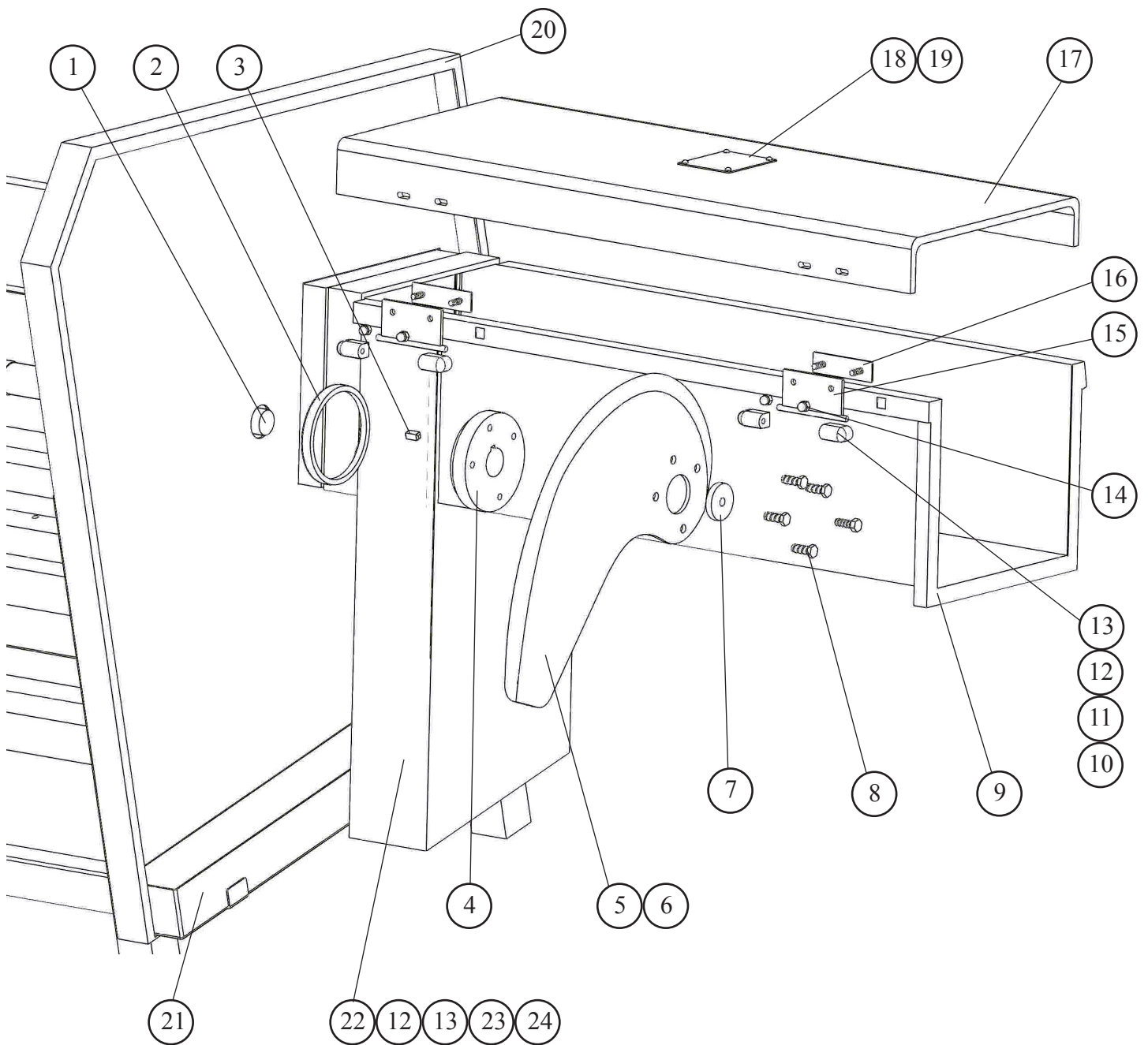

Fig.	Item Number	Description
1.	PCM572	Shaft, knife drive
2.	PC078	Blade shaft seal
3.	PC018	Key, $\frac{5}{16} \times \frac{5}{16} \times \frac{3}{4}$, blade mounting plate
4.	PC050	Blade mounting plate
5.	PC124	Blade, Smooth
6.	PC125	Blade, Serrated
7.	PC023	Cap, blade mounting plate
8.	HHS070S	Hex head screw $\frac{3}{8}$ -16 x 1 SS
9.	PCM524	LH door & recv chamber
10.	T3067	Safety cover hinge
11.	FW06S	Flat washer, $\frac{1}{4}$ SS
12.	LW10S	Lock washer, $\frac{1}{4}$ SS
13.	HN15S	Hex nut $\frac{1}{4}$ -20 SS
14.	AN15S	Acorn Nut $\frac{1}{4}$ -20 SS
15.	PC035	Chamber cover hinge & hinge pin
16.	PC038-1	Connecting plate
17.	PC229	Receiving chamber cover assembly
18.	PC270	Warning label, sharp knife blade
19.	375	Drive screw SS
20.	PCM508	Frame w/loading tray & frame door
21.	PC071	Surplus catch tray
22.	PCM525	Support bracket, receiving chamber
23.	PC161	Strain relief fitting
24.	241-LN	Lock nut, $\frac{1}{2}$ conduit

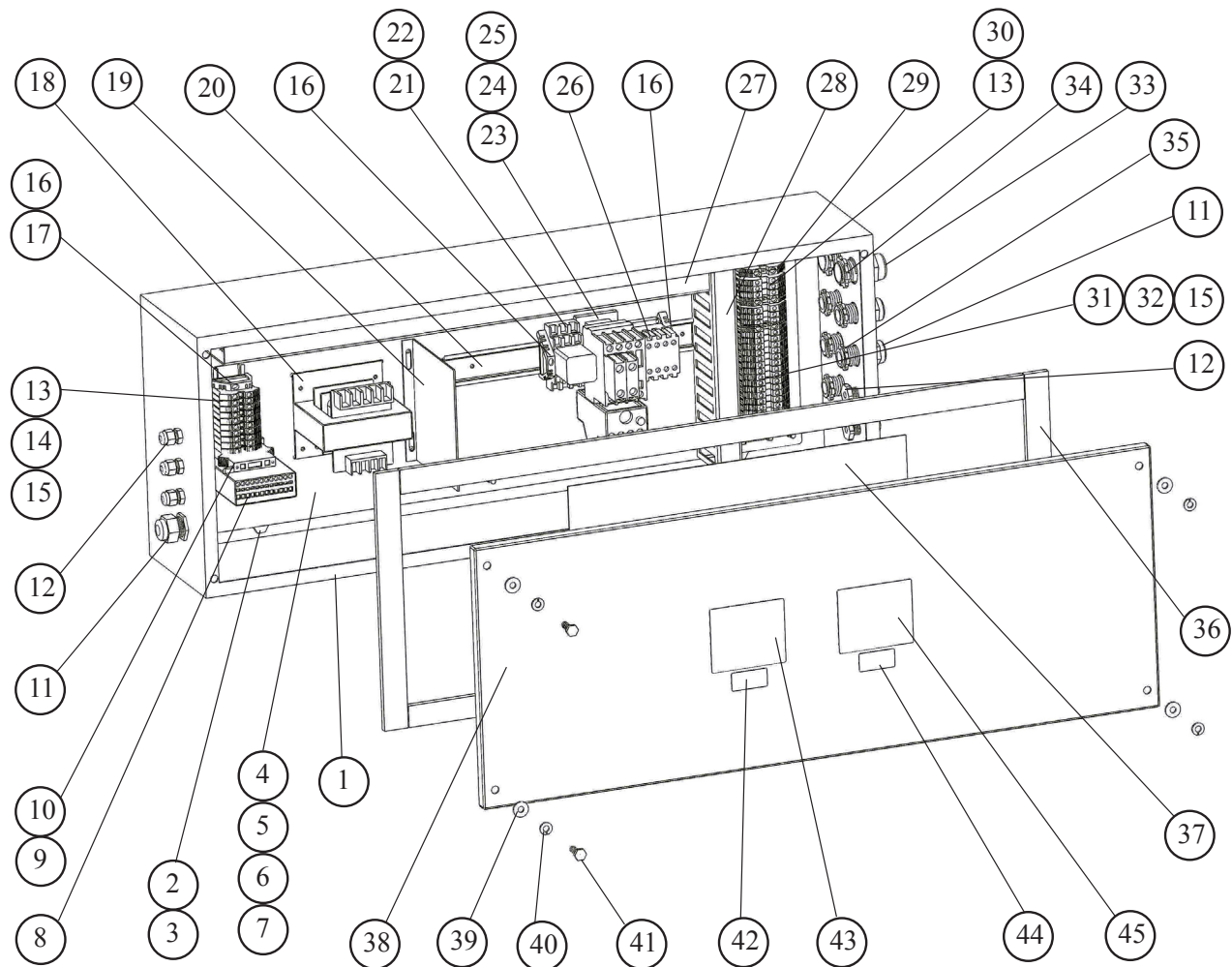
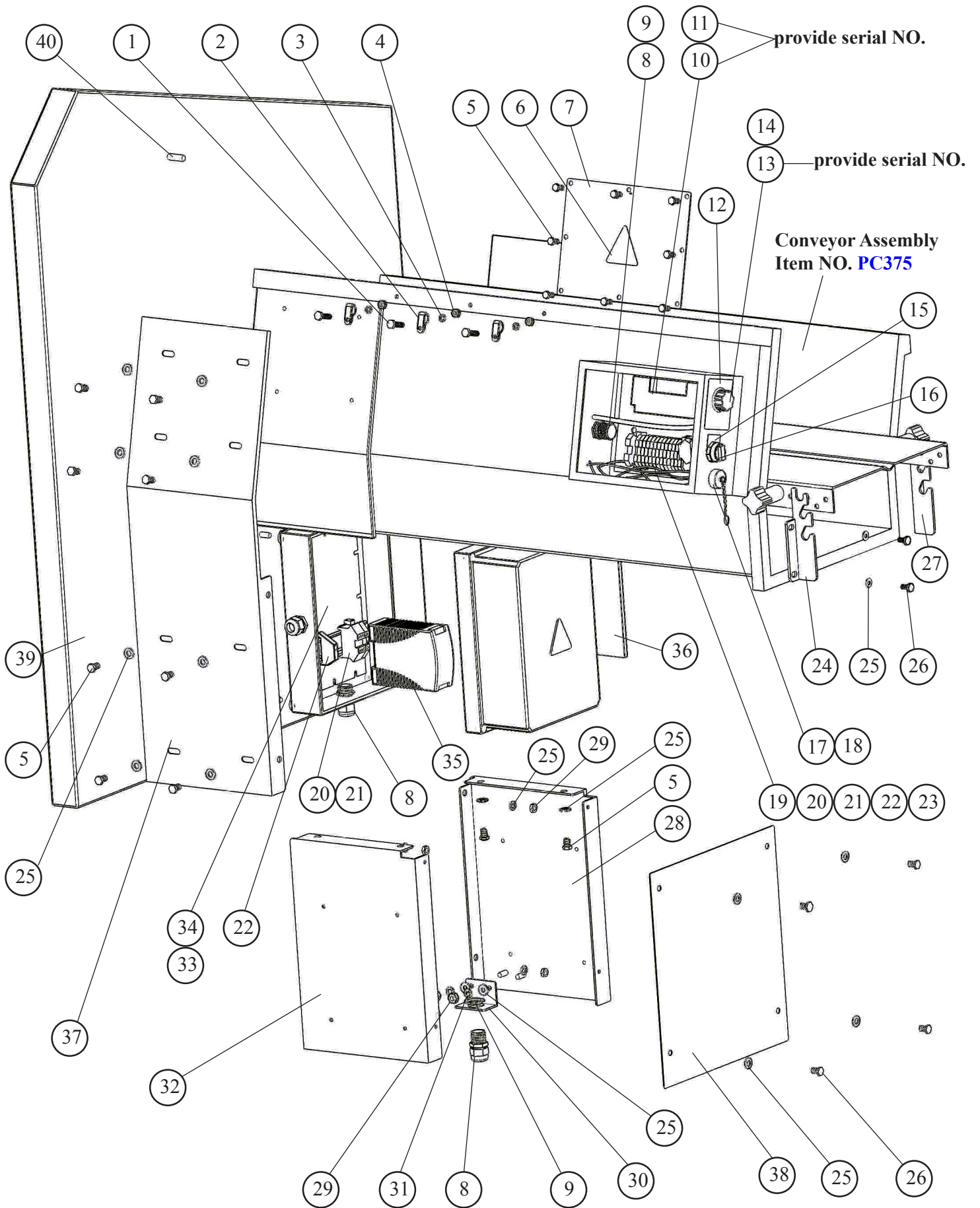

Fig.	Item Number	Description		
	1.	PCM514	Control box	23. PC144-1 Contactor, 24V
	2.	HHS060S	Hex head screw ⁵ / ₁₆ -18 x 1	24. PC146-1 Aux contact, NO.
	3.	HN20S	Hex nut ⁵ / ₁₆ -18 SS heavy	25. 226EE-OL08.5L Overload B18K-L, 5.5-8.5A
	4.	PCM516	Component plate, control box	26. 226EE-GO Contactor LS05.10-GO, 24V
	5.	HHS040S	Hex head screw ¹ / ₄ -20 x ³ / ₄ SS	27. PCM530 Wire raceway, 20 ¹ / ₂
	6.	HN15S	Hex nut ¹ / ₄ -20 SS	28. PCM529 Wire raceway, 8 ⁷ / ₈
	7.	LW10S	Lock washer ¹ / ₄ SS	29. BLK322 Ground block
	8.	PC162	Central control unit	30. PCM527 Din rail, terminal block, 8 ³ / ₄
	9.	EMG92014	Fuse block, din rail type	31. EMG92015 Internal jumper, 3 pole
	10.	VTS7177	Fuse, 2 AMP	32. PCM536 Internal jumper, 4 pole
	11.	PC161	Strain relief fitting, ⁷ / ₈ dia	33. PC281 Strain relief, ³ / ₄
	12.	PC159	Strain relief fitting, ¹ / ₂ dia	34. 241-LN1 Lock nut, ³ / ₄
	13.	PC152	Terminal	35. 241-LN Lock nut, ¹ / ₂
	14.	VTS582	End plate, terminal block	36. 14535 Gasket ³ / ₁₆ x 1, density foam tape
	15.	PC257	Internal jumper, 6mm, terminal	37. PCM519 Wire diagram
	16.	BLK323	End barrier	38. PCM515 Cover, control box
	17.	PCM526	Din rail, central control, 5 ¹ / ₄	39. FW06S Flat washer, ¹ / ₄ SS
	18.	63026	Transformer, 208-460/24 V	40. LW10S Lock washer, ¹ / ₄ SS
	19.	PC158	Heater, 24V w/thermostat	41. HHS040S Hex head screw, ¹ / ₄ -20 x ³ / ₄ SS
	20.	PCM528	Din rail, contactors, 10 ³ / ₈	42. 42MC-665 Label, wired for 3 phase
	21.	60067	Base, relay 3PDT	43. 653PS Warning Label
	22.	60066	Relay, 3PDT, 24V	44. 42MC-656 Voltage label, wired 208V
				45. 653SP Warning label, spanish

NOT SHOWN

PC148	Bridge rectifier
PC162-1	Central control unit, 24V s/n req'd
VTS582	End plate, terminal block



109PCM CONVEYOR OPTIONS

Fig.	Item Number	Description
1.	HHS010S	Hex head screw 10-32 x $\frac{3}{8}$ SS
2.	VTS7131	Wire clamp
3.	LW05S	Lock washer #10 SS
4.	HN10S	Hex nut 10-32 SS
5.	HHS020S	Hex head screw $\frac{1}{4}$ -20 x $\frac{3}{8}$ SS
6.	BES16971	Label, risk of electrical shock
7.	PC327	Cover, conveyor electrical encl
8.	PC161	Strain relief fitting
9.	241-LN	Lock nut, $\frac{1}{2}$ conduit
10.	PC384	Driver card, CB-07, power roller
11.	PC384-1	Driver card, CB-008S, power roller
12.	VT485S	Label, speed control
13.	PC388	Potentiometer & 17 $\frac{3}{4}$ cable assy w/resistor
14.	VTS7174	Knob, potentiometer
15.	PC324	Legend plate, conveyor off-on
16.	PC323	Selector switch, 2-position maintain
17.	PC321	Receptacle, 12-pin, male thd
18.	PC322	Closure cap, 12-pin receptacle
19.	BLK313	Din rail, 6" LG
20.	PC152	Terminal
21.	BLK322	Ground terminal
22.	BLK323	End barrier
23.	PC325	Subplate, conveyor control enclosure
24.	PC367	Hanger, RH
25.	FW06S	Flat washer, $\frac{1}{4}$ SS
26.	HHS025S	Hex head screw $\frac{1}{4}$ -20 x $\frac{1}{2}$
27.	PC366	Hanger, LH
28.	PCM639	Left support, receiving chamber
29.	HN15S	Hex nut $\frac{1}{4}$ -20 SS
30.	PC336	Mounting bracket, strain relief
31.	LW10S	Lock washer $\frac{1}{4}$ SS
32.	PCM640	Right support, receiving chamber
33.	PC406	Water tight enclosure, conv OPT
34.	PC407	Subplate, electrical enclosure
35.	PC318-2	Power supply, 24 vdc, input 100-240v, 60 watt
36.	PCM642	Left cover, receiving chamber support
37.	PCM643	Right cover, receiving chamber support
38.	PCM641	Front cover, receiving chamber support
39.	PCM636	LH door & receiving chamber
40.	PC178	Chamber cover bumper

CONVEYOR ASSEMBLY W/O
ELECTRICAL CONTROL

ITEM NO. PC375

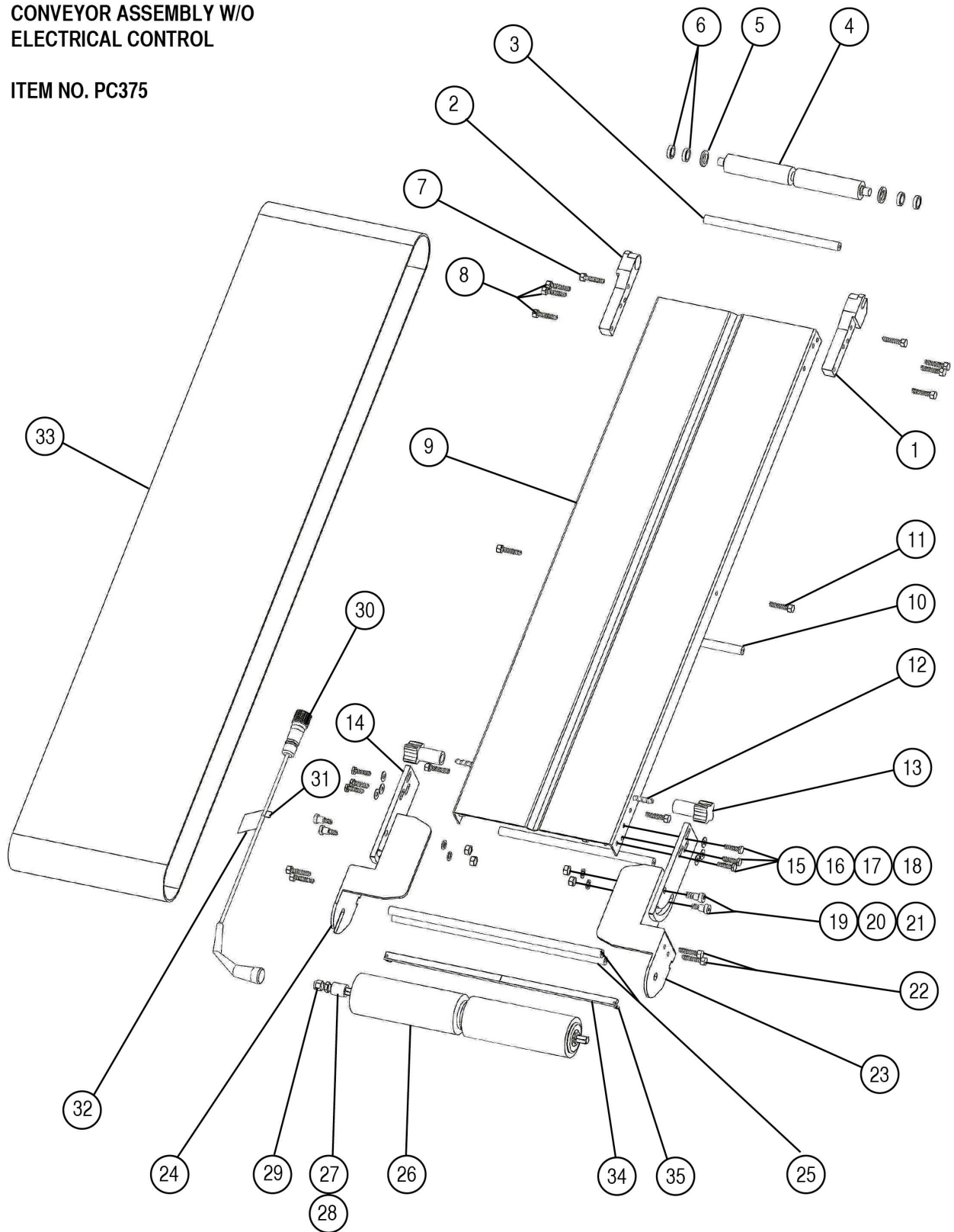

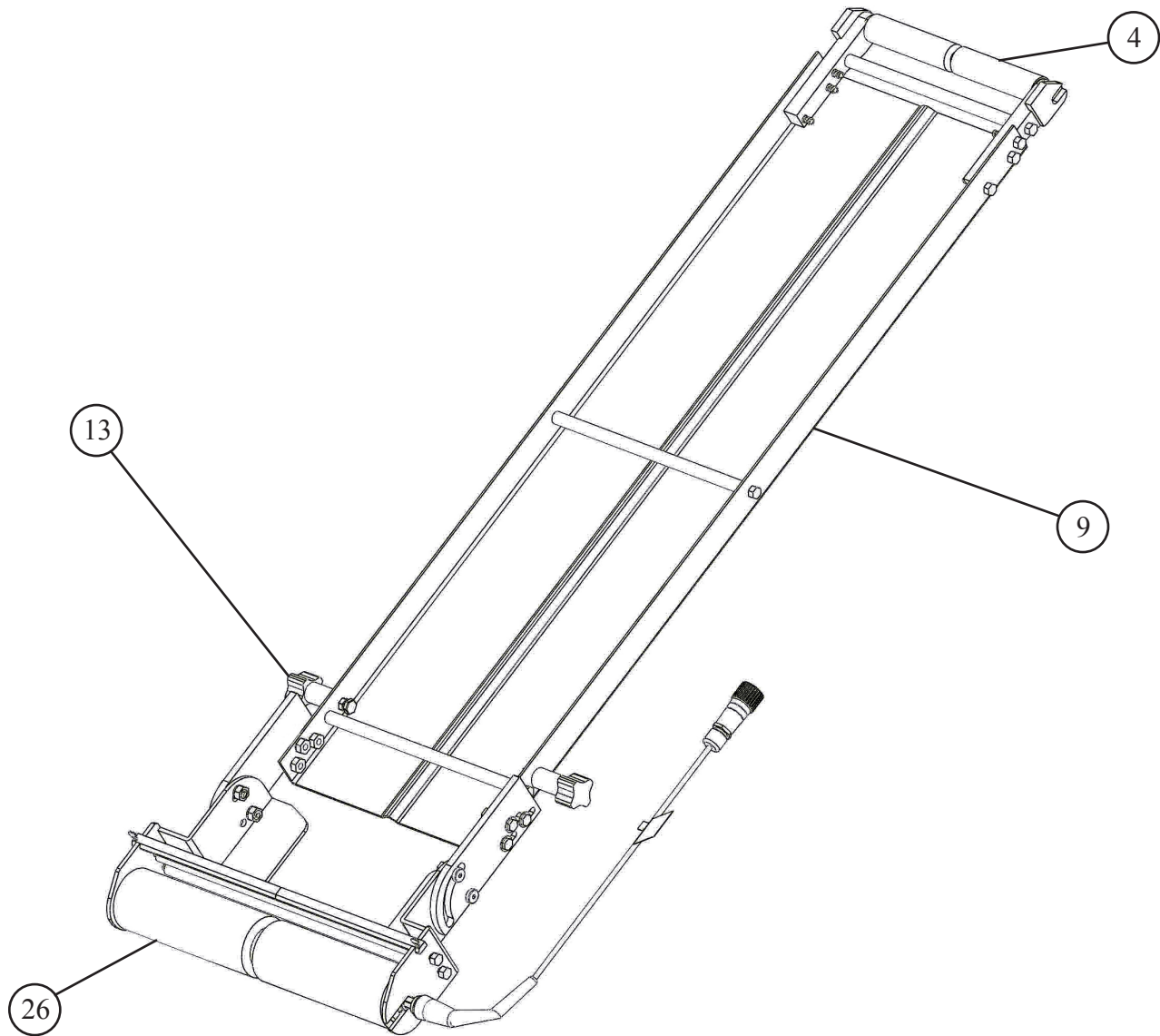

Fig.	Item No.	Description	Fig.	Item No.	Description
1.	PC354	Fixed Idle End, LH	19.	SSB40S	Shoulder Bolt, ⁵ / ₁₆ -18 x ³ / ₈ , SS
2.	PC353	Fixed Idle End, RH	20.	LW15S	Lock Washer, ⁵ / ₁₆ SS
3.	PC357	Spacer, Fixed Idle End	21.	HN20S	Hex Nut, ⁵ / ₁₆ -18 SS
4.	PC358	Nose Roller, Idle End	22.	HHS025S	Hex Head Screw ¹ / ₄ -20 x ¹ / ₂ SS
5.	PC356	Seal, Conveyor Idle Side	23.	PC316	Drive Tension Bracket, RH
6.	PC355	Bearing, 12mm x21mm x5mm	24.	PC317	Drive Tension Bracket, LH
7.	HHS046S	Hex Head Screw ¹ / ₄ -20 x1 SS	25.	PC352	Spacer, Drive End
8.	HHS040S	Hex Head Screw ¹ / ₄ -20 x ³ / ₄ SS	26.	PC314	Power Roller, 2 ¹ / ₂ OD x14.41LG
9.	PC315	Bed, Conveyor	27.	PC386	Strain Relief, Power Roller
10.	PC351	Spacer, Conveyor Bed -2 Req'd	28.	SSS025S	Set Screw 8-32 x ³ / ₁₆ SS -2 Req'd
11.	HHS025S	Hex Head Screw ¹ / ₄ -20 x ¹ / ₂ SS	29.	PC159	Strain Relief Fitting
12.	HHS083S	Hex Head Screw ³ / ₈ -16 x1 ³ / ₄ SS	30.	PC320	Male Contact Holder, Female Thd
13.	291-1	Knob, 2 ⁵ / ₁₆ Long	31.	PC369	Wire Tie, Yellow Marker Tie
14.	PC350	Pivot Mounting Plate, Conveyor	32.	PC419	Label, Drive Roller Instructions
15.	HHS040S	Hex Head Screw ¹ / ₄ -20 x ³ / ₄ SS	33.	PC359	Conveyor Belt, 10" Wide x 97 ⁷ / ₈ "
16.	FW06S	Flat Washer, ¹ / ₄ SS	34.	PC368	Wiper, Drive Bottom
17.	LW10S	Lock Washer, ¹ / ₄ SS	35.	TS010S	Thumb Screw, 10-32 x ¹ / ₂ SS -2 Req'd
18.	HN15S	Hex Nut, ¹ / ₄ -20 SS			

RECOMMENDED SPARE PARTS LIST

QTY	ITEM NO.	DESCRIPTION
2	PC005	SLIDE WASHER, PRODUCT PUSHER
1	PC025	FASPIN, PRODUCT PUSHER
1	PC078	BLADE SHAFT SEAL
1	PC124	BLADE, SMOOTH
1	PC125	BLADE, SERRATED
3	PC132	BELLEVILLE DISC SPRING
1	PCM591	LIMIT SWITCH
2	PCM596	SPACER, DRAW ARM
1	VTS7177	FUSE, 2A
2	31-14-01	BEARING

OPERATOR'S NOTES

LIMITED WARRANTY:

WARRANTY: The BIRO Manufacturing Company warrants that Model 109PCM Horizontal Slicer will be free from defects in material and workmanship under normal use and with recommended service. BIRO will replace defective parts, which are covered by this limited warranty, provided that the defective parts are authorized for return, shipping charges prepaid, to a designated factory for inspection and/or testing.

DURATION OF WARRANTY: The warranty period for all parts covered by this limited warranty is one (1) year from date of Inspection/Demonstration advised on the returned Warranty Registration Card, or eighteen (18) months from original factory ship date, whichever occurs first, except as noted below.

PARTS NOT COVERED BY WARRANTY: The following are **NOT** covered by this limited warranty: Smooth blade (Item No. [PC124](#)), Serrated blade (Item No. [PC125](#)), Side product deflector (Item No. [PC103](#)). This limited warranty does not apply to machines sold as used, rebuilt, modified, or altered from the original construction in which the machine was shipped from the factory. (WATER CONTAMINATED ELECTRICAL SYSTEMS ARE NOT COVERED UNDER THIS LIMITED WARRANTY.) BIRO is not responsible for electrical connection of equipment, adjustments to switch gear or any other electrical requirements, which must be performed only by a certified electrician. BIRO is not responsible for service charges or labor required to replace any part covered by this limited warranty or for any damages resulting from misuse, abuse, lack of proper or recommended service.

EXCLUSION OF WARRANTIES AND LIMITATION OF REMEDIES: BIRO gives no warranties other than those expressly stated in this limited warranty. THE IMPLIED WARRANTY OF MERCHANTABILITY, THE IMPLIED WARRANTY OF FITNESS FOR PROCESSING OF FOOD PRODUCTS, AND ALL OTHER IMPLIED WARRANTIES ARE SPECIFICALLY EXCLUDED. BIRO IS NOT LIABLE FOR CONSEQUENTIAL OR INCIDENTAL DAMAGES, EXPENSES, OR LOSSES. THE REMEDIES PROVIDED IN THIS BIRO LIMITED WARRANTY ARE PURCHASER'S SOLE AND EXCLUSIVE REMEDIES AGAINST BIRO.

REGISTRATION CARDS: You must sign, date and complete the warranty registration card supplied with each machine. The warranty card must be returned to The BIRO Manufacturing Company for proper registration. If no warranty card is returned to BIRO, the warranty period will begin from the date the machine was originally shipped from the factory.

HOW TO GET SERVICE:

1. Contact the agency from whom you purchased the machine; or
2. Consult the yellow pages of the phone directory for the nearest authorized dealer; or
3. Contact Biro Manufacturing Company for the nearest authorized service entity in your area.

BIRO MANUFACTURING COMPANY

1114 West Main St.
Marblehead, OH 43440
Ph. 419-798-4451
Fax 419-798-9106
Service@birosaw.com
www.birosaw.com