



RESIDENTIAL GAS REPLACEMENT PARTS LIST

URGPV & ULGPV ECO Models



Models Covered:
URG1PV(40, 50)S*N
URG2PV(40, 50)T*N
URG2PV50H*N
ULG2PV50H56*N
URG2PV75H*N
ULG2PV75H76*N
***Denotes warranty year**

Effective: October, 2024
ECO 8780

**NOTE: BOTH MODEL AND SERIAL
NUMBERS ARE REQUIRED FOR
ORDERING REPLACEMENT PARTS**

Dimensions and specifications
subject to change without notice.

WARNING
CANCER AND REPRODUCTIVE HARM
WWW.P65WARNINGS.CA.GOV

As required by the state of California Proposition 65.

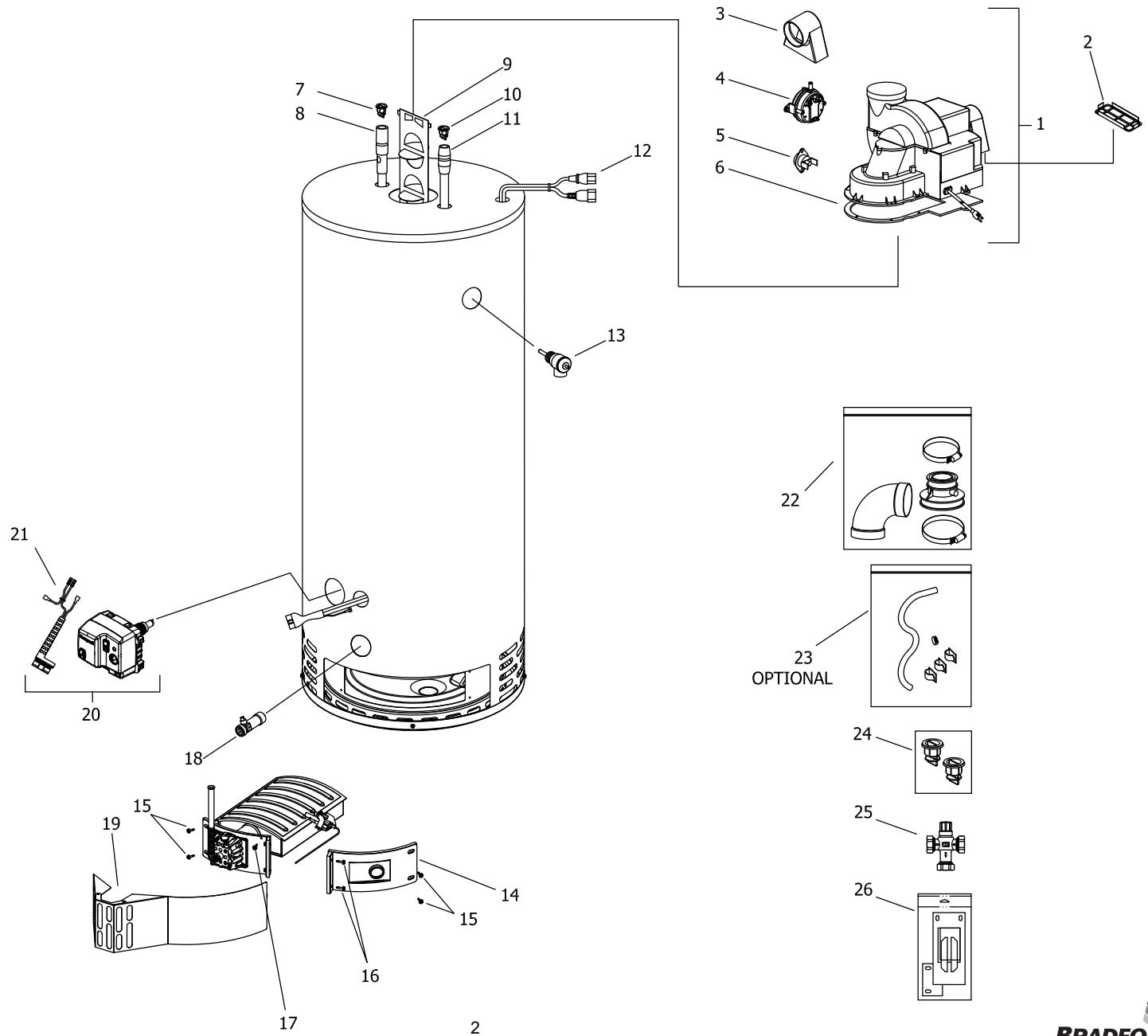

Item Description	Model	Model	Model	Model
	URG1PV40S*N	URG1PV50S*N	URG2PV40T*N	URG2PV50T*N
1 Blower Complete 0 Ft. to 2,000 Ft. (Normal Altitude)	415-45584-00	415-45584-00	415-48685-00	415-48685-00
Blower Complete 2,001 Ft. to 7,001 Ft. (High Altitude)	239-45987-00	239-45987-00	243-48686-00	243-48686-00
2 Dilution Air Clip	239-48176-00	239-48176-00	239-48176-00	239-48176-00
3 Air Mixing Inlet	239-45868-00	239-45868-00	239-45868-00	239-45868-00
4 Pressure Switch 0 Ft. to 2,000 Ft. (Normal Altitude)	415-45867-01	415-45867-01	415-47815-04	415-47815-03
Pressure Switch 2,001 Ft. to 7,000 Ft. (High Altitude)	415-47815-03	415-47815-03	415-47815-04	415-47815-04
5 Blower Temperature Switch	415-48752-00	415-48752-00	415-48752-00	415-48752-00
6 Blower Gasket	239-45866-00	239-45866-00	239-45866-00	239-45866-00
7 Heat Trap Insert (Outlet)	415-45167-00	415-45167-00	415-45167-00	415-45167-00
8 Hot Water Outlet Anode (Magnesium)▲ #	415-55482-00	415-55482-00	415-55482-00	415-55482-00
Hot Water Outlet Anode (Aluminum)▲#	415-55484-00	415-55484-00	415-55484-00	415-55484-00
Hot Water Outlet Anode (A420 Aluminum)▲ #	415-55486-00	415-55486-00	415-55486-00	415-55486-00
9 Flue Baffle	243-45372-00	243-45372-00	243-48689-00	243-48689-00
10 Heat Trap Insert (Inlet)	415-51556-00	415-51556-00	415-45167-00	415-45167-00
11 Cold Water Inlet Dip Tube (PEX)▲▲	415-51230-25	415-51230-25	---	---
Cold Water Inlet Dip Tube (Polysulfone)▲▲	---	---	415-45092-06	415-45092-06
12 Blower Harness	239-45617-02	239-45617-02	239-45617-02	239-45617-02
13 T&P Relief Valve	415-40594-02	415-40594-02	415-40594-02	415-40594-02
14 Right Side Inner Door Complete	239-48216-20	239-48216-20	239-48216-18	239-48216-18
15 Screw #10-12 x 3/4 HWH	239-52581-00	239-52581-00	239-52581-00	239-52581-00
16 Screw #8-18 x 3/4 HWH SLOT	239-44195-00	239-44195-00	239-44195-00	239-44195-00
17 Screw #8 X 3/4 HEX HD	239-81253-00	239-81253-00	239-81253-00	239-81253-00
18 Brass Drain Valve	415-42351-02	415-42351-02	415-42351-02	415-42351-02
19 Outer Door	239-46209-00	239-46209-00	239-46209-00	239-46209-00
20 Gas Valve Direct Replacement (Natural Gas)	239-49823-01	239-49823-01	239-49823-02	239-49823-02
21 Flammable Vapor Sensor Harness	239-50066-00	239-50066-00	239-50066-00	239-50066-00
22 2" Exhaust Adaptor w/Vent Terminal	239-46263-00	239-46263-00	239-46263-00	239-46263-00
23 Condensate Hose Kit (Optional)	415-45875-00	415-45875-00	415-45875-00	415-45875-00
24 Kit-Heat Trap Insert	239-51572-00	239-51572-00	265-45420-00	265-45420-00
25 ASSE Approved Mixing Valve (Optional)	239-51778-00	239-51778-00	239-51778-00	239-51778-00
26 Inner Door Gasket Kit (Ultra Low NOx)	239-51576-00	239-51576-00	239-51576-00	239-51576-00

* Applies to all warranties

Anode may need to be cut to length. See page 14.

▲ Order with item 7

▲▲ Order with item 10

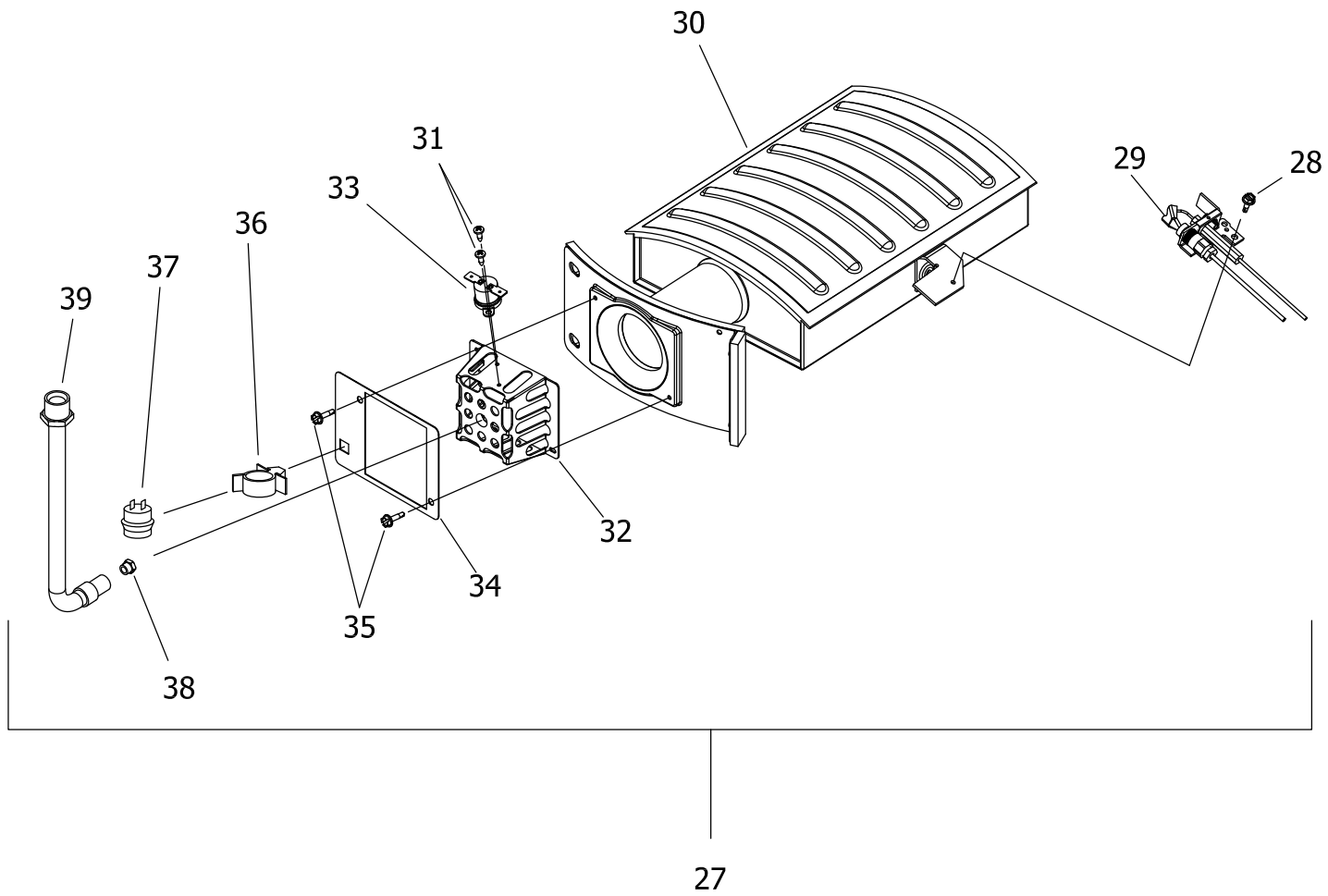

Item Description	Model	Model	Model	Model
	URG1PV40S*N	URG1PV50S*N	URG2PV40T*N	URG2PV50T*N
27 Natural Gas (N) Main Burner Assembly ***	265-48329-01-37	265-48329-02-37	265-48329-05-37	265-48329-01-37
28 Screw #8-18 x 1/2 HWH	239-32761-00	239-32761-00	239-32761-00	239-32761-00
29 Pilot Assembly**	265-48175-04	265-48175-04	265-48175-04	265-48175-04
Pilot Assembly w/ Inner Door Gasket Kit	265-51574-00	265-51574-00	265-51574-00	265-51574-00
30 Burner**	228-48383-18	228-48383-20	228-48383-16	228-48383-18
31 Screw #6-20 x 3/8 PHCR	239-43967-00	239-43967-00	239-43967-00	239-43967-00
32 Manifold Mount	239-46201-00	239-46201-00	239-46201-00	239-46201-00
33 Thermal Switch	415-43676-03	415-43676-03	415-43676-03	415-43676-03
34 FVIR Sensor Plate	239-48341-00	239-48341-00	239-48341-00	239-48341-00
35 Screw #8-18 x 3/4 HWH SLOT	239-44195-00	239-44195-00	239-44195-00	239-44195-00
36 Flammable Vapor Sensor Clip	239-45648-00	239-45648-00	239-45648-00	239-45648-00
37 Flammable Vapor Sensor	415-45560-00	415-45560-00	415-45560-00	415-45560-00
38 Nat. Gas (N) Main Burner Orifice 0 Ft. to 2,000 Ft. **	234-18194-37	234-18194-37	234-18194-37	234-18194-37
Nat. Gas (N) High Alt. Orifice 2,001 ft. to 7,000 Ft. (-475 model suffixes) **	234-18194-42	234-18194-42	234-18194-42	234-18194-42
Nat. Gas (N) High Alt. Orifice Kit 7,001 Ft. to 10,000 Ft.	265-51320-02-43	265-51320-02-43	265-51320-04-43	265-51320-04-43
39 Flexible Gas Feedline	233-46930-01	233-46930-01	233-46930-01	233-46930-01

* Applies to all warranties

** Inner door gasket kit recommended

*** Ordering a complete burner assembly may increase delivery time. Please order the specific component required for the quickest delivery.

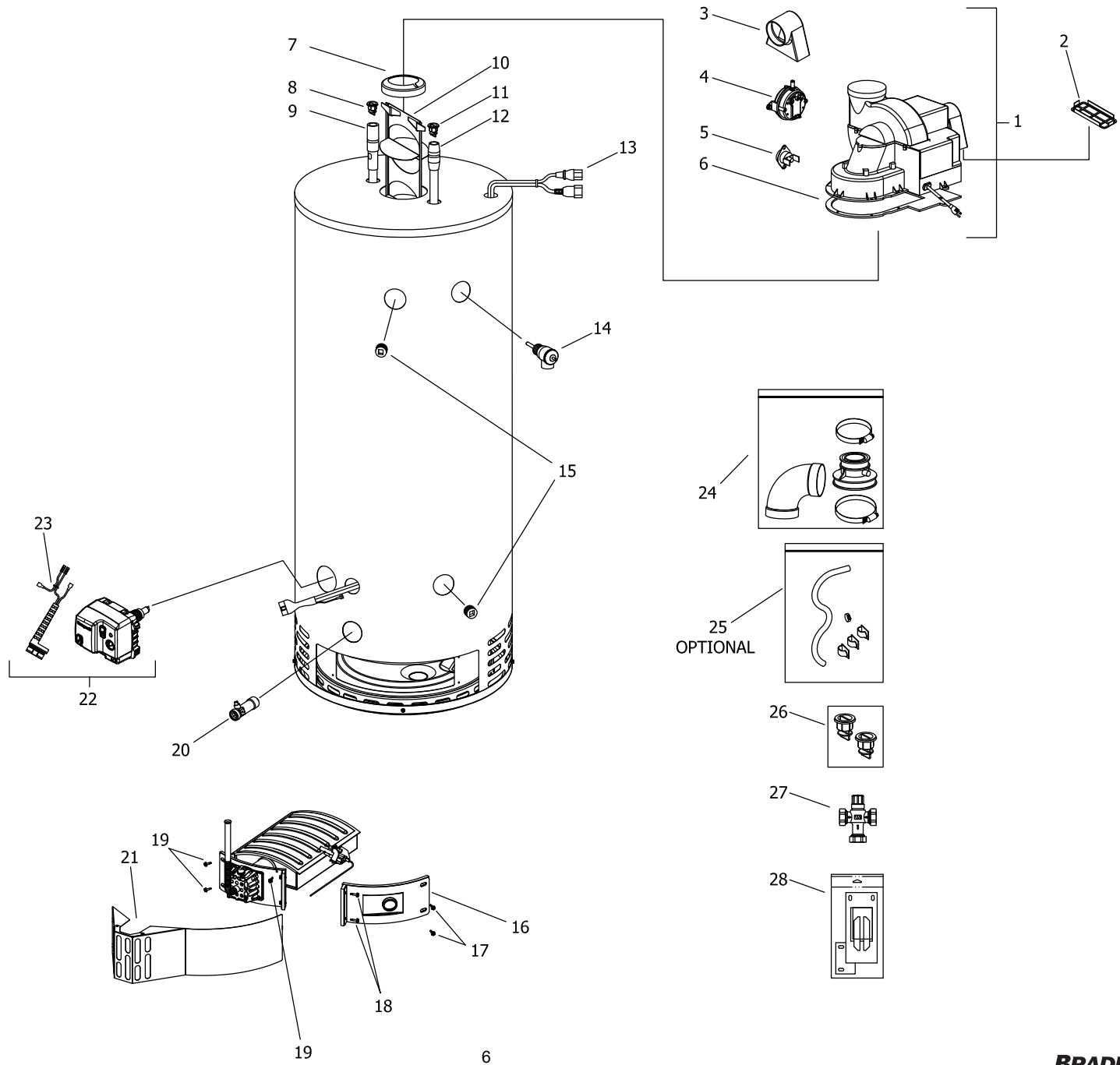

Item Description	Model	Model
	URG2PV50H*N	ULG2PV50H56*N
1 Blower Complete 0 Ft. to 2,000 Ft. (Normal Altitude)	265-48861-00	265-48861-00
Blower Complete 2,001 Ft. to 7,001 Ft. (High Altitude)	265-49227-00	265-49227-00
2 Dilution Air Clip	239-48176-00	239-48176-00
3 Air Mixing Inlet	239-45868-00	239-45868-00
4 Pressure Switch 0 Ft. to 2,000 Ft. (Normal Altitude)	415-47815-01	415-47815-01
Pressure Switch 2,001 Ft. to 7,000 Ft. (High Altitude)	415-45867-02	415-45867-02
5 Blower Temperature Switch	415-48752-00	415-48752-00
6 Blower Gasket	239-45866-00	239-45866-00
7 Flue Reducer	239-48802-00	239-48802-00
8 Heat Trap Insert (Outlet)	415-45167-00	415-45167-00
9 Hot Water Outlet Anode (Magnesium)▲ #	415-55482-00	415-55482-00
Hot Water Outlet Anode (Aluminum)▲#	415-55484-00	415-55484-00
Hot Water Outlet Anode (A420 Aluminum)▲ #	415-55486-00	415-55486-00
10 Flue Baffle	239-45373-00	239-45373-00
11 Heat Trap Insert (Inlet)	415-51556-00	415-45167-00
12 Cold Water Inlet Dip Tube (PEX)▲▲	415-51230-20	---
Cold Water Inlet Dip Tube (Polysulfone)▲▲	---	229-45092-08
13 Blower Harness	239-45617-02	239-45617-02
14 T&P Relief Valve	415-40594-02	415-40594-02
15 3/4" NPT Pipe Plug	239-11638-00	239-11638-00
16 Right Side Inner Door Complete	239-48216-18	239-48216-18
17 Screw-#10-12 x 3/4 HWH	239-52581-00	239-52581-00
18 Screw #8-18 x 3/4 HWH SLOT	239-44195-00	239-44195-00
19 Screw #8 X 3/4 HEX HD	239-81253-00	239-81253-00
20 Brass Drain Valve	415-42351-02	415-42351-02
21 Outer Door	239-46209-00	239-46209-00
22 Gas Valve Natural Gas	239-49823-02	239-49823-04
23 Flammable Vapor Sensor Harness	239-50066-00	239-50066-00
24 3" Exhaust Adaptor w/Vent Terminal	239-46264-00	239-46264-00
25 Condensate Hose Kit (Optional)	415-45875-00	415-45875-00
26 Kit-Heat Trap Insert	265-51572-00	265-45420-00
27 ASSE Approved Mixing Valve (Optional)	239-51778-00	239-51778-00
28 Kit-Inner Door Gasket (Ultra Low NOx)	239-51576-00	239-51576-00

* Applies to all warranties

Anode may need to be cut to length. See page 14.

▲ Order with item 8

▲▲ Order with item 11

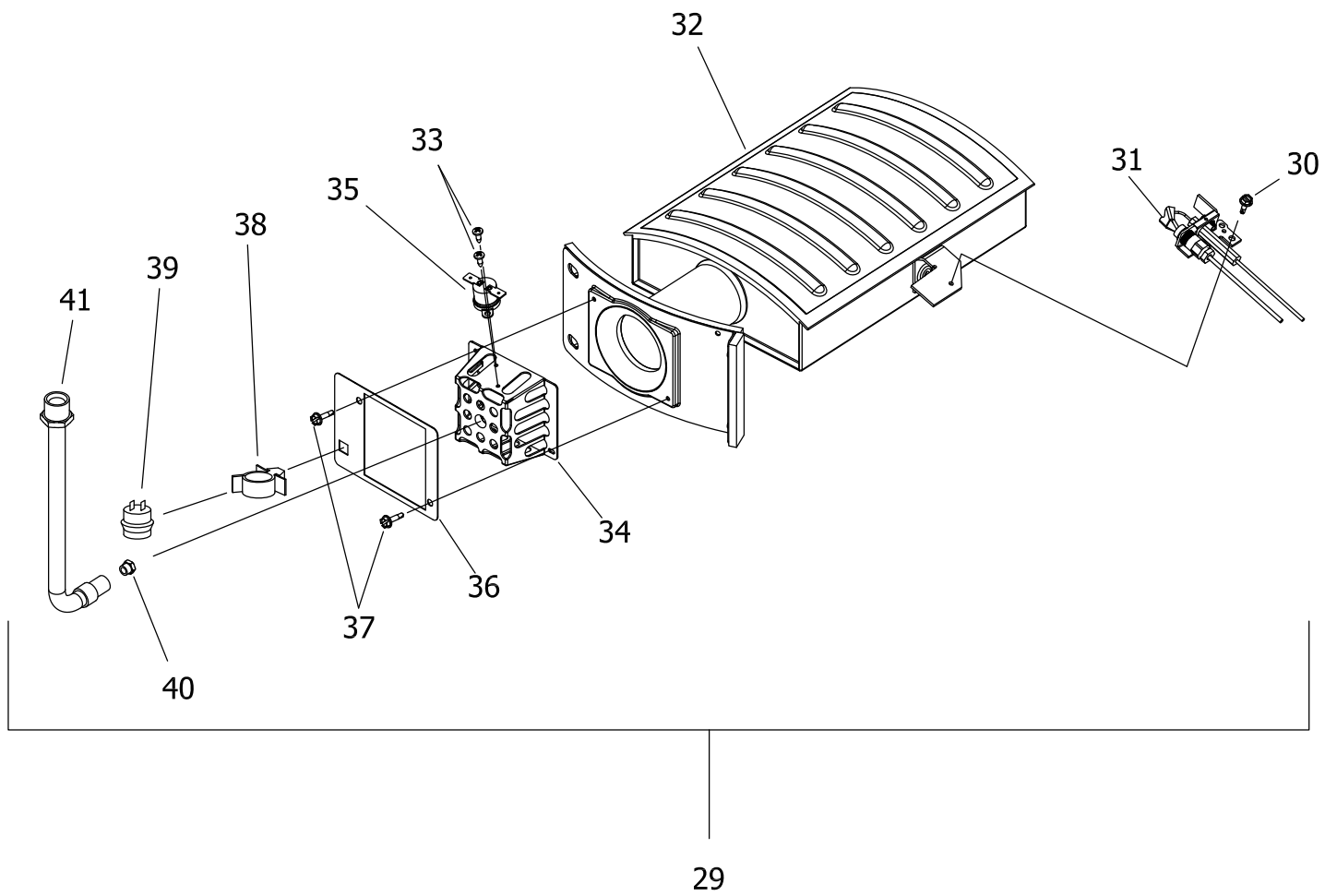

Item Description	Model	Model
	URG2PV50H*N	ULG2PV50H56*N
29 Burner Assembly***	265-48329-03-32	265-48329-03-32
30 Screw #8-18 x 1/2 HWH	239-32761-00	239-32761-00
31 Pilot Assembly**	233-48175-04	233-48175-04
Pilot Assembly w/ Inner Door Gasket Kit	265-51574-00	265-51574-00
32 Burner**	228-48383-19	228-48383-19
33 Screw #6-20 x 3/8 PHCR	239-43967-00	239-43967-00
34 Manifold Mount	239-46201-00	239-46201-00
35 Thermal Switch	415-43676-03	415-43676-03
36 FVIR Sensor Plate	239-48341-00	239-48341-00
37 Screw #8-18 x 3/4 HWH	239-44195-00	239-44195-00
38 Flammable Vapor Sensor Clip	239-45648-00	239-45648-00
39 Flammable Vapor Sensor	415-45560-00	415-45560-00
40 Nat. Gas (N) Main Burner Orifice 0 Ft. to 2,000 Ft. **	234-18194-32	234-18194-32
Nat. Gas (N) High Alt. Orifice 2,001 ft. to 7,000 Ft. (-475 model suffixes) **	234-18194-36	234-18194-36
Nat. Gas (N) High Alt. Orifice Kit 7,001 Ft. to 10,000 Ft.	265-51320-02-40	265-51320-02-40
41 Flexible Gas Feedline	233-46930-01	233-46930-01

* Applies to all warranties

** Inner door gasket kit recommended

*** Ordering a complete burner assembly may increase delivery time. Please order the specific component required for the quickest delivery.

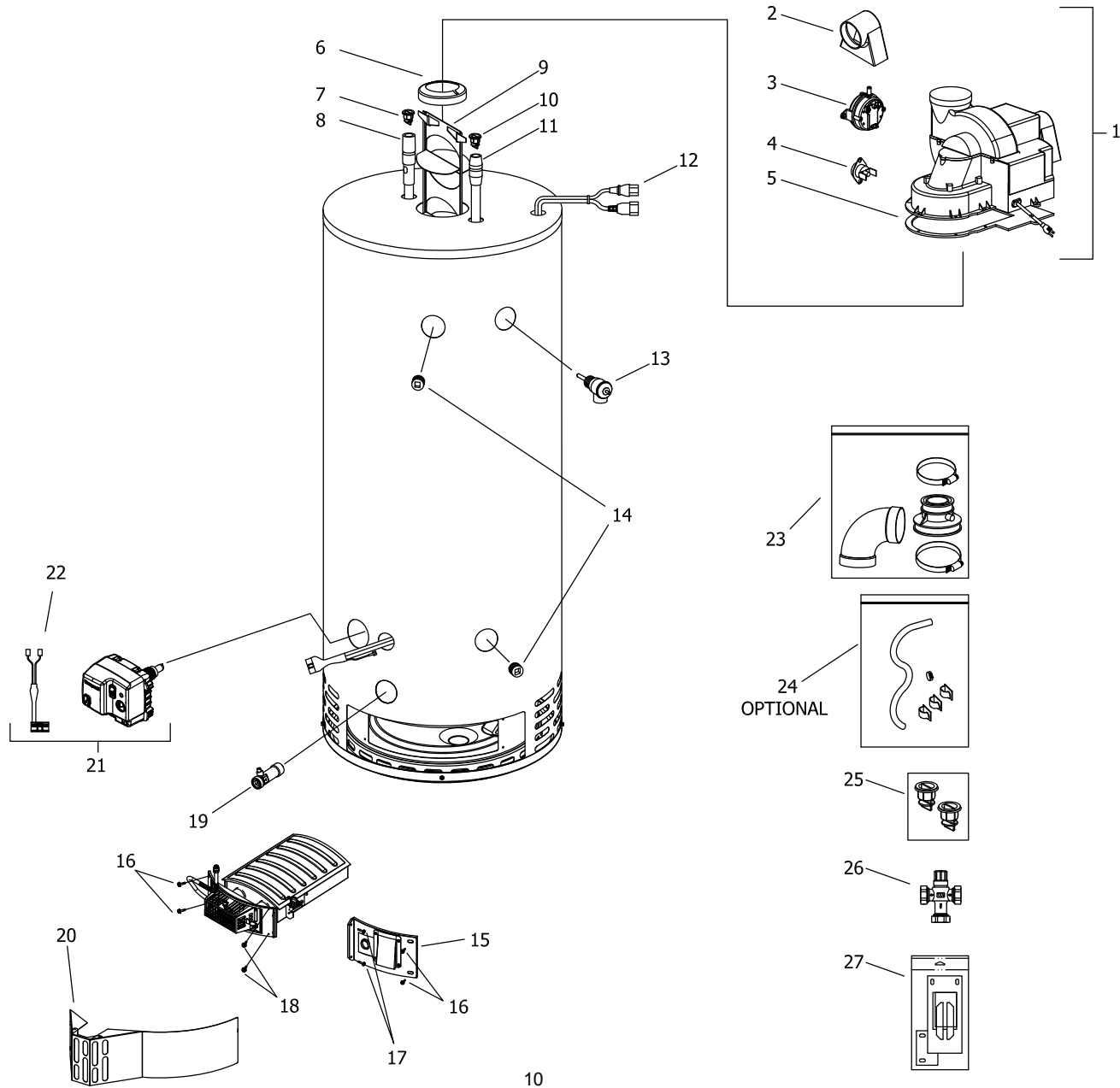

Item Description	Model	Model
	URG2PV75H*N	ULG2PV75H76*N
1 Blower Complete 0 Ft. to 2,000 Ft. (Normal Altitude)	415-45583-00	415-45583-00
Blower Complete 2,001 Ft. to 7,000 Ft. (High Altitude)	239-45986-00	239-45986-00
2 Air Mixing Inlet	239-45868-00	239-45868-00
3 Pressure Switch 0 Ft. to 2,000 Ft. (Normal Altitude)	239-45867-02	239-45867-02
Pressure Switch 2,001 Ft. to 7,000 Ft. (High Altitude)	239-45867-04	239-45867-04
4 Blower Temperature Switch	415-48752-00	415-48752-00
5 Blower Gasket	239-45866-00	239-45866-00
6 Flue Reducer	243-42572-00	243-42572-00
7 Heat Trap Insert (Outlet)	415-45167-00	415-45167-00
8 Hot Water Outlet Anode (Magnesium)▲ #	415-55482-00	415-55482-00
Hot Water Outlet Anode (Aluminum)▲#	415-55484-00	415-55484-00
Hot Water Outlet Anode (A420 Aluminum)▲ #	415-55486-00	415-55486-00
9 Flue Baffle	239-45373-00	239-45373-00
10 Heat Trap Insert (Inlet)	415-51556-00	415-51556-00
11 Cold Water Inlet Dip Tube (PEX)▲▲	415-51230-20	415-51230-29
12 Blower Harness	239-45617-02	239-45617-02
13 T&P Relief Valve	415-40594-02	415-40594-02
14 3/4" NPT Pipe Plug	239-11638-00	239-11638-00
15 Right Side Inner Door Complete	239-49804-22	239-49804-22
16 Screw-#10-12 x 3/4 HWH	239-52581-00	239-52581-00
17 Screw #8-18 x 3/4 HWH SLOT	239-44195-00	239-44195-00
18 Screw #8 X 3/4 HEX HD	239-81253-00	239-81253-00
19 Brass Drain Valve	415-42351-02	415-42351-02
20 Outer Door	239-49092-00	239-49092-00
21 Gas Valve Natural Gas	239-49823-02	239-49823-04
22 Simulated Resistive Device Harness with Leads	239-50408-00	239-50408-00
23 3" Exhaust Adaptor w/Vent Terminal	239-46264-00	239-46264-00
24 Condensate Hose Kit (Optional)	415-45875-00	415-45875-00
25 Kit-Heat Trap Insert	265-51572-00	265-51572-00
26 ASSE Approved Mixing Valve (Optional)	239-51778-00	239-51778-00
27 Kit-Inner Door Gasket (Ultra Low NOx)	239-49987-00	239-49987-00

* Applies to all warranties

Anode may need to be cut to length. See page 14.

▲ Order with item 7

▲▲ Order with item 10

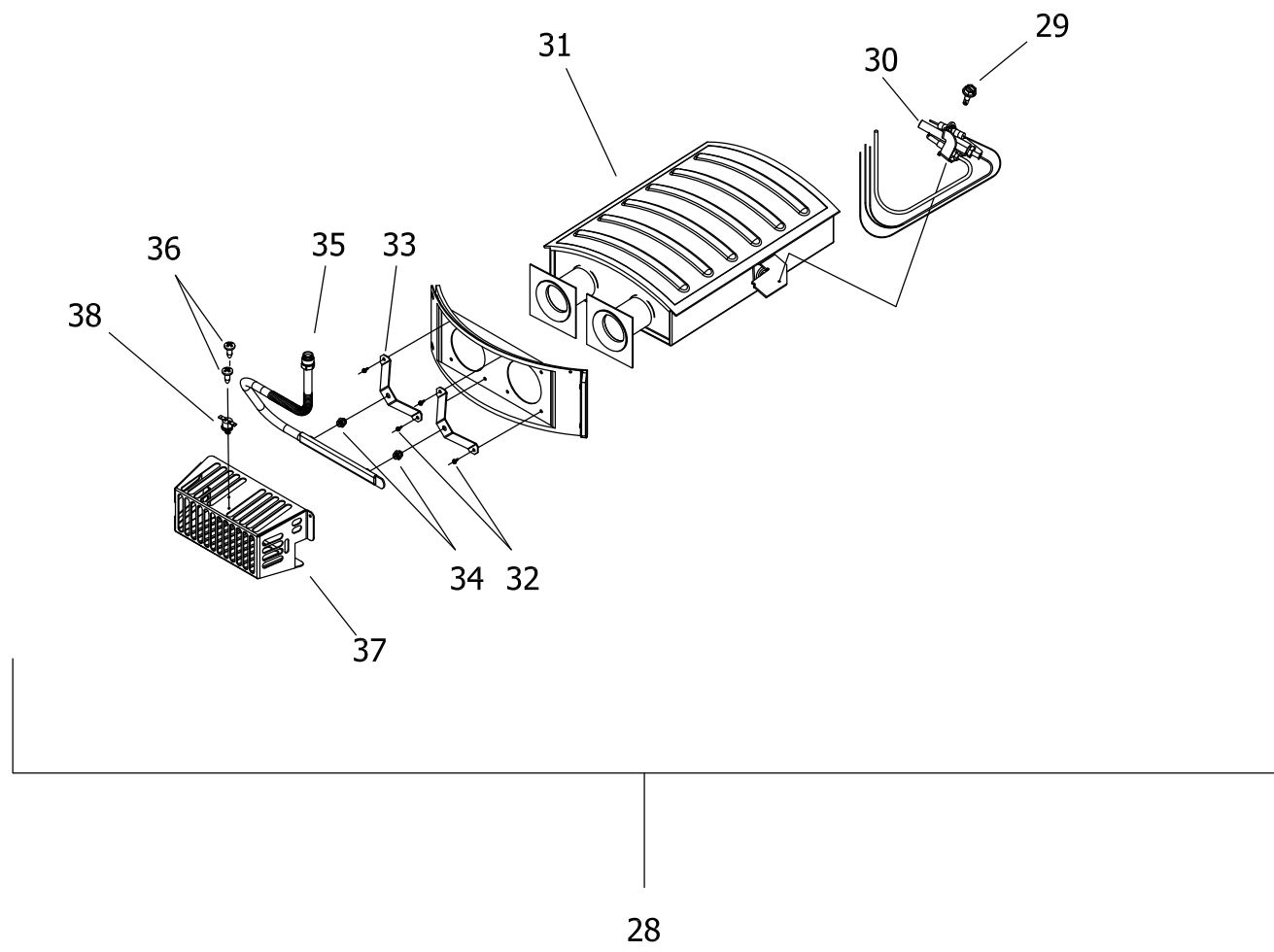

Item Description	Model	Model
	URG2PV75H*N	ULG2PV75H76*N
28 Burner Assembly***	265-49930-01-37	265-49930-01-37
29 Screw #8-18 x 1/2 HWH	239-32761-00	239-32761-00
30 Pilot Assembly**	233-50195-01	233-50195-01
31 Burner**	228-50194-01	228-50194-01
32 Screw #8-18 x 3/4 HWH	239-44195-00	239-44195-00
33 Orifice Bracket	239-49090-00	239-49090-00
34 Nat. Gas (N) Main Burner Orifice 0 Ft. to 2,000 Ft. **	234-41034-37	234-41034-37
Nat. Gas (N) High Alt. Orifice 2,001 ft. to 7,000 Ft. (-475 model suffixes) **	234-41034-42	234-41034-42
Nat. Gas (N) High Alt. Orifice Kit 7,001 Ft. to 10,000 Ft.	265-51315-03-43	265-51315-03-43
35 Flexible Gas Feedline	233-49091-00	233-49091-00
36 Screw #8-18 x 3/4 HWH	239-43967-00	239-43967-00
37 Manifold Cover	239-49832-00	239-49832-00
38 Thermal Switch	415-43676-03	415-43676-03

* Applies to all warranties

** Inner door gasket kit recommended

*** Ordering a complete burner assembly may increase delivery time. Please order the specific component required for the quickest delivery.



United States

Sales 1-800-523-2931
Technical Support 1-800-334-3393
Email techsupport@bradfordwhite.com
Warranty 1-800-531-2111
Email warranty@bradfordwhite.com
Service Parts 1-800-538-2020
Email parts@bradfordwhite.com

Canada

Sales 1-866-690-0961 1-905-203-0600
Fax 905-636-0666
Warranty 1-800-531-2111
Email warranty@bradfordwhite.com
Technical Support 1-800-334-3393
Email techsupport@bradfordwhite.com
Service Parts and Orders ca.orders@bradfordwhite.com

For U.S. and Canada field service, contact your professional installer or local Bradford White sales representative.

International

General Contact international@bradfordwhite.com