

OPERATOR'S MANUAL
TECHNICAL SUPPORT
ELECTRICAL SUPPLEMENT
PARTS AND ELECTRICAL
PARTS DIAGRAMS
MECHANICAL DIAGRAMS
TECHNIQUE

2022



Type B

Cake Donut Depositor

ITEM NUMBER **B00010001, 0226CHS**

SERIAL NUMBER

*Item Number and Serial Number are listed on a data tag attached to the equipment.
This manual should only be used with the Item Number(s) shown above.*



DECLARATION
OF CONFORMITY
INSIDE

SUPPORT

USA/Canada 1-800-BELSHAW
International (+1) 206-322-5474

Email service@belshaw.com
Web www.belshaw.com



Belshaw[®]

Donut Cutter Type B Operator's Manual

Belshaw Adamatic Bakery Group
814 44th Street NW, Suite 103
Auburn, WA 98001 USA
Phone: (206) 322-5474 • Fax: (206) 322-5425
Email: service@belshaw.com • www.belshaw.com

EQUIPMENT RECORD

Please provide the information below when you correspond with Belshaw about your machine.

Purchased by _____

Installed by _____

Date of Installation _____

Model number _____

Serial number _____

IN CASE OF DAMAGE TO EQUIPMENT

In case of damage to the equipment upon delivery, follow these steps immediately.

1. Inform the freight carrier. The phone number will be on the shipping receipt or label.
2. Take photographs of the equipment, both inside and outside the box or crate.
3. Do not throw away any packaging.
4. Report the damage to the distributor (or other party) from whom you bought the equipment.
5. Email your photos to the distributor (or other party) AND to Belshaw Customer Service at service@belshaw.com. Include a Belshaw Order Number in your communications. Your Order Number will begin with "CO...", followed by 6 digits) and should be marked on the box or crate.

IN CASE OF MISSING ITEMS

1. If possible, note the missing items on the delivery receipt of the freight carrier.
2. Take photographs of the entire shipment.
3. Follow steps 2 – 5 above.

020220

Belshaw Adamatic Bakery Group

814 44th Street NW, Suite 103, Auburn, WA 98001 USA

Phone: (+1)206-322-5474 • 800-578-2547 • 1-800-BELSHAW

E-mail: service@belshaw.com • www.belshaw.com

Contents

<u>1</u>	<u>Description</u>	<u>4</u>
<u>2</u>	<u>Operation</u>	<u>5</u>
<u>3</u>	<u>Cleaning</u>	<u>6</u>
<u>4</u>	<u>Maintenance</u>	<u>7</u>
	Lubrication	7
	Care, maintenance, and cleaning instructions for plungers, cylinders, and hoppers	7
<u>5</u>	<u>Donut-Making Helps</u>	<u>9</u>
	Tips on Making Quality Cake Donuts	9
	Calculating Correct Water Temperature	10
	Ratios of Plunger Sizes to Donut Weights	10
	Temperature Conversion	10

1

Description

The Type B Donut Cutter is designed to cut cake donut products and deposit them in a variety of fryers. It is designed to be mounted on a wall or on a column attached to the fryer.

During production, the operator must move the Cutter, holding the guide handle, to deposit donuts in the desired locations in the fryer. The operator must work safely at all times and read this manual and follow its instructions and warnings.

A thorough understanding of how to install, maintain, and safely operate the Type B Donut Cutter will prevent production delays and injuries. Heed the following warnings and all other warnings that appear in this manual:

- Make sure the machine is mounted securely. Doing so will prevent the machine from tipping over or falling, which could cause serious injury.
- When the machine is column-mounted on a fryer, make sure the fryer is securely fastened to the floor. If the fryer is not fastened to the floor, the weight of the cutter could cause the fryer to tip over, resulting in serious burns, other injury, or death.
- To avoid damaging the machine, never use force to assemble, disassemble, operate, clean, or maintain it.
- Be careful never to get shortening, water, or other materials on the floor. If anything does get spilled on the floor, clean the area immediately. Materials on the floor can cause people to slip or fall, resulting in serious injury or loss of life.

WARNING

Never put your hand in the hopper or between trip arms while machine is being operated.

DANGER!

When the cutter is column mounted, the fryer must be securely fastened to the floor to prevent tipping or overturning the fryer. If the fryer is tipped, SERIOUS BURNS or other injury can occur.

For best results, and to keep your machine in perfect running condition, observe the following:

- Be sure that wing nuts and thumb nuts are kept tight when the cutter is running.
- Rotate the crank before filling the hopper with dough to be sure that it turns freely.
- The numbered scale on the side of the cutter head regulates the weight of the donuts. To change, loosen the wing nut and set pointer at desired number (larger numbers product larger donuts). Retighten the wing nut.
- The outer lip of the cutting cylinder should clear the shortening in the fryer by the following distances:

Cake plungers, sizes 7/8" to 1" require 1" clearance.

Cake plungers, 1 1/8" through 2 1/4" require 1 1/4" to 1 3/8" clearance.

French Cruller plunger, all sizes, require 1 1/2" clearance.

This height is adjusted with the set collar on the column or wall mount bushing.

- After putting dough into an empty hopper, any air trapped in the cylinder should be expelled. To do this, hold the dough bowl under the cutter, and turn the donut cutter crank until it has dropped two or three donuts into the bowl (this

dough can then be replaced in the hopper). After this initial priming, dough can be added without repriming as long as the hopper hasn't been emptied.

- When ready to start frying, swing the cutter over the frying kettle and turn the crank to start depositing donuts. Move the cutter approximately 4" after each donut is dropped. Swing the cutter back from over the fryer when done cutting donuts.
- To use the last of the dough in the hopper, push the remaining dough to the bottom of the hopper. Use a rubber scraper (spatula) to avoid scratching hopper.
- Once a week, remove the main frame from the pivot arm and hold in horizontal position (with trip arms facing down), and allow any accumulated oil to run from the cam case. Wipe any excess oil from trip arms and cam case.

WARNING

Never put your hand in the hopper or between trip arms while cutter is being cranked.

3

Cleaning

The hopper and plunger are easily removed for cleaning purposes. Remove the hopper and plunger as follows:

1. Be sure the plunger is in the “stop” position so the lower piston is up in the hopper cylinder.

WARNING

Keep your hand under the cylinder flange at the bottom of the hopper to keep the plunger from falling through.

2. Loosen wing nut at crown bearing and remove crown bearing.
3. Loosen wing nut at lower clamp hinge.
4. Open hinge and pull hopper and plunger forward. The cylinder can be removed from the hopper. If they do not separate readily, run hot water on the hopper and cold water on the cylinder and try again.

CAUTION

Never put your hand in the hopper or between trip arms while cutter is being cranked.

Lubrication

CUTTER SHAFT: One drop of light food grade oil to the main shaft bearing, located on the hub between the dial and cam case, once a day.

CAMS AND TRIP ARM BEARINGS: Before starting and after every two hours of operation, apply several drops of light food grade oil to each of the two holes in the top of the cam case.

CAM TRACK: Once a week, grease cam tracks with food grade grease. Turn cutter manually to spread trip arms. Using a ½” wide paint brush, apply grease to cam track through opening between trip arms.

CROWN BEARING: Before starting and after every two hours of operation, apply several drops of edible grade mineral oil onto the center rod directly above the crown bearing.

PLUNGERS & CYLINDERS: The plungers and cylinders of your donut cutter are precision equipment built from stainless steel. They will provide years of productive service if they are handled carefully. Plungers and cylinders should be covered with a thin film of cooking oil. This provides protection and lubrication for the plungers and cylinders.

Care, maintenance, and cleaning instructions for plungers, cylinders, and hoppers

The plungers, cylinders and hoppers of your donut machine are precision instruments built from alloy steels and aluminum. They should be handled with care to insure continued satisfactory performance.

When cleaning aluminum, selection of the right type cleaner is your most important consideration. Any household dish washing detergent that is safe for aluminum does a good job of cleaning and does not attack aluminum. Strong Alkali cleaners, such as lye, soda ash, and tri-sodium phosphate, will discolor or even corrode aluminum even in weak solutions.

WARNING TO PREVENT INJURY, DISCONNECT MACHINE FROM POWER SOURCE BEFORE REMOVING OR INSTALLING PLUNGERS, CYLINDERS, OR HOPPER.

DO NOT Handle roughly or drop on hard surfaces.

DO NOT Mix with other utensils in the sink when washing.

DO NOT Allow to rust. Always wash parts thoroughly. Dry completely and then lubricate with mineral oil or liquid shortening before storing or reinstalling in unit.

DO NOT Force the machine if it becomes jammed. Disassemble and remove any obstruction to prevent damage to the plunger.

Washing Plungers, Cylinders, and Hoppers

By Hand:

Remove “O” Rings, if so equipped.

Use plenty of warm water.

Add cleaner approved for aluminum in concentrations recommended by manufacturer.

Presoak to loosen stubborn or dried-on deposits.

Use a non-scratching plastic scour cloth to remove soil and restore luster.

Rinse in clear hot water (170-190 °F)

Wipe completely dry.

Dip plungers in mineral oil or liquid shortening to prevent rust and sticking.

By Machine:

Remove “O” rings, if so equipped. Clean, hot water must be used with a minimum temperature of 160°F (71°C) for single tank conveyor machines. For all other machines, a temperature of 140°-160°F (60°-71°C) must be used.

Use clean, hot water (170°-190°F; 77°-88°C) during rinsing cycle. Avoid contamination of the rinsing water with the detergent.

Dry completely. Dip plungers and cylinders in mineral oil or liquid shortening to prevent rust and sticking.

**CAUTION! NEVER IMMERSE
MAIN CUTTER FRAME
ASSEMBLIES, CAMS,
BEARINGS, ROLLERS OR
ELECTRICAL COMPONENTS IN
WATER.**

Special Instructions for The Care of French Plungers:

The French plunger must be handled with great care. Before each use, put one drop of mineral oil on each of the gibs that slide in the grooves near the top of the plunger. After each use, unscrew the lower piston and remove the product former. Thoroughly wash and dry and then oil the parts with mineral oil or liquid shortening to prevent sticking. Reassemble the plunger. Be certain that the bottom piston is threaded into place completely.



5

Donut-Making Helps

Tips on Making Quality Cake Donuts

- Use the correct batter temperature.
In general, the correct batter temperature is 75°-80°F/24°-27°C. Check the mix manufacturer's instructions, as the recommended temperature range may vary.
If the batter is too warm, the donuts will lack volume and may "ring out" or be misshapen. If the batter is too cold, the donuts will stay under the shortening too long, fry too slowly, and crack open or ball up. They may also absorb excess shortening and lose volume.
- Use the correct floor time.
A floor time of 10 minutes between mixing and cutting allows the baking powder to react with the water. This helps the donuts attain the proper volume the proper level of shortening penetration.
If the floor time exceeds 30 minutes, the mix will gas off, the donuts will lose volume and shape and will absorb too much shortening.
- Use the correct frying temperature.
The correct shortening temperature for frying is 370°-380°F/188°-193°C.
If the shortening is too hot, the donuts will fry too quickly on the outside and will lose volume. The donuts may also become dense inside.

If the shortening is too cold, the donuts will spread too rapidly, will form large rings, will tend to crack open, will be too light in appearance, and will absorb too much shortening.

- Maintain the proper shortening level. We recommend a distance of 1 1/4" between the cutter and the shortening.

If the shortening is too deep, the donuts may not turn over when they reach the turner, causing them to cook unevenly.

If the shortening is too shallow (too far below the cutter), the donuts may not drop flat, may turn over while submerging and surfacing, and may become irregular, cracked, or rough-cruled.

- Ensure that the donuts absorb the right amount of shortening.

Donuts should absorb 1-1/2 to 3 oz/42 to 85 g of shortening per dozen, depending on their weight. You can achieve proper absorption by following tips 1-3.

- If the donuts do not absorb enough shortening, they will not keep well.

If they absorb too much shortening, they will lose volume and may become misshapen. If this happens, follow tips 1-3, mix the batter a little longer than usual, turn the donuts as soon as they become golden brown, and turn the donuts only once.

Calculating Correct Water Temperature

The following is an example of how to calculate the correct water temperature to use. You must use your own room temperature, dry mix temperature, desired batter temperature, and, if you are making yeast-raised donuts, estimated temperature increase during mixing.

	Cake Donuts		Yeast-Raised Donuts	
	°F	°C	°F	°C
Room temperature	72	22.2	72	22.2
Dry mix temperature	+70	+21.1	+70	+21.1
Total A	142	43.3	142	43.3
Desired batter temperature	75	23.9	80	26.7
	<u>x3</u>	<u>x3</u>	<u>x3</u>	<u>x3</u>
Total B	225	71.7	240	80.1
Total B	225	71.7	240	80.1
-Total A	<u>-142</u>	<u>-43.3</u>	<u>-142</u>	<u>-43.3</u>
Desired water temp. for cake donuts	83°F	28.4°C	98	36.8
			↓	↓
			98	36.8
			<u>-30</u>	<u>-17</u>
Temperature increase during mixing (average: 30°F/17°C)				
Desired water temperature for yeast-raised donuts	68°F		68°F	19.8°C

Ratios of Plunger Sizes to Donut Weights

The weights given are for donuts without icings or other toppings. They are provided for reference only, as weights vary according to the density of the batter.

Plunger Size	Donut Weight per Dozen
1"	5-8 oz/142-227 g
1 5/8"	14-17 oz/397-482 g
1 3/4"	16-20 oz/454-567 g
1 7/8"	19-24 oz/539-680 g
2"	22-27 oz/624-765 g

Temperature Conversion

To convert temperatures from Fahrenheit to Celsius, subtract 32 from °F and divide the result by 1.8. For example, $212^{\circ}\text{F} - 32 / 1.8 = 100^{\circ}\text{C}$.

To convert temperatures from Celsius to Fahrenheit, multiply °C by 1.8 and add 32 to the result. For example, $(100^{\circ}\text{C} \times 1.8) + 32 = 212^{\circ}\text{F}$.

°F	°C	°F	°C
55	12.8	340	171.1
60	15.6	345	173.9
65	18.3	350	176.7
70	21.2	355	179.4
75	23.9	360	182.2
80	26.7	365	185.0
325	162.8	370	187.8
330	165.6	375	190.6
335	168.3	380	193.3



Belshaw[®]

Donut Cutter Type B

Technical Supplement

Belshaw Adamatic Bakery Group

814 44th Street NW, Suite 103

Auburn, WA 98001 USA

Phone: (206) 322-5474 • Fax: (206) 322-5425

Email: service@belshaw.com • www.belshaw.com

Contents

<u>Contents</u>	3
<u>1 Description</u>	5
<u>2 Installation</u>	6
Wall Mount	6
Column Mount	7
A: Column Mounting on Belshaw Electric Fryer	7
B: Column Mounting on Belshaw Gas Fryer	7
C: Column Mounting on non-Belshaw Fryer without Adapter Kit	8
<u>3 Maintenance</u>	9
Lubrication	9
<u>4 Troubleshooting</u>	10
FACTORY PARTS AND REPAIR SERVICE	10
<u>5 Plunger, Mounting Info</u>	16
#0400 HEIGHT ADJUSTMENT KIT	18
INSTALLATION INSTRUCTIONS	18
<u>6 Parts Info</u>	20

1

Description

The Type B Donut Cutter is designed to cut cake donut products and deposit them in a variety of fryers. It is designed to be mounted on a wall or on a column attached to the fryer.

During production, the operator must move the Cutter, holding the guide handle, to deposit donuts in the desired locations in the fryer. The operator must work safely at all times and read this manual and follow its instructions and warnings.

A thorough understanding of how to install, maintain, and safely operate the Type B Donut Cutter will prevent production delays and injuries. Heed the following warnings and all other warnings that appear in this manual:

- Make sure the machine is mounted securely. Doing so will prevent the machine from tipping over or falling, which could cause serious injury.
- When the machine is column-mounted on a fryer, make sure the fryer is securely fastened to the floor. If the fryer is not fastened to the floor, the weight of the cutter could cause the fryer to tip over, resulting in serious burns, other injury, or death.
- To avoid damaging the machine, never use force to assemble, disassemble, operate, clean, or maintain it.
- Be careful never to get shortening, water, or other materials on the floor. If anything does get spilled on the floor, clean the area immediately. Materials on the floor can cause people to slip or fall, resulting in serious injury or loss of life.

WARNING

Never put your hand in the hopper or between trip arms while machine is being operated.

DANGER!

When the cutter is column mounted, the fryer must be securely fastened to the floor to prevent tipping or overturning the fryer. If the fryer is tipped, SERIOUS BURNS or other injury can occur.

Wall Mount

When the donut cutter is to be mounted on a wall bracket, it is mandatory to provide a good, solid support on the wall. For this purpose, we suggest using a 2" x 4" or 2" x 6" timber of good quality. The timber should extend from the ceiling to the floor. The timber must be secured with #4 wood screws, 4" long minimum, screwed directly into a wall stud. The screws should be located approximately every 12" over the entire length of the timber.

After attaching the 2" x 4" or 2" x 6" timber as described above, do the following:

1. Position the fryer 6" to 8" from the wall and slightly to the right or left of the timber support. Level the fryer.
2. Lay a straight edge (a board will do) across the kettle top to the wall support and mark the height of the kettle top on the wall support.
3. Find the point in the center of the wall support and 15" above the kettle height. Drill a 1/4" diameter hole at this point and attach the wall plate to the wall support with a 5/16" x 1 1/2" lag screw through the top hole in the wall plate.
4. Check to see that the wall plate is vertical (use a level if available). Then, secure the wall plate with the five remaining lag screws.
5. To connect the straight arm section to the wall plate: First slide the bushing through one leg of the straight arm, slide set collar onto the bushing (pin side down); then slide the bushing through the hole in the other leg of the straight arm. Position the bushing between the hinge

brackets on the wall plate and pass the wall pin through hinge brackets and bushing (See Figure 1).

6. The pivot arm is connected to the straight arm by passing the arm pin through both arm sections, with the legs of the pivot arm between the legs of the straight arm (See Figure 1).
7. The cutter frame can now be mounted on the pin at the end of the pivot arm.

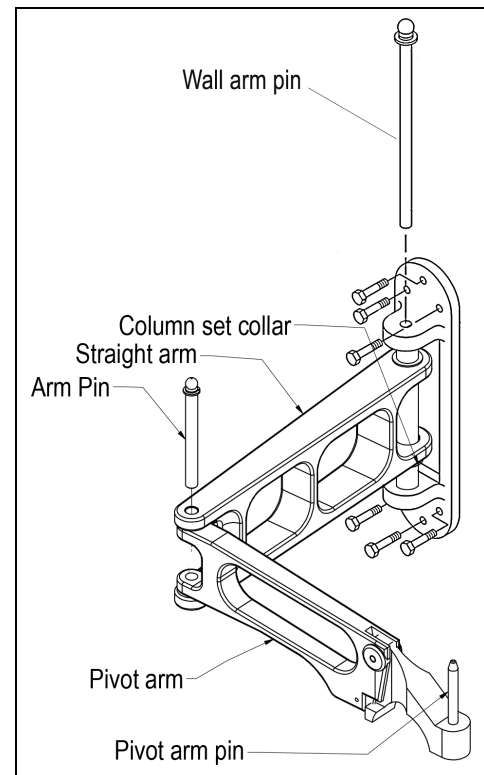

Figure 1

Column Mount

If you have a Belshaw fryer, see the following instructions “A” for electric fryers, or “B” for gas fryers. For a list of adapter kits for non-Belshaw fryers, check the information sheet in the Appendix of this manual. If no adapter kit is available for your fryer, see instructions “C”.

WARNING

When the cutter is column mounted, the fryer must be securely fastened to the floor to prevent tipping or overturning the fryer. If the fryer is tipped, serious burns or other injuries can occur.

A: Column Mounting on Belshaw Electric Fryer

1. Fasten the fryer to the floor.
2. Slide the column mounting brackets onto the column.
3. Remove six existing nuts and washers from the mounting blocks on the back of the fryer cabinet. **NOTE:** On older Belshaw fryers with narrow kettle flanges, there will be no mounting blocks, but the mounting holes will have been pre-punched in the sheet metal cabinet.
4. Mount the column and mounting brackets onto the fryer by placing the mounting brackets on respective bolts, and reinstalling the nuts and washers from Step 3. With the column resting on the floor, tighten the 5/16-18 X 1” square head set screws in the mounting brackets.
5. Slide the set collar onto the column.
6. Slide the straight arm section onto the column. Connect the pivot arm to the straight arm with the arm pin (See Figure 2).
7. The cutter frame can now be mounted on the pin at the end of the pivot arm.

IMPORTANT: An extension arm limiting bracket is designed to help keep the fryer from tipping if a column mounted cutter is inadvertently swung out away from the fryer. The extension limiting bracket is required for models 618, 618L and 624 fryers.

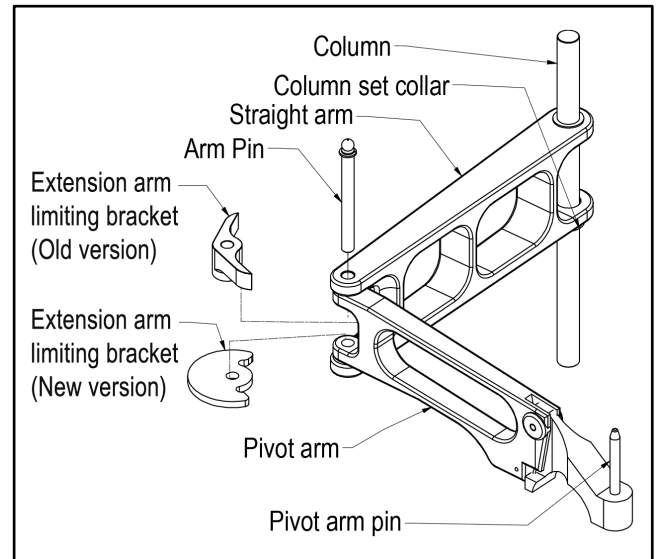

Figure 2

B: Column Mounting on Belshaw Gas Fryer

1. Fasten the fryer to the floor.
2. Slide the column mounting brackets onto the column.
3. Mount the column and mounting brackets onto the fryer and secure with 5/16-18 X 3/4” hex head bolts and lock washers.
4. Slide the set collar onto the column.
5. Slide the straight arm section onto the column. Connect the pivot arm to the straight arm with the arm pin (See Figure 2).
6. The cutter frame can now be mounted on the pin at the end of the pivot arm.

IMPORTANT: An extension arm limiting bracket is designed to help keep the fryer from tipping if a column mounted cutter is inadvertently swung out away from the fryer.

The extension limiting bracket is required for models 618, 618L and 624 fryers. Refer to the instruction sheet SB-91 in the Appendix.

C: Column Mounting on non-Belshaw Fryer without Adapter Kit

1. Fasten the fryer to the floor.
2. Slide the column mounting brackets onto the column.
3. Determine the column location by standing the column with mounting brackets against the fryer cabinet near the back corner of the fryer on the side the operator will stand. The mounting brackets can be fastened to either the back or the side of the cabinet, but be sure the location you choose will allow free movement of the swing arm,
4. After the location has been chose, use a level to make the column assembly as vertical as possible. For stability, locate the two column mounting brackets as far apart as possible.
5. Use the holes in the mounting brackets as guides for drilling 5/16” holes in the fryer cabinet. Secure the mounting brackets and assembled column to the fryer

cabinet with 5/16” bolts, flat washers, lock washers and nuts.

6. With the column resting on the floor, tighten square head set screws in the mounting brackets.
7. Slide the set collar onto the column.
8. Slide the straight arm section onto the column. Connect the pivot arm to the straight arm with the arm pin (See Figure 2).

IMPORTANT: A 618L-0104 extension limiting bracket is designed to help keep the fryer from tipping if a column mounted cutter is inadvertently swung out away from the fryer. The extension limiting bracket is required for models 618, 618L and 624 fryers. Refer to the instruction sheet SB-91 in the Appendix.

WARNING

When drilling holes through the fryer cabinet, be sure the drill does not damage the fryer internally.

9. The cutter frame can now be mounted on the pin at the end of the pivot arm.

Lubrication

CUTTER SHAFT: One drop of light food grade oil to the main shaft bearing, located on the hub between the dial and cam case, once a day.

CAMS AND TRIP ARM BEARINGS: Before starting and after every two hours of operation, apply several drops of light food grade oil to each of the two holes in the top of the cam case.

CAM TRACK: Once a week, grease cam tracks with food grade grease. Turn cutter manually to spread trip arms. Using a ½” wide paint brush, apply grease to cam track through opening between trip arms.

CROWN BEARING: Before starting and after every two hours of operation, apply several drops of edible grade mineral oil onto the center rod directly above the crown bearing.

PLUNGERS & CYLINDERS: The plungers and cylinders of your donut cutter are precision equipment built from stainless steel. They will provide years of productive service if they are handled carefully. Plungers and cylinders should be covered with a thin film of cooking oil. This provides protection and lubrication for the plungers and cylinders.

4

Troubleshooting

This section is designed as an aid in troubleshooting. It does not cover every possible problem that might arise, and it is not a substitute for a qualified technician.

To use the following chart: look in the first column to find the section dealing with the problem. In the middle column you will find one or most possible causes. The other column has possible solutions. To avoid unnecessary repairs, be sure to isolate the correct cause of the problem before taking corrective action.

machine can be shipped back, freight collect, within five days.

Ship to:
Belshaw Adamatic Bakery Group
814 44th Street NW, Suite 103
Auburn, WA 98001 USA
Phone: (206) 322-5474
Fax: (206) 322-5425

FACTORY PARTS AND REPAIR SERVICE

Replacement Part Orders (Include the following information with your order):

1. Model name and number of your machine.
2. Serial number of your machine
3. Voltage, phase, and hertz (if applicable).
4. Part number, part name, description, size (if applicable), etc.
5. Quantity desired

Factory Rebuild Service

If your machine becomes badly worn or seriously out of adjustment, we have a complete rebuild and repair service. Call the service department for a Return of Goods Authorization number (R.G.A. #). Return your machine to the factory (with the R.G.A. # on the outside of the box, and on the paperwork inside), FREIGHT PREPAID, with your instructions, phone number, and the name of the person to contact when a cost estimate has been determined. In most cases, the

DONUTS DO NOT DROP STRAIGHT OR SEPARATE FROM THE CYLINDER EVENLY	
Possible Causes	What To Do
Machine frame out of alignment.	Send to factory.
Dirty cylinder.	Clean as required.
Damaged cylinder liner lip.	Replace cylinder liner.
Cutter not level.	Adjust mounting system.
Worn plunger pistons.	Replace.
Worn cylinder liner.	Replace.
UNUSUAL NOISES (CLICKING OR BANGING)	
Possible Causes	What To Do
Machine frame out of alignment.	Send to factory.
Plunger bent.	Repair or replace.
Trip arm bent.	Adjust trip arm spacing. See SB-17 in Appendix.
Upper and lower pistons straddling cylinder.	Adjust trip arm spacing. See SB-17 in Appendix.
Dodge (drive) pin slipping.	Tighten brake bands.

VARIATION IN DONUT SIZE	
Possible Causes	What To Do
Worn or undersize plunger pistons.	Replace.
Hopper not tightly seated in cylinder assembly.	Tap down lightly. Use film of cake donut batter between hopper and cylinder assembly to help form a seal. To make a careful check of the seal: place hand over cylinder to prevent leaks, turn hopper upside down and push hopper into tank or tub of water until joint of hopper and cylinder are submerged. Leakage will show as bubbles.
Worn cams.	Replace.
Worn roller pin in trip arms.	Replace.
Worn cam rollers.	Replace.
Center rod lock pins on plunger sheared off.	Repair or replace.
RINGING OUT (DIAMETER OF DONUT AND DONUT HOLE BECOME TOO LARGE)	
Possible Causes	What To Do
Donut is turning after drop.	Set screen to allow only a shallow drop.
Lower piston has incorrect travel.	Adjust trip arm spacing. See SB-17 in Appendix.
Improper mixing.	Check mixing procedure.
Mix temperature too high.	Lower mix temperature to match manufacturer's specifications.

GOBBING (DEPOSIT OF UNWANTED DOUGH ON PRODUCT)	
Possible Causes	What To Do
Worn plunger or cylinder.	Replace.
Damaged cylinder lip.	Replace.
JAMMING	
Possible Causes	What To Do
Machine frame out of alignment.	Send to factory.
Plunger bent.	Repair or replace.
Trip arm bent.	Adjust trip arm spacing. See SB-17 in Appendix.
Obstruction in cylinder.	Clear obstruction.
FRENCH CRULLER PLUNGER – STICKING OR JAMMING	
Possible Causes	What To Do
Former assembly, 7B-1002, stuck or corroded to center rod, 7B-1004.	Unscrew lower piston 7B-0003. Former should slide off. If piston and/or former are stuck, soak them 24 hours in light food grade oil. Tap with soft hammer to loosen, and then disassemble for cleaning.
FRENCH CRULLER PLUNGER – BINDING IN CYLINDER	
Possible Causes	What To Do
Former bent out of alignment.	Replace former 7B-1002. Be sure to order correct size.
FRENCH CRULLER PLUNGER – PISTON WILL NOT ROTATE	
Possible Causes	What To Do
Gibs 7B-0013 sheared off.	Replace 7B-0013 gibs. (Order correct size: 7B-0013A gibs for sizes 1 1/8” and 1 1/4”; 7B-0013 for sizes 1 3/8 to 2”.)

FRENCH CRULLER PLUNGER – FORMER WILL NOT ROTATE	
Possible Causes	What To Do
Gibs inside piston on 7B-1003 or 7B-1006 side rod assembly are worn out or sheared off.	Replace 7B-1003 or 7B-1006 side rod assembly.
FRENCH CRULLER PLUNGER – DOUGH WILL NOT DROP OFF CLEANLY	
Possible Causes	What To Do
5a. Batter too stiff. 5b. Cylinder tip not clean. 5c. Cylinder tip damaged.	5a. Thin mix down with warm water or warm milk. 5b. Wash tip and oil lightly. 5c. Replace cylinder.
FRENCH CRULLER PLUNGER – FRENCH CRULLERS WILL NOT HOLD SHAPE	
Possible Causes	What To Do
6a. Improper temperature or improper mixing. 6b. Improper fry time and temperature.	6a. Check proper temperature and mixing time. 6b. Check for proper fry time and temperature.
FRENCH CRULLER PLUNGER – DONUTS COME OUT MISSING FLUTES	
Possible Causes	What To Do
7a. Former 7B-1002 flutes plugged. 7b. Trip arm bent.	7a. Disassembly plunger, clean former and reassemble. 7b. Adjust trip arm spacing. See SB-17 in Appendix.

BALL PLUNGER – BALLS STICK TOGETHER	
Possible Causes	What To Do
Machine set too high allowing balls to swing.	Set machine so end of plunger is just touching the shortening when the balls are extruded.
BALL PLUNGER – BALLS ARE NOT SAME SIZE	
Possible Causes	What To Do
One or more holes plugged with lump of dough.	Remove plunger and clean cup out.
STICK PLUNGER – STICKS BEND AND ARE POORLY SHAPED	
Possible Causes	What To Do
Trying to cut too long a stick.	1a. Shorten up by setting dial adjustment to smaller size. 4-5” would be maximum controllable length. 1b. Set machine height so extrusion takes place just at the surface of the shortening.
KRINKLE PLUNGER – LOWER PISTON AND FORMER WILL NOT COME OFF	
Possible Causes	What To Do
Piston and former stuck and/or corroded to center rod.	Soak in light food grade oil for 24 hours. Tap lightly with a soft hammer to loosen.
KRINKLE PLUNGER – IRREGULAR PRODUCT	
Possible Causes	What To Do
Former flutes plugged.	Disassemble and clean. Reassemble.

5

Plunger, Mounting Info

FRENCH PLUNGER

CARE & MAINTENANCE

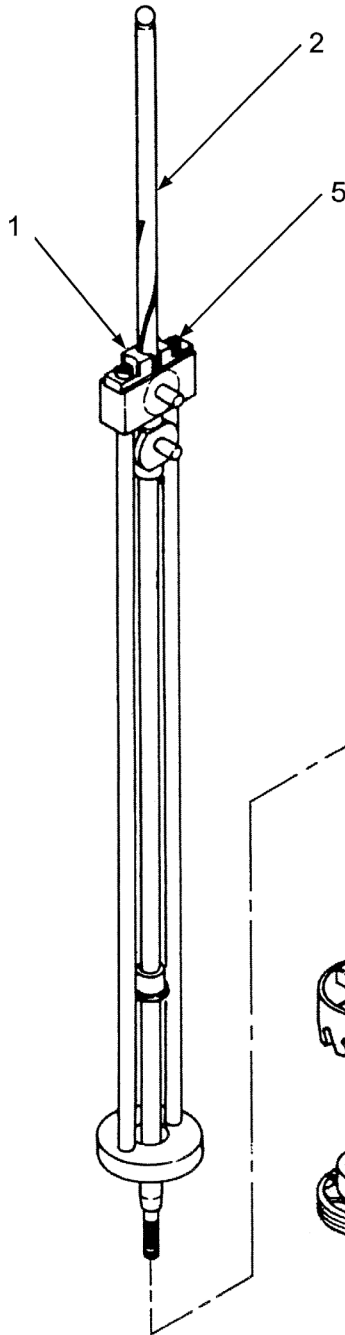

The French Plunger is a delicate, precision piece of equipment and must be handled with extreme care.

Before each use, put one drop of good quality food grade lubrication oil on the gibs (1), so the grooved center rod (2) can slide easily.

After each use, unscrew the lower piston (3) and remove the former (4). Thoroughly wash and dry all parts. Dip the bottom of the plunger in fry shortening before reassembly of the former (4) and the lower piston (3). Reassemble as shown. Apply cooking oil to the assembly to prevent rust.

To Avoid Damage:

- Do not handle roughly
- Do not drop on hard surfaces
- Do not wash in the same sink as other utensils.
- Keep all parts coated with cooking oil to prevent rust.

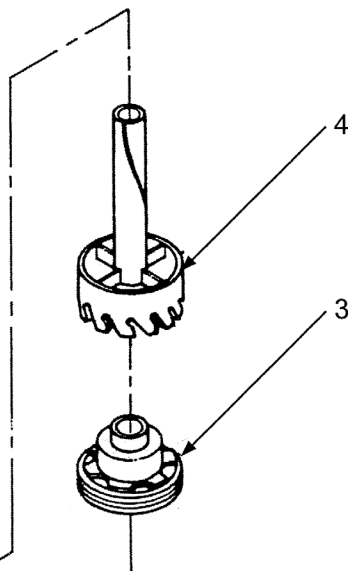

TRIP ARM ADJUSTMENT ON "B" & "F" CUTTERS

If the machine gets jammed, the trip arms may go out of adjustment. The following procedure should be used to check and readjust the trip arms.

1. Set the dial to #3 (maximum).
2. Turn the cutter by hand until the lower trip arm is at its lowest position.
3. Check dimension "A" (see illustration). If necessary, bend the lower trip arm to attain this dimension (11.063").
4. Turn the cutter until the upper trip arm is at its lowest position.
5. Check dimension "B" (see illustration). If necessary, bend the upper trip arm to attain this dimension (12.53").
6. Turn the cutter until the dial pointer is pointing straight down. Check dimension "C." Turn the cutter until the dial pointer is pointing straight up. Check dimension "D." If either "C" or "D" is not correct, parts may be worn and should be replaced.

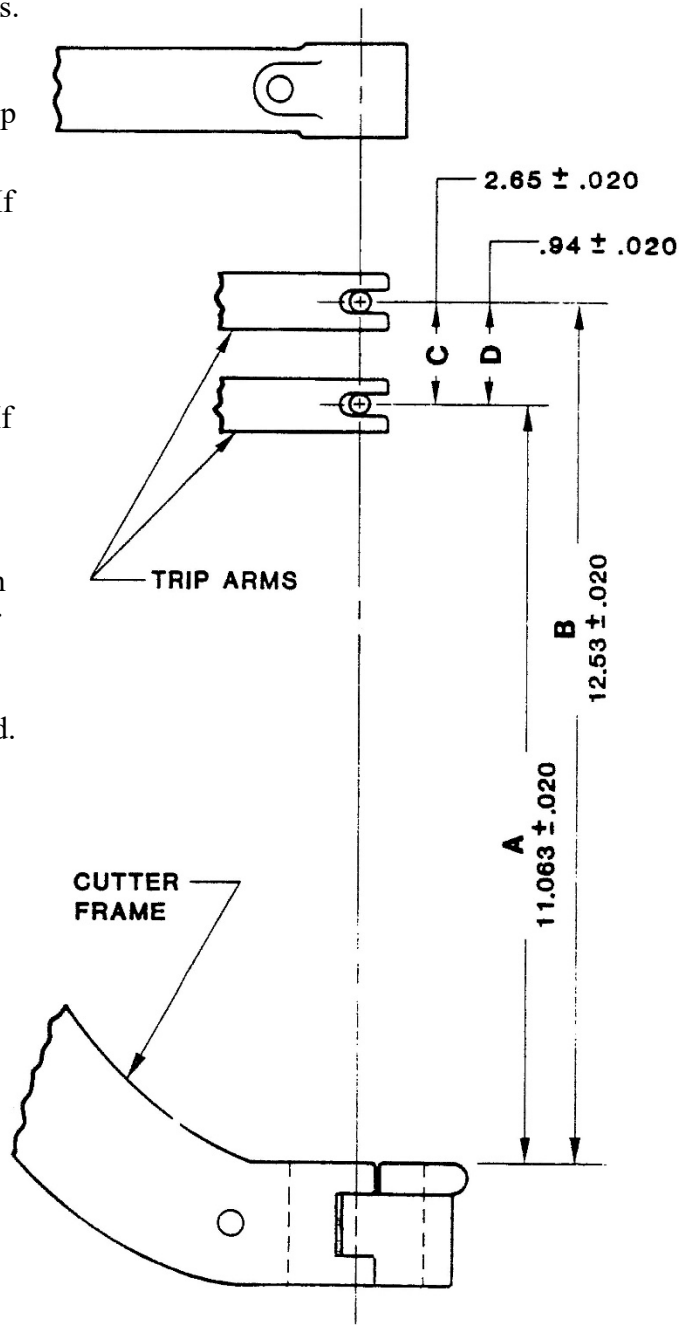

SB-18

#0400 HEIGHT ADJUSTMENT KIT INSTALLATION INSTRUCTIONS

#0400 Kit consists of the following:

- A. #0247 Thrust Washer
- B. #0316 Outer Sleeve Assembly
- C. #0246 Inner Sleeve
- D. 5/16-18 X 1/2 Square Head Set Screw

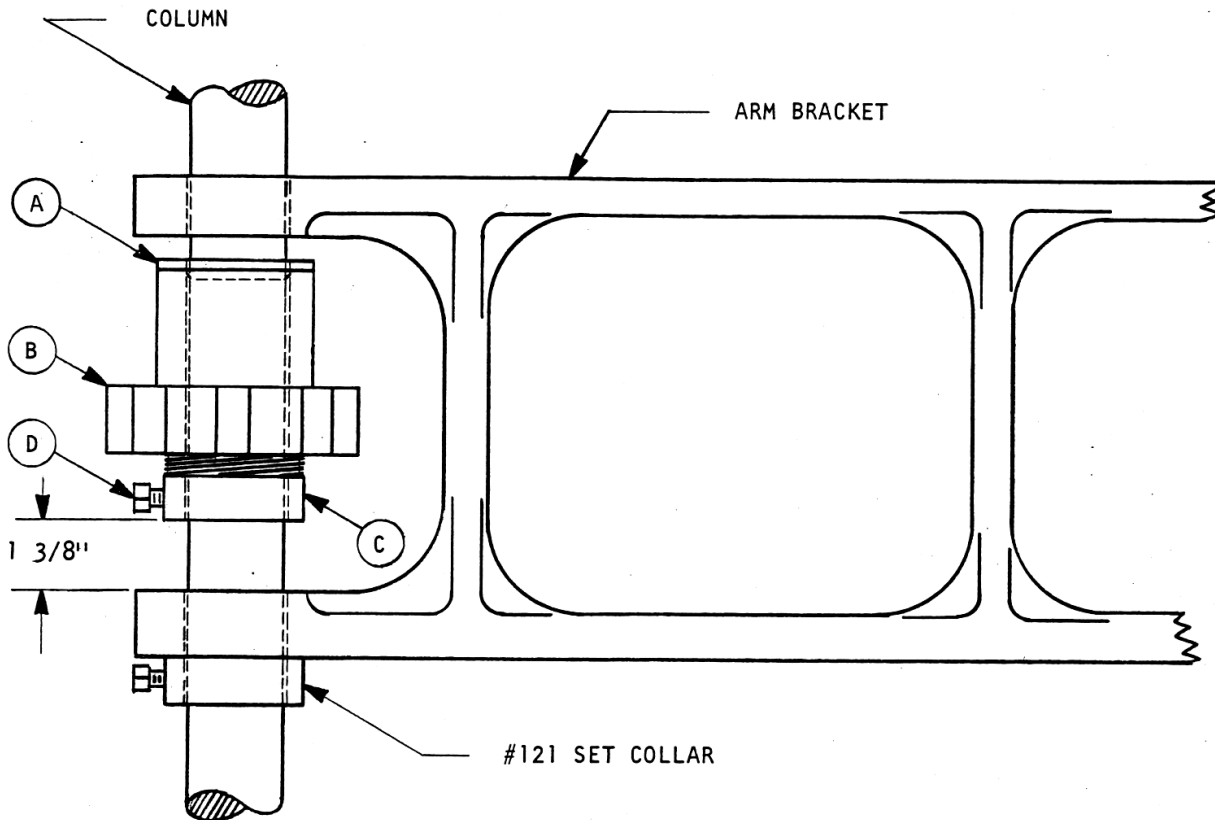

1. Assemble the kit components, arm brackets, and #0121 set collar together as shown in the above drawing.
2. With the cutter mounted in place on the pivot arm bracket, adjust the #0121 set collar to position cutter at the proper height:
 - A. The guard flange of the hopper base when mounted on the machine should just clear the rim of the fryer.
 - B. The bottom of the cutter should be 1" to 1 1/4" from the surface of the shortening.
3. Raise the height adjustment assembly (A, B, C and D) to achieve a distance of 1 3/8" between the Bottom of "C" and the arm bracket. Tighten set screw "D".

TYPE B / TYPE F COLUMN MOUNT

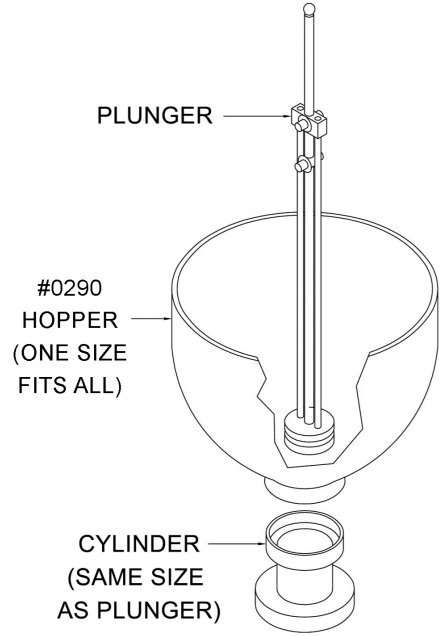
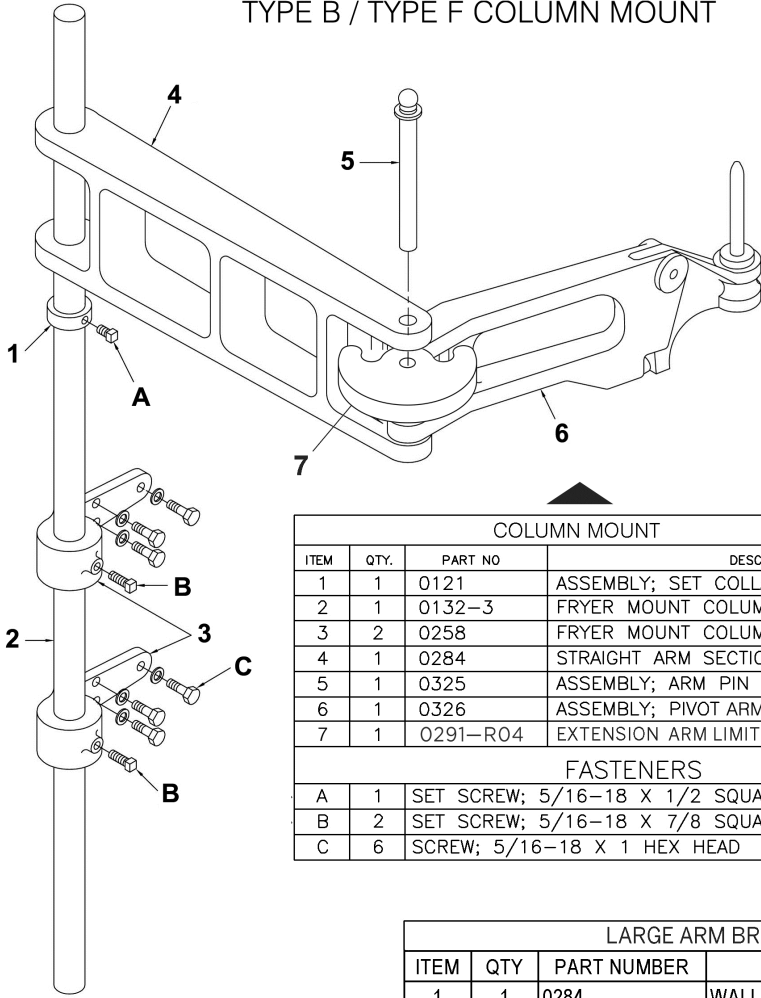

COLUMN MOUNT			
ITEM	QTY.	PART NO	DESCRIPTION
1	1	0121	ASSEMBLY; SET COLLAR
2	1	0132-3	FRYER MOUNT COLUMN
3	2	0258	FRYER MOUNT COLUMN BRACKET
4	1	0284	STRAIGHT ARM SECTION
5	1	0325	ASSEMBLY; ARM PIN
6	1	0326	ASSEMBLY; PIVOT ARM
7	1	0291-R04	EXTENSION ARM LIMITING BRACKET

FASTENERS			PART NUMBERS
A	1	SET SCREW; 5/16-18 X 1/2 SQUARE HEAD	903-1315
B	2	SET SCREW; 5/16-18 X 7/8 SQUARE HEAD	903-1310
C	6	SCREW; 5/16-18 X 1 HEX HEAD	903-1330SS

LARGE ARM BRACKET			
ITEM	QTY	PART NUMBER	DESCRIPTION
1	1	0284	WALL ARM SECTION
2	2	971-0017	BRG, FL 1-1/8X3/4X1-9/32
3	2	971-0018	BRG, FL 5/8X3/4X23/32

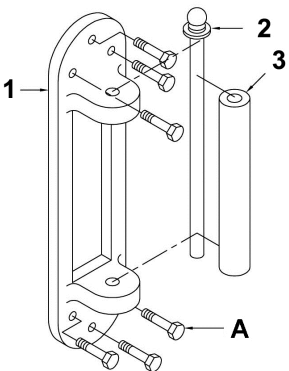
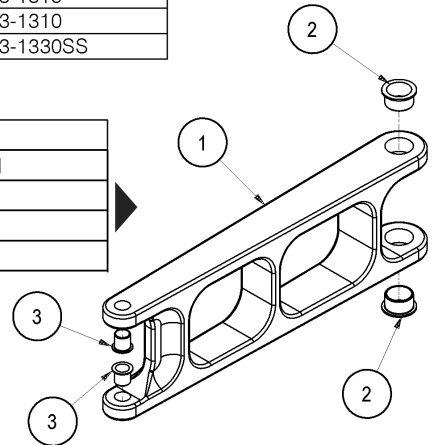

TYPE B / TYPE F WALL MOUNT

WALL MOUNT			
ITEM	QTY.	PART NO	DESCRIPTION
1	1	0004	WALL PLATE
2	1	0011	ASSEMBLY; WALL ARM PIN
3	1	0120	WALL ARM SECTION BUSHING

FASTENERS			PART NUMBER
A	6	SCREW; 5/16-18 X 1 1/2 HEX HEAD	903-1345

6

Parts Info

Drawings and Parts Lists in this section are for reference only. See the Parts List Drawing Insert for part numbers.

Parts List Drawing Insert Page

Title: B Cake Donut Cutters
Model: B
Item Number: B0001000 B-LB-W/O
Final Assembly Drawing: B0001000 Final Assy BOM Only
Sub Assemblies: 0226CHS B-LB-W/O-X without plgr/cyl/hpr
0324B Type "B" Frame Assembly

OPTIONAL MOUNTING KITS

Wall Mount: 0406 Wall Mt Brkt Kit (See Technical Supplement-Page 18)
Column Mount: 0405 B Column Mounting Kit (See Technical Supplement-Page 18)

BILL OF MATERIAL	
ITEM	DESCRIPTION
1	HINGE CLAMP BOLT
2	HINGE PIN
3	FRAME MACHINE TYPE "B & F"
4	FRAME COVER; TYPE B AND F; MACHINED
5	HINGE CLAMP (MACHINED)
6	HINGE CLAMP BOLT-HOLDER PIN
7	SCREW, HHMB, 1/4-20X1 SS
8	SST ROUND HEAD SLOTTED 1/4-20 UNC X 1.75
9	NUT, WING, 1/4-20, SST
10	5/16-18 UNC, WING NUT, ZINC PLATED
11	SST, 5/16 FLAT WASHER, REGULAR

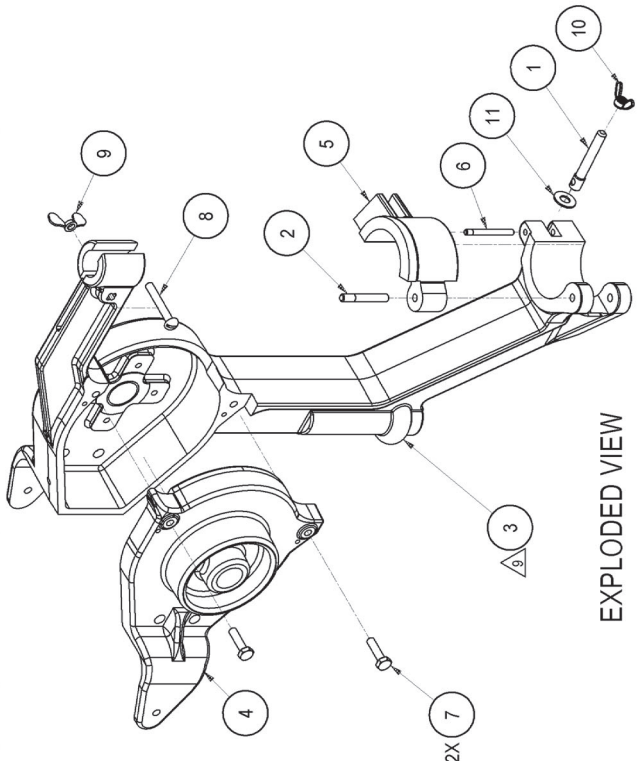

EXPLODED VIEW

- NOTES:
- UNLESS OTHERWISE SPECIFIED CHAMFER ALL HOLES BOTH SIDES 45°-.020" DEEP
 - DE-BURR AND BREAK ALL SHARP EDGES R.010 MAX.
 - REMOVE PHOSPHATES.
 - SAND BLAST FINISH 125-250, μ IN DO NOT SAND BLAST THREADED COMPONENTS.

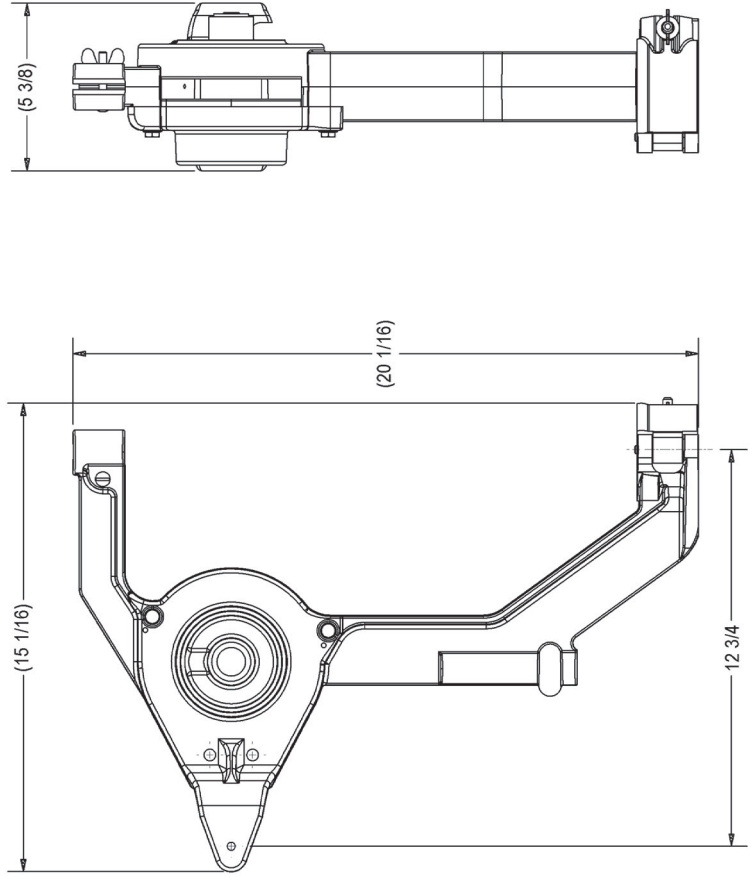

REV	ECR#	DESCRIPTION	DRAWN	APPROVED	DATE
5	14172	DELETE 978-009; RE-SORT BOM.	SER	MJP	06/22/15
6	14986	REVISE WITH UPDATED 0280F & 0281F	T-MR	MJP	11/15/12
7	15849	ADD GRINDING AND SAND BLASTING NOTES	SER	RAH	09/10/14
8	16204	RE-PRINTED DRAWING TO SHOW A SHORTER SLOT IN 0280F, ERROR LOADING REVISED MODEL HAD TO RE-DRAW.	SER	MJP	06/22/15
9	2606	MODIFIED 0280F	CJN	JH	11/18/20

Belshaw
www.belshaw.com
Adamatic
www.adamatic.com

BELSHAW ADAMATIC BAKERY GROUP, SEATTLE, WASHINGTON

TITLE: TYPE B & F FRAME

MATERIAL: SEE B.O.M.
SCALE: 1.4
DO NOT SCALE DRAWING

DATE: 06/22/15

APPROVED: MJP

DRAWN: MJP

SER: MJP

DATE: 06/22/15

SCALE: 1.4

DO NOT SCALE DRAWING

DATE: 06/22/15

APPROVED: MJP

DRAWN: MJP

SER: MJP

DATE: 06/22/15

SCALE: 1.4

DO NOT SCALE DRAWING

ITEM	QTY	PART NUMBER	DESCRIPTION
1	1	0024CHS	B CHS SHAF-T CAM ASSY
2	1	0026	CROWN BEARING
3	2	0027B	TRIP ARM ASSY
4	1	0111CHS	F SLEEVE CAM CHS
5	1	0112M	DIAL, MACH ASSY
6	2	0119B	TRIP ARM PIVOT PIN
7	1	0170N	DIAL CLAMP BOLT ASSY (B, F, & N)
8	1	0254	NYLATRON SS WASHER
9	1	0295	DIAL LOCK NUT
10	1	0292	HANDLE (PLASTIC)
11	1	0324F	TYPE B & F FRAME
12	1	0328	CRANK HANDLE ASSY
13	2	DR42-0116-3	WOODRUFF KEY
14	1	LBL-0040	LABEL, SERIAL TAG / F
15	1	TM100-0264	NSF LABEL

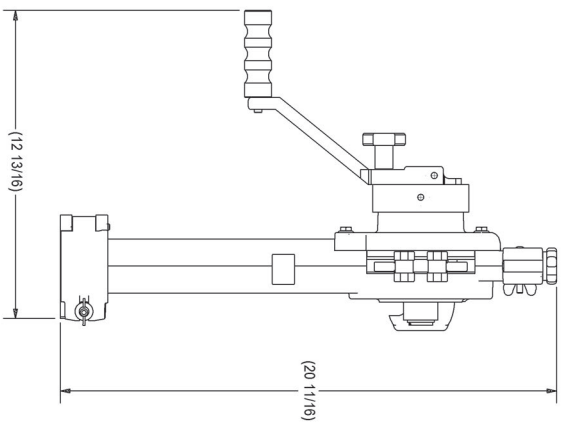
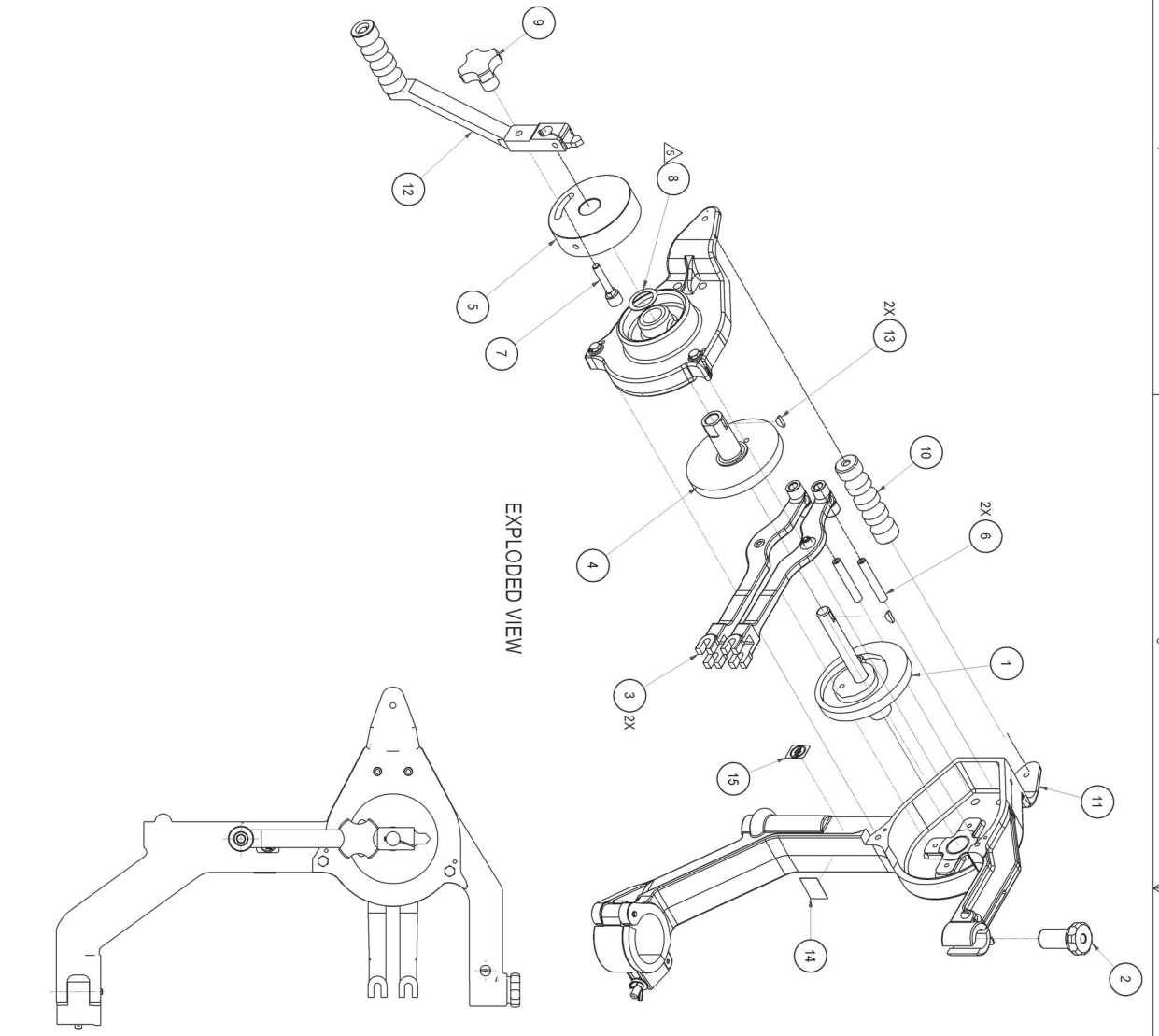

NOTES:

1. B STYLE FRAME AND ASSEMBLY UPDATE EFFECTIVE WITH SERIAL NUMBER F-101, NOVEMBER 3, 2010. ITEM 13 CHANGED TO 0324F EFFECTIVE WITH SERIAL NUMBER B258, OCTOBER 6, 2011.

REV	ESCH	DESCRIPTION	DATE	APPD	MR
1	12977	REWORK, REPLACE DIA WITH 0112; REPLACE DIA WITH 0328	02/10/10	LCP	
2	14082	TRIP ARM WAS 0328 & LBL-0040 WAS LBL-0399. REV TITLE, REV DIM	09/19/11	TRAO	
3	14116	REV TITLE, ADD NOTES	9/27/11	AB	
4	14142	ADD EFFECTIVE DATE AND DIM FOR BOM CHANGE. MAKE DIM REF	10/07/11	AB	
5	2891	REWORK BOM, ADD 0324 TO BOM	05/02/11	JS	

BOLTSHAW BROTHERS INC., SEATTLE, WASHINGTON

TITLE: B LB W/O PL3RCY/LNPR

DATE: 02/10/10

SHEET: 1 of 1

SEE D.O.M. DRAWINGS: 0226CHS

REV: R05

Belshaw Adamatic Bakery Group

Limited Warranty / Return Policy

Subject to the terms and limitations set forth in this limited warranty ("Limited Warranty"), Belshaw Adamatic Bakery Group (also referred to as "the Manufacturer") warrants to the original purchaser ("Purchaser") of Manufacturer's equipment and parts ("Products"), Belshaw Adamatic Bakery Group's manufacture and assembly of Products to be free from defects in workmanship and material which would result in product failure under normal use and service. Belshaw Adamatic Bakery Group's entire liability under this Limited Warranty is limited to either repairing or replacing at Manufacturer's factory or on Purchaser's premises, at Belshaw Adamatic Bakery Group's option, any Products purchased by Purchaser which shall be determined by the Manufacturer to be defective. If necessary to return Products to Manufacturer's factory, Products must be shipped by Purchaser with transportation charges prepaid by Purchaser.

Belshaw Adamatic Bakery Group reserves the right to make changes in design or add any improvement to its Products at any time without incurring any obligations to install the same on Products previously sold.

Possession, use or operation of Products sold hereunder for any other than their designed purpose, or use of Products which are in poor repair, modified, improperly operated, or neglected, is done at the Purchaser's risk. Belshaw Adamatic Bakery Group hereby disclaims any liability for these actions and shall not be liable for defects in or for any damages or loss to any property which is attributable to such actions.

Under no circumstances shall Belshaw Adamatic Bakery Group be liable for any indirect, special, incidental, or consequential damages arising out of, or from the use of its Products by Purchaser, its assignees, employees, agents or customers.

THIS LIMITED WARRANTY SHALL BE PURCHASER'S SOLE AND EXCLUSIVE REMEDY WITH RESPECT TO DEFECTIVE PRODUCTS.

Warranty Period

This Limited Warranty covers Products manufactured by Belshaw Adamatic Bakery Group and sold by Belshaw Adamatic Bakery Group or its authorized distributor ("Distributor") or authorized dealer ("Dealer"), and this Limited Warranty shall extend for a period of one (1) year from date of shipment to Purchaser, and to the original Purchaser only.

Limited Warranty

With respect to products not manufactured by Belshaw Adamatic Bakery Group, warranty coverage shall be limited to the warranty of the original manufacturer of the product, or the Belshaw Adamatic Bakery Group Limited Warranty, whichever is the lesser coverage period.

Replacement Products provided under the terms of this Limited Warranty are warranted for the remainder of the original warranty period applicable to the Product.

Exclusions

This Limited Warranty excludes from its coverage and does not apply to: (a) solenoid and relay coils; (b) lamps; (c) "O" rings; (d) belts; and (e) impellers. This Limited Warranty also excludes the cost of labor for removing and replacing Products subject to a warranty claim, other than the labor incurred directly by the Manufacturer when, in Belshaw Adamatic Bakery Group's opinion, a repair of the Product by the Manufacturer is justified.

Warranty Claims

In case of warranty claims relating to your Product, you must follow the instructions below.

Report Claims to Your Authorized Distributor or Dealer or to Belshaw Adamatic Bakery Group

As soon as you discover a problem, contact the Distributor or Dealer from whom you purchased the Product or Belshaw Adamatic Bakery Group. Your Distributor or Dealer will notify Belshaw Adamatic Bakery Group for you. **Only Belshaw Adamatic Customer Service can approve or authorize warranty claims.**

You must state the following:

1. Your name, company name, and telephone number
2. The location, phone number, and contact name where the Product is located
3. The invoice number and date of purchase of the Product
4. The Model and Serial Number of the Product, as written on the data tag attached to the Product
5. A description of the problem and how it occurred

Shipping Damage and Missing Items

Damage to the Packaging or Crate. On delivery, promptly check all packages thoroughly for any sign of damage. In cases of visible damage, **always note the damage on the Delivery Receipt.** Failure to note damage is taken by the Freight Carrier to mean that the package is in good condition at time of receipt, and can result in denial of a Freight Claim. Take photographs that clearly show the damage.

Damage to Products. If you find any damaged Product inside the shipment, photograph the damage both inside and outside of the package. Do not throw the packaging away. Photos of the package and contents are needed to show the condition of the Product at the time it was received.

Missing Items. As soon as you believe any items to be missing from a shipment, promptly report this to the Distributor or Dealer from whom the Product was purchased or to Belshaw Adamatic Bakery Group. If possible, photograph the entire contents of the delivery and email this to your Distributor or Dealer, or to Belshaw Adamatic Customer Service at service@belshaw.com.

Returning Products to Belshaw Adamatic Bakery Group

Under the terms of the Limited Warranty, you may be asked to return to Belshaw Adamatic Bakery Group any Product that is the subject of a warranty claim. These Products must be clearly labeled with a Return Goods Authorization Number ("RGA Number") given to you by your Distributor or Dealer, or by Belshaw Adamatic Customer Service. Products received without an RGA Number will not be processed. All Products must be shipped freight prepaid by the Purchaser to Belshaw Adamatic Bakery Group at the address below.

Contacting Belshaw Adamatic Bakery Group

At any time, you can contact Belshaw Adamatic Bakery Group customer service for assistance:

Belshaw Adamatic Bakery Group Customer Service
814 44th St. NW, Suite 103,
Auburn WA 98001, USA
Phone: 800-578-2547 (USA/ Canada) or (+1)253-886-5340
(Worldwide)
Email: service@belshaw.com
Office Hours: Monday – Friday, 6am to 4pm, USA Pacific Time