

OPERATION AND SERVICE MANUAL FOR **Walmart** ✱

## **Thermoglaze Donut System**

### **Model: TG-50**

208V, 1-phase, 32.2 A, 6.7 KW

Item Number **22306W**

Alternate Item #

Serial Number

*Insert your Serial Number above*



## **4 Bowl Icer**

### **Model: H&I-4**

208V, 1-phase, 6.5 A, 1.7 KW

Item Number **84900124**

Alternate Item #

Serial Number

*Insert your Serial Number above*







**WAL-MART**

*Thermoglaze*

*Model TG 50*

**Operator's Manual**

Belshaw Adamatic Bakery Group

814 44<sup>th</sup> Street NW, Suite 103

Auburn, WA 98001 USA

Phone: (206) 322-5474 • Fax: (206) 322-5425

Toll Free: 1-800-578-2547

Email: [service@belshaw.com](mailto:service@belshaw.com) • <http://www.belshaw-adamatic.com>

**Congratulations on buying a new Thermoglaze from Belshaw Adamatic Bakery Group Please inspect the unit carefully for damage or missing pieces immediately after receiving your system.** Belshaw cannot pay for shipping damage, because the freight company has accepted the machine from Belshaw in good condition, and is responsible for its safe delivery.

**For your protection, each crate should be inspected before signing the Bill of Lading to report any visible damage caused by the trucker in transit, and account for the number of crates.**

### EQUIPMENT RECORD

Please provide the information below when you correspond with us about your machine.

Purchased by \_\_\_\_\_

Installed by \_\_\_\_\_

Date of Installation \_\_\_\_\_

Model number \_\_\_\_\_

Serial number \_\_\_\_\_

060313

MN-1720WM

Belshaw Adamatic Bakery Group

814 44<sup>th</sup> Street NW, Suite 103

Auburn, WA 98001 USA

Phone: (206) 322-5474 • Fax: (206) 322-5425

Toll Free: 1-800-578-2547

Email: [service@belshaw.com](mailto:service@belshaw.com) • <http://www.belshaw-adamatic.com>

# Contents

<b>1</b>	<b><i>Unloading and Uncrating</i></b>	<b>1</b>
<b>2</b>	<b><i>Installation</i></b>	<b>2</b>
<b>3</b>	<b><i>Assembly</i></b>	<b>3</b>
<b>4</b>	<b><i>Operation</i></b>	<b>6</b>
	SB-0345 R1	8
<b>5</b>	<b><i>Cleaning</i></b>	<b>8</b>
	Disassembly	14
	Cleaning	18
	Assembly	19
<b>6</b>	<b><i>Maintenance</i></b>	<b>17</b>
<b>7</b>	<b><i>Troubleshooting</i></b>	<b>21</b>
<b>8</b>	<b><i>Appendix</i></b>	<b>24</b>
	SB-0361	27
	Parts List Drawing Insert Page	Insert

# Preface

The operator of the Thermoglaze is expected to behave safely, read this manual before operation, and follow its instructions and warnings.

Study the instructions and warnings in this manual carefully before operating the equipment. A thorough understanding of how to install, maintain, and safely operate the Thermoglaze will prevent production delays and injuries. Prior operation of the equipment before reading and understanding the instructions in the manual will void the warranties of the equipment.

To use the Thermoglaze safely, heed the following warnings and all other warnings that appear in this manual:

- To avoid damaging the Thermoglaze, never use force to assemble, disassemble, operate, clean, or maintain it.

# 1 Unloading and Uncrating

## DO NOT LIFT EXCESSIVE WEIGHT

Once the crate has been delivered, immediately take the covers off the crate and inspect for hidden damage. If damage is found, make a damage claim to the shipping company. After inspection, cut the banding and remove any other restrains from the Thermoglaze unit. Remove the banding and other packing material from the Thermolizer unit. Roll the Thermolizer, carefully, off the skid first and move it near the area where it will be assembled. Roll the Thermoglaze unit, carefully, off the skid and move it near the area where it will be assembled.

**Do not connect the Thermoglaze or the Thermolizer to electrical power before completing the assembly and placement of the products.**

Figure 1-1 shows the system in the crate ready to be unpacked. The cartons under the Thermoglaze contain the glaze trough. See Section 4 to assemble the unit. The carton in the Thermolizer contains the doors and other interior parts. See Thermolizer manual for assembly instructions.

The Thermoglaze system has been designed for quick assembly and installation. Within a short time of receiving the system, the installer can have the Thermoglaze ready to make donuts if the electrical connections are properly installed and inspected by the prevailing local authorities.



Figure 1-1 Packed Thermoglaze System

# Installation

# 2

## WARNING

To avoid electrocuting yourself or damaging the Thermoglaze, never allow water, steam, cleaning solution, or other liquid to enter the electrical panels or connections

## Electrical:

Model	Dimensions	Power Requirements
TG50	88"L x 40W x 63"H	See data tag

Make sure that the power requirements of the Thermoglaze, shown on the data plate, match your power source.

Only plug in to power source that matches the required voltage and current for the Thermoglaze. (The Thermoglaze unit TG50 comes standard with a Hubbel 360P6W plug that needs a 360C6W socket or equivalent for electrical current.

Thermoglaze must be electrically grounded and connected in compliance with the National Electrical Code, ANSI-NFPA 70, and applicable municipal building codes.

Do not apply electrical power to the system until the assembly has been completed. See Section 4 for the assembly of the Thermoglaze.

## Venting:

Local codes prevail. The authorities having jurisdiction are stated in NFPA 96-1994 regarding requirements for the Thermoglaze.

## Building Layouts:

Specification sheets and AutoCAD drawings for use in developing architectural drawings can be provided by request. Please call your Belshaw Adamatic Bakery Group representative for help in defining your requirements.

# Assembly

# 3

**Clean all parts with mild soap and water and let dry before assembly and applying electrical power to the equipment.**

The Thermoglaze unit is design for ease of assembly and use. The system is crated in a manner so there are few pieces to put together once the Thermoglaze is in place for production.

After unpacking the system per the uncrating instructions, 1 item needs to be placed on the Thermoglaze to finish assembly: the glaze

trough. The Glaze trough slips into the 2 holes on either side of the drain tray with the waterfall headed toward the oven. See figure 3-1 and 3-4 for help setting the trough in place. After the trough is in place attach the glaze hose to the trough by pushing it in the hose mount in the center of the trough.

To help familiarize you with your Thermoglaze, please study the following photographs:



Figure 3-1 Thermoglaze front view



Figure 3-2 Right Hand View:



Figure 3-3 Control Panel View:

**WARNING**

**TURN OFF POWER SOURCE TO THE MACHINE BEFORE REMOVING ANY ACCESS COVER OR GUARDS**

The Thermoglaze system consists of a Thermoglaze unit and the Thermolizer. They are placed in unison in the area located for the production of donuts. See Figure 4-6 for Thermoglaze system.



Figure 3-5 Thermoglaze System.

**WARNING**

**DO NOT CONNECT THE THERMOGLAZE TO ELECTRICAL POWER BEFORE COMPLETING THE ASSEMBLY PLACEMENT OF PRODUCTS**

# Operation

# 4

- Turn on oven power switch and allow to heat to operating temperature. (**Note: conveyor will not move until the oven is up to operating temperature and the donut ready light is on.** See Figure 4-1.)



Figure 4-1. Oven Ready Light.

- Load glaze reservoir with 40 pounds (one large bucket) of glaze and turn on the glaze pump.

## WARNING

Do not operate glazer without glaze or water in the pump. Doing so can cause permanent damage to the pump.

- After the donuts have been in the Thermolizer for at least 20 minutes (60 minutes for filled product), turn on glazer using the on switch located on the main control panel.
- After the donuts are thawed, place a screen of donuts from Thermolizer box to the infeed end of the Thermoglaze conveyor and allow the screen to travel through the oven and glazer. This takes approximately 1-1/2 to 3 minutes.

- When the screen of donuts is through the glazer and stopped forward travel, place the glazed product on a rack for cooling using the 2 delrin tray grips provided with the unit.

## WARNING

To avoid burning yourself, never touch the Thermoglaze unit, conveyor, or interior of the oven while the machine is in use.

## WARNING

Thoroughly clean and dry the floor if water or other materials are spilled. Materials spilled on the floor may cause serious injury and loss of life.

## WARNING

Conveyor will automatically start when Thermoglaze reaches operating temperature.

## CAUTION!

Donut screens are hot after coming out of the glazer and will burn you if you grab them without the handles.

## CAUTION!

To avoid burning yourself, never touch the hot infeed oven end panel when the machine is in operation.

---

**CAUTION!**

To avoid burning yourself, never touch hot screens when the machine is in operation.

**WARNING**

Lifting the glaze bucket may cause sprains or back injury.

**WARNING**

Serious personal injury may result from contact with pinch points between chain, sprockets and pulley. Cuts or loss of limb may occur when contacting these pinch points. Never operate the machine with guards and covers removed.

**CAUTION!**

To avoid burning yourself, never touch the hot conveyor chain when the machine is in operation.

**CAUTION!**

To avoid burning yourself, never touch the hot outfeed oven end panel when the machine is in operation.

**CAUTION!**

Serious personal injuries, such as scratches or cuts, may result from contact with sharp edges.

**CAUTION!**

Reaching across or leaning over the machine may result in burns when the machine is in operation.

# Cleaning

5

## Daily TG Cleaning Instructions

### Disassembly

1. Allow the Thermoglaze to completely cool. (All material must under 130°)
2. Pump the unused glaze back into a bucket.
3. **Disconnect the TG from power!**
4. Remove the glaze trough.



5. Remove the drive belt.



6. Remove the glazer drain tray.



7. Disconnect the conveyor drive coupling.



8. Remove the conveyor assembly through the outfeed end of the oven.



### WARNING

Failure to wash the conveyor chain **daily** may cause damage to the conveyor drive motor. The Thermoglaze will shut down if the chain becomes stiff from glaze buildup. After cleaning, the motor reset button may need to be pressed, located under the control panel.

9. Remove the oven crumb tray.



10. Open the safety cover.

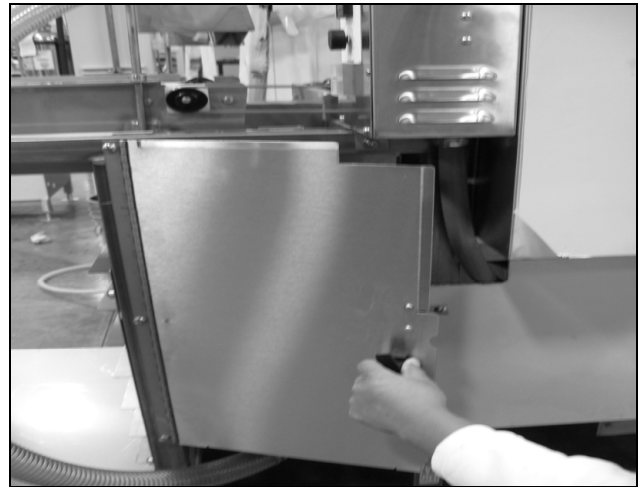

11. Loosen the lower glaze hose clamp.



12. Remove the lower glaze hose clamp and gasket.



13. Remove the upper pump clamp.



14. Lift the glaze reservoir and remove the gasket.



15. Remove the glaze reservoir and hose.



16. Remove the drip pan.

17. Unscrew and remove the 4 glaze pump cover wing nuts.



18. Remove the glaze pump cover and "O" ring.



19. Remove the glaze pump body.



- 
20. Insert a flat tip screw driver into the slot to loosen the pump body if it can not be removed by hand.



21. Remove the pump body and impellers.  
22. Remove the impellers from the pump body.

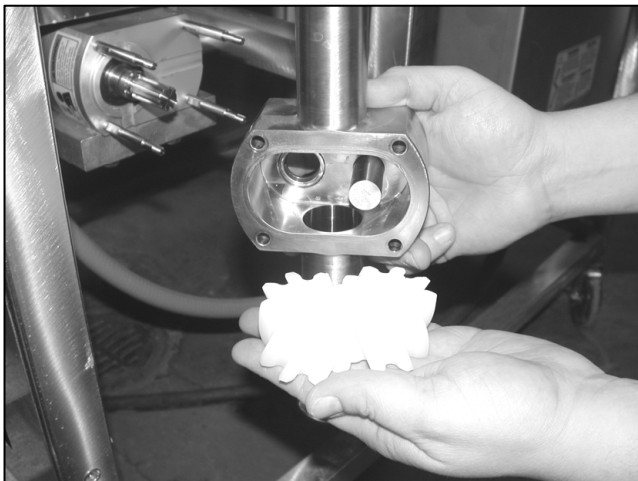

**WARNING**

Spilled glaze on the floor may cause slipping and falling, resulting in sprains, burns, broken bones or back injury.

## **Cleaning**

1. Hand wash all parts of the oven and glazer with warm soapy water.
2. Do not use caustic cleaners on oven parts.
3. You may use an approved oven cleaner on the stainless steel finger cover only.
4. Do not use oven cleaner on any other part of the oven or glazer!
5. Do not hose/spray down any part of this machine.

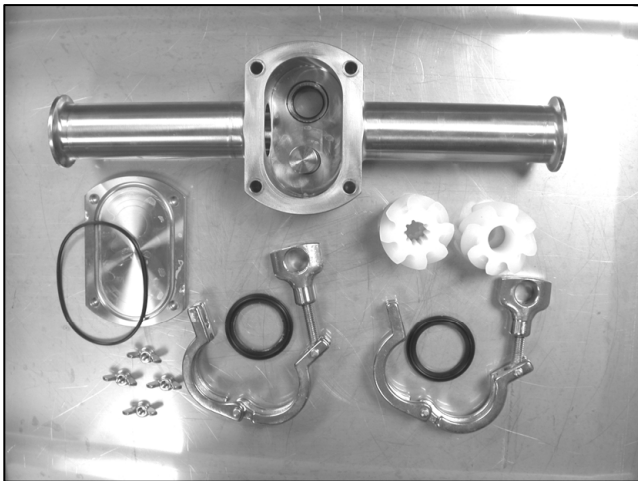

6. Glaze pump body and parts.

### **CAUTION**

Failure to properly clean or lubricate glaze pump may cause damage to the pump gear impellers.

7. Wash the conveyor and chain **daily** with warm soapy water to remove all glaze build-up on the chain.

### **NOTE**

Lubricate the Pump Body, Shaft “O” Ring, and gear impellers with “Kay” Food Grade Lubricant. See following picture.



## WARNING

Growth of organisms in gaps, crevices, glaze pump, lines, or frame can result from improper cleaning and can cause mild to serious ill health.

## WARNING

Donuts or filling may catch fire due to improper cleaning and can cause serious injury, burns, or death.

## Assembly

1. Install the glaze pump body.
2. Install the drive gear impeller. Line up the flat on the shaft with the flat in the impeller.

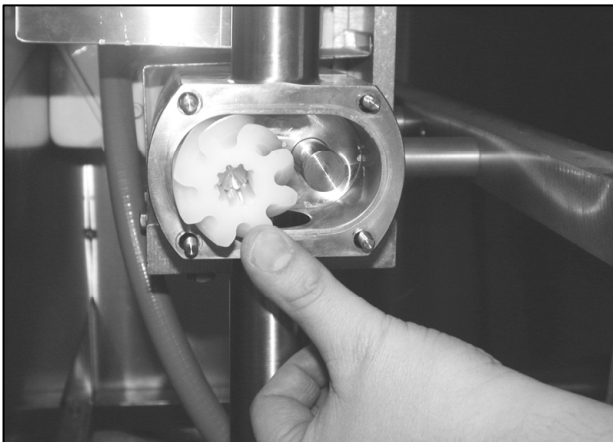

## NOTE

Lubricate the pump body, shaft “o” ring and gear impellers with food grade mineral oil.

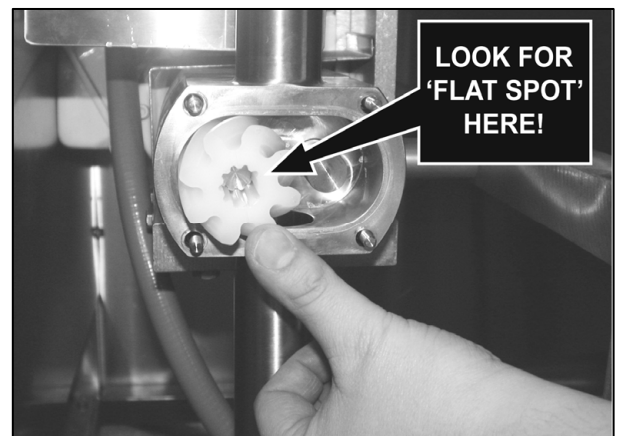

3. Install the lay gear impeller.



4. Install the “O” ring into the glaze pump cover. Make sure it stays in place and you do not pinch it between the pump and cover. The “O” ring may need to be stretched before installing.

5. Install the 4 wing nuts finger tight.



6. Set the upper gasket on top of the glaze pump.

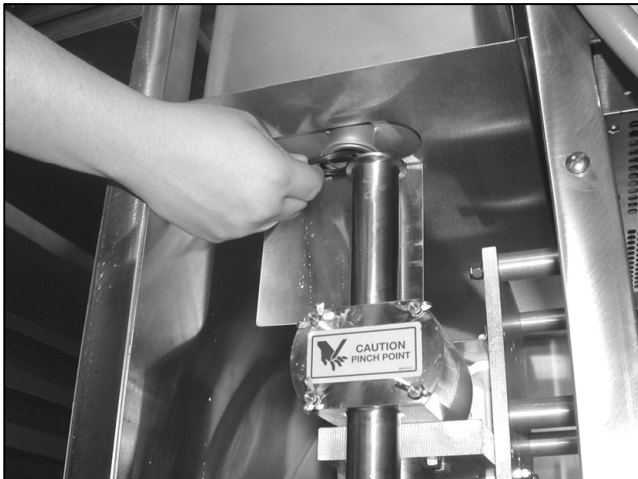

7. Install the glaze reservoir.



8. Install the upper clamp.



9. Install the lower gasket, hose and clamp.

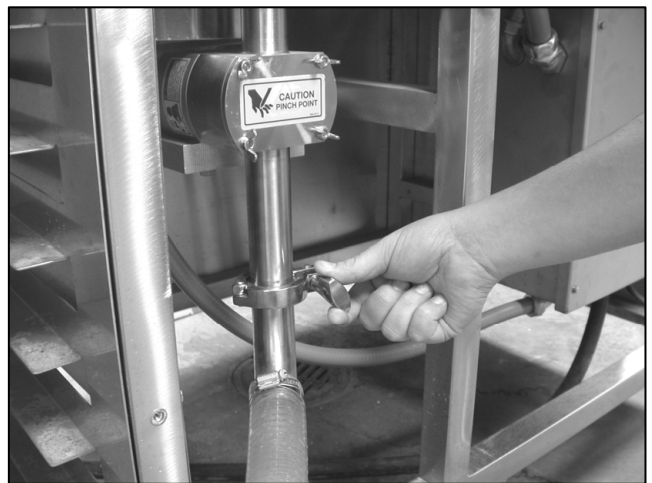

10. Close the safety cover. Make sure the key is in the safety switch.



**NOTE**

The glaze pump will not run with the safety cover open.

11. Install the oven crumb tray.

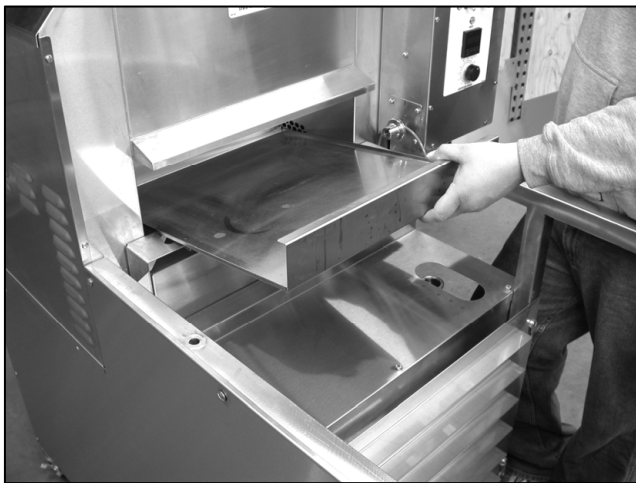

12. Insert the conveyor through the outfeed end of the oven.



13. Make sure the locating pin is in the matching hole.

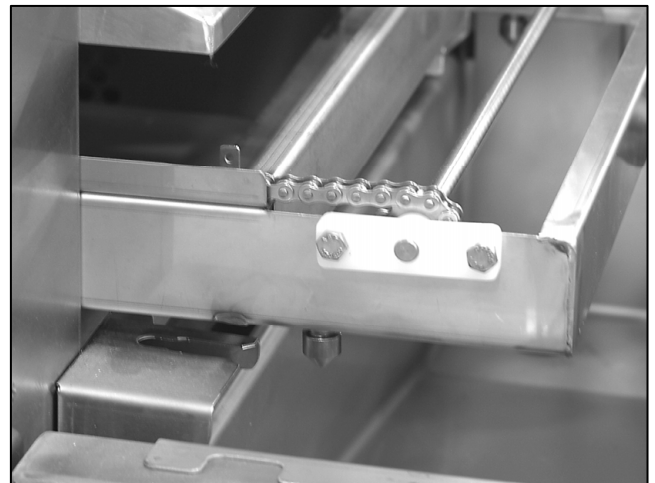

- 
14. Pull the drive coupling back and line it up with the conveyor drive shaft.



15. Install the glaze drain tray.



16. Connect the drive belt.
17. Install the rear panel by making sure the key attached to the rear panel is inserted into the safety interlock switch, then screwing in the thumb screw.

**NOTE**

The glaze pump will not run with the rear panel removed.

---

# Maintenance

# 6

The ThermoGlaze is engineered to need little maintenance. By keeping the system clean, the equipment will last for years. The only maintenance that is required is the following:

When cleaning the donut system, check all rubber gaskets for wear and replace when necessary. Check for wear on impellers of the glaze pump, replace when necessary. .

**DO NOT** spray machine with water or cleaning agents to clean. Only wipe main unit off with damp cloth.

## WARNING

### HAZARDOUS VOLTAGE

Contact with electricity in the control box can cause shocks, burns or death. Always disconnect the control box from power source before maintenance.

## WARNING

Contact with electricity in the main cable can cause shocks, burns or death. Always disconnect the main electrical cable from the power source before maintenance.

## WARNING

Electrical fires can cause serious shock, injury, burns or death. Always disconnect the machine from power source before maintenance.

## TG50 Temperature Controller Programming procedure

This service bulletin covers the procedure for programming the [TJ-0184C-1](#) (Omron E5CC-RX3DM-000) temperature controller used in a TG50.

The [TJ-0184C-1](#) controller comes per-programmed and protected so the operator cannot change the setup parameters. To change any setting you must first unlock the controller.

**Note:** Only the settings that are changed from the Factory settings are listed below.



To unlock the controller:

1. Press the + keys for more than 3 seconds
2. Press the key to move to the next parameter
3. Press the or to change the parameter  $\bar{\Delta}P\bar{L}$  and  $\bar{\Sigma}P\bar{L}$  from 2 to 0
4. Press the + keys for more than 1 second to return to operator screen





Parameter	Factory default setting	Present setting	Unit	Front panel	Explanation of present setting
<b>Protection parameters</b>					
Operation/Adjustment Protect	0	2	.	$\bar{\Delta}P\bar{L}$	2:Display and change of only "PV" and "PV/SP" parameters is allowed. [2]
Initial Setting/Communications Protect	1	2	.	$\bar{\Sigma}P\bar{L}$	2:Prohibited [2]

To change operator set points: (Must be unlocked to change Alarm Value 1)

1. Press the key to move to the next parameter
2. Press the or to change the parameter
3. Press the key to return to operator screen





<b>Operator set points</b>					
Set Point	0.0	420.0	°F	.	.
Alarm Value 1	0.0	0.5	°F	AL - 1	.

To change operator level parameters: (Must be unlocked)

1. Press the  key for less than 1 second
2. Press the  key to move to the next parameter
3. Press the  or  to change the parameter
4. Press the  key to return to operator screen





Operator level parameters					
Process Value Input Shift	0.0	-40.0	°F	2NS	<b>This is the offset setting for calibration</b>
Hysteresis (Heating)	1.0	0.5	°F	HYS	.

To change initial level parameters: (Must be unlocked)

1. Press the  key for move than 1 second to adjust intial parameters
2. Press the  key to move to the next parameter
3. Press the  or  to change the parameter
4. Press the  key for more than 1 second return to operator screen

Initial level parameters					
Input Type	5	8	.	2N-2	8:Thermocouple[J] (-20.0 to 400.0°C or 0.0 to 750.0°F) [8]
Temperature Unit	0	1	.	d-U	°F [F]
SP Upper Limit	130.0	420.0	°F	SL-H	.
SP Lower Limit	-20.0	0.0	°F	SL-L	.
Alarm 2 Type	2	0	.	AL2	0:Alarm function OFF [0]
Alarm 3 Type	2	0	.	AL3	0:Alarm function OFF [0]
Alarm 4 Type	2	0	.	AL4	0:Alarm function OFF [0]







To change advanced level parameters: (Must be unlocked)

1. Unlock the controller
2. Press the  key for more than 1 second to adjust intial parameters
3. Press the  key until you get to parameter *AMOV*
4. Press the  or  to change *AMOV* parameter to -169







Advanced level parameters					
Alarm 1 Latch	0	1	.	AL1	Enabled [ON]
PV/SP No. 1 Display Selection	4	1	.	SPd1	1:"PV/SP/No display" [1]
PV Decimal Point Display	1	0	.	PVdP	OFF [OFF]

---

After programming: To lock the controller:

1. Press the  +  keys for more than 3 seconds
2. Press the  key to move to the next parameter
3. Press the  or  to change the parameter  $\bar{\alpha}RPt$  and  $\bar{\zeta}LPt$  from 0 to 2
4. Press the  +  keys for more than 1 second to return to operator screen

To set the controller back to factory default settings: (Must be unlocked, see page 1)

1. Press the  key for more than 1 second to adjust initial parameters
2. Press the  key until you get to parameter  $RM\bar{\alpha}'$
3. Press the  or  to change  $RM\bar{\alpha}'$  parameter to -169
4. Change parameter  $\bar{\zeta}N\bar{\zeta}t$  from  $\bar{\alpha}FF$  to  $FRLt$
5. Press the  key for more than 1 second return to initial screen
6. Press the  key for more than 1 second return to operator screen

Please do not hesitate to contact Belshaw Adamatic Bakery Group for additional assistance at (206) 322-5474, (800) 578-2547 or e-mail at [service@belshaw.com](mailto:service@belshaw.com).

# Troubleshooting

# 7

Call Belshaw Bros. at (206)322-5474, or (800) 578-2547. One of our customer support representatives will be happy to help you. When you call, please specify the following:

- The model name of the machine.
- The serial number of the machine.
- The voltage, phase, and hertz (cycle) of the machine. This information can be found on the small, rectangular data tag/plate.

## CAUTION

If you perform repairs yourself or have them performed by anyone other than Belshaw Bros. or a service technician authorized by Belshaw Bros., you do so at your own risk.

Following is a troubleshooting chart to help you identify and solve some basic problems.

## WARNING

Disconnect the machine from the power source before disassembling, repairing, or wiring.

## WARNING

To avoid serious injury, always disconnect the Thermoglaze from the power source before troubleshooting.

<b>CONVEYOR WILL NOT MOVE</b>	
<b>Possible Causes</b>	<b>What To Do</b>
Oven not to correct temperature yet.	Wait until the oven comes to temp.and the ready light comes on.
Conveyor is jammed.	Check for obstruction in conveyor and remove.
Motor circuit breaker is tripped.	Push the black circuit breaker reset at bottom of oven control panel.
<b>GLAZER WILL NOT PUMP GLAZE</b>	
Glazer motor is not running.	Check to make sure the motor is running.  (See Pump Motor Will Not Run)
Glazer pump impellers are worn.	<ol style="list-style-type: none"> <li>1. Disconnect power.</li> <li>2. Replace impellers.</li> </ol>
The rear panel safety key is not inserted in the safety switch.	Make sure the rear panel safety key is inserted into the safety switch.
<b>GLAZE IS MISSING THE DONUTS ON ONE SIDE OF THE GLAZE SCREEN</b>	
Glazer or glaze trough is not level.	Adjust level of glaze trough by moving set collar.
Glaze pump is running too slow.	<ol style="list-style-type: none"> <li>1. Disconnect from power.</li> <li>2. Open Electrical Enclosure.</li> <li>3. Turn glazer speed control clockwise.</li> <li>4. Close Electrical Enclosure.</li> </ol>

<b>THE PUMP MOTOR WILL NOT RUN</b>	
<b>Possible Causes</b>	<b>What To Do</b>
The connection of the power cord to the power source is faulty.	Make sure the power cord is fully plugged in to a proper power source.
The circuit breaker has been tripped.	<ol style="list-style-type: none"> <li>1. Disconnect from power.</li> <li>2. Open electrical enclosure.</li> <li>3. Reset circuit breaker.</li> <li>4. Close electrical enclosure.</li> </ol>
The rear panel is not installed properly	<ol style="list-style-type: none"> <li>1. Reinstall the rear panel.</li> <li>2. Make sure that the key attached to the rear panel is inserted into the safety interlock switch.</li> </ol>
	<b>NOTE</b>
	The glaze pump will not run with the rear panel removed.
<b>THE FILL HOSE IS LEAKING</b>	
<b>Possible Causes</b>	<b>What To Do</b>
Fill hose is leaking at the connection.	Hose bracket needs adjusting or tightening.
Fill hose is leaking near the pump.	Check for missing or damaged o-ring.

# Calibration Procedure for Temperature and Cook Time on the Thermoglaze Model TG50

Turn off power to the TG50 before removing any access covers. This procedure should be performed only by qualified service technicians. Remove the electrical box cover on the oven to access the temperature and speed control

adjustment potentiometers. The following is a photo of the location of the adjustment potentiometers for the temperature and cooking time for the Belshaw TG50 Thermoglaze.

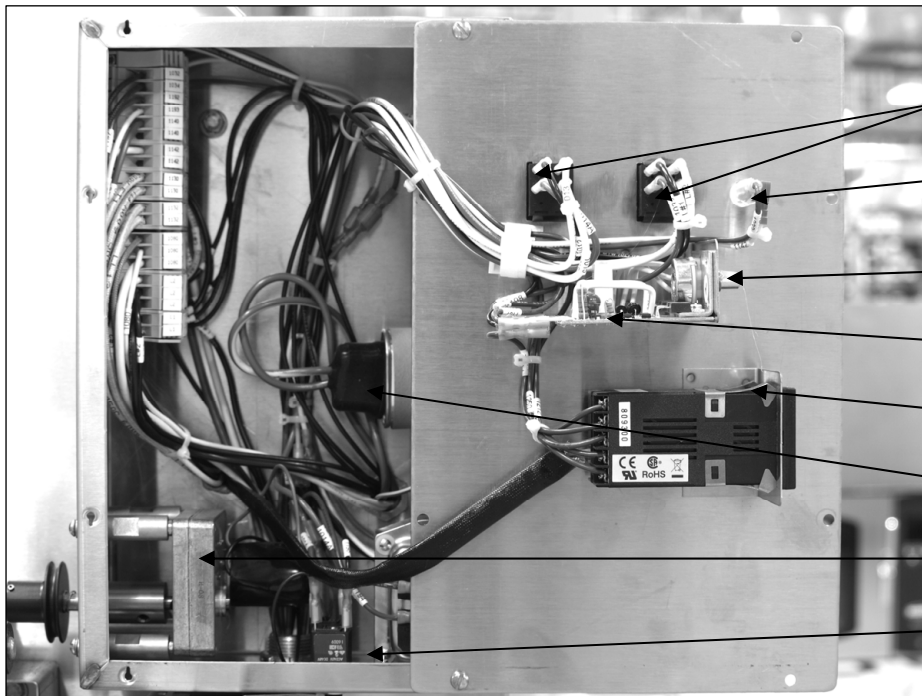

- Rocker Switches
- Donut Ready Light
- Speed Controller
- Conveyor Drive Board
- Temperature Controller
- Transformer
- Conveyor drive motor
- Reset Breakers for Pump and Conveyor

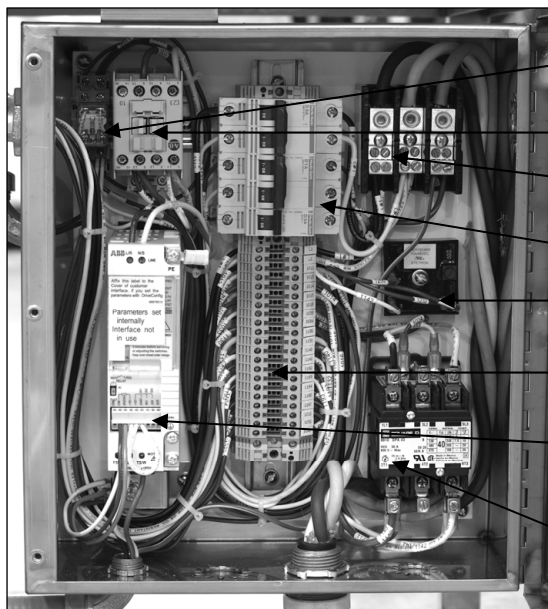

- Conveyor Relay
- Heater Contactor
- Power Distribution Block
- Circuit Breakers
- Time Delay Relay
- Terminal Block
- VFD
- MCR



Glaze Pump

## Speed control/cook time adjustment:

Turn on the oven and allow it to heat for 30 minutes.

Put a glaze screen on the conveyor chains that run through the oven. With the oven in operation, time the leading edge of the screen as it enters the oven until the leading edge just leaves the exit end of the oven. Adjust the potentiometer until the desired time/speed is found. To increase the cook time, turn the potentiometer clockwise. To decrease the cook time, turn the potentiometer counterclockwise. The factory setting for cook time for the TG50 is 1 ½ minutes.

## Temperature Adjustment:

Measure the temperature from the lower baffle on the exit end of the oven. Place a thermocouple in the hole located on the baffle, 3<sup>rd</sup> row from the outside, 3<sup>rd</sup> hole from the back side of the oven.

**Note:** The back side of the oven has a fan motor extended from it. Adjust the temperature by rotating the potentiometer located to the right of the speed control, clockwise increases the temperature, and counterclockwise decreases the temperature. The factory setting is 400° F.

## Glaze Pump VFD Setup

The glaze pump VFD (ABB model ACS55) does not require any programming. All parameters are factory set via dipswitches and potentiometers as shown on sheet 2 of the electrical schematic.

For older TG-50's with the Telemecanique VFD see SB-0315R3 for programming and trouble shooting

### NOTE

**PUMP COVER CAN BE REMOVED WITHOUT TOOLS.**

EN



21

### Status indications and fault tracing

ACS55 has two status indication LEDs, visible through the front cover.

If the drive detects a problem, the red LED will blink. After fixing the problem, reset by switching the start signal off. If start is off already, turn it first on and then off again.

See the table below for the fault codes (= the number of LED blinks).

Green LED	Red LED	Description
On	Off	ACS55 operates normally.
On	Blinking On  Off 	Protective function has been activated. Number of blinks indicates the fault code.
Blinking	Blinking	ACS55 will reset automatically within 3 seconds. (*) <b>Warning!</b> Motor starts, if start signal is on.

#	Possible causes and what to do	#	Possible causes and what to do
1	DC overvoltage (*). 1) Mains voltage is too high: Check supply. 2) Deceleration ramp time is too short compared to the load inertia: Increase ACC/DEC time with potentiometer.	6	Analogue input value is less than 4 mA/2 V. (*) <b>Note:</b> This supervision is active if AI OFFSET is ON.
2	DC undervoltage (*). Mains voltage is too low: Check supply.	7	Motor overload ( $I^2t$ overload): 1) Check the load, and verify that the motor size is suitable for ACS55. 2) Verify that setting of MOTOR I NOM potentiometer is correct.
3	Output short circuit: Switch off the power and check the motor windings and motor cable.	8	Inverter overload or excessive internal temperature: 1) Load is too high or 2) drive cooling is insufficient.
4	Output overcurrent. 1) Acceleration time is too short compared to the load inertia: Increase ACC/DEC time with potentiometer. 2) Motor and drive sizes do not match: Check motor.	9	Other fault. Internal error. Turn power off and on again. If problem persists, replace the unit.
5	Reserved	10	Parametrization fault. <b>Note:</b> Both LEDs will blink. DIP switches have been moved from default setting after the drive has been parametrized with DriveConfig tool. Put the switches back to default position.

---

# Appendix

8

Service Bulletin SB-0361

**WARNING:** Special Cleaning Instructions

Parts List Drawing Insert Page.

---

## SERVICE BULLETIN SB-0361

**This is a maintenance advisory for all owners of Thermoglaze TG-25 and TG-50 machines.**

Belshaw has recently been informed of conveyor chain binding and/or failures on these machines. We have addressed the problem by inspecting machines during assembly, and by testing and inspecting chains returned to us from the field.

We have concluded that almost all of these problems can be avoided if the recommended maintenance procedures from the manual be strictly adhered to.

A label (TG-9031) is included with this service bulletin and it should be placed on your machine in a prominent area that will easily remind all employees of the necessity to maintain and clean this equipment. ***Please note – equipment failure caused as a result of not following these maintenance and cleaning instructions will not be covered under warranty.***

Specifically – The conveyor **MUST** be removed from the unit and thoroughly cleaned with water and a mild detergent to remove all glaze, and any other contaminants, **DAILY**. See manual for more information.

---

# **Daily TG Cleaning Instructions**

## **Disassembly**

1. Allow the Thermoglaze to completely cool. (All material must under 130°)
2. Pump the unused glaze back into a bucket.
3. **Disconnect the TG from power!**
4. Remove the REAR panel by unscrewing the thumb screws
5. Remove the glaze trough.
6. Remove the drive belt.

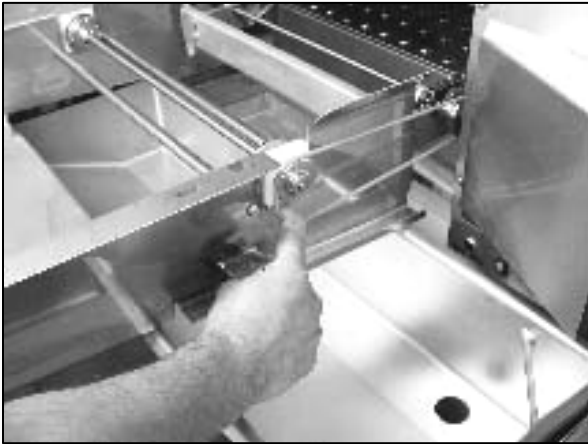

7. Remove the glazer drain tray.



- 
8. Disconnect the conveyor drive coupling.



9. Remove the conveyor assembly through the outfeed end of the oven.



10. Remove the oven crumb tray.



11. Remove the safety cover.



### WARNING

Failure to wash the conveyor chain **daily** may cause damage to the conveyor drive motor. The Thermoglaze will shut down if the chain becomes stiff from glaze buildup. After cleaning, the motor reset button may need to be pressed, located under the control panel. **NOTE – THE SERVICE CALL TO FIX THIS PROBLEM WILL NOT BE COVERED UNDER WARRANTY.**

# Parts List Drawing Insert Page

**Title:** Thermoglaze

**Model:** TG50

**Item Number:** 22306W TG50-S-208,60,1-W

**Final Assembly Drawing:** TG-2018 Mechanical Assembly Drawing

**Sub-Assemblies:** TG-1009 Transfer Shaft Assembly; Tg  
TG-1011 Conduit/Connector Assy; Tg  
**TG-1012** Drain Tray/Rail Assy  
TG-1504 Assy; Oven  
TJ-1004 Glaze Pump Assy  
**TNGG-0526** Glaze Hose Assembly  
TG-0505 TG Motor Assembly

**Wiring Diagram:** TG-4006 Electrical Assy Drawing (TG-1705)



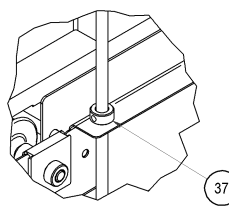
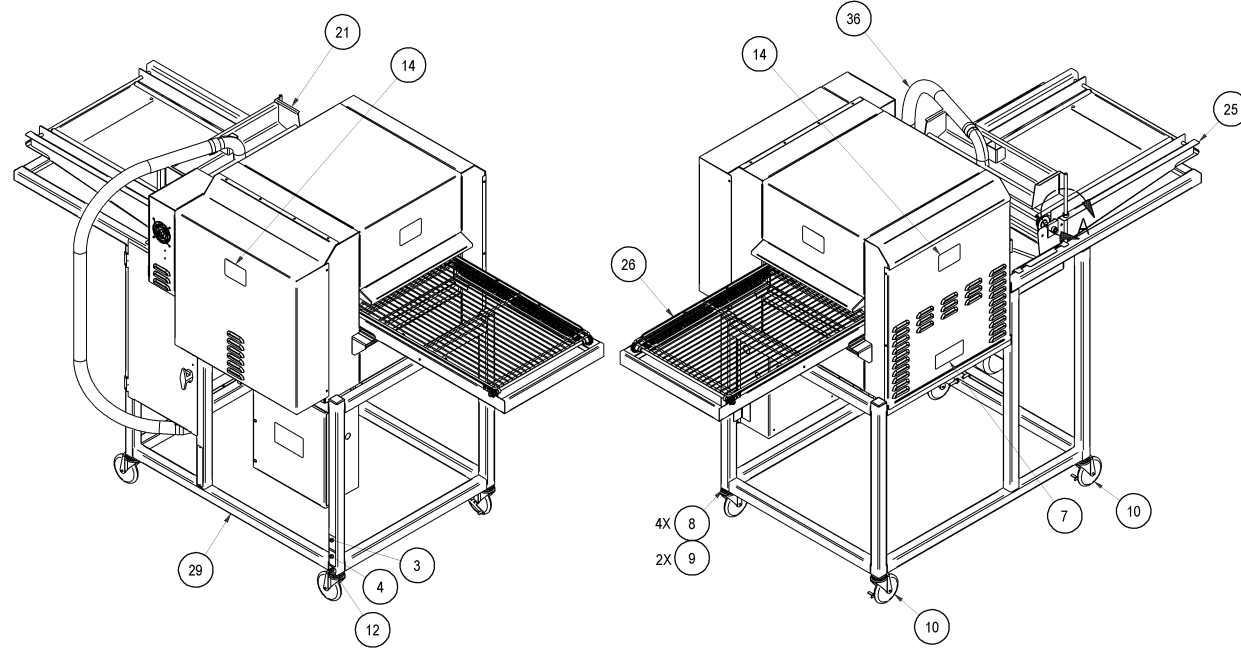

DETAIL A  
SCALE 1/3  
TYP 2X

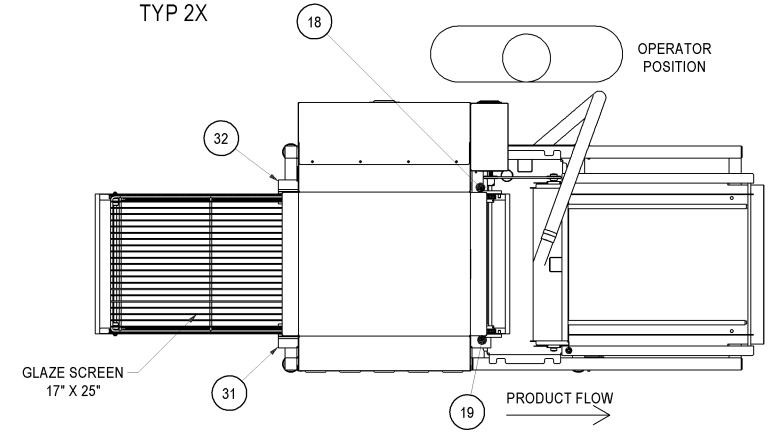

BILL OF MATERIAL			
ITEM	QTY	PART NUMBER	DESCRIPTION
1	3	--	SS SCW ROUND HEAD SLOTTED 10-24 UNC X 0.625
2	1	0158	DATA PLATE
3	1	904-0035	LABEL; ETL LISTED; NSF STD 4
4	1	904-0040	LABEL; ETL LISTED; UL STD 197
5	3	905-0339.10-24	10-24 INSERT NUT - BRASS
6	1	ENC-0126	SEALING GASKET; 11.98 X 14.43
7	1	EP18/24-0140	LABEL; BELSHAW LOGO
8	4	FT6-0118	CASTER SOCKET; 18 GA, 1.5 RT-POLY
9	2	HG18-0031-4	SWIVEL CASTER, 4"
10	2	HG18-0031B-4	SWIVEL CASTER W/BRAKE, 4"
11	1	I-0184	HANDLE ASSY
12	1	LBL-0023	LABEL; THERMOGLAZE; PATENT #7,137,334
13	2	MDD-0459	LABEL; WARNING; HAZ VOLTAGE
14	2	MK-0186	LABEL; CAUTION - HOT
15	1	REF	SPARE KEY FOR SWITCH (NOT SHOWN)
16	1	REF	SWITCH, SAFETY INTERLOCK
17	1	SWT-0036A	KEY, SWITCH
18	1	TG-0143	CONV. HOLD DOWN BRKT; BACK
19	1	TG-0147	CONV. HOLD DOWN BRKT; FRONT
20	1	TG-0180	LANYARD 304 SS EYE-EYE 24" LG (NOT SHOWN)
21	1	TG-0510	WLDT; GLAZE TROUGH; TG
22	1	TG-0535	WLDT; GLAZE TANK; 4.5 GALLON LB/RF
23	1	TG-1009	TRANSFER SHAFT ASSEMBLY; TG
24	1	TG-1011	CONDUIT/CONNECTOR ASSY; TG (NOT SHOWN)
25	1	TG-1012	DRAIN TRAY / RAIL ASSY
26	1	TG-1036	TRANSFER CONV ASSY - RF/LB OPERATE
27	1	TG-1504	ASS'Y; OVEN; WAL-MART
28	REF	TG-1705	ELEC ASSY; 208V-60-1. PIN & SLEEVE; WAL-MART
29	1	TG-8005	FRAME, WAL-MART, BASIC
30	1	TG-8006	DOOR; RF/LB OPERATE
31	1	TG-8010	CONV SUPPRT BRKT, FRONT
32	1	TG-8011	CONV SUPPRT BRKT, BACK
33	1	TG-9031	LABEL, WASH CONVEYOR
34	1	TJ-0194	BRKT.; CONTROL BOX
35	1	TJ-1004	GLAZE PUMP (G MODEL); UNDERMOUNT
36	1	TNGG-0526	GLAZE HOSE ASSEMBLY
37	2	TNGT-0120	SET COLLAR; 3/8" I.D. X 3/4" O.D.
38	2	TNGV-0060	TRAY GRIP (NOT SHOWN)

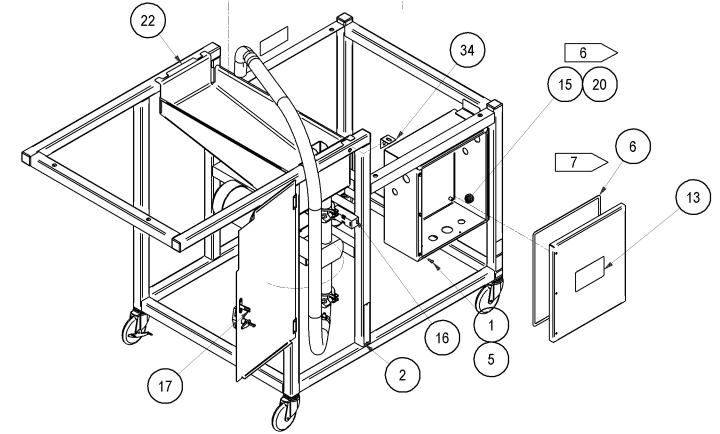
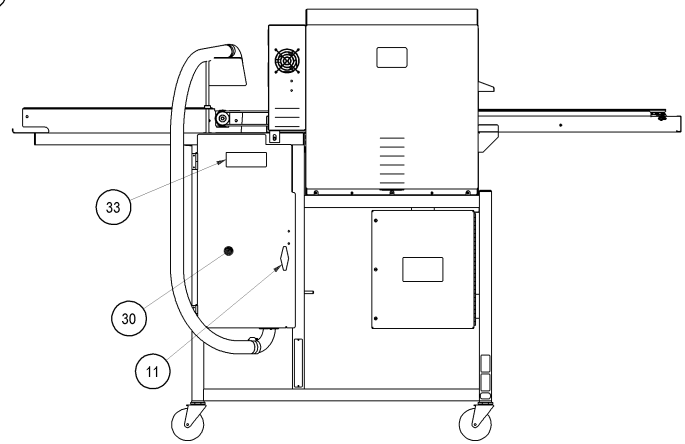
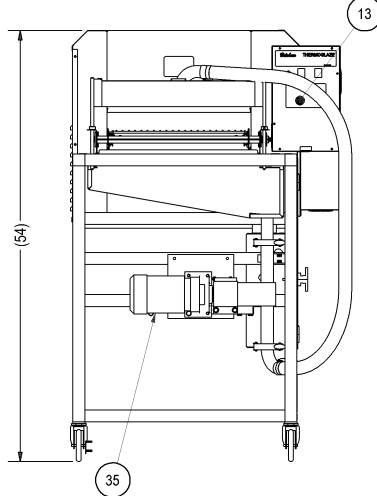
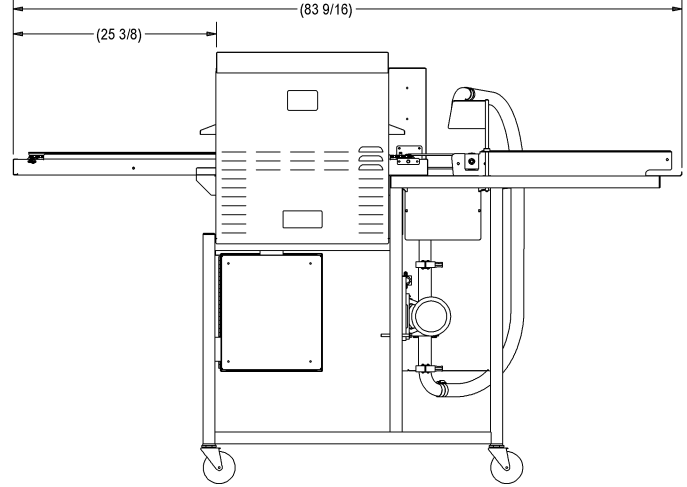
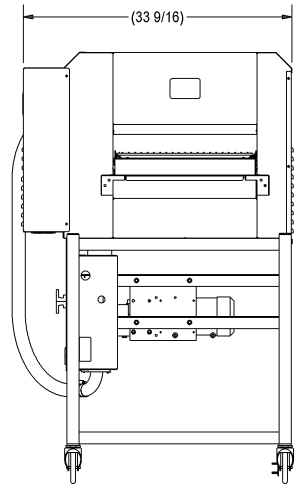
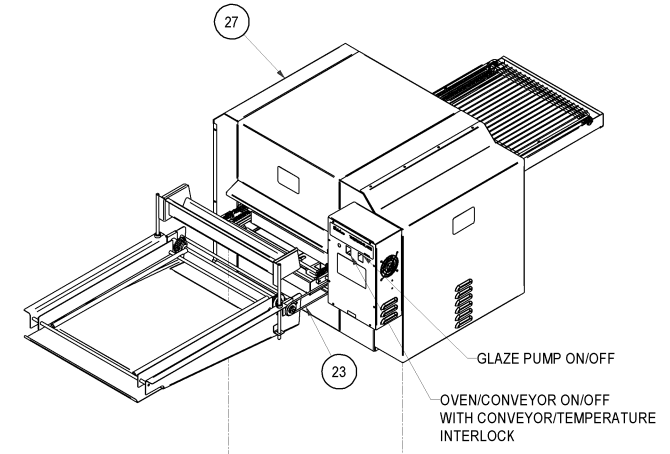

EXPLODED VIEW

- NOTES:**
- SEE W/D TG-4002 (208-60-1)
  - APPLY SILICONE SEAL TO FRAME & COVERS; SEAL ALL SEAMS AND OVEN TO FRAME & COVERS
  - SEAL AROUND INSIDE OF OVEN
  - OPTIONAL LINE ITEMS:  
SK-1257: SPARE PARTS KIT, THERMOGLAZE (SEND W/UNIT)  
SL200-0004: GLAZING SCREEN: 17 X 25
- 5 ATTACH SAFETY SWITCH ACTUATOR TO DOOR WITH Ø3/16 STAINLESS RIVETS
- 6 ATTACH LANYARD TO BOTTOM INSIDE OF ENCLOSURE AND OTHER END TO SPARE SAFETY SWITCH KEY
- 7 SPRAY FLAT SIDE OF GASKET WITH 3M SPRAY ADHESIVE. SPRAY INSIDE COVER OF ELECTRICAL ENCLOSURE WITH ADHESIVE. WAIT 3 MINUTES. PRESS THE 2 GLUED SURFACES TOGETHER.

**SPECIFICATIONS:**

THERMOGLAZE (TG-50)  
LB (LEFT BACK) OPERATE 50 DOZ/HR  
WIDTH - 84"; DEPTH - 33 9/16"; HEIGHT - 54"

GLAZING SCREEN SIZE: 17" X 25", 2 DOZ

OVEN CAPACITY: 50 DOZ/HR @ 90 SEC. HEAT TIME

POWER REQUIREMENTS: 208V, 60HZ, 1PH

REV	ECR#	DESCRIPTION	DRAWN	DATE	APPD	MFR	SCALE	DATE	SIZE	SHEET	TITLE
1	12553	UPDATE TG-8005; DEL TG-9144; RELOCATE EP18/24-0140; TG-8031	AB	6/04/09	AB		1:12	AB	AB	1	TG-2018
2	12635	DELETE TG-0180 FROM BOM	AB	8/14/09	AB						
3	12700	ITEM 31 TG-8010 WAS TG-9145; ITEM 32 TG-8011 WAS TG-9146; RE-SORT BOM	AB	10/06/09	AB						



SEE B O M  
DRAWING NUMBER  
TG-2018

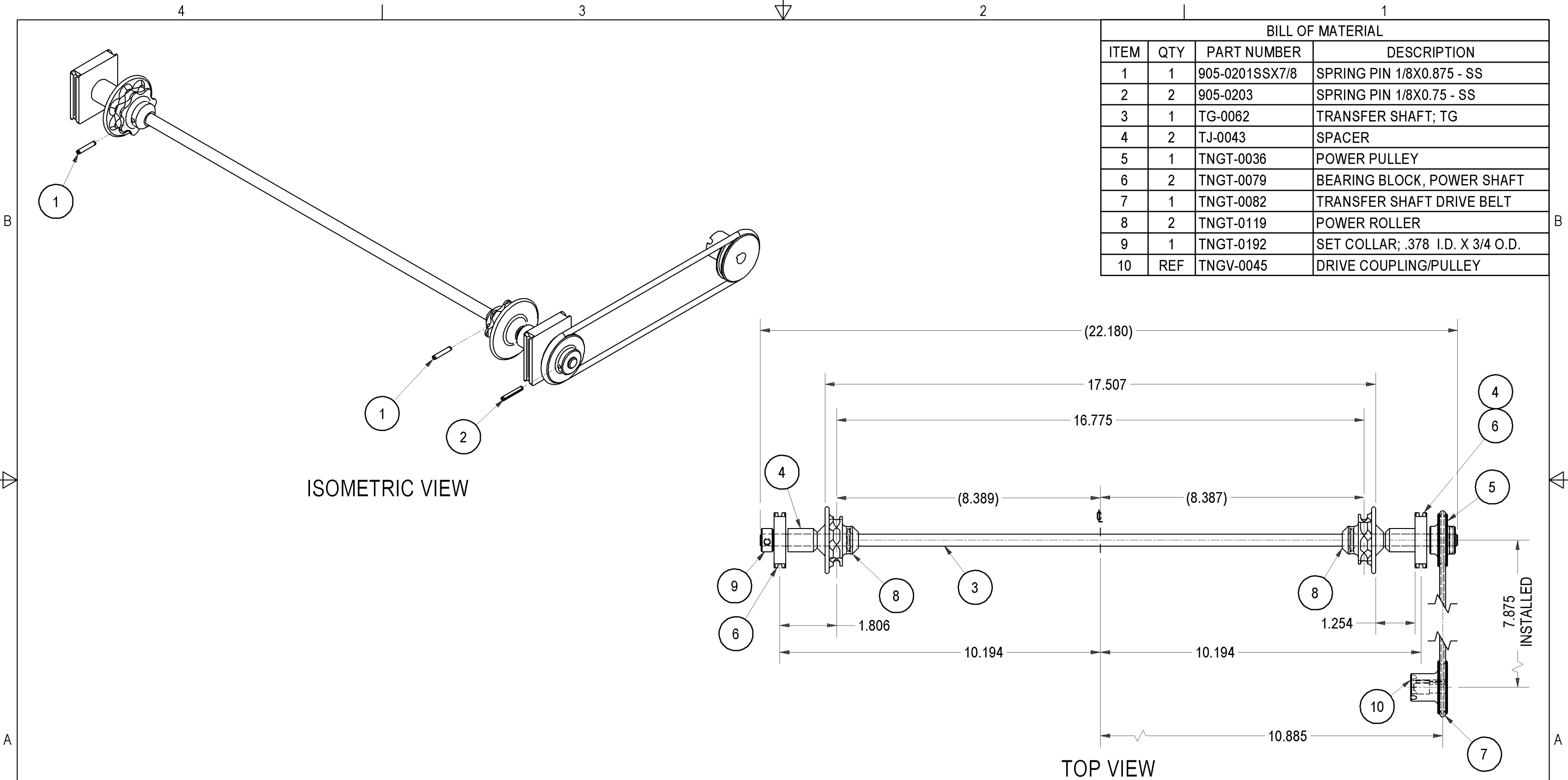

BILL OF MATERIAL			
ITEM	QTY	PART NUMBER	DESCRIPTION
1	1	905-0201SSX7/8	SPRING PIN 1/8X0.875 - SS
2	2	905-0203	SPRING PIN 1/8X0.75 - SS
3	1	TG-0062	TRANSFER SHAFT; TG
4	2	TJ-0043	SPACER
5	1	TNGT-0036	POWER PULLEY
6	2	TNGT-0079	BEARING BLOCK, POWER SHAFT
7	1	TNGT-0082	TRANSFER SHAFT DRIVE BELT
8	2	TNGT-0119	POWER ROLLER
9	1	TNGT-0192	SET COLLAR; .378 I.D. X 3/4 O.D.
10	REF	TNGV-0045	DRIVE COUPLING/PULLEY

REV	ECR#	DESCRIPTION	DRAWN	DATE	APP'D	MFR

THE INFORMATION CONTAINED IN THIS DRAWING IS THE SOLE PROPERTY OF BELSHAW BROS., INC. ANY REPRODUCTION IN PART OR WHOLE WITHOUT THE WRITTEN PERMISSION OF BELSHAW BROS., INC. IS PROHIBITED.

UNLESS OTHERWISE SPECIFIED, DIMENSIONS ARE IN INCHES  
TOLERANCES, UNLESS OTHERWISE NOTED:  
XX ± .132 ( ) = REFERENCE  
XX ± .030    .XXX ± .010  
ANGLE = ± 1'

**Belshaw**  
BELSHAW BROTHERS INC., SEATTLE, WASHINGTON

TITLE:  
**TRANSFER SHAFT ASSEMBLY; TG**

MATERIAL:  
SEE B.O.M.

DO NOT SCALE DRAWING

SCALE	DRAWN	APP'D	MFR	DATE	SIZE	SHEET	DRAWING NUMBER	REV
1:3	AB	LCP	SP	9/08/04	B	1 OF 1	TG-1009	--

G:\RELEASED DESIGNS\TG\TG-1009.dwg

2 BILL OF MATERIAL

ITEM	QTY	PART NUMBER	DESCRIPTION
1	1	990-0013	3/8 CONNECTOR 90° LIQ-TITE FLEX
2	1	990-0016	1" CONNECTOR 90° LIQ-TITE FLEX
3	1	990-0260-6	DIN RAIL 35MM X 7.5MM X 6" LG
4	1	990-0260-9.25	DIN RAIL 35MM X 7.5MM X 9.25" LG
5	2	990-0610-D	1/2 SEALING LOCKNUT
6	1	990-0700	NIPPLE, CHASE 1/2"
7	1	992-0002	SHC-1023 CORD CLAMP .375-.500
8	1	992-0026	CORD CLAMP .875-1.0
9	1	TNG-0114	BRACKET; POT
10	1	TNG-0113	PRE-WIRE PANEL; TG-50

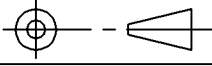
ECR	REV	REVISION	DRAWN	DATE	APP'D	MFG								
10426	1	ADD TJ-0189	REM	3/02/07	LCP		 <p>TOLERANCE UNLESS NOTED: X/X: ±1/32 ( ): REFERENCE .XX: ±.030 .XXX: ±.010 ANGLE: ±1°</p>	<p align="center"><b>BELSHAW BROS., INC.</b> SEATTLE, WASHINGTON</p> <p align="center">THE INFORMATION CONTAINED IN THIS DRAWING IS THE SOLE PROPERTY OF BELSHAW BROS., INC. COPYRIGHT BELSHAW BROS., INC. 2007. ANY REPRODUCTION IN PART OR WHOLE WITHOUT THE WRITTEN PERMISSION OF BELSHAW BROS., INC. IS PROHIBITED.</p>						
11005	2	DEL TJ-0189	AB	7/06/07	LCP			<p align="center">TITLE: CONDUIT/CONNECTOR ASSY; TG</p>						
							<p align="center">MATERIAL: SEE B.O.M.</p>							
							A DWG SIZE	NTS SCALE	AB DRAWN	9/24/04 DATE	LCP APP'D	SP MFG	TG-1011 DRAWING NO.	2
													SHEET 1 OF 1	

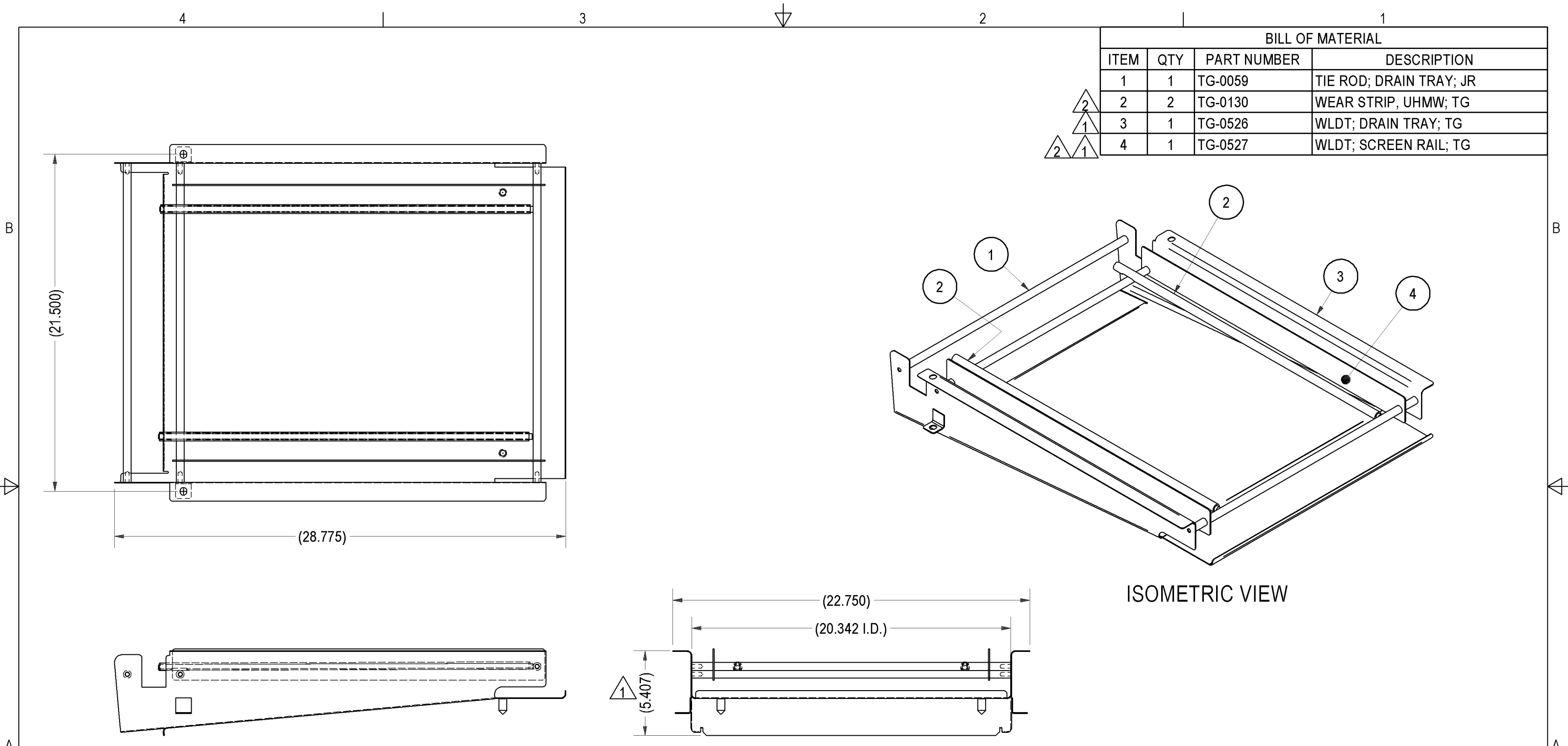

BILL OF MATERIAL			
ITEM	QTY	PART NUMBER	DESCRIPTION
1	1	TG-0059	TIE ROD; DRAIN TRAY; JR
2	2	TG-0130	WEAR STRIP, UHMW; TG
3	1	TG-0526	WLDT; DRAIN TRAY; TG
4	1	TG-0527	WLDT; SCREEN RAIL; TG

ISOMETRIC VIEW

REV	ECR#	DESCRIPTION	DRAWN	DATE	APPD	MFR
1	8611	UPDATE TG-0526, -0527; REV DIM	AB	12/22/05	LCP	SP
2	8900	UPDATE TG-0130, -0527	AB	2/24/06	LCP	SP

THE INFORMATION CONTAINED IN THIS DRAWING IS THE SOLE PROPERTY OF BELSHAW BROS., INC. ANY REPRODUCTION IN PART OR WHOLE WITHOUT THE WRITTEN PERMISSION OF BELSHAW BROS., INC. IS PROHIBITED.

UNLESS OTHERWISE SPECIFIED, DIMENSIONS ARE IN INCHES TOLERANCES, UNLESS OTHERWISE NOTED:  
 XX = ± 1/32 ( ) = REFERENCE  
 .XX = ± .030 .XXX = ± .010  
 ANGLE = ± 1'

DO NOT SCALE DRAWING

SCALE 1:6 DRAWN AB APPD LCP MFR SP DATE 10/13/04

**Belshaw**  
 BELSHAW BROTHERS INC., SEATTLE, WASHINGTON

TITLE: DRAIN TRAY / RAIL ASSY

MATERIAL: SEE B.O.M.

SIZE B SHEET 1 OF 1 DRAWING NUMBER TG-1012 REV 2

G:\RELEASED DESIGN\TG-TG-1012.dwg

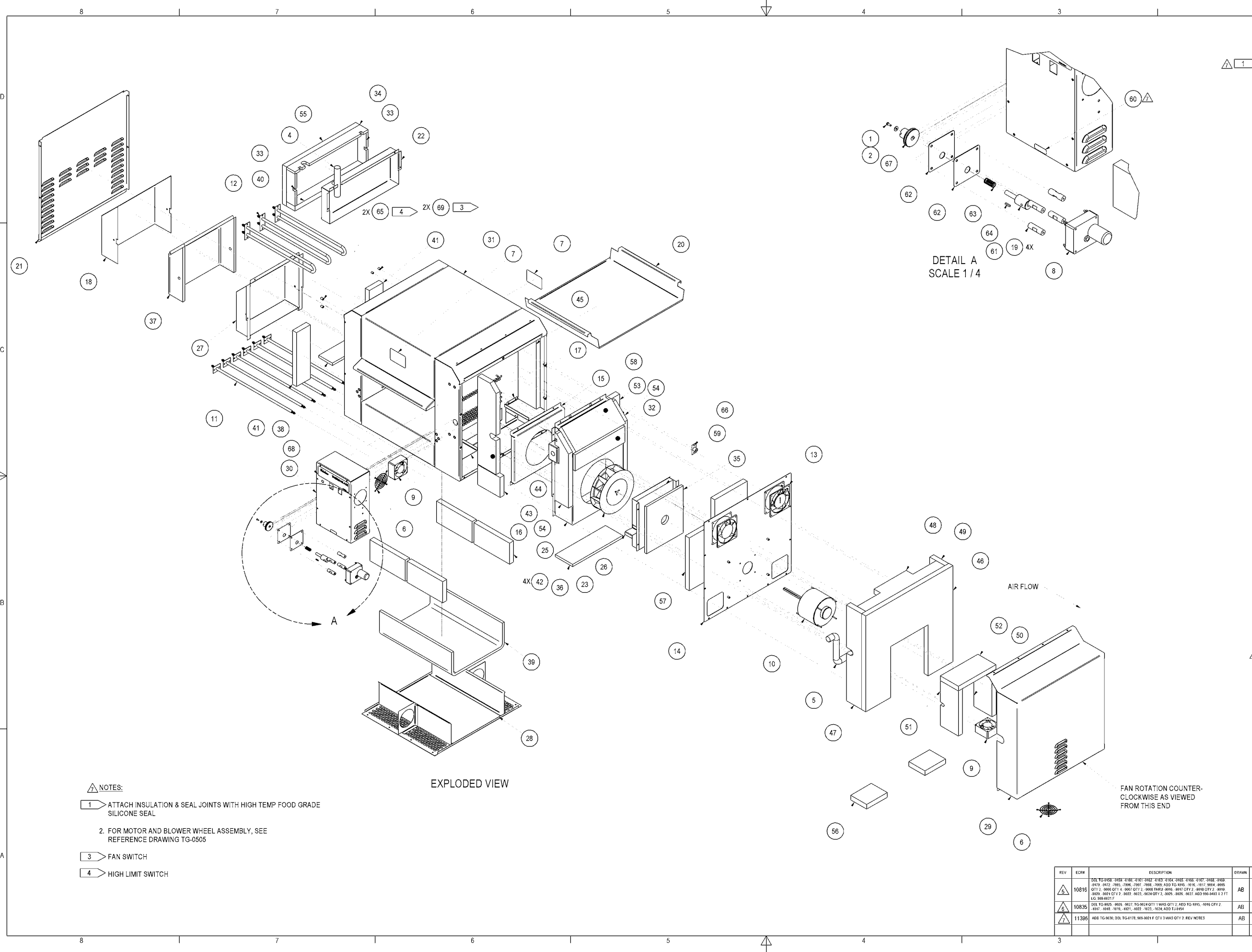

BILL OF MATERIAL			
ITEM	QTY	PART NUMBER	DESCRIPTION
1	1	--	SS SCW ROUND HEAD SLOTTED 6-32 UNC X 0.375
2	1	--	#6 SAE FLAT WASHER SST
3	3	909-0021.F	SEALANT, SIL HI-HEAT
4	1	990-0403	INSULATION 1" I.D. ACRYLIC SLEEVE X 6 LG
5	1	990-0403	INSULATION 1" I.D. ACRYLIC SLEEVE X 18 LG
6	2	ACS-0024	FINGER GUARD FOR 3 1/8" SQ FAN
7	2	MK-0186	LABEL; CAUTION - HOT
8	REF	REF	GEAR MOTOR
9	REF	REF	FAN, AXIAL
10	REF	REF	OVEN MOTOR
11	REF	REF	HEATING ELEMENT
12	REF	REF	HEATING ELEMENT
13	REF	REF	FAN, AXIAL
14	1	TG-0010	MOTOR MOUNTING PLATE
15	1	TG-0080	INLET BAFFLE
16	1	TG-0089	COOLING TUNNEL; BACK-LEFT
17	1	TG-0100	COOLING TUNNEL; BACK-RIGHT
18	1	TG-0103	INSULATION COVER; FRONT
19	4	TG-0114	SPACER; CONVEYOR DRIVE
20	1	TG-0115	DRIP TRAY; OVEN
21	1	TG-0148	FRONT COVER
22	1	TG-0157	ELEMENT COVER
23	1	TG-0183	FAN
24	1	TG-0505	MOTOR ASSY; LAYOUT
25	1	TG-0519	WLDT; HEAT DEFLECTOR
26	1	TG-0521	BLOWER COVER ASSY
27	1	TG-0522	WLDT; RETURN HEAT DUCT
28	1	TG-0523	WLDT; BOTTOM COVER
29	1	TG-0530	WLDT; REAR COVER; RF/LB
30	1	TG-0533	ASSY; CONTROL BOX; WAL-MART
31	1	TG-1000	ASSY; OVEN SHT. METAL RF/LB OPERATE
32	1	TG-1015	INSUL MODIFICATION, HEAT DEFLECTOR, FRT
33	2	TG-1016	INSUL MODIFICATION, ELEMENT COVER, SIDE
34	1	TG-1017	INSUL MODIFICATION, ELEMENT COVER, TOP
35	1	TG-1018	INSUL MOD, BLWR COVER, 1 3/4 HOLE
36	1	TG-1019	INSUL MOD, DEFLECTOR, BOTTOM
37	1	TG-1021	INSUL MODIFICATION, FRONT
38	1	TG-1022	INSUL MODIFICATION, DUCT, BOTTOM
39	1	TG-1023	INSUL MODIFICATION, TUNNEL
40	1	TG-9004	INSUL, ELEMENT COVER, BOTTOM
41	2	TG-9005	INSUL, OUTER ENVEL ASSY, BK
42	4	TG-9006	INSUL, CENTER PANEL, BOTTOM
43	2	TG-9007	INSUL, OUTER ENVEL ASSY, LOWER
44	1	TG-9008	INSUL, OUTER ENVEL ASSY, UPPER
45	1	TG-9009	INSUL, OUTER ENVEL ASSY, UPPER
46	1	TG-9010	INSUL, REAR COVER, BACK
47	1	TG-9011	INSUL, REAR COVER SIDE, RT
48	1	TG-9012	INSUL, REAR COVER, TOP
49	1	TG-9013	INSUL, REAR COVER SIDE, LH
50	1	TG-9014	INSUL, SIDE, MTR COVER
51	1	TG-9015	INSUL, SIDE, W/SLOT, MTR COVER
52	1	TG-9016	INSUL, TOP, MTR COVER
53	2	TG-9017	INSUL, OUTER ENVELOPE ASSY, FRT
54	2	TG-9018	INSUL, HEAT DEFLECTOR, SIDE
55	1	TG-9020	INSUL, ELEMENT COVER, FRONT
56	2	TG-9021	INSUL, REAR COVER, BOTTOM
57	1	TG-9022	INSUL, MOTOR MTG PLATE
58	1	TG-9023	INSUL, HEAT DEFLECTOR, FRT
59	1	TG-9024	INSULATION, BLWR COVER, 5/8 HOLE
60	1	TG-9030	LABEL, CONVEYOR RESET
61	1	TJ-0150	DRIVE ADAPTER
62	2	TJ-0151	CONV. MOTOR ADJUSTING PLATE
63	1	TJ-0153	COMPRESSION SPRING
64	1	TJ-0154	KEY; T <sub>J</sub> ; OVEN
65	2	TJ-0187	STANDOFF, SNAP DISK
66	1	TJ-0534	WELDMENT; THERMOCOUPLE MOUNT
67	1	TNGV-0045	DRIVE COUPLING/PULLEY
68	1	TNGV-0071	LABEL; CONTROL PANEL; THERMOGLAZE
69	2	TZ-17-0021	SPACER 5/16 DIA X 3/8 LG

- NOTES:**
- 1 ATTACH INSULATION & SEAL JOINTS WITH HIGH TEMP FOOD GRADE SILICONE SEAL
  - 2 FOR MOTOR AND BLOWER WHEEL ASSEMBLY, SEE REFERENCE DRAWING TG-0505
  - 3 FAN SWITCH
  - 4 HIGH LIMIT SWITCH

EXPLODED VIEW

FAN ROTATION COUNTER-CLOCKWISE AS VIEWED FROM THIS END

REV	ECR#	DESCRIPTION	DRWN	DATE	APPD	APPR	SCALE	SHEET	TITLE
5	10816	DEL TG-0158, 0159, 0160, 0161, 0162, 0163, 0164, 0165, 0166, 0167, 0168, 0169, 0170, 0171, 0172, 0173, 0174, 0175, 0176, 0177, 0178, 0179, 0180, 0181, 0182, 0183, 0184, 0185, 0186, 0187, 0188, 0189, 0190, 0191, 0192, 0193, 0194, 0195, 0196, 0197, 0198, 0199, 0200, 0201, 0202, 0203, 0204, 0205, 0206, 0207, 0208, 0209, 0210, 0211, 0212, 0213, 0214, 0215, 0216, 0217, 0218, 0219, 0220, 0221, 0222, 0223, 0224, 0225, 0226, 0227, 0228, 0229, 0230, 0231, 0232, 0233, 0234, 0235, 0236, 0237, 0238, 0239, 0240, 0241, 0242, 0243, 0244, 0245, 0246, 0247, 0248, 0249, 0250, 0251, 0252, 0253, 0254, 0255, 0256, 0257, 0258, 0259, 0260, 0261, 0262, 0263, 0264, 0265, 0266, 0267, 0268, 0269, 0270, 0271, 0272, 0273, 0274, 0275, 0276, 0277, 0278, 0279, 0280, 0281, 0282, 0283, 0284, 0285, 0286, 0287, 0288, 0289, 0290, 0291, 0292, 0293, 0294, 0295, 0296, 0297, 0298, 0299, 0300, 0301, 0302, 0303, 0304, 0305, 0306, 0307, 0308, 0309, 0310, 0311, 0312, 0313, 0314, 0315, 0316, 0317, 0318, 0319, 0320, 0321, 0322, 0323, 0324, 0325, 0326, 0327, 0328, 0329, 0330, 0331, 0332, 0333, 0334, 0335, 0336, 0337, 0338, 0339, 0340, 0341, 0342, 0343, 0344, 0345, 0346, 0347, 0348, 0349, 0350, 0351, 0352, 0353, 0354, 0355, 0356, 0357, 0358, 0359, 0360, 0361, 0362, 0363, 0364, 0365, 0366, 0367, 0368, 0369, 0370, 0371, 0372, 0373, 0374, 0375, 0376, 0377, 0378, 0379, 0380, 0381, 0382, 0383, 0384, 0385, 0386, 0387, 0388, 0389, 0390, 0391, 0392, 0393, 0394, 0395, 0396, 0397, 0398, 0399, 0400, 0401, 0402, 0403, 0404, 0405, 0406, 0407, 0408, 0409, 0410, 0411, 0412, 0413, 0414, 0415, 0416, 0417, 0418, 0419, 0420, 0421, 0422, 0423, 0424, 0425, 0426, 0427, 0428, 0429, 0430, 0431, 0432, 0433, 0434, 0435, 0436, 0437, 0438, 0439, 0440, 0441, 0442, 0443, 0444, 0445, 0446, 0447, 0448, 0449, 0450, 0451, 0452, 0453, 0454, 0455, 0456, 0457, 0458, 0459, 0460, 0461, 0462, 0463, 0464, 0465, 0466, 0467, 0468, 0469, 0470, 0471, 0472, 0473, 0474, 0475, 0476, 0477, 0478, 0479, 0480, 0481, 0482, 0483, 0484, 0485, 0486, 0487, 0488, 0489, 0490, 0491, 0492, 0493, 0494, 0495, 0496, 0497, 0498, 0499, 0500, 0501, 0502, 0503, 0504, 0505, 0506, 0507, 0508, 0509, 0510, 0511, 0512, 0513, 0514, 0515, 0516, 0517, 0518, 0519, 0520, 0521, 0522, 0523, 0524, 0525, 0526, 0527, 0528, 0529, 0530, 0531, 0532, 0533, 0534, 0535, 0536, 0537, 0538, 0539, 0540, 0541, 0542, 0543, 0544, 0545, 0546, 0547, 0548, 0549, 0550, 0551, 0552, 0553, 0554, 0555, 0556, 0557, 0558, 0559, 0560, 0561, 0562, 0563, 0564, 0565, 0566, 0567, 0568, 0569, 0570, 0571, 0572, 0573, 0574, 0575, 0576, 0577, 0578, 0579, 0580, 0581, 0582, 0583, 0584, 0585, 0586, 0587, 0588, 0589, 0590, 0591, 0592, 0593, 0594, 0595, 0596, 0597, 0598, 0599, 0600, 0601, 0602, 0603, 0604, 0605, 0606, 0607, 0608, 0609, 0610, 0611, 0612, 0613, 0614, 0615, 0616, 0617, 0618, 0619, 0620, 0621, 0622, 0623, 0624, 0625, 0626, 0627, 0628, 0629, 0630, 0631, 0632, 0633, 0634, 0635, 0636, 0637, 0638, 0639, 0640, 0641, 0642, 0643, 0644, 0645, 0646, 0647, 0648, 0649, 0650, 0651, 0652, 0653, 0654, 0655, 0656, 0657, 0658, 0659, 0660, 0661, 0662, 0663, 0664, 0665, 0666, 0667, 0668, 0669, 0670, 0671, 0672, 0673, 0674, 0675, 0676, 0677, 0678, 0679, 0680, 0681, 0682, 0683, 0684, 0685, 0686, 0687, 0688, 0689, 0690, 0691, 0692, 0693, 0694, 0695, 0696, 0697, 0698, 0699, 0700, 0701, 0702, 0703, 0704, 0705, 0706, 0707, 0708, 0709, 0710, 0711, 0712, 0713, 0714, 0715, 0716, 0717, 0718, 0719, 0720, 0721, 0722, 0723, 0724, 0725, 0726, 0727, 0728, 0729, 0730, 0731, 0732, 0733, 0734, 0735, 0736, 0737, 0738, 0739, 0740, 0741, 0742, 0743, 0744, 0745, 0746, 0747, 0748, 0749, 0750, 0751, 0752, 0753, 0754, 0755, 0756, 0757, 0758, 0759, 0760, 0761, 0762, 0763, 0764, 0765, 0766, 0767, 0768, 0769, 0770, 0771, 0772, 0773, 0774, 0775, 0776, 0777, 0778, 0779, 0780, 0781, 0782, 0783, 0784, 0785, 0786, 0787, 0788, 0789, 0790, 0791, 0792, 0793, 0794, 0795, 0796, 0797, 0798, 0799, 0800, 0801, 0802, 0803, 0804, 0805, 0806, 0807, 0808, 0809, 0810, 0811, 0812, 0813, 0814, 0815, 0816, 0817, 0818, 0819, 0820, 0821, 0822, 0823, 0824, 0825, 0826, 0827, 0828, 0829, 0830, 0831, 0832, 0833, 0834, 0835, 0836, 0837, 0838, 0839, 0840, 0841, 0842, 0843, 0844, 0845, 0846, 0847, 0848, 0849, 0850, 0851, 0852, 0853, 0854, 0855, 0856, 0857, 0858, 0859, 0860, 0861, 0862, 0863, 0864, 0865, 0866, 0867, 0868, 0869, 0870, 0871, 0872, 0873, 0874, 0875, 0876, 0877, 0878, 0879, 0880, 0881, 0882, 0883, 0884, 0885, 0886, 0887, 0888, 0889, 0890, 0891, 0892, 0893, 0894, 0895, 0896, 0897, 0898, 0899, 0900, 0901, 0902, 0903, 0904, 0905, 0906, 0907, 0908, 0909, 0910, 0911, 0912, 0913, 0914, 0915, 0916, 0917, 0918, 0919, 0920, 0921, 0922, 0923, 0924, 0925, 0926, 0927, 0928, 0929, 0930, 0931, 0932, 0933, 0934, 0935, 0936, 0937, 0938, 0939, 0940, 0941, 0942, 0943, 0944, 0945, 0946, 0947, 0948, 0949, 0950, 0951, 0952, 0953, 0954, 0955, 0956, 0957, 0958, 0959, 0960, 0961, 0962, 0963, 0964, 0965, 0966, 0967, 0968, 0969, 0970, 0971, 0972, 0973, 0974, 0975, 0976, 0977, 0978, 0979, 0980, 0981, 0982, 0983, 0984, 0985, 0986, 0987, 0988, 0989, 0990, 0991, 0992, 0993, 0994, 0995, 0996, 0997, 0998, 0999, 1000, 1001, 1002, 1003, 1004, 1005, 1006, 1007, 1008, 1009, 1010, 1011, 1012, 1013, 1014, 1015, 1016, 1017, 1018, 1019, 1020, 1021, 1022, 1023, 1024, 1025, 1026, 1027, 1028, 1029, 1030, 1031, 1032, 1033, 1034, 1035, 1036, 1037, 1038, 1039, 1040, 1041, 1042, 1043, 1044, 1045, 1046, 1047, 1048, 1049, 1050, 1051, 1052, 1053, 1054, 1055, 1056, 1057, 1058, 1059, 1060, 1061, 1062, 1063, 1064, 1065, 1066, 1067, 1068, 1069, 1070, 1071, 1072, 1073, 1074, 1075, 1076, 1077, 1078, 1079, 1080, 1081, 1082, 1083, 1084, 1085, 1086, 1087, 1088, 1089, 1090, 1091, 1092, 1093, 1094, 1095, 1096, 1097, 1098, 1099, 1100, 1101, 1102, 1103, 1104, 1105, 1106, 1107, 1108, 1109, 1110, 1111, 1112, 1113, 1114, 1115, 1116, 1117, 1118, 1119, 1120, 1121, 1122, 1123, 1124, 1125, 1126, 1127, 1128, 1129, 1130, 1131, 1132, 1133, 1134, 1135, 1136, 1137, 1138, 1139, 1140, 1141, 1142, 1143, 1144, 1145, 1146, 1147, 1148, 1149, 1150, 1151, 1152, 1153, 1154, 1155, 1156, 1157, 1158, 1159, 1160, 1161, 1162, 1163, 1164, 1165, 1166, 1167, 1168, 1169, 1170, 1171, 1172, 1173, 1174, 1175, 1176, 1177, 1178, 1179, 1180, 1181, 1182, 1183, 1184, 1185, 1186, 1187, 1188, 1189, 1190, 1191, 1192, 1193, 1194, 1195, 1196, 1197, 1198, 1199, 1200, 1201, 1202, 1203, 1204, 1205, 1206, 1207, 1208, 1209, 1210, 1211, 1212, 1213, 1214, 1215, 1216, 1217, 1218, 1219, 1220, 1221, 1222, 1223, 1224, 1225, 1226, 1227, 1228, 1229, 1230, 1231, 1232, 1233, 1234, 1235, 1236, 1237, 1238, 1239, 1240, 1241, 1242, 1243, 1244, 1245, 1246, 1247, 1248, 1249, 1250, 1251, 1252, 1253, 1254, 1255, 1256, 1257, 1258, 1259, 1260, 1261, 1262, 1263, 1264, 1265, 1266, 1267, 1268, 1269, 1270, 1271, 1272, 1273, 1274, 1275, 1276, 1277, 1278, 1279, 1280, 1281, 1282, 1283, 1284, 1285, 1286, 1287, 1288, 1289, 1290, 1291, 1292, 1293, 1294, 1295, 1296, 1297, 1298, 1299, 1300, 1301, 1302, 1303, 1304, 1305, 1306, 1307, 1308, 1309, 1310, 1311, 1312, 1313, 1314, 1315, 1316, 1317, 1318, 1319, 1320, 1321, 1322, 1323, 1324, 1325, 1326, 1327, 1328, 1329, 1330, 1331, 1332, 1333, 1334, 1335, 1336, 1337, 1338, 1339, 1340, 1341, 1342, 1343, 1344, 1345, 1346, 1347, 1348, 1349, 1350, 1351, 1352, 1353, 1354, 1355, 1356, 1357, 1358, 1359, 1360, 1361, 1362, 1363, 1364, 1365, 1366, 1367, 1368, 1369, 1370, 1371, 1372, 1373, 1374, 1375, 1376, 1377, 1378, 1379, 1380, 1381, 1382, 1383, 1384, 1385, 1386, 1387, 1388, 1389, 1390, 1391, 1392, 1393, 1394, 1395, 1396, 1397, 1398, 1399, 1400, 1401, 1402, 1403, 1404, 1405, 1406, 1407, 1408, 1409, 1410, 1411, 1412, 1413, 1414, 1415, 1416, 1417, 1418, 1419, 1420, 1421, 1422, 1423, 1424, 1425, 1426, 1427, 1428, 1429, 1430, 1431, 1432, 1433, 1434, 1435, 1436, 1437, 1438, 1439, 1440, 1441, 1442, 1443, 1444, 1445, 1446, 1447, 1448, 1449, 1450, 1451, 1452, 1453, 1454, 1455, 1456, 1457, 1458, 1459, 1460, 1461, 1462, 1463, 1464, 1465, 1466, 1467, 1468, 1469, 1470, 1471, 1472, 1473, 1474, 1475, 1476, 1477, 1478, 1479, 1480, 1481, 1482, 1483, 1484, 1485, 1486, 1487, 1488, 1489, 1490, 1491, 1492, 1493, 1494, 1495, 1496, 1497, 1498, 1499, 1500, 1501, 1502, 1503, 1504, 1505, 1506, 1507, 1508, 1509, 1510, 1511, 1512, 1513, 1514, 1515, 1516, 1517, 1518, 1519, 1520, 1521, 1522, 1523, 1524, 1525, 1526, 1527, 1528, 1529, 1530, 1531, 1532, 1533, 1534, 1535, 1536, 1537, 1538, 1539, 1540, 1541, 1542, 1543, 1544, 1545, 1546, 1547, 1548, 1549, 1550, 1551, 1552, 1553, 1554, 1555, 1556, 1557, 1558, 1559, 1560, 1561, 1562, 1563, 1564, 1565, 1566, 1567, 1568, 1569, 1570, 1571, 1572, 1573, 1574, 1575, 1576, 1577, 1578, 1579, 1580, 1581, 1582, 1583, 1584, 1585, 1586, 1587, 1588, 1589, 1590, 1591, 1592, 1593, 1594, 1595, 1596, 1597, 1598, 1599, 1600, 1601, 1602, 1603, 1604, 1605, 1606, 1607, 1608, 1609, 1610, 1611, 1612, 1613, 1614, 1615, 1616, 1617, 1618, 1619, 1620, 1621, 1622, 1623, 1624, 1625, 1626, 1627, 1628, 1629, 1630, 1631, 1632, 1633,							

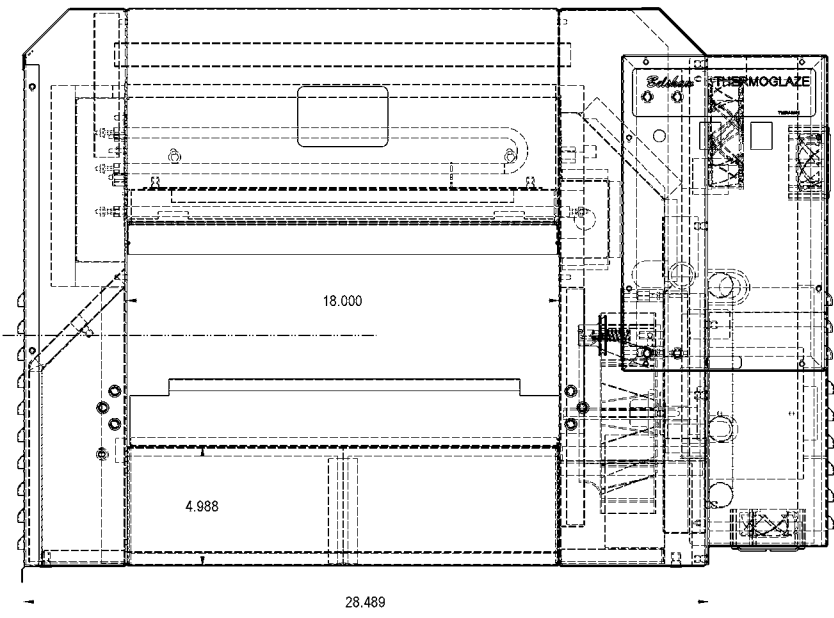
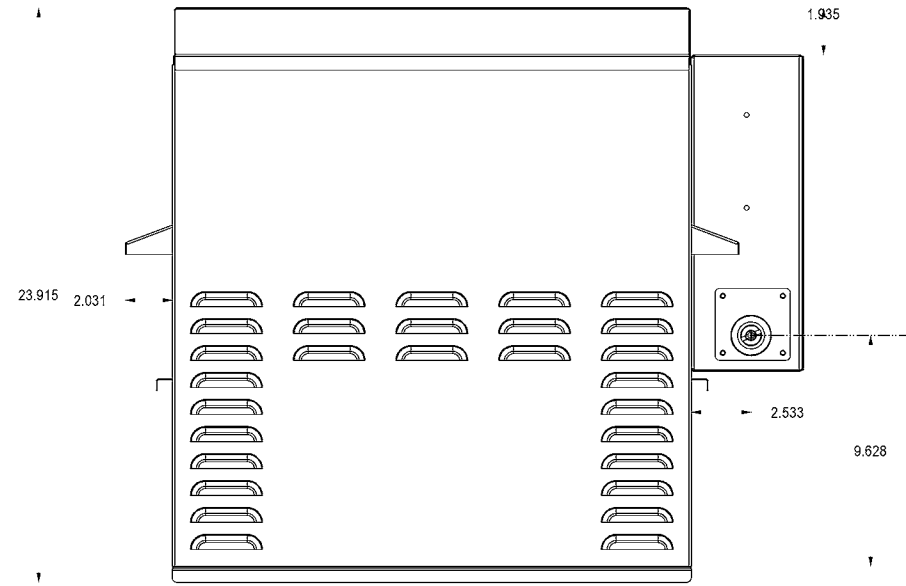
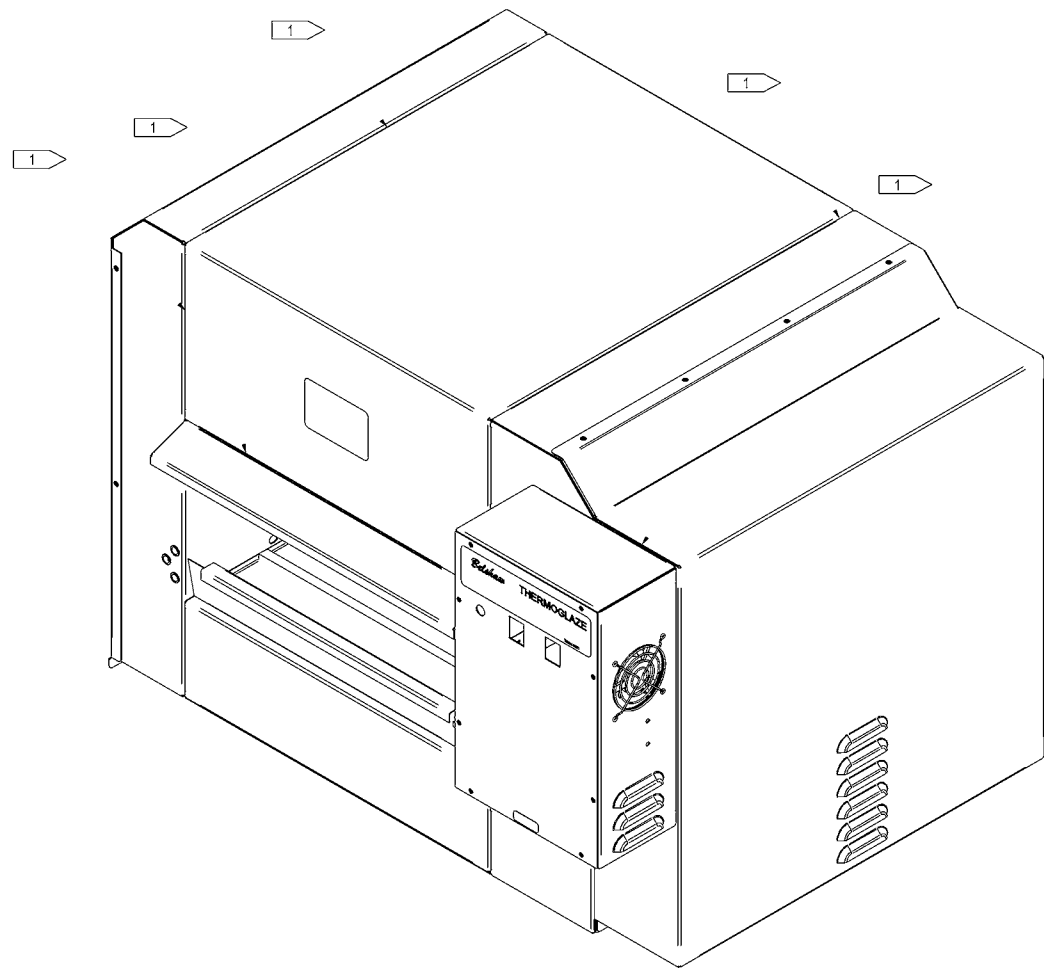
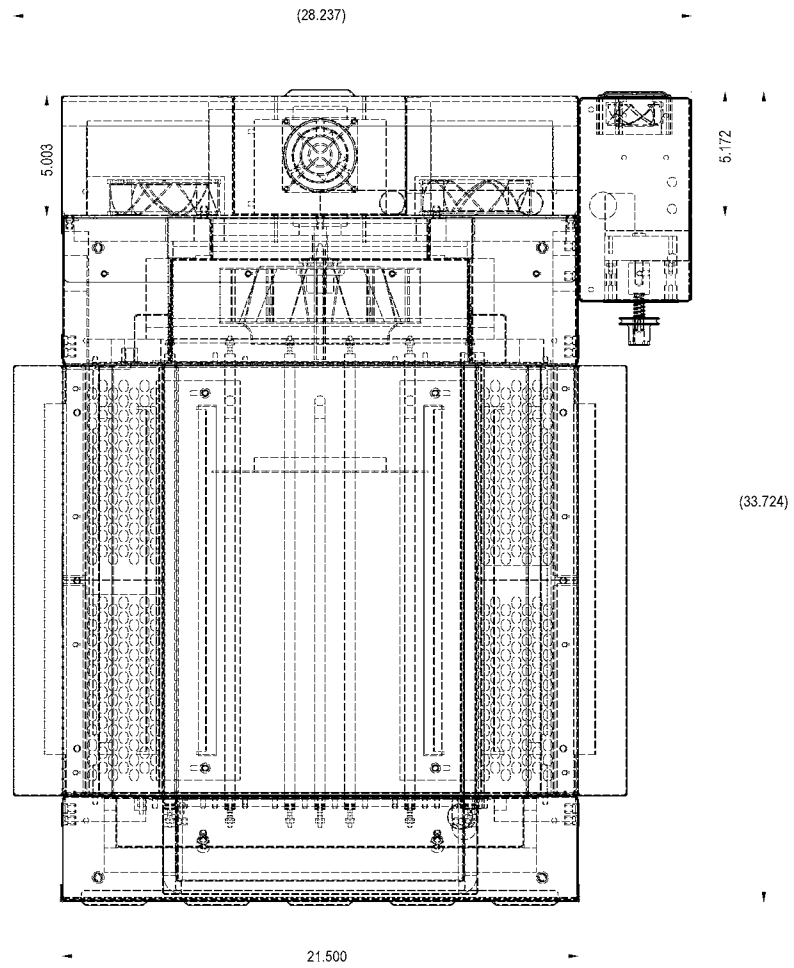

UNLESS OTHERWISE SPECIFIED DIMENSIONS ARE IN INCHES TOLERANCES: UNLESS OTHERWISE NOTED: XX = ± .012 (1) REFERENCE XX = .010 XXX = ± .010 ANGLE = ± 1°		<b>Belshaw</b> BELSHAW BROTHERS INC., SEATTLE, WASHINGTON	
DO NOT SCALE DRAWING		TITLE: ASSY, OVEN, WAL-MART	
SCALE: 1:4	DATE: 5/11/06	MATERIAL: SEE B.O.M.	DRAWING NUMBER: TG-1504
SEE SHEET 1 FOR CURRENT REVISION INFORMATION		SIZE: D	SHEET: 2 of 2
		PROJECT NUMBER: 7	REV: 7

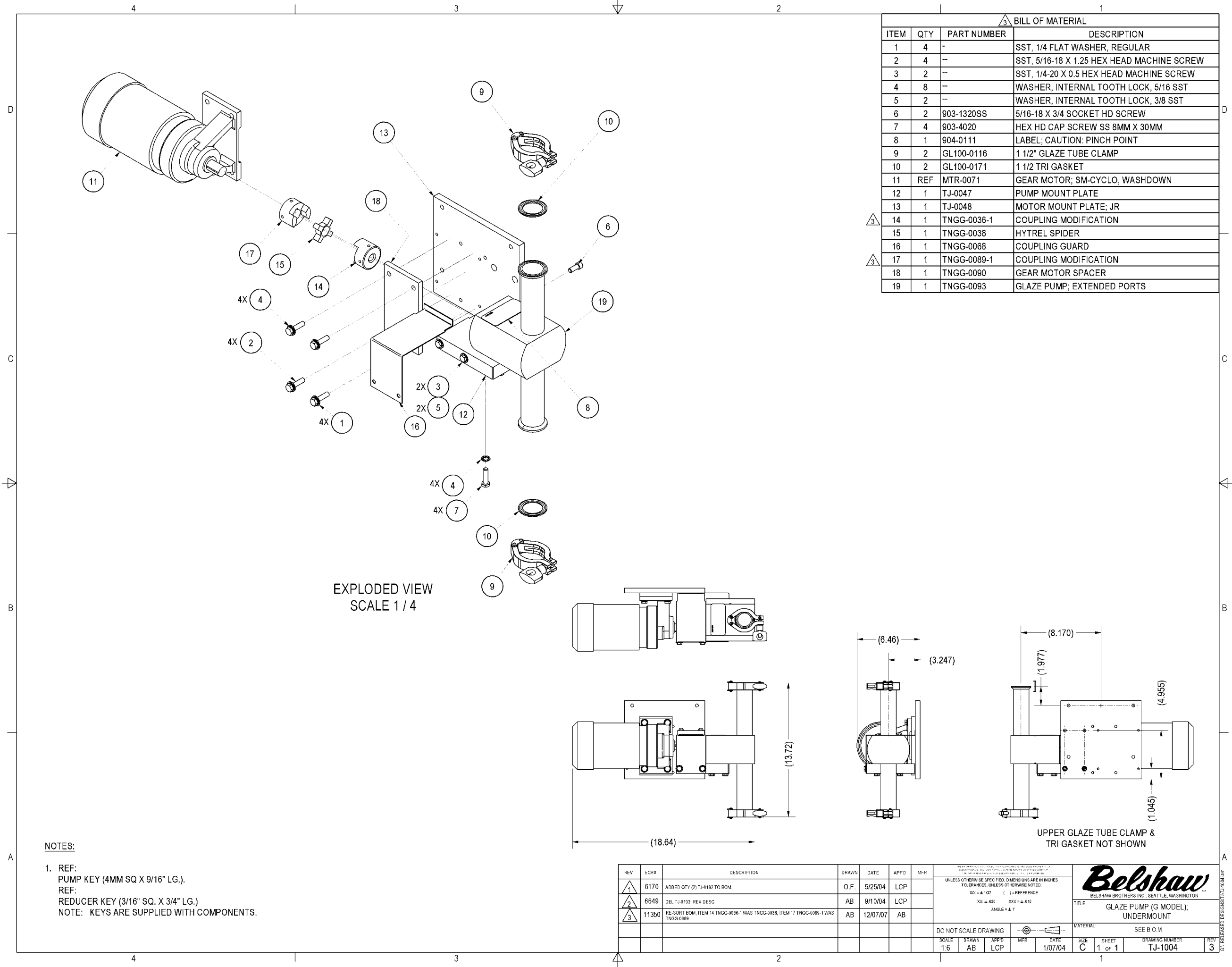

EXPLODED VIEW  
SCALE 1 / 4

BILL OF MATERIAL			
ITEM	QTY	PART NUMBER	DESCRIPTION
1	4	-	SST, 1/4 FLAT WASHER, REGULAR
2	4	--	SST, 5/16-18 X 1.25 HEX HEAD MACHINE SCREW
3	2	--	SST, 1/4-20 X 0.5 HEX HEAD MACHINE SCREW
4	8	--	WASHER, INTERNAL TOOTH LOCK, 5/16 SST
5	2	--	WASHER, INTERNAL TOOTH LOCK, 3/8 SST
6	2	903-1320SS	5/16-18 X 3/4 SOCKET HD SCREW
7	4	903-4020	HEX HD CAP SCREW SS 8MM X 30MM
8	1	904-0111	LABEL; CAUTION: PINCH POINT
9	2	GL100-0116	1 1/2" GLAZE TUBE CLAMP
10	2	GL100-0171	1 1/2 TRI GASKET
11	REF	MTR-0071	GEAR MOTOR; SM-CYCLO, WASHDOWN
12	1	TJ-0047	PUMP MOUNT PLATE
13	1	TJ-0048	MOTOR MOUNT PLATE; JR
14	1	TNGG-0036-1	COUPLING MODIFICATION
15	1	TNGG-0038	HYTREL SPIDER
16	1	TNGG-0068	COUPLING GUARD
17	1	TNGG-0089-1	COUPLING MODIFICATION
18	1	TNGG-0090	GEAR MOTOR SPACER
19	1	TNGG-0093	GLAZE PUMP; EXTENDED PORTS

NOTES:

- 1. REF: PUMP KEY (4MM SQ X 9/16" LG.).
- REF: REDUCER KEY (3/16" SQ. X 3/4" LG.)
- NOTE: KEYS ARE SUPPLIED WITH COMPONENTS.

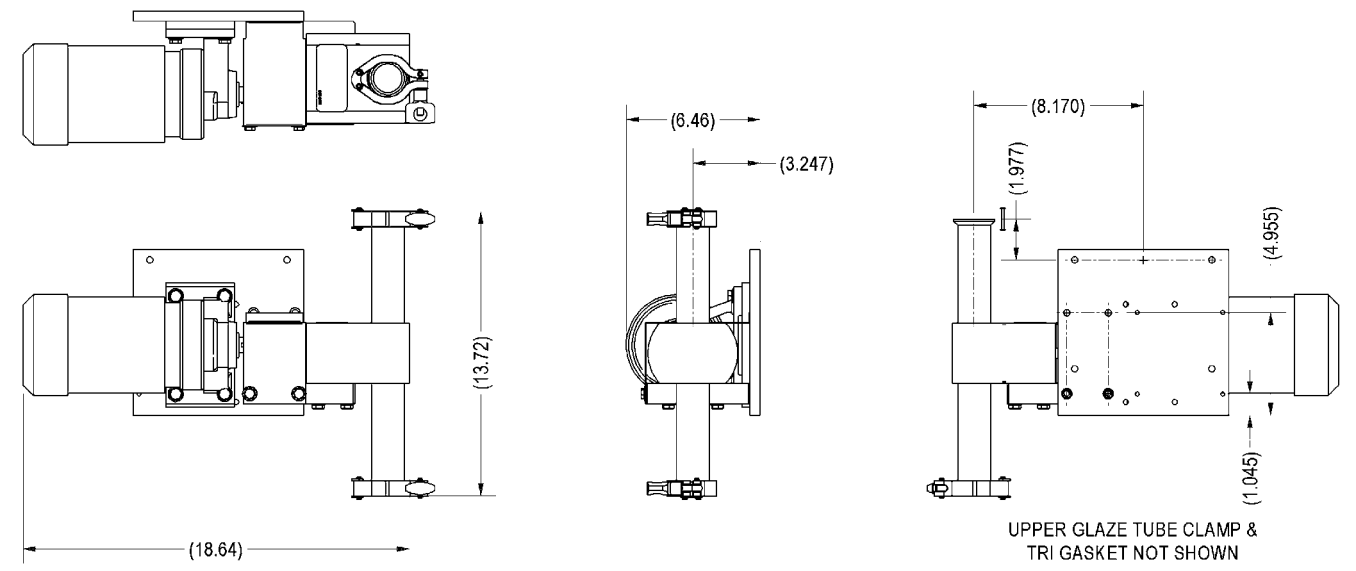

REV	ECR#	DESCRIPTION	DRAWN	DATE	APPD	MFR
1	6170	ADDED QTY (2) T4-0192 TO BOM.	O.F.	5/25/04	LCP	
2	6649	DEL TJ-0192, REV DESC	AB	9/10/04	LCP	
3	11350	RE-SORT BOM; ITEM 14 TNGG-0036-1 WAS TNGG-0038; ITEM 17 TNGG-0089-1 WAS TNGG-0089	AB	12/07/07	AB	

UNLESS OTHERWISE SPECIFIED, DIMENSIONS ARE IN INCHES  
TOLERANCES, UNLESS OTHERWISE NOTED:  
XX ± .102 ( ) = REFERENCE  
XXX ± .003 XXX ± .010  
ANGLE = ± 1°

**Belshaw**  
BELSHAW BROTHERS INC., SEATTLE, WASHINGTON

TITLE: GLAZE PUMP (G MODEL), UNDERMOUNT

DO NOT SCALE DRAWING

MATERIAL: SEE B.O.M.

SCALE	DRAWN	APPD	MFR	DATE	SIZE	SHEET	DRAWING NUMBER	REV
1:6	AB	LCP		1/07/04	C	1 OF 1	TJ-1004	3

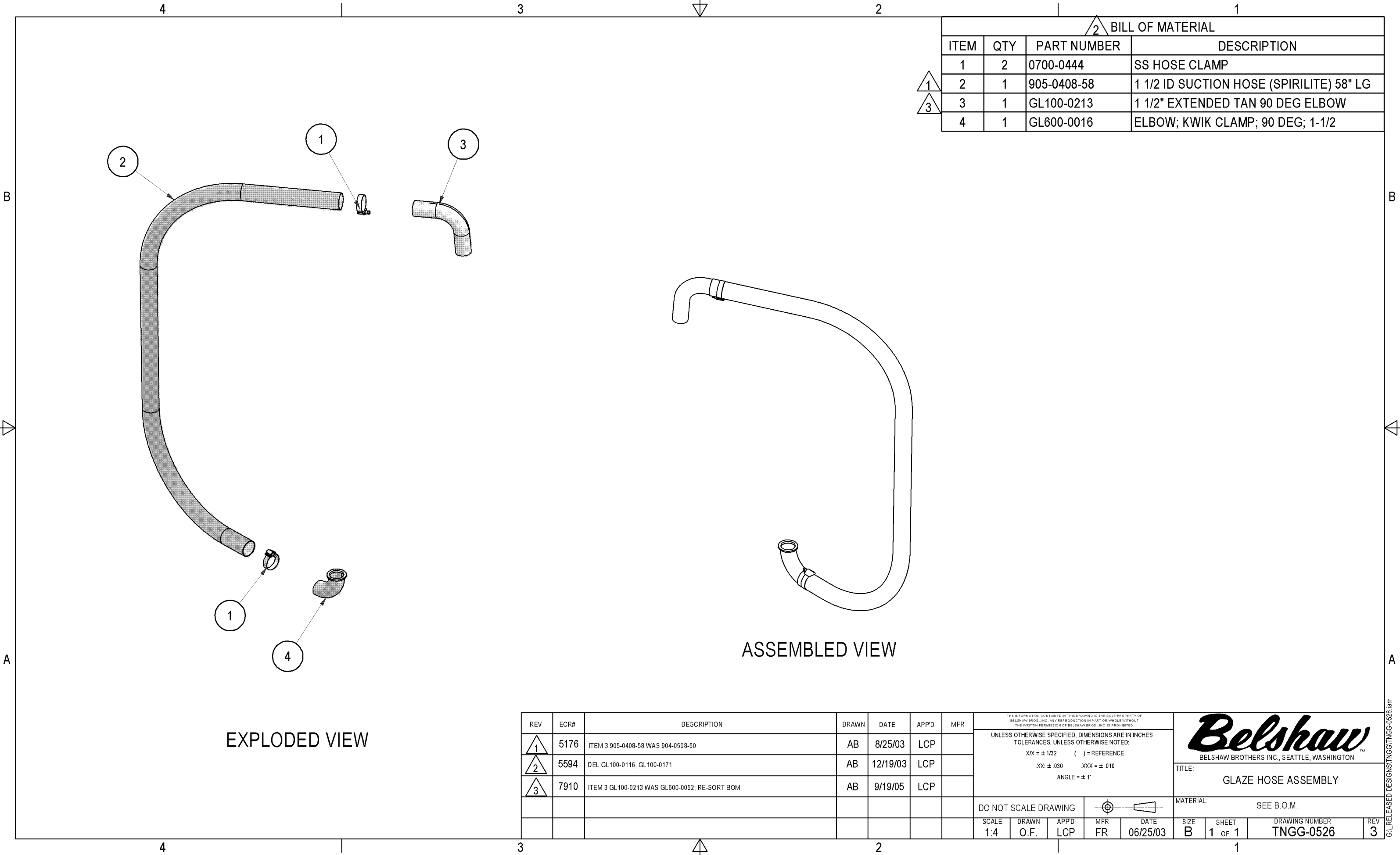

2 BILL OF MATERIAL			
ITEM	QTY	PART NUMBER	DESCRIPTION
1	2	0700-0444	SS HOSE CLAMP
2	1	905-0408-58	1 1/2 ID SUCTION HOSE (SPIRILITE) 58" LG
3	1	GL100-0213	1 1/2" EXTENDED TAN 90 DEG ELBOW
4	1	GL600-0016	ELBOW; KWIK CLAMP; 90 DEG; 1-1/2

EXPLODED VIEW

ASSEMBLED VIEW

REV	ECR#	DESCRIPTION	DRAWN	DATE	APPD	MFR
1	5176	ITEM 3 905-0408-58 WAS 904-0508-50	AB	8/25/03	LCP	
2	5594	DEL GL100-0116, GL100-0171	AB	12/19/03	LCP	
3	7910	ITEM 3 GL100-0213 WAS GL600-0052; RE-SORT BOM	AB	9/19/05	LCP	

THE INFORMATION CONTAINED IN THIS DRAWING IS THE SOLE PROPERTY OF BELSHAW BROS., INC. ANY REPRODUCTION IN PART OR WHOLE WITHOUT THE WRITTEN PERMISSION OF BELSHAW BROS., INC. IS PROHIBITED.

UNLESS OTHERWISE SPECIFIED, DIMENSIONS ARE IN INCHES  
TOLERANCES, UNLESS OTHERWISE NOTED:  
XX = ± 1/32 ( ) = REFERENCE  
.XX = ± .030 .XXX = ± .010  
ANGLE = ± 1'

DO NOT SCALE DRAWING

SCALE 1:4 DRAWN O.F. APPD LCP MFR FR DATE 06/25/03

**Belshaw**  
BELSHAW BROTHERS INC., SEATTLE, WASHINGTON

TITLE: GLAZE HOSE ASSEMBLY

MATERIAL: SEE B.O.M.

SIZE B SHEET 1 OF 1 DRAWING NUMBER TNGG-0526 REV 3

G:\RELEASED DESIGN\TNGG\TNGG-0526.dwg

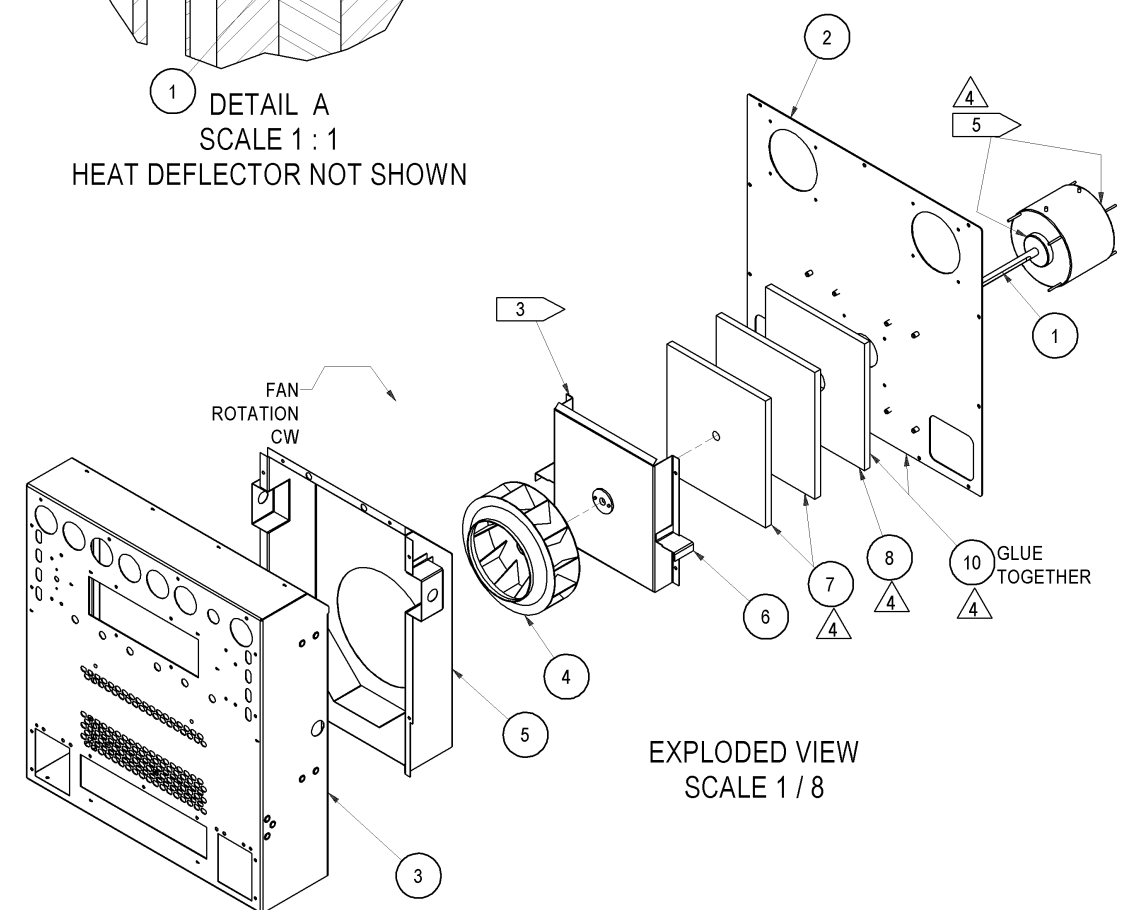
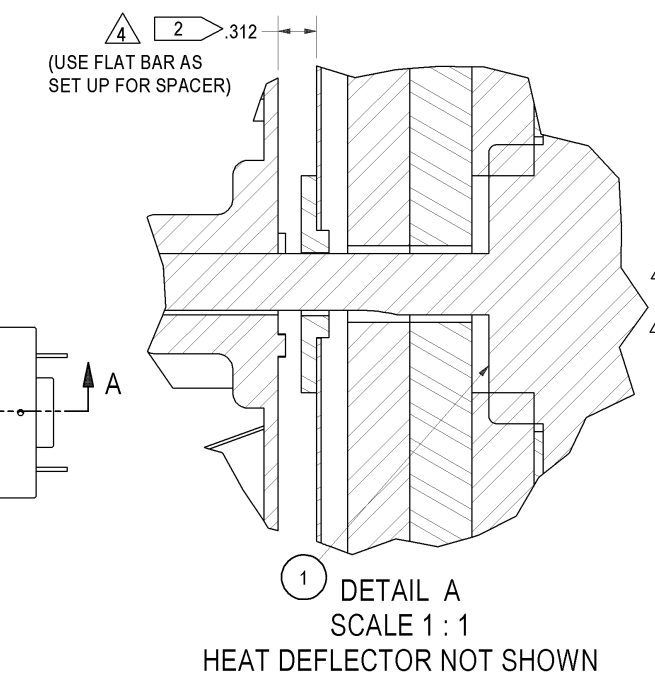
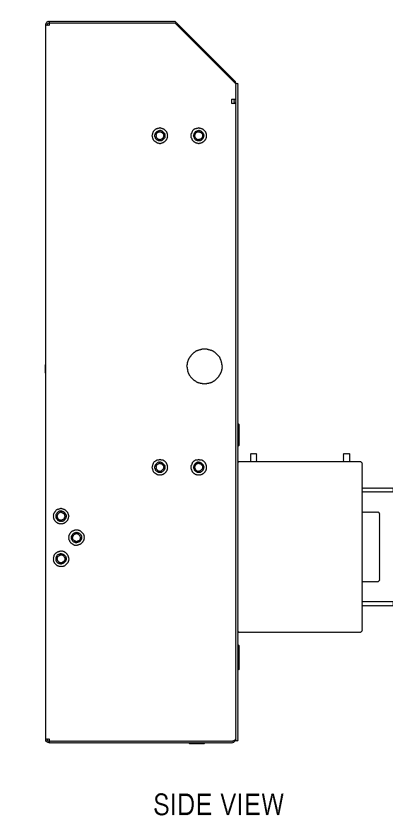
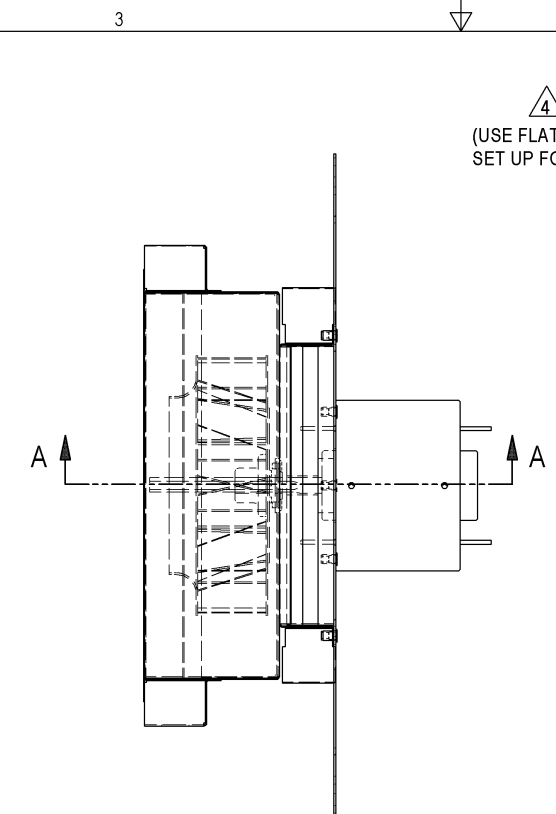
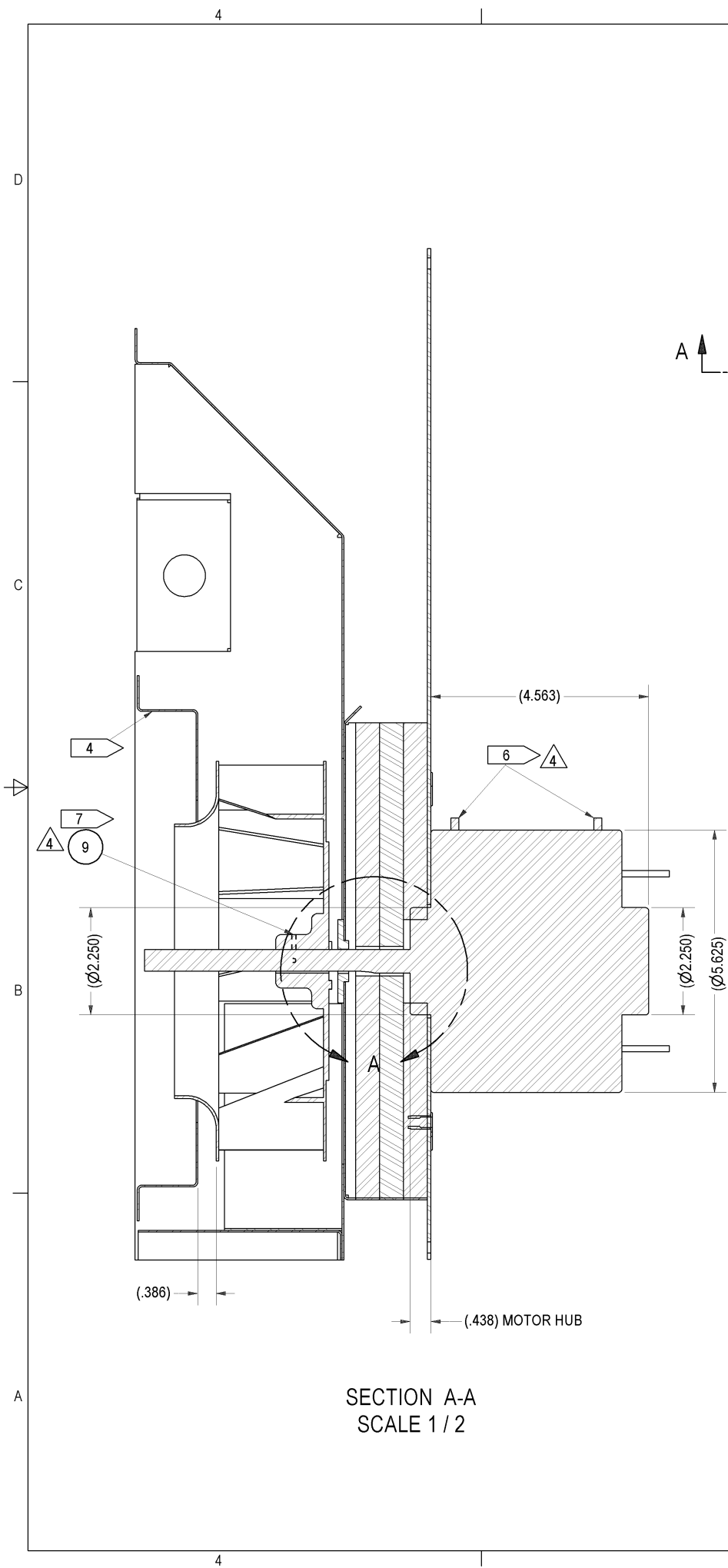

BILL OF MATERIAL				
ITEM	QTY	PART NUMBER	DESCRIPTION	
1	REF	TG-0001	OVEN MOTOR	
2	REF	TG-0010	MOTOR MOUNTING PLATE	
3	REF	TG-0019	OUTER ENVELOPE ASSY; BACK; RF/LB	
4	REF	TG-0183	FAN	
5	REF	TG-0519	WLDT; HEAT DEFLECTOR	
6	REF	TG-0521	BLOWER COVER ASSY	
7	REF	TG-7005	INSULATION, BLWR COVER, 5/8 HOLE	
8	REF	TG-7006	INSULATION, BLWR COVER, 1 3/4 HOLE	
9	REF	905-0481	LOCTITE #294 GREEN (FAN SET SCREWS)	
10	REF	909-0021.F	SEALANT, SIL, HI-HEAT #RTV9732AL (INSULATION)	

- NOTES:**
- 2 DIMENSION WITH MOTOR SHAFT PUSHED IN
  - 3 COVER INSTALLED WITH OPENING AT TOP
  - 4 TG-0080: PART OF OVEN ASSY
  - 5 REMOVE PLASTIC SHAFT SHIELD & RING MOUNTS (BOTH ENDS OF MOTOR)
  - 6 ASSEMBLE MOTOR WITH PLASTIC OIL HOLE PLUGS UP
  - 7 TORQUE & LOCTITE FAN SET SCREWS (108 IN/LBS)

REV	ECR#	DESCRIPTION	DRAWN	DATE	APPD	MFR	UNLESS OTHERWISE SPECIFIED, DIMENSIONS ARE IN INCHES TOLERANCES, UNLESS OTHERWISE NOTED: XX ± .1/32 ( ) = REFERENCE XX ± .030 XXX ± .010 ANGLE ± .1°				MATERIAL: SEE B.O.M.					
1	9057	ADD ISO VIEW; REV VIEW SCALES; RE-SORT BOM, ITEM 6 TG-0171 WAS TG-0007; ADD FLAG NOTES 2, 3, MAKE ALL QTY'S REF	AB	5/01/06	LCP						SEE B.O.M.					
2	9736	UPDATE TG-0001, TG-0521; ITEM 6 TG-0183 WAS TG-0171; ADD, REV DIMS; ADD FAN ROTATION CALL OUT	AB	10/02/06	LCP						SEE B.O.M.					
3	10488	REV FLAG NOTE 2; UPDATE TG-0001; REV DIMS; ADD DETAIL VIEW; ADD TG-0519; RE-SORT BOM	AB	3/22/07	LCP						SEE B.O.M.					
4	10657	ADD TG-7005, TG-7006, 905-0481, 909-0021.F & NOTES 5 THRU 7, REMOVED TG-0002 & TG-0096	WCB	04/25/07	LCP	N/A	DO NOT SCALE DRAWING	SCALE 1.5	DRAWN O.F.	APPD LCP	MFR FR	DATE 10/28/04	SIZE C	SHEET 1 OF 1	DRAWING NUMBER TG-0505	REV 4



G:\RELEASED\DESIGN\TG-0505.DWG

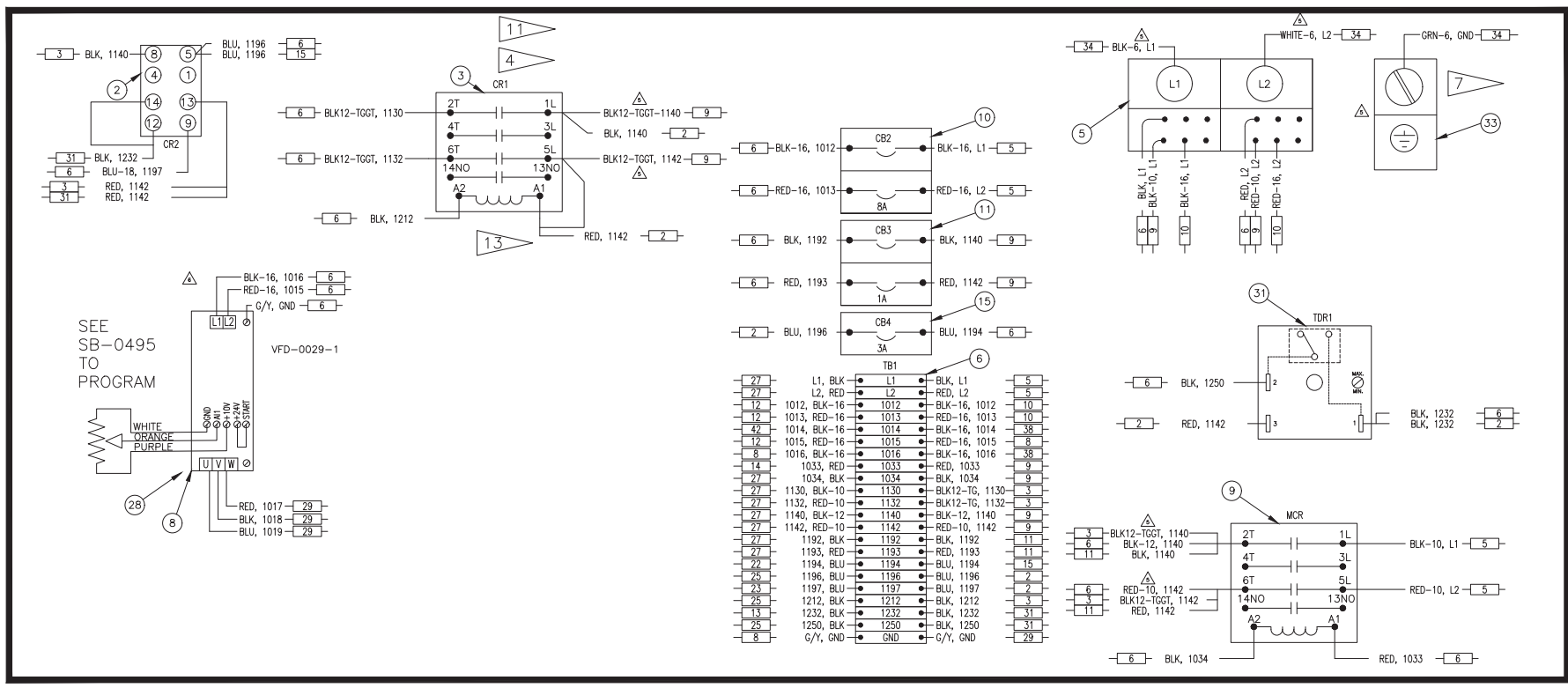
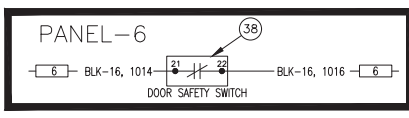

13

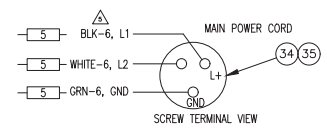
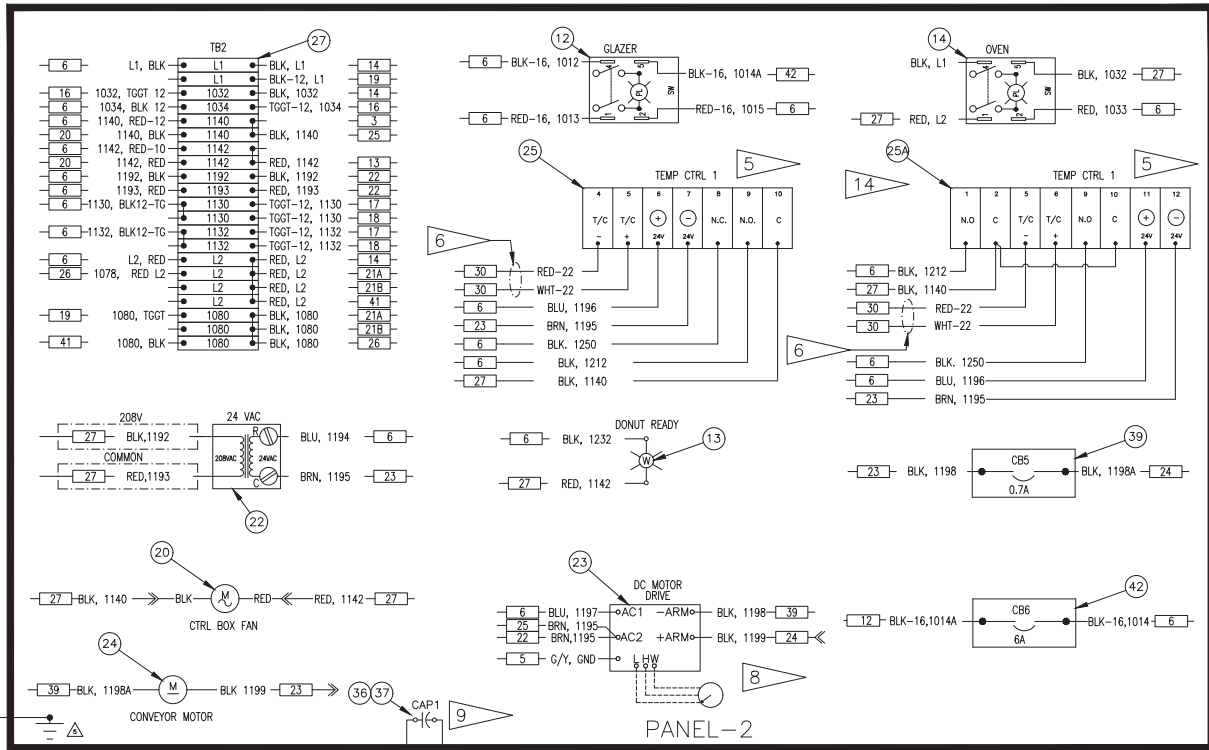

- NOTES:
- UNLESS NOTED, ALL WIRES 18AWG
  - UNLESS NOTED, USE 105°C MACHINE TOOL WIRE
  - DATA TAG VALUES INCLUDE ESTIMATED LOAD FROM THERMOLIZER
  - USE 200" OR 450" WIRE NOT SMALLER THAN AWG-10 BETWEEN RELAY AND ELEMENTS.
  - WIRE DEVICE BY SYMBOLS AT CONTACT LOCATIONS ON DEVICE.
  - COVER STEEL-BRAIDED THERMOCOUPLE WIRE INSIDE PANEL 2 WITH PLASTIC/INSULATING SLEEVE. SECURE WITH WIRE TIES.
  - LABEL WITH GROUND STICKER.
  - SET POTENTIOMETERS ON DC DRIVE AS FOLLOWS:
  - MAXIMUM OUTPUT VOLTAGE SHALL NOT EXCEED 12 VDC. SWITCH OUTPUT LEADS TO REVERSE DIRECTION
  - WRAP CAPACITOR WITH FISHPAPER
  - MOUNT MOTOR WITH OIL HOLE FACING UP.
  - CR1 CHANGED FROM RLY-0012-A TO MDD-0460-C2 EFFECTIVE 3/25/08 SK-1527 AVAILABLE FOR FIELD REPLACEMENT
  - USE WHT-12,450°C WIRE
  - CR1 CHANGED FROM MDD-0460-2C TO #CTR-0059 EFFECTIVE SERIAL # W10050023
  - PANEL HAS 1 OF 2 TEMP CONTROLLERS, 25 OR 25A. USE TERMINAL ID NUMBERS FOR 25A IF CONTROLLER MARKED "OMRON"

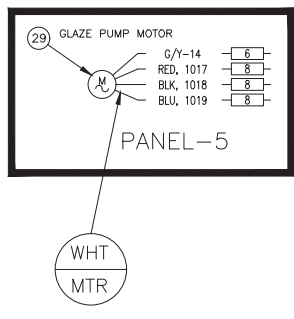
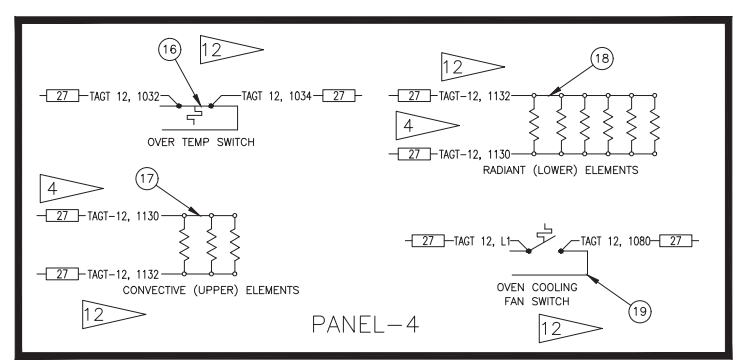
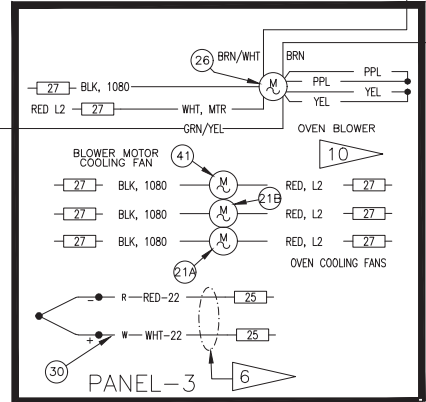

VOLTS	208
PHASE	1
HZ	50/60
AMPS	32.2
KW	6700

ITEM NO.	1709 QTY.	PART NO.	DESCRIPTION
1	--	---	---
2	1	RLY-0008	RELAY 240V AC COIL DPDT 10A/IN
	1	RLY-0008A	BASE, RELAY, FINGERSAFE
	1	RLY-0004B	HOLDDOWN SPRING
3	1	CTR-0059	CTR, 3 POLE, 32A, 220V COIL
4	--	---	---
5	1	TM634-0233	POWER DISTRIBUTION BLOCK WHL
6	A/R	FLOOR STOCK	TERMINALS (AS NEEDED)
7	--	---	---
8	--	---	---
9	1	VFD-0029-1	VFD, 230/1P IN,3P OUT, 1HP (LOVATO)
10	1	624-0144	MAGN CONTACTR 40A 208/600/50/60
11	1	CBR-0012-8	CIRCUIT BREAKER, D8 AMP 2P
12	1	CBR-0012-1	CIRCUIT BREAKER, D1 AMP 2P
13	1	SWT-0022-240	SWITCH, ILLUMINATED ROCKER,DPDT,250V
14	1	PLT-0001	CLEAR NEON PILOT LIGHT, 250V
15	1	SWT-0022-240	SWITCH, ILLUMINATED ROCKER,DPDT,250V
16	1	CBR-0011-3	CIRCUIT BREAKER, D3 AMP 1P
17	3	MKIIG-0110	THERMOSTAT, SNAP DISC, HI TEMP LIMIT
18	6	TG-0022	HEATING ELEMENT; LOWER; 208V, 420W
19	1	FSWT-0001	N.O. SNAP DISC THERMOSTAT, 140°F
20	1	ACF-0003-A	FAN, AXIAL, 230V, 50/60 HZ, 3.125
21	2	EP18/24-0170P	AXIAL FAN, 120/240V, 50/60 HZ
22	1	724G-0037A	XFRMR 38VA, 208/240:24V, 60HZ
23	1	TJ-0158-A	DC MOTOR DRIVE
24	1	TG-9000	GEAR MOTOR, 8.8 RPM, 12VDC
25	1	TJ-0184	DIGITAL TEMP CONTROLLER W/AL AC/DC
25A	1	TJ-0184C-1	OMRON DIGITAL TEMP CONTROLLER W/AL AC/DC
26	1	TG-0001	OVEN MOTOR
27	A/R	FLOOR STOCK	TERMINALS (AS NEEDED)
28	1	POT-1000	POTENTIOMETER, 5K, 2000W
29	1	MTR-0071	GEAR MOTOR; SM-CYCLO, HM-3085
30	1	724G-0144	THERMOCOUPLE
31	1	TDR-0016	TIME DELAY RELAY, 240V INPUT
32	--	---	---
33	1	990-9007	LUG, AL, SET SCREW, 6-300MCM
34	6FT	995-0145	PORTABLE CORD, 6/3, TYPE SOW
35	1	PLG-0039	PIN & SLEEVE, 250V, 60A (360P6W)
36	1	TG-0006	CAPACITOR, 370V
37	1	TG-0006A	CAPACITOR MOUNTING KIT
38	1	#SWT-0036	SWITCH, SAFETY INTERLOCK
39	1	CBR-0024	CIRCUIT BREAKER, 0.7A, PB RESET
40	2	#SWT-0036A	KEY, SWITCH
41	1	ACF-0003-A	FAN, AXIAL, 230V, 50/60HZ, 3.125
42	1	CBR-0029	CBR THER OVERCURRENT,6A

NOTE: TG-1709 208V, 50/60HZ, 1PH PIN & SLEEVE

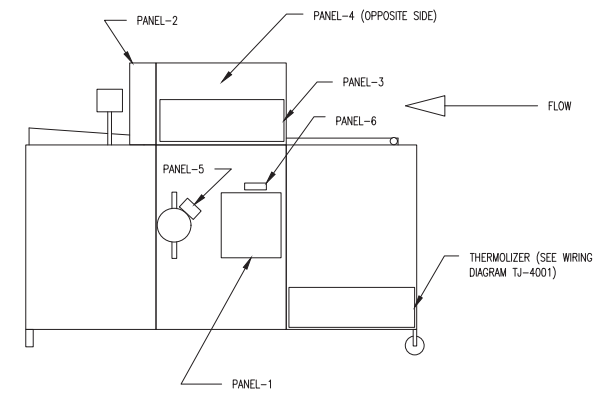

<b>BELSHAW BROS., INC.</b> SEATTLE, WASHINGTON		
TITLE: TG-50 208V, 50/60, 1 PH WM		
DRAWN: T-SMR	PROGRAM: AUTOCAD 2014	DRAWING NO.: TG-4006
APP'D.: JTB	DATE: 01/16/2014	SHEET 2 OF 2
		REV 6



# HEAT & ICE

WAL-MART

Operator's Manual

For

H&I-2, H&I-4

**If you accept the machine from the shipping company, you are, in effect, saying that the machine is in good condition, and you must pay for the machine.** Belshaw cannot pay for shipping damage, because the freight company has accepted the machine from Belshaw in good condition, and is responsible for its safe delivery. **For your protection**, inspect the machine to see that no parts are bent, scratched, or otherwise damaged. If any damage has occurred in shipping, file a freight claim with the shipping company immediately.

To transport the H&I to the workstation and unpack it:

1. Break down the shipping crate.
3. Remove all the packing materials from the H&I, including foam, tape, brown paper, plastic, and white protective coating.

### IMPORTANT

**Keep this manual for future reference.**

## EQUIPMENT RECORD

Please provide the information below when you correspond with us about your machine.

Purchased by \_\_\_\_\_

Installed by \_\_\_\_\_

Date of installation \_\_\_\_\_ Model number \_\_\_\_\_

Serial number \_\_\_\_\_

0609

MN-1731WM

Belshaw Bros., Inc.

814 44<sup>th</sup> Street NW, Suite 103

Auburn, WA 98001 USA

Phone: +-1-206-322-5474 • Fax: +-1-206-322-5425

Toll Free: 1-800-578-2547

Email: [service@belshaw.com](mailto:service@belshaw.com) • <http://www.belshaw-adamatic.com>

# Contents

<b>1</b>	<b>Operation</b>	<b>1</b>
<b>2</b>	<b>Cleaning</b>	<b>2</b>
<b>3</b>	<b>Maintenance</b>	<b>3</b>
<b>4</b>	<b>Trouble Shooting</b>	<b>4</b>
<b>5</b>	<b>Parts Lists &amp; Diagrams</b>	<b>5</b>

# Preface

The H&I Heat and Ice is designed for icing donuts and a variety of baking products quickly and easily.

It is meant to be used on a flat surface. The operator must work safely at all times, read this manual, and follow its instructions and warnings.

The H&I Heat and Ice uses electrical elements to heat water in its kettle. The machine is available with the following electrical configurations:

- 120 volts, 1 phase, 50/60 hertz
- 240 volts, 1 phase, 50/60 hertz

To use the H&I Heat and Ice safely, heed the following warnings:

- Disconnect for power source, before cleaning or repairing.
- Never touch the icing pan once the machine is on. The pan gets very hot, which may cause serious burns.
- Do not overfill the kettle with water.
- Hot water can cause serious burns. Make sure that the system and the water are cool before attempting any adjustment, repair, disassembly, or cleaning.

- To avoid electrocution or other injury, unplug the machine before attempting any adjustment, repair, disassembly, or cleaning.
- To avoid damaging the machine, never use force to assemble, disassemble, operate, clean, or maintain it.
- Be careful never to get water, or other materials on the floor. If anything does get spilled on the floor, mop it up immediately. Materials on the floor can cause people to slip or fall, resulting in serious injury or loss of life.
- To prevent unintentional startup and possible fire, unplug the machine if there is a local power outage. When the power is restored, it is safe to plug the machine in again.
- To avoid electrocution, make sure that all electrical cords are not frayed or cracked and that they do not pass through any water.
- Make sure that all electrical cords are routed so that no one will trip over them.

# Operation

1



Figure 1. H&I-4. (Your model may have thermostat located out of sight)

## WARNING

Do not operate without proper water level.  
This will prevent damage to the heater  
element.

## WARNING

Do not submerge the heating element or  
control box with water.

## Initial setup

1. Remove the Icer from the box, and remove all packing materials.

2. Wash the Icer and bowls with warm water and a mild detergent, then Sanitize.
3. Replace 3 of the icing bowls in the icer. Leave one round hole open.
4. Fill the Icer with water through the opening without a bowl. Fill until the icing bowls begin to float. ALWAYS USE HOT WATER.
5. Install the thermometer through the small hole in the cover.
6. Plug in H&I. Turn on the power switch.
7. Turn the thermostat dial under the icer to its maximum setting. Adjust later for desired icing temperature if necessary.
8. In operation, the water level of the H&I should be in contact as much as possible with the icing bowls. To release water, use the drain. To refill water, use one of the bowl openings. Remember to use HOT water.

## NOTES

Always use hot water to fill the Icer. Cold water takes a long time to heat up to 120°F.

Final setting will vary depending on desired icing temperature

Do not turn the icer off overnight; H&I can take up to 8 hours to reheat

# 2

# Cleaning

For your safety, observe the following warnings throughout the entire cleaning process.

## WARNING

**Thoroughly clean and dry the floor if glaze, water, or other materials are spilled. Materials spilled on the floor can cause serious injury or loss of life.**

## WARNING

**To avoid the possibility of shock, unplug the unit before cleaning.**

Once a day, clean as explained below.

## WARNING

**To avoid being burned, wait for icing pan to cool before removing.**

1. Unplug the unit. Remove any debris from the work area before disassembling the H&I.
2. Remove bowls, lid and thermometer and wash with warm soapy water, rinse and wipe dry.
3. Drain water from kettle, using the drain valve on the back of the machine.

## IMPORTANT

**To avoid damage to the wire / frame use caution when removing and transporting the wire / frame.**

4. Clean the H&I with warm water and mild cleaner.
5. Return the bowls, lids and thermometer to the kettle

## IMPORTANT

**Do not hose down electrical components.**

# Maintenance

3

There is no maintenance required for the H&I-4 other than regular cleaning.

# 4

# Troubleshooting

If you have a problem with your icer that you cannot solve, call your dealer or another qualified technician.

If your dealer cannot help you, please call Belshaw Bros. at (206) 322-5474. When you call, please specify the following:

- The model name of the machine.
- The serial number of the machine.
- The voltages, phase, and cycle of the machine.

## CAUTION

**If you perform repairs yourself or have them performed by anyone other than a service technician authorized by Belshaw Bros., you do so at your own risk.**

## WARNING

**Disconnect the machine from the power source before disassembling, repairing, or wiring.**

# 5

# Parts Lists & Diagrams

Following are diagrams that make-up the Heat and Ice, Model H&I-4. You can use the parts list and assembly drawing to order replacement parts.

When ordering replacement parts, please provide electrical information about your equipment. Some of the part numbers vary according to the voltage, phase, and cycle of the machine.

Enclosed drawing numbers:

84900124 Bill of Materials

[H&I-4-1002](#) Tub Assembly

H&I-4001 Wiring Diagram

# Parts List Drawing Insert Page

**Title:** Icing Table

**Model:** H&I

**Item Number:** 84900124 H&I-4-208/240,50/60,1-D-BL

**Final Assembly Drawing:** 84900124 Assembly BOM Only

**Sub-Assemblies:** [H&I-4-1002](#) Tub Assembly

**Wiring Diagram:** H&I-4001 Electrical Assembly Drawing (H&I-1701)

# BILL OF MATERIAL

---

PART NUMBER 84900124 R02 H&I-4

Quantity	Component Part	Component Name
1	<a href="#">AMD-0012</a>	THERMOMETER 0-220 LO TEMP TAYLOR
1	H&I-2-0007	TS,LABEL
1	<a href="#">H&amp;I-4-0007</a> R08	COVER,4 STATION
1	H&I-4-0506	LABEL KIT
1	H&I-4-1301P	FRAME ASSEMBLY
1	<a href="#">H&amp;I-4-1302P</a>	WATER TUB ASSEMBLY
4	<a href="#">966-0010.A</a>	BOWL,8 QT MIXING SS
4	<a href="#">966-0011</a>	12" ALUM LID FOR 8QT BOWL ALEGACY
9	<a href="#">903-5102</a>	NUT,HEX,10-24 SS

ITEM NO.	QTY.	PART NO.	DESCRIPTION
		H&I-4-1002	
1	1	H&I-4-0500	WATER TANK ASSEMBLY
2	1	H&I-4-0026	20X16X 2" THK INSULATION
3	1	H&I-6-0027	ELEMENT COVER - INSIDE
4	REF	H&I-6-0521/-0521-240	HEATING ELEMENT ASSEMBLY
5	19	905-0790 x .50	10-24 x 1/2 WELD STUD SS
6	2	905-0790 x .75	10-24 x 3/4 WELD STUD SS
7	1	H&I-4-0023	CAPILLARY HOLDER
8	9	903-5102	#10-24 SS HEX NUT
9	9	903-7513	#10 SS FLAT WASHER
10	16	903-5104.A	10-24 ACORN NUT, SHEET METAL WITH FLANGE
11	1	H&I-2-0003	ELEMENT COVER, EXTERIOR
12	1	H&I-2-0005	CONTROL BOX, 120V
13	1	990-0700	CHASE NIPPLE
14	1	990-0600	LOCK NUT, .500in.

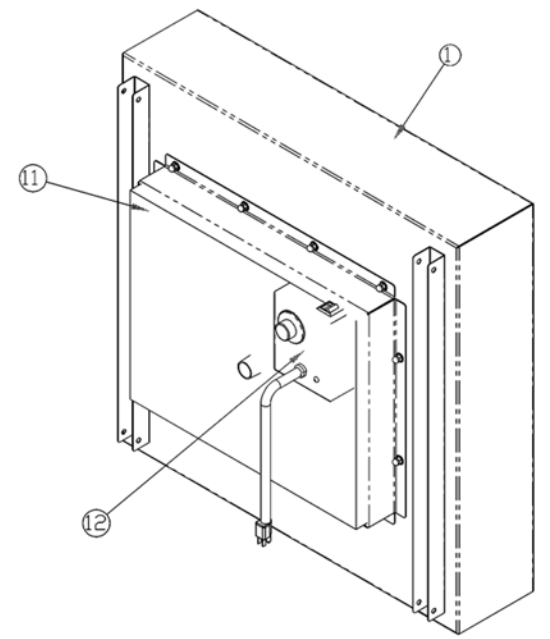
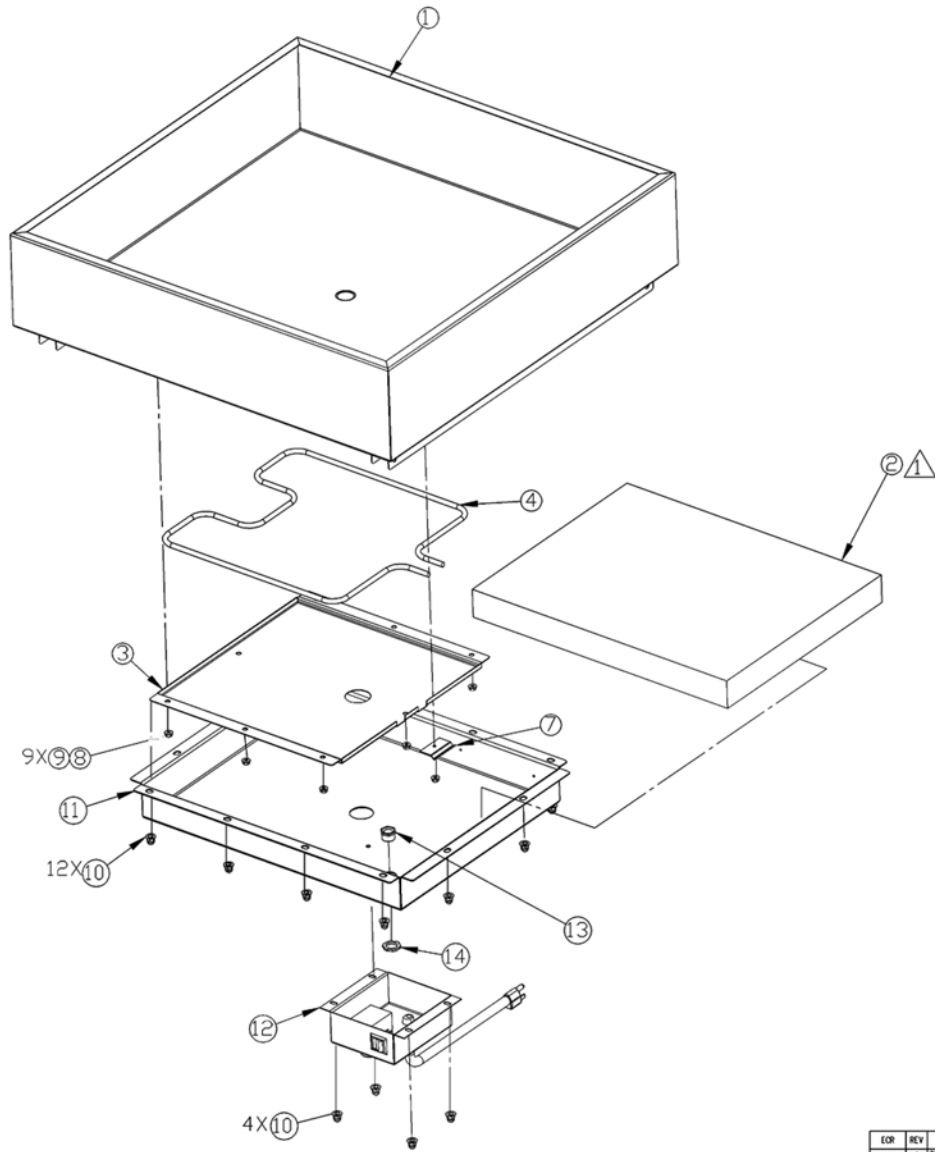

ECR	REV	REVISION	DRAWN	DATE	APP'D	MG
7344	Δ	DEL COL 2, 905-0047, H&I-6-0028 ADD H&I-4-0026; H&I-6-0521 QTY (2) ADD: 120V TO DESCRIPTION	O.F.	5/5/05	LCP	
7397	Δ	DEL H&I-2-0503 ADD H&I-2-0005; MODIFY ITEM # 4 P/L	O.F.	5/19/05	LCP	

UNLESS OTHERWISE SPECIFIED  
DIMENSIONS ARE IN INCHES  
FRACTIONS DECIMALS ANGLES  
± 1/32 ± .010 ± .1°

SCALE: N/A DO NOT SCALE DWG

SHEET 1 OF 1 DRAWN WB APP'D WB DATE 10/27/05 SIZE C DWG. NO: H&I-4-1002 REV 3

BELSHAW BROTHERS., INC.  
SEATTLE, WASHINGTON  
TITLE: TUB ASSEMBLY; Δ Δ  
MATERIAL: SEE B.I.M.

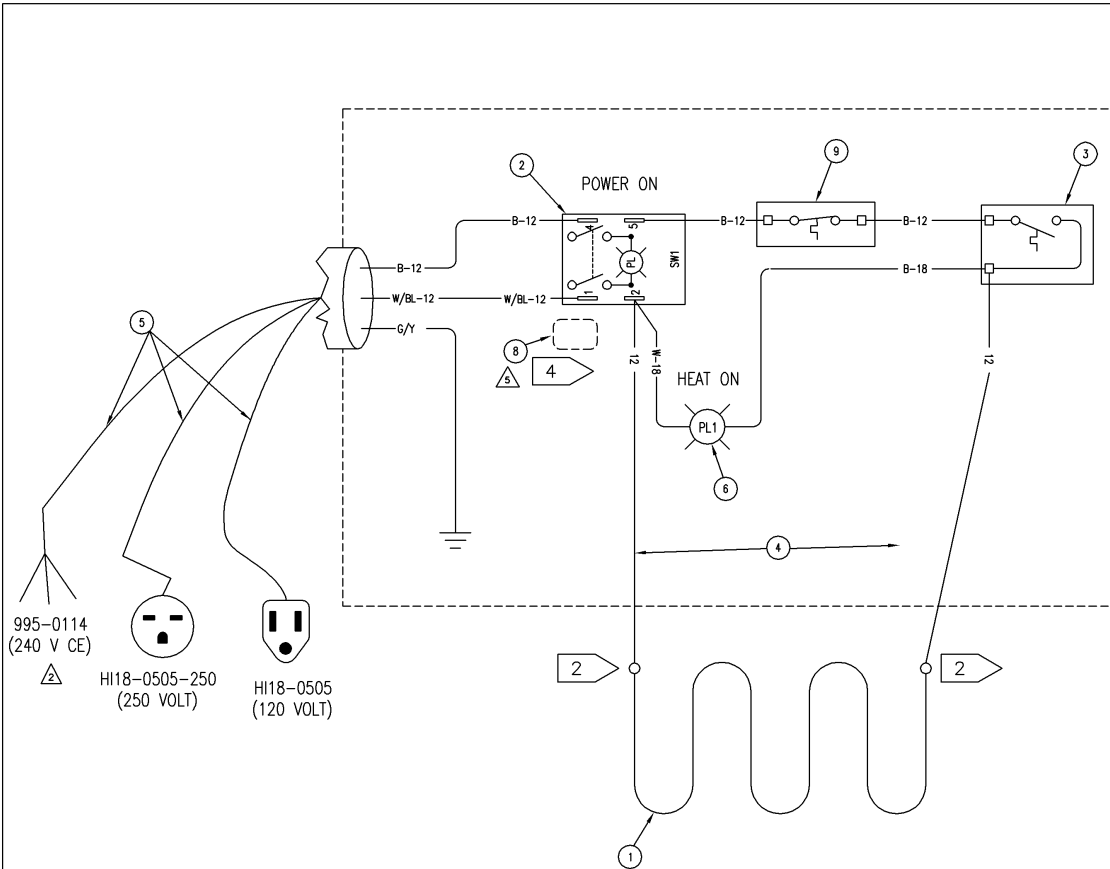

- 995-0114 (240 V CE)
- H118-0505-250 (250 VOLT)
- H118-0505 (120 VOLT)

**DATA TAG**

VOLTS	115/120/208/240
HERTZ	50/60
PHASE	1
AMPS	14.4/15/6.5/7.5
KW	1.7/1.8/1.35/1.8

		H&I-2&4			H&I-6			BOM H&I-1700, -1701, 1702, 1703, 1704 & 1705	
		1700	1701	1704	1702	1703	1705		
		120V	240V	240CE	120V	240V	240CE		
ITEM	QTY	QTY	QTY	QTY	QTY	QTY	PART NO.		DESCRIPTION
1	1		1		1	1	H&I-6-0521		HEATER ELEMENT, 1800W, 120V
		1					H&I-6-0521-240		HEATER ELEMENT, 1800W, 240V
2	1			1			SWT-0022		SWITCH, ROCKER, DPST, ILL., 125V
		1	1		1	1	SWT-0022-240		SWITCH, ROCKER, DPST, ILL., 240V
3	1	1	1	1	1	1	EP18/24-0116		THERMOSTAT
	1	1	1				EP18/24-0116A		KNOB
				1	1	1	EP18/24-0116B		KNOB
4	1	1	1	1	1	1	995-0245		WIRE, HI TEMP, 12 GA
	1			1			H118-0505		POWER CORD, 125V
5		1			1		H118-0505-250		POWER CORD, 250V
			1			1	995-0114		6.0 QMM H07RN F5 PORT CORD
6	1			1			PLT-0002		PILOT LIGHT, 125V, WHITE
		1	1		1	1	PLT-0001		PILOT LIGHT, 250V, WHITE
7	1			1			905-0615		STRAIN RELIEF
		1	1		1	1	905-0616		STRAIN RELIEF
8	1	1	1	1	1	1	FM200-0105		LABEL; ON/OFF
9	1	1	1	1	1	1	DPC-0130-0225		SNAP DISK THERMOSTAT

**NOTES:**

- 1 TURN DIAL 270° (3/4 TURN) FROM OFF POSITION FOR ICING TEMPERATURE OF 110° F. (THERMOSTAT SETTING OF 120°)
- 2 DRILL HOLE THROUGH ELEMENT TERMINALS, AND USE HI-TEMP RING TERMINALS.
- 3 SERIAL NUMBERS:  
H&I-4: W101-108 USE H&I-4-4000 REV 1  
W101-108 USE H&I-4-0001 OR H&I-4-0001-240 ELEMENTS  
H&I-2: W101-ON  
H&I-4: W109-ON  
H&I-6: W101-ON
- 4 PLACE LABEL BENEATH ON/OFF SWITCH, ORIENTED FOR PROPER OPERATION.

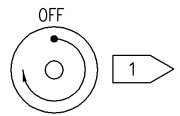

REVISION/DATE	APP'D.
△ ECR 7254: REVISED DATA TAG 4/5/05	BGS
△ ECR 7325: ADDED 1704 & 1705 BOMS 5/3/05	ML
△ ECR 7342: P/N WAS H&I-6-0001-240 5/5/05	ML
△ ECR 7403: ADD ITEM 7, REV. BOM STRUCTURE 5/20/05	LCP
△ ECR 7927: ADD ON/OFF LABEL BW 9/9/05	MJL
△ ECR 11119: ADD ITEM 9 (DPC-0130-0225) JD 9/5/07	JD

**BELSHAW BROS., INC.**  
SEATTLE, WASHINGTON

W/D - H&I-2, 4, 6, ICING TABLE

TITLE: 115/120/208/240V/240VCE, 50/60HZ, 1PH

DRAWN: DAK	SERIAL NO. 3	DRAWING NO.: H&I-4001
APP'D.: DAK	DATE: 12/16/03	SHEET 1 OF 1

## Belshaw Adamatic Bakery Group Limited Warranty / Return Policy

---

Subject to the terms and limitations set forth in this limited warranty ("Limited Warranty"), Belshaw Adamatic Bakery Group (also referred to as "the Manufacturer") warrants to the original purchaser ("Purchaser") of Manufacturer's equipment and parts ("Products"), Belshaw Adamatic Bakery Group's manufacture and assembly of Products to be free from defects in workmanship and material which would result in product failure under normal use and service. Belshaw Adamatic Bakery Group's entire liability under this Limited Warranty is limited to either repairing or replacing at Manufacturer's factory or on Purchaser's premises, at Belshaw Adamatic Bakery Group's option, any Products purchased by Purchaser which shall be determined by the Manufacturer to be defective. If necessary to return Products to Manufacturer's factory, Products must be shipped by Purchaser with transportation charges prepaid by Purchaser.

Belshaw Adamatic Bakery Group reserves the right to make changes in design or add any improvement to its Products at any time without incurring any obligations to install the same on Products previously sold.

Possession, use or operation of Products sold hereunder for any other than their designed purpose, or use of Products which are in poor repair, modified, improperly operated, or neglected, is done at the Purchaser's risk. Belshaw Adamatic Bakery Group hereby disclaims any liability for these actions and shall not be liable for defects in or for any damages or loss to any property which is attributable to such actions.

**Under no circumstances shall Belshaw Adamatic Bakery Group be liable for any indirect, special, incidental, or consequential damages arising out of, or from the use of its Products by Purchaser, its assignees, employees, agents or customers.**

**THIS LIMITED WARRANTY SHALL BE PURCHASER'S SOLE AND EXCLUSIVE REMEDY WITH RESPECT TO DEFECTIVE PRODUCTS.**

### **Warranty Period**

This Limited Warranty covers Products manufactured by Belshaw Adamatic Bakery Group and sold by Belshaw Adamatic Bakery Group or its authorized distributor ("Distributor") or authorized dealer ("Dealer"), and this Limited Warranty shall extend for a period of one (1) year from date of shipment to Purchaser, and to the original Purchaser only.

### **Limited Warranty**

With respect to products not manufactured by Belshaw Adamatic Bakery Group, warranty coverage shall be limited to the warranty of the original manufacturer of the product, or the Belshaw Adamatic Bakery Group Limited Warranty, whichever is the lesser coverage period.

Replacement Products provided under the terms of this Limited Warranty are warranted for the remainder of the original warranty period applicable to the Product.

### **Exclusions**

This Limited Warranty excludes from its coverage and does not apply to: (a) solenoid and relay coils; (b) lamps; (c) "O" rings; (d) belts; and (e) impellers. This Limited Warranty also excludes the cost of labor for removing and replacing Products subject to a warranty claim, other than the labor incurred directly by the Manufacturer when, in Belshaw Adamatic Bakery Group's opinion, a repair of the Product by the Manufacturer is justified.

## Warranty Claims

In case of warranty claims relating to your Product, you must follow the instructions below.

### Report Claims to Your Authorized Distributor or Dealer or to Belshaw Adamatic Bakery Group

As soon as you discover a problem, contact the Distributor or Dealer from whom you purchased the Product or Belshaw Adamatic Bakery Group. Your Distributor or Dealer will notify Belshaw Adamatic Bakery Group for you. **Only Belshaw Adamatic Customer Service can approve or authorize warranty claims.**

You must state the following:

1. Your name, company name, and telephone number
2. The location, phone number, and contact name where the Product is located
3. The invoice number and date of purchase of the Product
4. The Model and Serial Number of the Product, as written on the data tag attached to the Product
5. A description of the problem and how it occurred

### Shipping Damage and Missing Items

**Damage to the Packaging or Crate.** On delivery, promptly check all packages thoroughly for any sign of damage. In cases of visible damage, **always note the damage on the Delivery Receipt.** Failure to note damage is taken by the Freight Carrier to mean that the package is in good condition at time of receipt, and can result in denial of a Freight Claim. Take photographs that clearly show the damage.

**Damage to Products.** If you find any damaged Product inside the shipment, photograph the damage both inside and outside of the package. Do not throw the packaging away. Photos of the package and contents are needed to show the condition of the Product at the time it was received.

**Missing Items.** As soon as you believe any items to be missing from a shipment, promptly report this to the Distributor or Dealer from whom the Product was purchased or to Belshaw Adamatic Bakery Group. If possible, photograph the entire contents of the delivery and email this to your Distributor or Dealer, or to Belshaw Adamatic Customer Service at [service@belshaw.com](mailto:service@belshaw.com).

### Returning Products to Belshaw Adamatic Bakery Group

Under the terms of the Limited Warranty, you may be asked to return to Belshaw Adamatic Bakery Group any Product that is the subject of a warranty claim. These Products must be clearly labeled with a Return Goods Authorization Number ("RGA Number") given to you by your Distributor or Dealer, or by Belshaw Adamatic Customer Service. Products received without an RGA Number will not be processed. All Products must be shipped freight prepaid by the Purchaser to Belshaw Adamatic Bakery Group at the address below.

### Contacting Belshaw Adamatic Bakery Group

At any time, you can contact Belshaw Adamatic Bakery Group customer service for assistance

Belshaw Adamatic Bakery Group Customer Service

814 44th St. NW, Suite 103,

Auburn WA 98001, USA

Phone: 800-578-2547 (USA/ Canada) or (+1)206-322-5474 (Worldwide)

Email: [service@belshaw.com](mailto:service@belshaw.com)

Office Hours: Monday – Friday, 6am to 4pm, USA Pacific Time



**Quality bakery equipment for over 95 years**

**For Service and Support call: 800-578-2547 (USA-Canada)  
or (+1) 206-322-5474 (Worldwide), or contact [service@belshaw.com](mailto:service@belshaw.com)  
[www.belshaw-adamatic.com](http://www.belshaw-adamatic.com) • [www.belshaw.com](http://www.belshaw.com) • [www.adamatic.com](http://www.adamatic.com)**