



Donut Robot®
Mark II-Gas

Operator's Manual

Belshaw Bros., Inc.
814 44TH ST NW Suite 103
Auburn, WA 98001
Phone: 1-206-322-5474 • Fax: 1-206-322-5425
Email: service@belshaw.com • <http://www.belshaw.com>

If you accept the machine from the shipping company, you are, in effect, saying that the machine is in good condition, and you must pay for the machine. Belshaw cannot pay for shipping damage, because the freight company has accepted the machine from Belshaw in good condition, and is responsible for its safe delivery. **For your protection,** inspect the machine to see that no parts are bent, scratched, or otherwise damaged. If any damage has occurred in shipping, file a freight claim with the shipping company immediately.

To unpack the Donut Robot® Mark II-Gas and transport it to the workstation requires two people:

1. Remove the foam and other packing materials from the two boxes.
2. Carry the hopper, plunger, and swing column to the work station.
3. Coil the cutter head power cord and carry the cutter head to the work station.
4. Carry the conveyor assembly the work station.
5. Move the fryer to the workstation.

IMPORTANT

Keep this manual for future reference.

EQUIPMENT RECORD

Please provide the information below when you correspond with us about your machine.

Purchased by _____

Installed by _____

Date of installation _____ Model number _____

Serial number _____

092308

MN-1017EN

Belshaw Bros., Inc.

814 44TH ST NW Suite 103

Auburn, WA 98001 USA

Phone: 206-322-5474 • Fax: 206-322-5425

Email: service@belshaw.com • <http://www.belshaw.com>

Contents

1	Operation	1
	Taking Safety Precautions	1
	Making Cake Donuts	2
	Making Yeast-Raised Donuts	4
2	Cleaning	7
	Cleaning the Hopper and the Plunger	7
	Cleaning the Conveyor and the Kettle	8
3	Maintenance	13
	Taking Care of the Plunger, Hopper, and Cylinder	13
	Lubricating	13
4	Related Products	14
	FT-42 Feed Table	14
	Roto Cooler	17
	Icing Finishing Tree and Roto Cooler	19
	Sugaring Tray and Roto Cooler	21
	Filter Flo Siphon	22
	Shortening Reserve Tank	25
5	Donut-Making Helps	26
	Tips on Making Quality Cake Donuts	26
	Temperature Conversion	27
	Ratios of Plunger Sizes to Donut Weights	27
	Calculating Correct Water Temperature	27

Preface

The Donut Robot Mark II-Gas is designed to automatically cut and fry cake donut products, and to fry yeast-raised donut products. It is not designed to cut or fry any other products. The Mark II Gas is available for LP Gas and Natural Gas in the following electrical configurations:

- 120 volts, 1 phase, 50/60 hertz

The Mark II-Gas is designed to be used on a flat, stationary table or countertop, with the operator standing opposite the control box and flue stack of the machine. The operator must work safely at all times and read this manual and follow its instructions and warnings. Study the instructions and warnings in this manual carefully. A thorough understanding of how to install, maintain, and safely operate the Donut Robot Mark II-Gas will prevent production delays and injuries.

The Mark II Gas produces only 71.5 dB(A) of equivalent A-weighted sound pressure at workstations. This has been determined during a dry run of the machine, using a Bruel & Kjaer sound level meter, type 2236.

To use the Mark II-Gas safely, heed the following warnings and all other warnings that appear in this manual:

- Make sure the machine is secured to the work surface. Doing so will prevent the machine from moving or falling, which could cause serious injury.
- Never let water and hot shortening come in contact with each other. Moisture causes hot shortening to spatter, which may cause serious burns.
- Do not overfill the kettle with shortening. If shortening overflows the kettle, it could

cause serious burns or could cause someone to slip on the floor and be seriously injured.

- To avoid electrocution or other injury, unplug the machine before attempting any adjustment, repair, disassembly, or cleaning.
- Hot shortening can cause serious burns. Make sure that the system and the shortening are cool before attempting any adjustment, repair, disassembly, or cleaning.
- To avoid damaging the machine, never use force to assemble, disassemble, operate, clean, or maintain it.
- Be careful never to get shortening, water, or other materials on the floor. If anything does get spilled on the floor, mop it up immediately. Materials on the floor can cause people to slip or fall, resulting in serious injury or loss of life.
- To prevent unintentional startup and possible fire, unplug the machine if there is a local power outage. When the power is restored, it is safe to plug the machine in again.
- To avoid fire and personal injury, always shut the machine down completely and wait at least five minutes before igniting the pilot again.
- To avoid electrocution, make sure that all electrical cords are not frayed or cracked and that they do not pass through any water or shortening.
- Make sure that all electrical cords are routed so that no one will trip over them.
- To avoid serious injury or death, always keep the fryer area free and clear from combustible materials.

For general information on donut production, refer to Section 5, “Donut-Making Helps.”

Taking Safety Precautions

Contact your local gas supplier and obtain information about what to do if there is a gas leak. **Post this information in a prominent location. Make sure that all employees know what to do.**

WARNING

To avoid the possibility of fire, explosion, property damage, serious burns, and even death, never store gasoline or any other flammable liquid or vapor near the fryer.

WARNING

If you want to re-start the machine after you have shut it down, do the following:

- 1. Move the POWER switch on the control box to the OFF position. 2. Move the gas control valve to the PILOT position.**
- 3. Lightly press down the valve and turn it to the OFF position. 4. WAIT 5 MINUTES. 5. Re-light the pilot, as explained below.**

FAILURE TO WAIT 5 MINUTES FOR THE GAS TO DISSIPATE COULD RESULT IN A FIRE OR AN EXPLOSION WHEN YOU RE-LIGHT THE PILOT.

WARNING

To avoid serious injury or death, if you smell gas or suspect a gas leak, proceed as follows: 1. Turn off the gas. 2. Evacuate the building. 3. Do not touch any electrical switch or telephone until you are sure no spilled gas remains.

The fryer is bolted to the work surface to prevent it from tipping over and splashing hot liquid on the operator.

WARNING

To avoid serious burns, other injury, and even death, never move the fryer when liquid is in it. If you want to move the fryer, follow the instructions in “Moving the Fryer,” in Section 1, “Installation” in the Technical Supplement.

Making Cake Donuts

Read each step **completely** before doing what it tells you to do.

WARNING

To avoid serious injury or death, before you begin working, make sure that there is no combustible material in the area of the fryer.

1. If necessary, install the swing column, connect the swing connecting rod, install the cutter head, and install the hopper and the plunger.
2. Connect the machine to an appropriate power source.
3. Check the connection of the machine to the gas source to make sure that it is tight.
4. When the shortening reaches the correct frying temperature, it should reach the top of the flight bars.

Shortening expands as it increases in temperature. This means that unless the shortening is at frying temperature when you put it in the kettle, you should put it in gradually. Let the shortening in the kettle heat up before you add more.

Put shortening in the kettle using one of the these methods.

- Pre-melt shortening in a pan on the stove, heat only slightly to liquefy the shortening and carefully pour it into the kettle.

WARNING

Hot shortening causes severe burns.

- Use the optional EZ Melt to melt shortening and transfer it to the kettle. See your EZ Melt manual.
- Put solid shortening into the kettle, packing it tightly around the thermostat bulbs.

WARNING

Air spaces can cause the shortening to overheat and catch on fire.

5. Turn the combination gas control valve knob to the PILOT position.



5. Press and hold down the valve knob. At the same time, push the red ignition button until you can see a flame through the opening on the outfeed end of the fryer.



6. Continue holding down the valve knob for about 20 seconds. When you release the valve, make sure the flame is still on the pilot.

WARNING

If the pilot is out, do the following:

1. Turn the combination gas control valve knob to the PILOT position. 2. Lightly press down the valve knob and turn it to OFF. 3. WAIT 5 MINUTES. 4. Re-light the pilot. FAILURE TO WAIT 5 MINUTES FOR THE GAS TO DISSIPATE COULD RESULT IN A FIRE OR AN EXPLOSION WHEN YOU RE-LIGHT THE PILOT.

7. Move the valve knob switch to the ON position.



8. Set the thermostat to the desired setting. The pilot light on the control box will come on, indicating that the shortening temperature is lower than the desired temperature.
10. Note: If the high temperature limit control does break the circuit, push the red reset button on the back of the control box.
11. Wait for the shortening to reach the desired temperature. When it does, the pilot light will go out. DO NOT run the conveyor until all the shortening has melted.
12. If using the optional Shortening Reserve Tank, fill it with shortening. Then position it on the conveyor side panels either ahead of or behind the turner, but not above it. The heat of the fryer will melt the shortening in the tank.

13. Disengage the swing connecting rod from the swing column throw arm and swing the hopper away from over the fryer.
14. Adjust the size selector dial on the cutter head's crankshaft assembly. This dial regulates the donut weight. The higher the setting, the larger the donuts will be. Adjust the dial setting as follows:
 - a. Unscrew the dial lock nut 1/2 turn.
 - b. Turn the dial to the desired position, as indicated by the marks on the crank plate.
 - c. Tighten the dial in place with the lock nut. Tighten it using your fingers only.
15. Put dough into the hopper. Prime the hopper to expel any air that may be trapped in the bottom of it. To prime the hopper:
 - a. Hold a mixing bowl under the cutter.
 - b. Hold down the prime switch on the cutter head and run the cutter until it has dropped two or three donuts into the bowl.

Note: Holding down the prime switch causes the cutter to run continuously without the normal delay between cuts.
 - c. Put the dough in the bowl back in the hopper.
16. Return the hopper into position over the fryer and reconnect the swing connecting rod to the swing column throw arm.
17. Choose the appropriate fry time for your product using the fry time control knob on the control box.
18. Using the switch on the control box, select the number of donuts—one or two—you want to cut during each swing cycle of the hopper.
19. Turn on the cutter using the power switch on the cutter head.
20. Turn on the conveyor drive using the power switch on the control box.

Note: If the conveyor becomes jammed, a warning buzzer will sound about a minute later and the buzzer will stop when the conveyor is turned off. The conveyor drive is impedance-protected so it will not burn out due to jamming.

WARNING

If the conveyor becomes jammed: 1. Turn off the conveyor drive and the heater. 2. Allow the system to cool down. HOT SHORTENING IS DANGEROUS. 3. Determine the cause of the jamming. 4. Clear it. 5. Restart the system.

21. Continue adding shortening to the kettle to maintain the proper shortening level (see step 4). There are three ways to do this:
 - Melt some shortening in a pan on the stove and carefully pour it into the kettle.
 - If you are using the optional EZ Melt, transfer more shortening from it. See your EZ Melt manual.
 - If you are using the optional Shortening Reserve Tank, push open the supply valve.
22. Continue adding dough to the hopper as needed. You can add dough to the hopper without priming it again as long as it does not become empty. If the hopper does become empty, you must prime it again.
23. When you fill the hopper for the last time, you will want to use all of the dough in the hopper. To do so, push the dough to the bottom of the hopper using a rubber scraper or spatula. Be careful not to jam the scraper in the donut cutter.

WARNING

To avoid injury, never put your hand in or under the hopper while the machine is on.

24. To shut down the machine when you are done:
 - a. Move the POWER switch on the control box to the OFF position.
 - b. Turn the combination gas control valve knob to the PILOT position. Lightly press down the valve knob and turn it to the OFF position.

Making Yeast-Raised Donuts

Read each step completely before doing what it tells you to do.

WARNING

To avoid serious injury or death, before you begin working, make sure that there is no combustible material in the area of the fryer.

1. Remove the hopper and plunger, the cutter head, and the swing column, if they are installed.
2. Connect the machine to an appropriate power source.
3. Check the connection of the machine to the gas source to make sure that it is tight.
4. When the shortening reaches the correct frying temperature, it should reach the top of the flight bars.

Shortening expands as it increases in temperature. This means that unless the shortening is at frying temperature when you put it in the kettle, you should put it in gradually. Let the shortening in the kettle heat up before you add more.

Put shortening in the kettle using one of these methods:

- Pre-melt shortening in a pan on the stove, heat slightly to liquefy and carefully pour it into the kettle.

WARNING

Hot shortening causes severe burns.

- Use the optional EZ Melt to melt shortening and transfer it to the kettle. See your EZ Melt manual.
- Put solid shortening into the kettle, packing it tightly around the thermostat bulbs.

WARNING

Air spaces can cause the shortening to overheat and catch on fire.

5. Turn the combination gas control valve to the PILOT position.
6. Press and hold down the valve. At the same time, push the red ignition button until you can see a flame through the opening on the outfeed end of the fryer.
7. Continue holding down the valve for about 20 seconds. When you release the valve, make sure the flame is still on the pilot.

WARNING

If the pilot is out, do the following:

1. Turn the combination gas control valve to the PILOT position.
2. Lightly press down the valve and turn it to the OFF position.
3. Wait 5 minutes.
4. Re-light the pilot, as explained above. Failure to wait 5 minutes for the gas to dissipate could result in a fire or an explosion when you re-light the pilot.

8. Move the POWER switch to the ON position.
9. Set the thermostat to the desired setting. A pilot light on the control box will come on, indicating that the shortening is heating up to the desired temperature. It will go out if the high temperature limit control breaks the circuit.

Note: If the high temperature limit control does break the circuit, push the red reset button on the back of the control box.

10. Wait for the shortening to reach the desired temperature. When it does, the pilot light will go out. DO NOT run the conveyor until all the shortening has melted.
11. If are using the optional Shortening Reserve Tank, fill it with shortening. Then position it on the conveyor side panels either ahead of or behind the turner, but not above it. The heat of the fryer will melt the shortening in the tank.
12. Install your Feed Table and load proof cloths on it. Refer to Section 4, "Related Products," for complete installation and operation instructions for the Feed Table.
13. Choose the appropriate fry time for your product using the fry time control knob on the control box.
14. Turn on the conveyor drive using the power switch on the control box.

Note: If the conveyor becomes jammed, a warning buzzer will sound about a minute later and the buzzer will stop when the conveyor is turned off. The conveyor drive is impedance-protected so it will not burn out due to jamming.

WARNING

If the conveyor becomes jammed: 1. Turn off the conveyor drive and the heater. 2. Allow the system to cool down. HOT SHORTENING IS DANGEROUS. 3. Determine the cause of the jamming. 4. Clear it. 5. Restart the system.

15. Continue adding shortening to the kettle to maintain the proper shortening level (see step 4). There are three ways to do this:
 - Melt some shortening in a pan on the stove and carefully pour it into the kettle.
 - If you are using the optional EZ Melt, transfer more shortening from it. See your EZ Melt manual.
 - If you are using the optional Shortening Reserve Tank, push open the supply valve.
16. Continue loading proof cloths onto the Feed Table as needed.
17. To shut down the machine when you are done:
 - a. Move the POWER switch on the control box to the OFF position.
 - b. Turn the combination gas control valve to the PILOT position. Lightly press down the valve and turn it to the OFF position.

WARNING

Thoroughly clean and dry the floor if shortening, water, or other materials that spill. Materials spilled on the floor can cause serious injury or loss of life.

WARNING

To avoid electrocuting yourself or damaging the machine, never allow water, steam, shortening, cleaning solution, or any other liquid to enter the control box or the cutter head assembly.

Cleaning the Hopper and the Plunger

General guidelines:

- Use household dishwashing detergent. Do not use strong alkali cleaners such as lye, soda ash, or trisodium phosphate, as these discolor and corrode aluminum.
- Wash, dry, and lubricate parts thoroughly to prevent rusting.
- When washing parts by hand, wash each part separately; do not put any other utensil or dish in the sink with the part being washed.

To clean the hopper and the plunger:

1. Unplug the cutter head power cord.
2. Remove the plunger and the hopper. To do so, reverse the procedures found in Steps 2 and 3 of “Assembling the Cutter” in Section 1 of the Technical Supplement.
3. Pre-soak the parts, if necessary, to loosen stubborn or dried-on deposits.
4. Wash the hopper and the plunger separately in hot water and a detergent recommended for aluminum. Use a non-scratching plastic scouring cloth to remove soil and restore luster.
5. Rinse the hopper and the plunger separately in clear, hot water (170°-190°F/77°-88°C).
6. Dry each part completely.
7. Dip the plunger and the hopper cylinder in mineral oil or liquid shortening to prevent rust and sticking.
8. Wipe the cutter head assembly with a soft cloth dampened with hot water and an appropriate cleaner. Wipe it with another damp cloth to remove the cleaner. Wipe it dry.

CAUTION

To avoid electrocuting yourself or damaging the machine, never immerse the cutter head assembly.

Cleaning the Conveyor and the Kettle

There are three basic steps to cleaning the conveyor and the fryer kettle: removing the shortening, washing, rinsing, and drying. You must perform all four steps and perform them in the order listed.

Removing the Shortening

WARNING

To avoid being burned or electrocuted, disconnect the machine from the power source before cleaning the fryer.

1. Disconnect the machine from the power source.
2. Let the shortening cool to 100°F/38°C.
3. Unplug the cutter head power cord.
4. Lift the cutter head off the swing column.
5. Remove the conveyor assembly as follows:
 - a. Obtain two pieces of wood, at least 1" x 1" x 15" (2.5 cm x 2.5 cm x 38 cm).
 - b. Lift off the swing connecting rod.
 - c. Lift the conveyor assembly from the conveyor locating pin and pull it away from the control box to disengage the main drive shaft coupling from the conveyor drive coupling.
 - d. Lift the outfeed end of the conveyor. Slide one piece of wood under the conveyor and lay it across the top of the kettle. Lift the other end of the conveyor and do the same thing with the other piece of wood. The conveyor will now be resting on the two pieces of wood. Let the shortening drain off of the conveyor and into the kettle. See Figure 2-1.



Figure 2-1. Draining the Shortening off of the Conveyor.

6. Remove the turner assembly as follows:
 - a. Move the flight bars of the conveyor until the turner is in the middle of a flight pocket.
 - b. Swing the turner cam weight up out of position.
 - c. Lift up and pull out on the turner cam assembly. See Figure 2-2.

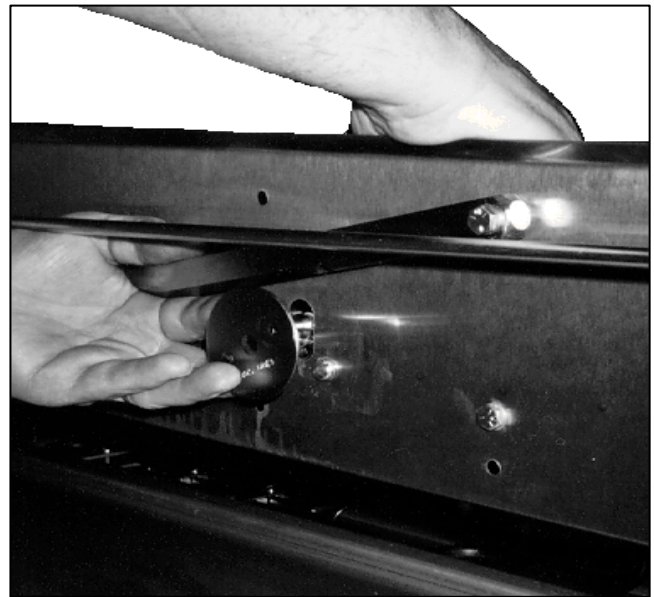

Figure 2-2. Removing the Turner Cam Assembly.



Figure 2-3. Removing the Turner Assembly.

- d. Lift out the turner assembly. See Figure 2-3.
 - e. To reassemble, reverse this procedure.
7. Remove the drop plate at the infeed end of the conveyor by lifting the forward end and sliding it toward the rear of the conveyor. (See Figure 2-4.) Wipe it clean with a damp cloth. Do not clean the drop plate with an abrasive cleaner, as doing so will cause donuts to stick to it.

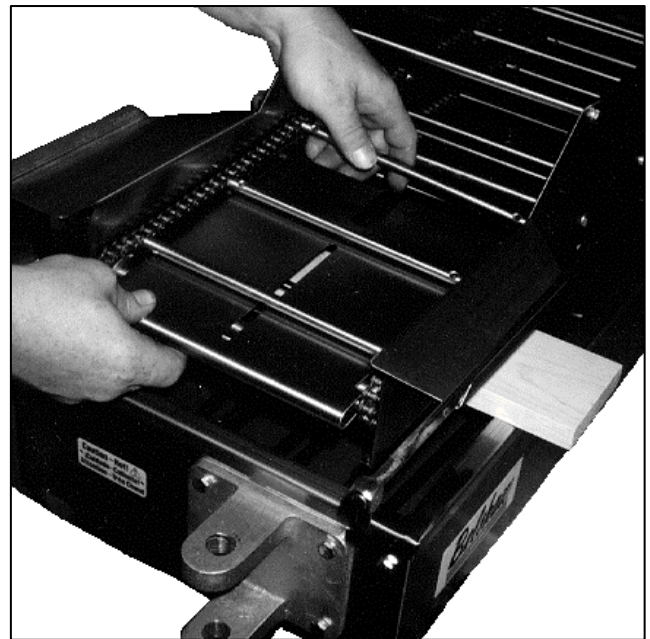

Figure 2-4. Removing the Drop Plate.

8. After the shortening has drained off of the conveyor assembly, set the conveyor assembly aside.
9. Check again to see that the shortening in the kettle has cooled to 100°F/38°C.
10. Remove the shortening from the kettle using one of these methods:
 - Use an optional Filter Flo Siphon to siphon the shortening into one or more large metal buckets. (See the instructions in Section 4.) Be careful not to disturb the sediment that has accumulated in the bottom of the kettle.
 - Tilt the control box assembly back, raising the thermostat and high limit out of the kettle. Lift the kettle out of the fryer case and carefully pour the shortening into one or more large metal buckets. Be careful not to disturb the sediment that has accumulated in the bottom of the kettle.

- Using a small saucepan or a metal pitcher, scoop as much of the shortening as you can into one or more large metal buckets. Then lift the kettle out of the fryer case and carefully pour the rest of the shortening into a metal bucket. Be careful not to disturb the sediment that has accumulated in the bottom of the kettle.

WARNING

Do not use plastic buckets. If the shortening is not cool enough, the buckets will melt; possibly causing you to be burned, and causing shortening to get on the floor.

WARNING

Do not allow the shortening to overflow the buckets. Shortening will get on the floor, and if the shortening is not cool enough, you may be burned.

WARNING

Thoroughly clean and dry the floor if shortening does spill. Shortening on the floor can cause serious injury or loss of life.

11. Return the kettle to the fryer case, if you have removed it.
12. Tilt the control box assembly back, raising the thermostat and high limit out of the kettle.
13. Lift the kettle out of the fryer case. Remove and dispose of the remaining shortening and the accumulated sediment. Dry the outside of the kettle.
14. Put the kettle back in the fryer case.
15. Tilt the control box assembly down.

16. Put the drop plate and the turner assembly back on the conveyor assembly.
17. Install the conveyor assembly.

Washing

1. Pour hot water into the kettle, up to the normal level of the shortening. Add about 2 oz/59 ml of trisodium phosphate or other appropriate cleaner.
2. Connect the machine to the power source. Heat the solution to 200°F/93°C. Turn on the conveyor. Keep the solution at this temperature for 15-20 minutes.
3. Turn off the conveyor and scrub the soiled parts while the solution is under heat. Do not use any abrasive cleaners or scrapers.
4. Turn off the heater and disconnect the machine from the power source. Allow the cleaning solution to cool to 100°F/38°C.
5. Remove the conveyor and tilt the control box back as you did before.
6. Remove the cleaning solution from the kettle using one of these methods:
 - If you have an optional Filter Flo Siphon, remove its filter assembly. Then use the Filter Flo to siphon the cleaning solution into one or more large metal buckets. (See the instructions in Section 4.) When the cleaning solution has stopped draining, carefully carry the buckets to the sink and slowly pour the solution into the sink.
 - Lift the kettle out of the fryer case, carefully carry it to the sink, and slowly pour the cleaning solution into the sink.
 - Using a small saucepan or a metal pitcher, scoop as much of the cleaning solution as you can into one or more large metal buckets. Then lift the kettle out of the fryer case and carefully pour the rest of the cleaning solution into a metal bucket. Carefully carry the

buckets to the sink and slowly pour the solution into the sink.

WARNING

Do not use plastic buckets. If the cleaning solution is not cool enough, the buckets will melt; possibly causing you to be burned, and causing cleaning solution to get on the floor.

WARNING

Do not allow the cleaning solution to overflow the buckets. Cleaning solution will get on the floor, and if the solution is not cool enough, you may be burned.

WARNING

Thoroughly clean and dry the floor if cleaning solution is to spill. Liquid on the floor can cause serious injury or loss of life.

7. Lift the kettle out of the fryer case, if you have not done so already.
8. Rinse the kettle thoroughly and dry it on the outside.
9. Install the kettle, tilt the control box assembly down, and install the conveyor assembly as before.

Rinsing

1. Pour clean water into the kettle, up to the normal level of the shortening.
2. Connect the machine to the power source. Heat the water to 200°F/93°C.
3. Run the conveyor for 5-10 minutes.
4. Turn off the heater and disconnect the machine from the power source. Allow the water to cool to 100°F/38°C.

5. Lift the conveyor assembly out of the fryer case. Tilt the control box assembly back.
6. Remove the water from the kettle using one of these methods:
 - If you have an optional Filter Flo Siphon, remove its filter assembly. Then use the Filter Flo to siphon the cleaning solution into one or more large metal buckets. (See the instructions in Section 4.) When the cleaning solution has stopped draining, carefully carry the buckets to the sink and slowly pour the solution into the sink.
 - Lift the kettle out of the fryer case, carefully carry it to the sink, and slowly pour the cleaning solution into the sink.
 - Using a small saucepan or a metal pitcher, scoop as much of the cleaning solution as you can into one or more large metal buckets. Then lift the kettle out of the fryer case and carefully pour the rest of the cleaning solution into a metal bucket. Carefully carry the buckets to the sink and slowly pour the solution into the sink.

WARNING

Do not use plastic buckets. If the water is not cool enough, the buckets will melt; possibly causing you to be burned, and causing water to get on the floor.

WARNING

Do not allow the water to overflow the buckets. Water will get on the floor, and if the water is not cool enough, you may be burned.

WARNING

Thoroughly clean and dry the floor if water does spill. Water on the floor can cause serious injury or loss of life.

7. Lift the kettle out of the fryer case, if you have not done so already.

Drying

1. Thoroughly dry all parts, including the conveyor, the heating element(s), the inside of the kettle, and the drain.

WARNING

All parts must be dried thoroughly. Failure to dry the kettle, conveyor, and all parts of the Donut Robot completely will cause spattering or an eruption. Shortening will spatter or overflow the fryer and may result in fire, injury, or death.

2. Assemble the Donut Robot as before.
3. Make sure no water is in the drain or drain tube.
4. If your kettle has the optional drain valve assembly, close the drain valve.

WARNING

To avoid being burned, electrocuted, or otherwise injured, always unplug the machine and allow it to cool down before making adjustments, clearing obstructions, lubricating, cleaning, or disassembling.

Taking Care of the Plunger, Hopper, and Cylinder

The plunger, hopper, and cylinder of your Donut Robot are precision instruments. If you take good care of them, they will perform well for years. Follow these guidelines:

- Clean these parts only in the manner explained in this manual.
- Handle these parts with care. Avoid dropping them on hard surfaces.
- Do not force the machine if it becomes jammed. To avoid damaging the plunger, disassemble the machine and remove any obstructions.

Lubricating**Daily**

Before using the machine each day, apply edible-grade mineral oil to the plunger connecting rod. The oil should penetrate the ball lock and the spring socket. See Figure 3-1.

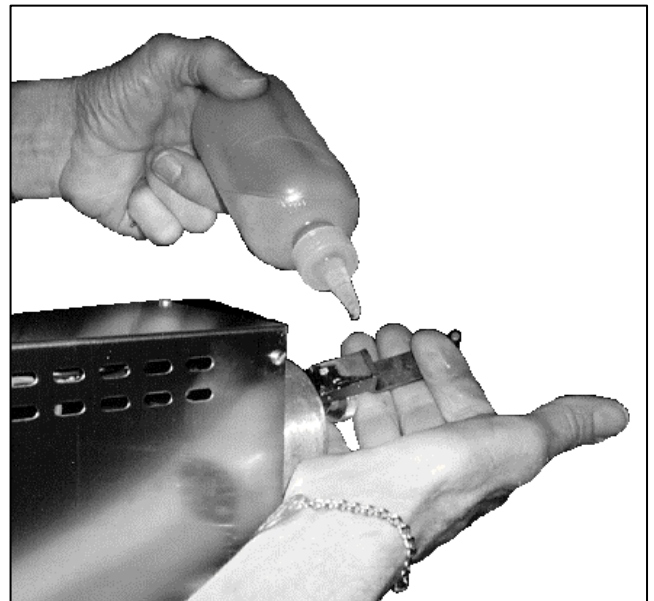

Figure 3-1. Lubricating the Connecting Rod.

Weekly

Apply a few drops of SAE 30 machine oil to the swing column where it contacts the swing column bracket.

4

Related Products

This appendix contains information about the following products which you might use with your Donut Robot®:

- Feed Table
- Roto Cooler
- Icing Finishing Tree and Roto Cooler
- Sugaring Tray and Roto Cooler
- Filter Flo Siphon
- Shortening Reserve Tank

FT-42 Feed Table

SPECIFICATIONS				
Dimensions	Shipping Weight	Electrical Data	Construction	Standard Equipment
L = 52"/132 cm W = 19"/48 cm H = 11 3/4"/ 30 cm	73 lb/33.1 kg	115 V 1 Phase 50 or 60 Hz	Stainless steel, nickel-plated mild steel, and aluminum alloys.	Complete conveyor assembly, including drive system and controls. Does not include proofing cloths or proofing boards.

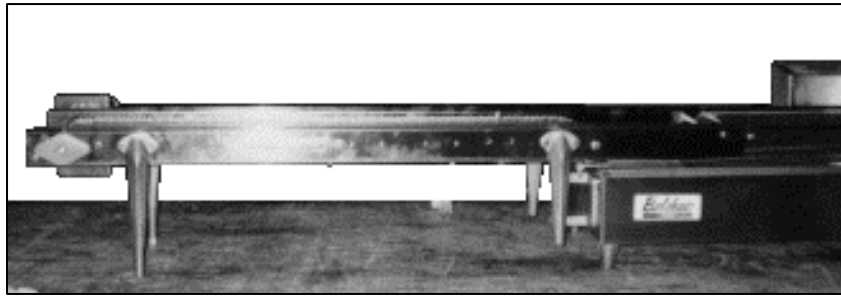

Figure 4-1. FT-42 Feed Table.

The FT-42 Feed Table is designed to supply proofed yeast-raised donuts to the Donut Robot. It is meant to be used on a flat, stationary table or countertop, positioned end-to-end with the Donut Robot. The operator is expected to read and follow these instructions.

Installation

1. Unplug the cutter head power cord of your Donut Robot.
2. Release the plunger from the cutter head.
3. Unscrew and lift off the hopper assembly.
4. Lift off the cutter head and swing column assemblies.
5. Lift the outfeed end of the Feed Table and set the brace under the trip shelf over the edge of the kettle.

WARNING

To avoid injury, make sure that the Feed Table is turned off before proceeding.

6. Plug the Feed Table power cord into the outlet on the end of the heater head.
7. Set the Donut Robot to cut one cut per pocket.

Operation

1. Test to make sure that the automatic timing for the Feed Table is working. To do this:
 - a. Turn on the Donut Robot's conveyor drive.
 - b. Turn on the Feed Table's conveyor drive.

The Feed Table should receive a signal from the Donut Robot, move forward the distance needed to supply one pocket of donuts, and then stop until it receives the next signal.

2. Proof your donuts on the proofing cloths from the Feed Table.
3. Put a proofing board, with a proofing cloth on it, on the Feed Table.
4. Press the prime switch on the power head assembly. The hooks on the Feed Table will grab the proofing cloth off of the proofing board. Allow the cloth to advance to the front of the Feed Table.
5. Release the prime switch and turn on the main power. Remove the proofing board.

When the Feed Table is on, the Feed Table automatically advances donuts when the Donut Robot is ready to accept them. After the donuts go into the fryer, the proofing cloths are carried underneath the Feed Table and fall onto the work surface.
6. Continue putting proofing cloths on the Feed Table.

CAUTION

To avoid damaging the machine, never use force to assemble or operate the Feed Table.

Maintenance and Cleaning

After Each Use

Use a soft, damp cloth for cleaning.

WARNING

To avoid electrocuting yourself or damaging the machine, never allow any liquid to enter the power head.

As Needed

If you ever need to adjust the tension of the conveyor chains, follow these steps:

1. Loosen the hex head bolts that hold the roller shaft at the outfeed end of the conveyor.
2. Pull the shaft until the chains reach the correct tension. The tension is correct when you can lift the chains about 1"/2.5 cm above the surface of the Feed Table. Each chain should have the same tension.
3. Tighten the hex head bolts that hold the roller shaft.

Roto Cooler

SPECIFICATIONS				
Dimensions	Shipping Weight	Electrical Data	Construction	Standard Equipment
Dia.=24"/61 cm H=6-5/8"/17 cm	16 lb/7.3 kg	120 V 1 Phase 50 or 60 Hz	Basket: High-density polyethylene. Base: Spun, polished, heavy-gauge aluminum.	Basket and turntable base with power cord and motor.



Figure 4-2. Roto Cooler.

The Roto Cooler is designed to catch and cool donuts as they drop from the outfeed end of the Donut Robot. It is meant to be used on a flat, stationary table or countertop. The operator is expected to read and follow these instructions.

To use the Roto Cooler:

1. Place the Roto Cooler near the outfeed end of the Donut Robot so donuts will fall into it.
2. Connect the Roto Cooler power cord to the 120 V outlet on back of the Donut Robot's heater head.
3. Turn on the Roto Cooler. It will rotate and receive donuts. Remove cooled donuts from the Roto Cooler as needed.
4. When you are finished using the Roto Cooler, turn it off and unplug it.

WARNING

To avoid electrocuting yourself or damaging the machine, never submerge the base of the Roto Cooler.

5. Clean the Roto Cooler using soap and water and a non-abrasive cloth or scrubber.

On the following pages are a wiring diagram and a parts list for the Roto Cooler.

FIGURE 4-3. ROTO COOLER MAIN ASSEMBLY.

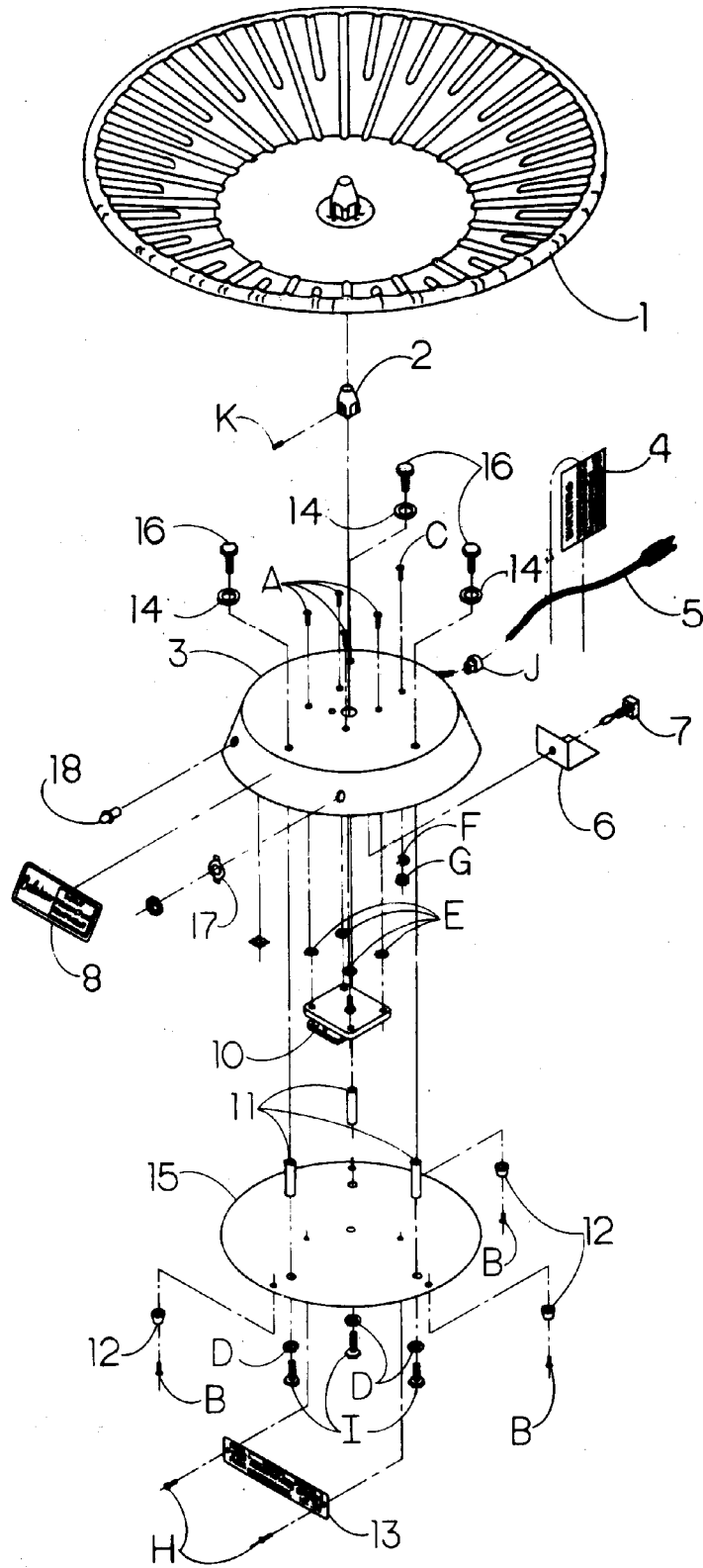

Icing Finishing Tree and Roto Cooler

SPECIFICATIONS				
Dimensions	Shipping Weight	Electrical Data	Construction	Standard Equipment
Dia.=24"/61 cm H=32"/81 cm	28 lb/12.7 kg	120 V 1 Phase 50 or 60 Hz	Trays: Heavy-gauge aluminum. Basket: High-density polyethylene. Base: Spun, polished, heavy-gauge aluminum.	Power turntable and four trays, three of which have dividers.



Figure A-4. Icing Finishing Tree and Roto Cooler.

The Roto Cooler is designed to catch and cool donuts as they drop from the outfeed end of the Donut Robot. It is meant to be used on a flat, stationary table or countertop.

The Icing Finishing Tree, which mounts on the Roto Cooler, is designed to hold toppings in which donuts can be dipped. The operator is expected to read and follow these instructions.

To use the Roto Cooler and the Icing Finishing Tree:

1. Attach the Icing Finishing Tree to the Roto Cooler. Fill the metal trays with toppings.
2. Install and operate the Roto Cooler as explained in the previous section.
3. Decorate the donuts with the toppings in the trays.
4. When you are finished using the Roto Cooler and the Icing Finishing Tree, turn off the Roto Cooler and unplug it.

WARNING

To avoid electrocuting yourself or damaging the machine, never submerge the base of the Roto Cooler.

5. Clean the trays of the Roto Cooler and the Icing Finishing Tree using soap and water and a non-abrasive cloth or scrubber.

On the following page is a parts illustration for the Icing Finishing Tree.

FIGURE 4-5. ICING FINISHING TREE MAIN ASSEMBLY.

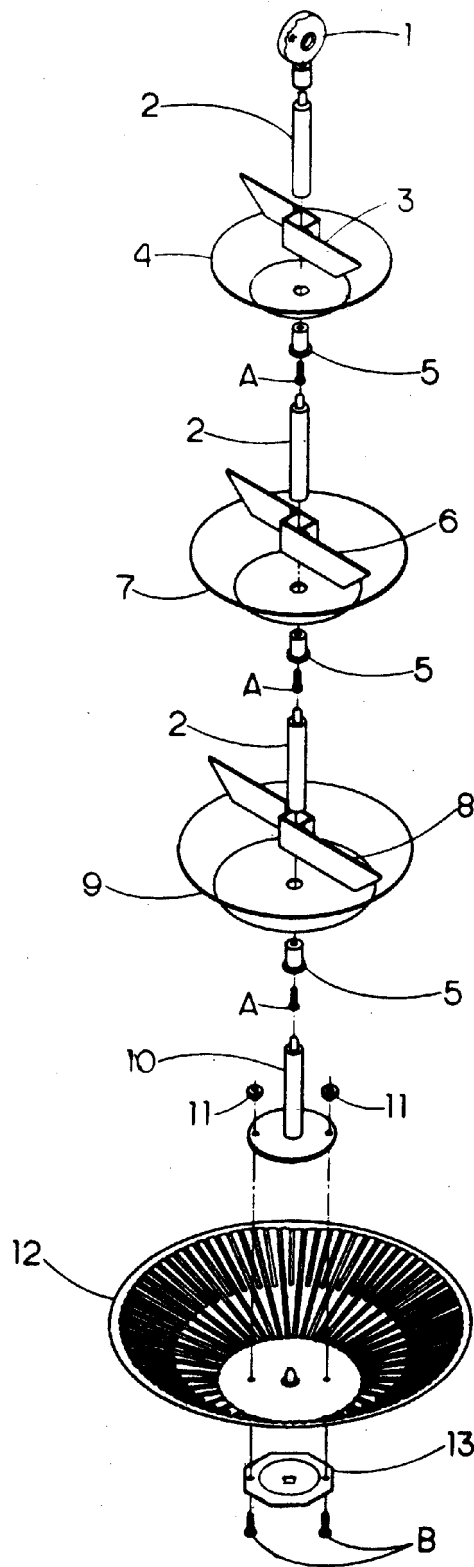

Sugaring Tray and Roto Cooler

SPECIFICATIONS				
Dimensions	Shipping Weight	Electrical Data	Construction	Standard Equipment
Dia.=17-1/4"/ 44 cm H=6-5/8"/17 cm	16 lb/7.3 kg	120 V 1 Phase 50 or 60 Hz	Spun, polished, heavy-gauge aluminum.	Power turntable with sugar tray.



Figure 4-6. Sugaring Tray.

The Roto Cooler base makes the Sugaring Tray rotate. It is meant to be used on a flat, stationary table or countertop.

The Sugaring Tray, which mounts on the Roto Cooler base, is designed to catch donuts as they drop from the outfeed end of the Donut Robot, and to hold toppings in which donuts can be dipped. The operator is expected to read and follow these instructions.

To use the Sugaring Tray and Roto Cooler base:

1. Put sugar, powdered sugar, or cinnamon-sugar in the tray.
2. Place the Sugaring Tray and Roto Cooler base near the outfeed end of the Donut Robot so donuts will fall into the tray.
3. Connect the Roto Cooler power cord to the 120 V outlet on back of the Donut Robot's heater head.
4. Turn on the Roto Cooler base. The Sugaring Tray will rotate and receive donuts.
5. Coat the donuts with the topping in the tray.
6. When you are finished using the Sugaring Tray, turn off and unplug the Roto Cooler base.

WARNING

To avoid electrocuting yourself or damaging the machine, never submerge the base of the Roto Cooler.

7. Clean the Sugaring Tray using soap and water and a non-abrasive cloth or scrubber.

Filter Flo Siphon

SPECIFICATIONS			
Dimensions	Shipping Weight	Construction	Standard Equipment
H=16"/41 cm Dia.=6-1/4"/16 cm	3 lb/1.4 kg	Siphon tube and valve: nickel-plated steel. Handle: wood. Filter ring: powder-coated. Filters: flannel. Mounting brackets: aluminum alloy.	Siphon assembly including valve, filter, filter ring, and clamp.

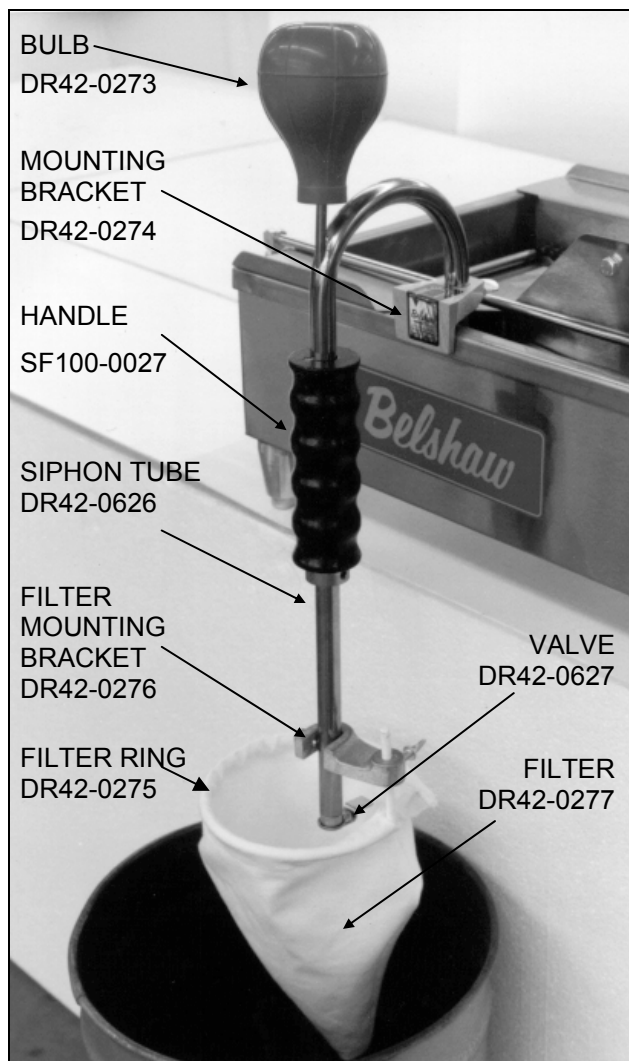

Figure 4-7. Filter Flo Siphon.

The Filter Flo Siphon is designed to drain and filter shortening from the kettle of the Donut Robot. The operator is expected to read and follow these instructions.

Installation

1. Let the shortening cool to 100°F/38°C.

WARNING

Hot shortening can cause serious burns. Never touch hot shortening. Never wear shorts while using the Filter Flo Siphon.

2. Place the mounting bracket, with the siphon tube in it, on the lip of the kettle. You may place it on the infeed end of the kettle, or on the front side of the kettle. If you place it on the front side, you must disconnect the swing connecting rod from the throw arm and move it out of the way.
3. Position the opening of the siphon tube near the bottom of the kettle.
4. Tighten the thumb screw in the mounting bracket.

5. Attach the filter assembly to the lower part of the siphon tube, as shown in Figure 4-7. To do this:
 - a. Slide the opening in the filter mounting bracket around the siphon tube.
 - b. Adjust the filter mounting bracket vertically to ensure that the filter does not touch the valve assembly.
 - c. Tighten the screw that holds the filter mounting bracket to the siphon tube.
 - d. Tighten the screw that holds the filter retaining ring to the filter mounting bracket.

WARNING

Make sure that both screws in the filter assembly are tight. If they are not, the filter assembly might slide off of the siphon tube during operation, causing shortening to splatter.

6. Place a five-gallon metal container under the filter.

WARNING

Do not use a plastic container. Hot shortening could melt the container, possibly burning you and getting shortening on the floor. Shortening on the floor could cause you to slip or fall, resulting in injury or even death.

Operation

1. Compress the bulb quickly and release it quickly. Do this only once. Shortening should flow into the container.

CAUTION

Do not compress the bulb more than once. Doing so could allow hot shortening to get into the bulb, damaging your equipment.

2. Watch the container as the shortening flows into it. If the shortening rises to within 2” (5 cm) of the top of the container, do the following:
 - a. With one hand, hold the siphon by the handle. With the other hand, loosen the thumb screw that holds the siphon assembly to the mounting bracket on the lip of the kettle.
 - b. Slowly lift the siphon assembly so its opening is above the shortening. Do not remove it from the mounting bracket.
 - c. Tighten the thumb screw.
 - d. When the shortening stops flowing and the valve closes, move the container out from under the filter.
 - e. Place another five-gallon metal container under the filter.
 - f. With one hand, hold the siphon by the handle. With the other hand, loosen the thumb screw that holds the siphon assembly to the mounting bracket on the lip of the kettle.
 - g. Slowly lower the siphon assembly so its opening is near the bottom of the kettle.
 - h. Tighten the thumb screw.
 - i. Restart the siphon, as explained in step 1.
 - j. Continue watching the container and repeat the above procedure as needed.

WARNING

If you allow shortening to overflow the container, the shortening could burn you, and it will get on the floor, possibly causing slips, falls, injury, or even death. If shortening does get on the floor, thoroughly clean and dry the floor right away.

3. When the shortening stops flowing, tilt up the side of the kettle opposite the siphon. Place a wedge under the side of the kettle to hold it up. The remaining shortening will now flow toward the siphon.
4. Set aside the container of shortening.
5. Remove the filter assembly.
6. Place a different container under the valve assembly and start the siphon again. Drain the remaining shortening and discard it; it will be full of sediment.

Cleaning

1. Remove the siphon from the Donut Robot.
2. Squeeze the bulb several times to expel shortening from the siphon.
3. Wipe the siphon clean and hang it with the bulb side up so any remaining shortening will drain. Place a pan under the siphon to collect the shortening.
4. Rinse the filter bag and hang it to dry. You may launder it as needed.

WARNING

After washing, be sure the Filter Flo Siphon is completely dry before using it again. Moisture will cause hot shortening to spatter, which may cause serious injury.

Shortening Reserve Tank

SPECIFICATIONS				
Dimensions	Shipping Weight	Capacity	Construction	Standard Equipment
L=11"/28 cm W=5-1/2"/14 cm D=4"/10 cm	4 lb/2 kg	4 lb/2 kg shortening	Nickel-plated steel tank and non-corrosive self-closing valve.	Shortening reserve tank and valve assembly.

The Shortening Reserve Tank is designed to supply melted shortening to the kettle of the Donut Robot. The operator is expected to read and follow these instructions.

To use the Shortening Reserve Tank:

1. Position the Shortening Reserve Tank on the conveyor side panels. Make sure that you do not position it above the donut turner.
2. Place shortening in the tank.
3. Turn on the Donut Robot. The heat of the fryer will melt the shortening in the tank.
4. To supply shortening to the fryer, open the valve by pushing down on the valve assembly.
5. When you are done making donuts, drain the remaining shortening into the fryer.
6. When the shortening and equipment have cooled completely, remove the Shortening Reserve Tank and wash it.

WARNING

Be careful if you put hot shortening into the tank. Hot shortening can cause serious burns.

5

Donut-Making Helps

Tips on Making Quality Cake Donuts

- Use the correct batter temperature.

In general, the correct batter temperature is 75°-80°F/24°-27°C. Check the mix manufacturer's instructions, as the recommended temperature range may vary.

If the batter is too warm, the donuts will lack volume and may "ring out" or be misshapen. If the batter is too cold, the donuts will stay under the shortening too long, fry too slowly, and crack open or ball up. They may also absorb excess shortening and lose volume.

- Use the correct floor time.

A floor time of 10 minutes between mixing and cutting allows the baking powder to react with the water. This helps the donuts attain the proper volume the proper level of shortening penetration.

If the floor time exceeds 30 minutes, the mix will gas off, the donuts will lose volume and shape and will absorb too much shortening.

- Use the correct frying temperature.

The correct shortening temperature for frying is 370°-380°F/188°-193°C.

If the shortening is too hot, the donuts will fry too quickly on the outside and will lose volume. The donuts may also become dense inside.

If the shortening is too cold, the donuts will spread too rapidly, will form large rings, will tend to crack open, will be too light in appearance, and will absorb too much shortening.

- Maintain the proper shortening level. We recommend a distance of 1 1/4" between the cutter and the shortening.

If the shortening is too deep, the donuts may not turn over when they reach the turner, causing them to cook unevenly.

If the shortening is too shallow (too far below the cutter), the donuts may not drop flat, may turn over while submerging and surfacing, and may become irregular, cracked, or rough-crusted.

- Ensure that the donuts absorb the right amount of shortening.

Donuts should absorb 1-1/2 to 3 oz/42 to 85 g of shortening per dozen, depending on their weight. You can achieve proper absorption by following tips 1-3.

- If the donuts do not absorb enough shortening, they will not keep well.

If they absorb too much shortening, they will lose volume and may become misshapen. If this happens, follow tips 1-3, mix the batter a little longer than usual, turn the donuts as soon as they become golden brown, and turn the donuts only once.

Temperature Conversion

To convert temperatures from Fahrenheit to Celsius, subtract 32 from °F and divide the result by 1.8. For example, $212^{\circ}\text{F} - 32 / 1.8 = 100^{\circ}\text{C}$.

To convert temperatures from Celsius to Fahrenheit, multiply °C by 1.8 and add 32 to the result. For example, $(100^{\circ}\text{C} \times 1.8) + 32 = 212^{\circ}\text{F}$.

°F	°C	°F	°C
55	12.8	340	171.1
60	15.6	345	173.9
65	18.3	350	176.7
70	21.2	355	179.4
75	23.9	360	182.2
80	26.7	365	185.0
325	162.8	370	187.8
330	165.6	375	190.6
335	168.3	380	193.3

Ratios of Plunger Sizes to Donut Weights

The weights given are for donuts without icings or other toppings. They are provided for reference only, as weights vary according to the density of the batter.

Plunger Size	Donut Weight per Dozen
1"	5-8 oz/142-227 g
1 7/16"	10-17 oz/283-482 g
1 9/16"	14-21 oz/397-595 g
1 13/16"	19-23 oz/539-652 g

Calculating Correct Water Temperature

The following is an example of how to calculate the correct water temperature to use. You must use your own room temperature, dry mix temperature, desired batter temperature, and, if you are making yeast-raised donuts, estimated temperature increase during mixing.

	Cake Donuts		Yeast-Raised Donuts	
	°F	°C	°F	°C
Room temperature	72	22.2	72	22.2
Dry mix temperature	+70	+21.1	+70	+21.1
Total A	142	43.3	142	43.3
Desired batter temperature	75	23.9	80	26.7
	<u>x3</u>	<u>x3</u>	<u>x3</u>	<u>x3</u>
Total B	225	71.7	240	80.1
Total B	225	71.7	240	80.1
-Total A	-142	-43.3	-142	-43.3
Desired water temp. for cake donuts	83°F	28.4°C	98	36.8
			↓	↓
			98	36.8
Temperature increase during mixing (average: 30°F/17°C)			<u>-30</u>	<u>-17</u>
Desired water temperature for yeast-raised donuts	68°F		68°F	19.8°C



Donut Robot® Mark II-Gas

Technical Supplement

Belshaw Bros., Inc.
814 44th Street NW, Suite 103
Auburn, WA 98001 USA
Phone: 1-206-322-5474 • Fax: 1-206-322-5425
Email: service@belshaw.com • <http://www.belshaw.com>

If you accept the machine from the shipping company, you are, in effect, saying that the machine is in good condition, and you must pay for the machine. Belshaw cannot pay for shipping damage, because the freight company has accepted the machine from Belshaw in good condition, and is responsible for its safe delivery. **For your protection,** inspect the machine to see that no parts are bent, scratched, or otherwise damaged. If any damage has occurred in shipping, file a freight claim with the shipping company immediately.

To unpack the Donut Robot® Mark II-Gas and transport it to the workstation requires two people:

3. Remove the foam and other packing materials from the two boxes.
4. Carry the hopper, plunger, and swing column to the work station.
3. Coil the cutter head power cord and carry the cutter head to the work station.
4. Carry the conveyor assembly the work station.
5. Move the fryer to the workstation.

IMPORTANT

Keep this manual for future reference.

EQUIPMENT RECORD

Please provide the information below when you correspond with us about your machine.

Purchased by _____

Installed by _____

Date of installation _____ Model number _____

Serial number _____

011808 Rev 062212

MN-1018EN

Belshaw Bros., Inc.

814 44th Street NW, Suite 103

Auburn, WA 98001 USA

Phone: 206-322-5474 • Fax: 206-322-5425

Email: service@belshaw.com • <http://www.belshaw.com>

Contents

1	Installation	1
	Unpacking the Fryer	1
	Conforming to Codes	1
	Initial Cleaning	3
	Assembling the Fryer	3
	Assembling the Cutter	4
	Adjusting the Hopper	5
	Leveling and Securing the Fryer	6
	Connecting the Fryer to the Gas Supply	7
	Moving the Fryer	7
2	Maintenance	8
	Checking the Thermostat	8
3	Troubleshooting	9
	Mark II Gas	10
	FT42 Feed Table	19
4	Electrical Components	21
	Calibrating the Thermostat	25
5	Appendix	23
	Parts List Drawing Insert Page	Insert

Preface

The Donut Robot Mark II-Gas is designed to automatically cut and fry cake donut products, and to fry yeast-raised donut products. It is not designed to cut or fry any other products. The Mark II Gas is available for LP Gas and Natural Gas in the following electrical configurations:

- 120 volts, 1 phase, 50/60 hertz

The Mark II-Gas is designed to be used on a flat, stationary table or countertop, with the operator standing opposite the control box and flue stack of the machine. The operator must work safely at all times and read this manual and follow its instructions and warnings.

The Mark II Gas produces only 71.5 dB(A) of equivalent A-weighted sound pressure at workstations. This has been determined during a dry run of the machine, using a Bruel & Kjaer sound level meter, type 2236.

Study the instructions and warnings in this manual carefully. A thorough understanding of how to install, maintain, and safely operate the Donut Robot Mark II-Gas will prevent production delays and injuries.

To use the Mark II-Gas safely, heed the following warnings and all other warnings that appear in this manual:

- Make sure the machine is secured to the work surface. Doing so will prevent the machine from moving or falling, which could cause serious injury.
- Never let water and hot shortening come in contact with each other. Moisture causes hot shortening to spatter, which may cause serious burns.
- Do not overfill the kettle with shortening. If shortening overflows the kettle, it could

cause serious burns or could cause someone to slip on the floor and be seriously injured.

- To avoid electrocution or other injury, unplug the machine before attempting any adjustment, repair, disassembly, or cleaning.
- Hot shortening can cause serious burns. Make sure that the system and the shortening are cool before attempting any adjustment, repair, disassembly, or cleaning.
- To avoid damaging the machine, never use force to assemble, disassemble, operate, clean, or maintain it.
- Be careful never to get shortening, water, or other materials on the floor. If anything does get spilled on the floor, mop it up immediately. Materials on the floor can cause people to slip or fall, resulting in serious injury or loss of life.
- To prevent unintentional startup and possible fire, unplug the machine if there is a local power outage. When the power is restored, it is safe to plug the machine in again.
- To avoid fire and personal injury, always shut the machine down completely and wait at least five minutes before igniting the pilot again.
- To avoid electrocution, make sure all electrical cords are not frayed or cracked and they do not pass through any water or shortening.
- Make sure that all electrical cords are routed so that no one will trip over them.
- To avoid serious injury or death, always keep the fryer area free and clear from combustible materials.

Unpacking the Fryer

Before you unpack and install the fryer, you should first select a workstation. The workstation should allow at least 2⁷/₅ cm clearance between the machine and all construction, whether combustible or noncombustible. To provide for proper operation and servicing, you should allow 2 ft/0.6 m clearance at the outfeed end of the fryer.

In a prominent location, post instructions to be followed in the event the user smells gas. Obtain this information by consulting your local gas supplier.

FOR YOUR SAFETY

Do not store or use gasoline or other flammable vapors or liquids in the vicinity of this or any other appliance.

WARNING

Improper installation, adjustment, alteration, service or maintenance can cause property damage, injury or death. Read the installation, operating and maintenance instructions thoroughly before installing or servicing this equipment.

Conforming to Codes

The installation of this fryer must conform with local codes, or in the absence of local codes, with the National Fuel Gas Code (ANSI Z223.1-1988), with the Natural Gas Installation Code (CAN/CGA-B149.1), or with the Propane

Installation Code (CAN/CGA-B149.2), including:

- The fryer and its individual shutoff valve must be disconnected from the gas supply piping system during any pressure testing of that system at test pressures in excess of 1/2 psig (3.45 kPa).
- The fryer must be isolated from the gas supply piping system by closing its individual manual shutoff valve during any pressure testing of the gas supply piping system at test pressures equal to or less than 1/2 psig (3.45 kPa).

The fryer, when installed, must be electrically grounded in accordance with local codes, or in the absence of local codes, with the National Electrical Code, ANSI/NFPA 70, or with the Canadian Electrical Code, CSA C22.1, as applicable.

WARNING

Electrical Grounding Instructions

This appliance is equipped with a three-prong (grounding) plug for your protection against shock hazard and should be plugged directly into a properly grounded three-prong receptacle. Do not cut or remove the grounding prong from this plug.

After unpacking, you should also be familiar with the major parts of your Donut Robot® Mark II-Gas. To help familiarize you with these parts, please study the photograph below.

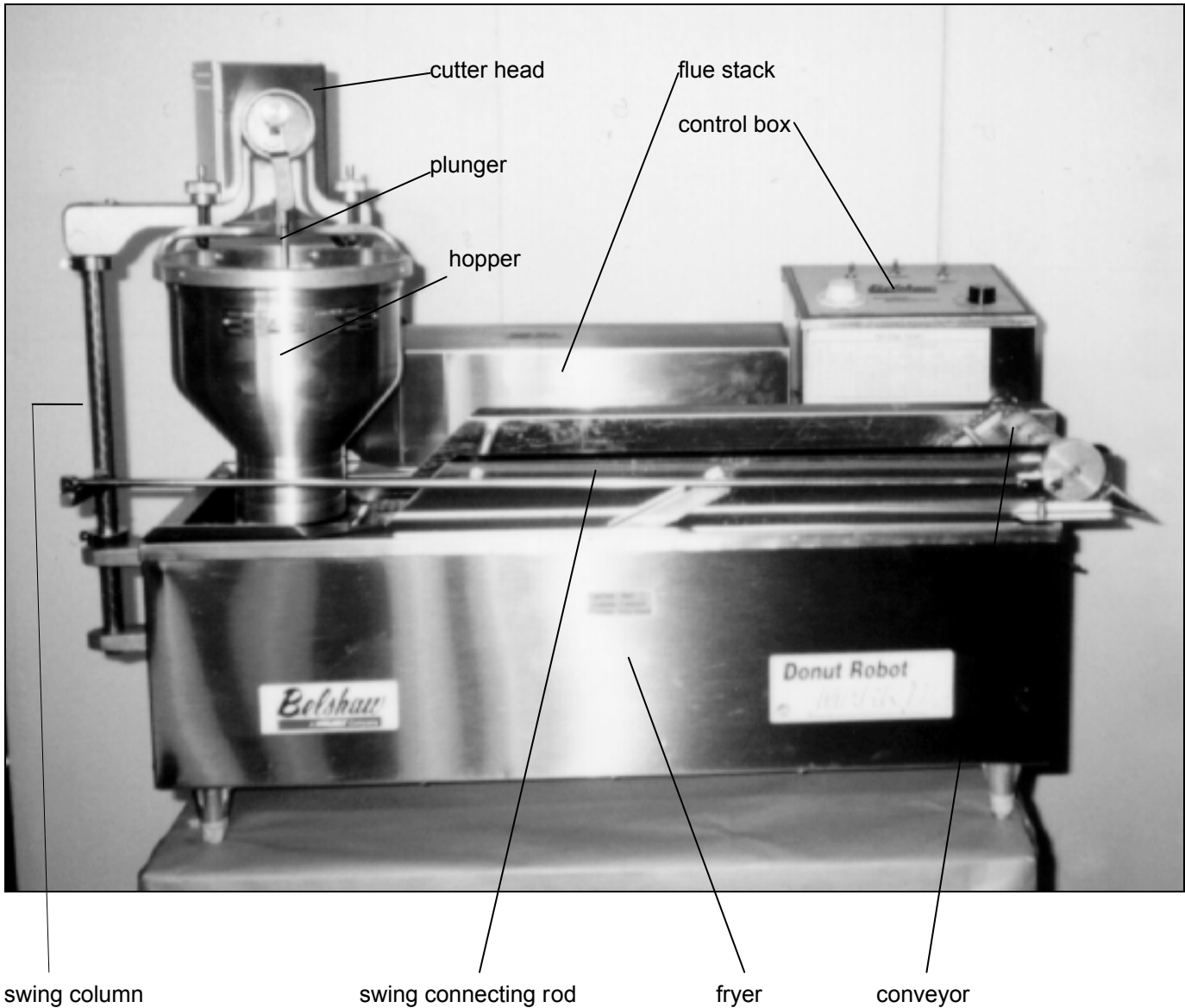

Figure 1-1. Donut Robot Mark II-Gas, Front View.

To unpack the Donut Robot® Mark II-Gas and transport it to the workstation, see the second page of this manual.

Initial Cleaning

Thoroughly clean your Donut Robot Mark II-Gas before using it. Refer to Section 3, "Cleaning," for cleaning instructions.

WARNING

To avoid electrocuting yourself or damaging the machine, never allow water, steam, cleaning solution, or other liquid to enter the cutter head or the control box.

WARNING

Never let water and hot shortening come in contact with each other. Moisture causes hot shortening to spatter, which may cause serious injury. Prior to use, make sure the kettle and any other parts you have washed are dry.

Assembling the Fryer

1. Place the fryer case on a flat, stationary surface.
2. Screw the fryer's legs in as far as they will go.
3. Set the kettle into the fryer case. The end of the kettle that has the locating pin must be placed at the outfeed end of the fryer case. The lip of the kettle should fit securely over the edge of the case.
4. Install the control box as follows:
 - a. Align the holes in the control box mounting flanges with the holes in the mounting brackets.
 - b. Slide the bolts through the holes.
 - c. Tighten the nuts onto the bolts.
5. Lower the control box assembly into position so the thermostat bulb bracket rests on or very near the bottom of the kettle.

6. Install the conveyor assembly as follows:
 - a. Hold the conveyor at the angle shown in Figure 1-2 and slide the conveyor drive coupling over the main drive shaft coupling. The conveyor coupling has a notch in it. Turn the conveyor coupling until the head of the socket head screw in the drive coupling can slide into this notch. (See Figure 1-2.)
 - b. Lower the front side of the conveyor assembly so the hole in the conveyor flange fits over the locating pin on the lip of the kettle.

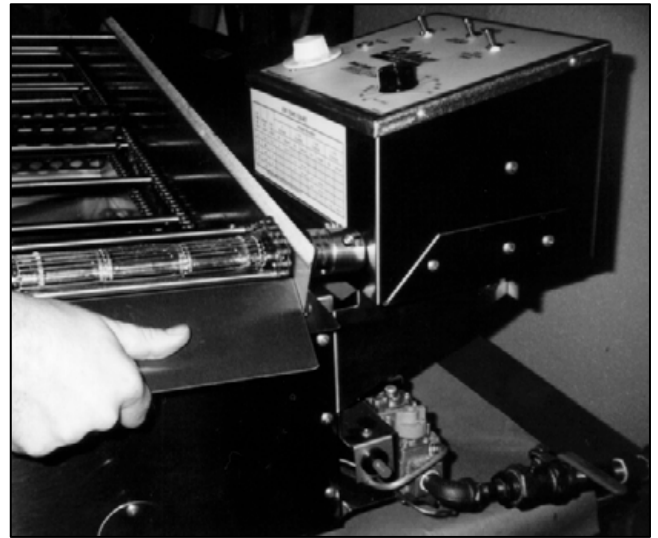

Figure 1-2. Joining the Couplings.

If you are preparing to make yeast-raised donuts, skip steps 7 and 8 and proceed to step 9.

7. Insert the swing column into the swing column mounting bracket. Make sure the plastic spacer washer is on the swing column between the set collar and the swing column mounting bracket. See Figure 1-3.



Figure 1-3. Inserting the Swing Column.

8. Connect the swing connecting rod to the throw arm of the swing column. A locating pin on the swing connecting rod rests in a hole in the throw arm. See Figure 1-4.



Figure 1-4. Connecting the Swing Connecting Rod.

9. Be sure your power source matches the specifications on the machine. Connect the machine to the power source.
10. Turn on the conveyor only and check to see that it operates smoothly. The power switch for the conveyor drive is on the control box.

Assembling the Cutter

Read this section only if you are preparing to make cake donuts.

1. Set the cutter head assembly onto the swing column. See Figure 1-5.

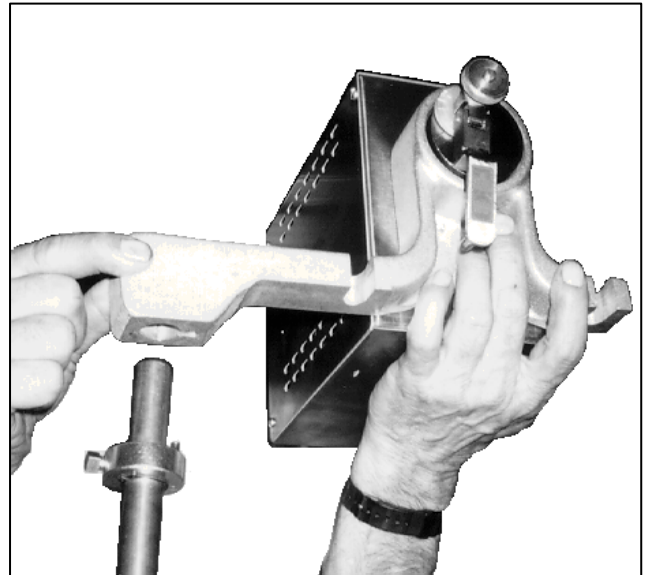

Figure 1-5. Mounting the Cutter Head Assembly.

2. Mount the hopper by sliding the two mounting studs on the hopper arch into the notches on the bearing strut. Secure the hopper with the thumb nuts. See Figure 1-6.

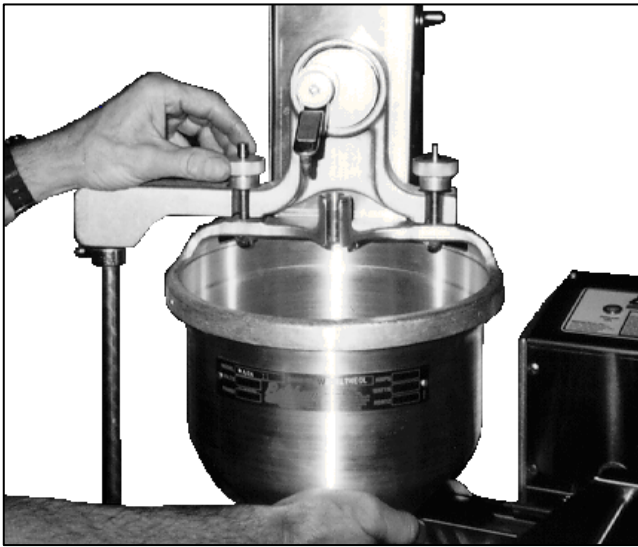

Figure 1-6. Mounting the Hopper.



Figure 1-7. Installing the Plunger.

3. Install the plunger as follows:
 - a. Pull the plunger connecting-rod up and out of the way.
 - b. Put the narrow part of the plunger's center rod through the slot in the center of the hopper arch.
 - c. Lower the plunger until the wider part at the top of the center rod enters the round opening in the hopper arch and the plunger's piston just enters the hopper cylinder.
 - d. Lower the connecting rod and insert the pin into the hole near the top of the plunger center rod. See Figure 1-7.

4. Plug the power cord from the cutter head assembly into the outlet on the back of the control box.
5. Test the cutter head to ensure that it is operating properly. Turn it on using the prime switch on the cutter head. The cutter should run continuously. Turn off the cutter.

Adjusting the Hopper

Read this section only if you are preparing to make cake donuts.

WARNING

To avoid injury, always disconnect the machine from the power source before making adjustments.

1. The bottom of the hopper should be 1" / 2.5 cm above the flight bars. To set the height of the hopper:
 - a. Hold the cutter and the hopper from below.
 - b. Loosen the set screw in the lower set collar on the swing column.
 - c. Raise or lower the swing column as needed.

- d. Tighten the set screw. See Figure 1-8.

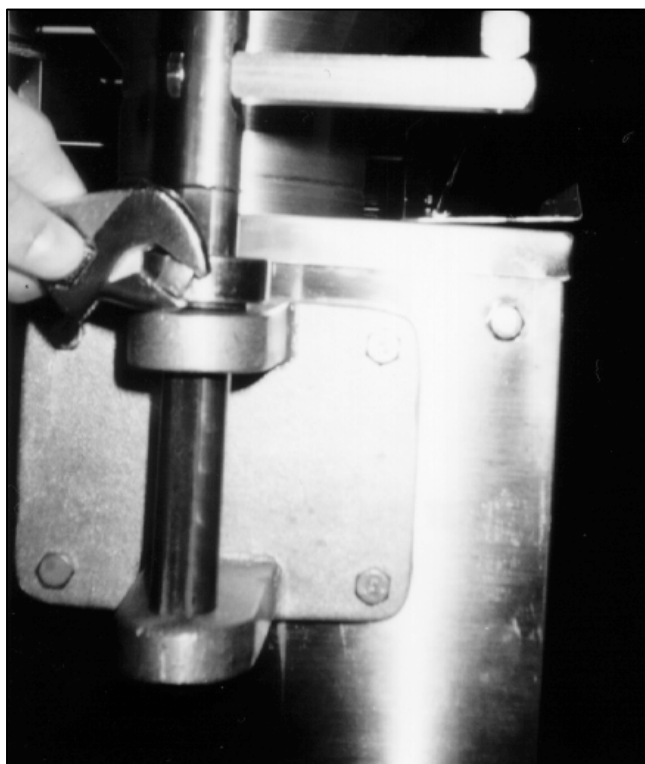

Figure 1-8. Adjusting the Height of the Hopper.

2. As the hopper swings back and forth over the kettle, the hopper cylinder should stop the same distance away from either side of the kettle at each end of the swing.

To check the swing of the hopper, turn on the conveyor. If you need to center the swing of the hopper, follow these steps:

- a. Turn off the conveyor.
- b. Loosen the set screws in the upper set collar.
- c. Swivel the bearing strut as needed.
- d. Tighten the set screws. See Figure 1-9.



Figure 1-9. Adjusting the Swing of the Hopper.

- e. Double-check the swing of the hopper by turning on the conveyor. Then turn off the conveyor.

Leveling and Securing the Fryer

Check to see if the fryer is level. If it is not, adjust the heights of the legs. Be sure that all six legs rest on the work surface when the fryer is level.

The fryer must be restrained to prevent it from tipping over and splashing hot liquid on the operator. Therefore, you must bolt the fryer to the work surface as follows:

1. There are brackets on the ends of the fryer case. Each has a hole in it. Mark the locations of the holes on the work surface.
2. Drill holes through the work surface.
3. Insert bolts through the holes.
4. Tighten nuts onto the bolts to ensure that the Donut Robot will not move.

Connecting the Fryer to the Gas Supply

1. Ask your local gas company to advise you on the size of pipe and gas meter you should use.
2. Connect the fryer to the building's gas supply.
3. Seal all threaded joints between gas pipes with pipe joint compound. You must use a compound that resists the action of liquefied petroleum (LP) gases.
4. Bleed the gas lines of all air.
5. Check all gas connections and fittings for leaks using a gas leak detector, a soap solution, or a similar substance. When such a substance is applied to connections and fittings, bubbles indicate gas leaks.

Moving the Fryer

If you ever want to move the fryer to a different workstation, follow this procedure:

1. Turn off the machine and disconnect it from the power source. Unplug the cutter head power cord.
2. Turn off the gas supply. Disconnect the machine from the gas supply.
3. Allow the machine and the shortening to cool.

WARNING
Do not touch hot shortening. It can cause serious burns.

4. Remove and set aside the plunger, the hopper, and the cutter head, in that order.
5. Disconnect the swing connecting rod.
6. Remove the shortening from the fryer as explained in "Removing the Shortening" in Section 2 of the Operator's Manual.

7. To avoid dropping the machine or getting shortening on the floor, wipe excess shortening off of the fryer and the conveyor.

WARNING
Thoroughly clean and dry the floor if shortening is spilled. Materials on the floor can cause people to slip or fall, resulting in serious injury or loss of life.

8. Set aside the conveyor.
9. Remove the nuts and bolts that hold the control box in place. Remove the control box from the fryer.
10. To prevent tripping, coil the power cord. Move the control box to the new work station.
11. Move the fryer to its new location.
12. Install the control box.
13. Move and install the conveyor.
14. Move and install the swing column. Connect the swing connecting rod.
15. To prevent tripping, coil the cutter head power cord. Move and install the cutter head.
16. Move and install the hopper and the plunger.
17. Level and secure the fryer.
18. Connect the fryer to the building's gas supply, and seal all pipe joints with joint compound.

Checking the Thermostat

If the quality of your product decreases, check the accuracy of the thermostat. Heat some shortening in the fryer, measure the temperature of the shortening using a thermometer you know to be accurate, and compare this reading to the thermostat setting. It is important that you put the thermometer in the top 1”/2.5 cm or so of shortening, because this is where the donuts fry, and this is where the temperature should be consistent. If you need to calibrate the thermostat, consult Section 4, “Electrical Components.”

If you ever want to test the continuity of the thermostat or any of the switches on your Donut Robot, refer to Section 4, “Electrical Components.”

3

Troubleshooting

This section is designed as an aid in troubleshooting, not as a substitute for a qualified technician. You may encounter a problem with your Donut Robot that is not covered in this section, or you may try the remedies suggested here and find that they do not correct the problem. In either case, feel free to call Belshaw Bros. at (206)322-5474. One of our customer support representatives will be happy to help you.

CAUTION

If you perform repairs yourself or have them performed by anyone other than Belshaw Bros. or a service technician authorized by Belshaw Bros., you do so at your own risk.

If your Donut Robot becomes badly worn or seriously out of adjustment, send it to our factory for complete rebuild and repair service. Return your machine, freight prepaid, with your instructions for service, your phone number, and the name of the person for us to contact when we have made a cost estimate. In most cases, the machine can be shipped back, freight collect, within five days.

Ship machines in need of servicing to:

Belshaw Bros., Inc.
814 44th street NW, Suite 103
Auburn, WA 98001 USA

If you need a replacement part, use the parts lists and assembly drawings in the Appendix to determine the part number and description, or call Belshaw for help. When you order the part, please specify the following:

- The model name of the machine.

- The serial number of the machine.
- The voltage and hertz of the machine.
- The part number.
- The part description, including the size, if applicable.
- The quantity desired.

Following is a troubleshooting chart to help you identify and solve some basic problems. See also:

- Section 5 in the Operator's Manual, "Donut-Making Helps," for additional information regarding baking mixes, temperature, and fry time.
- The wiring diagram in the back of this manual.

WARNING

To avoid being burned, electrocuted, or otherwise injured, unplug the machine and allow it to cool before disassembling, repairing, or wiring.

Mark II-Gas

THE DONUTS BALL OR BLISTER.	
Possible Causes	What To Do
The dough is too cold.	See Section 5 of the Operator's Manual, "Donut-Making Helps."
The shortening is too hot.	Decrease the temperature setting.
The dough is over mixed.	Review the mixing procedure.
The donuts are too large.	Adjust the dial on the cutter head to produce smaller donuts.
The shortening is old or contaminated.	WARNING
	To avoid being burned, turn off the machine and allow the shortening to cool.
	Replace the bad shortening with fresh shortening.
THE DONUTS ARE OVERCOOKED.	
Possible Causes	What To Do
The shortening is too hot.	Decrease the temperature setting. The temperature setting should never exceed 375°F/191°C.
The conveyor is moving too slowly.	Increase the speed of the conveyor.
The thermostat reads inaccurately.	Calibrate the thermostat.
THE DONUTS ARE UNDERCOOKED.	
Possible Causes	What To Do
The shortening is not hot enough.	Increase the temperature setting.
The conveyor is moving too quickly.	Decrease the speed of the conveyor.
The dough is too cold.	See Section 5 of the Operator's Manual, "Donut-Making Helps."
The dough has not had enough floor time.	See Section 5 of the Operator's Manual, "Donut-Making Helps."
The thermostat reads inaccurately.	Calibrate the thermostat.

THE DONUTS ARE SHAPED IMPERFECTLY.	
Possible Causes	What To Do
The shortening level is too low.	Add shortening to reach the proper level.
	WARNING
	To avoid being burned or otherwise injured, before doing either of the following, turn off the machine and allow the shortening to cool.
The hopper is too far above the shortening.	Lower the hopper to 1”/2.5 cm above the shortening.
The drop plate is out of position.	Reposition the drop plate.
The tip of the cylinder is dirty.	WARNING
	To avoid injury, turn off the machine and remove the hopper.
	Clean the cylinder.
The tip of the cylinder is nicked.	Replace the hopper.
The size-selection dial is not tightened.	Tighten the thumb nut.
The dough is over mixed.	Review the mixing procedure.
THE CUTTER SWING COLUMN CHATTERS.	
Possible Causes	What To Do
	WARNING
	To avoid injury, before doing either of the following, turn off the machine.
The nylon thrust washer is missing.	Install the nylon thrust washer between the swing column bracket and the set collar.
There is not enough lubrication between the swing column and the swing column mounting bracket.	Lubricate the upper and lower legs of the bracket with SAE 30 machine oil.

THE CONVEYOR BITES THE DONUTS.	
Possible Causes	What To Do
The donuts are not cooking enough.	See “The donuts are undercooked” above.
The shortening level is too low.	Add shortening to reach the proper level.
	WARNING
	Before doing any of the following, turn off the machine and allow the shortening to cool.
The turner is bent or packed with cooked food particles.	Straighten and/or clean the turner.
The cam weight is sticking due to the accumulation of varnish.	Clean to remove the cooked-on varnish.
The fryer is not level.	Level the fryer.
THE CUTTER OPERATES CONTINUOUSLY.	
Possible Causes	What To Do
	WARNING
	To avoid being burned, electrocuted, or otherwise injured, before doing any of the following, turn off the machine, allow the shortening to cool, and disconnect the machine from the power source.
One of the microswitches is defective. (There are three microswitches in the conveyor drive assembly and one microswitch in the cutter head.)	For help in testing the microswitches, refer to Section 4, “Electrical Components.” Replace any defective microswitches.
Something is interfering with the nylon brake dog in the cutter head.	Clear away the cause of the interference.
The brake spring in the cutter head is weak or broken.	Replace the spring.

THE DONUTS DROP AT THE WRONG TIME.	
Possible Cause	What To Do
The hopper swing is adjusted incorrectly.	WARNING
	To avoid injury, turn off the machine.
	Adjust the hopper swing. See “Adjusting the Hopper” in Section 1, “Installation.”
THE CONVEYOR IS JAMMED.	
Possible Causes	What To Do
	WARNING
	To avoid being burned or otherwise injured, before doing any of the following, turn off the machine and allow the shortening to cool.
The hopper is too low and the cutter or the hopper is catching on the flight bars.	Raise the hopper to 1”/2.5 cm above the flight bars.
Cooked food particles are wedged between a chain opening and a sprocket tooth.	Clean to remove the food particles. Clean the Donut Robot regularly and thoroughly.
The turner slot is packed with cooked food particles.	Clean to remove the food particles.
The drop plate is out of position and is interfering with the conveyor.	Reposition the drop plate.
Something is interfering with the free movement of the turner cam and cam weight.	Remove the obstruction.
The heating element is bent and is interfering with the turner.	Straighten the heating element.
The turner is out of position and is catching on a flight bar below.	Lift and move the outfeed end of the conveyor to disengage the conveyor coupling from the conveyor drive shaft. Turn the conveyor back 2-3 pockets. The turner will return to the correct position.

THE CONVEYOR IS JAMMED CONTINUED.

Possible Causes	What To Do
The conveyor drive shaft and the drive motor shaft are out of alignment.	Remove the cover of the drive assembly. Loosen the four mounting spacers so the drive assembly can be moved. Align the motor shaft with the conveyor shaft. When they are aligned, tighten the mounting spacers. Replace the cover.

THE MOTOR OVERHEATS.

Possible Causes	What To Do
The power requirements of the machine do not match the power source.	Supply the correct power as specified on the data plate.
	<p>WARNING</p> <p>To avoid being burned, electrocuted, or otherwise injured, before doing the following, turn off the machine, allow the shortening to cool, and disconnect the machine from the power source.</p>
The motor is binding.	Repair or replace the motor.
The motor is defective.	Repair or replace the motor.

THE CUTTER CUTS DOUBLE WHEN YOU HAVE SELECTED ONE CUT PER POCKET.

Possible Causes	What To Do
	<p>WARNING</p> <p>To avoid being burned, electrocuted, or otherwise injured, before doing any of the following, turn off the machine, allow the shortening to cool, and disconnect the machine from the power source.</p>
The nylon brake dog is binding on the cutter brake motor.	Loosen the brake dog. (brake dog is a flat metal gold color piece under motor that moves the white plastic lever) If the spring is missing or weak, replace it. If the brake dog is worn, replace it.

THE CUTTER CUTS DOUBLE WHEN YOU HAVE SELECTED ONE CUT PER POCKET CONTINUED.

Possible Causes	What To Do
An internal wire is interfering with the nylon brake dog.	Move the wire.
The arm on the cutter head microswitch is bent.	Bend the arm back into position or replace the microswitch.
The wires on the cutter head microswitch are reversed.	Make the correct connections.

THE CUTTER WILL NOT OPERATE, BUT THE CONVEYOR RUNS.

Possible Causes	What To Do
The cutter head power cord is not plugged in to the outlet on the back of the control box.	Connect the cutter head power cord to the correct outlet.
	WARNING
	To avoid being burned, electrocuted, or otherwise injured, before doing any of the following, turn off the machine, allow the shortening to cool, and disconnect the machine from the power source.
The set screws in the cutter head cam are loose.	Tighten the set screws.
The cutter head power cord is broken.	Repair or replace the cutter head power cord.
The cutter motor is defective.	Replace the cutter motor.
One of the microswitches is defective. (There are three microswitches in the conveyor drive assy. and one microswitch in the cutter head.)	For help in testing the microswitches, refer to Section 4, "Electrical Components." Replace any defective microswitches.
The cutter head power switch is defective.	Replace the cutter head power switch.
The circuit breaker on the back of the heater head is defective.	Replace the circuit breaker.
The cutter head assy. wiring harness is not connected.	Check the connection between the pin housing in the conveyor drive assembly and the socket housing in the heater head. Also, make sure that the pins are securely seated in the pin housing.
The cuts-per-pocket switch is defective.	Replace the cuts-per-pocket switch.

THE PILOT WILL NOT IGNITE, AND THE CONVEYOR WILL NOT RUN.

Possible Causes	What To Do
The power cord is not plugged in, or the outlet has no power.	Connect the machine to a good power source.
The gas is not turned on or the connection to gas source is loose.	Turn on gas. Reconnect to gas source.
	WARNING
	To avoid being burned, electrocuted, or otherwise injured, before doing any of the following, turn off the machine, allow the shortening to cool, and disconnect the machine from the power source.
The power cord is defective.	Replace the power cord.
The ignite sensor is dirty or broken	Clean sensor and tighten if necessary or replace sensor if broken.
The system safety lockouts.	Please follow these steps: <ol style="list-style-type: none"> 1. Close the first main valve. 2. Close the first main pilot valve gas control. 3. Set the fryer thermostat below 200°F/93°C. 4. Move the on/off switch to OFF. 5. Wait at least five minutes before trying again to light the pilot.
	WARNING
	Failure to wait at least five minutes for gas to dissipate could result in a fire or an explosion when the pilot is lit again.

THE PILOT WILL NOT IGNITE, BUT THE CONVEYOR RUNS.	
Possible Causes	What To Do
The gas is not turned on or the connection to gas source is loose.	Turn on gas. Reconnect to gas source.
The high temperature limit control switch has been tripped.	Push the red reset button on the back of the control box.
The thermostat has been calibrated incorrectly.	Recalibrate the thermostat.
	WARNING
	To avoid being burned, electrocuted, or otherwise injured, before doing any of the following, turn off the machine, allow the shortening to cool, and disconnect the machine from the power source.
The high temperature limit control is defective.	Replace the high temperature limit control.
The thermostat is defective.	Replace the thermostat.
THE GAS SYSTEM HEATS, BUT THE CONVEYOR WILL NOT RUN.	
Possible Causes	What To Do
The input voltage is incorrect.	Supply the correct power as specified on the data plate.
	WARNING
	To avoid being burned, electrocuted, or otherwise injured, before doing any of the following, turn off the machine, allow the shortening to cool, and disconnect the machine from the power source.
There is a short circuit.	Find it and repair it.
The wiring harness in the conveyor drive assembly is not connected.	Check the connection of the pin connector from the conveyor drive assembly to the socket connector in the heater head enclosure. Make sure the pins in the pin housing are securely seated in the housing.
The conveyor drive power switch is defective.	Replace the switch.
The nylon brake dog is binding on the conveyor brake motor.	If the brake dog is worn, replace it. If it is too tight, loosen it. If the spring is weak or missing, replace it.
The brake motor is defective.	Replace the brake motor.
An internal wire is interfering with the nylon brake dog.	Move the wire.
THE GAS SYSTEM HEATS, BUT THE CONVEYOR WILL NOT RUN	

CONTINUED.	
A fan blade is caught on a wire.	Move the wire.
The conveyor is jammed.	Clear the obstruction.
The couplings are not engaged.	Engage the couplings.
The conveyor drive coupling is slipping.	Tighten the two set screws.

FT42 Feed Table

THE CONVEYOR CHAINS DO NOT ADVANCE WHEN THE MAIN POWER IS ON OR WHEN THE PRIME SWITCH IS PRESSED, AND THE PILOT LIGHT DOES NOT COME ON.	
Possible Causes	What To Do
The power cord is not connected.	Plug in the power cord.
The circuit breaker for the gear box outlet on the Donut Robot's heater head is tripped.	Push the white reset button near the outlet.
	WARNING
	To avoid electric shock or other injury, before doing any of the following, unplug the machine.
The black or white wire in the power cord is broken or poorly connected.	Repair the cord and/or make the proper connection.
The fuse on the Feed Table is blown.	Replace the fuse.
The fuse for the Donut Robot's conveyor is blown.	Replace the fuse.
THE CONVEYOR CHAINS DO NOT ADVANCE WHEN THE MAIN POWER IS ON, BUT THEY DO ADVANCE WHEN THE PRIME SWITCH IS PRESSED.	
Possible Causes	What To Do
	WARNING
	To avoid electric shock or other injury, before doing any of the following, unplug the machine.
The red wire in the power cord is broken or poorly connected.	Repair the cord and/or make the proper connection.
The microswitch in the power head is defective.	Replace the microswitch.
The microswitch in the Donut Robot's signal circuit is defective.	Replace the microswitch.

THE CONVEYOR CHAINS DO NOT ADVANCE AT ALL, DO NOT ADVANCE FAR ENOUGH, OR DO NOT ADVANCE THE SAME DISTANCE DURING EACH CYCLE, BUT THE PILOT LIGHT DOES COME ON.	
Possible Cause	What To Do
	WARNING
	To avoid electric shock or other injury, before doing the following, unplug the machine.
The cam in the power head is loose.	Tighten the cam set screw.
THE CONVEYOR CHAINS ADVANCE CONTINUOUSLY WHEN THE MAIN POWER IS ON.	
Possible Causes	What To Do
	WARNING
	To avoid electric shock or other injury, before doing any of the following, unplug the machine.
The brake is defective.	Repair or replace the brake.
The cam in the power head is loose.	Tighten the cam set screw.
The microswitch in the power head is defective.	Replace the microswitch.
The microswitch in the Donut Robot's signal circuit is defective.	Replace the microswitch.
TWO ROWS OF DONUTS ARE ADVANCED DURING EACH CYCLE.	
Possible Causes	What To Do
	WARNING
	To avoid electric shock or other injury, before doing either of the following, unplug the machine.
The brake is defective.	Repair or replace the brake.
The cam in the power head is loose.	Tighten the cam set screw.

4

Electrical Components

This section explains how to check and adjust the thermostat on a Donut Robot[®] fryer. Do this if the temperature on the Temperature Control dial does not match the temperature reading taken by a reliable thermometer or temperature probe.

Adjusting the Thermostat **(“Temperature Control”)**

1. This procedure requires about 15 minutes if the fryer is hot. Do not perform this test while making donuts.
2. Have a reliable thermometer or temperature probe ready that reads up to 400°F (or 200°C).
3. If the shortening is liquid, turn on the fryer conveyor. This will circulate the heat evenly around the fryer.
4. Set the Temperature Control dial to 375°F (190°C). Allow the fryer to reach operating temperature. When the fryer reaches this point, the red light above the Temperature Control should go OFF.
5. Turn off the fryer conveyor.
6. Use thick heat resistant gloves as a precaution when performing the next step. The shortening is HOT. NEVER put your hand, fingers or other body parts under the shortening.

WARNING

NEVER touch shortening when it is hot, even with gloves on. It can cause serious burns. Avoid touching the surrounding metal parts. They are HOT.

7. CAREFULLY insert the tip of your thermometer or temperature probe approximately 1” (25mm) below the surface, close to the middle of the fryer. DO NOT touch the shortening with your hand or fingers, even with gloves on.
8. Wait for the light above the Temperature Control to change from OFF to ON. Now check the temperature on your thermometer or probe. If the Thermostat is working properly, this temperature will show 370° to 375°F (188° to 190°C).
9. If not, an adjustment is needed as follows.
10. Turn off the power to the Donut Robot[®] by disconnecting the plug, OR by turning the breaker switch at the back of the fryer to the OFF position.

WARNING

To avoid the possibility of electric shock, disconnect or turn off the power source before adjusting the thermostat.

11. Carefully lift up the Temperature Control dial with your fingers or other implement, until it comes off.



-
12. Loosen the screws that hold the Thermostat in place under the dial. (See photo above) You should NOT loosen the screws all the way, or the Thermostat might fall out.
 13. If the temperature in step 6 was MORE than 375°F (190°C), rotate the Thermostat CLOCKWISE.
 14. If the number you recorded in step 6 was LESS than 370°F (190°C), rotate the Thermostat COUNTER-CLOCKWISE.
 15. Tighten both screws again and replace the Temperature Control dial.
 16. Connect power to the Donut Robot and retest by repeating the process from Step 3 above.
 17. If you are UNABLE to rotate the Thermostat far enough to make the light come on between 370° to 375°F (188° to 190°C), you should first check your Thermometer. Get a 2nd thermometer and compare the two.
 18. If necessary, go back to Step 3 using the most accurate thermometer.
 19. If you are still UNABLE to rotate the Thermostat far enough to make the light come on between 370° to 375°F (188° to 190°C), have a qualified technician check your fryer and if necessary replace the thermostat. The part number is listed on the wiring diagram attached to your manual.

See Parts List Drawing Insert Page.