



Belshaw[®]

Open Kettle Gas Fryer

718LFG, 724FG, & 734FG

Operator's Manual

Belshaw Adamatic Bakery Group

814 44th Street NW, Suite 103

Auburn, WA 98001 USA

Phone: 800 578-2547 (Toll free USA/Canada) • (+1) 253-886-5340 (International)

Email: service@belshaw.com • www.belshaw.com

EQUIPMENT RECORD

Please provide the information below when you correspond with Belshaw about your machine.

Purchased by _____

Installed by _____

Date of Installation _____

Model number _____

Serial number _____

IN CASE OF DAMAGE TO EQUIPMENT

In case of damage to the equipment upon delivery, follow these steps immediately.

1. Inform the freight carrier. The phone number will be on the shipping receipt or label.
2. Take photographs of the equipment, both inside and outside the box or crate.
3. Do not throw away any packaging.
4. Report the damage to the distributor (or other party) from whom you bought the equipment.
5. Email your photos to the distributor (or other party) AND to Belshaw Customer Service at service@belshaw.com. Include a Belshaw Order Number in your communications. Your Order Number will begin with "CO...", followed by 6 digits) and should be marked on the box or crate.

IN CASE OF MISSING ITEMS

1. If possible, note the missing items on the delivery receipt of the freight carrier.
2. Take photographs of the entire shipment.
3. Follow steps 1 – 5 above.

0317

MN-1147EN

Belshaw Adamatic Bakery Group
814 44th Street Northwest, Suite 103
Auburn, WA 98001 USA

Phone: 800 578-2547 (Toll free USA/Canada) • (+1) 253-886-5340 (International)

E-mail: service@belshaw.com • www.belshaw.com

Contents

1	<i>Preface</i>	4
2	<i>Operation</i>	5
	Taking Safety Precautions	5
	Controls	5
	Initial Lighting	5
	Complete Shut Down	5
	Frying Donuts	5
3	<i>Cleaning</i>	8
	Removing the Shortening	8
	Washing	9
	Rinsing	10
4	<i>Donut-Making Helps</i>	11
	Tips on Making Quality Cake Donuts	11
	Temperature Conversion	12
	Calculating Correct Water Temperature	12
	Ratios of Plunger Sizes to Donut Weights	12

The 718LFG, 724FG, and 734FG Gas Fryers are designed to fry cake and yeast-raised donut products. Each must be bolted to a flat, dry floor. The operator should stand opposite the flue stack.

The operator must work safely at all times and read this manual and follow its instructions and warnings. A thorough understanding of how to install, maintain, and safely operate the fryer will prevent production delays and injuries.

Heed the following warnings and all other warnings that appear in this manual:

- Make sure the machine is bolted securely to the floor. Doing so will prevent the machine from moving, tipping, or falling, which could cause serious injury.
- Never let water and hot shortening come in contact with each other. Moisture causes hot shortening to spatter, which may cause serious burns.
- Do not overfill the kettle with shortening. If shortening overflows the kettle, it could cause serious burns or could cause someone to slip on the floor and be seriously injured.
- Hot shortening can cause serious burns. Make sure that the system and the shortening are cool before attempting any cleaning, adjustment, disassembly, or repair.
- To avoid damaging the machine, never use force to assemble, disassemble, operate, clean, or maintain it.
- Be careful never to get shortening, water, or other materials on the floor. If anything does get spilled on the floor, mop it up immediately. Materials on the

floor can cause people to slip or fall, resulting in serious injury or loss of life.

- Make sure you are aware of the following:

This product contains chemicals known to the State of California to cause birth defects or other reproductive harm. Operation, installation and servicing of this product could expose you to carbon monoxide if not adjusted properly. Inhalation of carbon monoxide is known to the State of California to cause birth defects or other reproductive harm.

Maintenance and repairs shall only be carried out by a factory representative or qualified service personnel.

- Liquid Propane fryers

Liquid propane models are designed for use with a secure commercially installed propane tank located remotely from your fryer. Do not use with a portable propane tank.

- LPG/LNG Conversion:

Contact Belshaw Brothers at 1-800-578-2547 to obtain necessary parts and instructions.

- To avoid electrocution or other injury, unplug the machine before attempting any cleaning, adjustment, disassembly, or repair.

Taking Safety Precautions

In a prominent location, post information about what to do if there is a gas leak. Make sure that all employees know what to do.

WARNING

To avoid the possibility of fire, explosion, property damage, serious burns, and even death, never store gasoline or any other flammable liquid or vapor near the fryer.

WARNING

To avoid serious injury or death, if you smell gas or suspect a gas leak, proceed as follows: 1. Turn off the gas. 2. Evacuate the building. 3. Do not touch any electrical switch or telephone until you are sure no spilled gas remains.

Controls

The gas cock knob on the gas control has three settings: Off, Pilot, and On.

Off: Prevents any gas from passing through the valve to either main or pilot burner.

Pilot: Permits gas to flow to pilot burner only (when gas cock knob is held depressed or when generator is heated sufficiently to hold valve open)

On: Permits gas to flow to both main and pilot burners when the system is functioning correctly.

Initial Lighting

This procedure is required only after a complete shut down or installation.

Light the fryer as follows:

1. Turn the thermostat knob to the OFF position. Wait five minutes.
2. Rotate the gas control knob counterclockwise to the PILOT position. Fully depress the knob and hold it down while lighting the pilot burner. Continue to hold down the knob approximately one minute. Release the knob and check to see that the pilot burner remains lit. Turn the knob to ON.
3. Turn the thermostat knob to the desired temperature to light the main burners.

Complete Shut Down

This procedure is only required before servicing.

Turn the gas control knob clockwise from the ON position to the PILOT position. Slightly depress the knob and turn to OFF position.

Frying Donuts

WARNING

To avoid serious injury or death, before you begin working, make sure that there is no combustible material in the area of the fryer.

Read each step **completely** before doing what it tells you to do.

1. Make sure the drain valve is completely closed.

- Put enough shortening in the kettle to completely cover the burner tubes, thermocouple, and high-temperature limit control probe.

Put shortening in the kettle using one of these methods:

- If you have a Belshaw Shortening Melter (EZ) attached to the fryer, use the EZ to melt shortening and transfer it to the kettle. See the EZ Melt manual.

WARNING

Hot shortening causes severe burns.

- Melt shortening in a pan on the stove and pour it into the kettle.
- Put solid shortening into the kettle, packing it tightly around the burner tubes.

WARNING

Air spaces can cause the shortening to overheat and catch on fire.

CAUTION

To avoid severe damage to the kettle, never turn on the heat unless the heat tubes are completely covered by liquid.

- Move the on/off switch to the OFF position.
- Rotate the gas control knob counterclockwise to the ON position.
- Move the on/off switch to the ON position.
The yellow pilot light near the on/off switch and the red pilot light on the fryer cabinet will both light up.
- Turn the thermostat control knob to the desired temperature. This will cause the pilot to ignite. Also, the yellow pilot light

on the fryer cabinet will light up, indicating that the thermostat is calling for heat.

If the pilot fails to ignite within a certain length of time, the gas system will go into safety lock-out. If this happens, move the on/off switch to OFF, wait at least one minute, and then move the on/off switch to ON again.

WARNING

Failure to wait at least one minute for the gas to dissipate could result in a fire or an explosion when the pilot is lighted again.

If the shortening temperature exceeds 435°F/224°C, the high-temperature limit control will break the circuit, and the electrical and gas systems will shut off.

If this happens, follow these steps to reset the system:

- Move the on/off switch to the OFF position.
 - Wait for the shortening to cool to 385°F/196°C or below. You will not be able to ignite the pilot until the shortening reaches this temperature.
 - Move the on/off switch to the ON position.
- Continue adding shortening to the kettle until it reaches the proper depth for frying. Use one of the following methods. For safety reasons, we recommend the first method, and discourage you from using any other method.
 - Use a Belshaw Shortening Melter (FM) to melt shortening and transfer it to the kettle. See the FM manual.
 - Melt shortening in a pan on the stove and pour it into the kettle.
 - Very carefully put solid shortening into the kettle.

WARNING

To avoid serious burns, be very careful not to splatter hot shortening when you add shortening to the kettle.

Because shortening expands as it increases in temperature, put shortening in the kettle gradually. Let the shortening in the kettle heat up before you add more.

8. Wait for the shortening to reach the desired temperature.

WARNING

To avoid serious burns, when the fryer is operating, do not touch the flue, exhaust manifold, stacks, gas burners, or any part of the fryer that is in contact with hot shortening. Keep clear from the area above the flue outlet.

9. If you are frying cake or French donuts, move the cutter into place over the fryer. Refer to the cutter manual for complete installation and operation instructions.

CAUTION

To avoid damaging the machine, do not operate the conveyor until all the shortening has melted.

10. Continue supplying shortening to the kettle as required. Keep the kettle filled up to the "Oil Level" marks on the side.
11. When you are done frying donuts, move the on/off switch to the OFF position.

For your safety, observe the following warnings throughout the entire cleaning process.

WARNING

Thoroughly clean and dry the floor if shortening, water, or other materials are spilled. Materials spilled on the floor can cause serious injury or loss of life.

WARNING

To avoid electrocuting yourself or damaging the machine, never allow water, steam, shortening, cleaning solution, or any other liquid to enter the electrical box.

WARNING

To avoid serious burns while cleaning, do not touch the flue, exhaust manifold, stacks, gas burners, or any part of the fryer that is in contact with hot liquids.

There are four basic steps to cleaning the fryer: removing the shortening, washing, rinsing, and drying. You must perform all four steps and perform them in the order listed.

Removing the Shortening

1. Let the shortening cool to 100°F/38°C.
2. Place a Belshaw Shortening Filter or a large metal container under the drain valve of the fryer.

WARNING

Do not use a plastic container. If the shortening is not cool enough, the container will melt, possibly causing you to be burned, and causing shortening to get on the floor.

3. Open the drain valve by turning the drain valve extension knob on the side of the fryer cabinet. Allow all the shortening to drain into the Shortening Filter or metal container.
4. If you are using a metal container, watch it to make sure the shortening does not overflow. If the container becomes full, close the drain valve, put another metal container under the drain valve, and open the drain valve again.

WARNING

Do not allow the shortening to overflow the containers. Shortening will get on the floor, and if the shortening is not cool enough, you may be burned.

WARNING

Thoroughly clean and dry the floor if shortening is spilled. Shortening on the floor can cause serious injury or loss of life.

- Using a non-abrasive, non-metallic spatula, scrape the sediment and any remaining shortening into the drain valve.

WARNING

To avoid fire, serious injury, and equipment damage, do not attempt to burn carbon off of the heat tubes.

- Close the drain valve.
- If your fryer has a Belshaw Shortening Melter (FM) connected to it, install the plug into the reservoir nipple.

Washing

- Pour hot water into the kettle, up to the normal level of the shortening. Add trisodium phosphate or another appropriate cleaner.

CAUTION

To avoid severe damage to the kettle, never turn on the heat unless the heat tubes are completely covered by liquid.

- Connect the fryer to the power source. Move the on/off switch to ON. Set the temperature control to 200°F/93°C. Keep the cleaning solution at this temperature for 15-20 minutes.
- Scrub the soiled parts while the solution is hot. Do not use any abrasive cleaners or scrapers.

WARNING

To avoid being burned, be very careful as you work with hot cleaning solution. Never put your hands in the solution. Wear gloves and long sleeves in case any solution splashes.

- Turn off the fryer. Turn off the pilot light. Allow the cleaning solution to cool to 100°F/38°C.
- Place a large metal container under the drain valve.

WARNING

Do not use plastic containers. If the cleaning solution is not cool enough, the containers will melt; possibly causing you to be burned, and causing cleaning solution to get on the floor.

- Open the drain valve and allow the cleaning solution to drain into the container.
- Watch the container to make sure the cleaning solution does not overflow. If the container becomes full, close the drain valve, put another large metal container under the drain valve, and open the drain valve again.

WARNING

Do not allow the cleaning solution to overflow the containers. Cleaning solution will get on the floor, and if the solution is not cool enough, you may be burned.

- When the draining is complete, close the drain valve.
- Carefully carry the container(s) to the sink and slowly pour the solution into the sink.

WARNING

Thoroughly clean and dry the floor if cleaning solution is spilled. Liquid on the floor can cause serious injury or loss of life.

Rinsing

1. Pour clean water into the kettle, up to the normal level of the shortening. If the cleaner you have used requires that you add a neutralizer, do so now.

CAUTION

To avoid severe damage to the kettle, never turn on the heat unless the heat tubes are completely covered by liquid.

2. Start up the fryer. Set the temperature controls at 200°F/93°C. Leave the water at this temperature for 5-10 minutes.
3. Shut off the fryer. Allow the water to cool to 100°F/38°C.
4. Place a large metal container under the drain valve.

WARNING

Do not use plastic containers. If the water is not cool enough, the containers will melt; possibly causing you to be burned, and causing cleaning solution to get on the floor.

5. Open the drain valve and allow the water to drain into the container.
6. Watch the container to make sure the water does not overflow the container. If the container becomes full, close the drain valve, put another large metal container under the drain valve, and open the drain valve again.

WARNING

Do not allow the water to overflow the containers. Water will get on the floor, and if the water is not cool enough, you may be burned.

7. When the draining is complete, close the drain valve.
8. Carefully carry the container(s) to the sink and slowly pour the water into the sink.

WARNING

Thoroughly clean and dry the floor if water is spilled. Water on the floor can cause serious injury or loss of life.

9. Dry the kettle, drain valve, and burner tubes thoroughly. Make sure there is no water in the drain tube.

WARNING

Dry all parts of the fryer thoroughly. Failure to dry the fryer and kettle completely will cause an eruption. Shortening will overflow the sides of the fryer and may result in fire, injury, or death.

4

Donut-Making Helps

Tips on Making Quality Cake Donuts

- Use the correct batter temperature.
In general, the correct batter temperature is 75°-80°F/24°-27°C. Check the mix manufacturer's instructions, as the recommended temperature range may vary.
If the batter is too warm, the donuts will lack volume and may "ring out" or be misshapen. If the batter is too cold, the donuts will stay under the shortening too long, fry too slowly, and crack open or ball up. They may also absorb excess shortening and lose volume.
- Use the correct floor time.
A floor time of 10 minutes between mixing and cutting allows the baking powder to react with the water. This helps the donuts attain the proper volume and absorb the proper amount of shortening.
If the floor time exceeds 30 minutes, the mix will gas off, the donuts will lose volume and shape and will absorb too much shortening.
- Use the correct frying temperature.
The correct shortening temperature for frying is 370°-380°F/188°-193°C.
If the shortening is too hot, the donuts will fry too quickly on the outside and will lose volume. The donuts may also become dense inside.

If the shortening is too cold, the donuts will spread too rapidly, will form large rings, will tend to crack open, will be too light in appearance, and will absorb too much shortening.

- Maintain the proper shortening level. We recommend a distance of 1 1/4" between the cutter and the shortening.

If the shortening is too deep, the donuts may not turn over when they reach the turner, causing them to cook unevenly.

If the shortening is too shallow (too far below the cutter), the donuts may not drop flat, may turn over while submerging and surfacing, and may become irregular, cracked, or rough-cruled.

- Ensure that the donuts absorb the right amount of shortening.

Donuts should absorb 1-1/2 to 3 oz/42 to 85 g of shortening per dozen, depending on their weight. You can achieve proper absorption by following tips 1-3.

- If the donuts do not absorb enough shortening, they will not keep well.

If they absorb too much shortening, they will lose volume and may become misshapen. If this happens, follow tips 1-3, mix the batter a little longer than usual, turn the donuts as soon as they become golden brown, and turn the donuts only once.

Temperature Conversion

To convert temperatures from Fahrenheit to Celsius:

- Subtract 32 from °F and divide the result by 1.8.

Example: $(212^{\circ}\text{F}-32)/1.8 = 100^{\circ}\text{C}$

To convert temperatures from Celsius to Fahrenheit:

- Multiply °C by 1.8 and add 32 to the result.

Example: $(100^{\circ}\text{C} \times 1.8) + 32 = 212^{\circ}\text{F}$

°F	°C	°F	°C
55	12.8	76	24.4
56	13.3	77	25.0
57	13.9	78	25.6
58	14.4	79	26.1
59	15.0	80	26.7
60	15.6	325	162.8
61	16.1	330	165.6
62	16.7	335	168.3
63	17.2	340	171.1
64	17.8	345	173.9
65	18.3	350	176.7
66	18.9	355	179.4
67	19.4	360	182.2
68	20.0	365	185.0
69	20.6	370	187.8
70	21.2	375	190.6
71	21.7	380	193.3
72	22.2	385	196.1
73	22.8	390	198.9
74	23.3	395	201.7
75	23.9	400	204.4

Calculating Correct Water Temperature

The following is an example of how to calculate the correct water temperature to use. You must use your own room temperature, dry mix temperature, and desired batter temperature.

	°F	°C
Room temperature	72	22.2
Dry mix temperature	<u>+70</u>	<u>+21.1</u>
Total A	142	43.3
Desired batter temperature	75	23.9
	<u>x3</u>	<u>x3</u>
Total B	225	71.7
Total B	225	71.7
-Total A	<u>-142</u>	<u>-43.3</u>
Desired water temp. for cake donuts	83°F	28.4°C

Ratios of Plunger Sizes to Donut Weights

The weights given are for donuts without icings or other toppings. They are provided for reference only, as weights vary according to the density of the batter.

PLUNGER SIZE	DONUT WEIGHT PER DOZEN
1"	5-8 oz/142-227 g
1 7/16"	10-17 oz/283-482 g
1 9/16"	14-21 oz/397-595 g
1 13/16"	19-23 oz/539-652 g



Belshaw®

Open Kettle Gas Fryer

718LFG, 724FG, & 734FG

Technical Supplement

Belshaw Adamatic Bakery Group

814 44th Street NW, Suite 103

Auburn, WA 98001 USA

Phone: 800 578-2547 (Toll free USA/Canada) • (+1) 253-886-5340 (International)

Email: service@belshaw.com • www.belshaw.com

EQUIPMENT RECORD

Please provide the information below when you correspond with Belshaw about your machine.

Purchased by _____

Installed by _____

Date of Installation _____

Model number _____

Serial number _____

IN CASE OF DAMAGE TO EQUIPMENT

In case of damage to the equipment upon delivery, follow these steps immediately.

1. Inform the freight carrier. The phone number will be on the shipping receipt or label.
2. Take photographs of the equipment, both inside and outside the box or crate.
3. Do not throw away any packaging.
4. Report the damage to the distributor (or other party) from whom you bought the equipment.
5. Email your photos to the distributor (or other party) AND to Belshaw Customer Service at service@belshaw.com. Include a Belshaw Order Number in your communications. Your Order Number will begin with "CO...", followed by 6 digits) and should be marked on the box or crate.

IN CASE OF MISSING ITEMS

1. If possible, note the missing items on the delivery receipt of the freight carrier.
2. Take photographs of the entire shipment.
3. Follow steps 1 – 5 above.

0317

MN-1148EN

Belshaw Adamatic Bakery Group
814 44th Street Northwest, Suite 103
Auburn, WA 98001 USA

Phone: 800 578-2547 (Toll free USA/Canada) • (+1) 253-886-5340 (International)

E-mail: service@belshaw.com • www.belshaw.com

Contents

1	<i>Preface</i>	4
2	<i>Installation</i>	5
	Conforming to Codes	5
	Selecting a Workstation	5
	Unpacking the Fryer	5
	Initial Cleaning	6
	Assembling the Fryer	6
	Installing the Fryer	7
	Ventilation	8
	Moving the Fryer	8
	Assembling the Frying Screen Handles	8
3	<i>Troubleshooting</i>	10
4	<i>Additional Information</i>	11
	Listing and Installation Standards	11
	Robertshaw Type K and S Electric Thermostats	13
	SB-168 Submerger Kit Installation	15
5	<i>Parts List</i>	17
	See Parts List Drawing Insert Page.	17

The 718LFG, 724FG, and 734FG Gas Fryers are designed to fry cake and yeast-raised donut products. Each must be bolted to a flat, dry floor. The operator should stand opposite the flue stack.

The operator must work safely at all times and read this manual and follow its instructions and warnings. A thorough understanding of how to install, maintain, and safely operate the fryer will prevent production delays and injuries.

Heed the following warnings and all other warnings that appear in this manual:

- Make sure the machine is bolted securely to the floor. Doing so will prevent the machine from moving, tipping, or falling, which could cause serious injury.
- Never let water and hot shortening come in contact with each other. Moisture causes hot shortening to spatter, which may cause serious burns.
- Do not overfill the kettle with shortening. If shortening overflows the kettle, it could cause serious burns or could cause someone to slip on the floor and be seriously injured.
- Hot shortening can cause serious burns. Make sure that the system and the shortening are cool before attempting any cleaning, adjustment, disassembly, or repair.
- To avoid damaging the machine, never use force to assemble, disassemble, operate, clean, or maintain it.
- Be careful never to get shortening, water, or other materials on the floor. If anything does get spilled on the floor,

mop it up immediately. Materials on the floor can cause people to slip or fall, resulting in serious injury or loss of life.

- Make sure you are aware of the following:

This product contains chemicals known to the State of California to cause birth defects or other reproductive harm. Operation, installation and servicing of this product could expose you to carbon monoxide if not adjusted properly. Inhalation of carbon monoxide is known to the State of California to cause birth defects or other reproductive harm.

Maintenance and repairs shall only be carried out by a factory representative or qualified service personnel.

- Liquid Propane fryers

Liquid propane models are designed for use with a secure commercially installed propane tank located remotely from your fryer. Do not use with a portable propane tank.

- LPG/LNG Conversion:

Contact Belshaw Brothers at 1-800-578-2547 to obtain necessary parts and instructions.

- To avoid electrocution or other injury, unplug the machine before attempting any cleaning, adjustment, disassembly, or repair.

In a prominent location, post instructions to be followed in the event the user smells gas. Obtain this information by consulting your local gas supplier.

FOR YOUR SAFETY

Do not store or use gasoline or other flammable vapors or liquids in the vicinity of this or any other appliance.

WARNING

Improper installation, adjustment, alteration, service or maintenance can cause property damage, injury or death. Read the installation, operating and maintenance instructions thoroughly before installing or servicing this equipment.

Conforming to Codes

The installation of this fryer must conform with local codes, or in the absence of local codes, with the National Fuel Gas Code (ANSI Z223.1-1992), with the Natural Gas Installation Code (CAN/CGA-B149.1), or with the Propane Installation Code (CAN/CGA-B149.2), including:

- The fryer and its individual shutoff valve must be disconnected from the gas supply piping system during any pressure testing of that system at test pressures in excess of 1/2 psig (3.45 kPa).

- The fryer must be isolated from the gas supply piping system by closing its individual manual shutoff valve during any pressure testing of the gas supply piping system at test pressures equal to or less than 1/2 psig (3.45 kPa).
- Propane fueled fryers must be used with a secure commercially installed propane tank located remotely from your fryer. Do not use with a portable propane tank

Selecting a Workstation

The room in which the fryer is to be used should provide enough air for combustion. A ventilation hood with grease filters must be used with the fryer. The hood must be installed and operated in conformance with all applicable fire codes and emissions standards.

The workstation should allow at least 2”/5 cm clearance between the machine and all construction, whether combustible or noncombustible. In addition, it should allow access to the rear of the fryer for cleaning and servicing.

Unpacking the Fryer

1. Use a fork lift to transport the shipping crate to the work station.
2. Break down the shipping crate.
3. Remove all the packing materials from the fryer. These include foam, tape, brown paper, plastic, and white protective coating.
4. Wash the fryer with soapy water. Rinse and wipe dry.

4. Position the fryer to allow sufficient space on either end of the machine for any equipment you plan to use with it.

Initial Cleaning

Clean your fryer before using it. Wipe the inside of the kettle with a soft, damp cloth. Dry the kettle thoroughly.

WARNING

To avoid electrocuting yourself or damaging the machine, never allow water, steam, cleaning solution, or other liquid to enter the electrical box.

WARNING

Never let water and hot shortening come in contact with each other. Moisture causes hot shortening to spatter, which may cause serious injury. Prior to use, make sure the kettle and any other parts you have washed are dry.

Assembling the Fryer

1. Install the flue stack as follows:
 - a. Slide the flange on the bottom of the flue stack underneath the retaining strip on the flue base. The mounting holes must line up. (See Figure 1-1.)
 - b. Fasten the flue stack to the flue base using the two pan-head sheet metal screws provided.
2. Attach the heat shield to the splash shield as follows:
 - a. Slide the flanges on the sides of the heat shield under the bent edges of the splash shield. The mounting holes must line up.
 - b. Fasten the heat shield to the splash shield using the 10-24 x 3/8" hex-head screws, lockwashers, and nuts provided. The screws go through the front of the splash shield; the lockwashers and nuts go on the back of the heat shield.
3. Put the heat shield and splash shield on the fryer. They slide over the flue stack, and the back of the kettle slides between the heat shield and the splash shield. The mounting holes in the heat shield and the fryer cabinet must line up. See Figure 1-2.

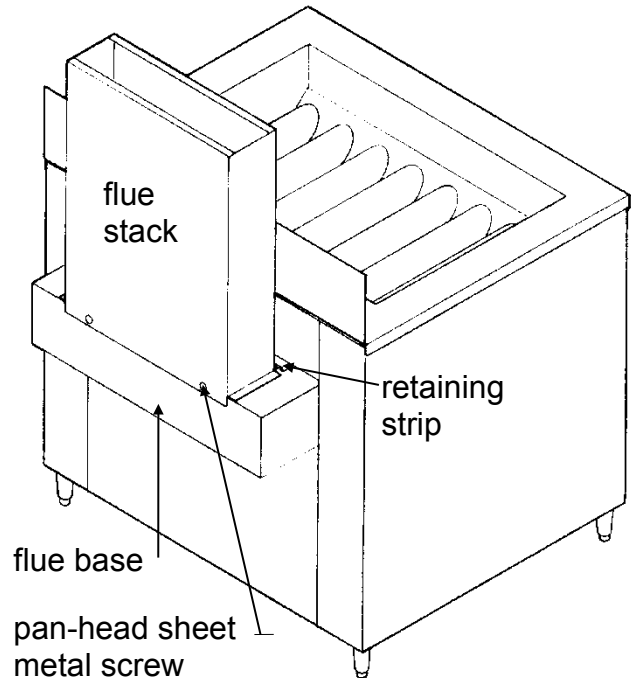
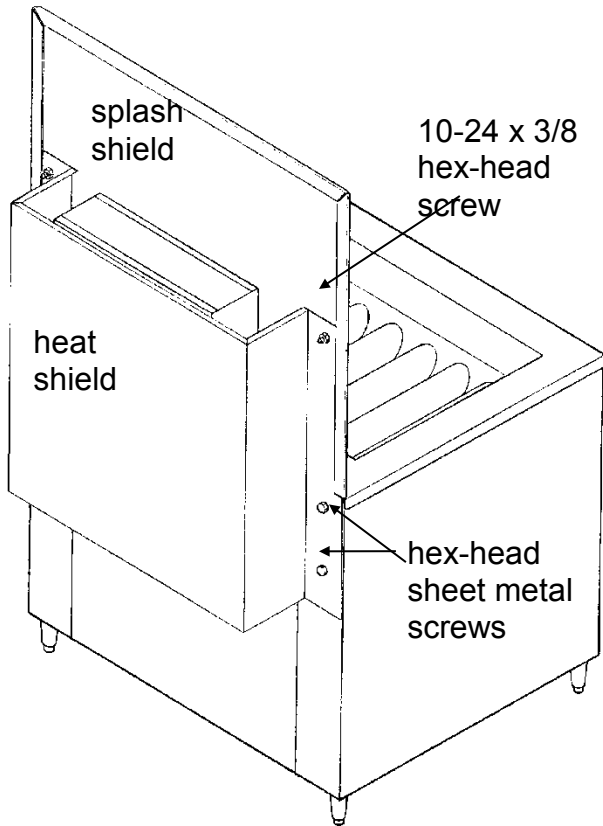

Figure 1-1. Installing the Flue Stack.



using the four hex-head tek screws provided.

Installing the Fryer

1. Make sure the power requirements of the machine, found on the data plate, match your power source.
2. Using a fork lift or pallet jack, lift the fryer cabinet and screw each leg in as far as it will go.
3. Set the fryer cabinet on a flat, dry floor.
4. Level the fryer. Follow these steps:
 - a. Check to see if the fryer is level. To do so, place a level across the top of the fryer cabinet.
 - b. If the fryer is not level, lift the fryer using a fork lift or pallet jack, and turn the legs to adjust them.
 - c. Using the fork lift or pallet jack, lower the fryer to the floor. Be sure that all the

legs rest on the floor when the fryer is level.

5. Bolt the fryer to the floor. The foot of each leg has two holes in it for this purpose.

WARNING

To avoid serious burns, other injury, or death, make sure the fryer is securely fastened to the floor so it will not tip or fall over.

6. If you want to perform pressure testing on the building's gas supply system at pressures greater than 0.5 psig/3.45 kPa, do so now, before you connect the fryer to the gas supply.

CAUTION

To avoid damaging the fryer, do not perform pressure testing on the building's gas supply system at pressures greater than 0.5 psig/3.45 kPa when the fryer is connected to the that system.

7. Connect the fryer to the gas supply, as follows:
 - a. Make sure the gas line to the fryer is the right size. If it is too small, the gas pressure at the burner manifold will be too low, resulting in slow heat recovery, delayed ignition, and pilot outage. (The gas supply line on the fryer itself is 1/2"/1.3 cm I.P.S.)
 - b. Connect the fryer to the building's gas supply.
 - c. Seal all threaded joints between gas pipes with pipe joint compound. You must use a compound that resists the action of liquefied petroleum (LP) gases.
 - d. Bleed the gas lines of all air.
 - e. Check all gas connections and fittings for leaks using a gas leak detector, a soap solution, or a similar substance.

When such a substance is applied to connections and fittings, bubbles indicate gas leaks.

WARNING

To avoid a fire or an explosion which would cause serious burns or death, never use an open flame to check connections for gas leaks.

8. If you want to perform pressure testing on the building's gas supply system at pressures at or below 0.5 psig/3.45 kPa, you may do so now. Before testing, make sure the fryer's individual manual shutoff valve is closed.
9. Connect the fryer to a properly grounded power source.

Ventilation

Adequate ventilation should be provided in the room where the fryer is used. The products of combustion and grease fumes must be removed efficiently and safely without producing drafts that interfere with the burner and pilot operation.

The fryer flue opening must not be located close to the intake of an exhaust blower. Do not connect a flue pipe directly to the fryer flue opening. The minimum vertical distance from the top of the fryer flue opening to the vent system filters must be at least 18 inches.

WARNING

Do not obstruct the flow of combustion and ventilation air to the fryer. When a flame is "starved" for air, it gives off carbon monoxide as a by-product.

Moving the Fryer

If you ever want to move the fryer to a different workstation, follow this procedure:

Assembling the Frying Screen Handles

1. Turn off the fryer and gas valve.
2. Disconnect the machine from the gas supply.
3. Allow the machine and the shortening to cool.

WARNING

Do not touch hot shortening. It can cause serious burns.

4. Remove the shortening from the fryer as explained in "Removing the Shortening" in Section 3.

WARNING

To avoid burns, falls, other injury, or death, never attempt to move the fryer when it has shortening or other liquid in it.

WARNING

Thoroughly clean and dry the floor if shortening is spilled. Materials on the floor can cause people to slip or fall, resulting in serious injury or loss of life.

5. Remove the bolts that secure the fryer to the floor.
6. Using a fork lift, transport the machine to the new workstation.
7. Level the fryer, bolt it to the floor, connect it to the gas line, and connect it to the power source, as explained in "Installing the Fryer" above.

(Be aware that you may be using detachable handles rather than fixed handles, particularly when making raised donuts using screens which

are placed inside a proofer. In this case, your handles should NOT be attached to screens.)

Frying Screens come with handles and hardware unassembled. When assembled the location of the handles should be as follows:

- For Model 618L and 718L Fryers, center the handles along the long sides of the screen.
- For Models 624 and 724, center the handles along any opposing sides of the screen.
- For Models 634 and 734, center the handles along the short sides of the screen.

To assemble Frying Screens, refer to Figure 1-3 opposite.

1. Install #10-32 Nuts (B) on threaded handle rods (A).
2. Locate clips (D) on the screen (C). Center the handles as listed above for each type of fryer.
3. Insert threaded end of handle (A) with handle to outside as shown, making sure that the spacer (E) is in place.
4. Install #10-32 nuts (F) flush onto threaded end of handle (A)
5. Tighten #10-32 Nuts (B) locking handle assembly to screen.

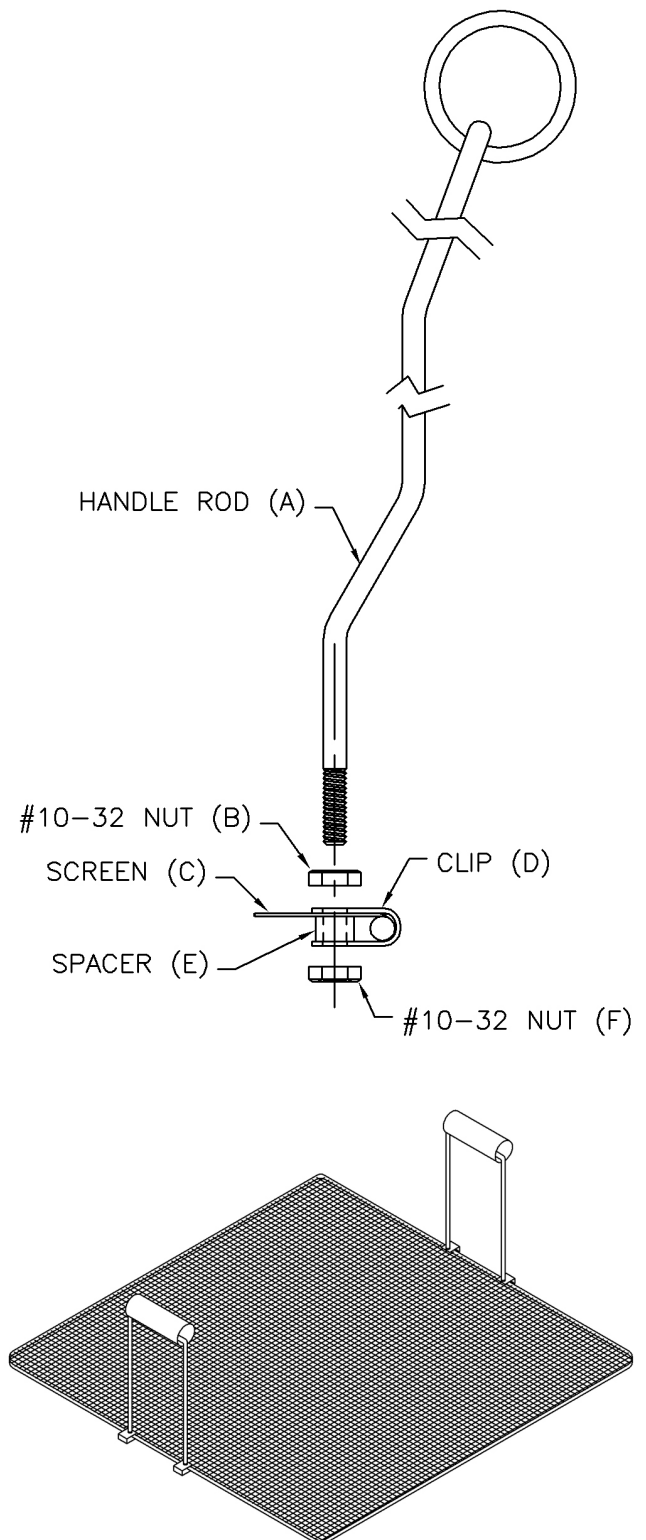

(Above: Figure 1-3)

3

Troubleshooting

If you have a problem with your fryer that you cannot solve, call your dealer or another qualified technician. For electrical troubleshooting refer to the diagrams included with this manual, or to the wiring schematic on the inside of the fryer door.

If your dealer cannot help you, please call Belshaw Bros. at (206) 322-5474. When you call, please specify the following:

- The model name of the machine.
- The serial number of the machine.
- The voltage, phase, and cycle of the machine.

CAUTION

If you perform repairs yourself or have them performed by anyone other than a service technician authorized by Belshaw Bros., you do so at your own risk.

4

Additional Information

Listing and Installation Standards

The following is a selection of listing and installation standards applicable to non-cooking components often supplied as part of food service equipment. The selection is not intended to be complete and other nationally recognized standards may be appropriate.

Component	Listing Standard	Installation Standard
Grease Extractor	ANSI/UL 710-1990	ANSI/NFPA 96-1991
Ventilating Hood	ANSI/UL 705-1984	ANSI/NFPA 96-1991
Filter Unit	ANSI/UL 900-1987	ANSI/NFPA 96-1991
	ANSI/UL 586-1990	ANSI/NFPA 96-1991
Fire Extinguisher (CO2)	ANSI/UL 154-1990	ANSI/NFPA 12-1993
Fire Extinguisher (Dry Chemical)	ANSI/UL 299-1990	ANSI/NFPA 17-1990
Fire Extinguisher (Water)	ANSI/UL 626-1990	ANSI/NFPA 13-1991
Fire Extinguisher (Foam)		ANSI/NFPA 11-1988
Automatic Sprinklers	ANSI/UL 199-1990	ANSI/NFPA 13-1991
Smoke Detectors	ANSI/UL 268-1989	ANSI/NFPA 72-1990
Fire Detection Thermostats	ANSI/UL 521-1988	ANSI/NFPA 92-1990

Robertshaw Type K and S Electric Thermostats

FIELD INFORMATION BULLETIN

Models

K and S

Robertshaw

Model K and S Electric Thermostats

single pole-snap action

▼▼ direct-acting

(Opens or "breaks" circuit on temperature rise)

▼▼ reverse-acting

(Closes or "makes" circuit on temperature rise)

CENTER STEM ADJUSTMENT

This bulletin is intended to give field service men the information needed in installing, checking, adjusting or recalibrating Robertshaw Model K and S Electric Thermostats. As the manufacturer we recommend that field work on these thermostats be limited to the checking and adjusting procedures described herein.

K and S Series thermostats are of snap-action, single-pole, double-break design. Silver contacts and heavy-duty terminals are features that make them excellent for any service requiring durability and sustained accuracy. The power element, which consists of a stainless steel diaphragm with a capillary tube and bulb filled with a liquid having a high coefficient of expansion, provides extreme sensitivity to temperature fluctuations. Thus it will operate within very close temperature differential.

Typical uses of K and S Electric Thermostats are as controls in clothes dryers, window air conditioners, electric space heaters, electric roasters, small electric ovens, and other household appliances.

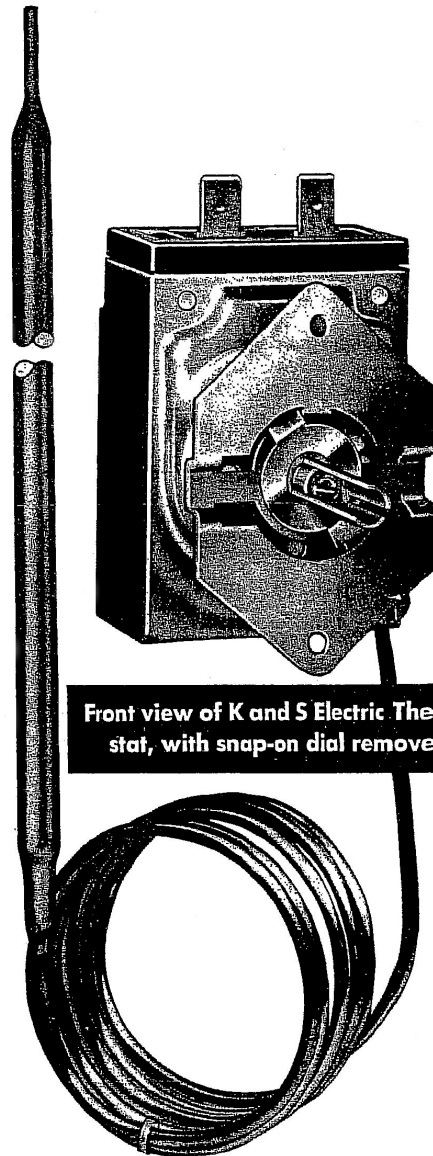

Front view of K and S Electric Thermostat, with snap-on dial removed.

Model K and S Electric Thermostats

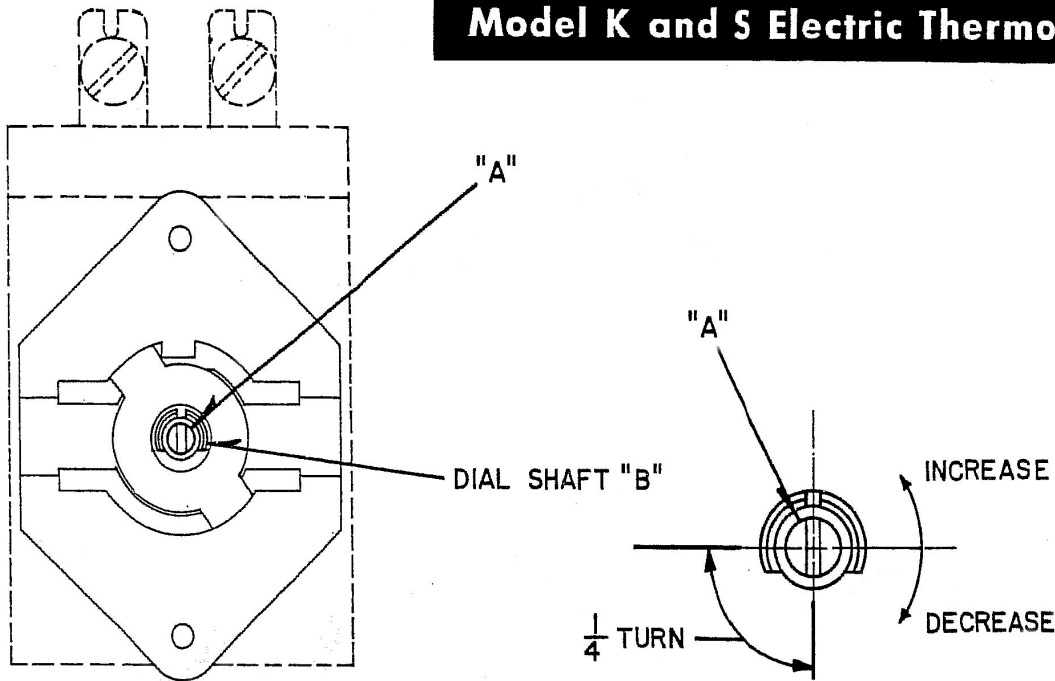

CHECKING CALIBRATION

Each Model K and S Electric Thermostat is adjusted at the factory and calibrated on precision instruments to control temperatures accurately. Adjustment or recalibration is not needed unless the thermostat has been mishandled in transit, or changed or abused while in service.

To Check Calibration

- ① Use a potentiometer or a good grade thermometer to determine temperature at the location where temperature regulation is required.
- ② Turn the dial of the thermostat to a medium temperature setting.
- ③ Allow enough time for temperature to stabilize, or until several temperature readings are identical.

To Recalibrate

Remove knob from dial shaft "B".

Turn screw "A", clockwise to decrease and counter clockwise to increase temperature.

Because of the many temperature ranges available in this thermostat 1/4 turn of screw "A" has different values. The chart below shows the approximate value of 1/4 turn of screw "A" when used on the respective temperature ranges.

<u>TYPE</u> <u>THERMOSTAT</u>	<u>TEMP. RANGE</u> <u>IN DEGREES F.</u>	<u>1/4 TURN IN</u> <u>DEGREES F.</u>
OVEN	150° TO 550°	35°
DRYER	130°-180°	14°
FRYER	200°-400°	18°
STERILIZER	100°-200°	12°
SPECIAL	60°-250°	17°
SPECIAL	250°-850°	35°

Replace knob or control dial.

After a calibration is made let the appliance operate until the temperature has stabilized, then recheck to determine whether or not the calibration has been corrected.



Robertshaw
CONTROLS COMPANY
New Stanton Division
Youngwood, PA 15697

Printed in U.S.A.

SB-168 Submerger Kit Installation

SUBMERGER KIT INSTALLATION 718LCG, 718LFG, 724CG, 724FG, 734CG, and 734FG FRYERS

The submerger kit contains the following:

- Submerger Assembly (see table below for part number).
- 724G-111L Pivot Bracket.
- 724G-111R Pivot Bracket.
- 724G-268 Submerger Latch , lower.
- 724G-270 Submerger Latch , upper.
- 1/4-20 x 5/8 Hex Head Machine Screw (2 required).
- 10-16 x 5/8 Hex Head Sheet Metal Screw (4 required).
- SB-168 Submerger Kit Installation Instructions.

Fryer Model	Submerger Kit Number	Submerger Assembly Number
718LG	718LG-1528	718LG-1009
724G	724G-1528	724G-1009
734G	734G-1528	734G-1009

PIVOT BRACKET INSTALLATION

1. Locate the pivot brackets (A) over threaded holes near the back corners of fryer kettle (right hand bracket is shown in figure 1).
2. Secure brackets to kettle with 1/4-20 x 5/8 hex head screws (B).
3. Fit submerger into brackets.

Figure 1

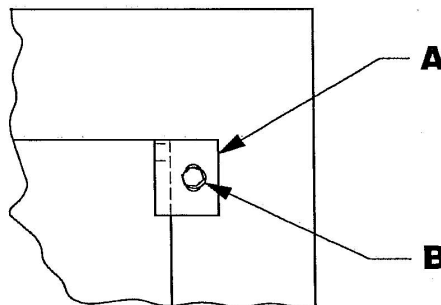

CONTINUED NEXT PAGE

4. If your fryer came with pre-punched mounting slot for lower submerger latch, go to step #5. If your fryer does not have lower submerger latch slot: slip latch under kettle lip in center of kettle. See dimension "A" in chart below. Latch should be approximately 3-1/4" from top of kettle to bottom of latch. Drill two 1/8" diameter holes at center of slots.
5. Secure latch with two 10-16 x 5/8 sheet metal screws.
6. Locate the 724G-270 upper submerger latch, on the fryer back splash panel. Clamp at dimension "B" and "C" (see chart). Install submerger assembly in pivot brackets and check that submerger latches into upper latch. Drill two 1/8" diameter holes into center of slot on latch.
7. Secure upper submerger latch with two 10-16 x 5/8 sheet metal screws.
8. Check that submerger locks into lower latching plate. Adjust up or down as required. To check operation, lift submerger without using the handle. The submerger handle should lock and prevent the submerger screen assembly from rising.

WARNING

Failure to locate the upper submerger latch correctly can cause severe injury from HOT shortening splash.

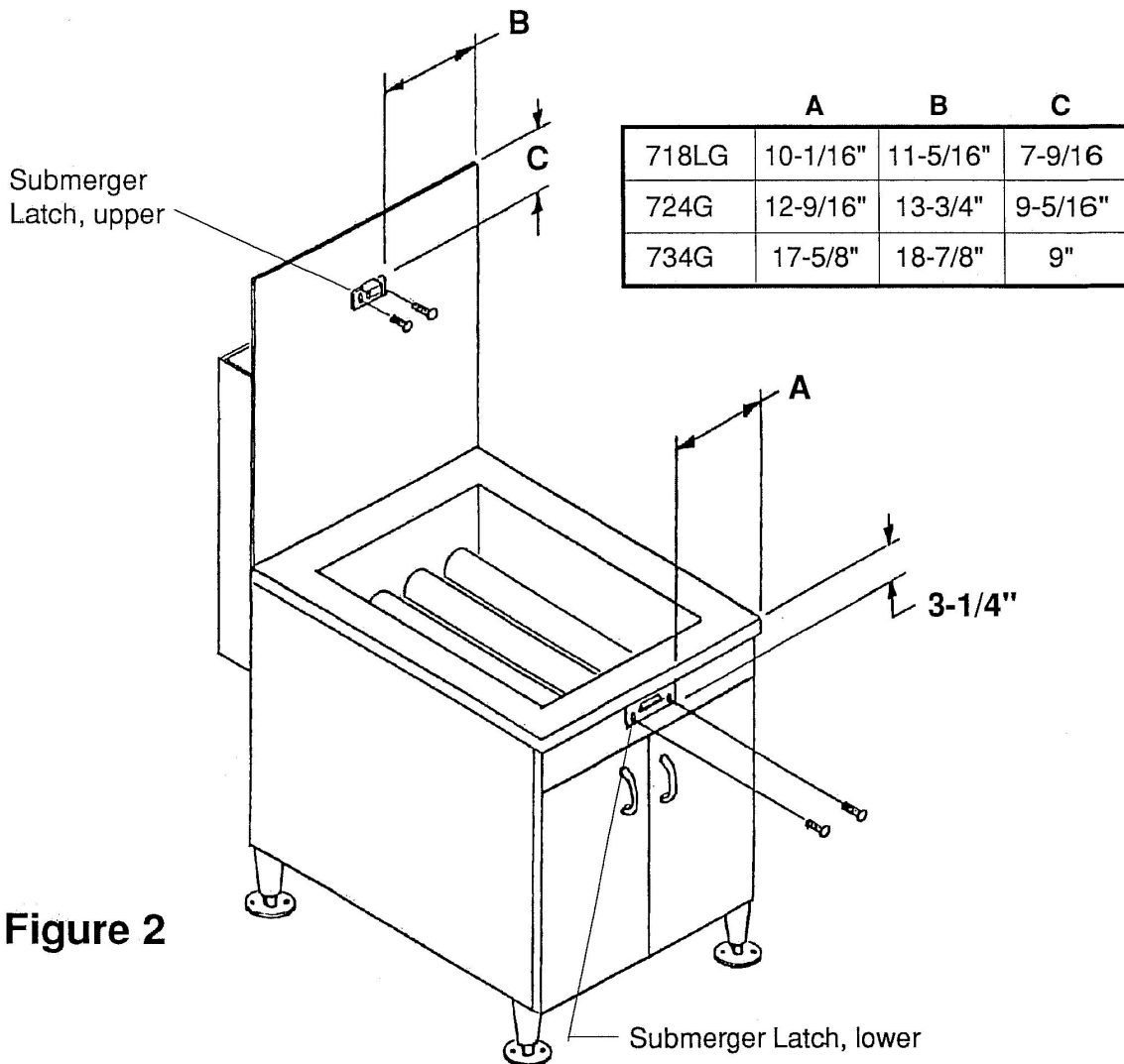

Figure 2

See Parts List Drawing Insert Page.