

OVEN SERIAL NO. _____

MANUAL No. Y-BX-34E

OVEN CODE 149 150 153 156 158 159

CONDENSER SERIAL No. _____ (IF FITTED)

In the event of an enquiry please quote these numbers.

Store this document safely and ensure it is available at all times.
Non-availability may affect the service or repair of your machine.



Bx OVEN

ECOTOUCH CONTROL

OPERATION AND MAINTENANCE OF OVEN AND CONDENSER UNIT (IF FITTED)



Failure to adhere to the operation, cleaning and maintenance instructions detailed in this manual could affect the warranty of this oven.

-DECLARATION OF CONFORMITY-

We hereby declare that this machine complies with the essential health and safety requirements of:-

The Machinery Directive 2006/42/EC

The Low voltage Directive 2006/95/EC

**The requirements of the
Electromagnetic Compatibility Directive
2004/108EC,91/263/EEC,92/31/EEC**

and

**General Safety of Machinery and
food processing Standards applicable**

Signed: 
(G.A.Williams: Quality Manager)

Date:

Machine Code FG..... Machine Serial No.

A technical construction file for this machine is retained at the following address:

MONO EQUIPMENT
Queensway,
Swansea West Industrial Park,
Swansea
SA5 4EB
UK

MONO EQUIPMENT IS A BUSINESS NAME OF AFE GROUP LTD

REGISTERED IN ENGLAND NO. 3872673 VAT REGISTRATION NO.923428136

REGISTERED OFFICE: Unit 35, Bryggen Road, North Lynn Industrial Estate, Kings Lynn, Norfolk, PE30 2HZ

ATTENTION

IF OVEN FAILS TO HEAT UP, WHEN FIRST CONNECTED TO A POWER SUPPLY OR DURING USE AT ANYTIME, PRESS RESET BUTTON(S) LOCATED THROUGH THE REAR BACK PANEL. (DO NOT REMOVE BACK PANEL)

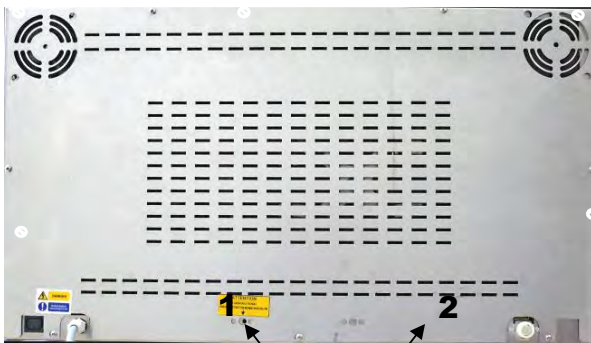

4 TRAY OVEN RESET HOLE LOCATION

*HOLE CAN BE AT POSITION 1 OR
POSITION 2 DEPENDING ON OVEN*

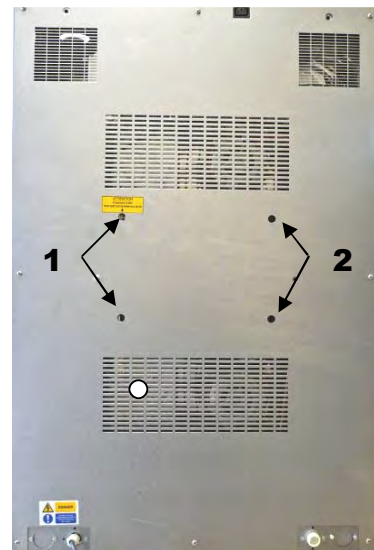

10 TRAY OVEN RESET HOLE LOCATION

*HOLES CAN BE AT
POSITION 1 OR POSITION 2
DEPENDING ON OVEN*

REAR VIEW OF OVENS

IF THIS FAILS TO CORRECT THE SITUATION, PLEASE CONTACT YOUR SUPPLIER



PART 1.0	Introduction	5
PART 2.0	Specifications	6
PART 3.0	Safety	7
PART 4.0	Installation	8
PART 5.0	Isolation	9
PART 6.0	Daily / Weekly Cleaning	10
PART 7.0	Ideal Operating Conditions	12

PART 8.0	TOUCH SCREEN OPERATION	13
	Basic operation	14
8-1.0	Bake using “FAVOURITES” menu	15
8-2.0	“MANUAL” menu	18
8-3.0	“PROGRAMMES” menu	21
8-4.0	“MULTI-BAKE” menu	24
8-5.0	Creating a program	26
8-6.0	7-Day timer	32
8-7.0	Settings	33
	Time and date	34
	Settings – General level	35
	Settings explained – General level	36
	Settings – High level	37
	Settings explained – High level	38
	Default Passcodes	39
8-8.0	Using the USB port	40
8-9.0	Diagnostics	43

PART 9.0	Maintenance	44
PART 10.0	Steam System Maintenance	44
PART 11.0	Light Bulb Replacement	44
PART 12.0	SPARES INFORMATION	45

PART 13.0	CONDENSER INFORMATION (IF FITTED)	79
------------------	--	-----------

MONO Contact Information	91
---------------------------------	-----------

1.0 INTRODUCTION

- A combination of clean industrial design and the latest technology, the **MONO BX oven range** is designed specifically to take the baking Industry's standard trays.
- The ovens in the range are of **stainless steel construction** and some have removable tray racks to aid cleaning.
- The smaller ovens are designed to be **stackable** without separate support, so your business can grow without taking up more ground space.
- The high-speed fans, elements and steam systems give **efficient air circulation** to produce a professional bake across a range of products.
- The doors are **double glazed** to increase the efficiency of the ovens well-insulated baking chamber
- Ovens are supplied with **LCD TOUCH** displays for the user-friendly control panels. A voice prompt facility is also available for the basic instructions like "Bake over".



- The 10-tray Bx is supplied with a 10-tray capacity stainless steel base with locking castors.



- The optional condenser unit can be fitted to any Bx oven or stacked Bx ovens as required. With thermostatic control it can be adjusted to operate in most ambient temperatures.

2.0 SPECIFICATIONS

	4/5 TRAY OVENS			10 TRAY OVENS	
	FG159	FG153	FG158	FG150	FG149
TRAY SIZE	18"x30"	40x60	60x40	18"x30"	40x60
HEIGHT	525mm	525mm	570mm	1170mm	1170mm
HEIGHT OF OVEN ON BASE				1870mm	1870mm
WIDTH	840mm	780mm	1000mm	840mm	780mm
DEPTH – DOOR CLOSED	1269mm	1103mm	890mm	1309mm	1109mm
DEPTH – DOOR OPEN	1828mm	1610mm	1610mm	1870mm	1609mm
WEIGHT (kg)	165	115	110	290	250

POWER (uk versions)

4/5 TRAY OVENS - 240v. 1 PHASE, 50HZ
415v. 3 PHASE, + NEUTRAL + EARTH, 50HZ

10 TRAY OVENS - 415v. 3 PHASE, + NEUTRAL + EARTH, 50HZ

WATER

Supplied with 1 Metre flexible hose – ¾" B.S.P. BOTH ENDS.

WATER PRESSURE 2bar – 4bar
Domestic pressure is usually within this parameter.

Water conditioning unit advised.

No drain required (unless condenser fitted).

In the interest of safety and efficient operation of the oven, it is essential that this manual should be made available to the operator before work is commenced. The following points should be observed and followed at all times.

1. The oven is designed for baking of bread, confectionery and savoury products only. **DO NOT** use it for any other items without consulting with **MONO**.
2. The oven must be allowed to cool before any form of cleaning is started.
3. All repairs and maintenance of electrical units must be carried out by authorised electricians; even then, electrical access panels must not be opened unless the mains supply to the oven is isolated.
4. All connections to the oven must be made in accordance with the statutory requirements of the country of installation.
5. While the oven is in operation (and for some time after use), **it is inadvisable to touch the oven window or the surrounds because of conducted heat.**
6. The oven must be operated as described in this manual.
7. Only **MONO** spare parts should be used on this oven.
8. The construction of the oven must not be changed.
9. The owner of the oven is legally obliged to instruct staff of these safety points and of the safe operation of the oven. **These instructions should not be removed from the working area.**
10. To prevent door glass from shattering - **DO NOT CLEAN OVEN GLASS WHEN HOT.**
11. Customers operating a BX oven in a hard water area must ensure that an efficient water-softening device protects the water supply to the equipment.
12. Oven gloves should be worn when moving products in or out of the oven.

ATTENTION**DO NOT COVER THE DAMPER FLUE**

- The oven should be connected to a wall isolator.

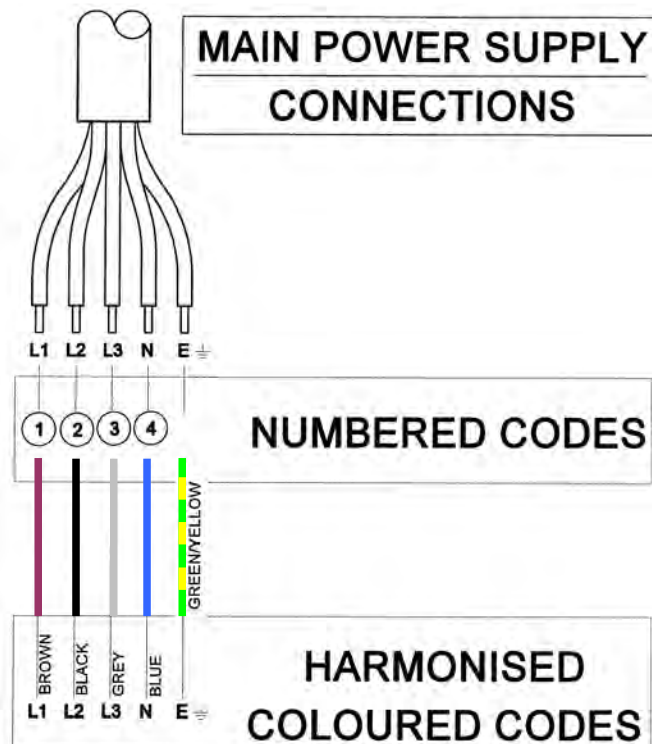

- It is the customers' sole responsibility to arrange adequate ventilation and it should be sufficient to ensure water does not condense on or around the oven. A 50mm gap is required at the sides and rear of this oven. Chimneys and evacuation ducts, fitted above mono ovens should be insulated.
- If an oven with steam has been chosen, connect to a suitable water supply making sure that the pipes are flushed out to remove all foreign bodies i.e. flux or solder. Customers in hard water areas must ensure that an efficient water treatment device protects the supply to the oven. It is the customers' responsibility to install and maintain an adequate water supply to the oven, which should comply with local water regulations.
- In the interests of hygiene, we strongly recommend that before using the oven for the first time you wipe the inside of the oven and all accessories thoroughly with a clean cloth soaked in warm soapy water. Although the utmost care is taken during assembly and pre-delivery inspection, there is always a possibility of residue contaminating the first bake if this is not done.
- Ensure that the locking castors on the base unit (if supplied) are locked into position.

6. **AMBIENT WORKING TEMPERATURES.**

Ambient working temperatures for electric/electronic components such as solenoid switches, circuit breakers, motors etc should be **no more than 40°C (115° f)**

Manufacturers of these and other electrical components advise that any ambient temperature above 40°C affects the functionality of the components and any related guarantees become void. For example, above this temperature motors are not satisfactorily cooled, contactor efficiency is seriously impaired and electronic components shut down. It is the customers' sole responsibility to arrange for adequate ventilation. Any component malfunctioning during the guarantee period that is found to have been subject to excessive humidity or ambient working temperature above 40°C (115°F) will not be covered by the component manufacturers guarantee or MONO's product warranty.

ELECTRICITY SUPPLY

To stop the oven in an emergency, switch off electricity at the wall isolator.

WATER SUPPLY

For stacked ovens, the water supply can be shut off by closing the shut-off valves
(See diagram)

For non-stacked ovens the water supply should be shut off at the nearest shut-off point

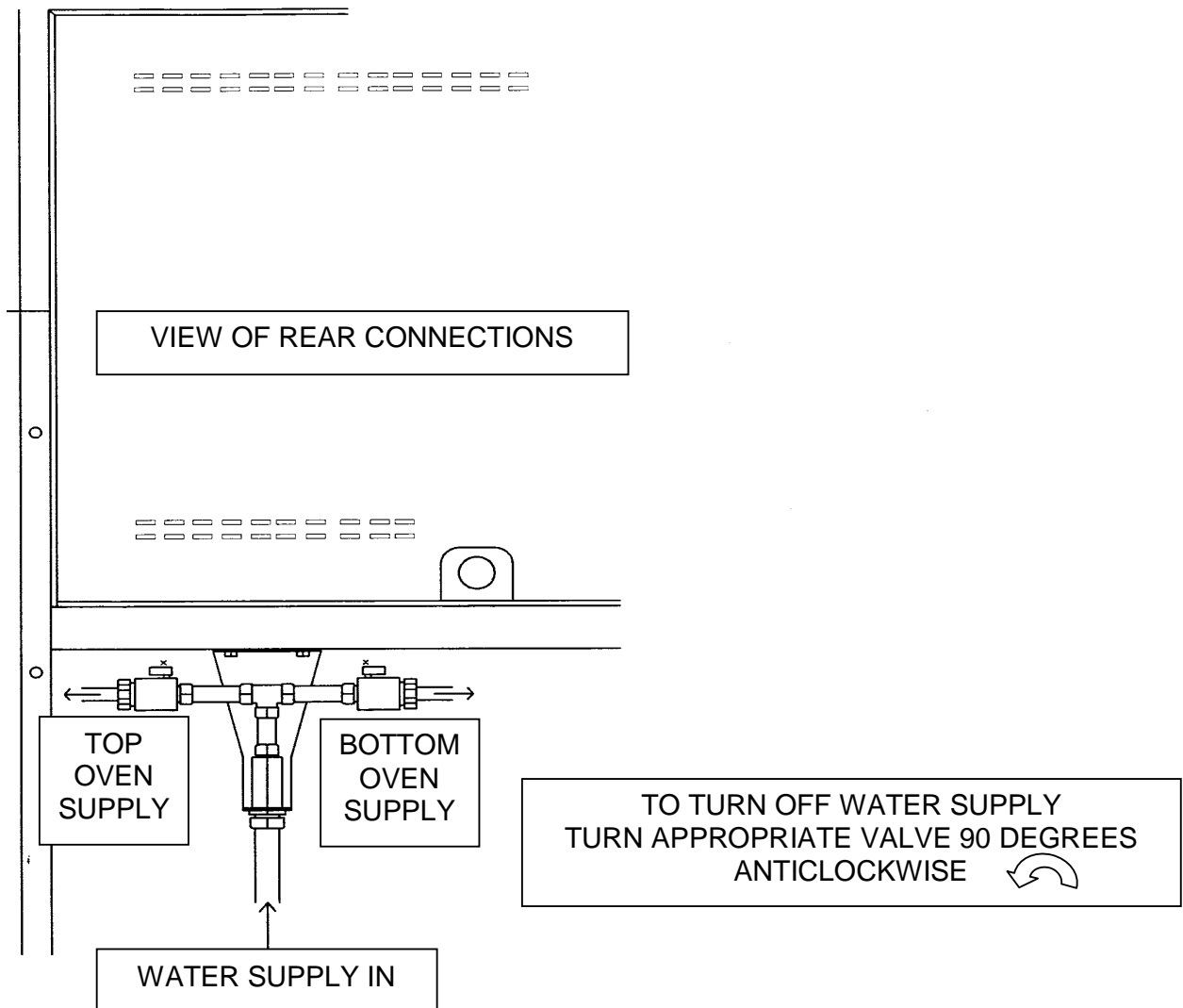

DAILY

**NOTE: BEFORE CLEANING,
ISOLATE OVEN FROM MAINS SUPPLY AND ALLOW TO COOL.**

- The equipment is to be cleaned daily using approved chloride-free cleaning fluid
- Sweep any debris (after it has been allowed to cool) onto oven removable trays and remove for cleaning.
- Brush down and wipe oven front, back and sides.
- Wipe clean with a damp cloth that has been soaked in a solution of mild detergent and hot water.

IMPORTANT:

**TAKE CARE WATER DOES NOT ENTER CONTROL PANEL OR
REAR ACCESS PANEL.**

**DO NOT REMOVE THE REAR PANELLING INSIDE THE OVEN.
THIS ALLOWS ACCESS TO THE FAN ASSEMBLY WHICH IS NOT SAFETY
INTERLOCKED AND COULD CAUSE INJURY**

WEEKLY

**NOTE: BEFORE CLEANING, ISOLATE OVEN FROM MAINS SUPPLY
AND ALLOW TO COOL.**

Complete daily check then

- Clean any burnt-on debris by careful use of a proprietary oven cleaner, carefully following the manufacturer's instructions. Do not allow the oven cleaner to get onto the control panel.
- Scrub cabinet wheels (if fitted), with a mild detergent and hot water using nylon cleaning brush.

Ovens using 60cm x 40cm trays (FG156 2 tray / FG158 4 tray)

Open the oven door and remove internal racking from sides of oven.

(lift and unlatch racking).

This allows access to hidden areas in the oven, which can be wiped with a damp cloth.

Wipe down, and clean racking with a damp cloth and replace.

4 tray ovens

The inner door glass is hinged to enable cleaning of internal surfaces.

To open, remove the two screws shown in the picture below.

The internal surfaces of the door glass can then be cleaned using a suitable glass cleaner.

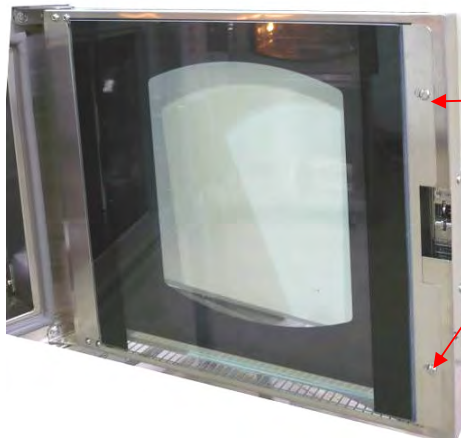

Remove these screws
to release inner glass
for cleaning

- Room should be allowed for the door to open fully to allow easy loading and unloading of product without people coming in contact with hot surfaces.
- Racks should be available to allow cooked products to cool safely.
- Oven gloves should be available at all times.
- It is the customers' sole responsibility to arrange adequate ventilation and it should be sufficient to ensure water does not condense on or around the oven. A 50mm gap is required at the sides and rear of this oven.
- Chimneys and evacuation ducts, fitted above mono ovens should be insulated

AMBIENT WORKING TEMPERATURES.

Ambient working temperatures for electric/electronic components such as solenoid switches, circuit breakers, motors etc should be **no more than 40°C (115° f)**

Manufacturers of these and other electrical components advise that any ambient temperature above 40°C affects the functionality of the components and any related guarantees become void. For example, above this temperature motors are not satisfactorily cooled, contactor efficiency is seriously impaired and electronic components shut down. It is the customers' sole responsibility to arrange for adequate ventilation. Any component malfunctioning during the guarantee period that is found to have been subject to excessive humidity or ambient working temperature above 40°C (115°F) will not be covered by the component manufacturers guarantee or MONO's product warranty.



Section 8

TOUCH SCREEN OPERATING INSTRUCTIONS

BASIC OPERATION

ALL OPERATIONS ARE ACTIVATED BY TOUCHING AREAS ON THE SCREEN, WHICH WILL PASS YOU ON TO THE NEXT INFORMATION PANEL.

DO NOT USE EXCESSIVE FORCE.
(THE PRESSURE REQUIRED TO OPERATE THE PANEL CAN BE ALTERED IN THE SETTINGS SECTION)

TOUCH THE SCREEN
ON THE AREA YOU
REQUIRE TO
ACTIVATE



STANDBY
THE OVEN TURNS OFF.
TOUCH THE SCREEN TO GO TO
THE OPTION SCREEN.

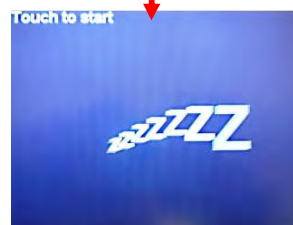

SLEEP
THE OVEN STAYS AT 100c AND
HEATS TO LAST PROGRAM
TEMPERATURE WHEN THE
SCREEN IS TOUCHED.
OPTION SCREEN THEN SHOWS.

8 -1.0 BAKING USING FAVOURITES MENU

TOUCH TO OPEN THE FAVOURITES SELECT SCREEN

1



OPTION SCREEN

TOUCH THE NAME OF THE PRODUCT REQUIRED

2



SELECT SCREEN

TOUCH THE "FULL LOAD" OR "HALF LOAD" AS REQUIRED

3

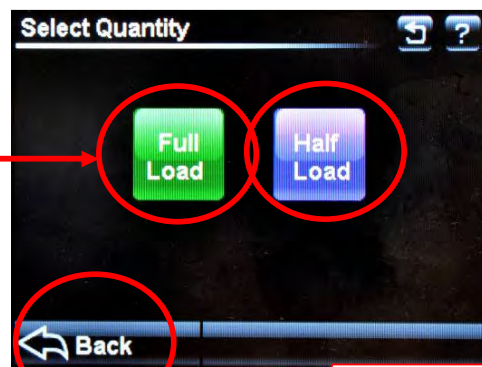

LOAD SCREEN

TO RETURN TO THE PREVIOUS SCREEN TOUCH THE "BACK" BUTTON AT ANY TIME

IF THE OVEN IS NOT UP TO TEMPERATURE IT WILL SHOW THE HEATING SCREEN.

WAIT FOR THE OVEN TO REACH TEMPERATURE

IF THE OVEN IS TOO HOT FOR THE TEMPERATURE CHOSEN, THE SCREEN WILL TELL YOU TO OPEN THE DOOR TO AID COOLING.

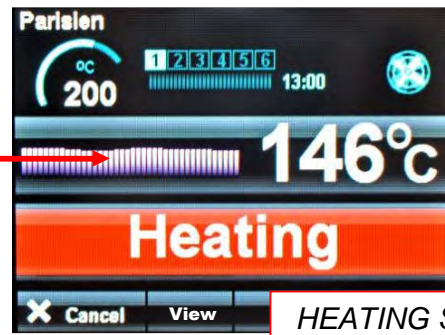

HEATING SCREEN

READY SCREEN

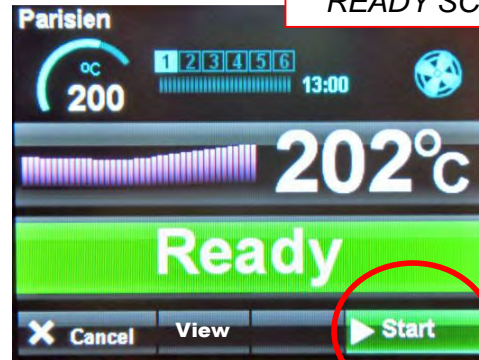

WHEN OVEN IS AT THE CORRECT TEMPERATURE THE "READY" SCREEN WILL SHOW.

1. OPEN DOOR AND LOAD PRODUCT.
2. CLOSE THE DOOR FULLY.
3. TOUCH "START"

TIP
TO HELP TO KEEP THE OVEN HOT, TRY NOT TO KEEP THE DOOR OPEN MORE THAN NEEDED

4

BAKE IN PROGRESS SCREEN

THIS SCREEN WILL SHOW WHILE THE PRODUCT IS BAKING

SET TEMPERATURE

TEMPERATURE PROFILE BAR

BAKE TIME PROGRESS BAR

NOTE

The actual temperature shown will rise and fall above and below the set temperature as the oven cools and reheats. This is not a fault

BAKE PHASE (WHEN USED)

ACTUAL OVEN TEMPERATURE



BAKE TIME LEFT

BAKE OVER SCREEN

5
AT THE END OF THE BAKE TIME A
SOUNDER WILL BE HEARD AND
"BAKE OVER" WILL FLASH.
TOUCH "**STOP**" AND OPEN THE
DOOR TO REMOVE THE PRODUCT.

TO KEEP THE OVEN BAKING FOR
EXTRA MINUTES
THE "+ 10 MIN" BUTTON CAN BE
TOUCHED.
(THIS TIME CAN BE ALTERED IN
SET UP)



TOUCHING "VIEW" BUTTON DURING A BAKE

TOUCHING "**VIEW**" BUTTON
DURING A BAKE WILL SHOW THE
SETTINGS FOR THE BAKE IN PROGRESS.
TOUCH "**CANCEL**" TO GO BACK TO THE
PREVIOUS SCREEN.

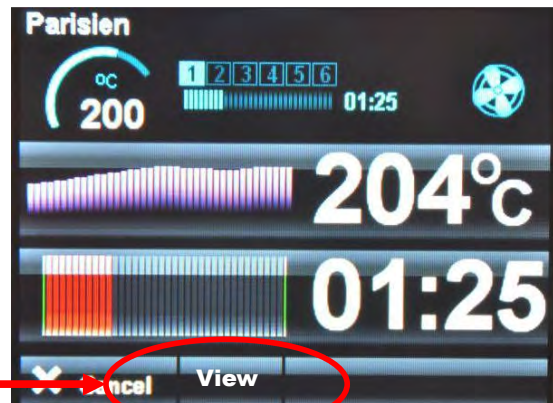

VIEW SCREEN

8 - 2.0 BAKING USING MANUAL MENU

PRESS TO OPEN
MANUAL BAKE
SCREEN

1



OPTION SCREEN

SET BAKE TIME AND TEMPERATURE



MANUAL BAKE SCREEN

SET BAKE TEMPERATURE

TOUCH TEMPERATURE ON THE SCREEN
TO ACTIVATE THE KEYBOARD SCREEN.
KEY IN REQUIRED TEMPERATURE AND
TOUCH "DONE"

2



SET BAKE TIME

TOUCH TIME ON THE SCREEN TO
ACTIVATE THE KEYBOARD SCREEN.
KEY IN REQUIRED TIME AND
TOUCH "DONE"

3



NOTE:

TIME DOES NOT HAVE TO BE SET IN MANUAL MODE. (ONLY TEMPERATURE)
WHEN START IS TOUCHED, THE TIME WILL COUNT UP INSTEAD OF DOWN.
TOUCH STOP TO FINISH BAKE.

USE STEAM TIME AND DAMPER IF REQUIRED

STEAM

4

TOUCH AND HOLD FOR THE TIME (SECONDS) STEAM IS REQUIRED. (THIS CAN BE USED BEFORE OR DURING THE BAKE)

DAMPER

5

TOUCH TO OPEN THE DAMPER. (SYMBOL GOES GREEN)
TOUCH TO CLOSE THE DAMPER. (SYMBOL GOES RED)



CANCEL

TOUCH AT ANYTIME TO GO BACK TO THE SETTING SCREEN.

MANUAL BAKE SCREEN 2

START

TOUCH "START" TO START BAKE

6



TOUCH "STOP" WHEN END OF BAKE BUZZER SOUNDS OR WHEN REQUIRED IF NO TIME WAS ENTERED

7

SAVE MANUAL PROGRAM, IF REQUIRED

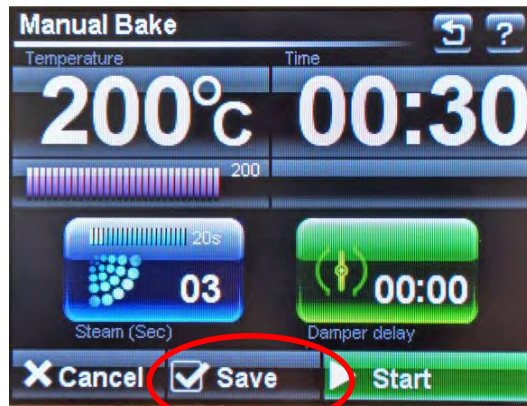

MANUAL BAKE SCREEN 3

SAVE SETTINGS

IF NO TIME WAS ENTERED AT THE START OF THE BAKE, WHEN STOP IS TOUCHED "SAVE" WILL APPEAR AT THE BOTTOM OF THE SCREEN. "SAVE" CAN BE TOUCHED AND AN OPTION SCREEN WILL APPEAR.

7

TOUCH "ADD TO FAVOURITES" OR "SAVE AS"



USE KEYBOARD TO TYPE THE REQUIRED NAME AND PRESS "SAVE"



NOTE: In manual mode, only one operation of the steam or damper is saved.

8 - 3.0 BAKING USING PROGRAMMES

NOTE : THIS COVERS TWO VERSIONS OF FIRMWARE. THE OVEN CAN BE SET TO SHOW EITHER
 1. PICTORIAL CHOICES OF PRODUCT CATERGORIES
 2. A NUMERICAL VERSION THAT SHOWS RANGES OF PROGRAM NUMBERS.

TOUCH TO OPEN
 "CATEGORY" or
 "PROGRAM CHOICE"
 SCREEN

1



OPTION SCREEN

CATEGORY SCREEN

PROGRAM CHOICE SCREEN

TOUCH THE TYPE OF
 PRODUCT OR
 PROGRAM RANGE
 CHOICE WANTED
 AND "SELECT"
 SCREEN
 OPENS

2

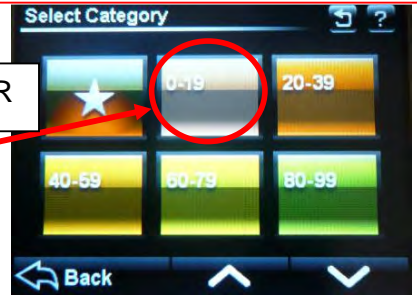

OR

MORE SCREENS

TOUCH THE
 NAME OR NUMBER
 OF THE PRODUCT
 REQUIRED

3

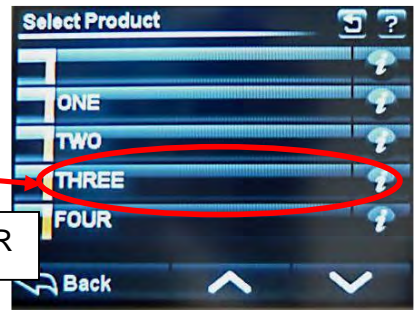

OR

MORE PRODUCTS IF AVAILABLE

SELECT SCREEN

TOUCH THE
 "FULL LOAD" OR
 "HALF LOAD" AS
 REQUIRED

4



LOAD SCREEN

TOUCH THE "BACK"
 BUTTON AT ANY TIME
 TO RETURN TO THE
 PREVIOUS SCREEN

IF THE OVEN IS NOT UP TO TEMPERATURE IT WILL SHOW THE HEATING SCREEN.

WAIT FOR THE OVEN TO REACH TEMPERATURE

IF THE OVEN IS TOO HOT FOR THE TEMPERATURE CHOSEN, THE SCREEN WILL TELL YOU TO OPEN THE DOOR TO AID COOLING.

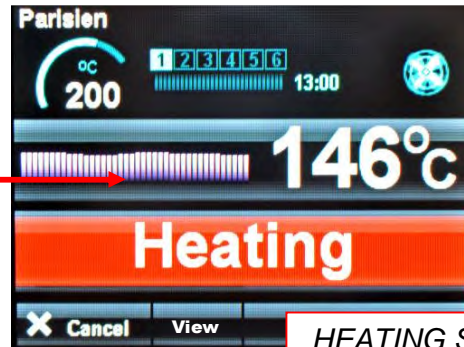

HEATING SCREEN

READY SCREEN

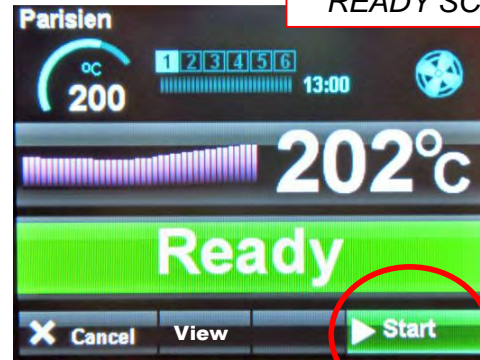

WHEN THE OVEN IS AT THE CORRECT TEMPERATURE, THE "READY" SCREEN WILL SHOW.

1. OPEN DOOR AND LOAD PRODUCT.
2. CLOSE THE DOOR FULLY.
3. TOUCH "START"

TIP
TO HELP TO KEEP THE OVEN HOT, TRY NOT TO KEEP THE DOOR OPEN MORE THAN NEEDED

5

THIS SCREEN WILL SHOW WHILE THE PRODUCT IS BAKING

BAKE PHASE (WHEN USED)

ACTUAL OVEN TEMPERATURE

SET TEMPERATURE

TEMPERATURE PROFILE BAR

BAKE TIME PROGRESS BAR



BAKE TIME LEFT

NOTE
The actual temperature shown will rise and fall above and below the set temperature as the oven cools and reheats. This is not a fault

BAKE OVER SCREEN



6

AT THE END OF THE BAKE TIME A SOUNDER WILL BE HEARD AND "BAKE OVER" WILL FLASH. TOUCH "**STOP**" AND OPEN THE DOOR TO REMOVE THE PRODUCT.

TO KEEP THE OVEN BAKING FOR EXTRA MINUTES THE "+ 10 MIN" BUTTON CAN BE TOUCHED. (THIS TIME CAN BE ALTERED IN SET UP)

TOUCHING "VIEW" BUTTON DURING BAKE

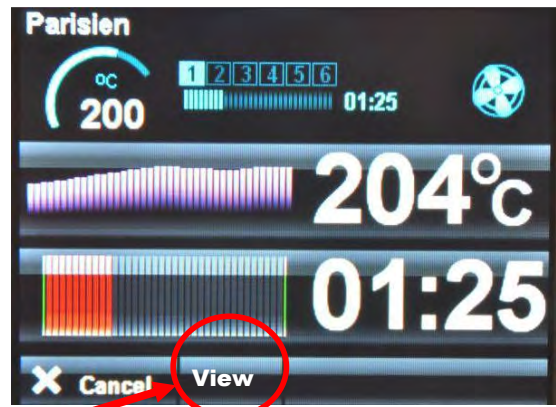

TOUCHING "VIEW" BUTTON DURING BAKE WILL SHOW THE SETTINGS FOR THE BAKE IN PROGRESS. TOUCH "**CANCEL**" TO GO BACK TO THE PREVIOUS SCREEN.



VIEW SCREEN

8 - 4.0 BAKING USING MULTI-BAKE MENU

Multi-bake allows the setting of up to four bake timers so that up to four different products can be baked in the same load. (Products must all use the same temperature).

TOUCH TO OPEN
"MULTI-BAKE"
SCREEN

1



OPTION SCREEN

TEMPERATURE
(FOR ALL TIMERS)

MINUTES

SECONDS

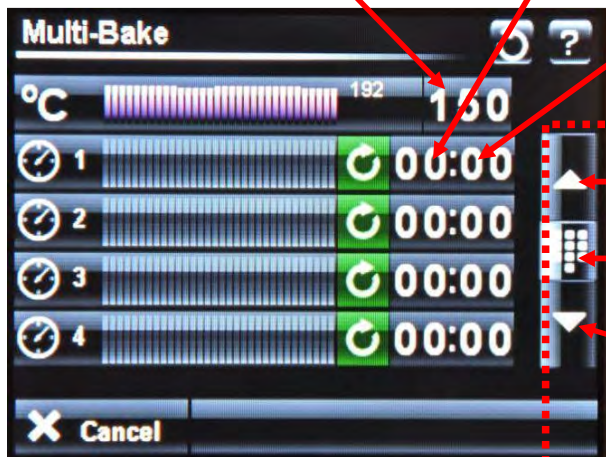

MULTI-BAKE SETUP SCREEN

INCREASE

OR USE KEYS

DECREASE

ENTER AMOUNT REQUIRED AND TOUCH DONE

Touch temperature and set by using up and down keys (or press the number pad symbol and a keypad appears). Enter the value required and touch done.

Set each timer as required. (You do not have to set all four)

Touch minutes and set by using up and down keys (or touch the number pad symbol and a keypad appears). Enter the value required and touch done.

Touch seconds and set by using up and down keys (or press the number pad symbol and a keypad appears). Enter the value required and touch done.

2



MULTI-BAKE SETUP SCREEN SHOWING FOUR TIMERS SET

TOUCH THE START BUTTON WHEN REQUIRED AND THE TIMER WILL COUNT DOWN. **3**



TOUCH TO STOP TIMER

MULTI-BAKE SETUP SCREEN WITH FOUR TIMERS RUNNING



AT THE END OF A SET TIME A BUZZER SOUNDS. TOUCH RED BAR TO STOP **4**

8 - 5.0 CREATING A PROGRAM

TOUCH TO OPEN
"CATEGORY"
SCREEN

1



OPTION SCREEN

TOUCH THE TYPE
OF PRODUCT
WANTED AND THE
"SELECT" SCREEN
OPENS

2



CATEGORY SCREEN



SELECT SCREEN

TOUCH THE DOWN ARROW
UNTIL A BLANK PROGRAM
IS REACHED.

3

TOUCH "I" BUTTON
NEXT TO THE BLANK
PROGRAM TO OPEN
NEXT SCREEN

4

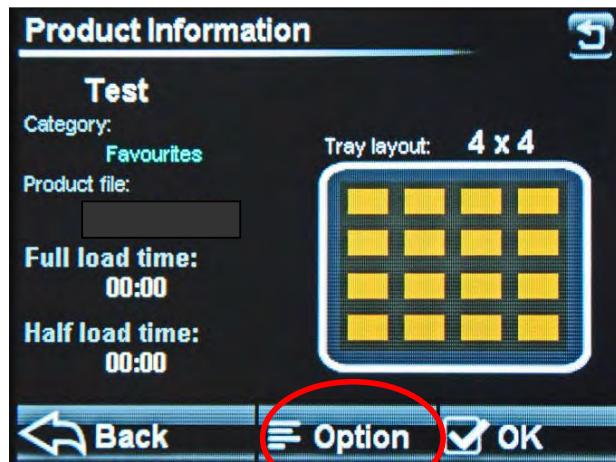

INFORMATION SCREEN

TOUCH OPTION TO GO TO
PASS CODE SCREEN

5

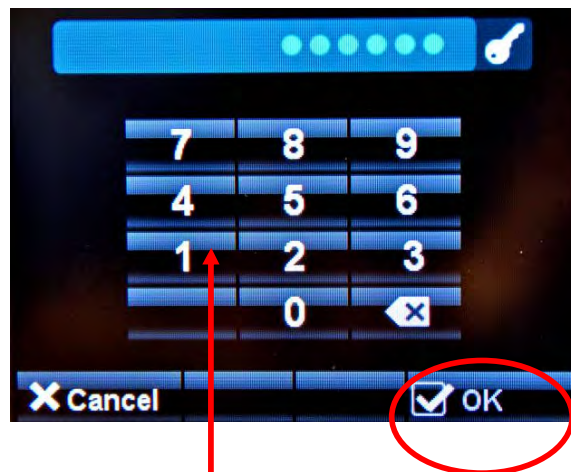

PASS CODE SCREEN

ENTER "SUPERVISOR" PASS CODE AND
THEN TOUCH OK.
(DEFAULT CODE = 123456)

6

CHANGE PRODUCT

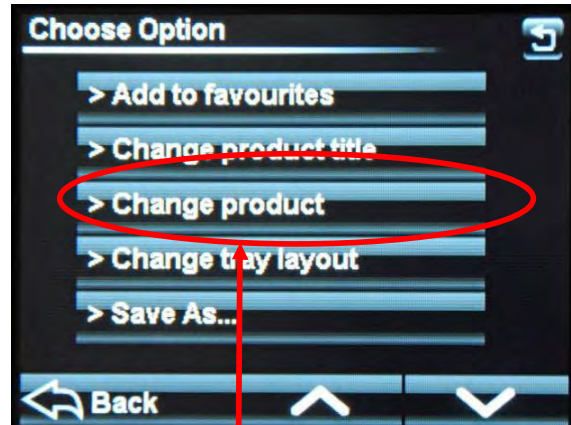

OPTION SCREEN

TOUCH "CHANGE PRODUCT"

7

LOAD TYPE

VALUE CHANGE SCREEN

The screenshot shows the 'Full load' settings screen. At the top, it displays 'Total Bake Time: 02:00' and 'Total Steam Time: 4s'. Below this are six numbered tabs (1-6), with '1' selected. The settings are arranged in a grid:

- Temperature: 200 °C
- Steam Time: 04 secs
- Phase Time: 02:00 mm:ss
- Fan Cycles: 05
- Fan Dwell: 03 secs
- Damper Delay: 03:00 mm:ss

At the bottom are 'Cancel' and 'Save' buttons. A red circle highlights the 'Save' button. To the right, a keypad is shown with '201' entered. Labels with arrows point to various elements:

- 'BAKE PHASE (IF REQUIRED)' points to the numbered tabs.
- 'INCREASE' points to the up arrow on the keypad.
- 'OR USE KEYS' points to the keypad.
- 'DECREASE' points to the down arrow on the keypad.
- 'ENTER AMOUNT REQUIRED AND PRESS DONE' points to the 'Done' button on the keypad.

POWER LEVEL

TOUCH EACH ITEM AND CHANGE THE VALUE BY USING THE UP AND DOWN KEYS OR BY USING THE KEY PAD.

TOUCH "FULL LOAD" TO CHANGE TO "HALF LOAD" SETTINGS IF REQUIRED. PRESS AGAIN TO GO BACK TO "FULL LOAD"

TOUCH "SAVE" WHEN SATISFIED WITH THE SETTINGS OF EACH LOAD TYPE.

8

CHANGE TRAY LAYOUT

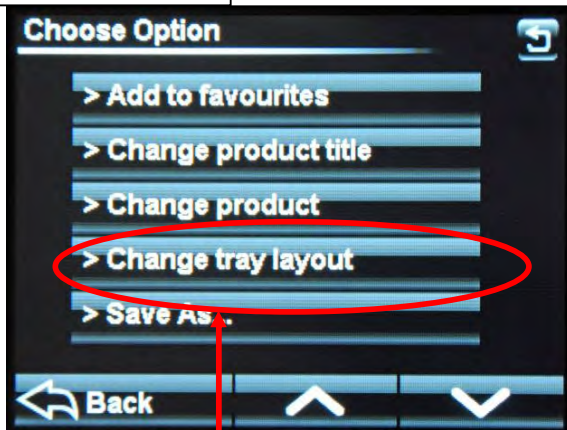

OPTION SCREEN

TOUCH "CHANGE TRAY LAYOUT"

9

TOUCH TO ADJUST
NUMBER OF PRODUCTS
ACROSS THE TRAY

TOUCH TO ADJUST
NUMBER OF PRODUCTS
DOWN THE TRAY

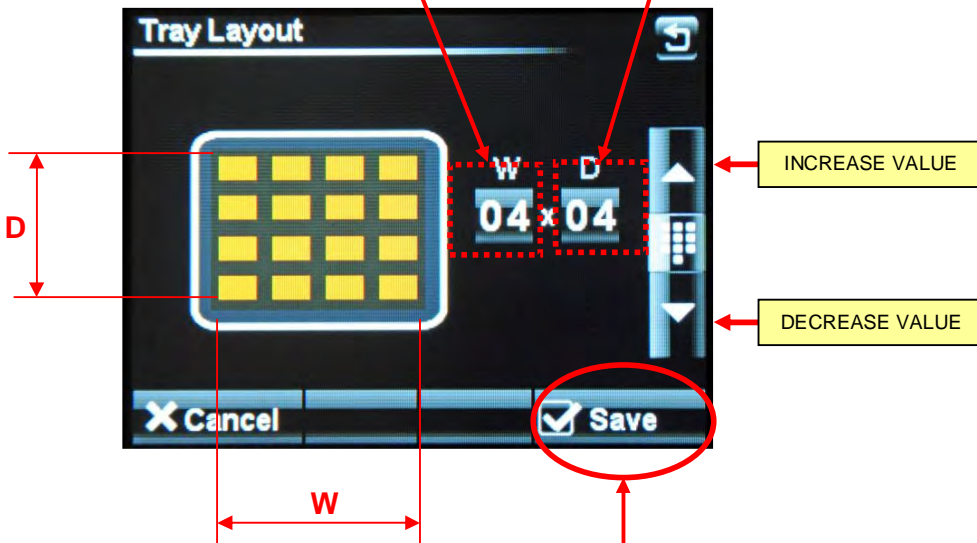

WHEN SATISFIED WITH THE TRAY
LAYOUT TOUCH "SAVE" TO RETURN
TO THE "OPTIONS" SCREEN

10

SAVE

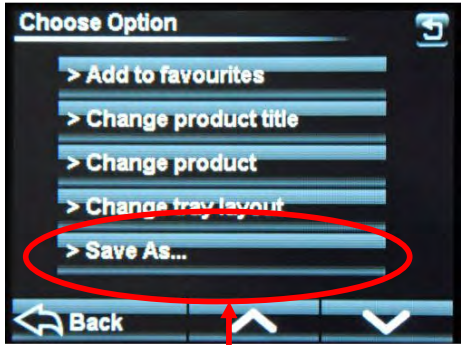

OPTION SCREEN

TOUCH "SAVE AS" 11

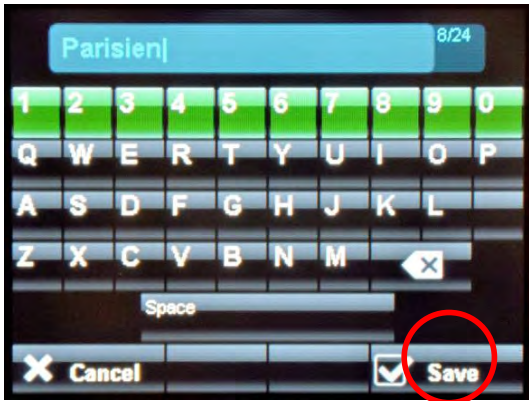

KEYBOARD SCREEN

TYPE IN THE NEW NAME AND TOUCH "SAVE" 12

ADD A PRODUCT TO THE FAVOURITES LIST



CATEGORY SCREEN

TOUCH THE TYPE OF PRODUCT WANTED AND THE "SELECT" SCREEN OPENS

1



SELECT SCREEN

TOUCH THE "i" (INFORMATION) BUTTON NEXT TO THE PRODUCT YOU WANT AS A FAVOURITE. THIS OPENS THE OPTION SCREEN

2

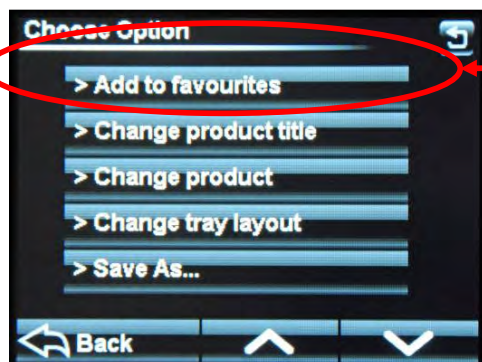

OPTION SCREEN

TOUCH "ADD TO FAVOURITES"

THE PRODUCT WILL NOW SHOW ON THE FAVOURITES LIST

3

8 - 6.0 SETTING 7-DAY TIMER

TOUCH TO OPEN
"7-DAY TIMER"
SCREEN **1**



OPTION SCREEN

CHOOSE DAY

SET "ON" TIME **2**

SET "OFF" TIME **4**



INCREASE VALUE

3

DECREASE VALUE

TIMER SETUP SCREEN

NOTE

Up to four on/off times can be set for each day.
Touch "clear" to clear the settings on the day shown.
Touch "save" to activate the times set.

8 - 7.0 SETTINGS



TOUCH TO OPEN THE "SETTINGS" SCREEN

OPTION SCREEN



PASS CODE SCREEN

ENTER "SUPERVISOR" CODE AND THEN TOUCH "OK". (DEFAULT CODE = 123456) **1**

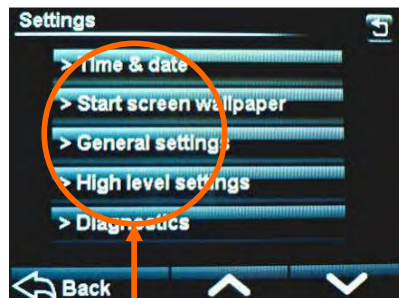

SETTINGS SCREEN

CHOOSE THE SETTING TO ALTER **2**

TIME AND DATE

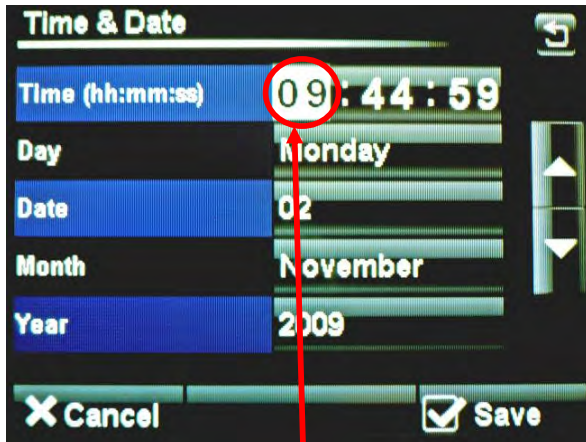

TOUCH THE SCREEN TO HIGHLIGHT THE ITEM TO CHANGE **1**

USE THE INCREASE / DECREASE BUTTONS TO ALTER THE SETTINGS **2**



TIME AND DATE SCREEN

WHEN ALL INFORMATION IS CORRECT, TOUCH "SAVE". THIS WILL RETURN TO THE SETTINGS SCREEN **3**



SETTINGS SCREEN

OVEN SETTINGS (GENERAL)

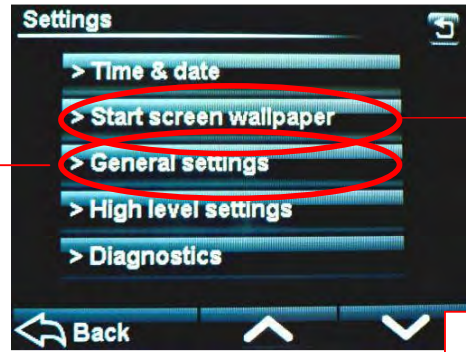

SETTINGS SCREEN

TOUCH "GENERAL SETTINGS" AND THE FOLLOWING SCREEN WILL APPEAR.

SCROLL DOWN TO MOVE THROUGH ALL CHOICES AND ADJUST EACH ONE AS REQUIRED, USING THE ARROW KEYS.

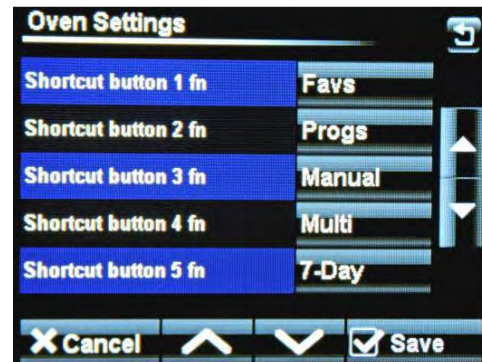
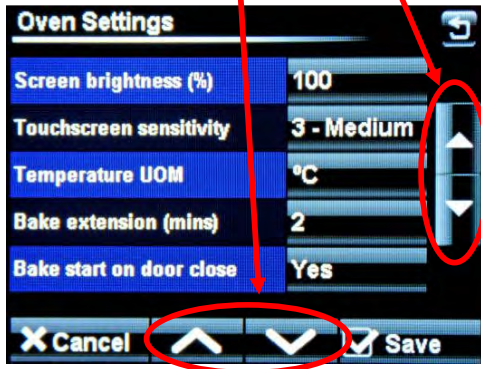

OVEN SETTINGS EXPLAINED - GENERAL LEVEL

SCREEN BRIGHTNESS –

Adjusts the brightness of the viewing screen for user comfort.

TOUCHSCREEN SENSITIVITY –

Adjusts the pressure required to operate the touch screen. (5 settings)

TEMPERATURE UNIT OF MEASURE –

Centigrade (Celsius) or Fahrenheit

BAKE EXTENSION (mins) –

Adjusts the extra time at the end of a bake for each “extra time” button press. (10mins max)

BAKE START ON DOOR CLOSE –

This will start the set bake program as soon as the door closes.

SLEEP MODE DELAY –

Oven will go into sleep mode after the set minutes, providing it is up to temperature and has been through at least one bake cycle.

8 HOUR COUNTDOWN TIMER –

After 8 hours the oven gives a warning and then turns off.
Press any button for an extra hour if required.

POWER LEVEL (1-4) –

Set these as required for each level to be used.

CHART INTERVAL –

Time interval in seconds that the bars show on the heat and bake time progress charts.

SOUNDER SELECT –

Set as external or onboard.

SOUNDER TONE –

Select a tone – Voice or Off

SOUNDER VOLUME –

Adjust to suit the volume required. (onboard sounder only)

SHORTCUT BUTTONS –

1 fn

2fn

3fn

4fn

5fn

Gives the choice of what buttons are active and in which order they appear on the options screen.
Options available = Favourites, Programs, Manual bake, Multi bake, 7-day timer . (Settings at **6fn** can not be changed)

OVEN SETTINGS (HIGH LEVEL)



TOUCH "HIGH LEVEL SETTINGS" AND THE FOLLOWING SCREEN WILL APPEAR.

1

SETTINGS SCREEN



ENTER "HIGH LEVEL" PASS CODE AND THEN TOUCH "OK".

2

THE FOLLOWING SCREEN WILL APPEAR.

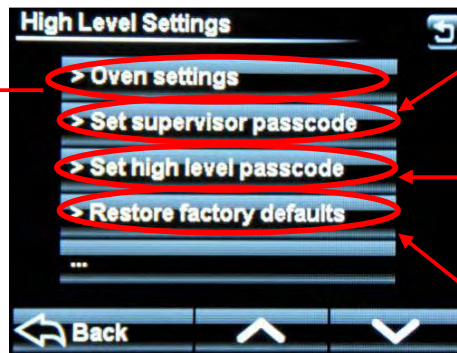

CHANGE SUPERVISOR PASSWORD HERE

CHANGE HIGH LEVEL PASSWORD HERE

RESTORES ALL SCREENS BACK TO ORIGINAL DEFAULT SETTINGS (NOT PASSCODES)

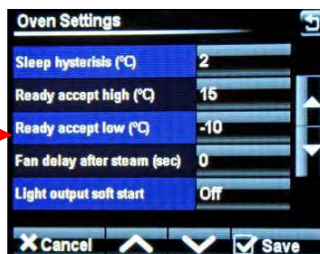

SCROLL DOWN TO MOVE THROUGH ALL CHOICES AND ADJUST EACH ONE AS REQUIRED, USING THE ARROW KEYS.

3

OVEN SETTINGS EXPLAINED - HIGH LEVEL

OVEN TYPE –

Set this to the type of oven that the screen is installed on.

MAX. BAKE TEMPERATURE –

Can be set up to 300C , (depending on the oven type)

TEMPERATURE OFFSET –

Can be used to adjust the display to the actual temperature in the oven.

BAKE HYSTERISIS –

Sets bake temperature cycling around a set point. (Above and below).

SLEEP FALLBACK –

Temperature of the oven in “sleep mode” (100C is suggested).

SLEEP HYSTERISIS –

Sets “sleep mode” temperature cycling around a set point. (Above and below).

READY ACCEPT HIGH –

Highest temperature for the oven to display “READY”

READY ACCEPT LOW –

Lowest temperature for the oven to display “READY”

FAN DELAY AFTER STEAM –

Delay before fan starts after the oven has steamed. (60 seconds max)

LIGHT OUTPUT SOFT START –

On/Off Some lights need this for cold start up to stop them blowing.

AUTO FAN CYCLE TIME (MINS) –

Set time required.Only used in manual and multibake modes.

AUTO FAN DWELL TIME –

Set time required.Only used in manual and multibake modes.

HEATER CONTROL –

Contact or solid state. Defaults to contactor. (solid state not used at the moment)

I/O DIAGNOSTIC –

Displays outputs and inputs at the top of the screen to aid fault finding if needed.

DEFAULT PASSCODES

SUPERVISOR (LOW LEVEL) -- 123456

HIGH LEVEL -- 654321

MASTER -- 314159 (This is fixed)

SUGGESTION

To stop unauthorised changes to the oven setup, it is suggested that this page is removed from this manual and kept in a safe place for future reference.

If tampering could be a problem It is also a good idea to change the passcodes at regular intervals.

8 - 8.0 USING THE USB PORT



START SCREEN

Ensure the Start screen is showing

1



Insert the USB memory stick into the socket on the side of the oven panel. (Rubber plug may have to be removed first).

2

NOTE

The USB stick will only fit in one way.
Do not force into the socket.



Wait for the USB symbol to finish moving

3

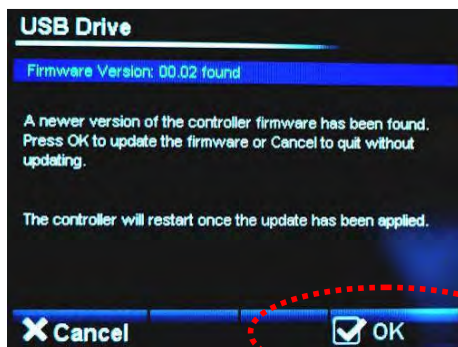

If old firmware is found, the firmware version screen will appear.

Touch "OK" to update firmware

-Wait-

Remove USB stick

OR

Touch CANCEL to choose other items to update or change.
(see next page)

4

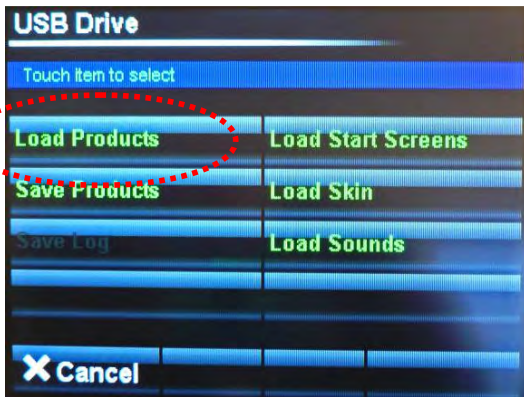

Choose action you would like to do. **5**



Select the file required. **6**

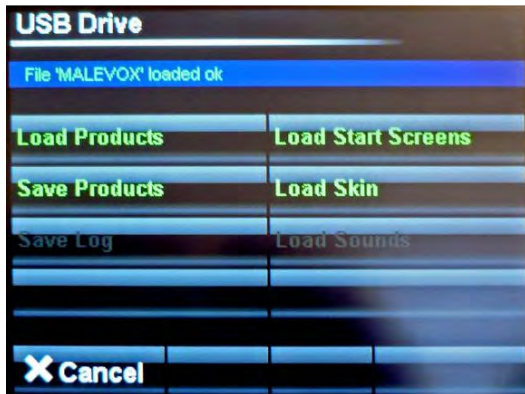

When confirmation of **“file loaded ok”** shows, remove usb stick

NOTES ON USING USB STICKS

For a USB stick to function correctly it must have the following folder in the root folder .

Mono

Then into that folder add the following:

Firmware
Products
Skins
Sounds
Startup

Place your recipe/product files in the “**products**” folder.

The oven will find the “**Mono**” folder automatically when the stick is plugged into the oven.
Any stick can be used (does not have to be blank) but the Mono folder must be in the root folder.

The most used folders are explained below:

SKINS

These control the way the screen looks in different modes.

Pictorial is when the screen displays categories using pictures.



Numerical is when the screen displays program numbers.



STARTUP SCREENS

This is the picture/logo you see when the oven is started.



PRODUCT FILES (PROGRAM FILES)

These are the files that contain the information for baking each product e.g. bread,buns,cakes etc.

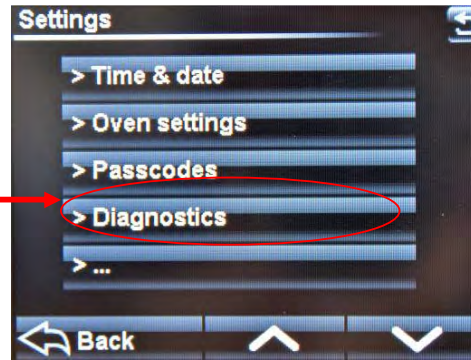

SETTINGS SCREEN

TOUCH "DIAGNOSTICS" AND THE FOLLOWING SCREEN WILL APPEAR.

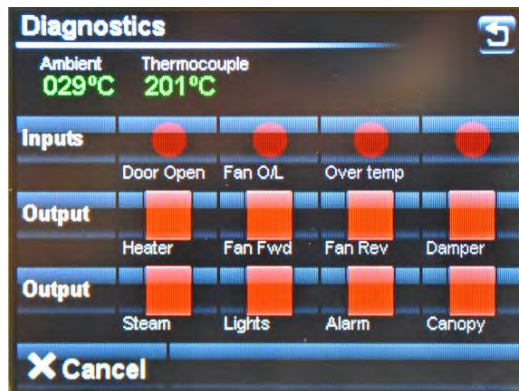

DIAGNOSTICS SCREEN

INPUTS HIGHLIGHT WHEN A SIGNAL IS Received.
e.g. DOOR OPEN

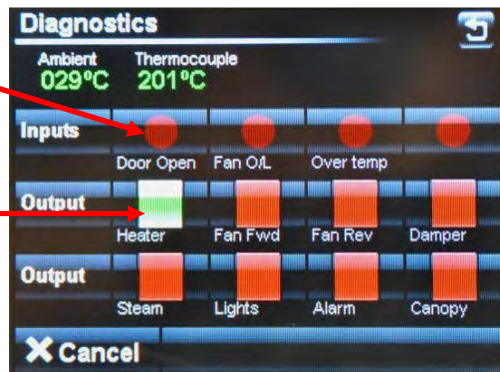

TOUCH THE REQUIRED OUTPUT AND A SIGNAL IS SENT TO THAT ITEM. THE OUTPUT BEING CHECKED IS HIGHLIGHTED WHEN ACTIVE. TO STOP THE OUTPUT, TOUCH AGAIN.

9.0 MAINTENANCE

- Check for frayed or bare cables.
The machine must not be used if frayed or bare cables are visible.
- Follow cleaning instructions.

10.0 STEAM SYSTEM MAINTENANCE

- If it is noticed that the steaming operation has deteriorated, perhaps due to hard water scaling, please contact your oven supplier

11.0 BULB REPLACEMENT

In the event of a bulb failure, Instructions on how to change a bulb are as follows: -

- Ensure oven is isolated from mains supply and allow to cool.
- Remove screws (4 per light) and take glass, frame and gasket off lamp unit.

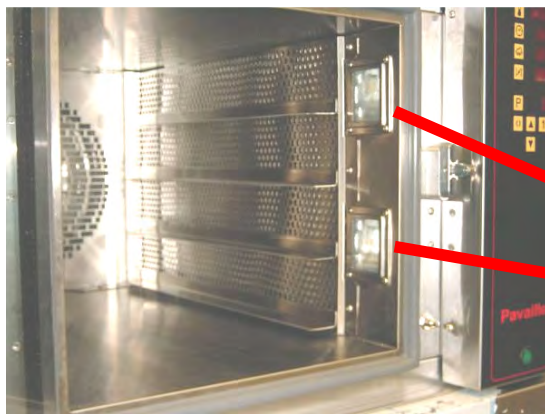

SCREWS

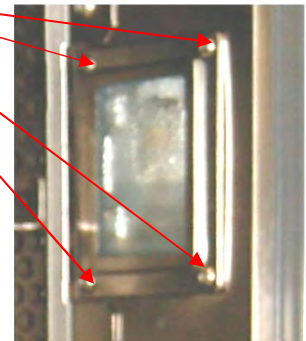

- Remove bulb by pulling in direction of arrow and replace with new bulb.

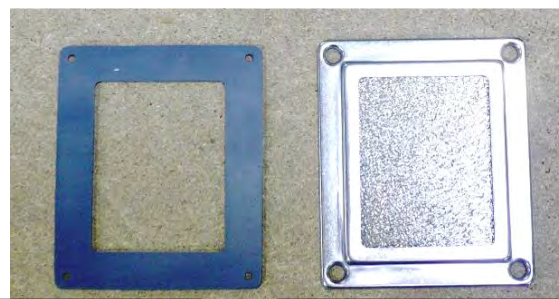

GASKET

Pt No.B721-67-008

GLASS AND FRAME

Pt No.B721-67-010

Pt No.B721-67-009

- Refit glass front, taking care that gasket is in position around stainless steel frame.
Re-connect oven and test.

DO NOT TOUCH BULBS WITH BARE HANDS.
USE A CLOTH OR GLOVES TO STOP ANY MARKS THAT WILL CAUSE HOT SPOTS AND PREMATURE BULB FAILURE.

12.0

SPARES

When ordering spares please quote the **machine serial number** which can be found on the silver information plate of the machine and on the front cover of this manual.

MACHINE SERIAL NUMBER



PART 1

FG150 10 TRAY OVEN SPARES SECTION

PART 2

FG159 4/5 TRAY 18 X 30 OVEN SPARES SECTION

PART 3

FG158 4/5 TRAY 60 X 40 OVEN SPARES SECTION

PART 4

FG153 4/5 TRAY 40 X 60 OVEN SPARES SECTION

[email:spares@monoequip.com](mailto:spares@monoequip.com)

Spares +44(0)1792 564039

PART 1 10 TRAY OVEN SPARES SECTION

FG150

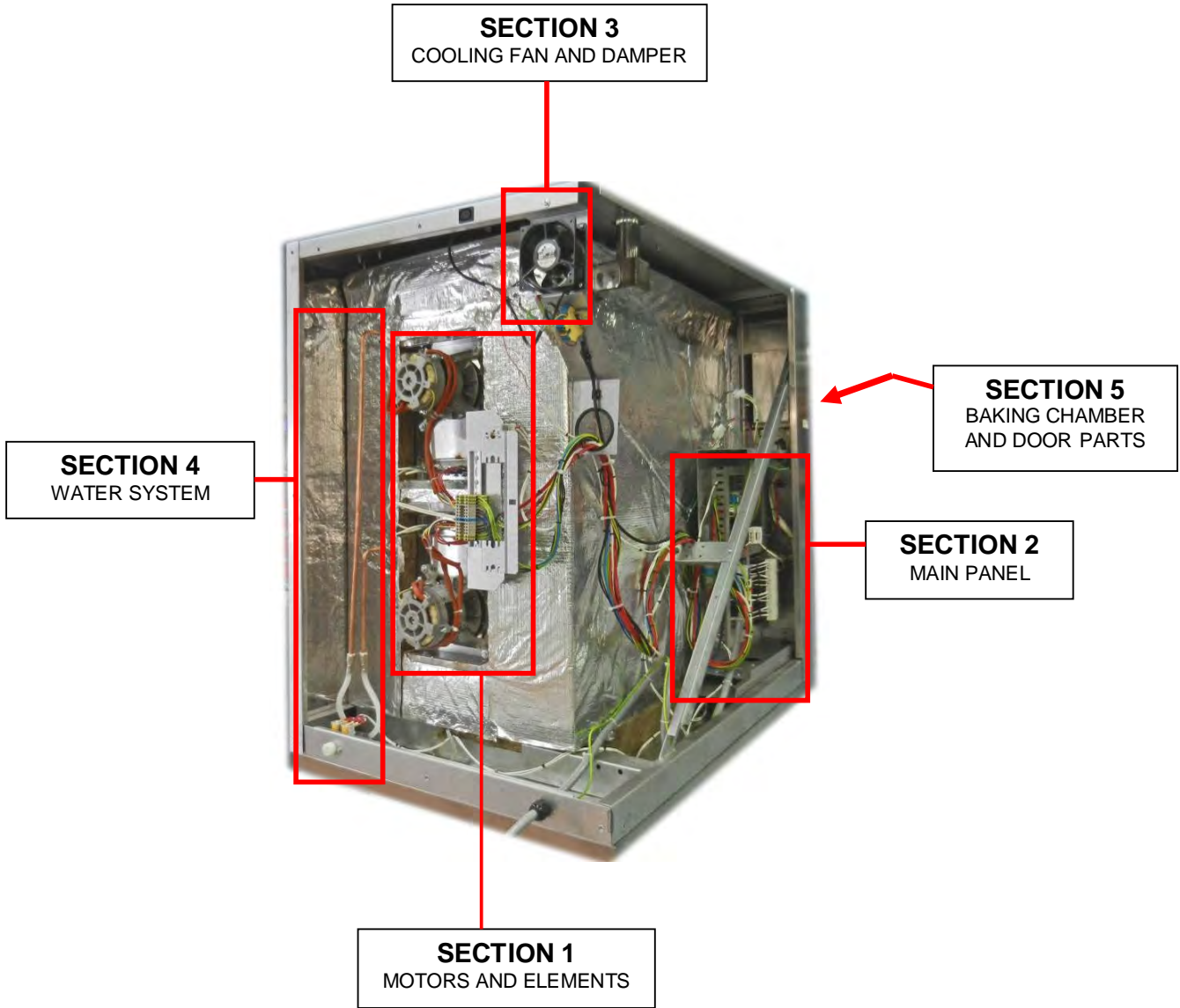

REAR VIEW WITH OUTER SHEETING REMOVED

PART 1 / SECTION 1 – 10 TRAY - MOTORS AND ELEMENTS

FG150

8Kw ovens

HEATING ELEMENT – B847-04-068 = 240volts
B847-04-073 = 220volts

PART 30

7Kw ovens

HEATING ELEMENT – B847-04-067 = 240volts
B847-04-074 = 220volts

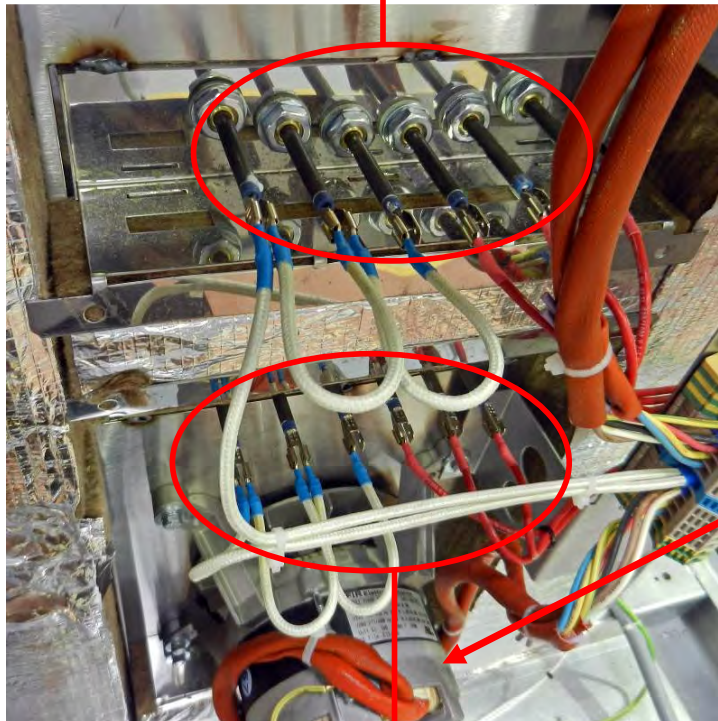

PART 18

PART 19

TOP NOT SHOWN

FAN MOTORS - B720-74-001

8Kw ovens

HEATING ELEMENT – B847-04-068 = 240volts
B847-04-073 = 220volts

PART 31

7Kw ovens

HEATING ELEMENT – B847-04-067 = 240volts
B847-04-074 = 220volts

PART NUMBERS REFER TO DRAWING M1500E25-75100 IN ELECTRICAL MANUAL

FG150

PART 21

OVERHEAT THERMOSTAT – B888-30-014

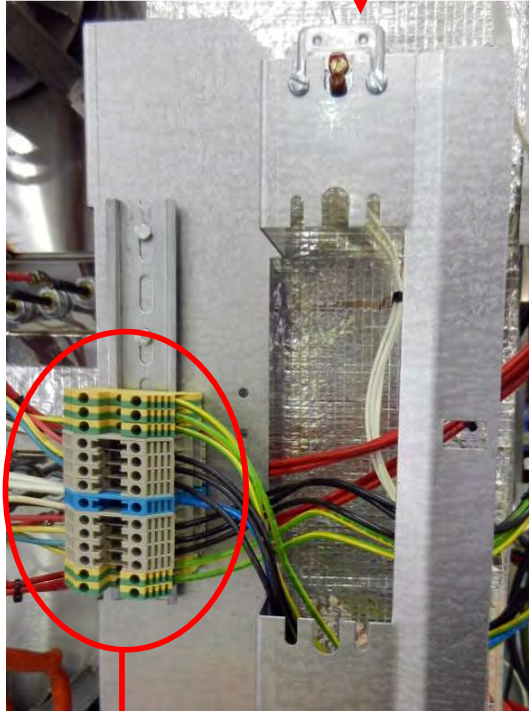

TB3

MOTOR AND ELEMENT CONNECTIONS

PART NUMBERS REFER TO DRAWING M1500E25-75100 IN ELECTRICAL MANUAL

PART 1 / SECTION 2 – 10 TRAY - MAIN PANEL

FG150

PT-4A FAN MOTOR OVERLOAD
B801-03-020
PT4B FAN MOTOR OVERLOAD AUX. CONTACTOR
B801-14-012

PT-5A FAN MOTOR OVERLOAD
B801-03-020
PT5B FAN MOTOR OVERLOAD AUX. CONTACTOR
B801-14-012

PART 1
INTERIOR LIGHTING MCB
B872-22-063

PART 2
CONTROL CIRCUIT MCB
B872-22-062

PART 15
HEATING ELEMENT CONTACTOR
B801-08-020

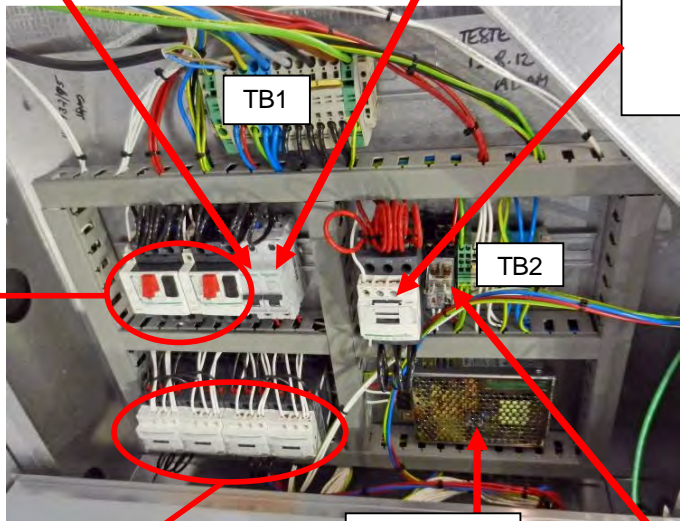

PART 14
24v DC POWER SUPPLY UNIT
B801-93-005

FAN MOTOR CONTACTORS
B801-08-031
PT-10A (TOP FORWARD)
PT-10B (TOP REVERSE)
PT-11A (BTM FORWARD)
PT-11B (BTM REVERSE)

INTERLOCK UNIT X2
B801-18-005

PT-8A INTERIOR LIGHT RELAY
B723-37-004
PT8B INTERIOR LIGHT RELAY BASE
B723-36-001

PART NUMBERS REFER TO DRAWING M1500E25-75100 IN ELECTRICAL MANUAL

PART 1 / SECTION 3 – 10 TRAY - COOLING FAN AND DAMPER

FG150

DAMPER BRACKET 150-02-01000

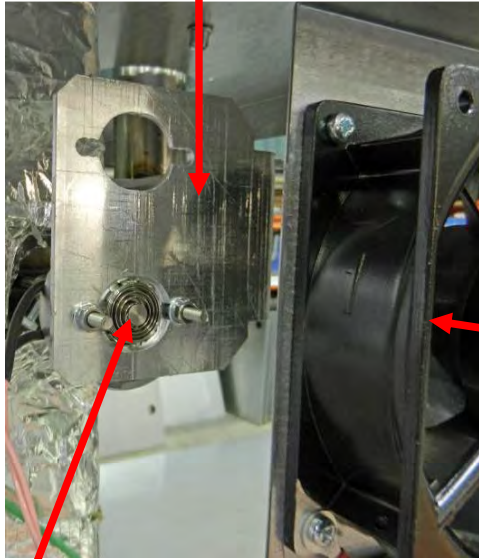

PART 34

**REAR FAN UNIT
B869-75-018**



PART 37

**AUX. POWER OUTLET FUSE
B842-85-039**

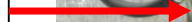

PART 17

**DAMPER SOLENOID L/H OVEN B749-83-003
DAMPER SOLENOID R/H OVEN B749-83-004**

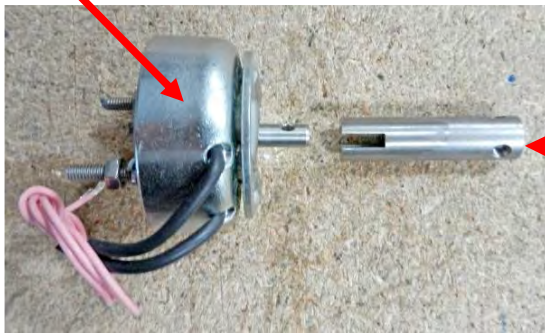

PART 35

**REAR FAN UNIT FUSE
B842-85-025**

**COUPLING
158-02-00600**



PART NUMBERS REFER TO DRAWING M1500E25-75100 IN ELECTRICAL MANUAL

PART 1 / SECTION 4 – 10 TRAY – WATER/STEAM SYSTEM

FG150

DELIVERY PIPE - LONG
150-07-00800

DELIVERY PIPE - SHORT
150-07-00700

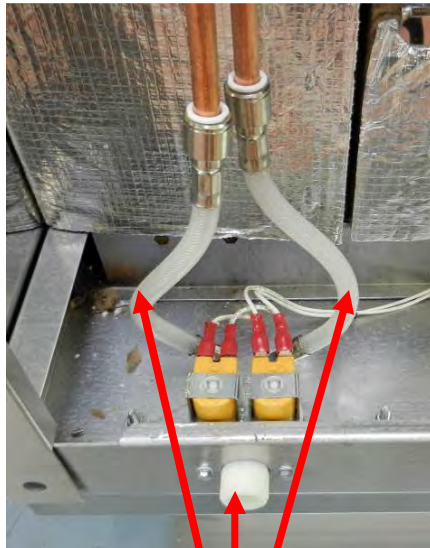

PART 20

WATER SOLENOID (INC. HOSES)
150-07-00400

HOSE – BLUE (NOT SHOWN ATTACHED)
A900-34-087



PART 1 / SECTION 4 – 10 TRAY – WATER/STEAM SYSTEM

FG150

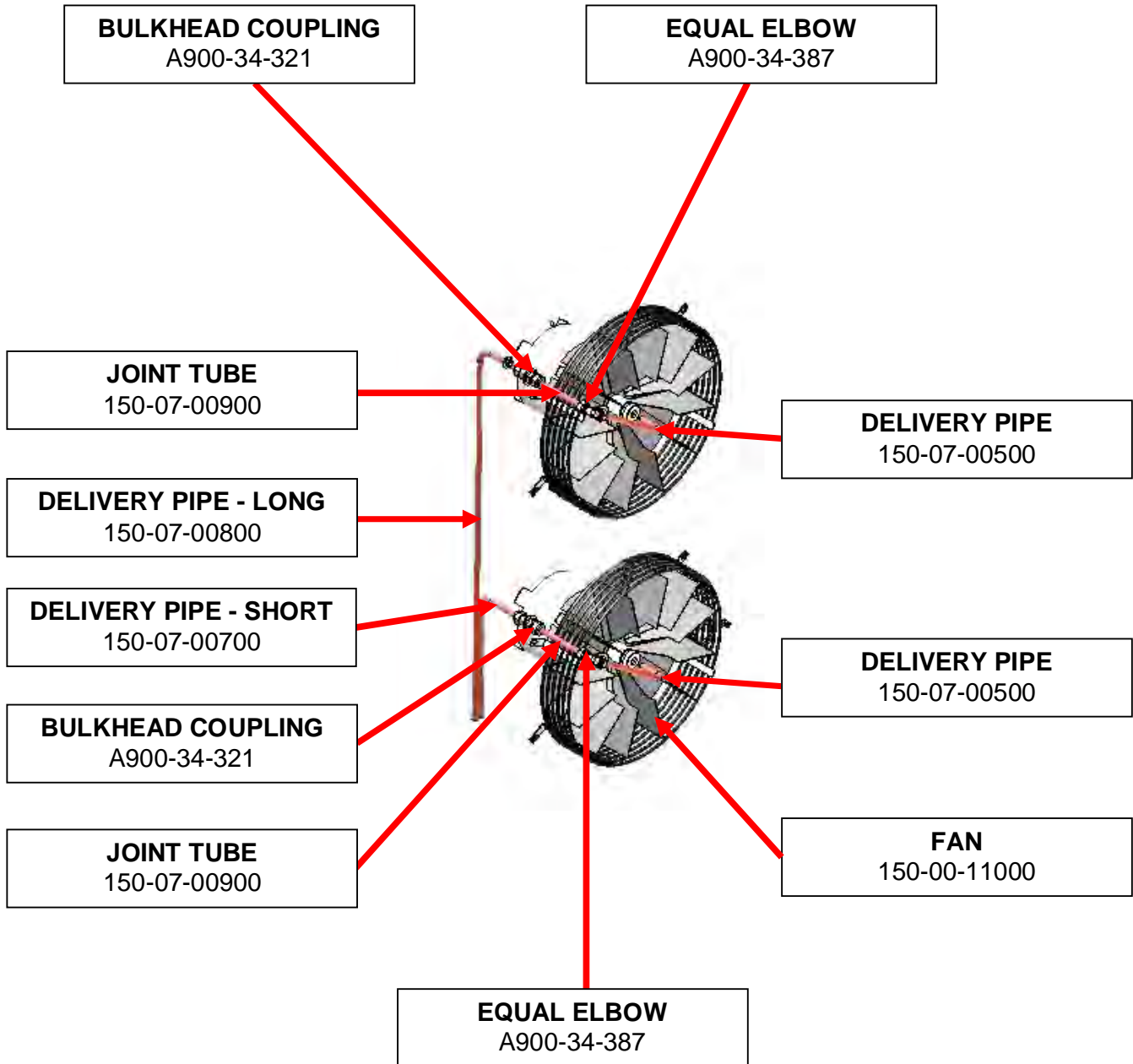

COMPLETE STEAM ASSY KIT = PT No. 150-07-00003

INCLUDES 150-01-07700 PIPE GUIDE BRKT X 2
AND 150-07-00400 DOUBLE SOLENOID INLET VALVE.

PART 1 / SECTION 5 – 10 TRAY - BAKING CHAMBER AND DOOR PARTS

FG150

TOP HINGE LH OVEN PT No.150-03-05400
TOP HINGE RH OVEN PT No.150-03-04700

DOOR SEAL
PT No.150-03-02500

OUTER DOOR GLASS
PT No.150-03-09900

INNER DOOR GLASS
PT No.150-03-10100

SIDE SHEET LH
PT No.150-01-07201
(FIXED RUNNERS NOT SHOWN)

SIDE SHEET RH
PT No.150-01-07200
(FIXED RUNNERS NOT SHOWN)

FAN
PT No.150-00-11000

REAR SHEET
PT No.150-01-06700

BOTTOM HINGE LH OVEN PT No.150-03-04700
BOTTOM HINGE RH OVEN PT No.150-03-05400



DOOR SWITCH
PT No.B842-07-023

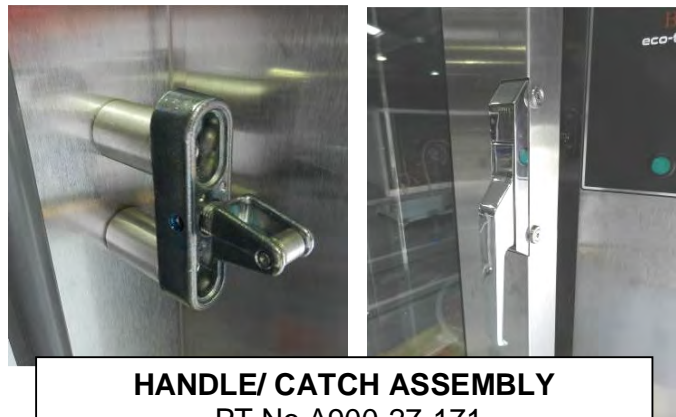

HANDLE/ CATCH ASSEMBLY
PT No.A900-27-171

COMPLETE DOOR ASSEMBLY = PT No 150-03-09500 LH AND RH (STATE WHICH REQ'D)

FG150

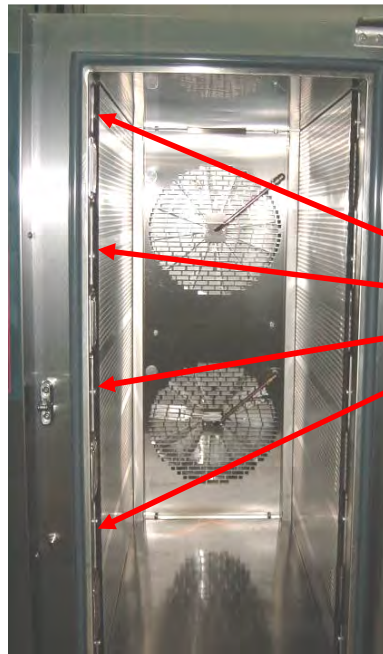

**LIGHT ASSEMBLY
PT No.B721-67-011**

INDIVIDUAL LIGHT ASSEMBLY PARTS AVAILABLE AS BELOW



REPLACEMENT BULB = B857-94-007



GASKET

Pt. No.B721-67-008



GLASS AND FRAME

Pt. No.B721-67-010

Pt. No.B721-67-009

DO NOT TOUCH BULBS WITH BARE HANDS.
USE A CLOTH OR GLOVES TO STOP ANY MARKS THAT WILL CAUSE HOT SPOTS AND PREMATURE BULB FAILURE.

PART 2 4/5 TRAY 18 X 30 OVEN SPARES SECTION

FG159

SECTION 3
DAMPER

SECTION 1
MOTOR AND ELEMENT

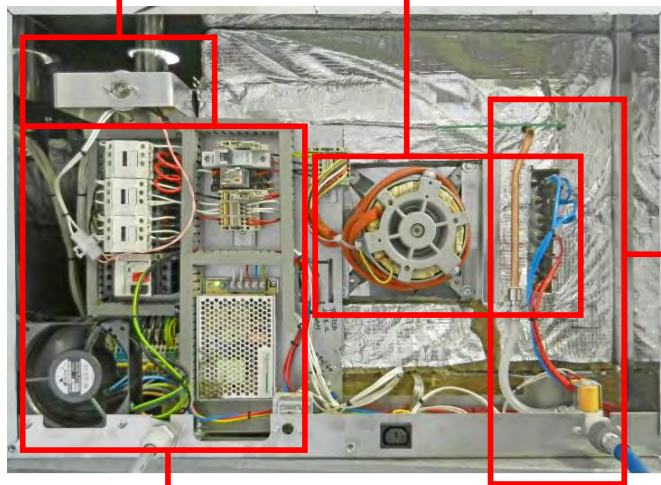

SECTION 4
WATER SYSTEM

SECTION 2
MAIN PANEL

SECTION 5
BAKING CHAMBER
AND DOOR PARTS

PART NUMBERS REFER TO DRAWING M159E25-75000 IN ELECTRICAL MANUAL

FG159

PART 10

FAN MOTOR UNIT – B720-74-001

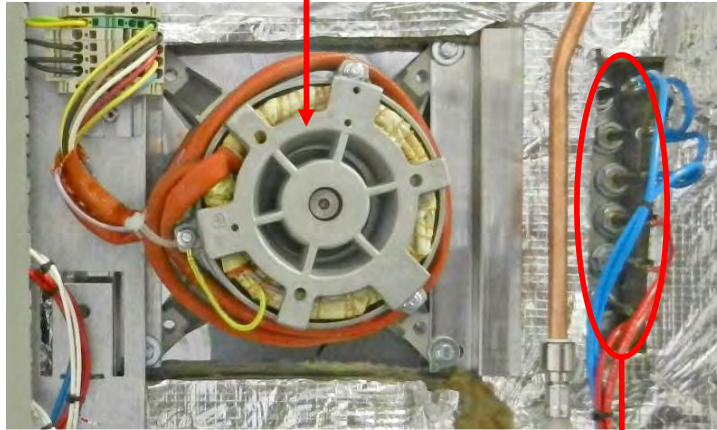

PART 11

**HEATING ELEMENT – B847-04-068 = 240volts
B847-04-073 = 220volts**

PART NUMBERS REFER TO DRAWING M159E25-75000 IN ELECTRICAL MANUAL

PART 2 / SECTION 2 – 4/5 TRAY 18 X 30 – MAIN PANEL

FG159

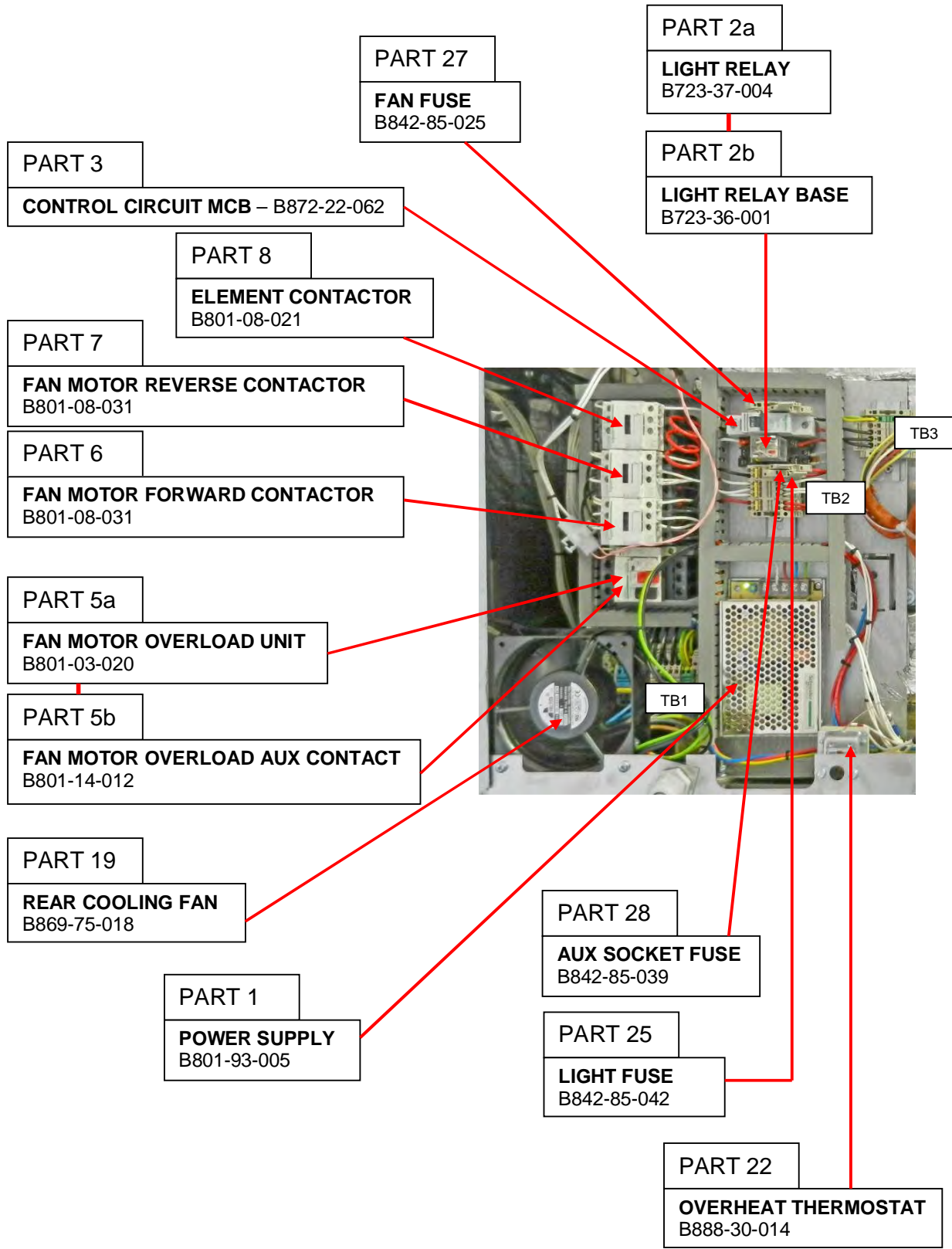

PART NUMBERS REFER TO DRAWING M159E25-75000 IN ELECTRICAL MANUAL

PART 2 / SECTION 3 – 4/5 TRAY 18 X 30 – DAMPER

FG159

PART 9

DAMPER SOLENOID L/H OVEN B749-83-003
DAMPER SOLENOID R/H OVEN B749-83-004

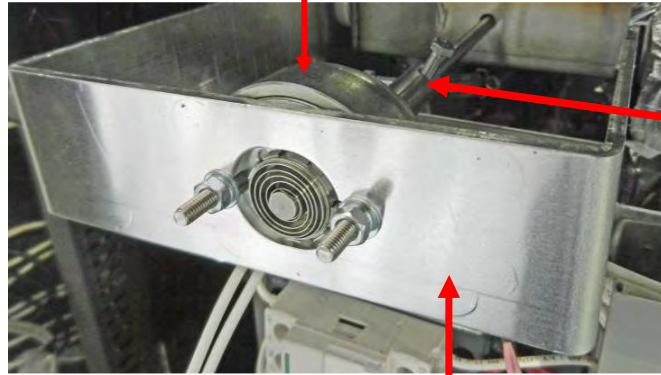

DAMPER SOLENOID BRKT
158-02-00300

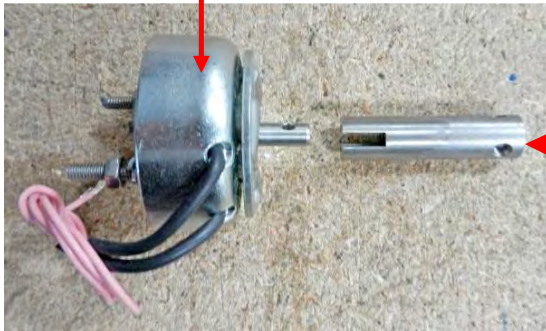

COUPLING
158-02-00600

PART NUMBERS REFER TO DRAWING M159E25-75000 IN ELECTRICAL MANUAL

FG159

BULKHEAD COUPLING
A900-34-321
(UNDER INSULATION)

COPPER PIPE
A900-34-253
(10mm OD X 20 swg)

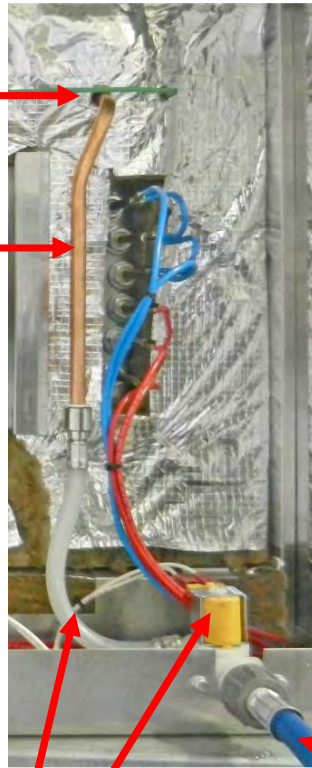

HOSE – BLUE
A900-34-087

PART 12

WATER INLET ASSY (INC. HOSE)
158-17-00400

PART NUMBERS REFER TO DRAWING M159E25-75000 IN ELECTRICAL MANUAL

PART 2 / SECTION 4 – 4/5 TRAY 18 X 30 – WATER/STEAM SYSTEM

FG159

EQUAL ELBOW
A900-34-387

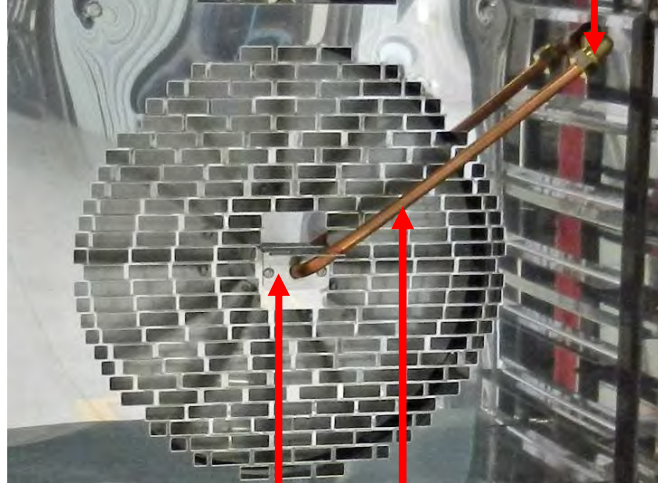

PIPE GUIDE BRACKET
150-01-07700

INDIVIDUAL PART NUMBERS ARE NOT AVAILABLE FOR PIPES. ALL PIPES MADE FROM A900-34-253 COPPER PIPE 10mm O/D X 20swg WALL

BULKHEAD COUPLING
A900-34-321

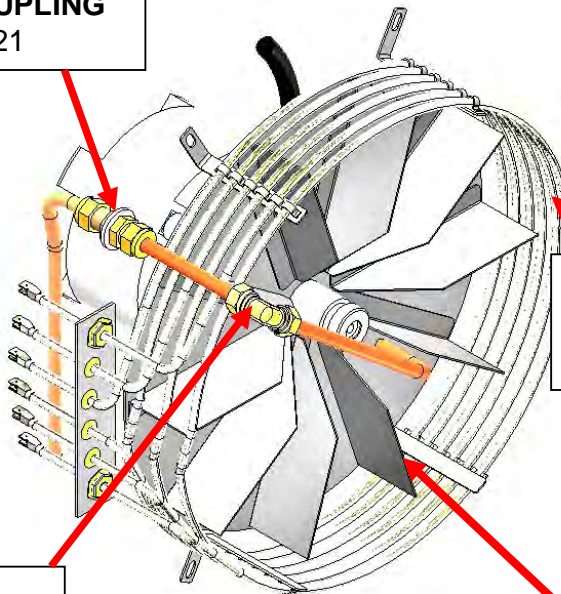

HEATING ELEMENT
B847-04-068 = 240volts
B847-04-073 = 220volts

EQUAL ELBOW
A900-34-387

FAN
150-00-11000

PART 2 / SECTION 5 – 4/5 TRAY 18 X 30 BAKING CHAMBER AND DOOR PARTS

FG159

TOP HINGE LH OVEN PT No.158-03-10501

TOP HINGE RH OVEN PT No.158-03-10500

DOOR SEAL

PT No.159-03-01500

REAR SHEET

PT No.159-01-10900

OUTER DOOR GLASS

PT No.159-03-04200

FAN

PT No.150-00-11000

INNER DOOR

INCLUDING GLASS

PT No.159-03-10200

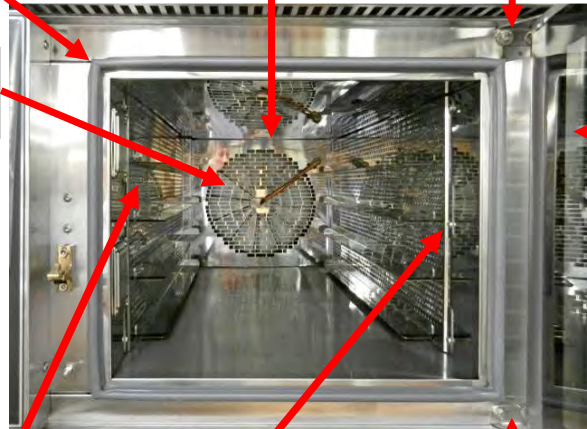

LH FIXED RUNNERS 4 TRAY

PT No.159-01-05000

LH FIXED RUNNERS 5 TRAY

PT No.159-01-05200

BOTTOM HINGE LH OVEN PT No.158-03-10500

BOTTOM HINGE RH OVEN PT No.158-03-10501

RH FIXED RUNNERS 4 TRAY

PT No.159-01-05001

RH FIXED RUNNERS 5 TRAY

PT No.159-01-05201



DOOR SWITCH

PT No.B842-07-023



HANDLE/ CATCH ASSEMBLY

PT No.A900-27-118



COMPLETE DOOR ASSEMBLY = PT No 159-03-04000 = LH HINGE DOOR
PT No 159-03-04001 = RH HINGE DOOR

FG159

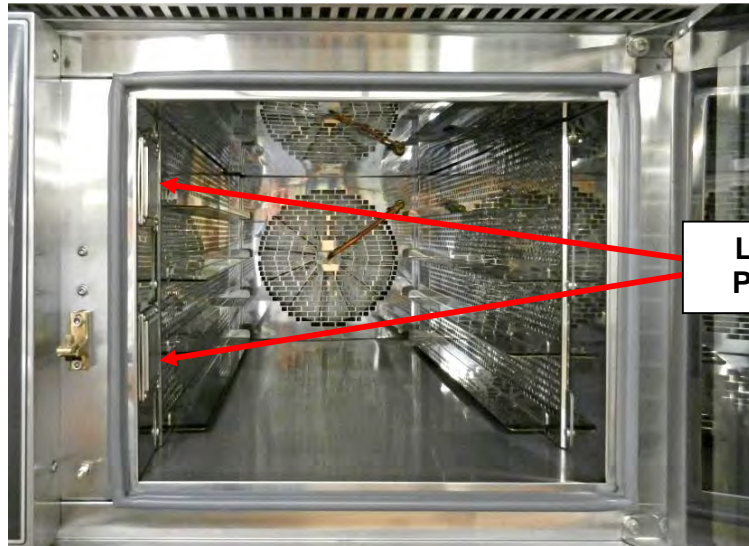

**LIGHT ASSEMBLY
PT No.B721-67-011**

INDIVIDUAL LIGHT ASSEMBLY PARTS AVAILABLE AS BELOW



REPLACEMENT BULB = B857-94-007



GASKET

Pt No.B721-67-008

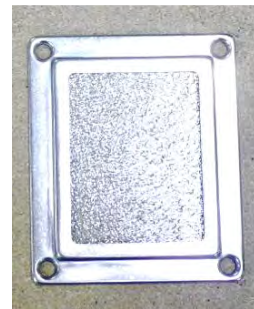

GLASS AND FRAME

Pt No.B721-67-010

Pt No.B721-67-009

DO NOT TOUCH BULBS WITH BARE HANDS.
USE A CLOTH OR GLOVES TO STOP ANY MARKS THAT WILL CAUSE HOT SPOTS AND PREMATURE BULB FAILURE.

PART 3

4/5 TRAY 60 X 40 OVEN SPARES SECTION

FG158

SECTION 3
DAMPER AND FAN

SECTION 1
MOTOR AND ELEMENT

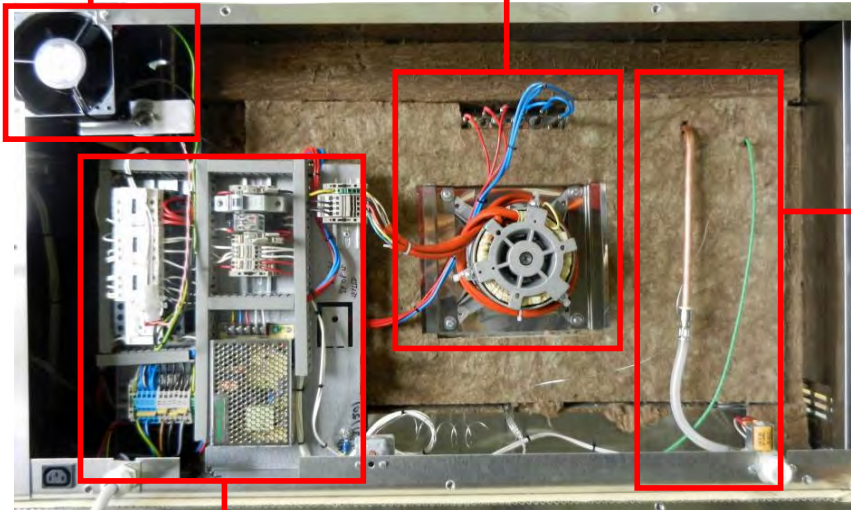

SECTION 4
WATER SYSTEM

SECTION 2
MAIN PANEL

SECTION 5
BAKING CHAMBER
AND DOOR PARTS

FG158

**PART 11 HEATING ELEMENT – B847-04-067 = 240volts
B847-04-074 = 220volts**

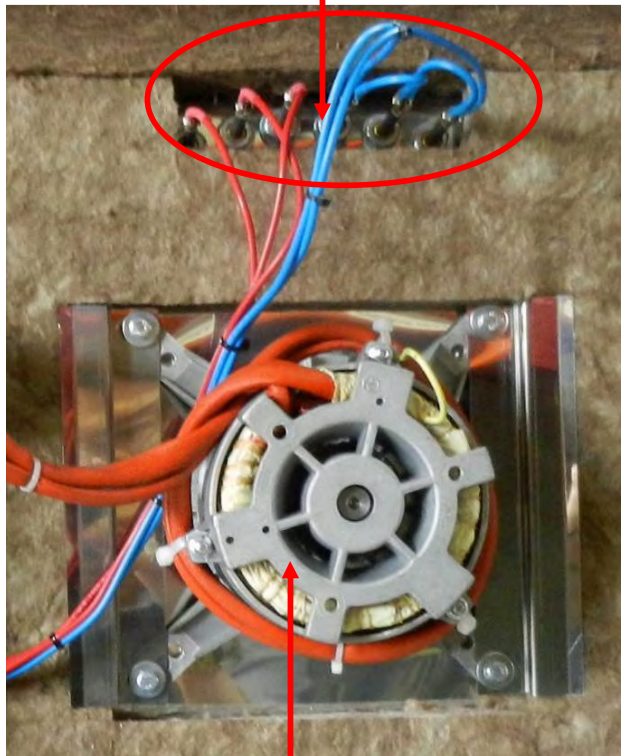

PART 10 FAN MOTOR UNIT – B720-74-001

PART NUMBERS REFER TO DRAWING M158E25-75200 IN ELECTRICAL MANUAL

PART 3 / SECTION 2 – 4/5 TRAY 60 X 40 – MAIN PANEL

FG158

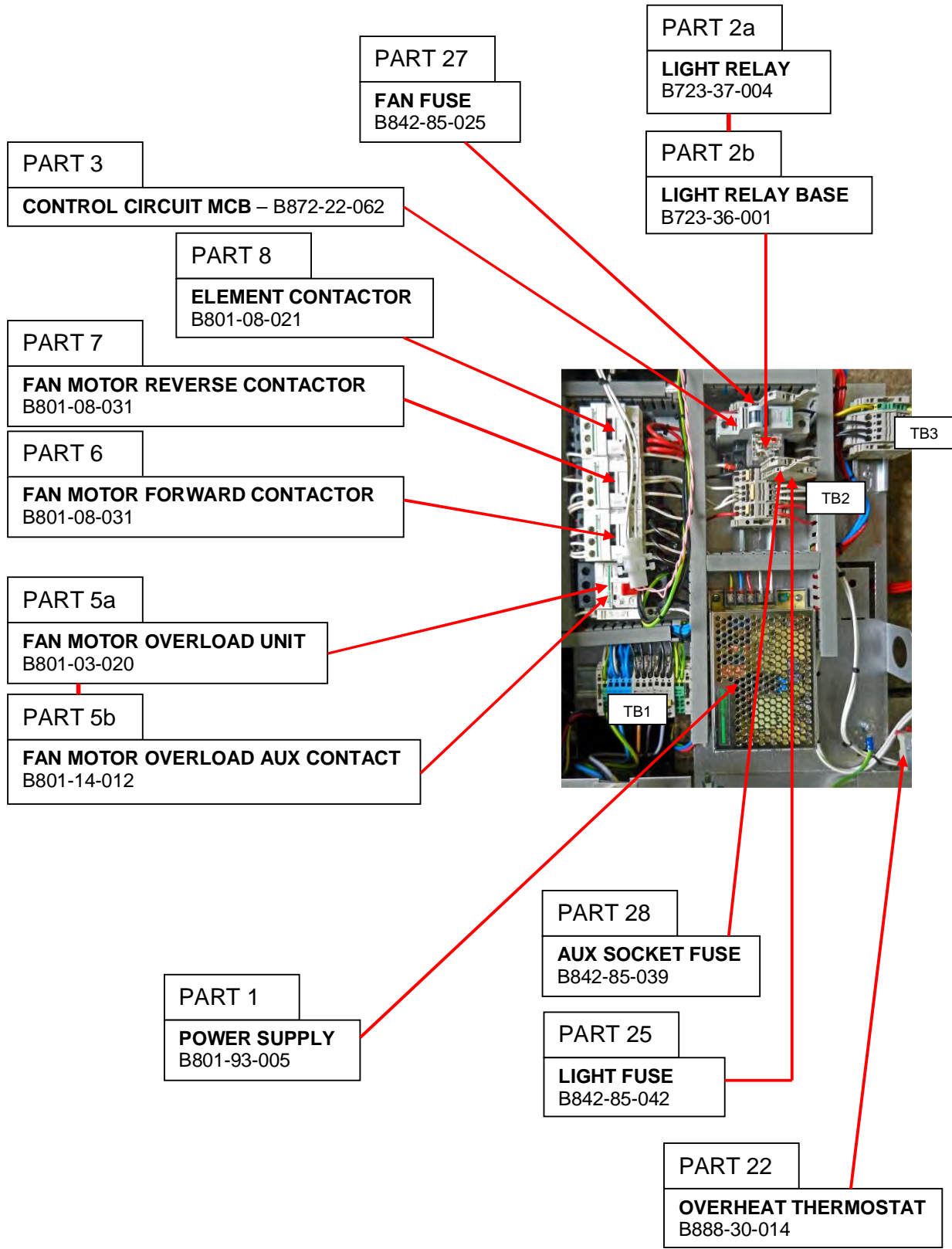

PART NUMBERS REFER TO DRAWING M158E25-75200 IN ELECTRICAL MANUAL

FG158

PART 9

DAMPER SOLENOID L/H OVEN B749-83-003
DAMPER SOLENOID R/H OVEN B749-83-004

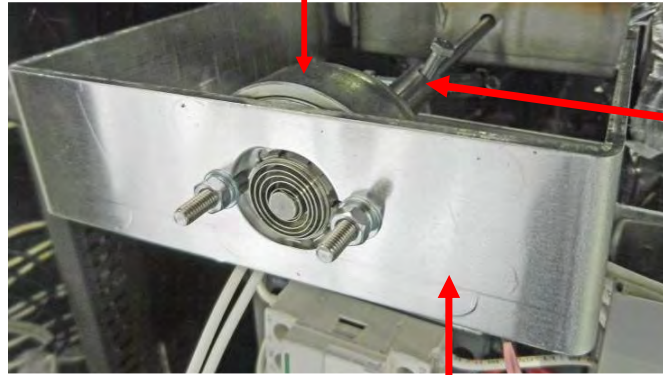

DAMPER SOLENOID BRKT
158-02-00300

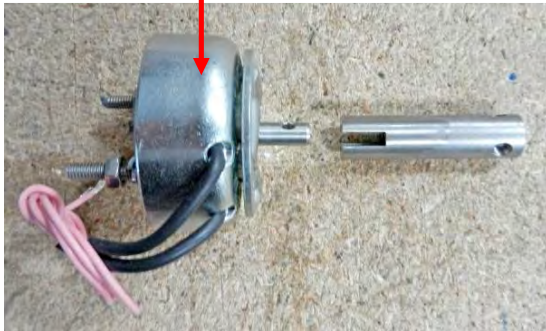

COUPLING
158-02-00600

PART 19

REAR COOLING FAN
B869-75-018

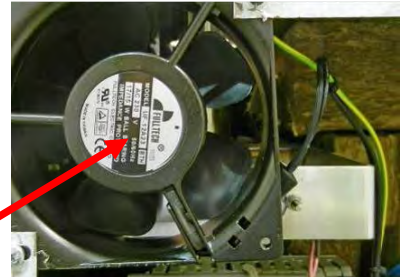

PART NUMBERS REFER TO DRAWING M159E25-75200 IN ELECTRICAL MANUAL

PART 3 / SECTION 4 – 4/5 TRAY 60 X 40 – WATER/STEAM SYSTEM

FG158

BULKHEAD COUPLING
A900-34-321
(UNDER INSULATION)

COPPER PIPE
A900-34-253
(10mm OD X 20 swg)

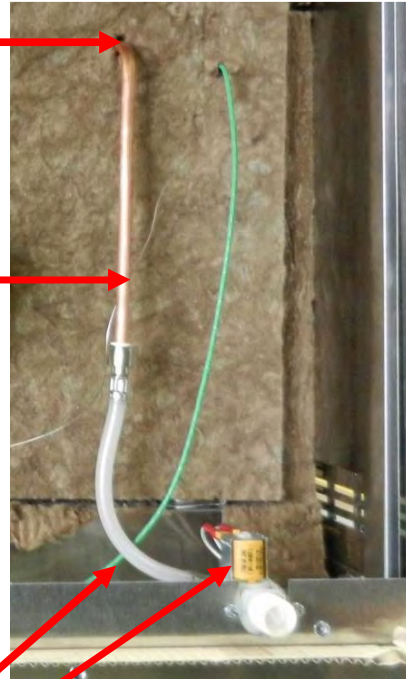

PART 12

WATER INLET ASSY (INC. HOSE)
158-17-00400

HOSE – BLUE (NOT SHOWN)
A900-34-087

PART NUMBERS REFER TO DRAWING M159E25-75200 IN ELECTRICAL MANUAL

FG158

EQUAL ELBOW
A900-34-387

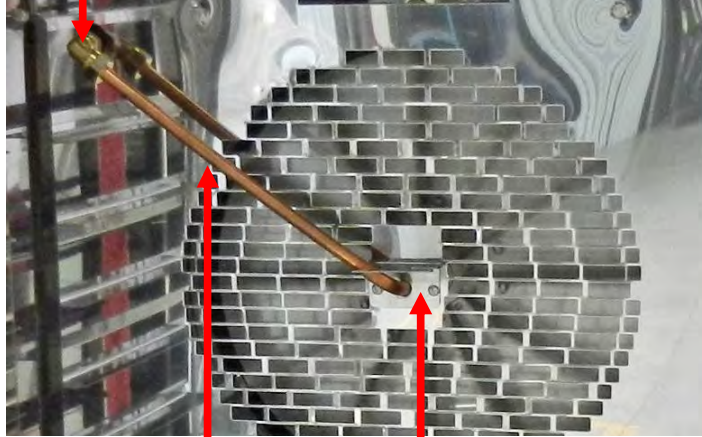

INDIVIDUAL PART NUMBERS ARE NOT AVAILABLE FOR PIPES. ALL PIPES MADE FROM A900-34-253 COPPER PIPE 10mm O/D X 20swg WALL

PIPE GUIDE BRACKET
150-01-07700

HEATING ELEMENT
B847-04-067 = 240volts
B847-04-074 = 220volts

BULKHEAD COUPLING
A900-34-321

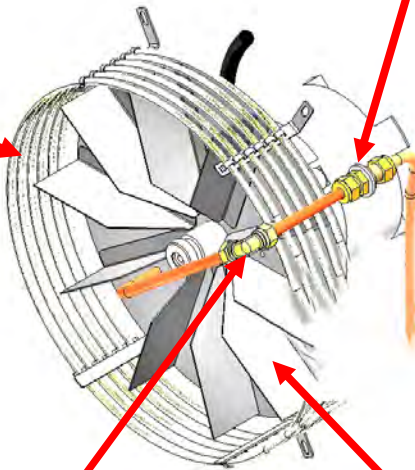

EQUAL ELBOW
A900-34-387

FAN
150-00-11000

PART 3 / SECTION 4 – 4/5 TRAY 60 X 40 BAKING CHAMBER AND DOOR PARTS

FG158

TOP HINGE LH OVEN PT No.158-03-10501

TOP HINGE RH OVEN PT No.158-03-10500

DOOR SEAL

PT No.158-03-01500

REAR SHEET

PT No.158-01-11200

FAN

PT No.158-00-11000

**OUTER/INNER
DOOR GLASS**

PT No.158-03-03600

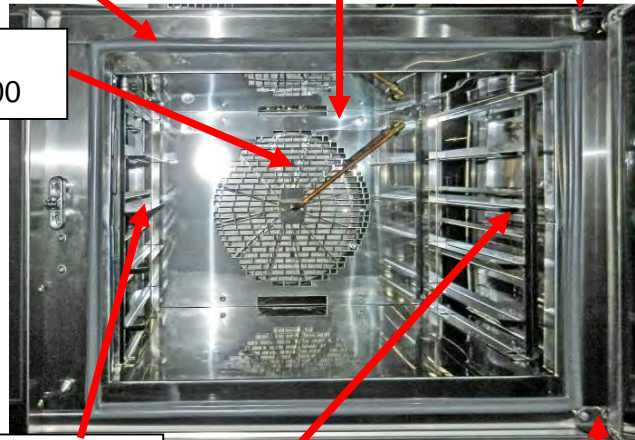

LH RUNNER RACK 4/5 TRAY

PT No.158-04-01000

RH RUNNER RACK 4/5 TRAY

PT No.158-04-01001

BOTTOM HINGE LH OVEN PT No.158-03-10500

BOTTOM HINGE RH OVEN PT No.158-03-10501

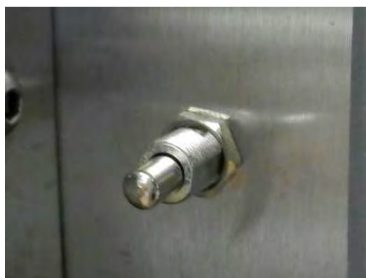

DOOR SWITCH

PT No.B842-07-023



HANDLE/ CATCH ASSEMBLY

PT No.A900-27-171

COMPLETE DOOR ASSEMBLY = PT No 158-03-03400 = LH HINGE DOOR

PT No 158-03-03401 = RH HINGE DOOR

FG158

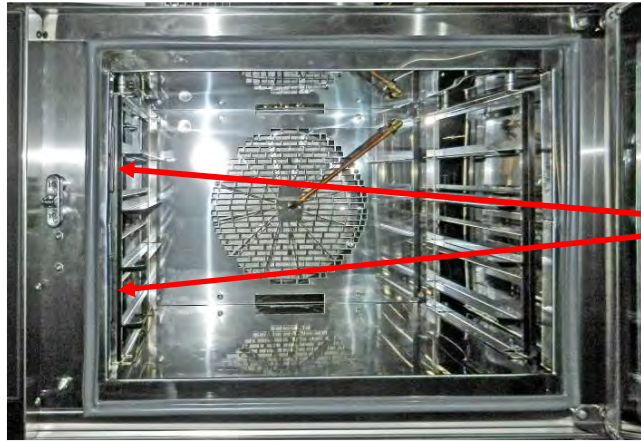

**LIGHT ASSEMBLY
PT No.B721-67-011**

INDIVIDUAL LIGHT ASSEMBLY PARTS AVAILABLE AS BELOW



REPLACEMENT BULB = B857-94-007



GASKET

Pt. No.B721-67-008

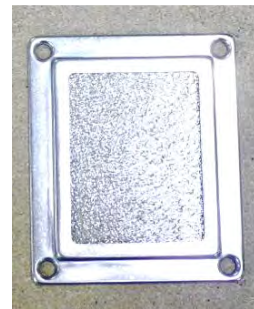

GLASS AND FRAME

Pt. No.B721-67-010

Pt. No.B721-67-009

DO NOT TOUCH BULBS WITH BARE HANDS.
USE A CLOTH OR GLOVES TO STOP ANY MARKS THAT WILL CAUSE HOT SPOTS AND PREMATURE BULB FAILURE.

PART 4 4/5 TRAY 40 X 60 OVEN SPARES SECTION

FG153

SECTION 3
DAMPER

SECTION 1
MOTOR AND ELEMENT

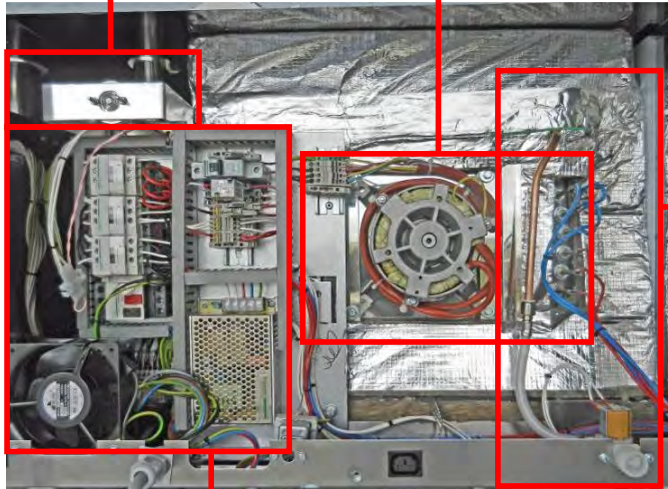

SECTION 4
WATER SYSTEM

SECTION 2
MAIN PANEL

SECTION 5
BAKING CHAMBER
AND DOOR PARTS

FG153

PART 11

**HEATING ELEMENT – B847-04-067 = 240volts
B847-04-074 = 220volts**

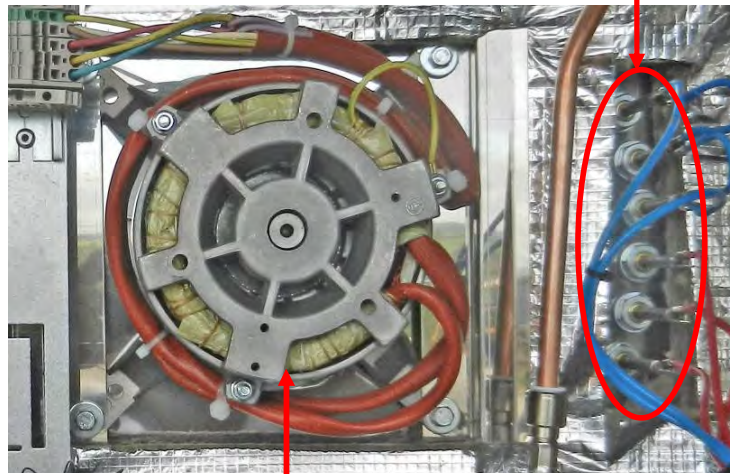

PART 10

FAN MOTOR UNIT – B720-74-001

PART NUMBERS REFER TO DRAWING M158E25-75200 IN ELECTRICAL MANUAL

PART 4 / SECTION 2 – 4/5 TRAY 40 X 60 – MAIN PANEL

FG153

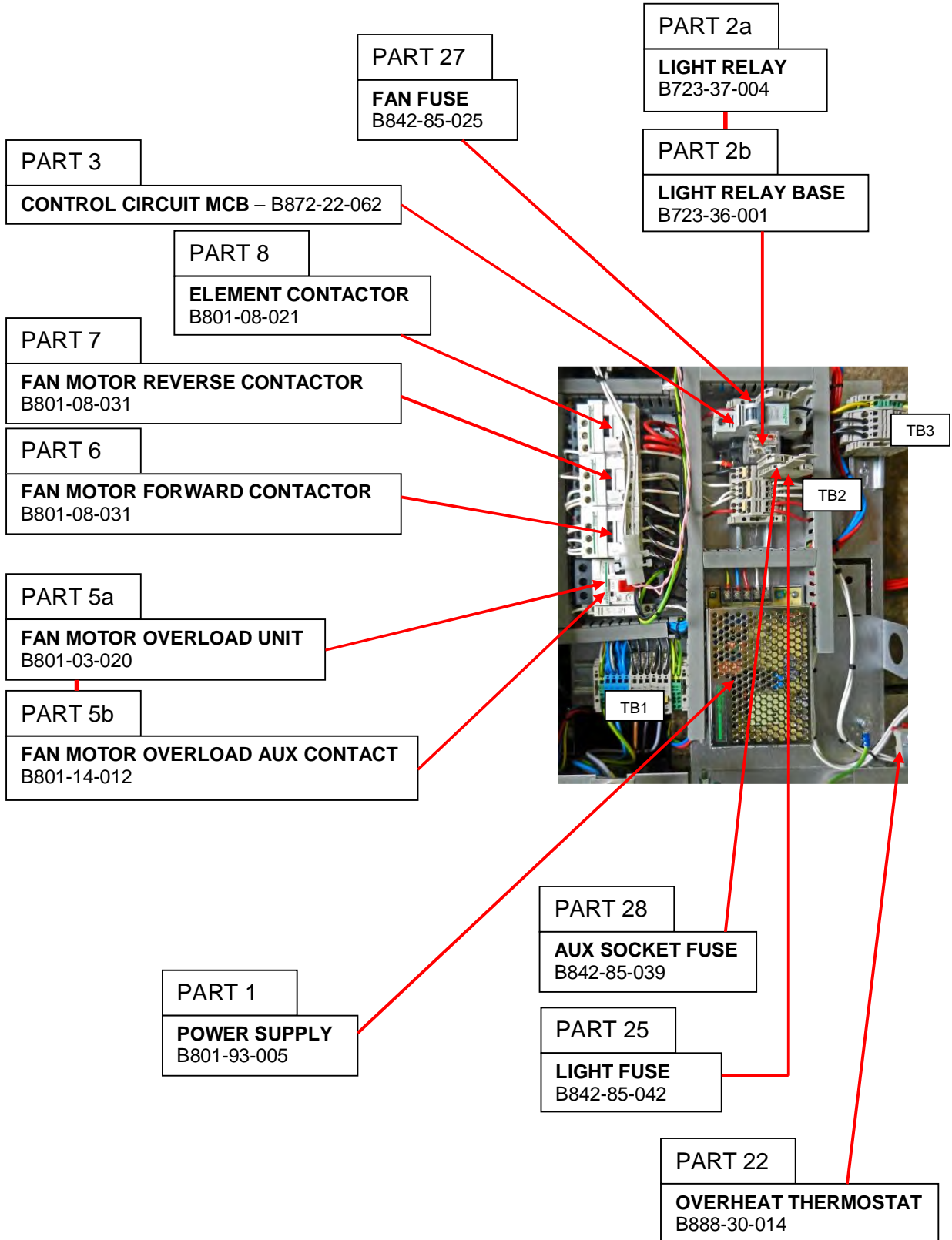

PART NUMBERS REFER TO DRAWING M158E25-75200 IN ELECTRICAL MANUAL

PART 4 / SECTION 3 – 4/5 TRAY 40 X 60 – DAMPER AND COOLING FAN

FG153

PART 9

DAMPER SOLENOID L/H OVEN B749-83-003
DAMPER SOLENOID R/H OVEN B749-83-004

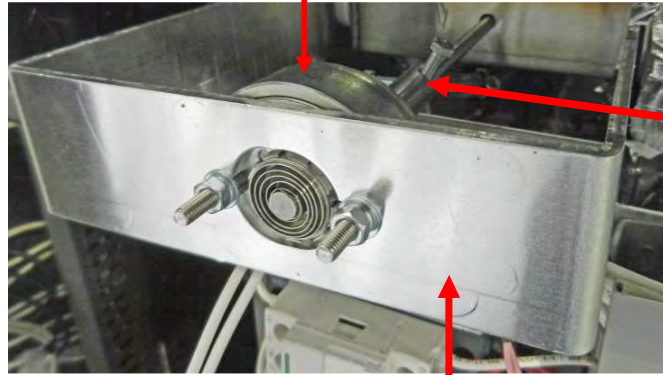

DAMPER SOLENOID BRKT
158-02-00300

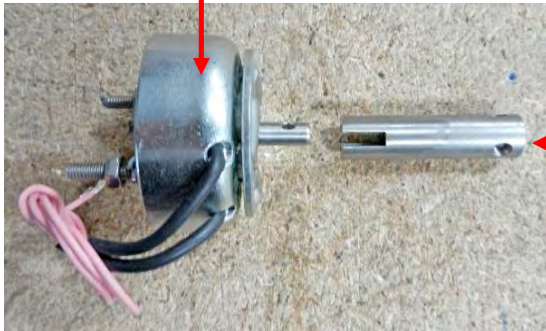

COUPLING
158-02-00600

PART 19

REAR COOLING FAN
B869-75-018

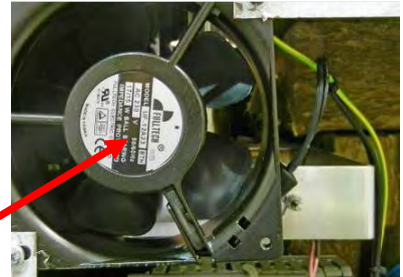

PART NUMBERS REFER TO DRAWING M158E25-75200 IN ELECTRICAL MANUAL

PART 4 / SECTION 4 – 4/5 TRAY 40 X 60 – WATER/STEAM SYSTEM

FG153

BULKHEAD COUPLING
A900-34-321
(UNDER INSULATION)

COPPER PIPE
A900-34-253
(10mm OD X 20 swg)

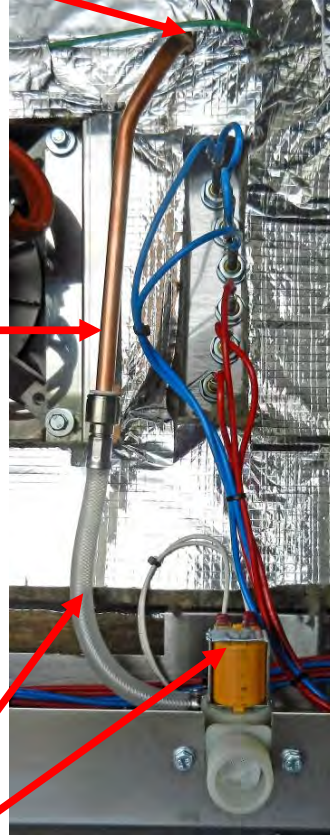

PART 12

WATER INLET ASSY (INC. HOSE)
158-17-00400

HOSE – BLUE (NOT SHOWN)
A900-34-087

PART NUMBERS REFER TO DRAWING M158E25-75200 IN ELECTRICAL MANUAL

PART 4 / SECTION 4 – 4/5 TRAY 40 X 60 – WATER/STEAM SYSTEM

FG153

EQUAL ELBOW
A900-34-387



INDIVIDUAL PART NUMBERS ARE NOT AVAILABLE FOR PIPES. ALL PIPES MADE FROM A900-34-253 COPPER PIPE 10mm O/D X 20swg WALL

PIPE GUIDE BRACKET
150-01-07700

HEATING ELEMENT
B847-04-067 = 240volts
B847-04-074 = 220volts

BULKHEAD COUPLING
A900-34-321

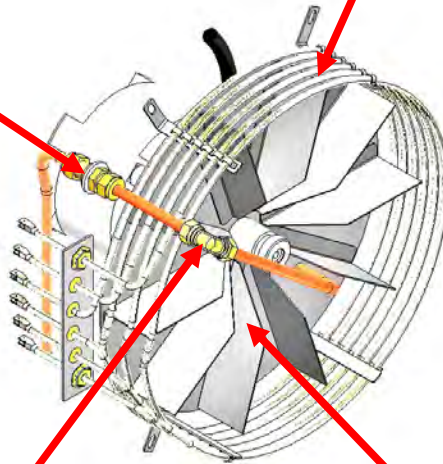

EQUAL ELBOW
A900-34-387

FAN
150-00-11000

PART 4 / SECTION 5 – 4/5 TRAY 40 X 60 BAKING CHAMBER AND DOOR PARTS

FG153

TOP HINGE LH OVEN PT No.158-03-10501

TOP HINGE RH OVEN PT No.158-03-10500

DOOR SEAL

PT No.153-23-00500

REAR SHEET

PT No.153-51-00900

FAN

PT No.158-00-11000

**OUTER/INNER
DOOR GLASS**

PT No.153-03-01700

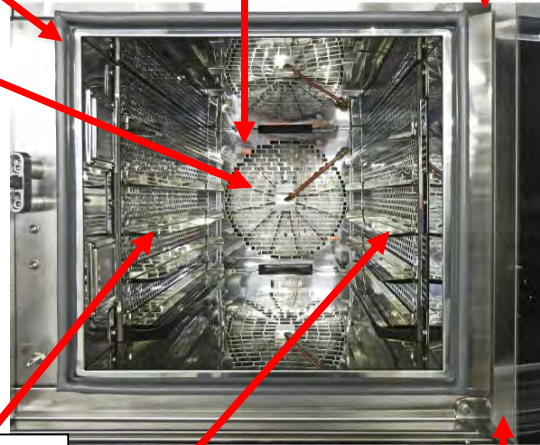

LH CLIP ON RUNNER

PT No.149-01-07101

RH CLIP ON RUNNER

PT No.149-01-07100

BOTTOM HINGE LH OVEN PT No.158-03-10500

BOTTOM HINGE RH OVEN PT No.158-03-10501

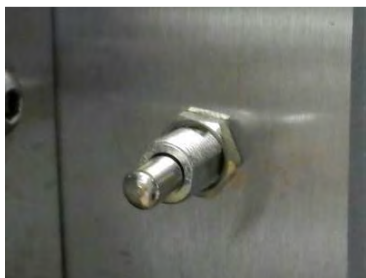

DOOR SWITCH

PT No.B842-07-023



HANDLE/ CATCH ASSEMBLY

PT No.A900-27-171

COMPLETE DOOR ASSEMBLY = PT No 153-03-01200 = LH HINGE DOOR

PT No 153-03-01201 = RH HINGE DOOR

FG153

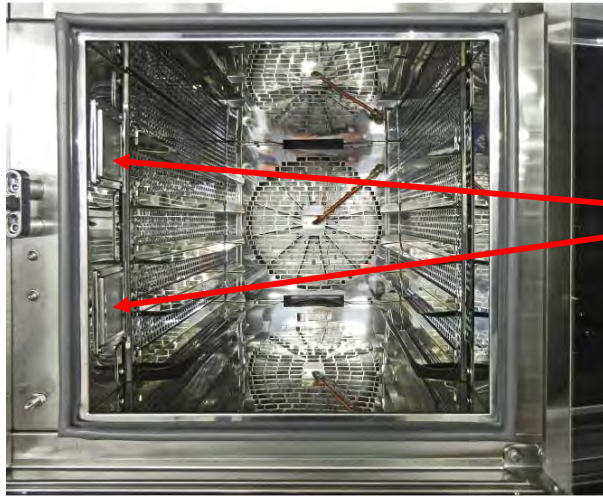

**LIGHT ASSEMBLY
PT No.B721-67-011**

INDIVIDUAL LIGHT ASSEMBLY PARTS AVAILABLE AS BELOW



REPLACEMENT BULB = B857-94-007



GASKET

Pt No.B721-67-008

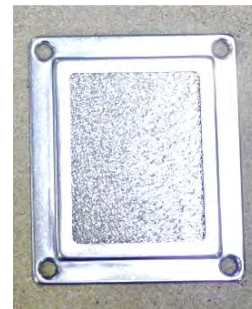

GLASS AND FRAME

Pt No.B721-67-010

Pt No.B721-67-009

DO NOT TOUCH BULBS WITH BARE HANDS.
USE A CLOTH OR GLOVES TO STOP ANY MARKS THAT WILL CAUSE HOT SPOTS AND PREMATURE BULB FAILURE.



13

CONDENSER UNIT (IF FITTED)

The condenser can be fitted to any Bx oven or stacked Bx ovens as required.

CONDENSER INFORMATION INDEX

INTRODUCTION PAGE 81

DIMENSIONS PAGE 82

SPECIFICATIONS PAGE 83

INSTALLATION PAGE 84

SAFETY PAGE 86

OPERATION PAGE 87

SPARES PAGE 88

ELECTRICAL INFORMATION
SEE ELECTRICAL MANUAL AVAILABLE SEPERATLY

INTRODUCTION

The condenser can be fitted to any Bx oven or stacked Bx ovens as required. With thermostatic control it can be adjusted to operate in most ambient temperatures. Simple water connection (washing machine type fitting) and a hose to drain are all that is required to operate efficiently.

Steam is drawn from the fluepipe of the oven through a thermostatically controlled water cooled chamber and condenses to drain away.

When the cooling water reaches a set temperature it is automatically replaced with cold water to keep the condensing process as efficient as possible.

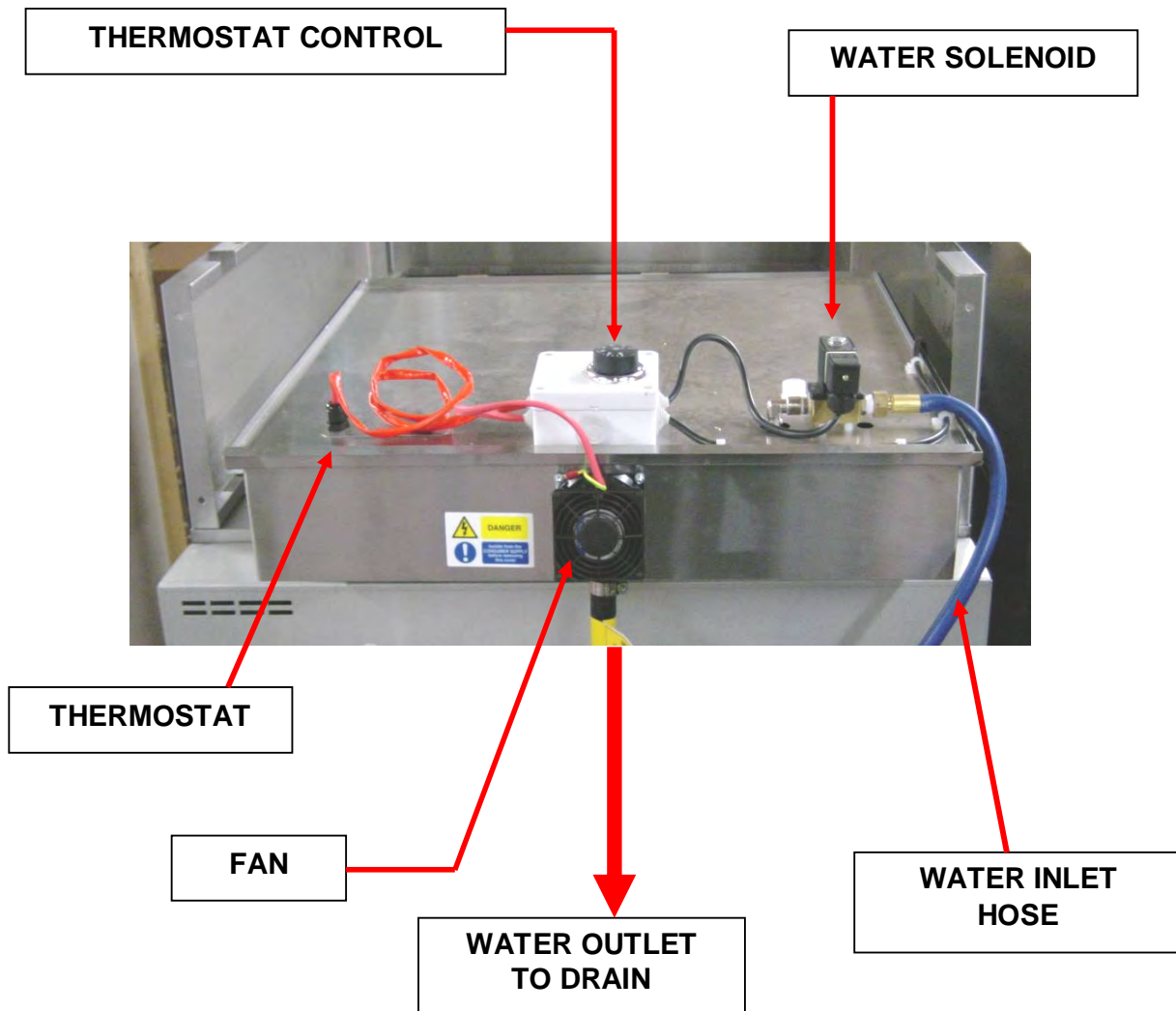

DIMENSIONS

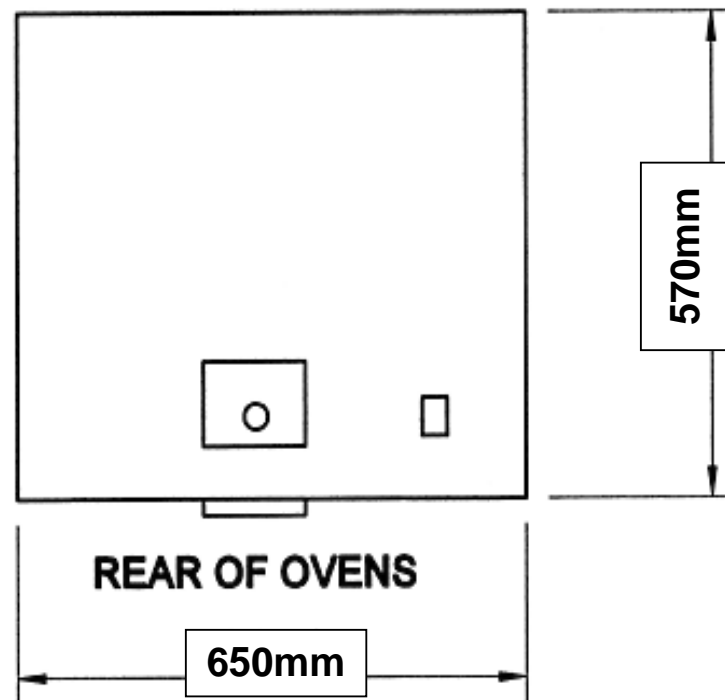
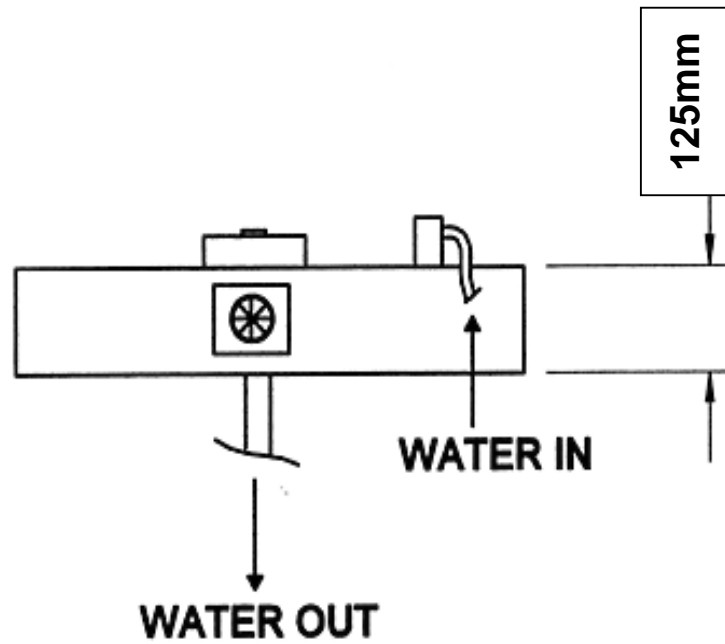

SPECIFICATIONS

POWER 230volts, 1 phase, 50hz,
21watts
Wired to oven electrical panel.

WATER Washing machine type connection to normal water supply
via steam water connection to oven(s).

NOISE Less than 85dB

WEIGHT Approx 18kg (not including water)

INSTALLATION

BEFORE INSTALLING ENSURE THAT ALL POWER IS DISCONNECTED AND THE OVEN IS COOL

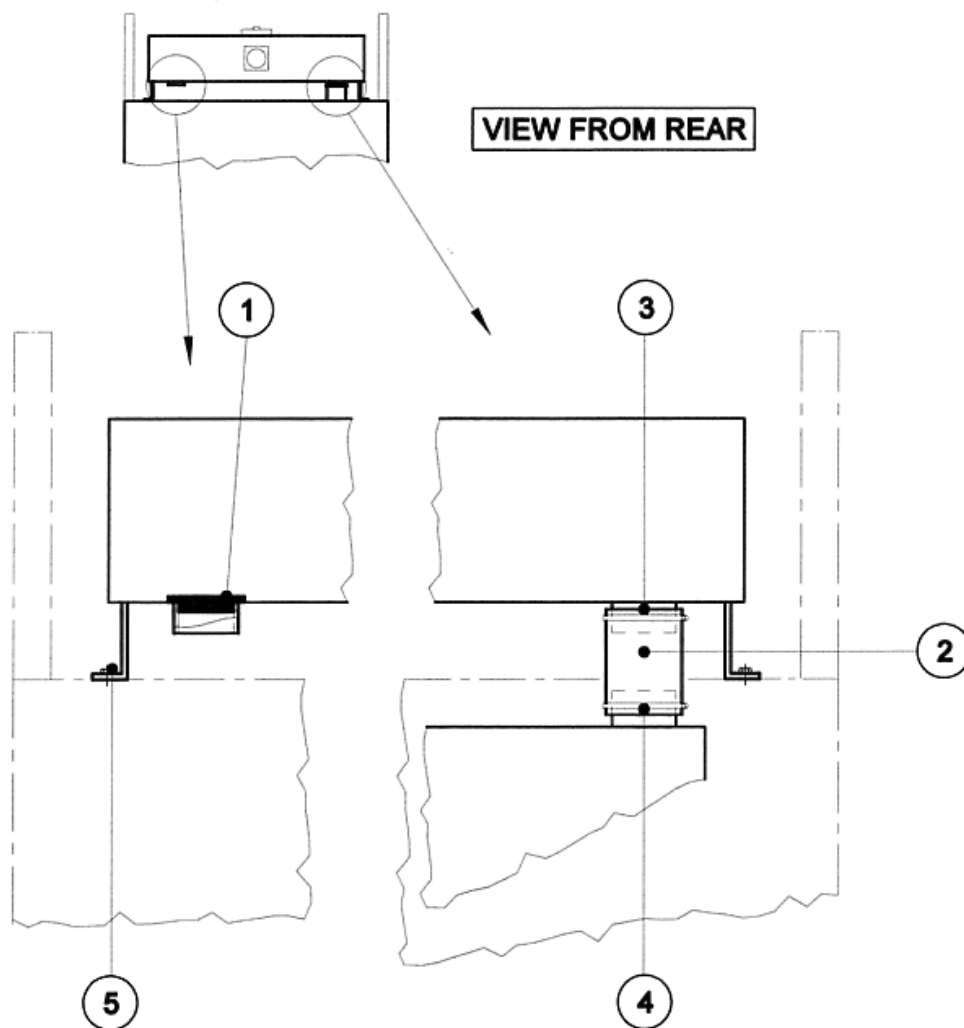

1. Before fitting the main condenser assembly, insert blanking plug **(1)** into lower hole that will not be required for the hand of oven being used.
2. Connect tube **(2)** to the spigot and retain with worm-drive clip **(3)**.

NOTE

If fixing holes are not present on the top sheet of the oven, they should be marked and drilled at this stage.

Position condenser correctly and mark hole positions (*centre of each slot*). Remove condenser and drill holes of 6.5mm diameter at 4 positions.

3. Place condenser in position ensuring that the tube (2) passes through the hole in the top of the oven and worm drive clip (4), then over spigot of the damper assembly on the oven.
4. Tighten worm-drive clip (4).
5. Fasten condenser unit to top of oven with M6 x 12mm long hex head screws and washers in 4 positions.
(If holes have been drilled, nuts will have to be used also).
6. Connect wiring, depending on whether the oven is 4 tray or 10 tray, as shown in electrical manual.
7. Connect drain hose to a suitable drain.
8. Attach water tap bracket to frame of base as shown and fasten water hose to a water supply. *(A tee pipe must be used on double ovens)*

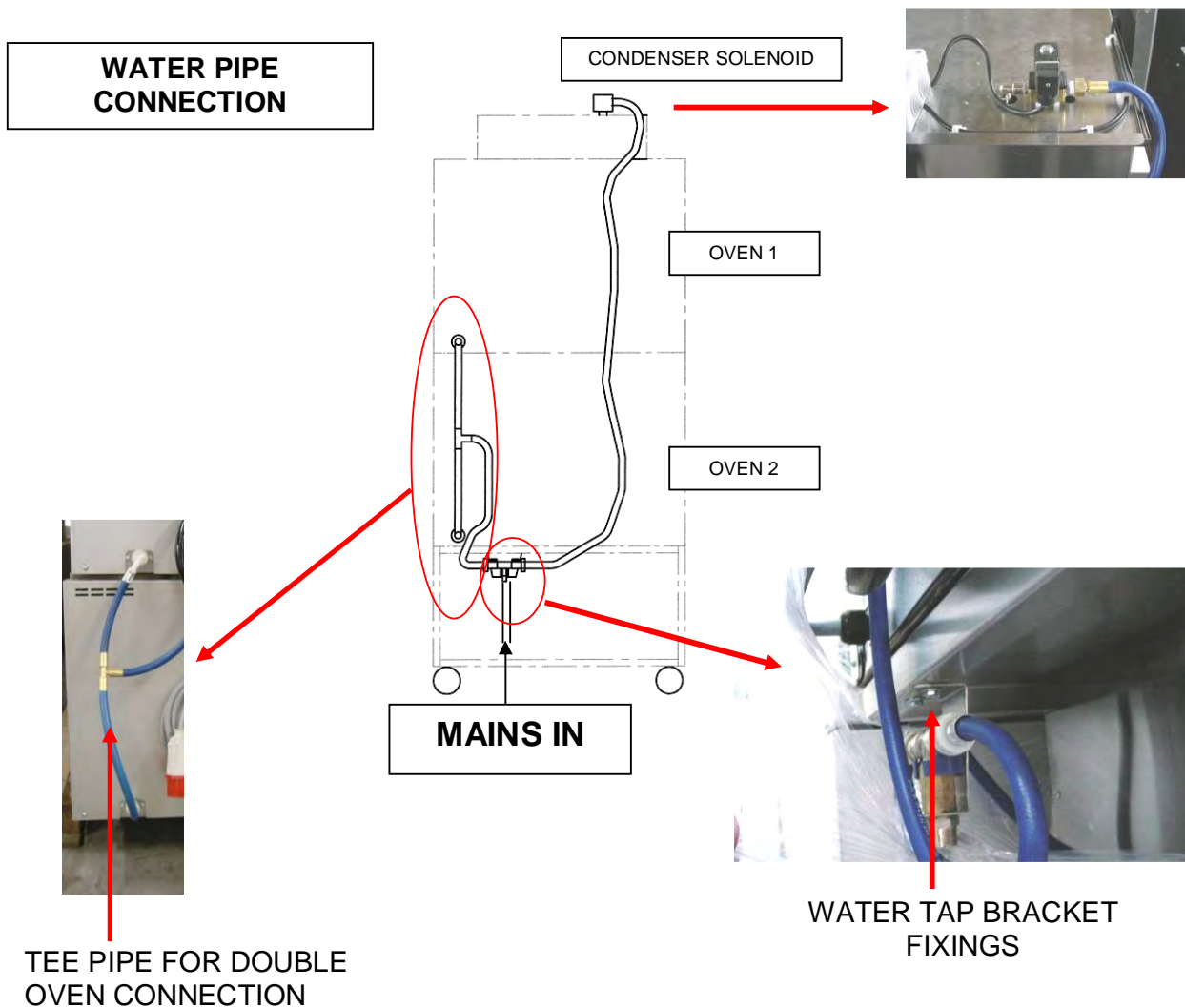

SAFETY

**BEFORE INSTALLING ENSURE THAT ALL POWER IS DISCONNECTED
AND THE OVEN(S) IS COOL**

1. All repairs and maintenance of electrical units must be carried out by authorised electricians; even then, electrical access panels must not be opened unless the mains supply to the oven is isolated.
2. All connections to the oven must be made in accordance with the statutory requirements of the country of installation.
3. While the oven is in operation (and for some time after use), **it is inadvisable to touch the condenser or the surrounds because of conducted heat.**
4. The condenser must be operated as described in this manual.
5. Only **MONO** spare parts should be used on this condenser.
6. The construction of the condenser must not be changed.
7. If the oven is not to be used for some time, it is advisable to ensure that the condenser unit is drained of water.

OPERATION

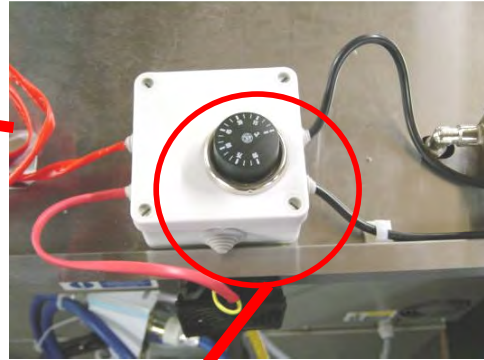
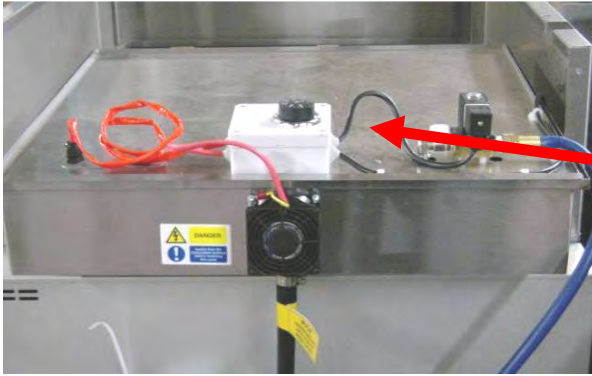

SETTING POSITION

1. Ensure that the water is connected correctly and the oven power is on.
2. The thermostat control should be adjusted to the required position.

It is suggested that as a starting point the thermostat is set at 60.

It can then be adjusted down if the performance drops or adjusted up if it is found that the water is being replaced too often.

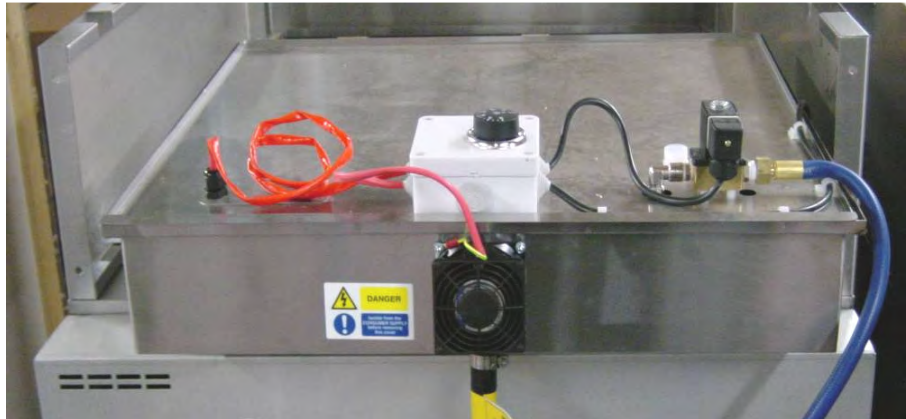

CONDENSER SPARES INFORMATION

FOR ENGINEERS USE ONLY.

DO NOT ATTEMPT ANY ALTERATIONS.
IF IN DOUBT, CONTACT MONO EQUIPMENT FOR ADVICE

MONO

Queensway
Swansea West Industrial Estate
Swansea. SA5 4EB UK

email: spares@monoequip.com

Web site: www.monoequip.com

Tel. +44(0)1792 561234

Spares +44(0)1792 564039

Fax. 01792 561016

CONDENSER UNIT MAIN PARTS

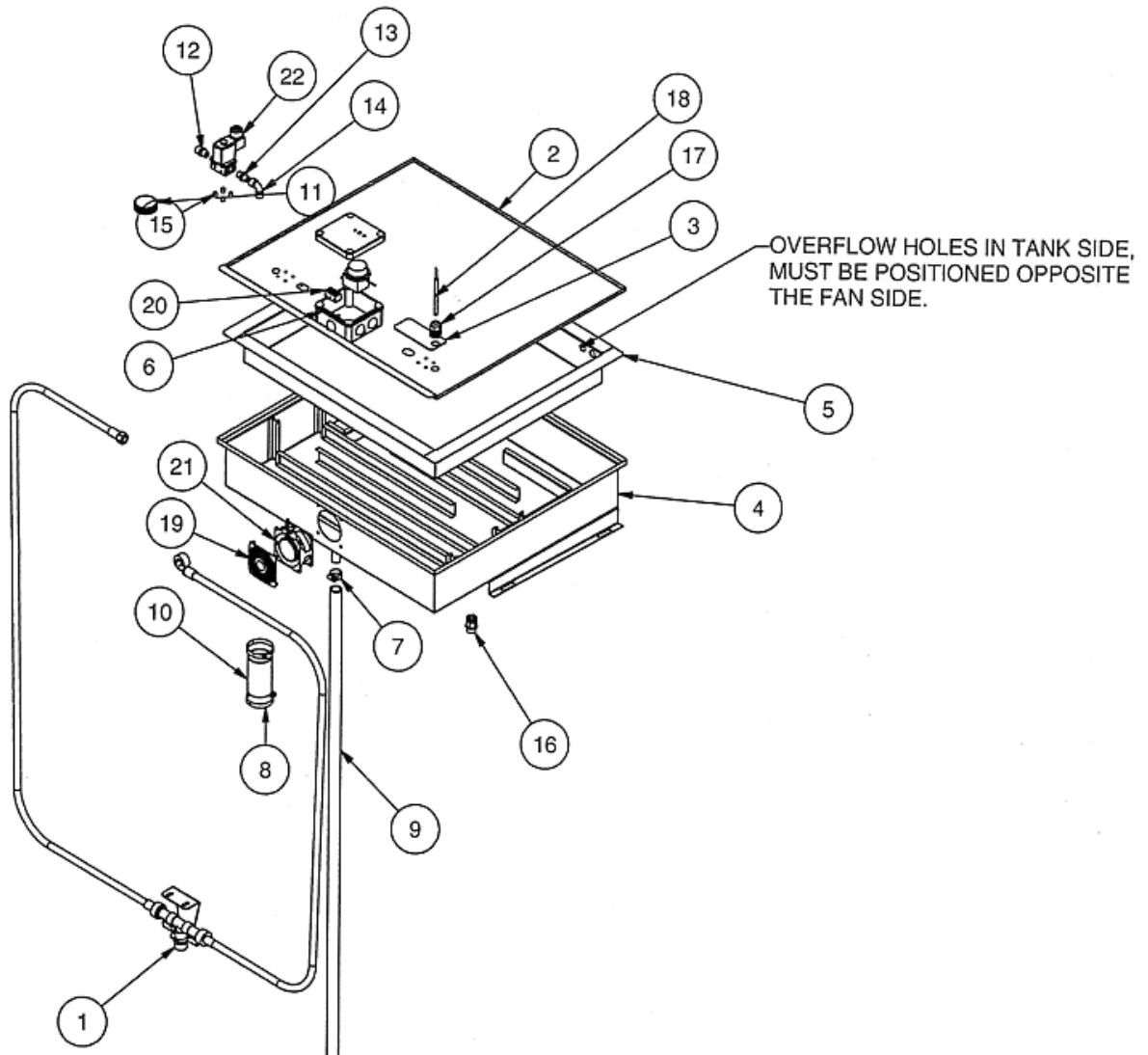

ITEM	PART No.	DESCRIPTION	QTY
①	150-07-01300	INLET WATER CONTROL UNIT	1
②	150-19-01700	TOP SHEET	1
③	150-19-02300	COVER PLATE	1
④	150-19-02600	BASE TRAY	1
⑤	150-19-02700	WATER TANK	1
⑥	150-25-07100	JUNCTION BOX	1
⑦	A900-01-196	WORM DRIVE CLIP	1
⑧	A900-01-271	WORM DRIVE CLIP	2
⑨	A900-23-004	DRAIN TUBE (2 METRES)	1
⑩	A900-23-027	FLEXIBLE TUBE	1
⑪	A900-27-187	PLUG INSERT	1
⑫	A900-34-191	REDUCER ¼" BSP MALE X 3/8" BSPT MALE	1
⑬	A900-34-244	REDUCER ¼" BSP MALE X ¼" BSPT MALE	1
⑭	A900-34-245	ELBOW	1
⑮	B811-33-001	SPACER	4
⑯	B839-17-003	CABLE GLAND TYPE 251	1
⑰	B842-17-005	CABLE GLAND TYPE 206-6096	1
⑱	B842-30-003	THERMOSTAT	1
⑲	B842-40-002	FAN GUARD	1
⑳	B842-50-005	PORCELAIN CONNECTING BLOCK	1
㉑	B869-75-003	FAN	1
㉒	B867-83-011	SOLENOID VALVE	1

If a fault arises, please do not hesitate to contact the
Customer Service Department, quoting the **machine serial number**
on the silver information plate of the machine and on the front cover of this manual



MONO

Queensway
Swansea West Industrial Estate
Swansea. SA5 4EB UK

email: spares@monoequip.com
Web site: www.monoequip.com

Tel. +44(0)1792 561234
Spares +44(0)1792 564039
Fax. 01792 561016

□ OVEN DISPOSAL

CARE SHOULD BE TAKEN WHEN THE MACHINE COMES TO THE END OF ITS WORKING LIFE.
ALL PARTS SHOULD BE DISPOSED OF IN THE APPROPRIATE PLACE, EITHER BY RECYCLING
OR OTHER MEANS OF DISPOSAL THAT COMPLIES WITH LOCAL REGULATIONS.

(IN UK, ENVIRONMENTAL PROTECTION ACT 1990 APPLIES)