

OPERATOR'S MANUAL  
TECHNICAL SUPPORT  
DEFECT REPORTS  
PARTS AND ELECTRICAL DIAGRAMS  
PLANNING  
DIAGRAMS



Part of  
Cut-N-Fry  
system  
(optional)

# Donut Fryer

## Model: 616B

### ITEM NUMBER

- |   |  |
|---|--|
| <input type="checkbox"/> <b>8848011</b> 208V/60Hz/1-Phase, Domestic | <input type="checkbox"/> <b>8848014</b> 236V/50-60Hz/1-Phase, International CE |
| <input type="checkbox"/> <b>8848012</b> 236V/60Hz/1-Phase, Domestic | <input type="checkbox"/> <b>8848015</b> 236V/50-60Hz/1-Phase, International    |

### SERIAL NUMBER

Item Number and Serial Number are listed on a data tag attached to the equipment.  
This manual should only be used with the Item Number(s) shown above.



DECLARATION  
OF CONFORMITY  
INSIDE





*Belshaw*<sup>®</sup>

# Counter Top Fryer

# 616B

## Operator's Manual

Belshaw Adamatic Bakery Group  
814 44<sup>th</sup> Street NW, Suite 103  
Auburn, WA 98001 USA  
Phone: 800-578-25474 • (+1) 253-886-5340  
service@belshaw.com • www.belshaw.com

## EQUIPMENT RECORD

Please provide the information below when you correspond with Belshaw about your machine.

Purchased by \_\_\_\_\_

Installed by \_\_\_\_\_

Date of Installation \_\_\_\_\_

Model: 616B Countertop Fryer \_\_\_\_\_

Serial number \_\_\_\_\_

## IN CASE OF DAMAGE TO EQUIPMENT

In case of damage to the equipment upon delivery, follow these steps immediately.

1. Inform the freight carrier. The phone number will be on the shipping receipt or label.
2. Take photographs of the equipment, both inside and outside the box or crate.
3. Do not throw away any packaging.
4. Report the damage to the distributor (or other party) from whom you bought the equipment.
5. Email your photos to the distributor (or other party) AND to Belshaw Customer Service at [service@belshaw.com](mailto:service@belshaw.com). Include a Belshaw Order Number in your communications. Your Order Number will begin with "CO...", followed by 6 digits) and should be marked on the box or crate.

## IN CASE OF MISSING ITEMS

1. If possible, note the missing items on the delivery receipt of the freight carrier.
2. Take photographs of the entire shipment.
3. Follow steps 2 – 5 above.

021017

MN-1137EN

Belshaw Adamatic Bakery Group

814 44<sup>th</sup> Street Northwest, Suite 103

Auburn, WA 98001 USA

Phone: (206) 322-5474 • Fax: (206) 322-5425

E-mail: [service@belshaw.com](mailto:service@belshaw.com) • <http://www.belshaw-adamatic.com>

# Contents

## Sections

<b>1</b>	<b><i>Operation</i></b>	<b>5</b>
	Frying Tips	6
<b>2</b>	<b><i>Cleaning</i></b>	<b>7</b>
	Cleaning the Exterior Surfaces	7
	Cleaning the Frying Screen	7
	Cleaning the Kettle	7
<b>3</b>	<b><i>Donut-Making Helps</i></b>	<b>9</b>
	Tips on Making Quality Cake Donuts	9
	Calculating Correct Water Temperature	10
	Ratios of Plunger Sizes to Donut Weights	10
	Temperature Conversion	10

# Preface

The 616B and 616BT donut fryers have been designed and built using the finest materials and components available. It is the result of years of research and development. Designed into this unit are many features which will insure more quality in your products and reduce your operating cost. Attention to the instructions regarding installation, operation, and maintenance should result in years of trouble-free service.

The operator must work safely at all times and read this manual and follow its instructions and warnings. A thorough understanding of how to install, maintain, and safely operate the fryer will prevent production delays and injuries.

Heed the following warnings and all other warnings that appear in this manual:

- To avoid damaging the machine, never use force to assemble, disassemble, operate, clean, or maintain it.
- Never let water and hot shortening come in contact with each other. Moisture causes hot shortening to spatter, which may cause serious burns.
- Do not overfill the kettle with shortening. If shortening overflows the kettle, it could cause serious burns or could cause someone to slip on the floor and be seriously injured.
- Hot shortening can cause serious burns. Make sure that the system and the shortening are cool before attempting any cleaning, adjustment, disassembly, or repair.
- To avoid electrocution or other injury, unplug the machine before attempting any cleaning, adjustment, disassembly, or repair.
- Be careful never to get shortening, water, or other materials on the floor. If anything does get spilled on the floor, mop it up immediately. Materials on the floor can cause people to slip or fall, resulting in serious injury or loss of life.
- To prevent unintentional startup and possible fire, unplug the machine if there is a local power outage. When the power is restored, it is safe to plug the machine in again.
- To avoid electrocution, make sure that all electrical cords are not frayed or cracked and that they do not pass through any water or shortening.
- Make sure that all electrical cords are routed so that no one will trip over them.

# 1

# Operation

**Read** each step **completely** before doing what it tells you to do.

1. Put enough shortening in the kettle to completely cover the heating elements, thermocouple, and high-temperature limit control probe.

Put shortening in the kettle using one of these methods:

## WARNING

**Hot shortening causes severe burns.**

- Melt shortening in a pan on the stove and pour it into the kettle.
- Put solid shortening into the kettle, packing it tightly around the heating elements, thermocouple, and high-temperature limit control probe.

## WARNING

**Air spaces can cause the shortening to overheat and catch on fire.**

2. Turn on the unit by turning the thermostat clockwise 1/16 turn. When the unit is turned on, the power light located next to the thermostat knob will be lit.
3. Set the thermostat to 250°F/121°C. The “Heating” pilot light above the elements will light up, indicating that the shortening has not yet reached the selected temperature.
4. Continue adding shortening to the kettle until it reaches the “Oil Level” marks on the kettle. Use one of the following methods.

- Melt shortening in a pan on the stove and pour it into the kettle.
- Very carefully put solid shortening into the kettle.

## WARNING

**To avoid serious burns, be very careful not to splatter hot shortening when you add shortening to the kettle.**

Because shortening expands as it increases in temperature, put shortening in the kettle gradually. Let the shortening in the kettle heat up before you add more.

5. After all of the shortening has melted, set the thermostat to the desired frying temperature.

The “Heating” pilot light will go out if the high temperature limit control breaks the circuit.

Note: If the high temperature limit control does break the circuit, push the red reset button on the back of the heater head.

6. Wait for the shortening to reach the desired temperature.

## WARNING

**To avoid serious burns, when the fryer is operating, do not touch any part of the fryer that is in contact with hot shortening.**

7. If you are frying cake or French donuts, move the cutter into place over the fryer. Refer to the cutter manual (Type N cutter)

for complete installation and operation instructions.

To fry yeast-raised donuts, place donuts on the fry screen and slowly lower the screen into the fryer. With the donut stick, turn the donuts over to fry the top side. Remove the fry screen and donuts when the donuts are completely fried by lifting up the fry screen with the donuts on top of it. Immediately place on or over a tray to catch dripping shortening.

### **WARNING**

**Hot shortening will drip off the fry screens, causing a slip hazard. To avoid serious injury or loss of life, be very careful and immediately clean up any drips.**

### **WARNING**

**To avoid serious burns, be careful of hot shortening dripping from the fry screens. Do not touch hot shortening and immediately clean up spills and drips.**

## **Frying Tips**

1. Use a high quality hydrogenated shortening.
  2. Store your supply of cooking shortening at room temperature.
  3. To prolong the life of the shortening, do not keep shortening at high temperature if the fryer is not being used.
  4. Drain and strain shortening periodically. Several layers of cheesecloth will do a good job of filtering.
  5. Keep the fryer and screens clean.
  6. Maintain shortening at the proper level in the fryer. Add fresh shortening to keep the level at the “Oil Level” marks stamped on the kettle sides.
  7. Add at least 15% fresh shortening to your kettle daily.
  8. Discard shortening as soon as it tends to bubble or foam during frying.
  9. At least once a day, cool a small sample of shortening from the fryer and taste it to see if it has picked up a foreign or rancid taste.
8. Continue supplying shortening to the kettle as required. Keep the kettle filled up to the “Oil Level” marks on the side.
  9. When you are done frying donuts, move the thermostat knob counter-clockwise as far as it will go.

For your safety, observe the following warnings throughout the entire cleaning process.

### WARNING

**Thoroughly clean and dry the floor if shortening, water, or other materials are spilled. Materials spilled on the floor can cause serious injury or loss of life.**

### WARNING

**To avoid electrocuting yourself or damaging the machine, never allow water, steam, shortening, cleaning solution, or any other liquid to enter the electrical box or the heater head.**

### WARNING

**To avoid being burned in an explosion, never use any flammable materials for cleaning.**

## Cleaning the Exterior Surfaces

1. Clean the polished and painted surfaces of the fryer with a soft, damp cloth. Use a non-abrasive cleaner to remove any discoloration.
2. Polish these surfaces with a soft, dry cloth.

## Cleaning the Frying Screen

1. In a sink or a dishwasher, wash the frying screen using warm water and mild detergent. Do not use an abrasive cleaner or scraper.
2. Rinse the frying screen in clear water.
3. Dry the frying screen thoroughly, using a soft cloth, before you use it again.

### WARNING

**Dry the frying screen thoroughly. Moisture causes hot shortening to spatter, which may cause serious injury.**

4. Check the frying screen to make sure no metal is flaking off of it. If the screen is flaking, replace it immediately, so you do not get metal particles in your product.

## Cleaning the Kettle

### Removing the Shortening

### WARNING

**To avoid being burned or electrocuted, disconnect the fryer from the power source before cleaning it.**

1. Disconnect the machine from the power source.
2. Let the shortening cool to 100°F/38°C.
3. Carefully dip out the shortening into a suitable container. Do not disturb the accumulated sediment in the bottom of the kettle.

---

**WARNING**

**Do not use a plastic container. If the shortening is not cool enough, the container will melt, possibly causing you to be burned, and causing shortening spill.**

**WARNING**

**Do not allow the shortening to overflow the containers. Shortening will get on the floor, and if the shortening is not cool enough, you may be burned.**

4. After the kettle has been drained, brush any accumulated carbon from the heater coils. Accumulated carbon causes corrosion and poor heat recovery.
5. Remove the drain tray.

**WARNING**

**Thoroughly clean and dry the floor if shortening is spilled. Shortening on the floor can cause serious injury or loss of life.**

6. Remove the heater head and element.
7. Lift out the kettle and pour out the remaining shortening and accumulated sediment.
8. Flush out the kettle with hot water to remove all sediment.

**Washing**

1. Wash the kettle carefully with detergent to remove all stains and burned shortening.
2. Scrub the inside of the kettle. Do not use any abrasive cleaners or scrapers.

**WARNING**

**To avoid being burned, be very careful as you work with hot cleaning solution. Never put your hands in the solution. Wear gloves and long sleeves in case any solution splashes.**

3. Dry the kettle thoroughly with a soft cloth before replacing in the fryer cabinet.

**WARNING**

**Dry the kettle thoroughly. Moisture causes hot shortening to spatter or erupt. Shortening may spatter or overflow the sides of the fryer may result in fire, serious injury, or death.**

4. Make sure the kettle is properly seated in the case.
5. Install the heater head.

# 3

# Donut-Making Helps

## Tips on Making Quality Cake Donuts

- Use the correct batter temperature.

In general, the correct batter temperature is 75°-80°F/24°-27°C. Check the mix manufacturer's instructions, as the recommended temperature range may vary.

If the batter is too warm, the donuts will lack volume and may "ring out" or be misshapen. If the batter is too cold, the donuts will stay under the shortening too long, fry too slowly, and crack open or ball up. They may also absorb excess shortening and lose volume.

- Use the correct floor time.

A floor time of 10 minutes between mixing and cutting allows the baking powder to react with the water. This helps the donuts attain the proper volume the proper level of shortening penetration.

If the floor time exceeds 30 minutes, the mix will gas off, the donuts will lose volume and shape and will absorb too much shortening.

- Use the correct frying temperature.

The correct shortening temperature for frying is 370°-380°F/188°-193°C.

If the shortening is too hot, the donuts will fry too quickly on the outside and will lose volume. The donuts may also become dense inside.

If the shortening is too cold, the donuts will spread too rapidly, will form large rings, will tend to crack open, will be too light in appearance, and will absorb too much shortening.

- Maintain the proper shortening level. We recommend a distance of 1 1/4" between the cutter and the shortening.

If the shortening is too deep, the donuts may not turn over when they reach the turner, causing them to cook unevenly.

If the shortening is too shallow (too far below the cutter), the donuts may not drop flat, may turn over while submerging and surfacing, and may become irregular, cracked, or rough-cruled.

- Ensure that the donuts absorb the right amount of shortening.

Donuts should absorb 1-1/2 to 3 oz/42 to 85 g of shortening per dozen, depending on their weight. You can achieve proper absorption by following tips 1-3.

- If the donuts do not absorb enough shortening, they will not keep well.

If they absorb too much shortening, they will lose volume and may become misshapen. If this happens, follow tips 1-3, mix the batter a little longer than usual, turn the donuts as soon as they become golden brown, and turn the donuts only once.

## Calculating Correct Water Temperature

The following is an example of how to calculate the correct water temperature to use. You must

use your own room temperature, dry mix temperature, desired batter temperature, and, if you are making yeast-raised donuts, estimated temperature increase during mixing.

	<b>Cake Donuts</b>		<b>Yeast-Raised Donuts</b>	
	°F	°C	°F	°C
Room temperature	72	22.2	72	22.2
Dry mix temperature	<u>+70</u>	<u>+21.1</u>	<u>+70</u>	<u>+21.1</u>
<b>Total A</b>	142	43.3	142	43.3
Desired batter temperature	75	23.9	80	26.7
	<u>x3</u>	<u>x3</u>	<u>x3</u>	<u>x3</u>
<b>Total B</b>	225	71.7	240	80.1
<b>Total B</b>	225	71.7	240	80.1
<b>-Total A</b>	<u>-142</u>	<u>-43.3</u>	<u>-142</u>	<u>-43.3</u>
Desired water temp. for cake donuts	<b>83°F</b>	<b>28.4°C</b>	98	36.8
			↓	↓
			Figure from above	
			98	36.8
Temperature increase during mixing (average: 30°F/17°C)			<u>-30</u>	<u>-17</u>
Desired water temperature for yeast-raised donuts			<b>68°F</b>	<b>19.8°C</b>

## Ratios of Plunger Sizes to Donut Weights

The weights given are for donuts without icings or other toppings. They are provided for reference only, as weights vary according to the density of the batter.

<b>Plunger Size</b>	<b>Donut Weight per Dozen</b>
1"	5-8 oz/142-227 g
1 7/16"	10-17 oz/283-482 g
1 9/16"	14-21 oz/397-595 g
1 13/16"	19-23 oz/539-652 g

## Temperature Conversion

To convert temperatures from Fahrenheit to Celsius, subtract 32 from °F and divide the result by 1.8. For example,  $212^{\circ}\text{F} - 32 / 1.8 = 100^{\circ}\text{C}$ .

To convert temperatures from Celsius to Fahrenheit, multiply °C by 1.8 and add 32 to the result. For example,  $(100^{\circ}\text{C} \times 1.8) + 32 = 212^{\circ}\text{F}$ .

°F	°C	°F	°C
55	12.8	340	171.1
60	15.6	345	173.9
65	18.3	350	176.7
70	21.2	355	179.4
75	23.9	360	182.2
80	26.7	365	185.0
325	162.8	370	187.8
330	165.6	375	190.6
335	168.3	380	193.3



*Belshaw*<sup>®</sup>

# Counter Top Fryer

# 616B

## Technical Supplement

Belshaw Adamatic Bakery Group

814 44<sup>th</sup> Street NW, Suite 103

Auburn, WA 98001 USA

Phone: 800-578-25474 • (+1) 253-886-5340

service@belshaw.com • www.belshaw.com

## EQUIPMENT RECORD

Please provide the information below when you correspond with Belshaw about your machine.

Purchased by \_\_\_\_\_

Installed by \_\_\_\_\_

Date of Installation \_\_\_\_\_

Model number \_\_\_\_\_

Serial number \_\_\_\_\_

## IN CASE OF DAMAGE TO EQUIPMENT

In case of damage to the equipment upon delivery, follow these steps immediately.

1. Inform the freight carrier. The phone number will be on the shipping receipt or label.
2. Take photographs of the equipment, both inside and outside the box or crate.
3. Do not throw away any packaging.
4. Report the damage to the distributor (or other party) from whom you bought the equipment.
5. Email your photos to the distributor (or other party) AND to Belshaw Customer Service at [service@belshaw.com](mailto:service@belshaw.com). Include a Belshaw Order Number in your communications. Your Order Number will begin with "CO...", followed by 6 digits) and should be marked on the box or crate.

## IN CASE OF MISSING ITEMS

1. If possible, note the missing items on the delivery receipt of the freight carrier.
2. Take photographs of the entire shipment.
3. Follow steps 2 – 5 above.

021017

MN-1138EN

Belshaw Adamatic Bakery Group  
814 44<sup>th</sup> Street Northwest, Suite 103  
Auburn, WA 98001 USA

Phone: (206) 322-5474 • Fax: (206) 322-5425

E-mail: [service@belshaw.com](mailto:service@belshaw.com) • <http://www.belshaw-adamatic.com>

# Contents

## Sections

<b>1</b>	<b><i>Installation</i></b>	<b>5</b>
	Unpacking the Fryer	5
	Initial Cleaning	5
	Installing the Fryer	5
	Moving the Fryer	6
<b>2</b>	<b><i>Cleaning</i></b>	<b>7</b>
	Cleaning the Exterior Surfaces	7
	Cleaning the Frying Screen	7
	Cleaning the Kettle	7
<b>3</b>	<b><i>Calibrating The Fryer</i></b>	<b>9</b>
	Calibration of <a href="#">618-0006</a> Temperature Indicator	9
<b>4</b>	<b><i>Cut-N-Fry Installation with Type N Depositor (Optional)</i></b>	<b>10</b>
	Mounting Instructions	10
<b>5</b>	<b><i>Parts Lists and Diagrams</i></b>	<b>12</b>

# Preface

The 616B and 616BT donut fryers have been designed and built using the finest materials and components available. It is the result of years of research and development. Designed into this unit are many features which will insure more quality in your products and reduce your operating cost. Attention to the instructions regarding installation, operation, and maintenance should result in years of trouble-free service.

The operator must work safely at all times and read this manual and follow its instructions and warnings. A thorough understanding of how to install, maintain, and safely operate the fryer will prevent production delays and injuries.

Heed the following warnings and all other warnings that appear in this manual:

- To avoid damaging the machine, never use force to assemble, disassemble, operate, clean, or maintain it.
- Never let water and hot shortening come in contact with each other. Moisture causes hot shortening to spatter, which may cause serious burns.
- Do not overfill the kettle with shortening. If shortening overflows the kettle, it could cause serious burns or could cause someone to slip on the floor and be seriously injured.
- Hot shortening can cause serious burns. Make sure that the system and the shortening are cool before attempting any cleaning, adjustment, disassembly, or repair.
- To avoid electrocution or other injury, unplug the machine before attempting any cleaning, adjustment, disassembly, or repair.
- Be careful never to get shortening, water, or other materials on the floor. If anything does get spilled on the floor, mop it up immediately. Materials on the floor can cause people to slip or fall, resulting in serious injury or loss of life.
- To prevent unintentional startup and possible fire, unplug the machine if there is a local power outage. When the power is restored, it is safe to plug the machine in again.
- To avoid electrocution, make sure that all electrical cords are not frayed or cracked and that they do not pass through any water or shortening.
- Make sure that all electrical cords are routed so that no one will trip over them.

# 1

# Installation

## Unpacking the Fryer

1. Use a fork lift to transport the shipping crate to the work station.
2. Break down the shipping crate.
3. Remove all the packing materials from the fryer. These include foam, tape, brown paper, plastic, and white protective coating.
4. Check the fryer carefully for any damage that may have occurred during shipping. File any claims with the shipping company.
5. Position the fryer to allow sufficient space on either end of the machine for any equipment you plan to use with it.

## Initial Cleaning

Clean your fryer before using it. Wipe the inside of the kettle with a soft, damp cloth. Dry the kettle thoroughly.

### **WARNING**

**To avoid electrocuting yourself or damaging the machine, never allow water, steam, cleaning solution, or other liquid to enter the heater head or the electrical box.**

### **WARNING**

**Never let water and hot shortening come in contact with each other. Moisture causes hot shortening to spatter, which may cause serious injury. Prior to use, make sure the kettle and any other parts you have washed are dry.**

## Installing the Fryer

1. Make sure the power requirements of the machine, found on the data/name plate, match your power source.
2. Set the fryer cabinet on a flat, dry counter or table.
3. Level the fryer.
4. Connect the fryer to a properly grounded power source. Do not turn on the power.
5. When first filling the kettle with shortening, if a hydrogenated or semi-solid shortening is used, melt some shortening and pour it into the kettle.
6. Cover the elements, thermostat bulb and high temperature limit control bulb with shortening before turning on the power.

### **WARNING**

**Do not turn the thermostat above 250°F until all the shortening has melted.**

7. Due to the delicate mechanism of the thermostat, it is possible for it to get out of adjustment. If this occurs, recalibrate per the instructions in section 4.

- 
8. The heater head assembly is equipped with a high temperature limit control. Push the reset button on the back of the heater head if power to the heater elements is cut off.
  9. When heating shortening that has solidified, a pocket of shortening may overheat and cause the high temperature limit control to cut power to the elements. Push the reset button to resume heating.
  6. Level the fryer and connect it to the power source, as explained in “Installing the Fryer” above.

## **Moving the Fryer**

If you ever want to move the fryer to a different workstation, follow this procedure:

1. Turn off the fryer and disconnect it from the power source.
2. Allow the machine and the shortening to cool.

<b>WARNING</b>
<b>Do not touch hot shortening. It can cause serious burns.</b>

3. Remove the shortening from the fryer as explained in “Removing the Shortening” in the Operator's Manual.

<b>WARNING</b>
<b>To avoid burns, falls, other injury, or death, never attempt to move the fryer when it has shortening or other liquid in it.</b>

<b>WARNING</b>
<b>Thoroughly clean and dry the floor if shortening is spilled. Materials on the floor can cause people to slip or fall, resulting in serious injury or loss of life.</b>

For your safety, observe the following warnings throughout the entire cleaning process.

### WARNING

**Thoroughly clean and dry the floor if shortening, water, or other materials are spilled. Materials spilled on the floor can cause serious injury or loss of life.**

### WARNING

**To avoid electrocuting yourself or damaging the machine, never allow water, steam, shortening, cleaning solution, or any other liquid to enter the electrical box or the heater head.**

### WARNING

**To avoid being burned in an explosion, never use any flammable materials for cleaning.**

## Cleaning the Exterior Surfaces

1. Clean the polished and painted surfaces of the fryer with a soft, damp cloth. Use a non-abrasive cleaner to remove any discoloration.
2. Polish these surfaces with a soft, dry cloth.

## Cleaning the Frying Screen

1. In a sink or a dishwasher, wash the frying screen using warm water and mild detergent. Do not use an abrasive cleaner or scraper.
2. Rinse the frying screen in clear water.
3. Dry the frying screen thoroughly, using a soft cloth, before you use it again.

### WARNING

**Dry the frying screen thoroughly. Moisture causes hot shortening to spatter, which may cause serious injury.**

4. Check the frying screen to make sure no metal is flaking off of it. If the screen is flaking, replace it immediately, so you do not get metal particles in your product.

## Cleaning the Kettle

### Removing the Shortening

### WARNING

**To avoid being burned or electrocuted, disconnect the fryer from the power source before cleaning it.**

1. Disconnect the machine from the power source.
2. Let the shortening cool to 100°F/38°C.
3. Carefully dip out the shortening into a suitable container. Do not disturb the accumulated sediment in the bottom of the kettle.

---

**WARNING**

**Do not use a plastic container. If the shortening is not cool enough, the container will melt, possibly causing you to be burned, and causing shortening spill.**

**WARNING**

**Do not allow the shortening to overflow the containers. Shortening will get on the floor, and if the shortening is not cool enough, you may be burned.**

4. After the kettle has been drained, brush any accumulated carbon from the heater coils. Accumulated carbon causes corrosion and poor heat recovery.
5. Remove the drain tray.

**WARNING**

**Thoroughly clean and dry the floor if shortening is spilled. Shortening on the floor can cause serious injury or loss of life.**

6. Remove the heater head and element.
7. Lift out the kettle and pour out the remaining shortening and accumulated sediment.
8. Flush out the kettle with hot water to remove all sediment.

**Washing**

1. Wash the kettle carefully with detergent to remove all stains and burned shortening.
2. Scrub the inside of the kettle. Do not use any abrasive cleaners or scrapers.

**WARNING**

**To avoid being burned, be very careful as you work with hot cleaning solution. Never put your hands in the solution. Wear gloves and long sleeves in case any solution splashes.**

3. Dry the kettle thoroughly with a soft cloth before replacing in the fryer cabinet.

**WARNING**

**Dry the kettle thoroughly. Moisture causes hot shortening to spatter, which may cause serious injury.**

4. Make sure the kettle is properly seated in the case.
5. Install the heater head.

# 3

# Calibrating The Fryer

## **Calibration of 618-0006 Temperature Indicator**

### **To check calibration, use the following steps.**

1. Turn the dial of the thermostat to a medium temperature setting of approximately 350° F.
2. Allow enough time for the temperature to stabilize and the thermostat to cycle ON and OFF.
3. Use a potentiometer or a good grade of thermometer to determine temperature.

### **To Recalibrate:**

1. Remove the ring (A) and glass crystal.
2. Insert a screwdriver in slot B, and while holding the slotted stem in position, move the temperature indicating needle (C) to the correct setting with your finger.
3. Check the temperature of the frying area again and check this against the indicator temperature reading.
4. Re-install the ring (A) and glass crystal.

## **Calibrating the Thermostat**

Each thermostat is adjusted at the factory and calibrated on precision instruments to control temperatures accurately. Adjustment or recalibration is not needed unless the thermostat has been mishandled in transit or changed or abused while in service.

### **To check calibration:**

1. Important: Make sure that the fryer is filled with shortening. Read the warnings on the control panel about high temperatures.
2. Use a good thermometer that reads temperatures up to 400°F/204°C. Place the thermometer in the shortening.
3. Set the fryer temperature to 375°F/190°C. Allow enough time for the temperature to stabilize.
4. During a 10 minute test period, the temperature should not fall below 365°F/185°C, or exceed 385°F/196°C.

### **To Recalibrate:**

1. Remove temperature dial from shaft B by pulling upward.
2. Using a small screwdriver, turn screw A as follows:
  - Counter clockwise to increase temperature
  - Clockwise to decrease temperature
3. Replace the control dial on the dial shaft
4. Recheck the calibration and continue adjusting as necessary.

# 4 Cut-N-Fry Installation with Type N Depositor (Optional)

This section shows how to mount a Type N depositor with your 616B fryer to form a Cut-N-Fry combination.

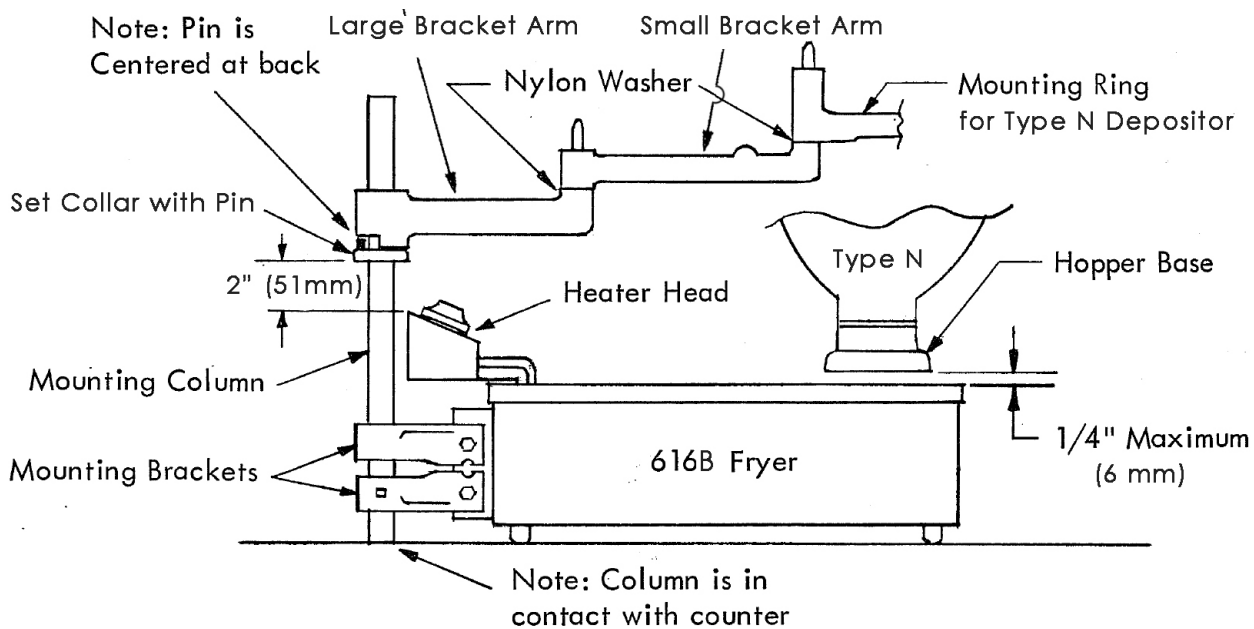

## SAFETY NOTICE

The cut-n-fry unit should be located on a solidly constructed countertop with the heater head toward the wall. When the unit is not mounted near the wall and is accessible from all sides, the 616B fryer should be bolted to the table (or other surface that supports it). A hole can be drilled through the bottom of the outer case, after removing the kettle.

## Mounting Instructions

1. Mount the **Mounting Brackets** at the rear of the 616B FRYER.
  - Fasten securely to the metal block using the included 1/4 inch bolts.
2. Place the **616B Fryer** in the position where it will be used, and slide the **Mounting Column** into place.
  - The column should rest on the counter top surface. Tighten the set screws in the mounting brackets.

3. Place the **Set Collar with Pin** onto the column as shown, approximately 2 inches (51mm) above the **Heater Head** of the fryer.
  - The pin should point upward. Tighten the set screw securely. Oil the column above the set collar with light machine oil.
4. Slide the **Large Bracket Arm** onto the **Mounting Column** until it rests on the **Set Collar With Pin**.
  - Oil the pin slightly and install the **Nylon Washer**.
5. Place the **Small Bracket Arm** onto the pin of the Large Bracket Arm.
  - Oil the pin slightly and install the **Nylon Washer**.
6. The **Hopper Base** of the Type N Depositor will be mounted on the pin of the **Small Bracket Arm**.
  - The bottom of the depositor should be 1/4" (6 mm) above the rim of the **616B Fryer**.



# 5

# Parts and Electrical Diagrams

Mechanical and electrical diagrams for 616B Fryers with Item Numbers 8848011, 8848012, 8848014, 8848015 are indicated in the table below.

### ABOUT ITEM NUMBERS:

All machines are identified by an Item Number. The Item Number is located on a data tag attached to machine.

You need to know your fryer's Item Number to identify parts diagrams for that fryer.

When you have found your Item Number, mark it on the front cover of this manual, and also immediately below.

### RECORD YOUR ITEM NUMBER AT LEFT BELOW:

MARK FOR YOUR FRYER	ITEM NUMBER	MODEL	VOLTS	HERTZ	PHASE	TYPE
<input type="checkbox"/>	<b>8848011</b>	616B	120V	50/60 hz	1	DOMESTIC
<input type="checkbox"/>	<b>8848012</b>	616B	236V	50/60 hz	1	DOMESTIC
<input type="checkbox"/>	<b>8848014</b>	616B	236V	50/60 hz	1	INTERNATIONAL (CE)
<input type="checkbox"/>	<b>8848015</b>	616B	236V	50/60 hz	1	INTERNATIONAL

For Item Numbers not listed, contact Belshaw Service at [service@belshaw.com](mailto:service@belshaw.com).

### RECORD YOUR SERIAL NUMBER HERE:

DIAGRAM: 616B-1500, 616B-1501, 616B-1502 COMBINED

USE THIS DIAGRAM FOR

**MODEL: 616B**

**ITEM NUMBER:**

**8848011, 8848012, 8848014, 8848015**

TO IDENTIFY MODEL AND ITEM NUMBER, SEE DATA TAG ON CONTROL PANEL

BILL OF MATERIAL

ITEM NBR ▶		8848011	8848012	8848014-8848015	
TYPE ▶		DOMESTIC	DOMESTIC	INTERNATIONAL	
VOLTAGE ▶		208V/60/1	236V/60/1	236V/50-60/1	
ASSEMBLY ▶		616B-1500	616B-1501	616B-1502	
REF	QUANTITY	PART NUMBER			DESCRIPTION
1	1	DR42-0162	DR42-0162	DR42-0162	THERMOSTAT 1P, W/ AUXILIARY
3	1	FM200-0065M	FM200-0065M	FM200-0065M	HI-LIMIT SWITCH
4	1	H-0001	H-0001A	H-0001A	ELEMENT
5	2	#PLT-0001	#PLT-0001	#PLT-0001	CLEAR NEON PILOT LIGHT
8	1	MK-0274	MK-0274	MK-0274	BULB BRKT CLAMP, UNIVERSAL
9	1	614A-0007	614A-0007	614A-0007	HEATER HEAD SKIRT
10	1	MK-0275 R02	MK-0275 R02	MK-0275 R02	BULB CLAMP TOP
11	1	616BT-0506	616BT-0506	616BT-0015 R10	HEATER HEAD BOTTOM ASSY
12	1	614A-0500 R05	614A-0500 R05	614A-0500 R05	HEATER HEAD CASE WLDT
13	1	618-0008A	618-0008A	DR42-0338	THERMOSTAT KNOB
15	1	MK-0282-1	MK-0282-1	MK-0282-1	ELEMENT TERMINAL INSULATOR
16	2	MK-0283-A R01	MK-0283-A R01	MK-0283-A R01	HIGH LIMIT MOUNTING BRACKET

FASTENERS

ITEM	QTY	PART NUMBER	DESCRIPTION
A	REF		10-24 X 3/8 RD HD SLOTTED MACH SCW
B	REF		#4 X 3/16 SHEET METAL SCW
C			
D	REF		10-24 HEX NUT
E	REF		#10 INT. TOOTH LOCK WASHER
F	REF		5/8-18 HEX NUT, JAM
G	REF		5/8 METAL WASHER
H	REF		5/8 FIBER WASHER
I	REF		8-32 X 1/4 RD HD SLOTTED MACH SCW
J	REF		6-32 X 1/4 RD HD SLOTTED MACH SCW
K	REF		6-32 X 1/4 PAN HD SLOTTED MACH SCW
L	REF		#6 X 3/8 SHEET METAL SCW
M	REF		10-24 X 5/16 RD HD SLOTTED MACH SCW

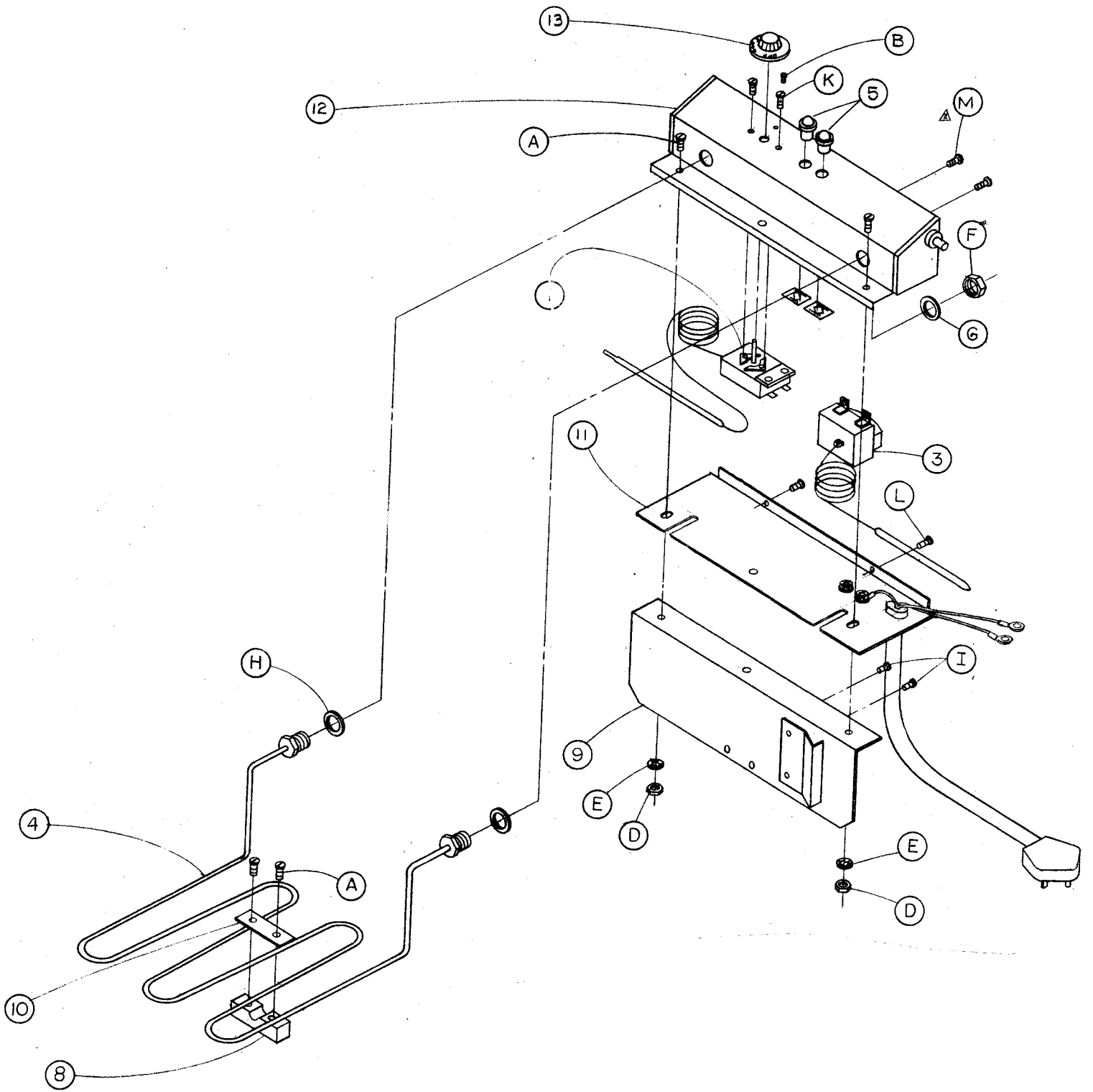

DIAGRAM: 616B-4001

USE THIS DIAGRAM FOR

**MODEL: 616B**

**ITEM NUMBER:**

**8848011, 8848012, 8848014, 8848015**

TO IDENTIFY MODEL AND ITEM NUMBER, SEE DATA TAG ON CONTROL PANEL

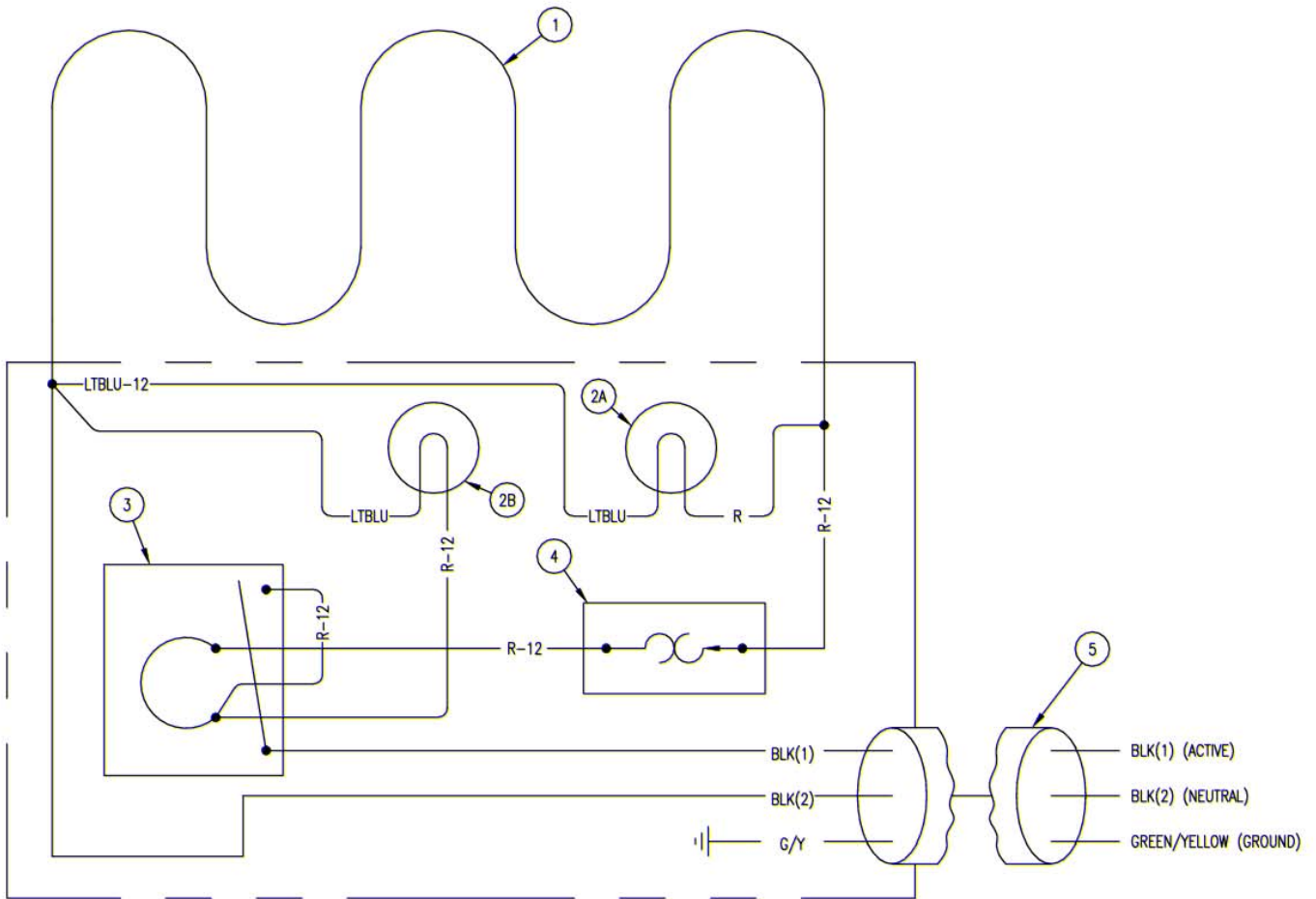

BILL OF MATERIAL

ITEM	QTY	PART NO.	SPARE	DESCRIPTION
1	1	H-1	1	HEATER ELEMENT, 4000W@208V #8848011
1	1	H-1A	1	HEATER ELEMENT, 4400W@240V #8848012, #8848014, #888015
2	2	PLT-0001	2	PILOT LIGHT, 250V, WHITE
3	1	DR42-0162	1	THERMOSTAT
4	1	FM200-0065	1	HI-TEMP LIMIT CONTROL
5	6 FT	995-0112	---	10-3 PVC POWER CORD UL/CSA/CE

DIAGRAM: 616-0512

USE THIS DIAGRAM FOR

**MODEL: 616B**

**ITEM NUMBER:**

**8848011, 8848012, 8848014, 8848015**

TO IDENTIFY MODEL AND ITEM NUMBER, SEE DATA TAG ON CONTROL PANEL

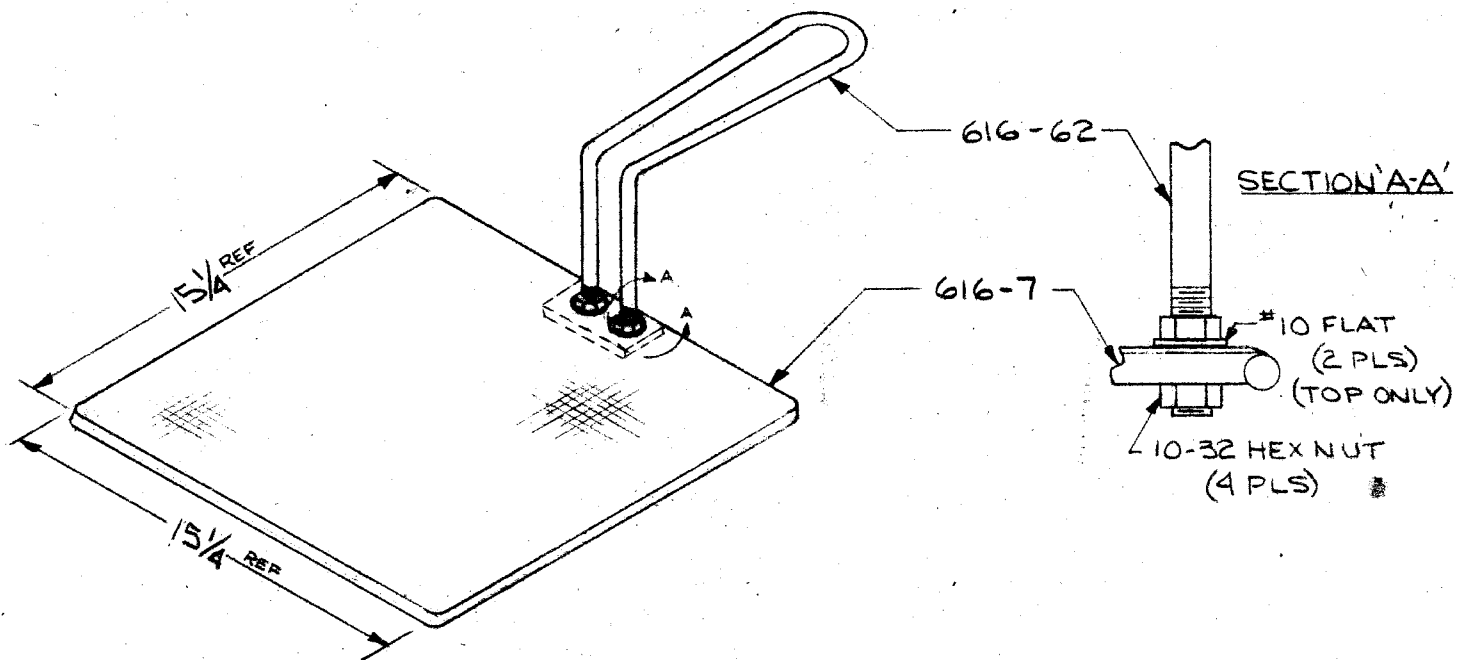

## Belshaw Adamatic Bakery Group

## Limited Warranty / Return Policy

Subject to the terms and limitations set forth in this limited warranty ("Limited Warranty"), Belshaw Adamatic Bakery Group (also referred to as "the Manufacturer") warrants to the original purchaser ("Purchaser") of Manufacturer's equipment and parts ("Products"), Belshaw Adamatic Bakery Group's manufacture and assembly of Products to be free from defects in workmanship and material which would result in product failure under normal use and service. Belshaw Adamatic Bakery Group's entire liability under this Limited Warranty is limited to either repairing or replacing at Manufacturer's factory or on Purchaser's premises, at Belshaw Adamatic Bakery Group's option, any Products purchased by Purchaser which shall be determined by the Manufacturer to be defective. If necessary to return Products to Manufacturer's factory, Products must be shipped by Purchaser with transportation charges prepaid by Purchaser.

Belshaw Adamatic Bakery Group reserves the right to make changes in design or add any improvement to its Products at any time without incurring any obligations to install the same on Products previously sold.

Possession, use or operation of Products sold hereunder for any other than their designed purpose, or use of Products which are in poor repair, modified, improperly operated, or neglected, is done at the Purchaser's risk. Belshaw Adamatic Bakery Group hereby disclaims any liability for these actions and shall not be liable for defects in or for any damages or loss to any property which is attributable to such actions.

**Under no circumstances shall Belshaw Adamatic Bakery Group be liable for any indirect, special, incidental, or consequential damages arising out of, or from the use of its Products by Purchaser, its assignees, employees, agents or customers.**

**THIS LIMITED WARRANTY SHALL BE PURCHASER'S SOLE AND EXCLUSIVE REMEDY WITH RESPECT TO DEFECTIVE PRODUCTS.**

### Warranty Period

This Limited Warranty covers Products manufactured by Belshaw Adamatic Bakery Group and sold by Belshaw Adamatic Bakery Group or its authorized distributor ("Distributor") or authorized dealer ("Dealer"), and this Limited Warranty shall extend for a period of one (1) year from date of shipment to Purchaser, and to the original Purchaser only.

### Limited Warranty

With respect to products not manufactured by Belshaw Adamatic Bakery Group, warranty coverage shall be limited to the warranty of the original manufacturer of the product, or the Belshaw Adamatic Bakery Group Limited Warranty, whichever is the lesser coverage period.

Replacement Products provided under the terms of this Limited Warranty are warranted for the remainder of the original warranty period applicable to the Product.

### Exclusions

This Limited Warranty excludes from its coverage and does not apply to: (a) solenoid and relay coils; (b) lamps; (c) "O" rings; (d) belts; and (e) impellers. This Limited Warranty also excludes the cost of labor for removing and replacing Products subject to a warranty claim, other than the labor incurred directly by the Manufacturer when, in Belshaw Adamatic Bakery Group's opinion, a repair of the Product by the Manufacturer is justified.

### Warranty Claims

In case of warranty claims relating to your Product, you must follow the instructions below.

### Report Claims to Your Authorized Distributor or Dealer or to Belshaw Adamatic Bakery Group

As soon as you discover a problem, contact the Distributor or Dealer from whom you purchased the Product or Belshaw Adamatic Bakery Group. Your Distributor or Dealer will notify Belshaw Adamatic Bakery Group for you. **Only Belshaw Adamatic Customer Service can approve or authorize warranty claims.**

You must state the following:

1. Your name, company name, and telephone number
2. The location, phone number, and contact name where the Product is located
3. The invoice number and date of purchase of the Product
4. The Model and Serial Number of the Product, as written on the data tag attached to the Product
5. A description of the problem and how it occurred

### Shipping Damage and Missing Items

**Damage to the Packaging or Crate.** On delivery, promptly check all packages thoroughly for any sign of damage. In cases of visible damage, **always note the damage on the Delivery Receipt.** Failure to note damage is taken by the Freight Carrier to mean that the package is in good condition at time of receipt, and can result in denial of a Freight Claim. Take photographs that clearly show the damage.

**Damage to Products.** If you find any damaged Product inside the shipment, photograph the damage both inside and outside of the package. Do not throw the packaging away. Photos of the package and contents are needed to show the condition of the Product at the time it was received.

**Missing Items.** As soon as you believe any items to be missing from a shipment, promptly report this to the Distributor or Dealer from whom the Product was purchased or to Belshaw Adamatic Bakery Group. If possible, photograph the entire contents of the delivery and email this to your Distributor or Dealer, or to Belshaw Adamatic Customer Service at [service@belshaw.com](mailto:service@belshaw.com).

### Returning Products to Belshaw Adamatic Bakery Group

Under the terms of the Limited Warranty, you may be asked to return to Belshaw Adamatic Bakery Group any Product that is the subject of a warranty claim. These Products must be clearly labeled with a Return Goods Authorization Number ("RGA Number") given to you by your Distributor or Dealer, or by Belshaw Adamatic Customer Service. Products received without an RGA Number will not be processed. All Products must be shipped freight prepaid by the Purchaser to Belshaw Adamatic Bakery Group at the address below.

### Contacting Belshaw Adamatic Bakery Group

At any time, you can contact Belshaw Adamatic Bakery Group customer service for assistance:

Belshaw Adamatic Bakery Group Customer Service  
814 44th St. NW, Suite 103,  
Auburn WA 98001, USA  
Phone: 800-578-2547 (USA/ Canada) or (+1)253-886-5340  
(Worldwide)  
Email: [service@belshaw.com](mailto:service@belshaw.com)  
Office Hours: Monday – Friday, 6am to 4pm, USA Pacific Time



*Belshaw*<sup>®</sup>

**The #1 Source for Donut and Bakery Equipment**

**[www.belshaw.com](http://www.belshaw.com)**

**BELSHAW ADAMATIC BAKERY GROUP  
814 44th Street NW, Suite 103  
Auburn, WA 98001 USA**

**1-800-578-2547 (USA/Canada)  
(+1) 253-886-5340 (Worldwide)**

**[service@belshaw.com](mailto:service@belshaw.com)**

an Ali Group Company



The Spirit of Excellence